



E10

1/8-SCALE 4WD READY-TO-RUN BUGGY

Operation Manual



The Spektrum trademark is used with permission of Bachmann Industries, Inc.

Losi, DSM and Nitrotane are trademarks or registered trademarks of Horizon Hobby, Inc. Not responsible for errors.

*Losi, a Division of Horizon Hobby, Inc.
Before operating this vehicle, please read all printed materials thoroughly.*

Notice

All instructions, warranties and other collateral documents are subject to change at the sole discretion of Horizon Hobby, Inc. For up-to-date product literature, visit <http://www.horizonhobby.com> and click on the support tab for this product.

Meaning of Special Language

The following terms are used throughout the product literature to indicate various levels of potential harm when operating this product:

NOTICE: Procedures, which if not properly followed, create a possibility of physical property damage AND a little or no possibility of injury.

CAUTION: Procedures, which if not properly followed, create the probability of physical property damage AND a possibility of serious injury.

WARNING: Procedures, which if not properly followed, create the probability of property damage, collateral damage, and serious injury OR create a high probability of superficial injury.



WARNING: Read the ENTIRE instruction manual to become familiar with the features of the product before operating. Failure to operate the product correctly can result in damage to the product, personal property and cause serious injury.

This is a sophisticated hobby product and NOT a toy. It must be operated with caution and common sense and requires some basic mechanical ability. Failure to operate this Product in a safe and responsible manner could result in injury or damage to the product or other property. This product is not intended for use by children without direct adult supervision. Do not attempt disassembly, use with incompatible components or augment product in any way without the approval of Horizon Hobby, Inc. This manual contains instructions for safety, operation and maintenance. It is essential to read and follow all the instructions and warnings in the manual, prior to assembly, setup or use, in order to operate correctly and avoid damage or serious injury.

Introduction

Thank you for choosing the 810. This is a highly developed RC model that features a sophisticated radio system and a nitro fuel-powered engine. It does require some mechanical experience and direct adult supervision. This guide contains the basic instructions and drawings needed to operate and maintain your new 810. Please take the time to read through these instructions completely before attempting to run your new model. In addition to the service information available in this operations guide, our online Support - Answer Center is available at www.losi.com for performance tips and troubleshooting questions. **Your hobby dealer cannot under any circumstances accept a model for return or exchange that has been run.** We are confident you will be satisfied with the high-speed performance in this durable and resilient vehicle.

Understanding that you are anxiously wanting to get your 810 ready for the open road, it will be to your long term benefit to make the effort and read through the entire manual. In the following pages you will find all the information you will need to set up as well as operate your new 810 to its full potential.

If you are an experienced RC hobbyist, or new to RC vehicles, it will benefit you to read all enclosed information.

From everyone at Losi we would like to thank you again for choosing the 810. Our goal is helping people have fun and enjoy using our products.

Register your Losi Product Online

Register your 810 now and be the first to find out about the latest options parts, product updates and more. Log on to www.LOSI.com and follow the product registration link to stay connected.

Caution:

Age Recommendation: 14 years or over. This is not a toy. This product is not intended for use by children without direct adult supervision.

This vehicle is capable of extreme speed and careful attention and care must be used when operating the 810.

When driving the 810 it is important that you take measures to avoid someone being hit by the vehicle. You may cause serious injury to another person, or to personal property should you make contact while running the 810. Before operating the 810 you must read and follow all of the following safety precautions and warnings.



Losi/Horizon Support

If you have any questions concerning setup or operation of your 810 RC vehicle please call Horizon Customer Support. Contact information can be found in the warranty section of this manual.

Getting Ready

Thoroughly read all the enclosed material, precautions and follow instructions to avoid damaging your new RC vehicle. If you choose to not follow these steps or instructions, it will be considered negligence.

If after review of this manual and prior to running your 810, you determine this RC vehicle is not what you want—DO NOT proceed and DO NOT run the 810. If the 810 has been run, your local hobby shop will not be able to process a return or accept it for exchange.

Safety Precautions:

THIS PRODUCT IS NOT A TOY! The 810 is a sophisticated, high-performance radio control model which needs to be operated with caution and common sense. Failure to operate this model in a safe and responsible manner could result in personal and/or property damage. It is your responsibility to see that the instructions and warnings are followed and precautions adhered to.

The 810 is not intended for use by children without direct adult supervision. Losi and Horizon Hobby shall not be liable for any loss or damages, whether direct, indirect, special, incidental, or consequential arising from the use, misuse, or abuse of this product or any product required to operate it.

*This is still only a model – do not expect it to do unrealistic stunts.

Warnings:

The 810 is powered by a special fuel containing flammable liquids and special care must be taken as noted below.

- Model fuel is dangerous if handled carelessly. Follow all directions and precautions on the fuel container. NEVER drink fuel - call a doctor immediately if ingested or splashed into your eyes.
- Keep fuel and all chemicals out of the reach of children.
- Always keep the fuel container closed and never use around an open flame or while smoking.
- The exhaust emits poisonous carbon monoxide fumes. Always run your model in a well ventilated area and never attempt to run it indoors.
- The top of the engine and the exhaust pipe are extremely hot during and after use. Use caution not to touch these parts, especially when refueling.
- The engine can be loud especially when run in a confined area. If you find the noise objectionable make sure to use ear protection.
- This model is controlled by a radio signal that is subject to interference from sources outside your control. Interference can cause temporary loss of control so it is advised to always keep a safety margin in all directions to avoid collisions.
- Always operate your model in an open area away from people and cars. The potential speed of this model can cause injury or damage.
- Never operate your 810 with low transmitter or receiver batteries – especially AA dry cells as control and power will be limited.
- Repeated or prolonged use of heavy braking will cause the brakes to overheat and fail! Always leave plenty of room for stopping.
- It will take as much room to stop as it does to accelerate to speed. Always run in an open area with plenty of braking room.

Batteries and Charging:

The 810 uses rechargeable batteries such as NiMH or LiPo. These batteries all have special requirements to preserve performance and last a long time. Read all instructions and precautions that are provided with the batteries intended to be used in the 810.

- Read all instructions provided by the manufacturer of the batteries.
- Responsible adult supervision is necessary while charging batteries.
- Always check to ensure the polarity of battery connection is correct.
- Never leave batteries unattended while charging.
- Never charge a battery while it is installed in the 810.
- Do not charge any battery that appears to have any damage.
- If there are exposed wires do not charge or use the battery until you have installed shrink-wrap or replaced the complete wire.

If charging NiMH batteries, select a charger to meet your requirements. Chargers can be of two primary types for their source of power: a 100-240V wall charger, or one which requires a 12V power supply. Follow the charger manufacturer's instructions and precautions during each use.

Supplied and Required Equipment

Supplied tools:

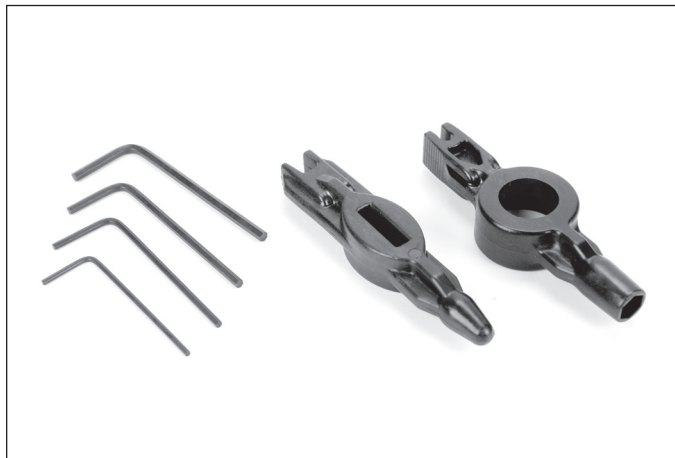

Four (4) Hex "L" Wrench Set

.050-inch, 1/16-inch, 5/64-inch, and 3/32-inch

Shock Bottom wrench

Turnbuckle/Shock Top wrench

Wheel Wrench (not pictured)

Tools You Will Find Handy

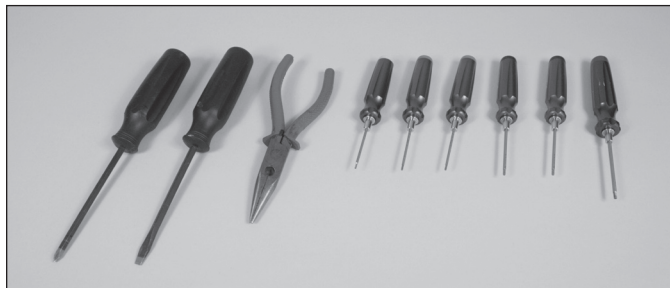

In addition to the tools included with the 810, you will find the following both useful and in some cases necessary.

- Small flat blade and Phillips screwdrivers
- Needle-nose pliers
- Quality .050-inch, 1/16-inch, 5/64-inch, 3/32-inch, 1.5mm and 2.5mm hex (Allen) drivers

Recommended Accessories

Fuel – Preferably Nitrotane 20% Sport (LOSF0020). Note: This fuel supports the engine warranty.

Fuel Bottle – The Losi 500cc fuel bottle (LOSB5201) is suggested.

Glow Igniter (LOSB5221)

Rechargeable Receiver battery (LOSB9951)

Flat blade screwdriver with infrared temperature gauge (LOSA99171)



The Losi 810 Overview

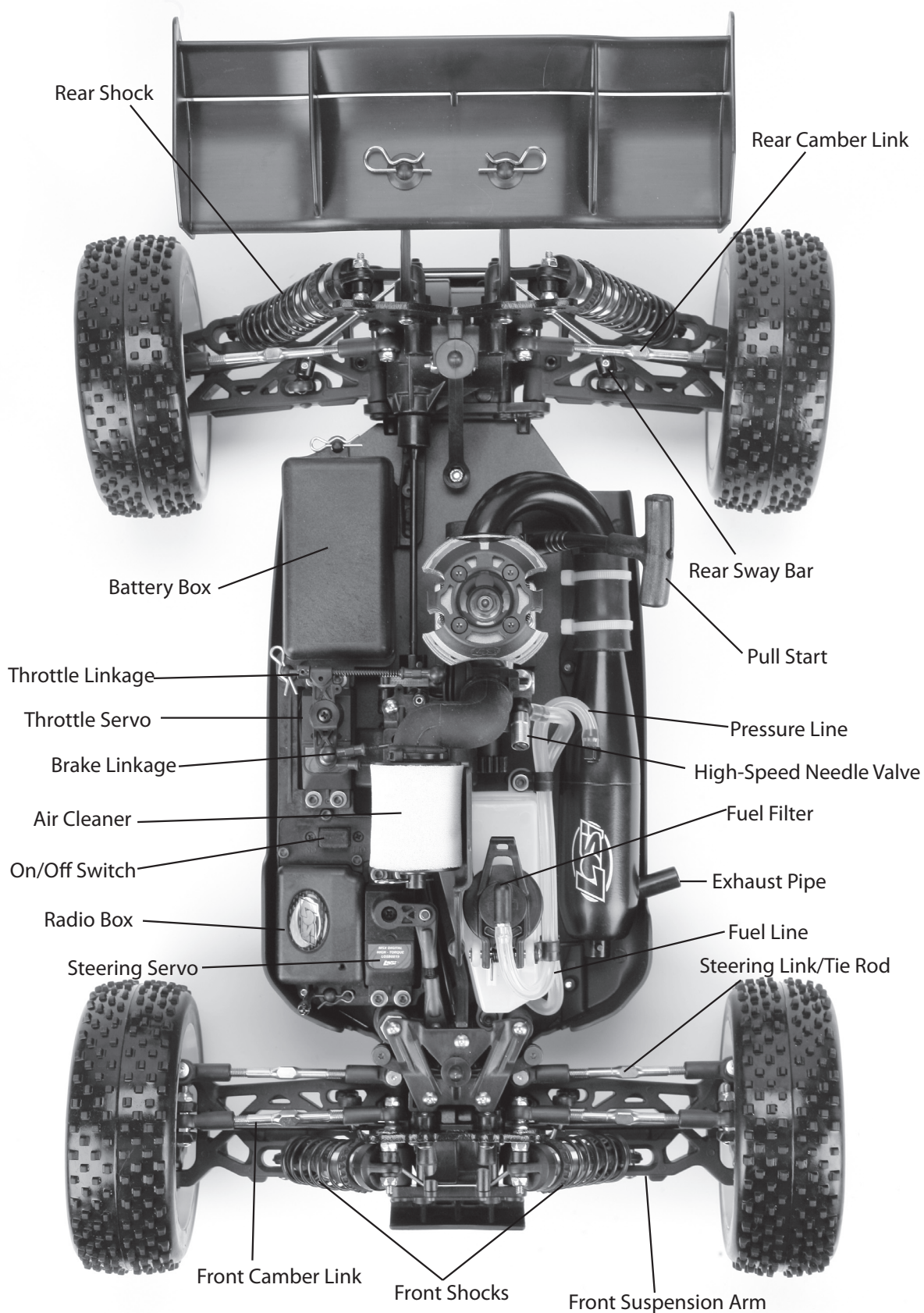

810 Radio System with Callouts

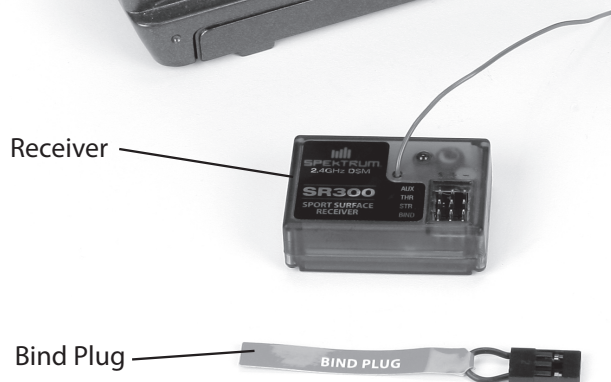
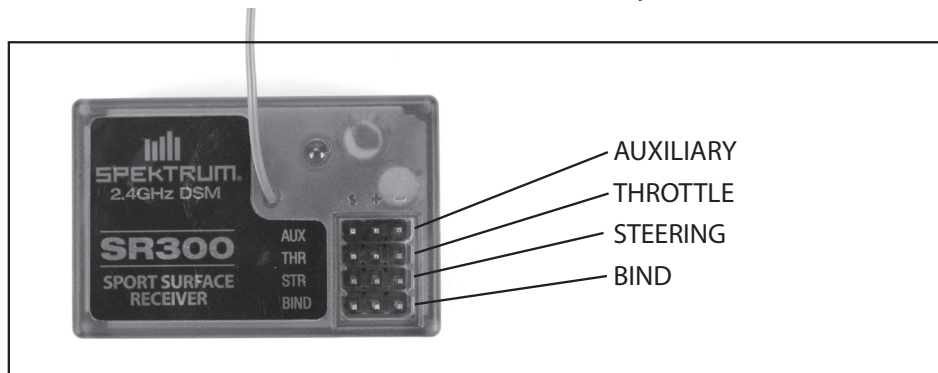

About the Radio

The Losi DSM[®] radio installed in the 810 is a state of the art system featuring the latest technology that requires no crystals. This system includes all the features you may find useful. Be sure to read through the Radio operation instructions on what and how to use these features. The following is a simple guide to items and functions commonly referred to.



1. Steering Wheel - Controls the trucks direction (left/right).
2. Throttle Trigger – Controls the speed and braking (pull for throttle and push forward for brakes).
3. Throttle Trim (TH.TRIM) - Allows you to set the idle/brake of the truck.
4. Steering Trim (ST.TRIM) – Adjusts the “hands off” direction of the truck.
5. Transmitter Antenna - Transmits signal to the receiver in the truck.
6. Servo Reversing Switches – Changes the direction of servo operation.
7. Power & Signal Indicators (LEDs)
Red (left) indicates signal strength.
Green (right) indicates battery power.
8. Power Switch - Turns your transmitter ON and OFF.
9. Steering Rate (ST.D/R) – Adjusts how much the wheels turn when steering wheel is turned right/left.
10. Endpoint Adjustment Pots – Allows you to adjust the maximum movement of the servos.
11. Bottom Cover – Removable for installing AA batteries.
12. Binding LED – Blinks when binding—solid indicates binding complete. (on reverse side)

Radio Operation

It is important that you familiarize yourself with the radio system, as this is your direct link to the model.

- Never run your model with low receiver or transmitter batteries.
- Always fold the antenna to the upright position before running your model.
- Never leave the power on or the batteries will not last long.
- Always turn the transmitter ON before turning the model ON.
- When finished running, always turn the model OFF before the transmitter.
- For best operation, it will be necessary to keep the “trims” adjusted for both the steering and throttle as noted on the following pages.

Steering Trim: The model should go straight without turning the steering wheel. If not, tap the trim lever found just above and to the right of the steering wheel in the direction needed for the model to go straight. Each tap of the trim button will be accompanied by an audible tone indicating a change has been made. It may take several taps to get the correct trim setting.

Throttle Trim: The model should idle without the tires rotating when the trigger is at its neutral position. If not, tap the trim lever found just above and to the left of the steering wheel to reposition the throttle servo and close the carburetor and apply more brakes. Note that additional braking force is applied when you push the trigger forward.

Binding the Radio System

Steps to Re-Bind

1. Ensure that the transmitter and vehicle are both turned off.
2. Using the supplied Bind plug (which looks like a standard receiver plug with a wire loop installed) insert the Bind plug into the receiver slot labeled "BIND". Looking down on the receiver this slot would be below the LED and is the farthest from the LED, or nearest to the corner of the receiver. Note: You do not need to remove any of the other plugs to re-bind.
3. With the Bind plug installed, turn on the vehicle. Notice a blinking Orange LED within the receiver.
4. Now you are ready to turn on the transmitter. You should notice on the back of the transmitter a similar blinking Orange LED under the translucent cover.
5. Both the receiver and transmitter blinking Orange LED will stop blinking and become solid, indicating they have "bound" themselves together.
6. Turn off both the vehicle and the transmitter then remove the Bind plug from the receiver. Failing to remove the Bind plug will cause the receiver to attempt to re-bind every time you turn on the vehicle and transmitter.
7. Turn on both the vehicle and transmitter to ensure operation. If the transmitter does not control the vehicle, please repeat steps 1–6. Should this not correct the problem, please call Horizon Service/Repair for further assistance.
8. The Bind process is complete. Your vehicle's radio system should be ready for use.

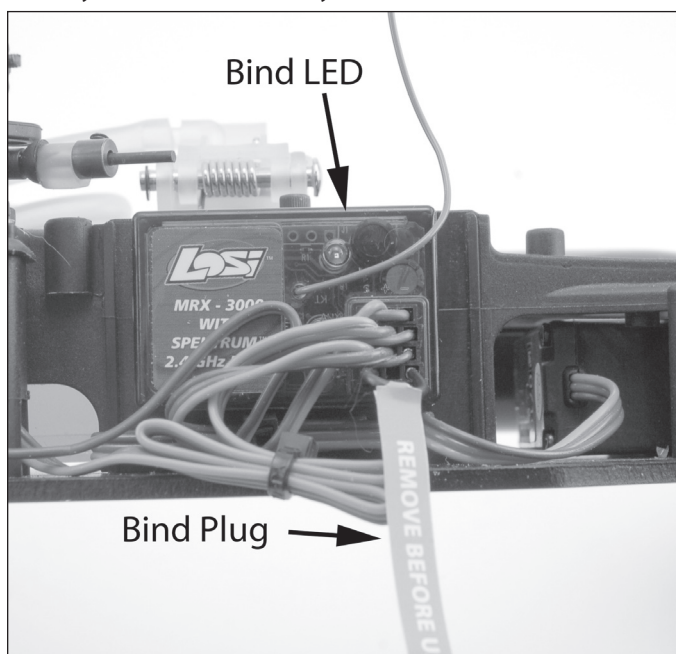

Using the EPA Adjustment

The Endpoint Adjustment (EPA) feature of the Losi DSM radio allows you to set the amount the servo travels when you turn the steering wheel or push/pull the throttle. This is especially helpful to prevent the servos from stalling with normal operation.

Steering: First set the steering trim so the truck goes straight without touching the steering wheel. Lift the front of the truck off of the ground and turn the steering wheel to the right. Use the included mini screwdriver to adjust the pot marked "right" back and forth stopping when the wheels can turn to the right no more. Repeat this procedure turning left using the pot marked "left".

Throttle: First set your Throttle/Brake trim. With the engine not running, remove the air cleaner. Pull full back on the throttle trigger and note the position of the carburetor barrel. Adjust the pot marked "throttle" back and forth so that the barrel just reaches wide open (going further will only hurt performance).

Brake: Release the trigger and push it forward. Turn the pot marked "brake" counterclockwise (away from the "+") as far as it will go. Now turn it clockwise (toward the "+") until it stops moving. This will give you maximum push brake.



Engine Break-In and Adjustments

The new Losi 3.4 engine in your 810 has been machined to tight tolerances and does not need an extended break-in. It is always a good idea to take it easy for the first few tanks of fuel to let all the gears and moving parts seat into one another. You will notice after the first hour of operation that the engine will pick up power. It is highly advised that you use Nitrotane 20% Sport fuel as the carburetor is factory set for this fuel and other fuels may require immediate needle valve adjustments. NEVER use model airplane fuel as it may cause damage to the engine and void any warranty. If you change fuels or run in dramatically different environments (hot/cold, high/low elevation, etc), you will probably have to adjust at least the high-speed needle to prevent overheating and maintain proper performance.

Tuning a Nitro Engine

Adjusting the carburetor is one of the most critical facets of running a nitro-powered RC vehicle. The fuel mixture is referred to as being "rich" when there is too much fuel and "lean" when there is not enough fuel for the amount of air entering the engine. The amount of fuel entering the engine is adjusted with high- and low-speed threaded needle valves. The low-speed needle is located in the front of the moving slide. The high-speed needle sticks straight up at the back of the carburetor. Both feature a slotted head that is used as a reference and receptacle for a flat blade screwdriver for adjustments. The mixture is made richer by turning the needle counterclockwise and leaner by turning clockwise. An overly "rich" mixture will yield sluggish acceleration and performance with thick smoke from the exhaust. A "lean" mixture can cause the engine to hesitate before accelerating or, in some cases, to lose power momentarily after the initial acceleration. A lean mixture also makes the engine run hotter than desired and does not provide enough lubrication for the internal engine components, causing premature wear and damage. It is always advisable to **run the engine slightly rich** and **never lean** to avoid overheating and possible damage.

Base Start-up Settings from the Factory

High-Speed Needle—2 $\frac{1}{2}$ turns out from bottom

Low-Speed Needle—2 $\frac{1}{2}$ turns out from bottom

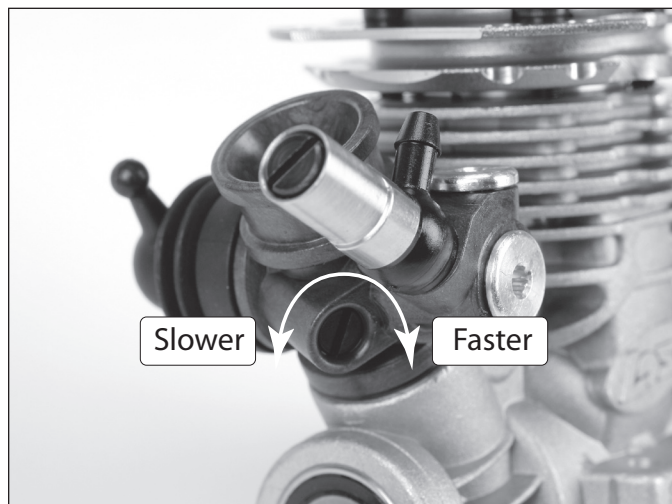

Engine Tuning

After the engine is broken in, you can tune it for optimum performance. When tuning, it is critical that you be cautious of overheating as severe damage and premature wear can occur. You want to make all carburetor adjustments in "one hour" increments.

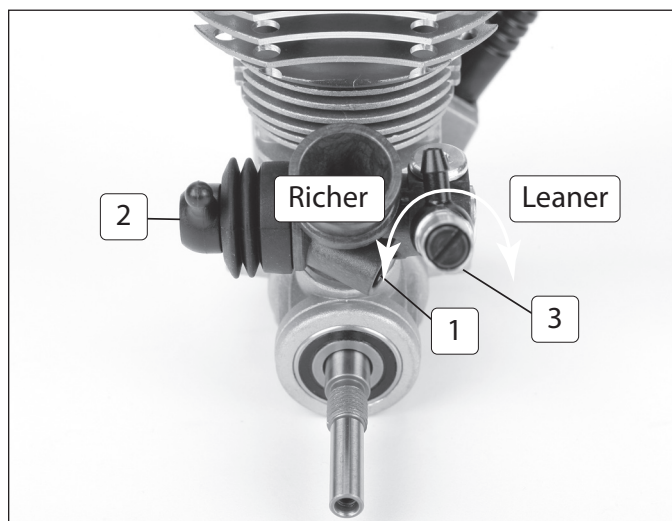

1= Idle Stop Screw

2=Low-Speed Needle

3=High-Speed Needle

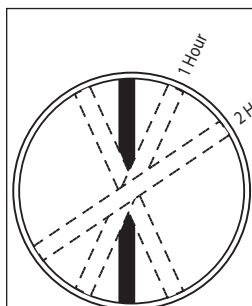
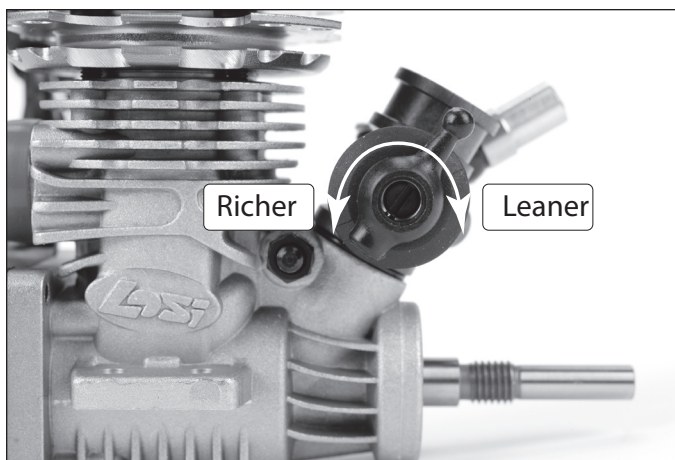

Carb Adjustments:

Make all carburetor adjustments in one-hour increments. Imagine the slot in the needle is the hour hand on a clock. Adjust it as though you were moving the hour hand from one hour to the next or previous one.

Low-Speed Adjustment

The low-speed adjustment affects the idle and slightly-off-idle performance. The optimum setting allows the motor to idle for at least 8–10 seconds. The model should then accelerate with a slight amount of sluggishness and a noticeable amount of smoke. The simplest way to check this is to make sure the engine has been warmed up and let the engine idle for 8–10 seconds. If the low-speed mixture is so far off that the engine won't stay running that long, turn the idle stop screw clockwise, increasing the idle speed. With the engine at idle, pinch and hold the fuel line near the carburetor, cutting off the flow of fuel, and listen closely to the engine rpm (speed). If the low-speed needle is set correctly, the engine speed will increase only slightly and then die. If the engine increases several hundred rpm before stopping, the low-speed needle is too rich. Lean the mixture by turning the needle clockwise one hour and trying again. If the engine speed does not increase but simply dies, the needle is too lean and needs to be richened up by turning the needle counterclockwise one hour before trying again. After you have optimized the low-speed setting, the engine will probably be idling faster. You will have to adjust the idle stop screw counterclockwise to slow the engine idle speed down. The engine should accelerate at a constant pace without hesitating.

High-Speed Adjustment

After initial acceleration, the engine should pull at a steady rate while maintaining a two-stroke whine and a noticeable trail of smoke. If the engine labors and is sluggish with heavy smoke, the mixture is too rich and needs to be leaned by turning the high-speed needle clockwise in one-hour increments until it runs smoothly. If the engine isn't smoking or starts to die after acceleration, it is too lean and you must richen the mixture by turning the needle counterclockwise. Don't be confused by the sound of the engine and the actual performance. A leaner mixture will produce an exhaust note with a higher pitch but this does not necessarily mean improved performance, as the engine is on the verge of overheating and may incur possible damage. Ideally you want to run the engine so that it is on the slightly rich side of optimum. This will give you the best combination of speed and engine life. **NOTICE:** The engine is too lean and overheating if it accelerates rapidly with a high-pitched scream then seems to labor, stops smoking, or loses speed. This can be caused by the terrain, atmospheric conditions, or drastic altitude changes. To avoid permanent engine damage, **immediately** richen the mixture by turning the high-speed needle counterclockwise at least "two hours" and be prepared for further adjustments before running any more. **Note:** The normal operating temperature as seen on your radio screen should be in the 190 to 220° F (88 to 105° C) range.

About Glow Plugs

The glow plug is like the ignition system in your automobile. The coiled element in the center of the plug glows red hot when connected to a 1.5-volt battery (located in the igniter). This is what ignites the fuel/air mixture when compressed in the cylinder. After the engine fires, the heat generated by the burning fuel keeps the element hot. Common reasons for the engine not starting are the 1.5-volt battery being weak, the glow plug being wet with fuel, or the element burned out. Use a spare glow plug to check the igniter. If the igniter makes the element glow, remove the plug from the engine to check it in the same manner. A wet glow plug means there is excess fuel in the engine. To eliminate this, put a rag over the head and turn the engine over a few seconds using the pull start. Reinstall the glow plug, making sure you have the brass gasket on it. The engine should now start.

Testing the Temperature



The ideal operating temperature for an engine will vary with the air temperature but in general it should be in the 190° to 230°F (88 to 110° C) range. Since the 810 has a head protector you will have to rely on your ears or preferably a remote temperature gauge like the Losi Temp-Tuner™ (LOSA99171) which incorporates an infrared temp sensor/gauge and a handy carburetor tuning screwdriver. If the engine is overheating turn the high-speed needle out (counter clockwise) at least two hours. If the engine is running rich (below 190° F) turn the high-speed needle in (clockwise) one hour at a time until it is running within the normal range.

Driving the 810

Always follow these precautions when running your 810.

The electronics in this model are not waterproof and you must avoid running it in or through standing water, wet grass, mud or snow.

Do not run the 810 at dusk or in the dark when visibility is limited.

Do not attempt to run this model if it will be out of sight for any amount of time.

Do not run this model near a crowd of people.

Always check for proper radio function and battery condition before operating.

Check to make sure that the tires are securely glued to the rims.

Check the model thoroughly for loose nuts, bolts and screws before and after running.

Make sure you use proper dirt tires if running off-road.

Never run the model with old or discharged batteries – especially dry cells in the model.

If the model gets stuck do not pull the throttle as it may result in damage to the engine or clutch.

Leave plenty of room to stop the model. It will take as much room to stop as it did to accelerate.

Avoid repeated or prolonged heavy braking as this will cause the brakes to overheat and fail.

Maintenance

In addition to the service needs pointed out in this guide, you should try to maintain your new 810 for proper performance and to prevent wear. If dirt gets in the moving parts it can seriously hinder the performance of the model. Use compressed air, a soft paintbrush and/or a toothbrush to remove dirt and dust. Avoid using solvents, if possible, as this can actually wash the dirt into bearings and areas not accessible without disassembly, causing additional wear. We suggest you follow these basic guidelines.

- Remove as much freestanding dirt and dust as noted above.
- Never leave fuel in the tank for more than a couple of hours.
- When done running for the day or longer, let the engine run out of fuel. Remove the air cleaner and spray a little water-displacing lubricant, or quality after-run engine oil into the carburetor and spin the engine over a few seconds.
- If needed, clean and re-oil the air cleaner before installing it back on the model.
- Inspect the chassis for worn, broken or binding parts and repair as necessary.

Storage

When you are done running the 810 for the day:

- Blow it off with compressed air and/or use a soft bristle paintbrush to remove dust and dirt from the chassis.
- Use your fuel bottle to remove any remaining fuel out of the fuel tank.
- If the model is going to be stored for an extended time period. Unplug the receiver battery and remove the batteries from the transmitter.

Tuning, Adjusting and Maintaining the 810

Periodically examine your 810 for the following:

- Keep your vehicle clean using a brush to remove dirt and dust.
- Look for cracks in the suspension arms and other molded parts.
- Check that the tires are still glued to the wheels.
- Check that all the wheel bearings are clean and lubricated.
- Using your tools, attempt to tighten all the screws and nuts.
- Verify that the Camber Links and Steering linkage are not bent.
- Check that the Toe and Camber settings are as desired and equal.
- Check the Drivetrain:
 - Check the Spur gear for wear.
 - Check the Pinion gear.
- Take the shocks off the vehicle and check, especially if they appear to be leaking as it is time to rebuild them.
- Look over all the wiring and connections for bare wire or any place which could lead to a short circuit.
- Turn on the radio and if the Green LED is off or dim replace the 4 AA batteries in the transmitter.
- Turn on both the transmitter and the model and steer the vehicle. If the steering is very slow, replace the batteries inside the vehicle.

After you become familiar with driving your 810, you may need to reset or make adjustments for better driving performance.

Just as in a real car, alignment is an important factor in your vehicle's handling. When you are ready to make adjustments it is a good idea to have a flat work space to place your vehicle on. This will enable you to easily and more quickly make both Toe-in and Chamber adjustments. These adjustments should be set with the vehicle sitting at its normal ride height.

Starting Settings

Carburetor:

- High-Speed: 2½ Turns Out
Low-Speed: 2½ Turns Out

Tuning the Front End of the 810

Shock Location: The 810 has three mounting locations on the front shock tower. The position can be easily adjusted by simply moving the top of the shock to another hole. The standard location works best on most surfaces. Moving the top of the shock inward a hole will slow steering response and make the 810 smoother in bumps. The standard position on the arm is middle, which offers the best balance. Running the inside shock location will give the 810 more steering into the turn and less steering on corner exit. Running the shock location outside on the front arm will give you less overall steering into the turn and keep the front end flatter through the turn, making the 810 smoother and easier to drive. This can be used on high-traction surfaces. Keep in mind as you move the shocks in on the arm you may want to adjust your droop using the droop setscrews to limit travel.

All of the Camber and Steering linkages feature left and right-hand threads at either end like a turnbuckle to make adjustments easy. The side with right-hand threads has a small groove machined into it. Use the plastic turnbuckle wrench supplied with the 810 to adjust these. Using the right-hand threaded side as your reference: if you turn the link to the right (clockwise) you will make it shorter. If you turn it to the left (counterclockwise) you will make it longer. If you will be making a lot of adjustments you should consider using the LOSA99165 Aluminum Turnbuckle Wrench.

Static Camber: This refers to the angle of the wheels/tires relative to the surface (viewed from either the front or back). Negative camber means that the top of the tire leans in toward the chassis. Positive camber means the top of the tire leans out, away from the chassis. Camber can be precisely measured with after-market camber gauges, sold at a local hobby shop. It can be measured (roughly) using any square (to the ground) object by checking the gap between the square edge and the top of the tire. Testing has shown that 1 degree of negative camber is best for most track conditions. Increasing negative camber (in the range of 1-2 degrees) will generally increase steering. Decreasing negative camber (in the range of 0-1 degree) will generally decrease steering and the 810 will feel easier to drive as a result. This is, most often, a very critical adjustment in tuning your 810 that can be made quickly and easily.



Inboard Camber Location: The 810 has two different inner locations with vertical adjustment for the front camber tie rod. In general, the lower or further out the inside position is, relative to the outside, the more camber gain (total camber change through the total throw of the suspension) is present. This is an adjustment that is difficult to make a generic statement as it can have slightly different results in various conditions. The following is a summary of how this adjustment will usually impact the handling of the 810. A longer front camber link will usually make the 810 feel stiffer. This will help keep the 810 flatter with less roll, but can make the 810 handle worse in bumpy conditions, it also will make the 810 easier to drive. A shorter front camber link will result in more front end roll, which will provide more steering on tighter turns with the loss of some stability. You will also lose some high-speed steering but might gain some more steering response. Too short of a front link may make the 810 feel "twitchy" or "wandery" meaning that it may be difficult to drive straight at high speed.

Inboard Camber Vertical Adjustment: In general the upper hole will make the 810 more stable and keep the front end flatter. This works well on higher traction surfaces. The lower location will make the steering more aggressive which works well on lower traction surfaces. This can be good in some conditions but can also make the 810 difficult to drive in others.

Toe-In/Out: This is the parallel relationship of the front tires to one another. Toe-in/out adjustments are made by changing the overall length of the steering tie rods. Toe-in (the front of the tires point inward, to a point in front of the front axle) will make the 810 react a little slower, but have more steering from the middle of the turn, out. The opposite is true with toe-out (the front of the tires point outward, coming to a point behind the front axle), the 810 will turn into the corner better but with a decrease in steering from the middle of the turn, out. Toe-in will help the 810 to track better on long straight high-speed runs, where toe-out has a tendency to make the 810 wander. We recommend to run between 0-degree of toe-in/out to 1 degree of toe-in.

Tuning the Rear End of the 810

Shock Location: Moving the shocks out on the arm will result in less forward traction and let the 810 make more of an arc through the exit of the turn. In general, when changing shock locations on the arm, it will be necessary to go down one spring rate when moving out on the arm.

Static Camber: Having the same definition as for the front end and measured in the same fashion, rear camber can also be a critical tuning feature. Testing has shown that running a small amount of negative camber (.5-1 degree) is best. Increasing negative rear camber (in the range of 1.5-3 degrees) will increase stability and traction in corners, but decrease high-speed stability. Decreasing rear camber (in the range of 0-1.5 degrees) will decrease stability and traction in corners, but will increase high-speed stability.

Inboard Camber Location: The 810 has two inner camber link locations. These locations work in the same fashion and have the same effect as noted for the front. You will find that you will get more noticeable changes with the outer locations in the hub. In general the upper hole will make the 810 more stable and keep the front end flatter. This works well on higher traction surfaces. The lower location will make the steering more aggressive which works well on lower traction surfaces. This can be good in some conditions but can also make the 810 difficult to drive in others.

Outboard Camber Location: Running the camber link in the inside position on the hub will generate more rotation entering a turn, but decrease steering on exit. Running the camber link in the furthest outer position on the hub will generate more stability entering a turn and increase steering on exit.

Toe-In: Having the same definition as for the front end, the toe-in can be adjusted on the 810 with the rear hubs. The stock toe-in is 3 degrees of inboard per side and 0 degrees in the hub. Increasing rear toe-in will increase forward traction and initial steering, but reduce straightaway speed. Decreasing rear toe-in will decrease forward traction and "free-up" the 810. Less toe-in can be used to gain top speed.

Ride Height: This is the height of the chassis in relation to the surface. It is an adjustment that affects the way your 810 jumps, turns and goes through bumps. To check the ride height, drop one end (front or rear) of the 810 from about a 5 to 6-inch height onto a flat surface. Once the 810 settles into a position, check the height of that end of the 810 in relationship to the surface. To raise the ride height, lower the shock adjuster nuts on the shock evenly on the end (front or rear) of the 810 that you are working on. To lower the ride height, raise the shock adjuster nuts. Both left and right nuts should be adjusted evenly. Check the setup sheet included and for additional setup information visit www.losi.com.

Use the same technique to adjust the rear ride height. Again, refer to the included setup sheet. Every driver likes a little different feel so you should try small ride height adjustment to obtain the feel you like. This should be the last adjustments you make after everything else is dialed in. Note: Do not use ride height adjustments as a substitute for a spring rate change. If your 810 needs a softer or firmer spring, change the spring. Do not think that simply moving the shock nuts will change the spring stiffness as it will NOT!

Wheels and Tires

The tires come pre-mounted with the vehicle and should be checked to make certain they stay glued to the wheels. The wheel spinning speeds this vehicle is capable of tend to pull the rubber tire away from the rim. When a tire or tires come loose from the rim, you will notice the vehicle is hard to control.

Tip the vehicle on its side and using both hands to hold one wheel at a time, use your thumb to press the tire away from the rim. If you see a tire pull away from the rim use Losi Tire Glue (LOSA7880 thick or LOSA7881 thin) to reglue. It only takes a small drop of glue generally. Be careful—this is CA-type glue and you do not want to glue your fingers to the wheel and tire.

Use safety goggles when gluing tires.

Check the mounting of the tire periodically to ensure proper performance and handling.

Troubleshooting your 810

Many questions are the result of simple user errors or minor adjustments which are easily addressed. If after reading below you cannot resolve your problem, then please contact the appropriate product support office.

Radio system does not work properly:

If the power on your transmitter is not turning on, first check to make sure the batteries are installed correctly. If the battery power is too low, replace the four AA dry cells. When you turn on the vehicle, if the servos fail to move, replace the four AA dry cells in the vehicle. If the radio still does not function you may need to rebind the radio. Refer to the step-by-step instructions elsewhere in this manual to bind your system.

Short radio range:

If the radio range appears short, make sure the batteries are all fully charged and/or are in good condition.

Steering or Throttle servo does not work:

Check all wires, radio system, battery connectors, and the battery pack. Replace the servo if it remains unresponsive.

Engine will not start:

1. Remove and check the glow plug.
2. Make sure there is fuel in the tank.
3. Check the fuel line for holes or cuts.
4. Note that the fuel is getting up to the carburetor. If not wait for the exhaust pipe to cool, put your finger over the exhaust tip, and turn the engine over watching for the fuel to go up the fuel line until it gets to the carburetor. Do not continue to turn the engine over with your finger over the exhaust tip after the fuel has reached the carburetor.
5. If the fuel has been left open or is over 6 months old, try replacing the fuel including that in the fuel line.



Engine is hard to turn over:

1. The engine may be flooded. Remove the glow plug, turn the model upside down over a rag and turn the engine over using the pull start. Raw fuel should spray out of the glow plug hole. Replace the glow plug making sure you replace the small copper gasket that goes on it.
2. If the engine will not turn over it is probably still new and stuck at top dead center. Use a screwdriver to rotate the flywheel on the engine counterclockwise until it moves freely, turn the model off then on again and retry. It may take several such tries to get it to start. After the engine has been run 30 to 45 minutes, you will find this will not occur.

Engine tries to start but will not run:

1. Engine may be loaded up with excess fuel inside. Pull the trigger 1/4-inch and count to 5 before trying to start. If starting improves repeat until the engine runs and idles.
2. Engine may be overheated. Let cool, open high-speed needle 2 hours and retry.
3. If the fuel has been left open or is over 6 months old try replacing the fuel including that in the fuel line.
4. If the engine refuses to start, read the "Engine Tuning" section for more help.

Servicing Your Shocks

From time to time you should check your shocks for adequate fluid. If the fluid is low, or it is getting dirty, you should change the fluid in the shocks. You may also want to change the shock fluid and or the pistons to better address the conditions you are running on. Regardless of what the reason you will want to follow these simple steps to service, refill, and bleed your 810 shocks. Note that if you are cleaning or changing the fluid you will find the LOSA99217 Nitrotec™ Spray Cleaner to be the quickest and easiest way to remove oil fluid and dirt safely.

1. If you are changing the pistons, clean the threads on the end of the shock shaft and apply thread locker (LOSA99202) to the threads.
2. Install the small shock piston washer and shock piston using the 4-40 mini lock nut on the shock shaft to secure them.
3. Put a drop of shock fluid on the shaft before replacing it in the shock body.
4. If you are changing the shock end use the shock tool provided with the 810 to hold the shaft. You will see that this plastic tool has serrations on both sides that allow you to hold it with a pair of pliers and not scratch up the micro finished surface. This method works very well to protect the shock shafts from damage.
5. After installing, make sure the shaft is fully extended when filling the shock.
6. Fill the shock body with 30-35-weight shock fluid until it is to the top of the Body.
7. Work the shock shaft up and down a few times. This will release the air bubbles trapped beneath the piston.
8. Place the filled shock, in the upright position, off to the side for a few minutes until the air bubbles escape from the fluid.
9. Once all the air bubbles are out of the fluid, gently place the shock bladder onto the top of the shock. Some fluid will "bleed" from around the bladder.
10. Screw the shock cap onto the body until a little resistance is felt.
11. Slowly push the shock shaft up. This will allow excess fluid to bleed out.
12. Tighten the cap all the way down using the shock tools included in your kit.
13. Move the shock shaft up and down. The shaft should be easy to push up into the body of the shock.
14. If increased pressure is felt towards the top, there is too much oil in the shock. Loosen the shock cap and bleed the shock as done in steps 11 & 12.
15. Make sure each pair (front/rear) of shocks has the same rebound and compression. This is checked by holding one shock in each hand horizontally and pushing them together by the shock end. Watch carefully to ensure that both compress evenly. Now release both shocks and again; watch carefully as they should rebound the same.

Warranty and Repair Policy

Warranty Period

Exclusive Warranty- Horizon Hobby, Inc., (Horizon) warrants that the Products purchased (the "Product") will be free from defects in materials and workmanship at the date of purchase by the Purchaser.

Limited Warranty

Horizon reserves the right to change or modify this warranty without notice and disclaims all other warranties, express or implied.

(a) This warranty is limited to the original Purchaser ("Purchaser") and is not transferable. REPAIR OR REPLACEMENT AS PROVIDED UNDER THIS WARRANTY IS THE EXCLUSIVE REMEDY OF THE PURCHASER. This warranty covers only those Products purchased from an authorized Horizon dealer. Third party transactions are not covered by this warranty. Proof of purchase is required for all warranty claims.

(b) Limitations- HORIZON MAKES NO WARRANTY OR REPRESENTATION, EXPRESS OR IMPLIED, ABOUT NON-INFRINGEMENT, MERCHANTABILITY OR FITNESS FOR A PARTICULAR PURPOSE OF THE PRODUCT. THE PURCHASER ACKNOWLEDGES THAT THEY ALONE HAVE DETERMINED THAT THE PRODUCT WILL SUITABLY MEET THE REQUIREMENTS OF THE PURCHASER'S INTENDED USE.

(c) Purchaser Remedy- Horizon's sole obligation hereunder shall be that Horizon will, at its option, (i) repair or (ii) replace, any Product determined by Horizon to be defective. In the event of a defect, these are the Purchaser's exclusive remedies. Horizon reserves the right to inspect any and all equipment involved in a warranty claim. Repair or replacement decisions are at the sole discretion of Horizon. This warranty does not cover cosmetic damage or damage due to acts of God, accident, misuse, abuse, negligence, commercial use, or modification of or to any part of the Product. This warranty does not cover damage due to improper installation, operation, maintenance, or attempted repair by anyone other than Horizon. Return of any Product by Purchaser must be approved in writing by Horizon before shipment.

Damage Limits

HORIZON SHALL NOT BE LIABLE FOR SPECIAL, INDIRECT OR CONSEQUENTIAL DAMAGES, LOSS OF PROFITS OR PRODUCTION OR COMMERCIAL LOSS IN ANY WAY CONNECTED WITH THE PRODUCT, WHETHER SUCH CLAIM IS BASED IN CONTRACT, WARRANTY, NEGLIGENCE, OR STRICT LIABILITY. Further, in no event shall the liability of Horizon exceed the individual price of the Product on which liability is asserted. As Horizon has no control over use, setup, final assembly, modification or misuse, no liability shall be assumed nor accepted for any resulting damage or injury. By the act of use, setup or assembly, the user accepts all resulting liability.

If you as the Purchaser or user are not prepared to accept the liability associated with the use of this Product, you are advised to return this Product immediately in new and unused condition to the place of purchase.

Law: These Terms are governed by Illinois law (without regard to conflict of law principals).

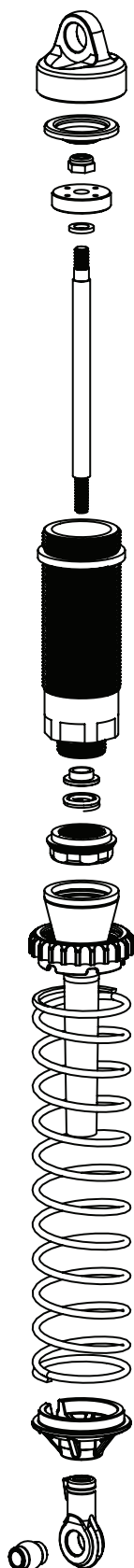



Warranty Services

Questions, Assistance, and Repairs

Your local hobby store and/or place of purchase cannot provide warranty support or repair. Once assembly, setup or use of the Product has been started, you must contact Horizon directly. This will enable Horizon to better answer your questions and service you in the event that you may need any assistance. For questions or assistance, please direct your email to productsupport@horizonhobby.com, or call 877.504.0233 toll free to speak to a Product Support representative. You may also find information on our website at www.horizonhobby.com.

Inspection or Repairs

If this Product needs to be inspected or repaired, please use the Horizon Online Repair Request submission process found on our website or call Horizon to obtain a Return Merchandise Authorization (RMA) number. Pack the Product securely using a shipping carton. Please note that original boxes may be included, but are not designed to withstand the rigors of shipping without additional protection. Ship via a carrier that provides tracking and insurance for lost or damaged parcels, as Horizon is not responsible for merchandise until it arrives and is accepted at our facility. An Online Repair Request is available at www.horizonhobby.com <http://www.horizonhobby.com> under the Repairs tab. If you do not have internet access, please contact Horizon Product Support to obtain a RMA number along with instructions for submitting your product for repair. When calling Horizon, you will be asked to provide your complete name, street address, email address and phone number where you can be reached during business hours. When sending product into Horizon, please include your RMA number, a list of the included items, and a brief summary of the problem. A copy of your original sales receipt must be included for warranty consideration. Be sure your name, address, and RMA number are clearly written on the outside of the shipping carton.

NOTICE: Do not ship batteries to Horizon. If you have any issue with a battery, please contact the appropriate Horizon Product Support office.

Warranty Inspection and Repairs

To receive warranty service, you must include your original sales receipt verifying the proof-of-purchase date. Provided warranty conditions have been met, your Product will be repaired or replaced free of charge. Repair or replacement decisions are at the sole discretion of Horizon.

Non-Warranty Repairs

Should your repair not be covered by warranty the repair will be completed and payment will be required without notification or estimate of the expense unless the expense exceeds 50% of the retail purchase cost. By submitting the item for repair you are agreeing to payment of the repair without notification. Repair estimates are available upon request. You must include this request with your repair. Non-warranty repair estimates will be billed a minimum of ½ hour of labor. In addition you will be billed for return freight. Horizon accepts money orders and cashiers checks, as well as Visa, MasterCard, American Express, and Discover cards. By submitting any item to Horizon for inspection or repair, you are agreeing to Horizon's Terms and Conditions found on our website under the Repairs tab.

United States

(Electronics and engines)

Horizon Service Center
4105 Fieldstone Rd
Champaign, Illinois
61822 USA
productsupport@horizonhobby.com
877-504-0233

(All other products)

Horizon Product Support
4105 Fieldstone Rd
Champaign, Illinois
61822 USA
productsupport@horizonhobby.com
877-504-0233

United Kingdom

Horizon Hobby Limited
Units 1-4 Ployters Rd
Staple Tye
Harlow, Essex
CM18 7NS
United Kingdom
sales@horizonhobby.co.uk
+44 (0) 1279 641 097

Germany

Horizon Technischer Service
Hamburger Str. 10
25335 Elmshorn
Germany
service@horizonhobby.de
+49 4121 46199 66

France

Horizon Hobby SAS
14 Rue Gustave Eiffel
Zone d'Activité du Réveil Matin
91230 Montgeron
+33 (0) 1 60 47 44 70

FCC Information

This device complies with part 15 of the FCC rules. Operation is subject to the following two conditions: (1) This device may not cause harmful interference, and (2) this device must accept any interference received, including interference that may cause undesired operation.

Caution: Changes or modifications not expressly approved by the party responsible for compliance could void the user's authority to operate the equipment.

This product contains a radio transmitter with wireless technology which has been tested and found to be compliant with the applicable regulations governing a radio transmitter in the 2.400 GHz to 2.4835 GHz frequency range.

Antenna Separation Distance

When operating your transmitter, please be sure to maintain a separation distance of at least 5 cm between your body (excluding fingers, hands, wrists, ankles and feet) and the antenna to meet RF exposure safety requirements as determined by FCC regulations.

The illustrations below show the approximate 5 cm RF exposure area and typical hand placement when operating your transmitter.

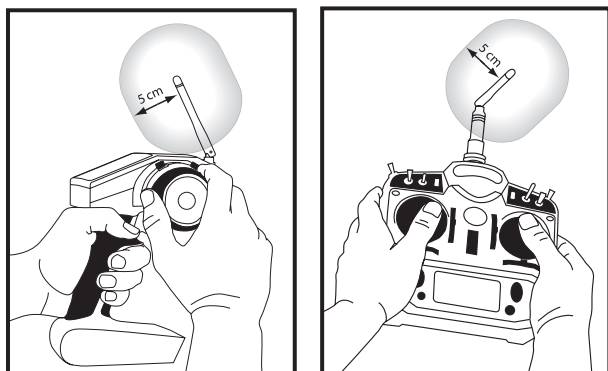

Compliance Information for the European Union



AT	BG	CZ	CY	DE
DK	ES	FI	GR	HU
IE	IT	LT	LU	LV
MT	NL	PL	PT	RO
SE	SI		SK	UK

CE Declaration of Conformity

(in accordance with ISO/IEC 17050-1)

No. HH20100823

Product(s): LOS 1/8 810 Buggy RTR
Item Number(s): LOSB0021

Equipment class: 2

The object of declaration described above is in conformity with the requirements of the specifications listed below, following the provisions of the European R&TTE directive 1999/5/EC:

EN 300-328	Technical requirements for Radio equipment.
EN 301 489	General EMC requirements
EN 60950	Safety

Signed for and on behalf of:

Horizon Hobby, Inc.
Champaign, IL USA
Aug 23, 2010

Steven A. Hall

Vice President
International Operations and Risk Management
Horizon Hobby, Inc.

Instructions for Disposal of WEEE by Users in the European Union

This product must not be disposed of with other waste. Instead, it is the user's responsibility to dispose of their waste equipment by handing it over to a designated collection point for the recycling of waste electrical and electronic equipment. The separate collection and recycling of your waste equipment at the time of disposal will help to conserve natural resources and ensure that it is recycled in a manner that protects human health and the environment. For more information about where you can drop off your waste equipment for recycling, please contact your local city office, your household waste disposal service or where you purchased the product.

Losi 3.4 Rear Exhaust Engine

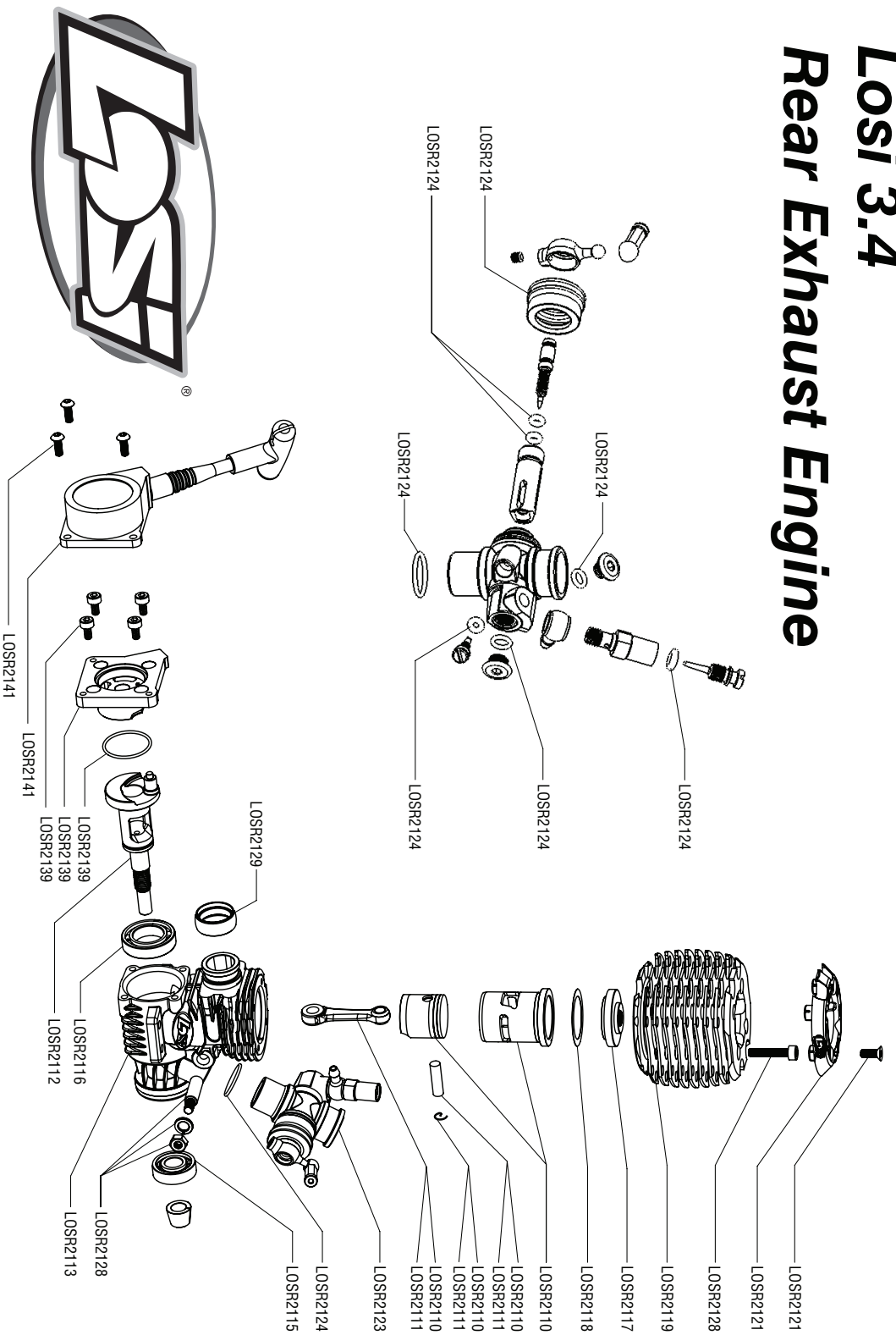

Engine Components

LOSR2110	3.4 Pist/Sleeve/Rod/Wrist Pin.....	\$89.99
LOSR2111	3.4 Connecting Rod with Clips.....	\$29.99
LOSR2112	3.4 Crankshaft.....	\$56.99
LOSR2113	3.4 Crankcase.....	\$39.99
LOSR2139	Backplate, Pull Start: 3.4.....	\$**.**
LOSR2115	3.4 Front Bearing.....	\$14.99
LOSR2116	3.4 Rear Bearing.....	\$18.99
LOSR2117	3.4 Combustion Chamber.....	\$8.99

LOSR2118	3.4 Head Gasket Set (1 & 2mm).....	\$3.49
LOSR2119	3.4 Heat Sink - Orange.....	\$44.99
LOSR2121	3.4 Head Protector & Screws.....	\$4.99
LOSR2123	3.4 Carburetor Complete.....	\$44.99
LOSR2124	3.4 Carb O-Rings & Bellows.....	\$4.99
LOSR2128	3.4 Screw/Hardware Set (10).....	\$7.99
LOSR2129	3.4 Exhaust Seals (2).....	\$4.99
LOSR2141	Pull Start Only: 3.4, 810.....	\$24.99

SETUP SHEET

Name: 810		Date: 7/19/10	Event:
City:		Track:	
State:			
Track <input type="checkbox"/> Indoor <input type="checkbox"/> Tight <input checked="" type="checkbox"/> Smooth <input checked="" type="checkbox"/> Hard Packed <input type="checkbox"/> Blue Groove <input type="checkbox"/> Wet <input type="checkbox"/> Low Bite <input type="checkbox"/> High Bite Conditions <input checked="" type="checkbox"/> Outdoor <input checked="" type="checkbox"/> Open <input type="checkbox"/> Rough <input type="checkbox"/> Loose/Loamy <input type="checkbox"/> Dry <input type="checkbox"/> Dusty <input checked="" type="checkbox"/> Med Bite <input type="checkbox"/> Other _____			

Front Suspension

Toe: 2 degrees OUT
Ride Height: 30mm
Camber: -1 degree
Caster: Stock/20 degrees
Sway Bar: 1.8mm
Piston/Oil: 4 holes @ 1mm/30 wt
Spring: Black/Medium
Limiter/Droop: _____
Overall Shock Length: 86mm Center to Center
Steering Ackerman: Long
Bump Steer: Down
Camber Link: Position 2
Shock Location: Position 2 / Center
Front Diff Fluid: Grease
Receiver Battery Type: 1000mAh
Center Diff Fluid: Grease

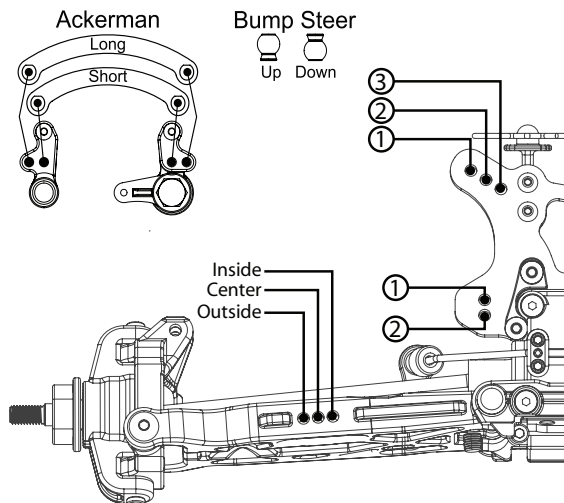

Notes: **Use 1.6mm Sway Bar for more steering**

Rear Suspension

Toe: 3 degrees
Anti-Squat: 2 degrees
Ride Height: 32mm
Camber: -1.5 degrees
Rear Hub Spacing: 2 spacers on both sides
Sway Bar: 2.0 mm
Piston/Oil: 4 holes @ 1mm/30 wt
Spring: Black/Medium
Limiter/Droop: _____
Overall Shock Length: 102.4mm Center to Center
Camber Link: Position 2 - B
Shock Location: Position 2 - Center
Rear Diff Fluid: Grease

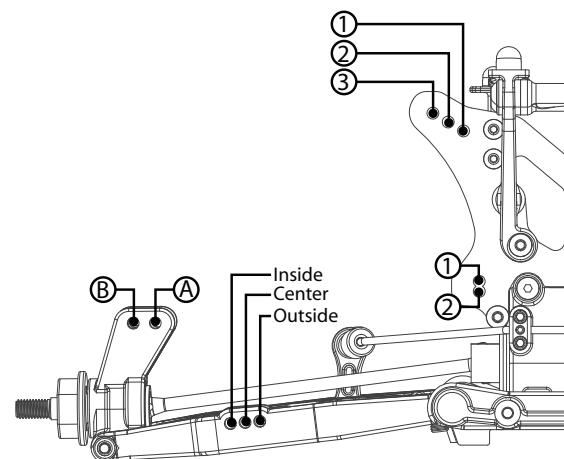

Notes: **Move rear hubs back for more on-power steering**

Engine

Engine: Losi 3.4	Fuel: Nitrotane 20%
Glow Plug: _____	Head Clearance: Stock
Pipe/Header: Stock	Gearing: 17/48

Notes
