

U.S. M151A2 FORD MUTT

ITEM 35123

TAMIYA

FORD IS A REGISTERED TRADEMARK OWNED BY FORD MOTOR COMPANY AND IS BEING USED PURSUANT TO PERMISSION GRANTED BY FORD MOTOR COMPANY.

«Marine Corps Version»

«Army Version with Machine Gun»

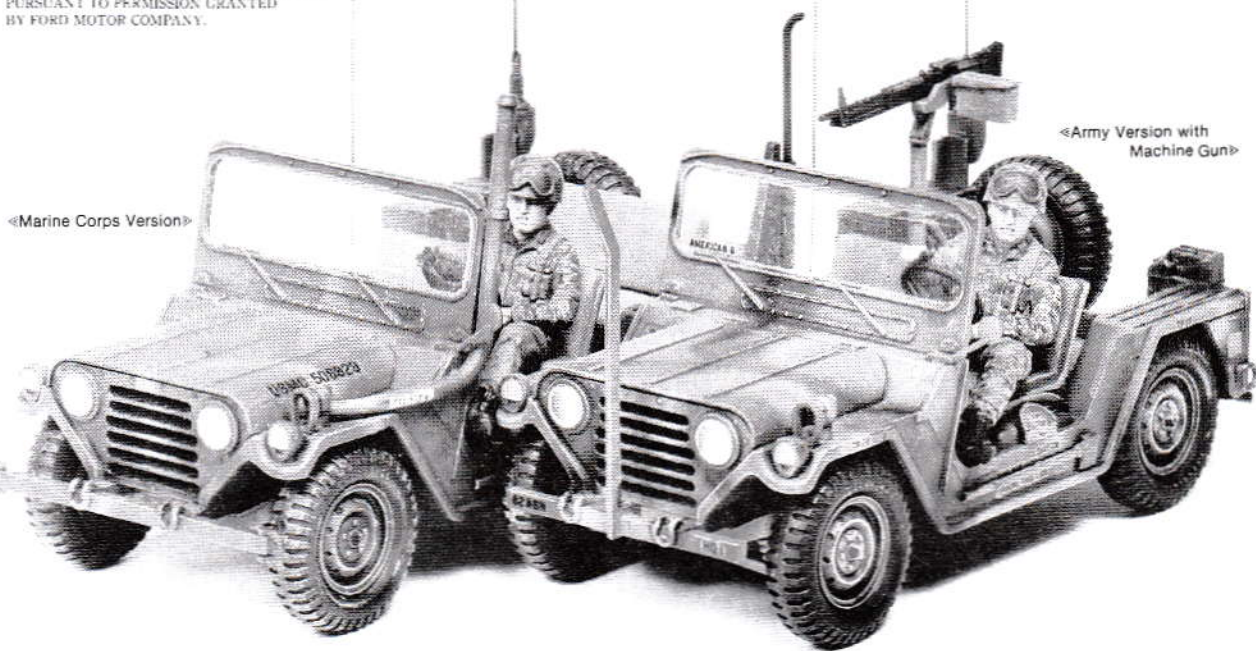

• Kit includes parts to be assembled into one vehicle.
 • Der kit enthält Teile für ein Fahrzeug

The US Armoured vehicle test course is located in Aberdeen, Maryland, and is one of the most rigorous and demanding courses in the world. Early in April 1957, a familiar looking small vehicle was seen to be running over the course with comparative ease, and upon closer inspection it turned out to be the replacement for the well known Willys "Jeep", the new Ford M151. Outwardly this new vehicle looks very much like its older brother. Both are small, compact, rugged, simple to operate and maintain; however, the 151 incorporates all of the latest advanced features learned during combat operations in conflicts since world war II. Features such as the newly developed OHV engine, light semi-monocoque body and 4 wheel independent suspension systems allowed it to outpoint all other submitted replacement vehicles for the ageing WWII Jeep. Development of this replacement vehicle was started by the Ford Motor Company and the U.S. Army jointly beginning in 1953. In July 1957 the M151 was officially adopted as the replacement vehicle for the M38A1 Jeep. Kaiser Industries and the American Motor Company were licensed to produce the vehicle and they delivered approximately 10,000 units a year to the U.S. Army, Navy Air Force and Marines. Shortly after its adoption it was selected by most of the nations of the free world as a replacement for their own light utility vehicles. Some of the advanced features incorporated into the M151 caused problems and defects were detected in the initial shipments, among the most serious was the strength and stability of the rear suspension system which was corrected and improved in 1964 and 1970. The M151A2 now in service has added safety features like stiffer rear suspension, large blinker lamps and a two step windshield wiper, safety glass and an impact absorbing steering wheel. With its extreme versatility, the basic M151 can be altered to a combat ambulance; radio communications vehicle; 105mm recoilless rifle transport and a launcher for the new tow missile system adopted

in the late 70's. Combat experience in Viet Nam has shown that the Ford M151 Military Utility Tactical Truck (MUTT) is indeed a very versatile go anywhere combat weapon and is likely to remain in service for years to come with military forces worldwide.

* * *

In Aberdeen, Maryland, liegt das US Erprobungsgelände für gepanzerte Fahrzeuge. Es dürfte das härteste Gelände der Welt sein. Anfang April 1957 fuhr ein kleines Fahrzeug über die Strecke, schaffte die Schwierigkeiten und nach näherer Betrachtung erkannte man den Nachfolger des berühmten Jeep von Willys, den neuen Ford M151. Das Äussere dieses neuen Fahrzeuges ist vergleichbar mit seinem älteren Bruder, dem Jeep. Beide sind schmal, kompakt, reine Zweckfahrzeuge, leicht zu bedienen und zu unterhalten. Der M151 aber hat alle neuesten Ausführungen, die man im Einsatz nach dem zweiten Weltkrieg für erforderlich hielt: den erst vor kurzen entwickelten OHV Motor, den leichten, selbsttragenden Aufbau und die 4-Rad Einzelaufhängung. Die Entwicklung dieses neuen Jeep begannen 1953 bei den Ford Werken, zusammen mit der US Armee. Im July 1957 wurde der M151 als

Nachfolger der M38A1 Jeep offiziell vorgestellt. Kaiser Industrie und die American Motor Company erhielten die Lizenz dieses Fahrzeug herzustellen. Es wurden ca. 10.000 Fahrzeuge im Jahr an die US Armee ausgeliefert. Das neue Fahrzeug wurde auch an die Navy, Air force und an die Marines geliefert. Kurz danach übernahmen auch die Länder der freien Welt dieses kleine Fahrzeug als leichtes Gebrauchsfahrzeug. Es wurden einige Defekte und Probleme entdeckt, darunter die Stärke und Stabilität der hinteren Aufhängung, diese wurden jedoch 1964 und 1970 verbessert und ausgeschlossen. Der M151, jetzt im Dienst hat einige Sicherheitsausführungen bekommen wie versteifte Hinterradaufhängung, grosse Blinker, Sicherheitsglas, 2 Stufen Scheibenwischer und ein stossfreies Steuerrad. Das Fahrgestell kann einen Aufbau als Ambulance, Funk, für rückstossfreies Geschütz oder für die neuen Wurfrahmen erhalten. Einsatzserfahrungen in Vietnam zeigten, dass der Ford M151 Militär Utility Tactical Truck (Mutt) ein vielseitig in jedem Gelände einsetzbares Fahrzeug ist und wohl für Jahre beim Militär im Einsatz bleiben wird.





**READ BEFORE
ASSEMBLY.**
**ERST LESEN
— DANN BAUEN.**

★ Study the instructions, drawings and photographs before commencing assembly.

★ You will need a sharp knife, a screwdriver, a file and a pair of pliers.

★ Use cement sparingly. Use only enough to make a good bond. Apply cement to both parts to be joined.

● This mark shows the colour. Colour numbers denoted in instructions are available in Tamiya Acrylic Paints.

★ Vor Beginn die Bauanleitung studieren und den Nummern nach die Elemente zusammenbauen.

★ Bauteile nicht vom Spritzling abbrechen, vorsichtig abschneiden oder abzwicken Teil vor Kleben zusammenhalten, auf genauen Sitz achten. Nicht zuviel Klebstoff verwenden. Kleine Teile hält man mit Pinzette fest.

★ Abziehbilder vorsichtig von der Unterlage im Wasser abschieben, auf richtigen Sitz achten und gut trocknen lassen.

● Dieses Zeichen zeigt die Farbe und Farbnummer der Tamiya Acryl-Farben.

3 <Assembly of Wheels> <Räder>

★ Make 4 sets
★ 4 Satz machen.

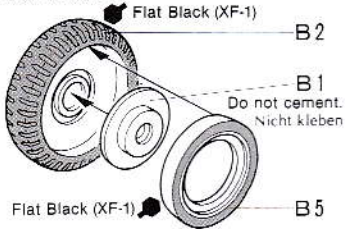

<Spare Wheel> <Ersatzrad>

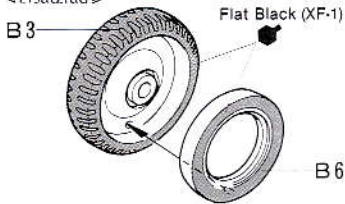

<Seat> ★ Make 2 sets
<Sitz> ★ 2 Satz machen.

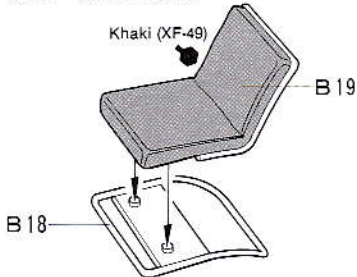

1 Body Assembly 1 Karosserie Montage 1

★ This kit can be assembled into Army (with machine gun) or Marine Corps version. Refer to page 5/6.

★ Dieser Kit kann gebaut werden als Army (mit M.C.) oder als Marine Corps Version (Seite 5/6)

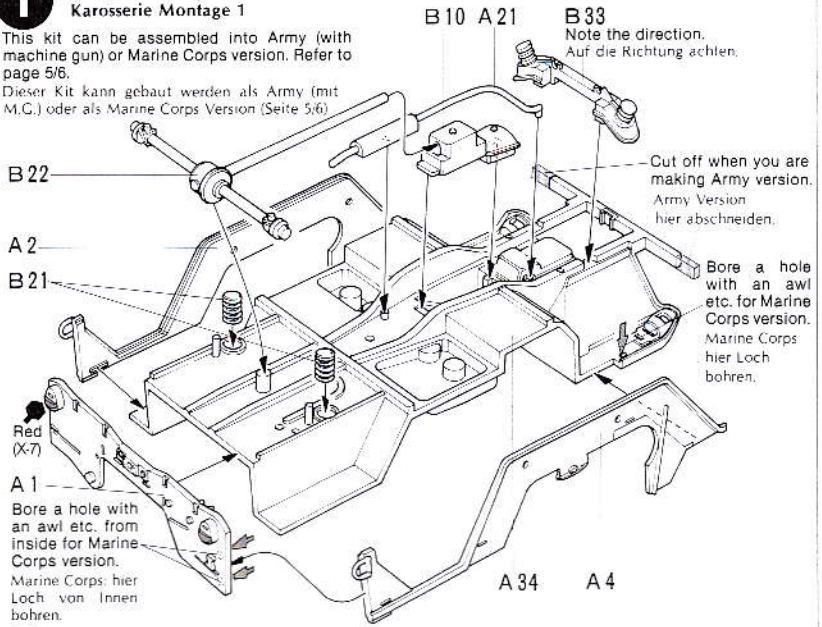

2 Body Assembly 2 Karosserie Montage 2

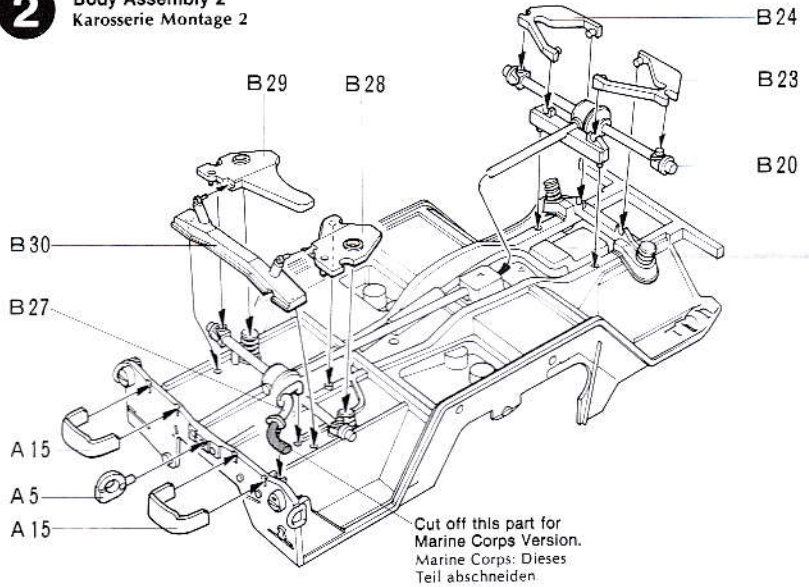

3 Attaching Wheels Einbau der Räder

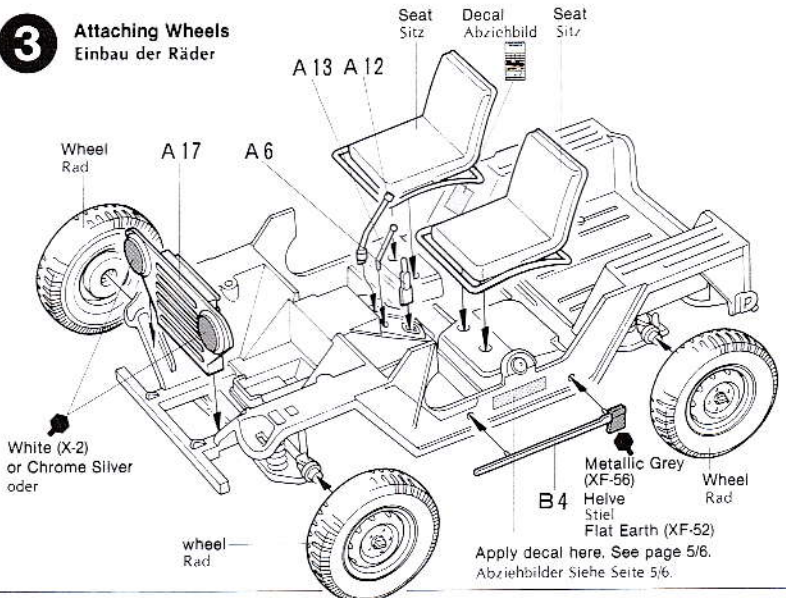

«Front Window»

«Frontscheibe»

Front window can be down. Cut off shaded part as shown if you prefer it down. When Frontscheibe abgeklappt eingebaut wird, dunkle Fläche abschneiden.

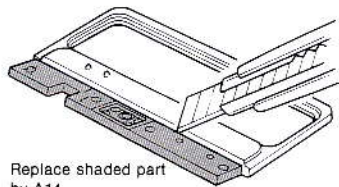

Replace shaded part by A14.

Cut out window as shown. Scheibe wie gezeigt ausschneiden.

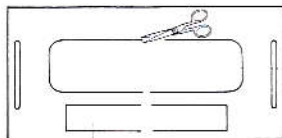

Place for Arizona National Guard Decal. Nummernschild für Arizona National Guard.

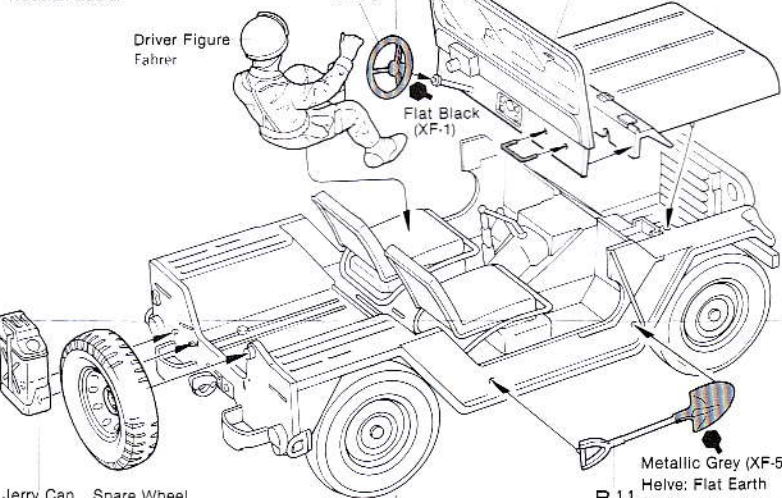

Jerry Can Spare Wheel
Kannister Ersatzrad

«How to make Antenna»
«Antennenbau»

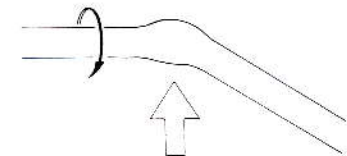

Heat a length of sprue. When melted a little, stop heating and pull to stretch it. Hold for about 15 seconds to cool and cut to proper length.

Ein Stück vom Spritzling über Kerze gerade biegen. Dann in der Mitte im Drehen erhitzen. Wenn Plastik schmilzt, nicht weiter erhitzen und langsam auseinanderziehen.

PAINT MARKER

Hand held, Tamiya enamel paint markers. For the final detail touch, and professional results. 12 of the most popular colors used in modeling. See and test them at your local hobby supply house.

4 Front Window
Frontscheibe

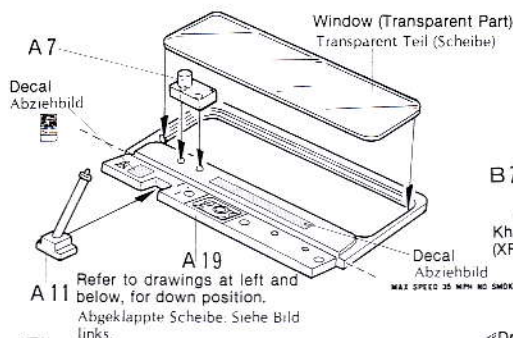

5 Attaching Front Window
Einbau der Frontscheibe

Front Window Frontscheibe A3 Flat Black (XF-1) A18
Affix after positioning front window.

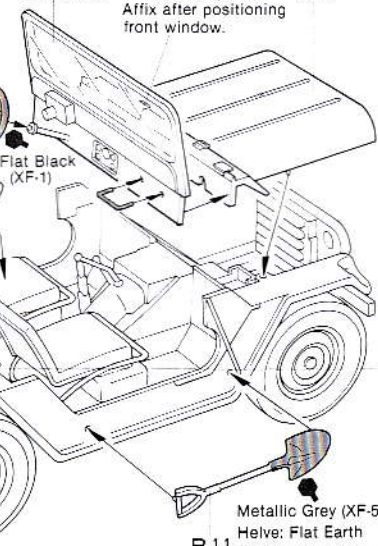

B11 Metallic Grey (XF-56)
Helm: Flat Earth (XF-52)
Stiel

«Jerry Can»
«Kannister»

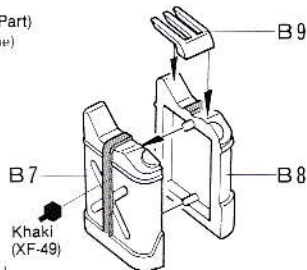

«Driver Figure»
«Männchenbau»

Refer to page 6 for drivers uniform painting. Bemalung der Uniform. Siehe Seite 6.

Black (X-1)
B13
Shirt: Flat Green (XF-5)
B14
B16
B15
B17
Belt: Khaki (XF-49) + Flat Green (XF-5)
Decal Abziehbild (The 82nd Airborne Div)

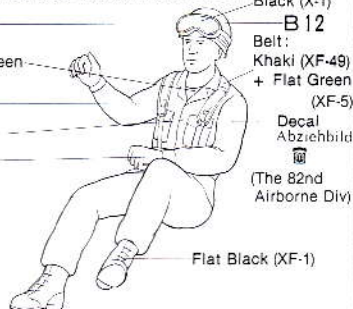

«Front Window — Down Position»
«Frontscheibe abgeklappt»

Attach B32 now. Rückspiegel B32 zuerst ankleben. Front Window Frontscheibe A18

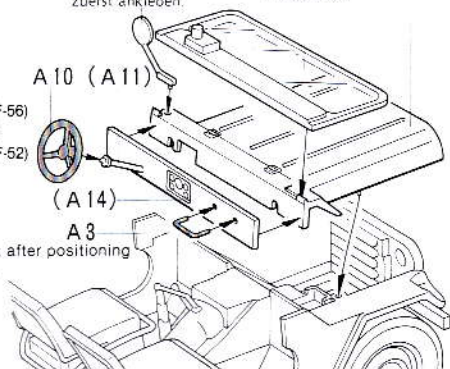

6 Attaching Front Parts
Einbau der Frontteile

* Army version — vehicle is completed in this step. Accessories are attached in step 7.
* Army Version Endmontage. Zubehör einbau siehe Step 7

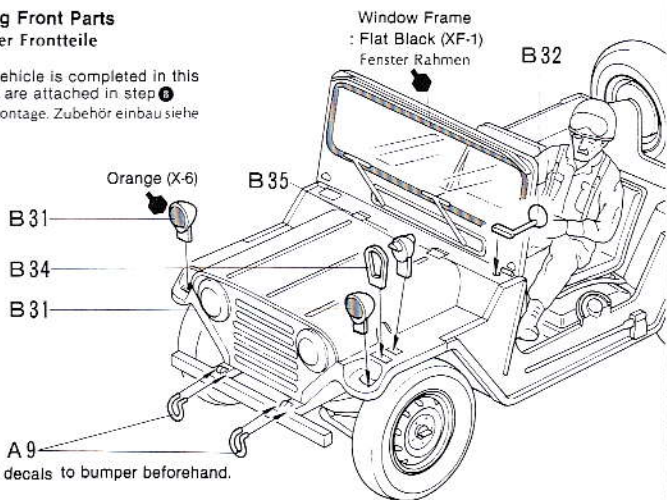

A9 Apply decals to bumper beforehand.

«Army version — with Machine Gun»
 «Army Version — mit M.G.»

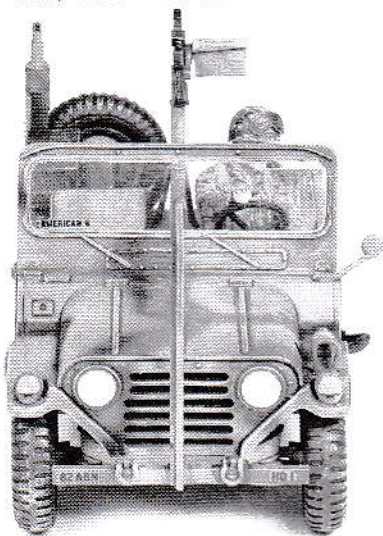

«Marine Corps version»
 «Marine Corps Version»

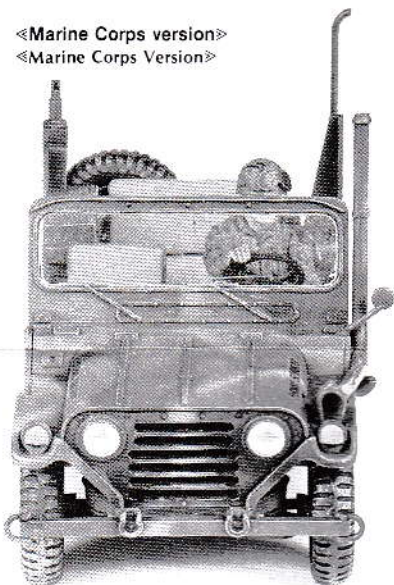

8 «Assembly of Accessories»
 «Zubehör»

«Rear Seat»
 «Rücksitze»

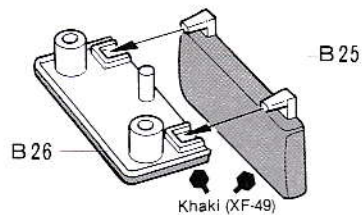

«Radio»
 «Radio»

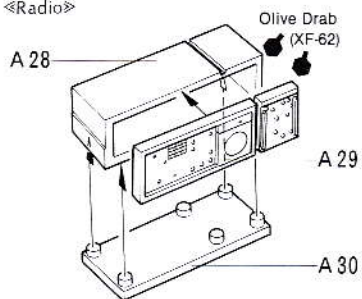

7 Final Assembly
 Endmontage

«Army version — with Machine Gun»
 «Army Version — mit M.G.»

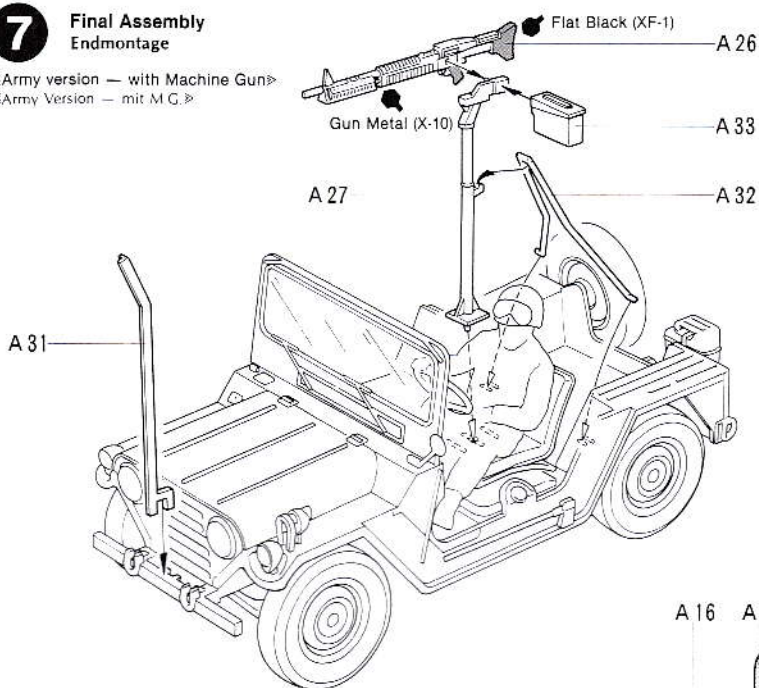

«Marine Corps version»
 «Marine Corps Version»

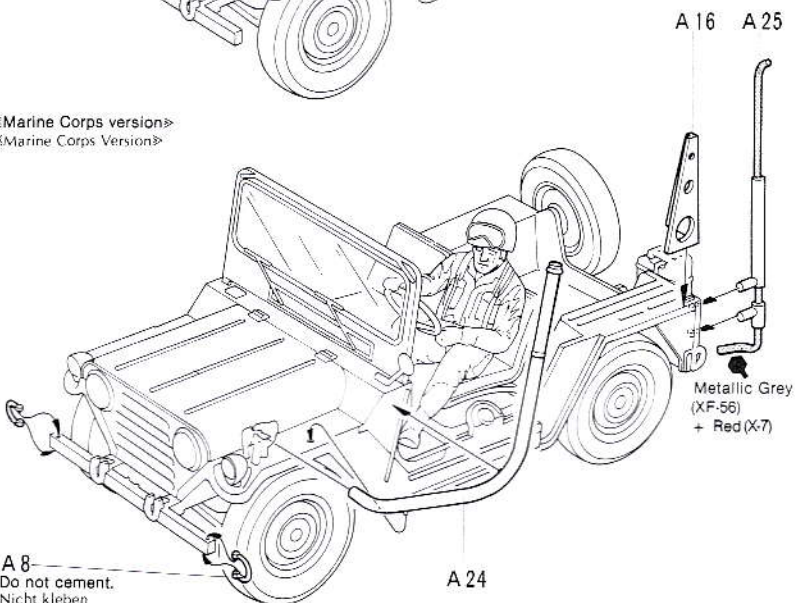

A 8
 Do not cement.
 Nicht kleben

8 Attaching Accessories
 Zubehör

★ You can attach radio and rear seat if you like, however, be sure to affix A20, A22 and A23 if you install radio.

★ Wenn Sie wollen, können Sie Radio und Rücksitze einbauen. Beim Einbau von Rücksitze einbauen. Beim Einbau von Radio, Teile A22 und A23 nicht vergessen.

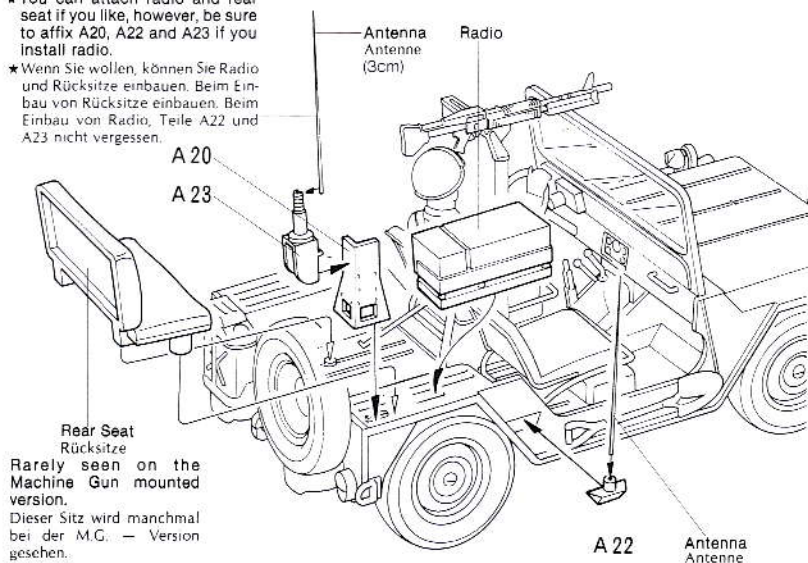

Rear Seat
 Rücksitze
 Rarely seen on the Machine Gun mounted version.
 Dieser Sitz wird manchmal bei der M.G. - Version gesehen.

PAINTING

«Painting of M151A2 Ford MUTT»

Both U.S. Army and Marine Corps adopt standard 12 colours of white, sand, dark green, forest Green, black etc. for their painting of vehicles. The Ford MUTT is painted in a camouflage scheme composed of 4 of the 12 colours. The Army version utilize various camouflage schemes according to season or place, and the Marine Corps use only 3 patterns based on green and sand. Refer to drawings at right or box sides for camouflage colour scheme. All marks, numbers and letters are done in black. The detail painting including driver figure is denoted in each step and called out during assembly.

«Bemalung des M151 Ford Mutt»

U.S.Army und Marine Corps verwenden 12 Standard Farben wie weiss, sand, dunkelgrün, schwarz, olive drab usw. für die Bemalung ihrer Fahrzeuge. Der Ford Mutt ist mit vier Farben getarnt. Die Armee verwendet diese Tarnfarben je nach Jahreszeit, Gelände oder Einsatzort, das Marine Corps hat nur drei Tarnmuster auf grün oder sand. Bezüglich Bemalung siehe Bilder rechts oder Karton-Bilder. Detailbemalung siehe einzelne Baustufen.

Army version — with Machine Gun «The 82nd Airborne Div.» «The 2nd Infantry Div.»

Army Version — mit M.G.

«82. Luftlande Division, Die 2. Infantry Div.»

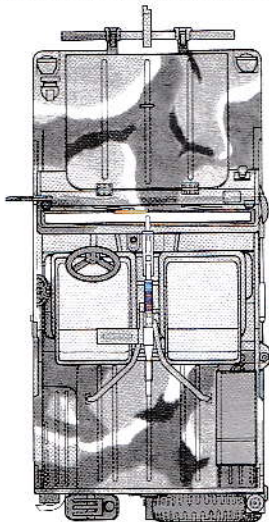

(common)

Marine Corps version «U.S. Marine Corps in Japan — Camp Fuji»

Marine Corps Version

«U.S. Marine Corps in Japan — Camp Fuji»

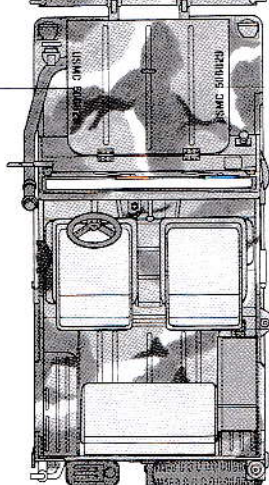

(common)

Army version with Machine Gun «The 82nd Airborne Div.» «The 2nd Infantry Div.»

Army Version — mit M.G. 82. Luftlande Division, die 2. Infantry Div.

Red Brown (XF-64) + Flat White (XF-2) Buff (XF-57) + Flat White (XF-2) Field Grey (XF-65) Flat Black (XF-1)

*(82) stands for the 82nd Airborne Div. and (2) stands for the 2nd Infantry Div.

Select either of them.

*(82) steht für 82. Luftlande Division, (2) steht für 2. Infantry Division

AMERICAN 8 (82)

Flat Black (XF-1) or Body Colour

TP-20 (common)

Gun Metal (X-10)

TP-25 (common)

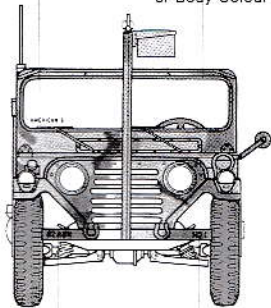

82ABN (82)
2H29 (2)

HQ 1 (82)
CS25 (2)

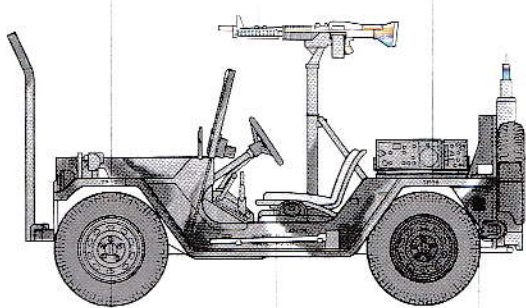

Red Brown (XF-64)
+ Flat White (XF-2)

DO NOT FILL ABOVE THIS LINE

(common)

(common)

Field Grey (XF-65)

(common)

Red Brown (XF-64)
+ Flat White (XF-2)

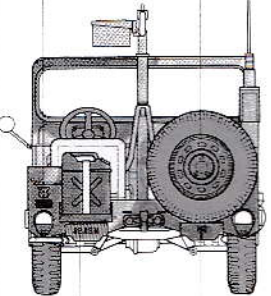

82ABN (82) 2 H29 (2) HQ 1 (82) CS25 (2)

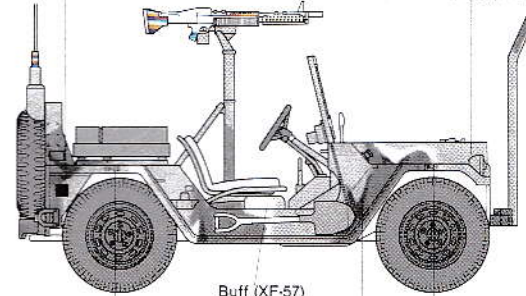

Buff (XF-57)
+ Flat White (XF-2)

Flat Black (XF-1)

TP-20 (common)

Marine Corps version «U.S. Marine Corps in Japan — Camp Fuji»

Marine Corps Version U.S. Marine Corps in Japan — Camp Fuji

Olive Green (XF-58) + Flat white (XF-2) Olive Green (XF-58) + Khaki Drab (XF-51) Flat Yellow (XF-3) + Olive Green (XF-58) Flat Black (XF-1)

Flat Black (XF-1) or Body Colour

506829

Olive Green (XF-58)
+ Khaki Drab (XF-51)

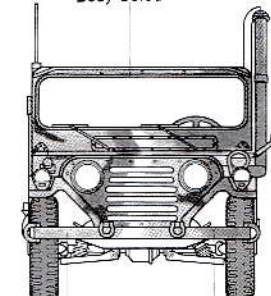

Olive Green (XF-58)
+ Flat White (XF-2)

Olive Green (XF-58)
+ Khaki Drab (XF-51)

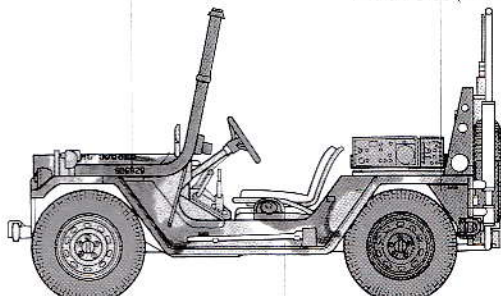

Flat Yellow (XF-3)
+ Olive Green (XF-58)

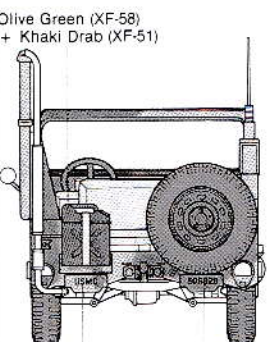

Olive Green (XF-58)
+ Khaki Drab (XF-51)

Olive Drab (XF-62)

Olive Green (XF-58)
+ Flat White (XF-2)

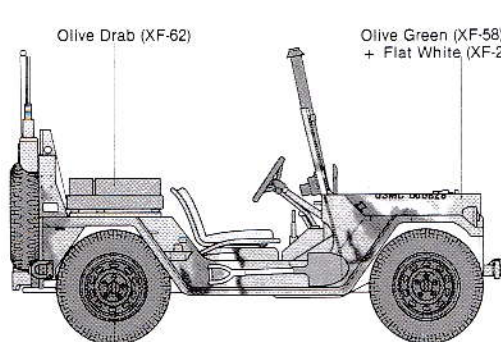

Olive Green + Khaki Drab (XF-58) (XF-51)

◀Decal Application▶

(1) Remove all dust, dirt and adhesive smears with a wet cloth before applying any decals.

(2) The decal to be applied should be removed beforehand from the decal sheet. Cut off translucent films along coloured parts.

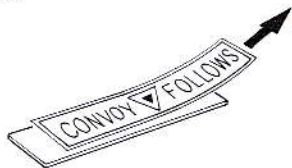

(3) Dip the decal in tepid water for about 10 seconds and then remove it onto a clean cloth. Be careful of over immersion to avoid loss of decal's adhesive.

(4) Hold the backing sheet edge and slide the decal onto the model.

(5) Wet the decal with a little water on your finger so that it can be moved more easily into position.

(6) Press the decal down gently with a clean soft cloth to remove air bubbles and until all excess water has been fully absorbed. When a decal has to be applied to a surface which is uneven or curved, press the decal down with a hot towel so that the decal will fit the contours perfectly. Cut off the excess transparent portion around each decal. The decal must then not be touched until dry.

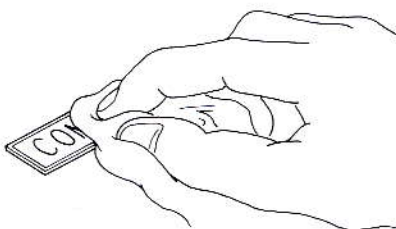

◀Abziehbilder-Decals▶

(1) Staub, Schmutz und Klebstoffreste mit nassem Tuch entfernen.

(2) Decals erst ausschneiden entlang den Linien.

(3) Decals in Wasser legen, dann nach 10 Sekunden auf z.B. Handtuch legen und etwas abtrocknen lassen.

(4) Decal an der Unterlage halten und Bild auf das Modell schieben.

(5) Mit etwas Wasser auf dem Finger lässt sich das Decal noch etwas verschieben.

(6) Decal mit etwas Stoff gut andrücken um die Luftblasen zu entfernen und das Wasser abzutrocknen. An unebenen Stellen kann man mit heissem Tuch das Decal besser andrücken. Transparente Überreste am Decal abschneiden. Decal nicht mehr berühren, bis getrocknet ist.



Tamiya Acrylic Paints

Need precise colour matching? Try the new Tamiya acrylic paints. Engineered by modelers for modeler's use. The final cover for the finest models. Insist on Tamiya for perfect results.

Tank photo albums

Like to super detail that tank? Check out the latest Tamiya tank album for the finest in detailed photos of most of the popular tanks.

TAMIYA COLOR CATALOGUE

The latest in cars, boats, tanks and ships. Motorized, radio controlled and museum quality models are all shown in full color in Tamiya's latest catalogue. At your nearest hobby supply house.



Army version — ◀Arizona National Guard▶ ◀3rd Armoured Div.▶

Army Version Arizona National Guard, 3 Armoured Div.

Same colour scheme as Army version with Machine Gun

Bemalung siehe Army Version — mit M.G.

★ (A) stands for Arizona National Guard, and (3) stands for the 3rd Armoured Div. Choose either.

★ (A) steht für Arizona National Guard, (3) steht für 3 Armoured Div.

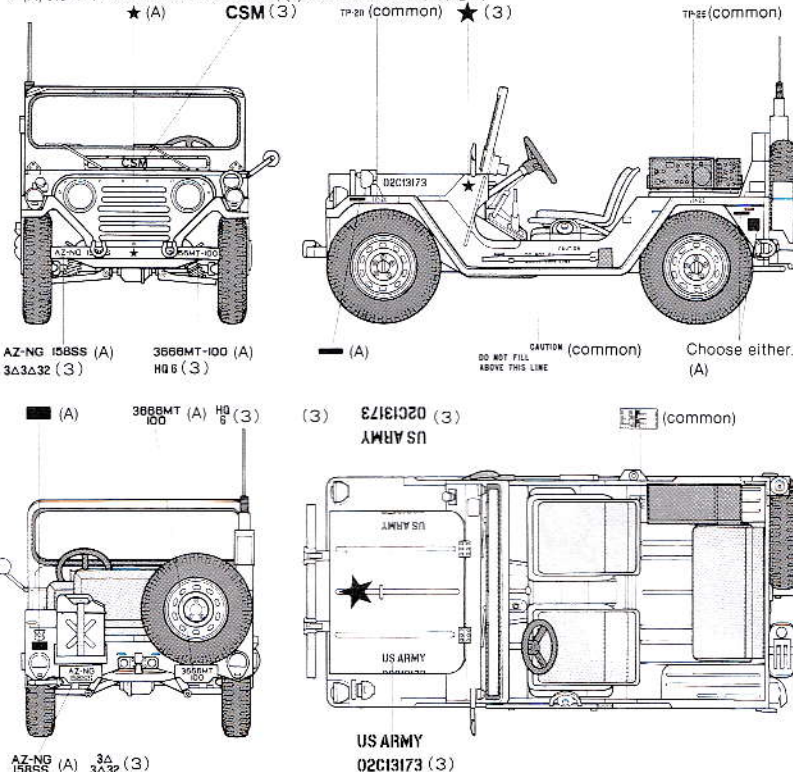

◀Painting of Camouflage Suit▶

◀Bemalung der Uniform▶

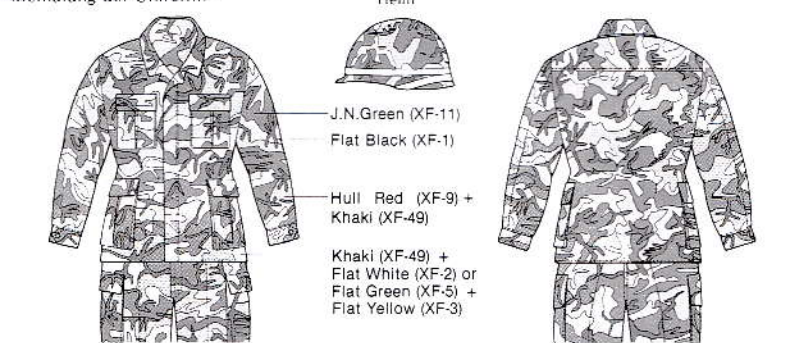

◀Army version▶ Arizona National Guard

The sign is carried by leading vehicle of a convoy. You can attach it also to the machine gun mounted version. Apply decal to transparent sheet cut out in step 4.

