

# 1927 PHILLIPS 66 OIL TANK WAGON

design, instructions and prototype by Ken Goldman

1:12 scale 6 1/4" high, 11 1/2" long, 5 3/4" wide

Although long established in the petroleum industry, the Phillips Petroleum Company was a rather late entry in the retail end of the business. Once the decision had been made to directly market their products under their own banner, the problem remained as to just what that banner would look like. The story goes that in 1927, while road testing the company's gasoline, the company representative turned from watching the scenery flash by and commented to the driver that they were "going like 60." The driver looked at the speedometer and replied, "Sixty nothing. ...we're doing 66!" The highway on which they were effortlessly speeding was U.S. Highway 66 near Tulsa, Oklahoma. The coincidence was too good to resist, and the brand name was born.\*

\*Aaseng, Nathan, *Business Builders in Oil*. The Oliver Press, Inc., 2000, p. 104

Though the age of the motor vehicle was well established, most local roads, particularly in the south and southwest, even in 1927, were still back in the horse and buggy age. Local distributors of gasoline, kerosene and lubricating oil found it more convenient to use hay-burning vehicles to deliver their products to local gas stations. There was little uniformity in the design of these horse-drawn oil tank wagons. The one represented by this kit is based on an actual wagon of the period, which road on a modified Studebaker wagon chassis. Some wagons were fitted with a buggy canopy to protect the driver from the elements. This particular one has a socket for a market umbrella, much like what one would use today for shade on a patio. The tank itself would have been custom welded with separate compartments and plumbing for the three products listed above.

## **BEFORE YOU BEGIN**

Clean off mold seams in the castings and fret tabs on laser-cut wood with a #10 hobby knife, needle files and sanding sticks and drill out holes that may be clogged. A #66 drill will clear all the small holes and use a 3/32" drill to clear the holes in the axle ends and holes through the pivot and half chairs. Wash all cast parts with Windex or similar to remove residual mold release. Clean off charring from the laser cutting process before attempting to glue such parts together. Soot makes a poor glue joint.

Familiarize yourself with all of the parts and photographs. If something is a bit unclear to you in one photograph another will likely answer your question. For best results follow the instructions in the sequence they are presented.

Because this is a multimedia kit dimensional discrepancies may arise. Always dry fit parts and make any minor adjustments as necessary. It is more important that the completed model look right than any of the given dimensions match exactly.

All holes for escutcheon pins are #66, those for small brass nails are #74. In general where an escutcheon pin directly enters and/or exits wood a card washer is used. Three exceptions to this are the coupler bracket, coupler plate and brake spring spacer which, though laser-cut plywood, represent steel parts. Card rub plates from laser-cut card stock also are considered to represent steel fittings and do not get card washers unless so specified in the instructions. Square nuts laser cut from gasket material are referred to as nuts. Britannia cast metal square nuts are referred to as cast nuts. Trim off all excess length of escutcheon pins and U-bolts so they just protrude through the square nuts that secure them.

Securing nuts are always glued in place with cyanoacrylate glue, CA. The finished model will look better if these cut ends are ground flat. Use wood glue to join wood parts, CA or Epoxy for all others. Epoxy is recommended in some places. Use mid cure CA to bond castings to wood. If you only have the thin stuff, prep the wood with a drop of CA that you allow to sink in. For better adhesion, rough up castings surfaces that will lie in a glue joint. You will also need Plastruct Plastic Weld or similar model glue to join plastic parts. Most clamping can be done with spring clothespins.

## WHEELS

Both the large and small wheels are constructed in the same manner. Note that the spokes for the large wheels (14 per wheel) are straight with a small arc cut out of the hub end. Those for the small wheels (12 per wheel) have a similar arc at their wider, hub, end. The cast resin hubs are the same for all four wheels.

Cut free and sort all the wood parts. Sand the laser cut attachment spots flush with the part surfaces. Carefully file off the casting gates from the hubs. The wheels themselves consist of a notched wheel and two scored faces that represent the fellows (wheel segments). Using water base wood glue, laminate one face to each wheel, making certain that the score marks on the faces are outward and that each score is centered between two notches on the plywood wheels. Spring clothespins make good surface clamps.

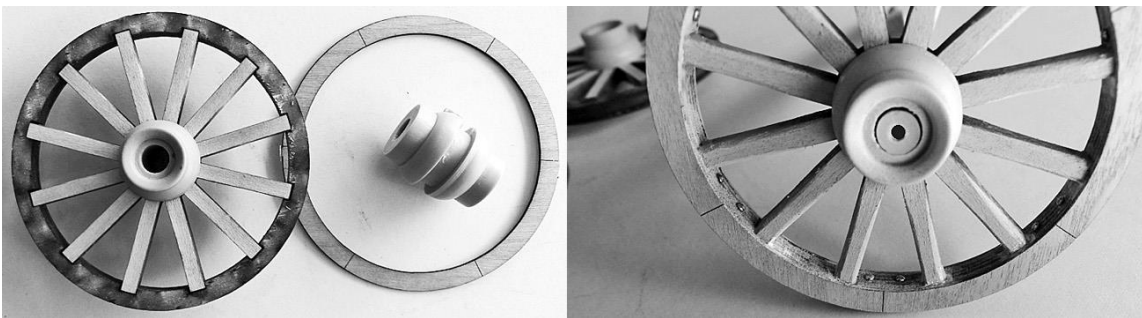

Insert the arced end of the spokes in the hubs. The correct number will fit snugly into the center of each hub. Drop the spoke subassembly into the notches within the appropriate wheel rim. Twist the hub slightly to correct any misalignment of the spokes. Opposing spokes should form a straight line. Laminate the other face in place to lock in the spokes. Be sure that the fellows scoring lines up with the already laminated faces.

Use a sanding stick or a needle file to round over the corners of the spokes, starting about 1/8" from each hub, right to the rim. There is a slight amount of play in-and-out pushing on the hub. With the cupped hub end facing out push in the hub, then glue the spokes in place with a drop of diluted wood glue at the rim end of each spoke. This results in a slight cup to the wheel. Fill any gaps around the spokes with putty or Spackle.

On the outside of the wheel rim, center a mark between each score line and its adjacent spoke, then drill in (#66 drill) completely through, angled to the hub center. Into each of these holes glue an escutcheon pin from the inside out, to represent the tire bolts. Precut each pin so it will not protrude through the outside of the rim.

Primer paint each wheel, keeping the hub hole clean, touch up any defects, fine sand off any raised wood grain, then paint the wheels white. Super glue a laser-cut gasket strip around the outside of each wheel to simulate the iron tire. Work your way slowly around the wheel until the tire ends overlap. Make a diagonal cut through the overlap to create a clean end joint. Note that the strips are of two lengths to correspond to the wheel sizes. Paint the wheels white. The tires are either black or a wrought iron finish.

## TANK

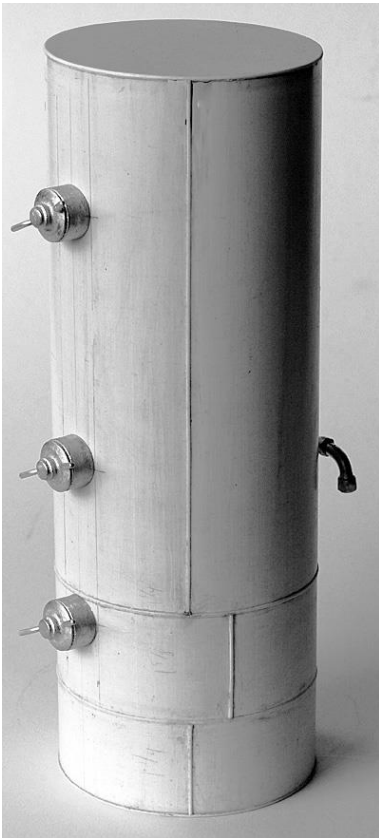

Lightly sand the surface of the PVC pipe to remove surface blemishes. Putty and sand smooth any gouge marks.

Strike a pencil line the length of the tube, parallel to its main axis, and another directly opposite the first one. From whichever end you decide is the front measure back 1 1/2" and make a cross mark on one pencil line. This will be the top. Measure back 4 1/4" from the front along the same line and make another mark. Repeat the process measuring back 6". These marks will locate the filler domes. On the opposite pencil line, measure back from the front and mark points at 2", 4 5/8" and 6 5/8". Drill a 5/32" hole through each of these points for the fuel pipes.

Measuring from the rear of the tank, strike a line around the circumference of the tube at 2 3/8" and another at 1 1/8". Razor saw into those lines around the tube to an approximate depth of 1/2 the thickness of the provided polystyrene rods. Widen the slots with a needle file so the rod will fit snugly. Glue and wrap a plastic rod in each slot using a plastic solvent glue such as Plastruct, then trim to length. This will form the tank extension weld

seams.

With the tube oriented front away from you, measure down to the right about 1 1/4" from the top line. Strike a line from the front to the back, skipping the space between the two weld seams. In the skipped space, measure down about 1 5/8" and strike a short line there. Cut grooves into these lines in a manner similar to cutting the circumferential weld seams. A Plexiglas cutter drawn along a straight edge will facilitate this. Glue in the remaining plastic rod to make the longitudinal weld seams.

Cut the provided plastic sheet in half and glue these to the ends of the tube. When thoroughly dry, trim the end pieces to fit the tube, but leaving a little excess to simulate the end weld seams.

Glue on the filler domes. For best results drill 3/16" holes at your locator marks but stop before you penetrate the tube. Use epoxy to attach the domes. The epoxy will form an anchoring peg inside the drilled holes.

NOTE the two grooves on the underside of the pipe flanges. These run parallel to the length of the tank when positioned properly over the pipe holes. Glue them in place. Glue the front and middle pairs of pipe elbows together per the photograph. NOTE that they form right and left pairs. The join should come out straight with the two ends set 90° from each other.



Set the tank subassemblies aside. Assemble the laser-cut rails and cradles of the WAGON BED. The three cradles fit in the rail notches, belly down, with the three-hole cradle rearmost and the one-hole cradle in the center.

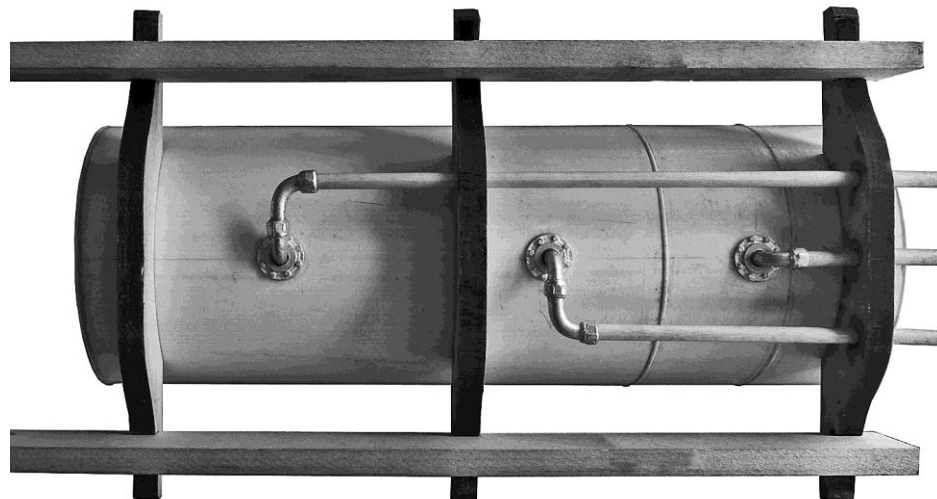

The partial wagon bed assembly is used here as a jig to position the pipe fittings and to

complete the tank assembly stage. Set the tank in the wagon bed cradle and run a dowel through the center cradle hole to align the rearmost, single pipe elbow. Epoxy the elbow in place, then repeat the process for the middle and then the front joined elbows. Leave the previously inserted dowels in place to ensure everything lines up properly.

HINT: You can use rubber cement to temporarily glue the dowels into the pipe elbows to facilitate the process. Dowels may be cut as needed to do this step, just be certain they extend from the pipe elbows well past the rearmost (three hole) cradle. They will be cut to finished length later. After the glue has cured remove the dowels and paint the tank subassembly orange.

### **RUNNING GEAR - FRONT**

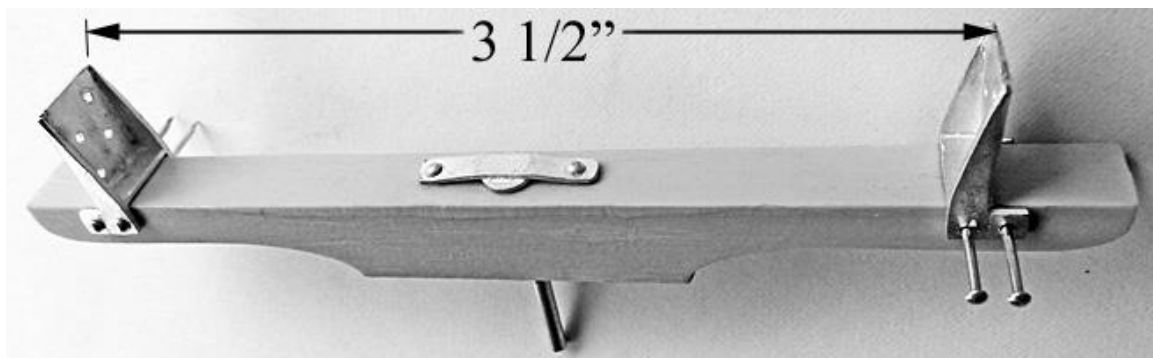

Make sure the center hole in the pivot chair is square to the part.

Measure out in both directions and draw lines across 3 1/2" apart. Per the above photograph, position bed brackets, flats against the lines, and mark and drill holes for escutcheon pins. We recommend you drill in part way from each side until opposing holes meet inside the chair. Pin but do not glue the brackets to the pivot chair using escutcheon pins. If your holes are off a bit drill the holes a little larger. The brackets will hide this. Glue in the kingpin. The tab ends of the retaining strap molded with the kingpin should be tight to the surface.

The steering yoke is composed of the axel, half chair, wood and metal braces and large and small arc steering stabilizers. For rapid identification, the rear axle, unlike the front one, has dimples in the braces channels. Glue the card rub plate arcs to their respective wood stabilizers, being careful to align the holes.

Using two large U-bolts, pin the front axle and half chair together with the front braces sandwiched in between. Tape around the axle and the half chair to temporarily hold this assembly together. Pin the stabilizers to the braces so the small stabilizer rub plate faces down, the large faces up, per the photograph. Use a card washer as a spacer between each rub plate and the braces. The attachment order, seen from above, is escutcheon pin, card washer, small stabilizer, rub plate, card washer/spacer, wood brace and, for now, some tape to hold it together. For the large stabilizer it goes pin, card washer, wood brace, card washer/spacer, rub plate large stabilizer, card washer and gasket nut. Check the alignment

of all the parts before gluing the arcs to the wood braces and the end washers and nuts to the large arc. Trim the excess pins' length on the large stabilizer arc only.

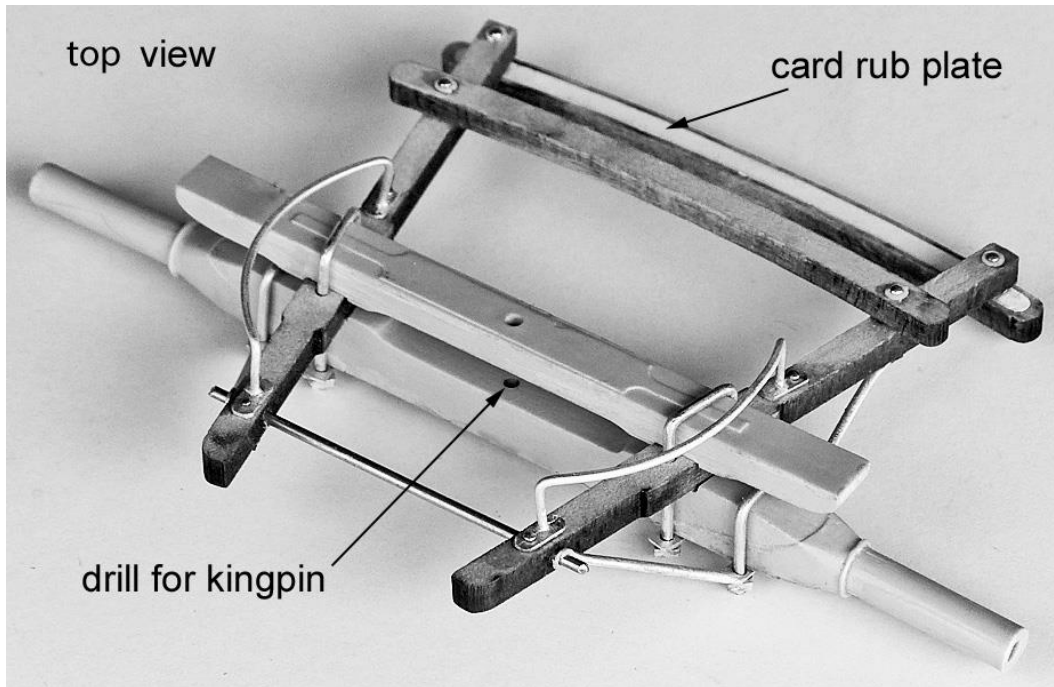

Use the kingpin hole in the half chair to mark the front axle for drilling. Remove the tape and drill a 3/32" hole ALMOST through the axle. Put it all back together and secure the U-bolts with U-bolt plates and cast nuts.

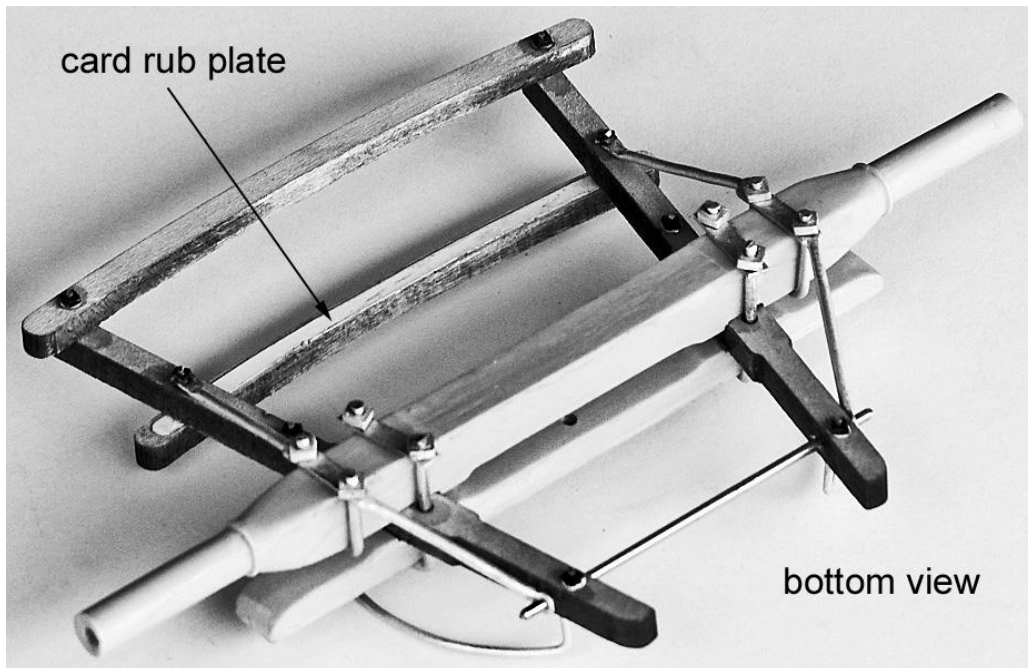

Measure out  $7/8$ " forward at a right angle to the front face of the axle and mark each brace. Drill a  $1/16$ " hole through each wood brace so a brass rod slipped through the holes will be parallel to the axle. The distance from the inside (square) end of either brace to the outside of the brass rod should be  $7/16$ ".

The metal front axle braces need to be bent slightly to form left and right elements. The ends with the ring slip over the  $1/16$ " brass rod, the other end goes over the escutcheon pin that protrudes through the small stabilizer and wood brace. Secure it with a gasket nut. The center is held against the axle by a small U-bolt and two cast nuts per side. The U-bolts will automatically locate themselves on the axle. Trim the U-bolt and escutcheon pin ends per the photograph. Cut a  $2\ 1/4$ " length from the  $1/16$ " brass rod, center in position and secure the metal brace rings with a large-hole gasket washer to the outside of the brace and a cast nut on each side.

Turn the subassembly right side up. Attach the two pivot guides by drilling through the wood braces and securing them to the top of the assembly with the usual escutcheon pins, card washers and gasket nuts. Drill for the front end first so the hole is just forward of the brass rod. Temporarily pin that end in place, then locate and drill the hole for the other pin. When assembled correctly, with the pivot chair in place atop the half chair the metal guides will define a circle with the kingpin at its center, and they will just touch the underside of the pivot chair. Finish this stage by painting the entire subassembly black.

## **RUNNING GEAR - REAR**

Start by making the coupler, the long central shaft. Cut a  $7\ 3/4$ " length from the  $3/16$ " x  $5/16$ " kit lumber and drill a  $3/32$ " hole on the  $5/16$ " side centered  $5/32$ " in from one end. This end will be the front. On the same side, drill centered #66 holes  $1\ 3/8$ " and  $2\ 11/16$ " from the front. Use these holes to escutcheon pin a card straight rub plate to each side, from top down. Secure the pins with gasket nuts.

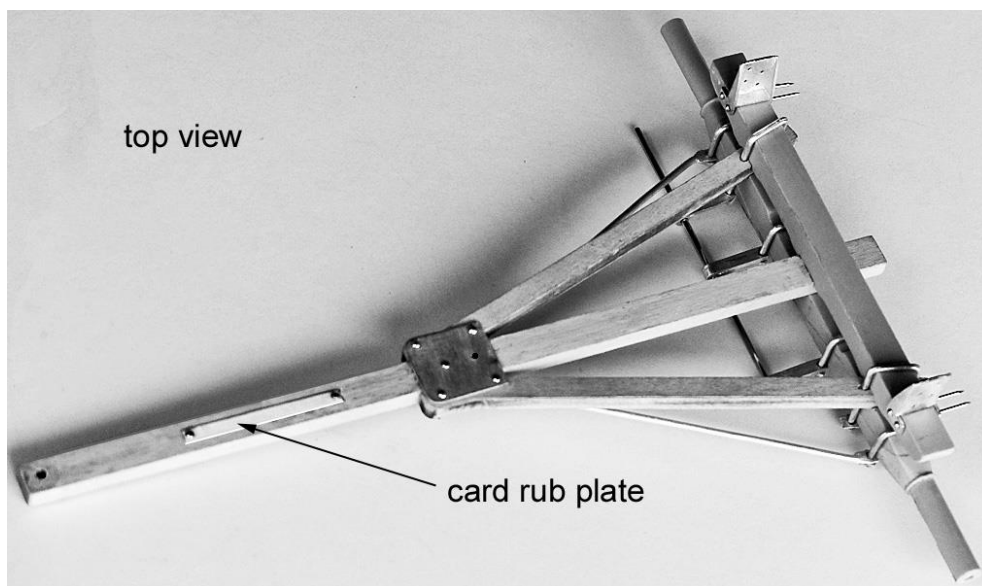

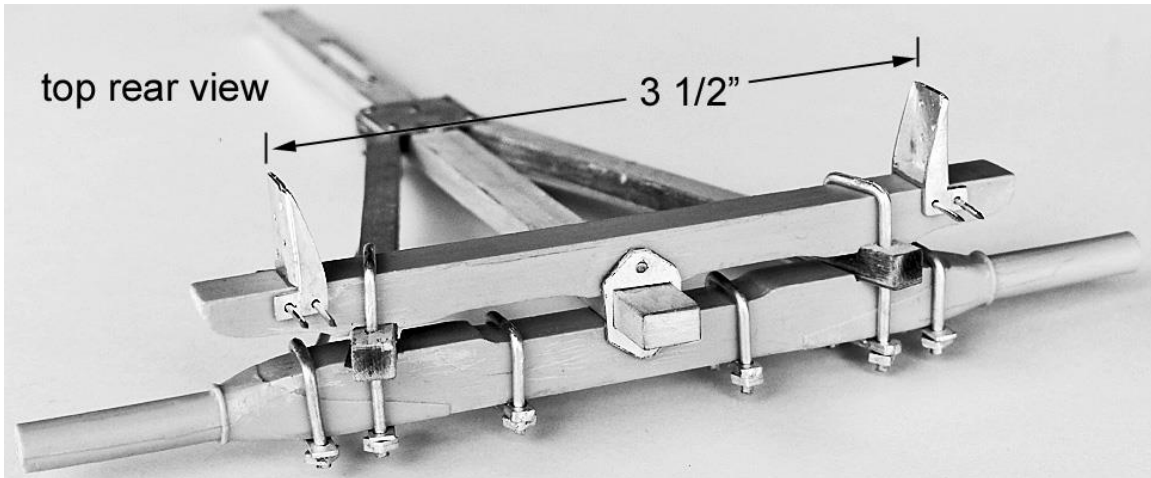

Drill the rear chair for the bed brackets as you did with the pivot chair and dry pin the brackets to the chair. Loose join the rear axle, rear chair and rear wood axle braces using large U-bolts and hold together with tape. Insert the rear end of the coupler through the center so it protrudes 3/8" past the outside rear of the axle. True everything up, then glue the axle braces to the coupler and then the coupler and braces between the axle and chair. Slide the coupler bracket over the coupler and drill #74 holes for two brass nails.

Glue the coupler plate atop the joints between the coupler and wood braces. At each hole in the coupler plate drill #66 holes completely through the coupler and braces. Turn it all upside down.

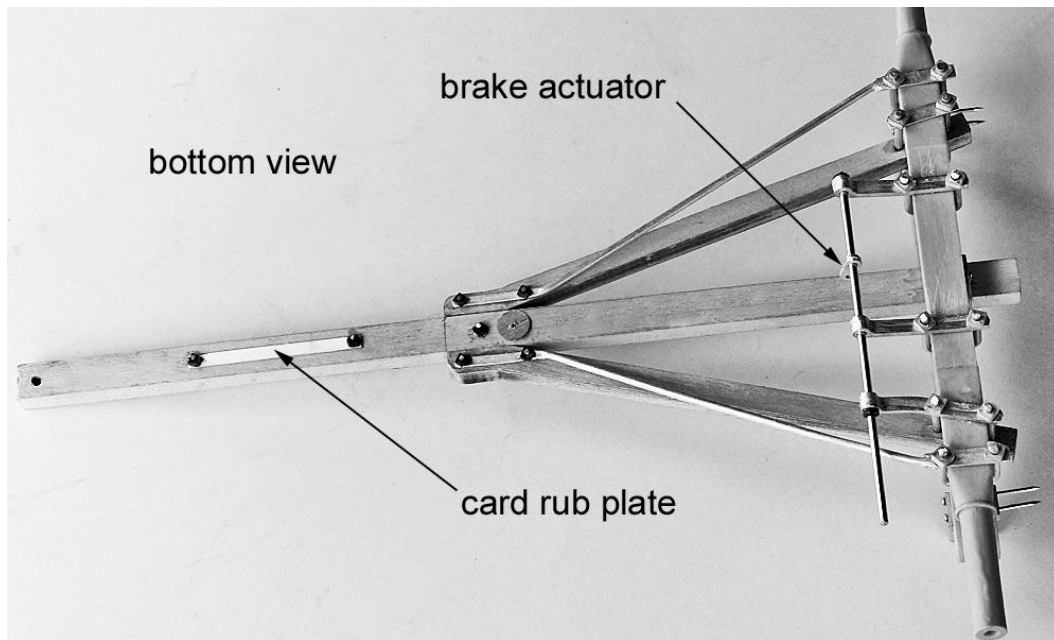

Secure the left-hand large U-bolt with a U-bolt plate and two cast nuts. Slip the angle shaft mount over the right-hand large U-bolt, but do not yet secure it. Slip a small U-bolt around the axle only on either side of the coupler and tape the three loose U-bolts in place. Refer to the middle photograph in this section for guidance. Slip a straight shaft



mount over each of the small U-bolts. NOTE: the shaft ends of all three shaft mounts hang down as seen from above. Run a 1/16" brass rod through the shaft ends, then true up and glue the shaft mounts to the U-bolts, using cast nuts, so the brass rod is parallel to the axle and the arms of the mounts are perpendicular to the axle. Remove the rod.

Run an escutcheon pin through each of the four outside holes in the coupler plate from top to bottom. Slip a small U-bolt over each end of the axle and temporarily tape in place. Position the cast metal axle braces per the above photograph. Some slight bending is required. The U-bolts will naturally find the right location when you remove the tape. Cut the U-bolts down so they just protrude through the square nuts. Glue a gasket nut over the pins at the coupler end of these braces, then cut the pins as before.

Run an escutcheon pin through the forward of the two center holes in the coupler plate and secure it on the underside with a card washer and a gasket nut. Center the laser-cut brake spring spacer on the underside, over the remaining coupler plate hole, and glue it in place.

Cut a 3" length of 1/16" brass rod and run it back through the shaft mounts with the addition of the cast brake actuator left loose between the two straight shaft mounts. Leave enough of the rod protruding through the left straight mount to secure it with a large-hole gasket washer. Secure the other end of the rod with another large-hole gasket washer just outside the angle shaft mount. Paint the subassembly black.

## **BRAKE ARM**

Mark the center on the straight side of a laser-cut brake shoe. Position a cast brake shoe bracket so the outer flat surface of the bracket aligns with the center line. Mark and drill #66 holes to join the shoe and bracket with two escutcheon pins finished off by two gasket nuts. Trim the excess from the pins, then repeat the process for the other one.



Slip the rear wheels on their axle and use them to position the brake shoe brackets on the brake arm. The midline of the brake shoes is approximately 7/32" from either end of the

arm. Mark and drill the three mounting holes for each bracket. The brackets rest on the top side of the brake arm. Insert escutcheon pins through the brackets and secure at the arm underside with card washers and a gasket nuts. Trim the pins as usual.

Referring to the above photograph, make two sets of two brass eyebolts joined by two brass split rings. Place the tabs of the cast brake return spring over the outer two laser-drilled holes in the brake arm and join it to the arm with a prepared eyebolt each. Secure the eyebolts on the underside of the brake arm card washers and gasket nuts.

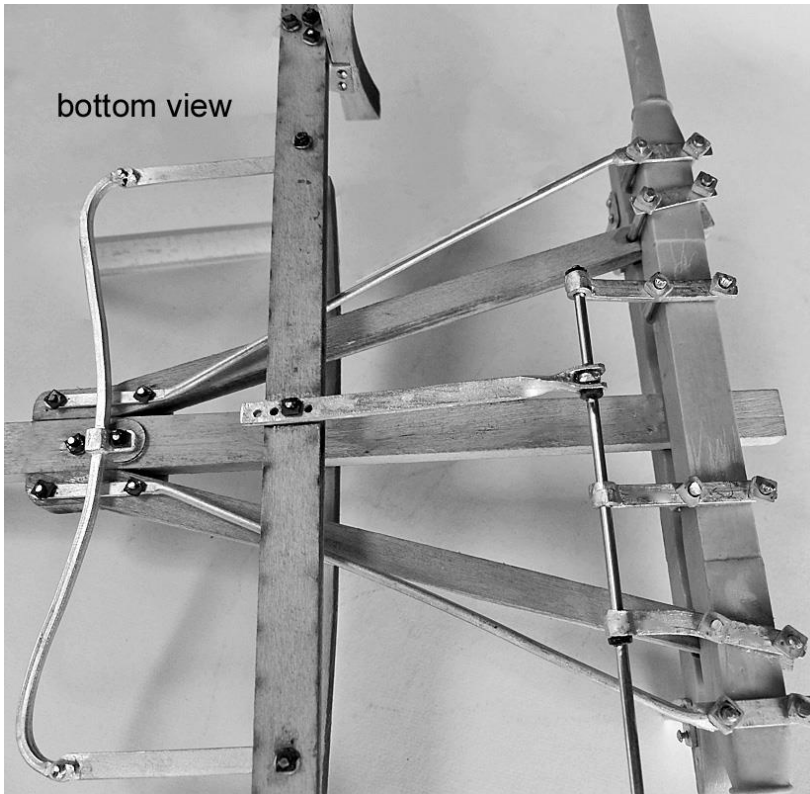

NOTE: the center bracket on the return spring faces up so it will lie flat against the round spring spacer. The eyes in the eyebolts face the tabs on the return spring arm.

In a similar manner attach the other eyebolts to the brake slide. Since there is no cast metal fitting here, a card washer is used on both surfaces of the brake slide. Finish off with gasket nuts.

NOTE: the eyes in the eyebolts affixed to the slide face parallel to the

slide main axis, or 90° to the ones in the brake arm. This is so the split rings do not kink.

Remove the wheels and turn the rear running gear subassembly bottom up. Slide the brake arm subassembly over the coupler and axle braces so the spring bracket hole is over its spacer on the coupler. Secure it with an escutcheon pin inserted from the coupler plate on the other side. Do not use card washers, just a gasket nut over the spring bracket.



Use an escutcheon pin to attach the brake coupler to the actuator, left hanging on the brass rod. Secure the pin with a gasket square nut so that the joints, for now, swing freely. Insert an escutcheon pin through a card washer and then through the center hole in the top side of the of the brake arm and use it to secure the brake coupler to the brake arm through the second hole in the coupler, per the photograph. Coupler and arm may be glued together at a 90° angle.

Slide the actuator on the brass rod so it and the brake coupler are centered over the wagon coupler. Slip the rear wheels back on and adjust the brake spring so the arced surface of the brake shoes leave an approximately 1/8" gap between them and the wheels. Glue the actuator to the brass rod, and, since the brakes are not actually functional, glue the slide to the coupler and wood axle braces. The rest hangs.

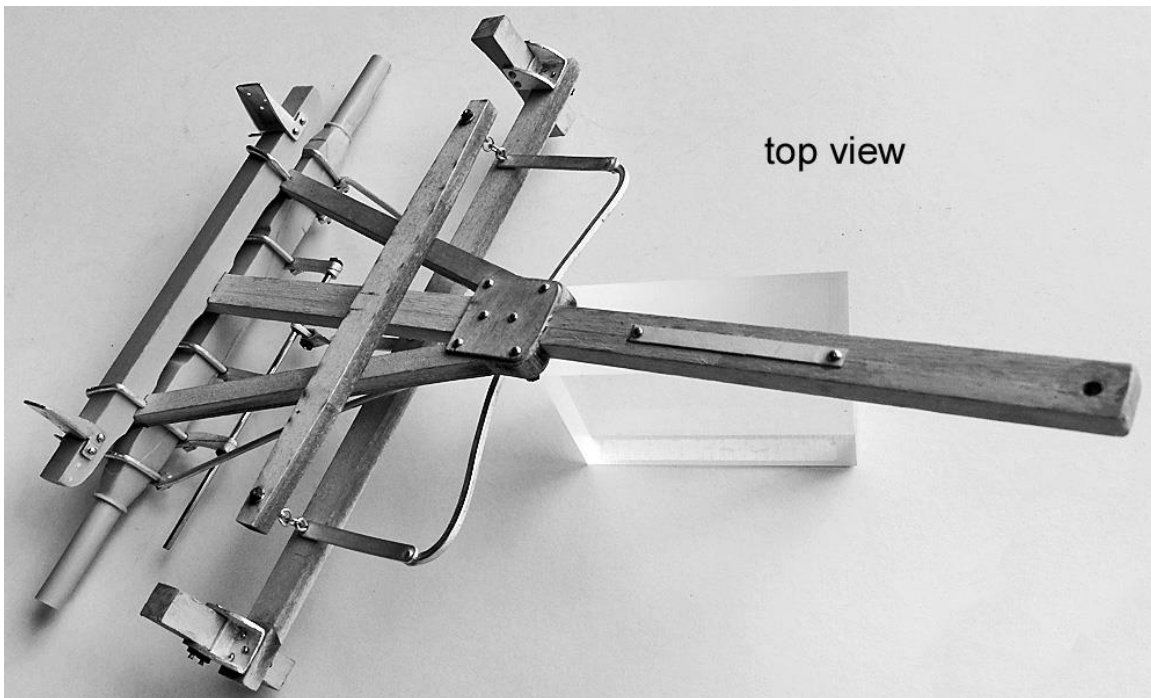

## **WAGON BED**

You should have already assembled the laser-cut front rails and cradles. Drill equally spaced #66 pilot holes for escutcheon pins at the front end of the rails into the front piece, three holes per side. The pins may be cut shorter before insertion. Do not yet insert pins into the top and middle holes on the right side.

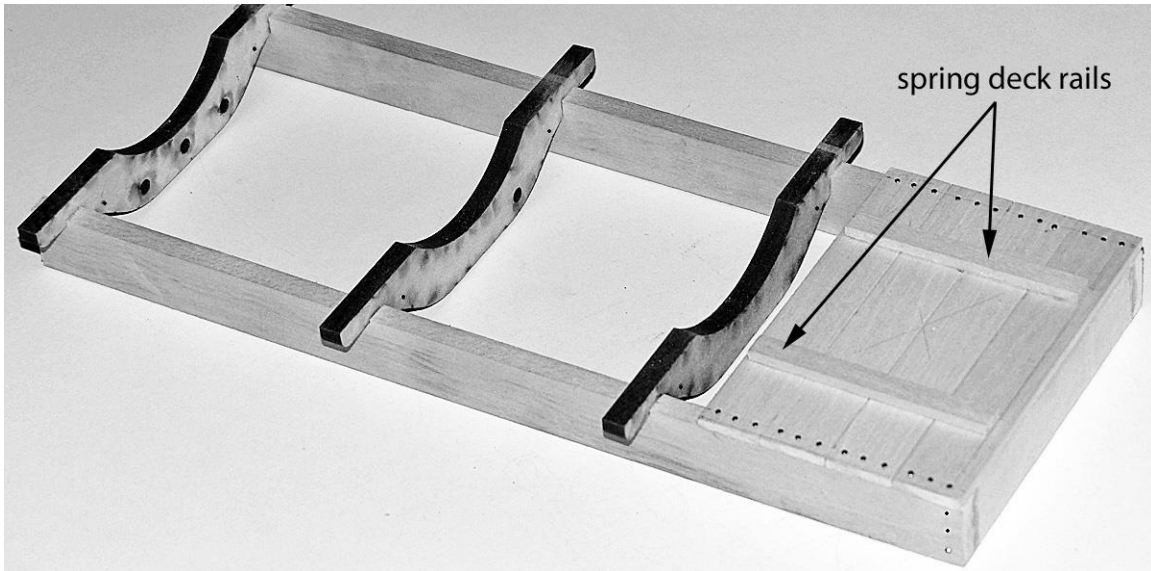

Measure  $2 \frac{3}{8}$ " forward from the rear end of the rails and draw a mark. Unpin one of the bed brackets from the undercarriage, center it on the pencil line, per the following photograph, mark and drill holes for escutcheon pins. Do this on both sides. Re-pin the bed bracket to the undercarriage.

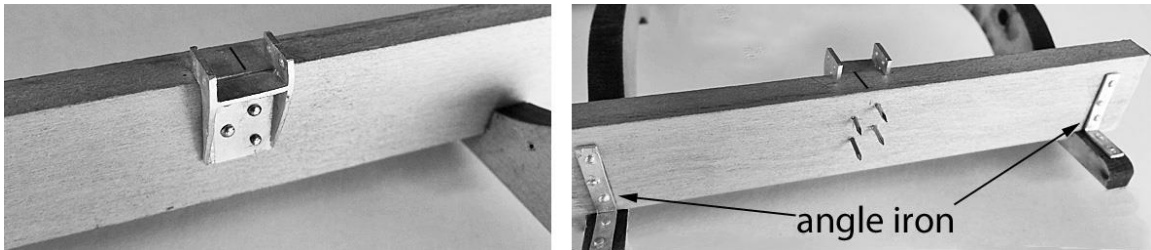

Maneuver the coupler between the front running gear arcs and into the space between the front axle and half chair. Pin the two sections together by inserting the kingpin and pivot chair. Slip on all four wheels. Temporarily pin the bed rails to the rear undercarriage brackets. Where the rails lie against the forward bed brackets, mark the four pin holes on each rail. Unpin the bed and drill the holes.

Plank the deck using laser-cut parts. Make sure the planks are flush with the rail outsides. Drill #74 pilot holes and insert three brass nails into each end of each board.

Make the seat spring deck rails from two  $2 \frac{1}{2}$ " lengths of  $\frac{1}{8}$ " x  $\frac{1}{4}$ " kit lumber. These are glued down spaced 1" on center from the outer edge of the bed rails and equidistant from the deck front and rear. Glue on the six angle irons where the cradle arms extend past the rails.

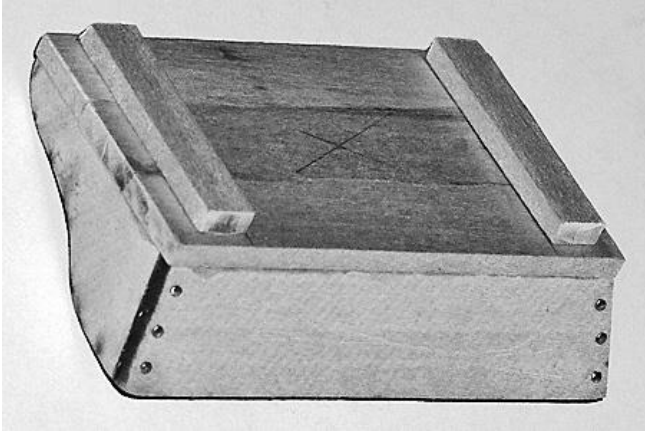

Assemble the seat sides and back, maintaining right angles between them. Because they are angled from the vertical, the bottom edges will not be flat. After reinforcing this with brass nails, per the photograph, carefully sand the bottom flat.

Plank the seat bottom with 2 9/16" lengths of 1/8" x 1/2" kit lumber. Make the spring seat rails from 1

5/8" lengths of 1/8" x 1/4" kit lumber, spaced equidistant front and rear on the seat bottom and aligned with the spring rails on the deck.

Center a seat spring on its deck rail and mark, then drill, holes for escutcheon pins. Repeat the process on the other deck rail, then essentially the same on underside of the seat itself.

"Bolt" the springs to the seat with escutcheon pins slipped through one card washer each on the seat top side and a gasket nut, glued in place, where the pins emerge from the springs. Cut the pins so they slightly protrude through the nuts. "Bolt" this subassembly to the deck rails by inserting pins through the springs then into the wood. Where the pins emerge on the underside, secure them with a card washer and gasket nut each, glued in place. Give a gentle twist to the seat to correct any alignment problem, then apply CA to the springs where they touch wood to lock them in place.

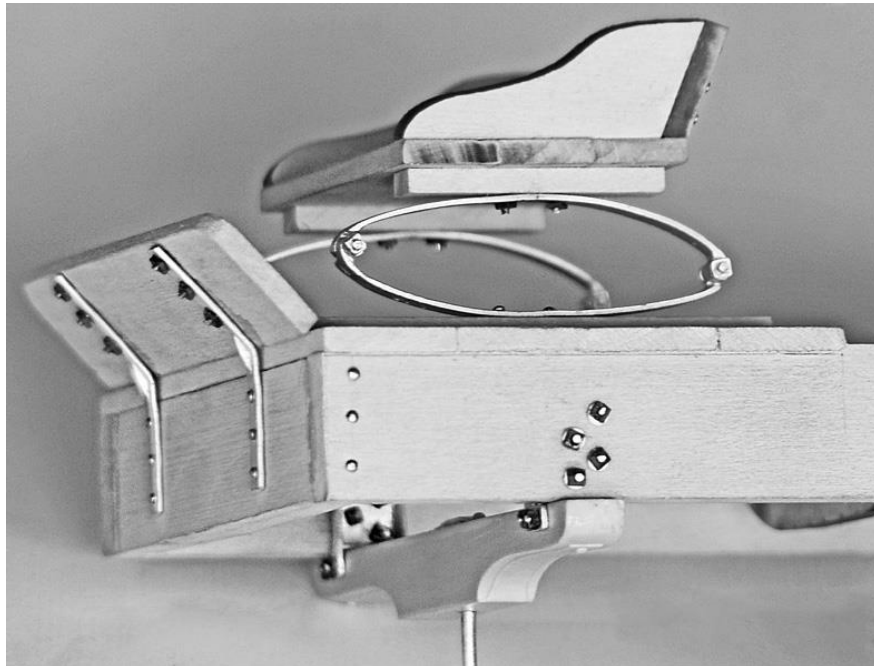

Make the footrest from a 3 1/2" length of 1/8" x 3/4" kit lumber. Radius the top corners only. Locate the footrest brackets 3/4" in from each end of the board and drill as before. "Bolt" the brackets in place with escutcheon pins inserted through a card washer each from the driver's side, secured with a glued on gasket nut where the pin comes through the bracket. Cut the pins to length. Center the footrest at the front of the bed and drill as before. This time, the pins go through the brackets to be secured inside the bed framework with a card washer and gasket nut each.

Remove the pivot chair from the undercarriage and attach it to the front of the bed per the above photograph. NOTE: the escutcheon pins on the right side are positioned from the outside in and on the left from the inside out. As usual use a card washer where each pin penetrates or emerges through wood, not metal. Secure the bed brackets to the pivot chair in the usual manner and cut the excess from the pins.



Place the Geisler brake lever casting ratchet side down. Note the holes in the release handle near the top and in the ratchet pawl at the arced section. Make a small right-angle bend in the end of the 1/32" brass rod. Insert the bent end in either hole, Measure to the other hole and make an identical bend in the brass rod. This will connect the release lever to the pawl. Trim the bent ends so they barely protrude from the other side. Glue in place

Strike a light pencil line from the middle hole at the right front of the wagon bed, parallel to the rail edges. Temporarily pin the ratchet end of the brake lever casting to the middle hole at

the right front of the wagon bed. Where the opposite hole crosses the pencil line mark and drill a #66 hole through the rail for an escutcheon pin. Remove the brake lever casting, then repeat the process for the brake lever guide using the top hole in the wagon bed front. Remove the guide.

With the brass rod to the inside, pin the brake assembly to the rail using a small-hole gasket washer at each hole between the casting and the bed rail. Push the forward pin home and secure the rear pin with a card washer and gasket nut to the inside of the rail. Trim as

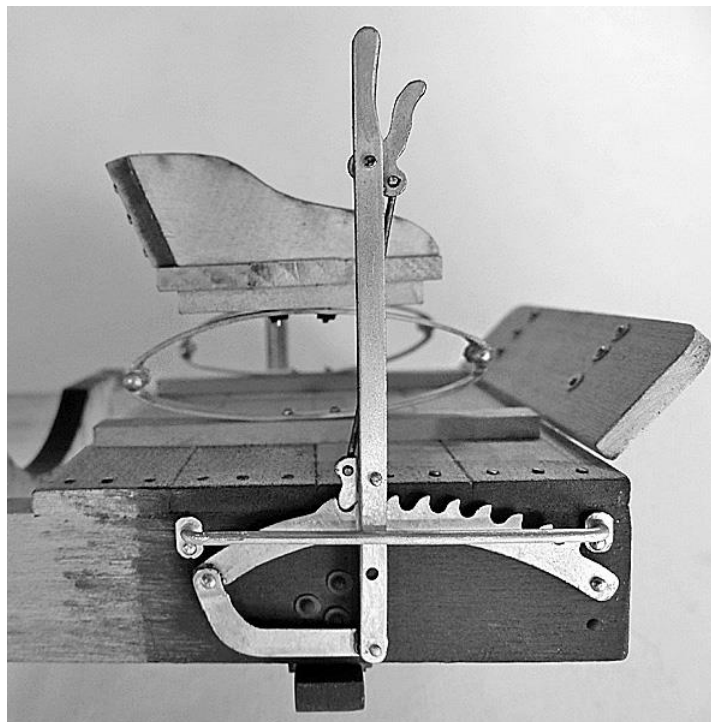

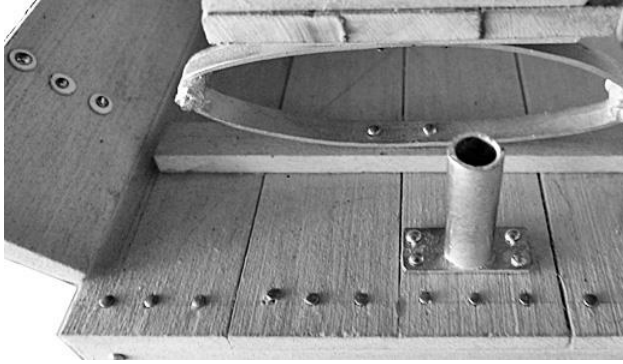

before. Re-install the lever guide in the same manner, including use of small-hole gasket washers.

The driver would use a large market umbrella for shade. Position the umbrella socket on the left side of the deck. Drill through the deck and attach the socket with four each pins, card washers and gasket nuts. Paint the seat

underside black and the rest orange. Paint the rest of the wagon bed subassembly black.

## PANNIERS

The two panniers, or side bins, are assembled into right and left units, with the boxed cutouts to the outside rear, forming fenders for the rear wheels. HINT: The easiest way to assemble the panniers is to tape the parts in place from the outside and then run a bead of diluted wood glue along the inside seams.

Make the panniers and fenders separately, then glue the fenders in place. NOTE: the bottom **A** should be inside the sides and back, so that none of its width and length is sacrificed and that sides **B** and **C** protrude slightly forward beyond the bottom. Back **E** is longer than the door so that the sides butt up against the back. The fender tops sit atop the sides and backs, and these subassemblies are glued atop the pannier bottoms, not within the cutouts.

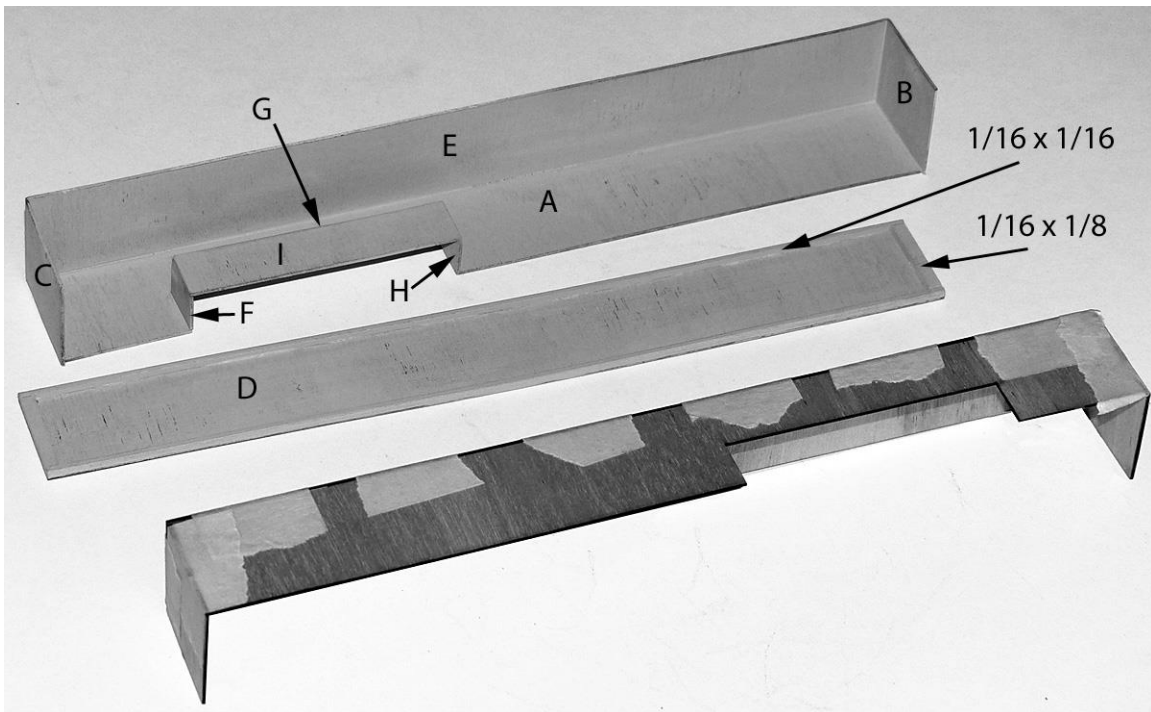



Glue a length of 1/16" x 1/16" kit lumber to the face of door **D** along the top and bottom edges. When dry round over the outside edge of the added strips and fill in between them with short lengths of 1/16" x 1/8" kit lumber (1/8" sides against part **D**).

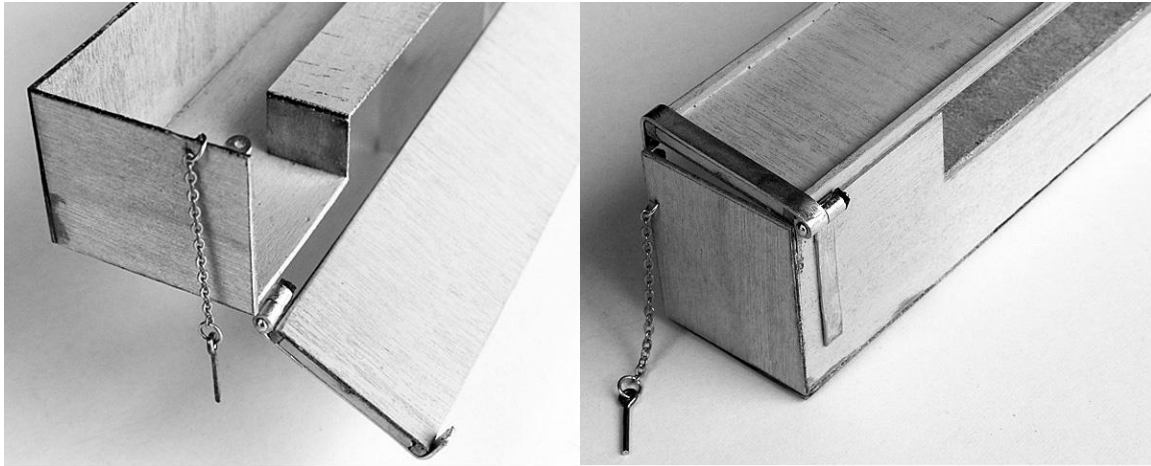

Referring to the above photographs, glue the door hinge halves flush with the edges of the door, on the outside. Escutcheon pin the bottom hinge halves to the door hinge halves to align them and glue in place under **A**. NOTE: the cylinder part of the bottom hinge hangs down. Glue a gasket nut onto the escutcheon pins against the hinge cylinders, then cut the pins so they protrude slightly from the nuts.

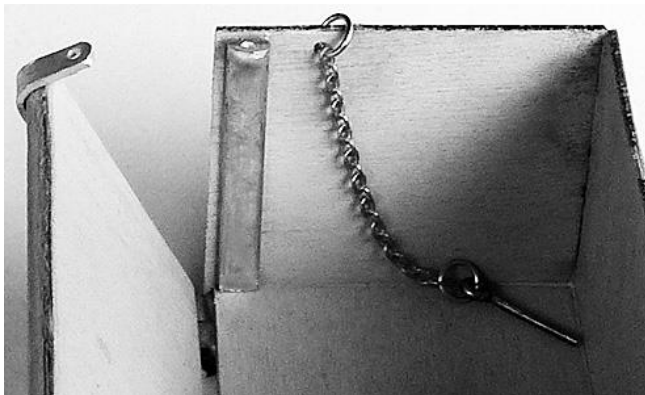

Glue a pin bracket to each end so it aligns with the bottom, NOT the outside edge of the sides. When the door is closed the tab on its hinge should lap over the bracket with the holes aligned.

Paint the panniers orange.

Assemble each retaining pin using an eyebolt, with its point cut off, a one-inch length of fine chain and split rings to affix the chain to the laser-drilled hole in the pannier ends and the pins.

For best display of your finished model we recommend that the right side pannier be kept closed to show off the brake connection. The left pannier can be left with its door hanging open.



## COMBINE WAGON BED, TANK AND RUNNING GEAR

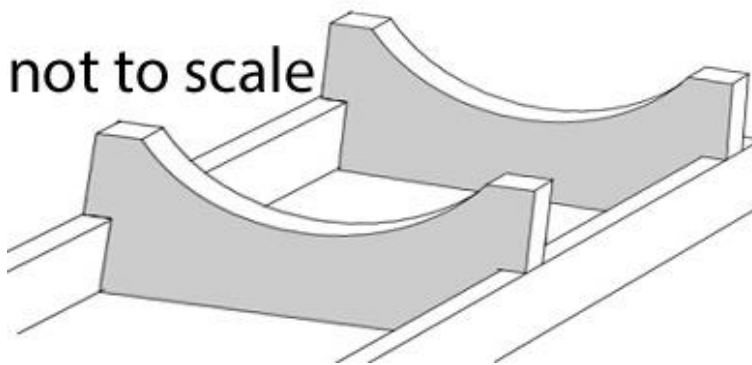

Assemble the construction cradle by gluing two rails made from 3/16" x 5/8" x 12" kit lumber to the rectangular cutouts in the two laser cut cradles. Position one cradle in about 1/2" from one end of the rails. This is the rear. Position the other cradle 7" farther along from the rear

cradle. Use wood glue. **DO NOT CUT THE RAILS.** Leave them extended to the front.

Lay the tank upside down in the construction cradle so the tank is roughly centered between the cradles. Lay the wagon bed subassembly atop the tank so the front end of the tank is against the rear end of the planked deck. The deck and associated parts will hang over the rail extensions. Align the tank centerline with the center hole in the rearmost cradle.

Mark dead center on the bottom of the middle cradle and drill a 3/32" hole straight down through the cradle and the tank. Remove the wagon bed and re-drill the cradle to make a 1/8" diameter clearance hole. Countersink the hole at the cradle bottom, then replace the wagon bed on the tank and fasten with a provided machine screw. Mark and drill a 3/32" hole in the front cradle, through the tank as before. Drill the 1/8" clearance hole through the cradle. **BE CAREFUL NOT TO PENETRATE THE TANK WITH THE CLEARANCE HOLE.** Countersink as before and secure with the other machine screw. If desired, you may putty over the screw heads to hide them.

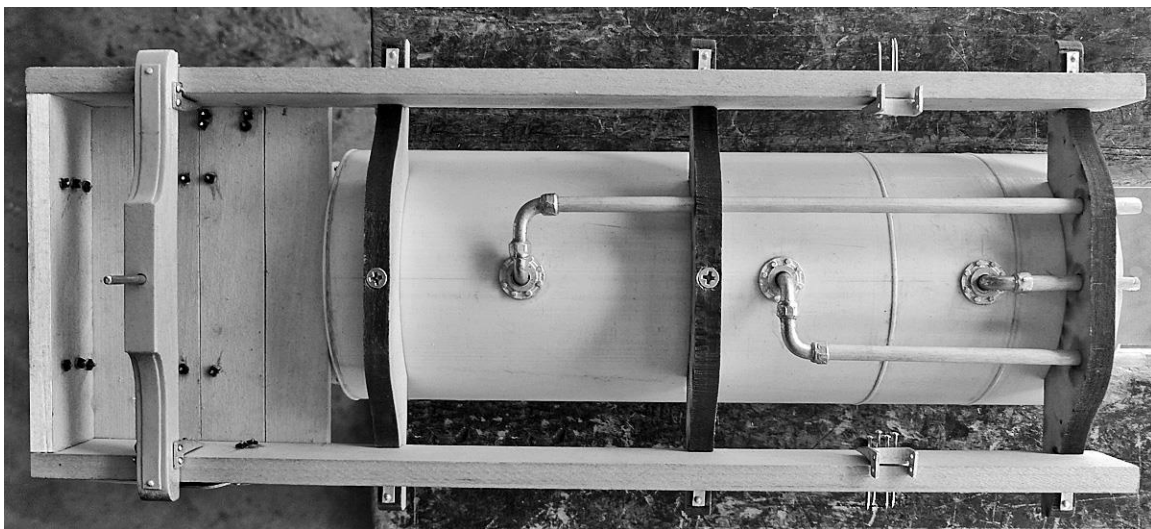

Insert the 5/32" pipe dowels. Measure out 3/8" on each dowel from the outside of the rear tank cradle. (They will measure approximately 5 3/4", 1 3/16" and 3 3/16".) Remove the pipes, paint them orange and glue them in place.

Unpin the rear bed brackets from the chair and loose pin them from the inside out to their respective positions against the bed rails. Turn everything upside down again.

Insert the front of the coupler through the arcs of the steering stabilizers, then between the half chair and the front axle. Work the kingpin into the front half chair and axle. At the same time lay the rear chair into the bed brackets. Pin the rear brackets to the chair.

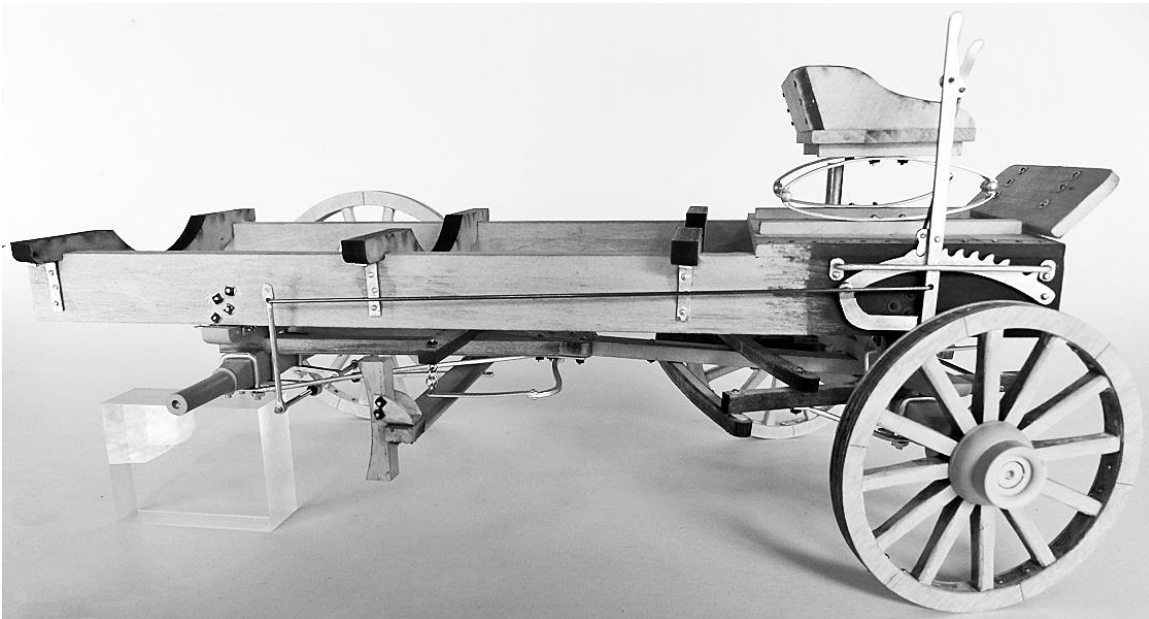

Pull the bed rail pins tight and finish off with a card washer and gasket nut for each escutcheon pin. Pull tight the loose pins holding the bed brackets to the chair and finish off with gasket nuts. Trim off the excess length from all of the escutcheon pins. Slip on the wheels, excepting the right rear. Use whatever fits to support the right rear axle.

Slip the cast brake arm onto the brass rod brake shaft. Connect its lower top hole to the remaining hole in the Geisler brake lever using a length of 3/64" brass rod which you have prepared with a tight right-angle bend in each end. Trim the bent ends so they just protrude through the cast parts they join. Glue the cast brake arm near the end of the brake shaft, then glue in the connecting rod.

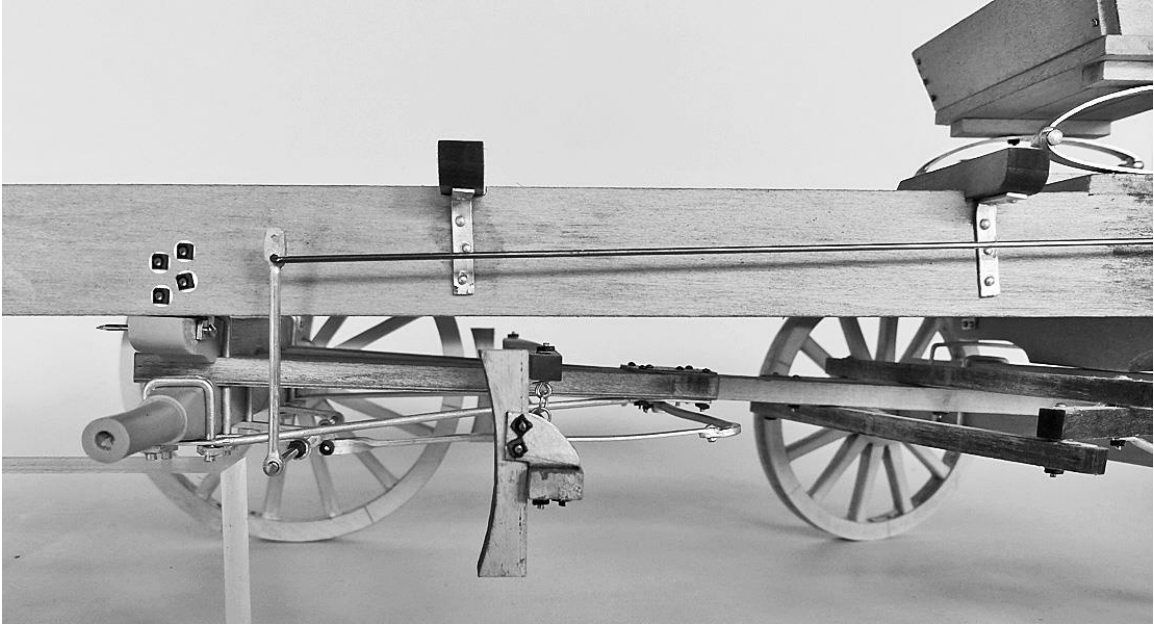

Slip on the remaining wheel and secure the wheels by gluing the pin of the cast wheel hub nuts and washers into the holes at the axle ends. The wheels can be left to turn freely or be glued to the axle to keep your display model from rolling on the shelf.

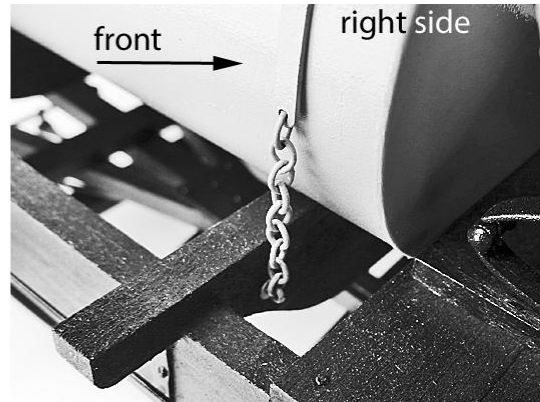
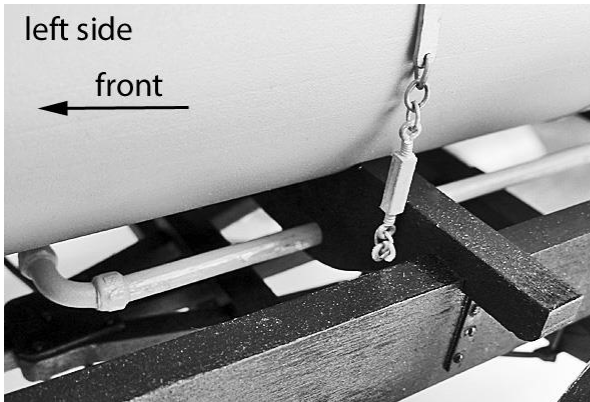

Prepare the three tank straps by first reinforcing the end holes with a drop of CA. Affix two large chain links to one end of each strap, then connect the free end to a turnbuckle using a split ring. The free end of the turnbuckle is attached to an eyebolt by another split ring. This is the left side of the strap. For the right side, attach eight large chain links to the strap end. Use a split ring to affix the other end of each chain to an eyebolt. Paint the strap assemblies orange.



For each strap insert the chain end eyebolt through a card washer and then through the appropriate laser-drilled cradle hole on the right front of the cradle. **MAKE SURE THE RING OF EVERY EYEBOLT IS ORIENTED VERTICALLY AND THERE ARE NO KINKS IN THE CHAINS.** Insert the turnbuckle end through a card washer and then through the appropriate laser-drilled cradle hole on the left front of the cradle. Finish off the attachments with card washers and gasket nuts as usual, trim the nail ends and paint the nuts and washers black.

### **ATTACH THE PANNIERS AND COMPLETE YOUR MODEL**

The right and left panniers also serve as fenders for the rear wheels. Choose a side to begin. Place that side's pannier atop the arms that protrude from the tank cradles. Slide it forward so the rear hinge half on the pannier's underside lies against the rearmost cradle arm. The wheel will lie inside the fender box. Adjust the pannier in or out so the wheel does not rub either the inside of the fender box or the closed door.

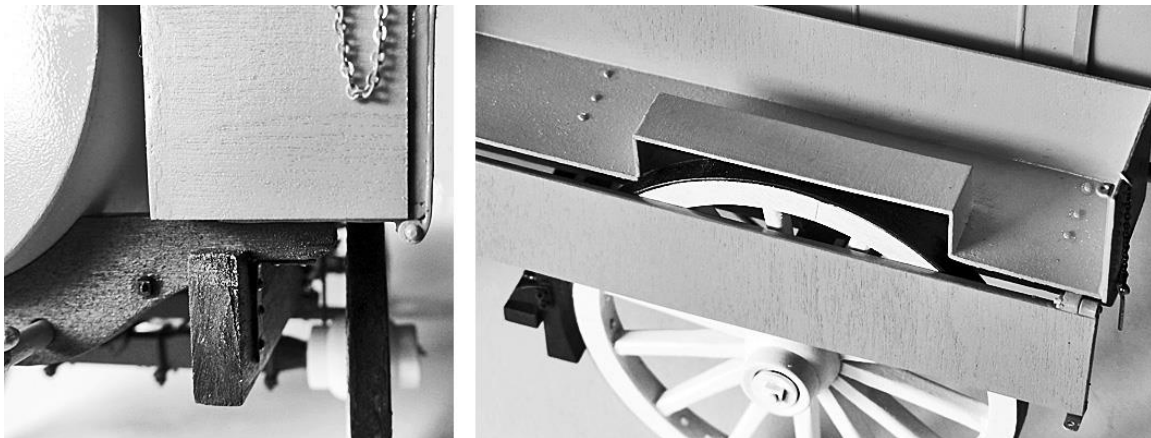

The pannier is secured by three small brass nails into each cradle arm that are spaced outward from the inner back wall at approximately 1/8", 3/8" and 5/8". #74 pilot holes must be drilled through the pannier and into each cradle arm. It is recommended that you then use a #66 drill to make clearance holes in the pannier only. **BE VERY CAREFUL NOT TO DRILL THROUGH THE CRADLE ARMS.** The outer two of each group of

three nails should be slightly trimmed to ensure they do not penetrate through the cradle arms. To avoid breaking the nearly completed model, support it with one hand as you push in the nails with the other using a rigid, non-slip object such as a small file. Repeat the procedure on the other side.

Paint the cast metal gas can handle black, the cast resin can itself orange. Slightly spread the handle arms to fit the parts together, as in the photograph, then gently squeeze the arms tight to the can.



### **APPLYING THE WATER-SLIDE DECALS**

NOTE the spacing of the three segments of the large white company decals. This is the same spacing that is used when applying the decals to the oil tank. Tack down a strip of 3/4" drafting tape - NOT MASKING TAPE - the length of the oil tank with its top edge against the filler domes. This will properly set the vertical position of the company decals and will facilitate aligning the three segments. It is helpful, in getting the spacing right, to pencil tic marks on the tape that correspond to the top notches in the "B," the "D" and the tops of the "66." Even though the company decal has been broken down into three segments, large, thin decals are tricky to handle. Use plenty of water and try to slide them as close to the final position as possible to minimize needed adjustment. After these decals are reasonably dry, paint over them with a decal setting solution to flatten out the wrinkles and snug them down around the tank straps. Repeat for the other side.



The five Phillips 66 logo decals go one centered on the front of the gas can under the spout and one centered on each end panel of the panniers. The gas can decal is simple to apply and center, the ones on the panniers are a bit trickier due to whatever remains of the plywood grain through the paint. As before, follow up with a setting solution. Repeat

applications of setting solution as needed. Finally seal everything with a semi-gloss or satin clear varnish.

