

Building a *Doctor's Buggy* Model

Circa 1800s

MODEL TRAILWAYS KIT NO. MS6003



Technical Characteristics:

Scale 1:12, 1" = 1 foot

Length 8"

Width 5.5"

Height 5"

Kit design, plans, instructions, and prototype model by Bob Crane, 2011

History and Research

You have probably seen a movie or two in which the doctor arrives driving his horse drawn all black buggy with his black medical bag. Our model was designed largely from a drawing published in the trade journal "The Hub" in 1884, as well as a collection of photographs. These buggies were usually of one of two designs. The box bed design had a rectangular box body much like a very small buckboard upon which the seat rested. The phaeton design had a much more elegant shape to the body with a graceful contoured shape. Phaeton is the early 19th-century term for a sporty open carriage drawn by a single horse, typically with four extravagantly large wheels, very lightly sprung, with a minimal body, fast and dangerous. The term is believed to derive from the disastrous ride of mythical Phaeton, son of Helios, who set the earth on fire while attempting to drive the chariot of the sun.

Our model is of the phaeton type, lightly constructed, and designed for a single horse and a single occupant. These buggies were light and fast and could handle terrain that heavier wagons could not. Doctor's would make their rounds and house calls in all kinds of weather and at all hours. In addition to his physicians bag the buggy had storage compartments beneath the seat for additional medical instruments and supplies. Many buggies had a folding leather top that could be raised in inclement weather. We have chosen to not include a top with our model as it would be very difficult to model at our small scale.

Before You Begin

The Doctor's Buggy is an historic and interesting vehicle and makes a splendid model. At 1" = 1' 0" (1:12) scale, it is easy to build and obtain precise detail. Laser-cut parts offer a simple building method. Britannia fittings, and brass photoetch parts, eliminate creating parts from scratch.

Before starting the model, carefully examine the kit and study the plans and this instruction manual. First, determine if all the listed parts are present. Handling them will produce a better understanding of the kit's requirements. Try to visualize how every piece will look on the completed model. Also, determine the building sequence - what must be done first - ahead of time and what can be done simultaneously if you wish. For example, you may want to skip to the end of this manual and begin the wheel construction as you are working on other parts. The instructions will help, but a thorough knowledge of the plans at the outset is essential.

The Plans

Three plan sheets are provided. The plans are done in an isometric format illustrating the construction sequence and identifying the parts and their placement. Sheet 3 shows the layout of the parts on the laser cut boards and identifies the parts by number. It also shows the photo-etched brass sheet and identifies these parts. These drawings are to no particular scale, being illustrative of the construction sequence and sized to fit on the sheet. There are no parts to be made by referring to a full size plan. Some items are drawn to full scale and are so noted on the plan sheets.

Making Allowances along the Way

Try to be exact when following the plans and instructions, but use common sense. Adjustments may be necessary to compensate for small differences in how your model is shaping up. Perhaps a bit of shaving here, a little shim there, a little filler there, etc., will alleviate any annoyances. Use logic and do not fret over exactness. An old saying in the model building craft is that "if it looks right, it is right."

Kit Lumber

Basswood and cherry strips and laser cut sheets of basswood and plywood are supplied in the kit. Sorting the wood in the kit by dimension is a good practice. After selecting and cutting what you need, return the remaining stock to the proper dimension pile. Don't worry about using a piece for one item intended for another. Model Trailways supplies enough extra wood to complete the model before running out. A word about laser cutting: a common misconception is that the parts should punch out of the carrier sheet. This is not so. Laser cut parts are retained in the carrier sheet by small bridges of uncut wood called tabs. Tabs can be oriented parallel to the grain or perpendicular to the grain. It is always better to cut through these tabs rather than try to punch out the parts by breaking the tabs. This is particularly true of laser cut plywood. Plywood is much more difficult to laser cut than basswood. You may have to cut through not only the tabs but portions of the part outline that did not cut completely through the sheet. Turn the sheet over and cut from the backside to release the part without damage.

Britannia Metal Fittings

There are only a few Britannia fittings in this kit: the front and rear axles, the front and rear body hangers, the front and rear spring assemblies, the step struts, and the mud splash frame. First, remove any mold joint flash with a #11 hobby blade, then file or sand with fine sandpaper. Second, wash fittings in dishwashing liquid and warm water to remove traces of mold release agent and the body oils your fingers deposit. Allow the parts to dry thoroughly before applying primer and painting. For applications where it is required to glue a Britannia part to wood, it is a good idea to rough up the Britannia gluing surface with sandpaper.

Wheel Hubs and Axles

The wheel hubs in the kit are precision machined from aluminum. The axles are cast Britannia metal. It is important to check the fit of the hubs on the axles at the outset before beginning the kit. Being cast, the axles will likely have a tiny bit of flash preventing a running fit on the hubs. Use a sanding stick to work the axles until the hubs fit and run freely. The axle can be easily bent, so work carefully. If you should happen to bend an axle, it can be straightened by comparing it to the full size axle views on plan sheet 1.

Working with Brass

The brass in your kit is a photo-etched sheet. Refer to sheet 3 to identify the parts by number and name. A few of these parts are designed to be formed into shape by bending. In most cases, the bend lines are etched into the part making correct bending easy. The bend lines are etched halfway through the sheet and are easily identified. In most cases, it is desirable to bend the parts so that the bend lines are to the outside of the bend. This is not always possible, so use common sense and judgment.

Glues

White or woodworker's glue in yellow or tan will suffice for most of the model. Five-minute epoxy provides extra strength for some cases. Super glues, such as Jet, Flash, or Zap, produce quick adhesion. For most applications, the medium viscosity, gap-filling variety is best. For some applications the gel type works best. The thin type is recommended for filling a narrow crack and wicking into laminate joints. We will make recommendations as to what glue type to use throughout the construction process. We will refer to these super glues as CA (cyanoacrylate).

A word about gluing laser cut parts. Laser cutting burns through the wood and leaves a charred surface. This charred surface does not make good glue joints. It is recommended to lightly sand or scrape away the loose char before gluing. It is not necessary to remove all the char, just what comes off with light sanding or scraping. In some cases simply scraping with a no. 11 blade is sufficient.

Clamps

Clamps are an essential part of the model building experience. In the full size boat building arena it is often said, "a boat builder cannot have too many clamps." This is true of model building also. There are so many situations in the course of building a model that require a particular type of clamp. The photo below shows a typical collection of clamps that are useful in model building.



Building the Front Axle Assembly

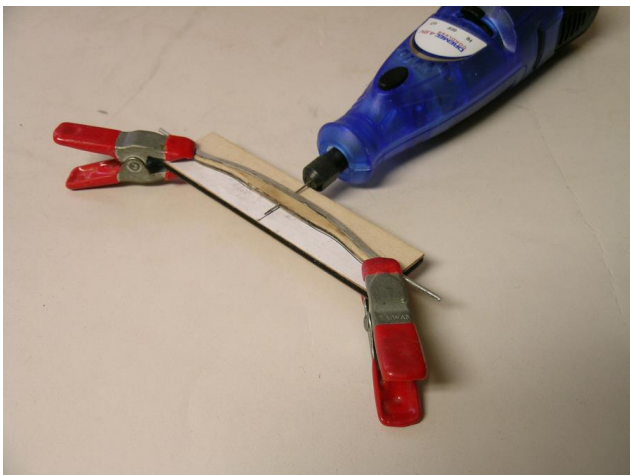

Photo 1: Drilling the front axle

Refer to DETAIL1-1 to familiarize yourself with the front axle and carriage construction. Note that the carriage is joined to the axle with a king bolt, which passes up through the axle, axle cap, the head block and the spring. Separating the axle and carriage is the fifth wheel. Thus, the axle and carriage can rotate with respect to each other with the fifth wheel providing lateral support.

Note that the 1/32" dia. kingbolt passes through the front axle and the axle cap. Being only 3/32" thick, care must be taken when drilling the hole for the kingbolt to keep it centered and directed perpendicularly. For this reason, we have provided a jig assembly that will aid in achieving good results. Refer to DETAIL 1-3.

Locate the 3/32" plywood jig base, the paper axle drill jig pattern on the pattern sheet, and the 1/32 plywood drill jig part as shown. Assemble and glue these parts as shown to complete the drill jig. Drill the cast axle first. Align the axle with the jig and clamp into place. Laying the drill bit on the jig aligned with the laser etched line will aid in achieving a centered hole properly directed along the lines on the jig. If your hole emerges slightly off, it can be wallowed a bit so that the kingbolt can be properly aligned.

Prepare the front axle cap for gluing by removing the laser char. It is a good idea to roughen the gluing surface of the cast axle a bit with sandpaper. Glue the axle cap to the axle with epoxy glue. Place this assembly back in the jig and complete drilling the king pin hole through the axle cap. A precautionary measure is to drill from both directions to ensure that the hole is centered in the axle cap. Refer to Photo 1. Round over the outboard ends of the axle cap as shown.

Refer to DETAIL 1-4. Locate axle clips B1 and B2. These are parts that simulate an axle clip as is commonly found on vehicles of the horse drawn era. DETAIL 1-4 illustrates a typical full scale axle clip. Bend these to shape and to fit the axle. Note that there are two small notches in the center of these brass parts. This is to indicate the center line to assist you in bending these parts. If you have a pair of chain nose pliers (the ones with round tapered jaws), this is easy. You can also use a 3/32" dia. drill bit or rod to aid in shaping these parts. Use the full size view in DETAIL 1-1 to mark the location of the axle clips on the axle assembly. Glue the clips to the axle assembly with CA gel. Glue 4 parts B3 to the clips as shown.

Threaded nuts in the era of our buggy were of the square type. Actual square nuts to our model scale are not available. Model Trailways laser cuts simulate square nuts from a compressed gasket material. These are found on laser cut board DB-6. You may find that the center holes are not cut completely through. It is best to hold them down and run a #67 drill through them to clear the hole. Apply the nuts to the axle clips with CA glue. You may want to trim the protruding brass a bit for appearance.

Front axle rotation relative to the carriage is supported by a fifth wheel assembly. This circular assembly provided lateral support for the front axle as it rotated. Locate part A2, lower fifth wheel. Do not confuse this part with A4, upper fifth wheel. Note that a portion of the fifth wheel part is to be cut away after assembly. Glue part A2 to the front axle as shown. Important: ensure that part A2 is perpendicular to the axle assembly. Then dry carve away the portion between the laser etched lines. This is to allow clearance for the U-bolts.



Photo 2: Front axle assembly

TIP: It often occurs in modeling work that one part needs to be glued to another at a right angle (perpendicular). A handy small square for this is made by simply snipping off a corner of a common note card or similar. It can be made to any appropriate size for your use.

The iron fifth wheel was held to the axle assembly by iron rods welded to the fifth wheel. We simulate these by gluing lengths of 1/32" dia. brass rod to the axle assembly and finishing with parts B3 and square nuts as shown. If you have difficulty fitting parts B3 due to the thickness of the axle cap, you can

elongate these holes by running a drill bit in them with sideways pressure. At this point the front axle assembly may be finish painted if desired.

Building the Rear Axle Assembly

Refer to DETAIL 1-5. Prepare part A6, rear axle cap, for gluing. Roughen the gluing surface of the cast metal rear axle with a sanding stick. Glue the cap to the axle with epoxy glue. Round over the outboard ends of the cap as shown. Refer to DETAIL 1-2 to locate and mark the locations of the axle clips. Form axle clips B5, B6, and B7 to fit the axle and glue with CA gel or epoxy. Finish axle clips B6 and B7 with parts B3 and square nuts. Note that clip B5 does not take a part B3 as part B8, reach brace, will later attach to part B5.

Epoxy the rear spring assembly to the axle cap ensuring the spring is properly centered. Form 2 U-bolts from 20 gauge brass wire and glue in place as shown. Finish with 2 parts B4 and square nuts. Epoxy part A6, rear spring bar, to the

spring as shown. Locate and drill through the bar and spring with a #67 drill. As you did when drilling the front axle, it is best to lay the assembly flat and drill horizontally to help you keep the hole centered. Cut two lengths of 1/32" dia. brass rod and insert, finishing with square nuts. Trim the brass rod to an appropriate length. This completes the rear axle assembly. The assembly may be painted with the exception of the axle rods and the areas on the spring bar where the body assembly will later attach.

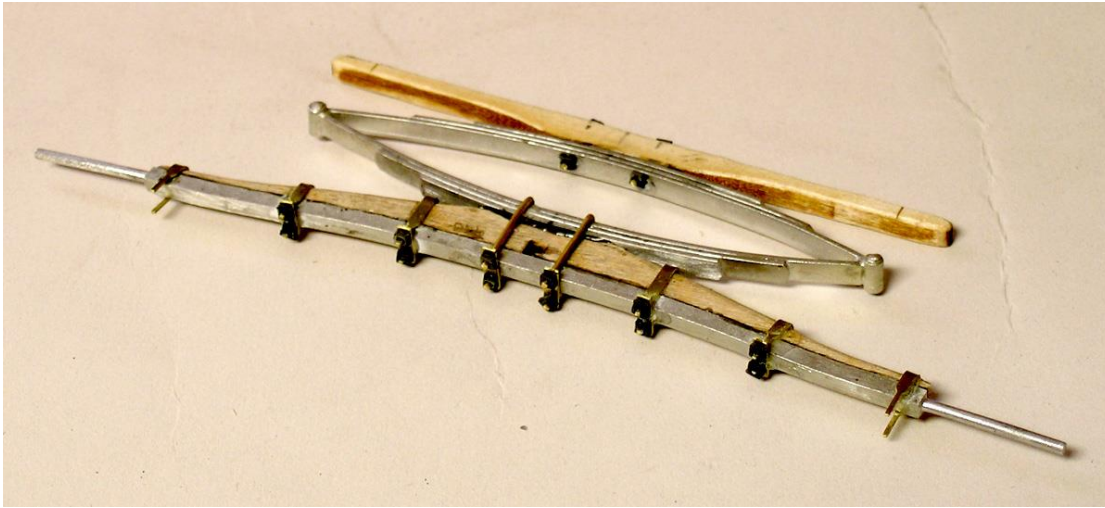

Photo 3: Rear axle assembly

Building the Undercarriage Assembly

The front axle and rear axle are connected to each other by the king pin, the head block, and the reach, which extends from the head block to the rear axle assembly. Our particular model sports a reach which has an elegant S-curve bend. Coach makers of the day were quite skilled at steam bending wood. In fact, the axle caps may well have been steam bent to conform to the shapes of the steel axles. For our model, we will steam bend the reach to shape.



Photo 4: Forming the reach

Locate the bending jig on laser cut board DB-3. The material for the reach in your kit is 3/32" square cherry. You can recognize it by its distinctive color. Cherry more readily steam bends than basswood and is stronger. Snip off a piece of cherry about 6" long. This will be over long for later trimming. Refer to photo 4. Gather suitable clamps as shown. Use a suitable sauce pan and your kitchen stove to boil water. Place the cherry in the boiling water for about 10 minutes. Remove with tongs or tweezers and quickly place on the bending jig and gently bend to shape, securing with clamps. Let both ends of the reach extend beyond the jig. Let this dry, preferably overnight. If you are not satisfied with your first attempt, there is enough material for several tries. This is really much simpler than you may imagine. Note the finished reach in the photo. Mark and trim the ends to the

length dictated by the jig. Give the reach a bit of sanding to smooth the grain raised by the soaking.

Refer to DETAIL 1-6. Locate part A3, the head block. Drill the #67 holes as shown. Again, it is best to drill horizontally for alignment and centering. The outboard hole locations are indicated by engraved lines on the head block. Fit and prepare the head block to receive the reach. It may take a bit of filing for a good and fair fit. Glue the reach into the head block slot, ensuring that the head block is square and perpendicular to the reach. Be sure you have the correct end of the reach before gluing. When dry, complete the drilled hole through the reach. This is the hole for the kingpin. Locate the top half of the fifth wheel, part A4. Glue to the head block and reach as shown. Cut away the shaded portion as shown. Snip off two lengths of 1/32" dia. brass rod and insert as shown. Finish with two square nuts. Trim the brass to an appropriate length.

Epoxy glue the spring assembly to the head block, being careful to keep things centered and square. Finish drill the hole for the king pin through the spring. Again, this is best done horizontally keeping the hole centered as it passes through the spring. Form two U-bolts from 20 gauge brass wire and glue to the head block and spring. Finish with two parts B4 and square nuts. Epoxy glue the front spring bar, part A7, to the spring. Mark the locations and drill two holes for 1/32" dia. brass rod simulated bolts securing the spring bar to the spring as shown. Finish with four square nuts and trim the brass to an appropriate length. This finishes the fore end of the carriage assembly.



Photo 5: Carriage assembly fore end

Refer to DETAIL 1-7. Fit the rear of the reach into the rear axle assembly. Using the undercarriage assembly alignment guide printed on pattern sheet 2, epoxy the reach into the axle assembly. Assure that all is square and that the axle assembly is parallel to the carriage fore end assembly. You may have to use small triangles and some shims to achieve the desired alignment.

The front axle assembly may now be attached to the carriage fore end with the king pin and square nuts. Cut an overly long piece of 1/32" dia. brass rod for the king pin. Glue a square nut to one end and let dry. This will be the bottom nut of the king pin. Pass the pin through the front axle assembly and through the fore end assembly. Cut a small rectangular piece of

waxed paper and drill a hole in it for the king pin. Place this over the king pin so as to not glue the pin to the spring. Place a square nut on the king pin and glue to the pin. Trim the brass pin to an appropriate length for appearance.

Refer to DETAIL 1-8. Add 2 parts B8, the reach braces as shown. Shape the reach braces by first applying a 90 degree twist to the brace and then forming the fore end to fit to the reach as shown. These parts add a great deal of stiffness and strength to the undercarriage. The reach braces are of photo-etched brass for this kit. The real braces would have been welded up from iron round bar and flats. If you are experienced and proficient at fabricating brass parts by soldering, you may want to build these parts from round brass rod and solder on the flat parts cut from parts B8. Use a 3/64" dia. brass rod (not supplied).

Refer to DETAILS 1-9 and 1-10. Shape and add parts B9 and B10. Part B9 serves to support the rear end of the fifth wheel assembly and part B10 stiffens the reach and serves as a keeper for the upper king pin square nut. This completes the undercarriage assembly.

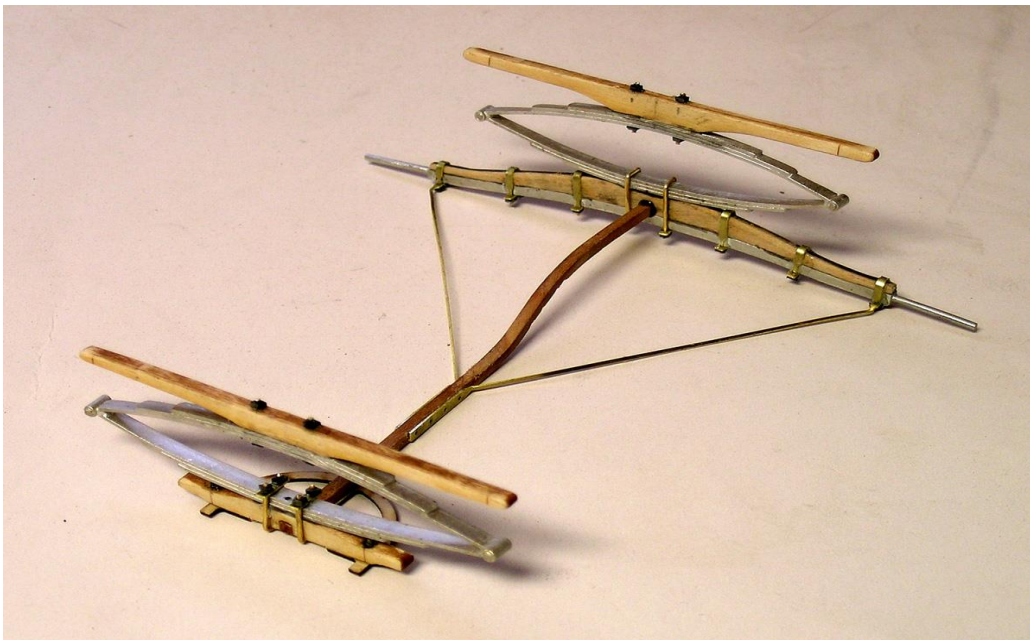

Photo 6: Completed undercarriage assembly

Building the Buggy Body

Refer to DETAIL 2-1. Locate parts C1 and C2. The body sides are laminated from basswood and plywood for strength. Glue one part C1 to C2 with part C2 1/16" basswood to the inside. **IMPORTANT:** be sure to make one left side and one right side. This puts the plywood to the outside, which is easier to finish.

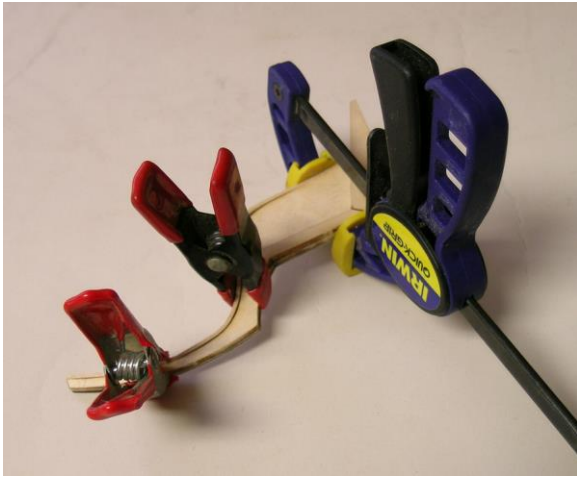

Photo 7: Forming the upper cap strip

The sides of the body will receive cap strips around the edges. These cap strips are from 1/32" x 1/8" basswood. The severe bends in the upper cap strip will require hot/wet bending to achieve the shape required. The time to do that is now. Refer to photo 7. Snip off a piece of 1/32" x 1/8" basswood. Using a suitable container, insert the wood strip into boiling water for about 5 minutes. Remove and quickly bend it to conform to the shape of the body side as shown. Allow the ends to be overlong for later trimming. Clamp in place and let dry, preferably overnight. Make two of these pre-formed cap strips. The cap strips can be seen in photo 9.

Assemble parts C3 and C4 to the sides as shown in DETAIL 2-2. Note that these parts both locate at the bottom aft corner. Glue part C6 to part C3. The sides are now ready to assemble.

Glue part C5 to one of the sides and let dry as in photo 8. Use a square as shown to ensure that C5 is square to the side.



Photo 8: Beginning assembly

Refer to DETAIL 2-3. Note that the left body side is not shown for clarity. Assemble parts C7 and C8 joining the two sides, again checking for square. When dry, add part C9 the storage compartment bottom. This will add a good deal of strength to the assembly. Add part C11 and carve and sand to conform to the shape of the sides as shown.

Refer to DETAIL 2-4. Add bottom parts C12, C13, C14, and C15. Trim and sand these parts flush with the body sides. On board DB-5, you will find a strip labeled "filler strip". Use this to fill in the gaps as shown to complete the 1/64" ply bottom covering of the sides.

Refer to DETAIL 2-5. Apply the pre-formed upper cap strips. Note that the cap strips, both upper and lower, project beyond the body sides by 1/32". See the section drawing. Trim the forward ends flush but leave the aft end long for now. Apply the bottom cap strips as shown. When the aft-most strip has been fitted under the upper cap strip, the upper strip may be trimmed.

Refer to DETAIL 2-6. Fit a 1/32" x 18" cap strip across the front of the assembly as shown. Shape the drawer handles, parts B11, and glue to the drawer fronts, parts C10. Apply the drawer fronts as shown. Locate the front and rear body hanger castings. Prepare these by lightly sanding the gluing surfaces and drilling a few holes as shown. This will aid the glue adhesion. It is recommended that these be applied using a CA gel.

Refer to DETAIL 2-8. Shape and add the cast hand grips using CA gel. Make up the mud splash frame landing blocks as shown. Sand and carve these flush with the upper cap strip. Make up the wheel stops from scrap 1/64" plywood. Note that this thin plywood is easily cut with scissors.

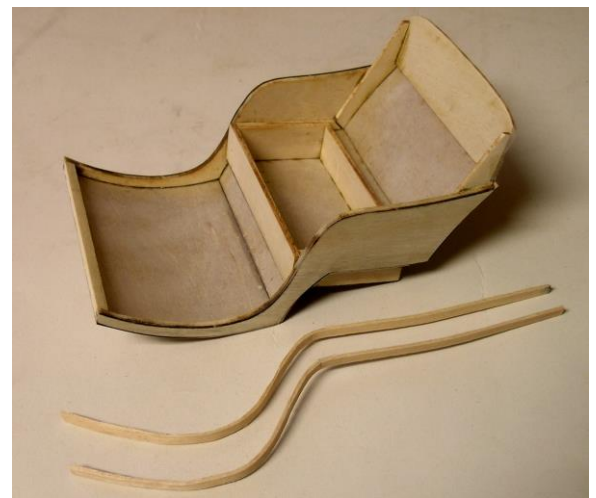

Photo 9: Completed body ready for cap strips

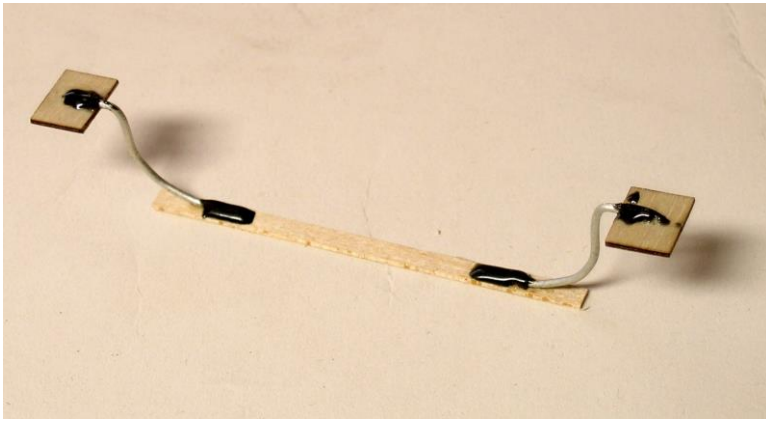

Photo 10: Step strut assembly

Cut a strip of 1/32" x 1/8" basswood to serve as the mounting for the step struts. Glue the struts to the strip and the steps to the strut using CA gel. The steps are parts C21. For added insurance, it is a good idea to overcoat all of these joints with epoxy as shown in photo 10. Glue this assembly to the bottom of the body approximately as shown in the side view on sheet 2. Add the two pieces of 1/32" x 1/8" trim as shown in the rear view.

This completes the body structure. At this point the body can be finish painted with the exception of those surfaces which will later receive glue - the seats and side panels, the mud splash frame landing blocks, the floor, and the underside of the body hanger ends.

Carve and sand the seat cushion parts C18 and C19 to the rounded shape as indicated in DETAIL 2-7. Glue these parts to the seat bottom, part C16, and the seat back, part C17. Note that the seat bottom parts C18 do not quite reach the back of part C16. This is to provide clearance for the seat back to locate properly. Also carve and sand the side cushions to shape. Test fit the seat bottom, seat back, and side cushions to the body and make any necessary adjustments. The seats may now be finished. There are various textured spray paints on the market which can make your seats look very much like fabric. The prototype parts were finished in this manner. They were sprayed with a textured paint of a neutral color and then given finish coats of the desired color.

Note in photo 11, the floor mat has also been pre-painted. The floor mat pattern is on the supplied pattern sheet. You may want to transfer this pattern to card stock, although the prototype model used bond paper as supplied, with good results. These parts may now be glued to the body.

Locate the mud splash frame casting. On one side of the landing pads, there are indentations for starting a drill. Drill two #67 holes in each pad as shown. Refer to the side view on plan sheet 2. Note that there is a gentle curve to the frame at the top. Make this bend now. Cut out the mud splash cover from the pattern sheet. Fit the pattern to the frame by bending the tabs around the frame and gluing on the back side. If you have trouble fitting the bond paper pattern, you may want to transfer the pattern to a less stiff paper, such as thin parchment paper used for cooking. This paper is available at most grocery stores. Paint the mud splash with the exception of the bottom of the landing pads.

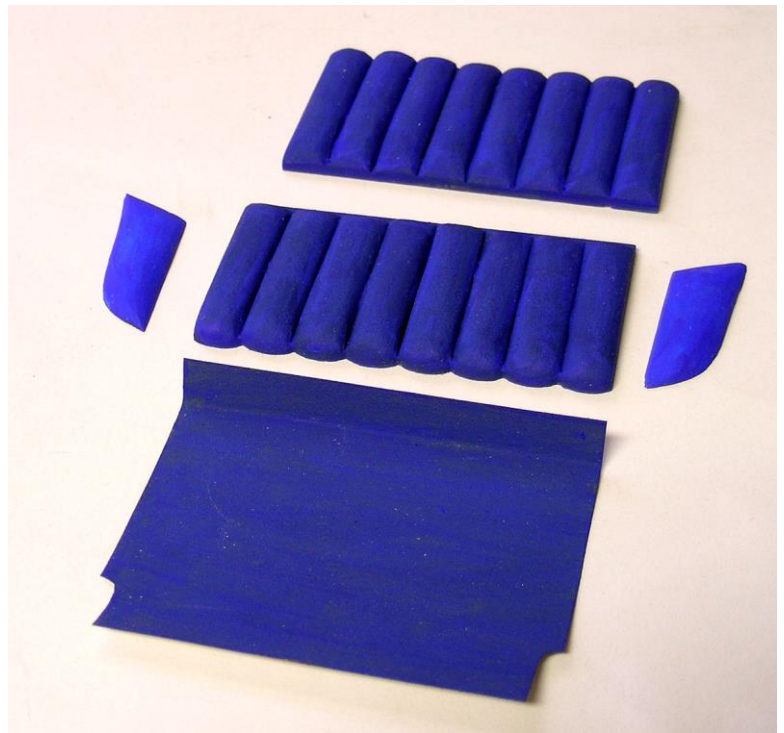
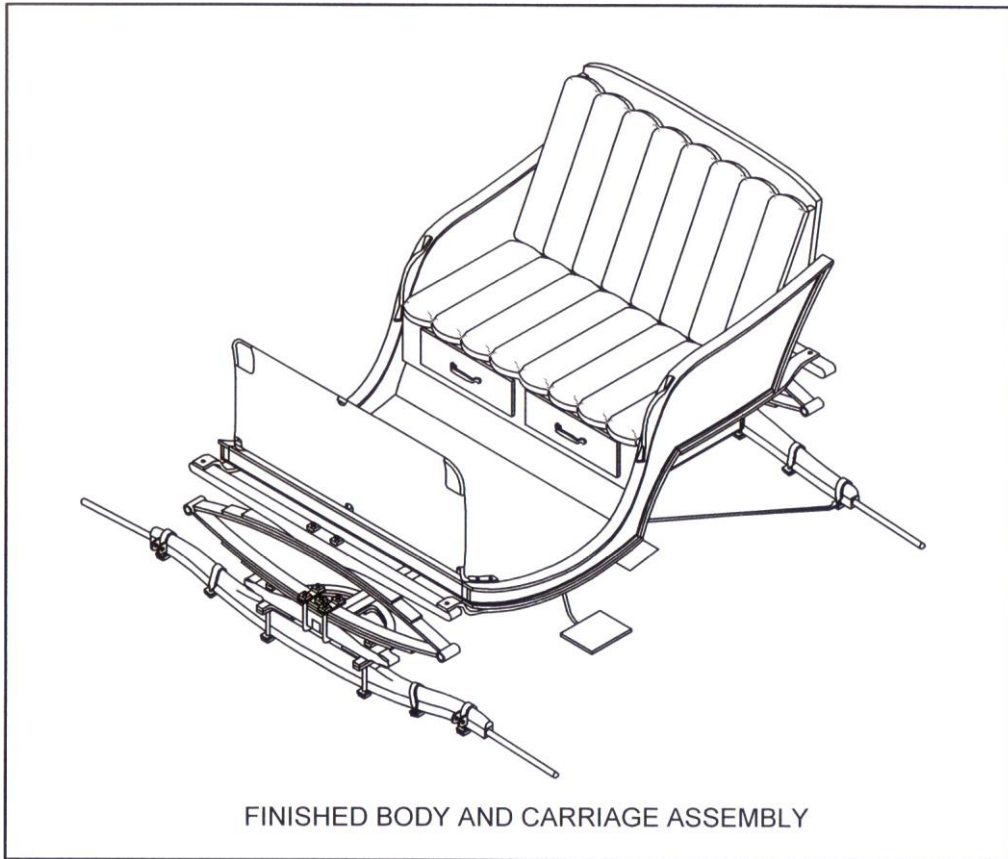

Photo 11: Seats, side cushions, and floor mat

Make the appropriate bend in the landing pads and fit to the body as shown. Glue in place with CA gel. For added security, drill through the pads with a #67 drill to a shallow depth. Cut off brass pins to a short length and insert into the holes. These holes can be very shallow. Touch up any needed spots and we are finished with the body. It is now ready to be attached to the under carriage.

Locate the body assembly on the undercarriage and make any necessary adjustments to the body hangers. Note that the body hangers are easily bent to assure a fair and proper location on the front and rear spring bars. Clamp the body hangers to the spring bars on one side and glue the other side with CA gel. Then, repeat for the other side. Carefully drill #67 holes through the body hangers and spring bars for brass pins. Be sure to adequately support the spring bars when drilling. At the rear, these holes will have to be drilled at a slight angle to clear the body structure. Insert brass pins and cut off the excess. Secure the pins with a bit of thin CA glue. Address any areas requiring paint touchup.



FINISHED BODY AND CARRIAGE ASSEMBLY

Building the Wheels

Refer to the wheel building sequence on plan sheet 2 and photo 12. Get out the wheels and wheel assembly jig from the plywood sheet DB-2. As noted before, do not try to punch these parts out of the sheet, but cut where necessary from the back side until the wheels are easily removed. First it is necessary to add spacer blocks to both sides of the jig as shown.



Photo 12: Wheel assembly jig

Cut out the paper wheel and spoke patterns from the pattern sheet. Carefully cut out the center holes. Glue one pattern to each side of the jig, using a wheel hub to center and align the pattern with the center hole. Note that the outboard end of the hub goes down. The outboard end is the end with the recess. Use only a few spots of carpenter's glue or similar to avoid wrinkling and distorting the pattern.

Locate a wheel on the pattern. You may clamp the wheel in place, or better, drill four small brass nails to hold the wheel to the pattern. These holes may be filled later. Begin fitting spokes into the hub and securing them to hub and wheel with CA gel. Work across the wheel rather than inserting adjacent spokes. Constantly check to be sure the hub is squarely seated in the center hole, lest you end up with a wobbly wheel. Note the scrap 1/64" plywood spacers in the photo. These center the spokes to the wheel. When all spokes have been installed and the glue has set, remove the wheel from the jig.

It was found during the building of the prototype that it is easier to shape the spokes right on the wheel rather than shaping each individual spoke before assembly. Sand away the laser tabs and some of the char and lightly round the edges of the spokes. Finish paint each wheel and apply the tires. The tires are the laser cut strips found on DB-6. If you wish to have your tires exhibit a metallic hue, they can be pre-painted silver before removing them from the laser cut sheet. To apply the tires, spot glue them using CA gel, working around the wheel a few inches at a time. Trim the end to meet the starting point.

The wheels are secured to the axles with square nuts. The axle nuts are the larger ones on sheet DB-6. In order to achieve a scale thickness, two nuts are glued together. Use a piece of 1/16" dia. rod or a 1/16" dia. drill bit to help align the nuts when gluing them together. Secure the nuts to the axle with a bit of CA glue taking care not to glue the hub to the axle with excess glue.

You may find that your axles have been bent a bit during construction. The angle of the wheels is easily adjusted by bending each wheel to its proper orientation for display. You will notice that there is a dish or cone shape to the wheels. This is the way wheels were constructed. This achieves a truss effect making the wheel much stronger. Axles were canted downward so as to bring each spoke plumb to the ground as the wheel rotates, as in the illustration below.

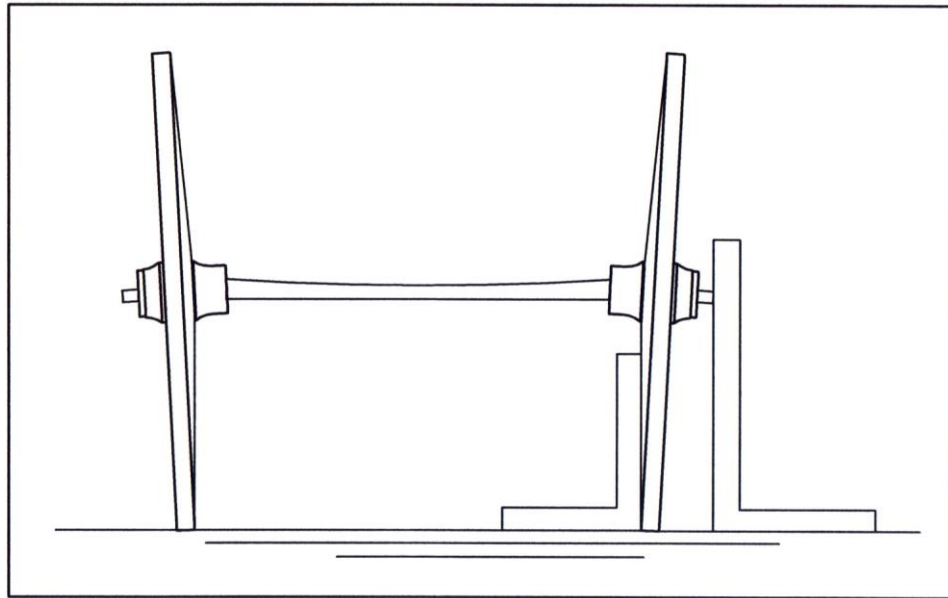

That's it, you are finished. Step back and admire your work and be prepared for compliments from your family and friends.