

INSTRUCTION MANUAL

Rattlesnake

MASSACHUSETTS PRIVATEER

Technical Characteristics

Scale: $3/16'' = 1' 0''$ (1: 64)

Overall Length: 28''

Overall Width: 9''

Overall Height: 18''

Hull Width: 4-1/4''

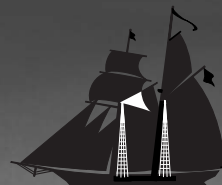
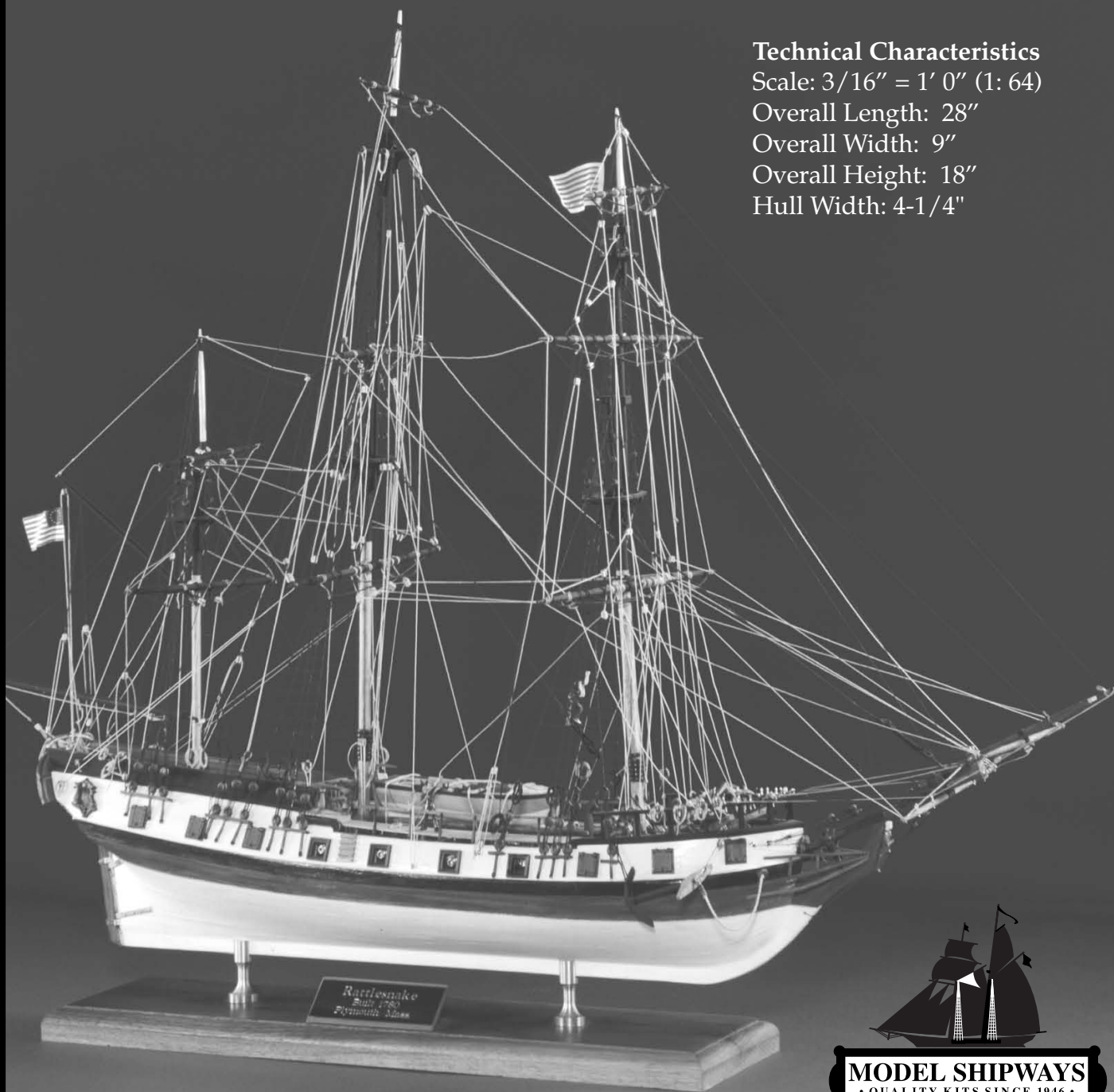

MODEL SHIPWAYS
• QUALITY KITS SINCE 1946 •

MODEL SHIPWAYS KIT

NO. MS2028

Instruction Manual

Massachusetts Privateer

Rattlesnake

1780

By George F. Campbell, 1963

Plank-On-Bulkhead Construction and Manual
By Ben Lankford, 1994

Model built by Bob Bruetsch

The Model Shipways Hull and Rigging plans for *Rattlesnake* were prepared in 1963 by Mr. George F. Campbell, who passed away several years ago. Mr. Campbell was a noted British marine artist, author, naval architect, and historian. He was a member of the Royal Institution of Naval Architects. One of his most noteworthy publications is *China Tea Clippers*. He also developed the drawings for the *Cutty Sark* restoration in England and authored Model Shipways' model handbook, *Neophyte Shipmodeler's Jackstay*.

The Model Shipways plans prepared by Mr. Campbell are based on Admiralty draughts and a reconstruction originally published by Howard I. Chapelle in his book, *The History of American Sailing Ships*, and also *The Search for Speed Under Sail*. The rigging and deck equipment is based on contemporary texts.

The Model Shipways kit of *Rattlesnake* initially offered a solid hull model. This kit has now been converted to a Plank-On-Bulkhead type hull. The P-O-B hull plans were prepared in 1994 by Ben Lankford along with this complete new instruction manual.

Copyright 1994

Model Shipways

Sold & Distributed by Model Expo, a Division of Model Shipways, Inc.

Hollywood, FL • www.modelexpo-online.com



Brief History

It was supposedly in 1781 that *Rattlesnake* was built as a privateer at Plymouth, Massachusetts for a Salem syndicate; John Andrews, and others. The Preble Papers in the Massachusetts Historical Society indicate that the designer and builder was John Peck of Boston. She was first commissioned on June 12, 1781 with Master Mark Clark at the helm. This, however, is early in the year. Consequently, there is some question about the actual building date. The ship could have been under construction in 1780 or earlier.

During 1781, at a time when privateering was losing its luster, British frigates still lay off the coasts of noteworthy American colonial towns, keeping tabs on shipbuilding departures, and raiding shipping centers. It was along these routes that *Rattlesnake* met her fate when she was captured by British 44-gun *H.M.S. Assurance*.

Rattlesnake was sent to England where she was taken into the Royal Navy and renamed *Cormorant*. Her hull lines were taken at the Plymouth Dockyard in 1782. In 1783, when the Admiralty found out they already had a ship named *Cormorant*, the ship was again named *Rattlesnake*. In 1784 or 1786, she was sold out of Naval service. Beyond that her history is not clear. One source says she was used by the French as a privateer and named *Le Tonnant*, but this is not confirmed by any authority.

Despite her moderate size, *Rattlesnake* was ship-rigged and impressive in appearance and feature beyond her broadside strength. The ship was 89' 3" long on deck, with a molded beam of 22', a mean draft of 8' 1-1/2", and 198-70/94th tons burthen. Her molded displacement was 221.3 long tons. Along with 85 men, she carried twenty 6-pounders only, a psychological ploy no doubt, but her lines reveal a fast and weatherly ship.

More History

For a fascinating history and technical discussion of privateering ships, and more detail on the *Rattlesnake*, refer to *The History of American Sailing Ships* and *The Search for Speed Under Sail* listed in the bibliography.

CONSTRUCTION STAGES & TABLE OF CONTENTS

Brief History	Pg 3	9. Kevels & Chesstrees	Pg 24
Introduction/Credits	Pg 2	10. Galley Chimney	Pg 24
Before You Begin	Pg 5	11. Channels	Pg 24
What You'll Need to Start Construction	Pg 5	12. Deck Buckets	Pg 24
How to Work With the Plans & Parts	Pg 6	13. Eyebolts & Cleats	Pg 24
Painting & Staining the Model	Pg 7	14. Rudder & Tiller	Pg 24
<u>Stage A: Framing the Plank-On-Bulkhead Hull</u>	Pg 8	15. Quarter Badges	Pg 25
1. Bending Wood	Pg 8	16. Cannons	Pg 25
2. Center Keel Assembly	Pg 8	17. Ship's Name	Pg 26
3. Installing the Keel/Stem & Sternpost	Pg 8	18. Ship's Longboat	Pg 26
4. Cutting the Rabbet	Pg 8	<u>Stage F: Mast & Spar Construction</u>	Pg 27
5. Installing the Bulkheads	Pg 8	1. The Importance of Scale	Pg 27
6. Installing the Transom Framing & Transom	Pg 10	2. Shaping & Tapering the Masts & Spars	Pg 27
7. Installing the Bow & Stern Filler Blocks	Pg 12	3. Building & Installing the Masts	Pg 27
8. Covering the Mast Slots	Pg 12	4. Building & Installing the Bowsprit & Jibboom	Pg 29
9. Installing the Gun Deck Waterway & Upper Deck Covering Boards	Pg 12	5. Building the Lower, Crossjack, Topsail, Topgallant & Spritsail Yards	Pg 31
10. Installing the Knightheads & Timerheads	Pg 12	6. Building the Spanker Gaff & Boom	Pg 31
11. Installing the Main, Forecastle & Quarter Deck Rails	Pg 13	<u>Stage G: General Rigging & Sailmaking Information</u>	Pg 31
12. Installing the Forecastle & Quarter Deck Breast Beams	Pg 13	Rigging Terms Defined	
13. Installing the Gunport Framing	Pg 13	1. Rigging Options	Pg 31
<u>Stage B: Planking the Plank-On-Bulkhead Hull</u>	Pg 14	2. Using the Rigging Plan	Pg 32
1. Getting Started	Pg 14	3. Rigging Line & Block Sizes	Pg 32
2. Planking Battens & Belts	Pg 14	4. Treating the Lines	Pg 33
3. Planking Butts	Pg 14	5. Belaying Pins & Their Lines	Pg 33
4. Spiling	Pg 15	6. Rigging Tools	Pg 34
5. Fastening the Planks	Pg 15	7. Blocks & Deadeyes	Pg 34
6. Planking the Outer Hull	Pg 15	8. Sailmaking	Pg 34
7. Planking Inboard (Ceiling Planks)	Pg 18	9. Rigging the Model <u>Without</u> Sails	Pg 36
8. Planking the Decks	Pg 18	<u>Stage H: Standing Rigging</u>	Pg 37
<u>Stage C: Completing the Basic Hull Structure</u>	Pg 19	1. Shrouds	Pg 37
1. Correcting & Sanding	Pg 19	2. Backstays	Pg 37
2. Building the Head Rails	Pg 19	3. Fore & Aft Stays	Pg 37
3. Gunport Lids	Pg 19	4. Detail at the Tops	Pg 37
4. Building the Gangways	Pg 19	5. Bowsprit Rigging	Pg 37
5. Natural Wood/Double Plank Option	Pg 19	6. Footropes	Pg 37
<u>Stage D: Mounting the Hull</u>	Pg 20	<u>Stage I: Running Rigging</u>	Pg 41
1. Mounting Board with Two Pedestals	Pg 20	1. Fore Staysail, Fore Topmast Staysail & Jib	Pg 41
2. Launching Ways	Pg 21	2. Fore and Main Course, & Mizzen Crossjack Yard	Pg 41
<u>Stage E: Adding the Hull Details</u>	Pg 21	3. Fore, Main & Mizzen Topsails	Pg 41
1. Locating Deck Fittings & Structures	Pg 21	4. Fore & Main Topgallant Sails	Pg 43
2. Topsail Sheet Bitts, Fore Brace Bitts, Riding Bitts & Gallows Bitts	Pg 21	5. Spanker	Pg 43
3. Ladders	Pg 21	6. Spritsail & Spritsail Topsail	Pg 43
4. Hatches & Gratings	Pg 21	7. Miscellaneous Rigging	Pg 43
5. Binnacle	Pg 21	Final Touches	Pg 43
6. Capstan	Pg 21	Scale Conversion Table	Pg 44
7. Catheads & Anchors	Pg 21	Rigging Line Diameters	Pg 44
8. Elm Pumps	Pg 24	Millimeters/Inches Conversion Chart	Pg 44
		Bibliography	Pg 45

BEFORE YOU BEGIN

The *Rattlesnake* is a very beautiful ship and makes a splendid model. The plank-on-bulkhead hull construction with laser-cut parts offers a unique building experience. It assures an accurate hull form, and develops an understanding of how real ships are constructed.

The kit is supplied with a set of Britannia, brass, and wooden fittings to eliminate problems in making or machining such parts from scratch, which may be beyond the ability or resources of the average modeler. Many of these fittings, however, will require final finishing before they are suitable for installation on the model. This will be especially true for the Britannia fittings and will be discussed later.

This kit will provide less experienced modelers with the opportunity to acquire some scratch-building techniques. As an aid, various techniques will appear throughout the instructions. While the modeling progresses, you will see where you may want to substitute some of the kit fittings with your own creations. By all means try them, especially if you think you can improve the model. The worst that can happen is a little lost time. But, the experience gained will be most valuable for future projects.

If you are a beginner, take your time. This model has a fair amount of detail and small parts. Make sure you complete one stage before moving to the next. When things go awry, consider doing it over.

WHAT YOU'LL NEED TO START CONSTRUCTION

The following tools and supplies are recommended for the construction process. Modelers who have built before may have their own favorites.

A. Knives

1. Hobby knife
2. No.11 blades

B. Files

Set of needle files

C. Clamps

1. A few small C-clamps
2. Wooden clothespins
3. Rubber bands, #16 and #33

D. Tool Set

A small carving tool set or individual gouges and chisels for carving center keel rabbets, the counter block, stern and bow filler blocks, tapering the stem, and carving the ship's longboat.

E. Sharpening Stone

Necessary to keep tools razor sharp

F. Boring Tools

1. Set of miniature drills: #60 to #80
2. 1/16", 3/32", and 1/8" drills
3. Pin vise

G. Miscellaneous

1. Tack hammer
2. Tweezers (a few)
3. Small fine pointed scissors
4. Miniature pliers
 - a. small round
 - b. flat nose
5. Bench vise (small)
6. Soldering iron or torch
 - a. solder
 - b. flux
7. Sewing thread (for seizing; other rigging in kit)
 - a. black
 - b. tan
8. Beeswax block (for treating rigging lines)
9. 1/2" or 3/4" masking tape
10. Wire cutters (for cutting fine wire and strip metal)

H. Sandpaper

Fine and medium grit garnet or aluminum oxide sandpaper (#100 to #220)

I. Sail cloth

Light weave cotton or linen cloth if you intend to add sails. A suitable cotton cloth is available from Model Expo.

J. Finishing

1. Paint Brushes
 - a. fine point for details
 - b. 1/4" to 1/2" flat square for hull

K. Supplies

(will be covered in detail in the Painting & Staining section and throughout the instructions)

1. Paints
2. Primer
3. Stains and varnish
4. White or Carpenter's (yellow) wood glue
5. Super glue
6. Five-minute epoxy glue
7. Wood filler

Note about glues: White glue, or Carpenter's wood glue (yellow in color; also available in tan color), will suffice for most of the model. Five-minute epoxy provides extra strength for gluing fittings. Cyanoacrylate glue (super glue), such as Jet, can be used for quick adhesion and is ideal for adding a touch to a rigging seizing to hold it in place. The best super glue for most applications is a medium viscosity gap filling type. The watery thin type is recommended to fill a narrow crack by capillary action, and for quickly securing hull planking to the bulkheads.

HOW TO WORK WITH THE PLANS & PARTS

Before starting model construction, examine the kit and study the plans carefully. Familiarizing yourself with the kit will serve two purposes. First, it will let you determine that all parts have been supplied as listed. And second, you'll be surprised at just how quickly handling the parts allows you to better understand the kit requirements. Try to visualize how every part will look on the completed model. Also, determine ahead of time what must be done first. The instructions will help you in this regard, but a thorough knowledge of the plans at the outset is essential.

It is suggested that all small fittings and hardware be sorted into labeled boxes or compartments to avoid loss during the building process.

1. The Plans

Four Plan Sheets are provided:

1963 Plans by George Campbell:

1. Hull Details and Lines Plan
2. Rigging Plan

1994 Plans by Ben Lankford:

3. Laser-Cut Wood Patterns
4. Plank-On-Bulkhead Hull Construction

In addition, a set of sketches appears throughout this instruction manual to further illustrate the various stages of construction.

The *Rattlesnake* kit is manufactured to a scale of $3/16" = 1' 0"$. Each plan sheet is drawn to the exact scale that the model is to be built, except where some details have been enlarged for clarity. Most dimensions can be lifted directly off the plans by using a set of draftsman dividers or by using a "tick" strip, which is simply a piece of paper used to "pick up" the dimensions (a roll of calculator tape works very well). Lay your paper strip over the plan and mark the lengths of items carefully with a sharp pencil. Then use the strip to transfer the marks to the wood or item to be made to scale. It is handy to have a triangular architect's scale. Measuring and cutting parts using the $3/16"$ scale gives you a better feel for real ship sizes. It also gives you a conversion for the full ship size dimensions shown on the plans. At $3/16"$ scale, one inch in full ship size equals $1/64"$. Keep this in mind as you work. You will soon know, for example, that if you see something 4 inches wide full scale, your model part will be $1/16"$.

2. Making Allowances Along the Way

Try to be exact when following the plans, but use common sense along the way.

You may need to make adjustments or allow for small differences in how your model is shaping up; perhaps your mast has too much rake (the angle at which it sits). When lines go to belaying points they should not drape over parts or conflict with other lines. If necessary, move a belaying point or a fairlead. In other words, put yourself on the ship and use your judgement.

3. Understanding Hull Lines

Beginners may not be familiar with hull lines. Buttock lines are vertical longitudinal planes cut through the hull. Waterlines are horizontal planes, and sections are transverse vertical planes. All of these lines define the hull shape and are used by the draftsman to fair the hull form (create regular even curves).

A complete set of hull lines is shown on the George Campbell plans but they are not really needed for this particular model. With the plank-on-bulkhead construction, the laser-cut bulkheads and center keel define the hull form. These are based on the *Rattlesnake* hull lines to outside of the planking, but are made smaller to allow for the thickness created by adding the planks.

4. Using Basswood Lumber

Standard cut basswood is available in sheets and strips. Normally, thickness is available in $1/32"$, $1/16"$, $3/32"$, $1/8"$, $5/32"$, $3/16"$, $1/4"$, and $1/2"$. Widths of strips are available in the same increments. Sheets may be 1", 2", 3", or 4". A thickness of $3/64"$ is also a manufactured thickness, but not found in many catalogs. However, if needed, it will be provided in Model Shipways kits.

Note: Your kit may contain European limewood instead of the basswood most of us are familiar with. For further information see the notes in the parts list.

For the model scale $3/16" = 1' 0"$, $1/64"$ is equal to 1" full ship size. $1/32"$ is equal to 2", and so on. Generally, the available sizes of basswood fit the full ship size quite well and the strips or sheets can be used directly. Occasionally, you will find a size where the strip must be thinner than the basswood size supplied. In order to use a correct thickness, you will need to sand down a certain thickness of basswood. This is easily done with a sanding block before making a part.

If you are fortunate enough to own a powered sanding thickness planer for models, all the better. These can be purchased commercially. You can also make

your own using a drum sander in a drill press. Clamp a block alongside the sander so the wood can be inserted between the block and sander. It's a makeshift deal, but it works quite well.

It is a good idea to sort the wood contained in the kit by thickness. When building a certain part, select a suitable size from the proper thickness pile. After cutting what you need, return the remaining piece to that thickness pile. This saves a lot of time looking for a given thickness. Don't worry about using a piece for one item that was intended for another. It will all come out in the wash. There is enough extra wood in the kit so you should not run out before you complete the model.

5. Cast-Metal Fittings

The kit is supplied with Britannia metal castings. The Britannia metal is a great improvement over the white metal that was used in some older kits. Unlike white metal and pewter, Britannia does not contain lead, so there are no possible corrosion problems. Many of these fittings, however, will require final finishing before they are suitable for installing on the model.

Before painting the cast-metal fittings, clean them up by removing all the mold-joint flash. To do this, use a No. 11 hobby blade to cut the flash, then file or sand with fine sandpaper. It is also suggested that you clean the fittings thoroughly with warm soapy water before applying primer. Make sure they are rinsed thoroughly and allowed to dry before painting.

6. Soldering & Working with Brass

The *Rattlesnake* is a ship from a period that had very little iron fittings. Consequently, you will not be required to do much soldering, if any. Gudgeons, pintles, and chain plates could be soldered or simply glued. If you do solder, the secret is to keep the parts to be soldered clean, and keep the end of your soldering iron clean and well tinned. File or sand the parts, then keep your fingers off. Heat the parts first, then touch the solder. File off any excess solder.

PAINTING & STAINING THE MODEL

It may seem strange to begin an instruction manual with directions on applying the finishes to the model. Not so! Much time and effort can be saved, and a more professional result can be obtained, if the finishing process is carried out during construction. Proper timing in application of finishes and the use of masking tape to define painted edges should eliminate unsightly glue marks and splotchy stained surfaces. In the end, following these general suggestions will be to your advantage.

Paint

Use a flat-finish paint such as the model paints made by Floquil, Polly-S, Testors, Humbrol, and Model Masters. You could also use artist's paints by Jo Sonja (used by many bird carvers) or Holbein Acryla Gouache. These paints are a combination acrylic-gouache.

Paint Colors

The recommended color scheme for the *Rattlesnake* is as follows:

Topside Rails: Yellow Ochre

Quarter Deck Outboard Bulwark Planking between Rails: Black

Outboard Planking from Rails down to the top of Wales: Yellow Ochre

A Parallel Band about 1/2" wide from top of the Wales, and including the Upper part of the Stem: Black

Head Rails: Yellow Ochre

Hull Bottom below the Black Band: White or Tallow (or lighter tallow plus white). Note: Tallow is an ivory color and is available pre-mixed in Floquil model paint available from Model Expo.

Stern Window Frames: White

Center Dummy Window Panes: Pale Blue

Figurehead: Any bright colors

Bulwarks Inboard: Grey

Decking: Natural light Tan or Grey stain with low sheen varnish

Masts, Spars and Deck Bitts: Burnt Sienna stain, or any Tan/Maple colored stain with low sheen varnish

Tops & Doublings (top up and including mast caps), and Bands around Fore and Main Mast: Black

Longboat: Tallow or White bottom, Natural varnished sides and interior (Tan or Maple stain), Black outboard molding and Red spray rail

Ironwork: Black

Standing Rigging: Tarred (Black or Dark Brown)

Running Rigging: Tan or Weathered Grey

Primer

Use a Grey primer. Floquil is excellent. The Grey color will highlight sanding scratches and other defects better than White primer. Prime all woodwork to be painted, and prime all metal fittings. Lightly sand the primed items. Use a spackling compound, such as Pic-n-Patch brand, to fill any scratches and defects, then re-prime. Careful! Do not prime parts to be stained or varnished.

Stains & Finishes

For natural finished wood, use a protective coating after staining such as low sheen polyurethane varnish or the Floquil coatings. You can also use an oil-resin mix such as natural Minwax. Floquil stain, or Minwax stains can be used to tone the wood.

Brushes & Procedures

Use good quality soft sable or synthetic hair artist brushes. A small pointed brush is good for details. For the main hull areas, use a 1/4- to 1/2-inch flat brush.

Before painting, clean the model with a tack rag. Apply your paint in smooth even strokes, overlapping the strokes as you go. Thin the paint enough to eliminate brush strokes, but not run. You will need four or five coats of the light colors to cover the Grey primer, and maybe only two coats of the dark. Check your finish between coats, and sand or add spackle as necessary to get rid of any blemishes.

Anywhere two colors meet, use masking tape. Electrician's black plastic tape is ideal. It leaves a nice edge and is not overly sticky. Do not use drafting tape. The edges are wrinkled and paint may run under them.

STAGE A

FRAMING THE PLANK-ON-BULKHEAD HULL

1. Bending Wood

Building a P-O-B hull requires some wood bending and twisting, and the wood must remain in the desired position so as not to put too much stress on glue joints and fasteners. The term "steam-bent" will be used throughout the text whenever such a process is necessary. However, here are three ways to bend wood.

Steam-bending - For actual steam-bending, hold the piece over a kettle of steaming water and bend. Hold the wood in position until it cools. It should remain nearly in that position, but may spring back slightly.

Soaking - Another method is to soak the piece in warm water for several hours. Try adding a little household ammonia to the water. You can also use pure ammonia. This speeds up the soaking process and makes the wood fibers slippery so the wood is easily bent. Hold the wood in position with a form after soaking and let it dry completely.

Hot iron - You may also bend wood quickly over a soldering iron, but don't let it get too hot. A large soldering iron with a tubular end is ideal. The tube near the handle is not as hot as the very end. It is also possible to purchase model plank-bending irons commercially. They are designed for controlled heat.

2. Center Keel Assembly

The first step in constructing the hull is to assemble the two laser-cut center keel pieces. First, use a sharp pencil and mark the bulkhead locations below the slots and the WL reference line. This line is used to locate Bulkheads "A" through "M" on the center keel. Mark on both sides of each center keel piece. Be especially critical in locating the reference line. Measure from several points from the plans. The reference line is a key to proper alignment.

Place the two parts, 1 and 2, over a sheet of wax paper or plastic wrap, on a flat building board or table. Glue the joint with white or carpenter's wood glue. Use a steel or aluminum straight edge to align the WL reference line. Place a weight on each piece to hold it down while the glue dries. Let the glue dry at least overnight, preferably 24 hours (see figure 1).

FIG. 1 - Assembling The Two Center Keel Pieces

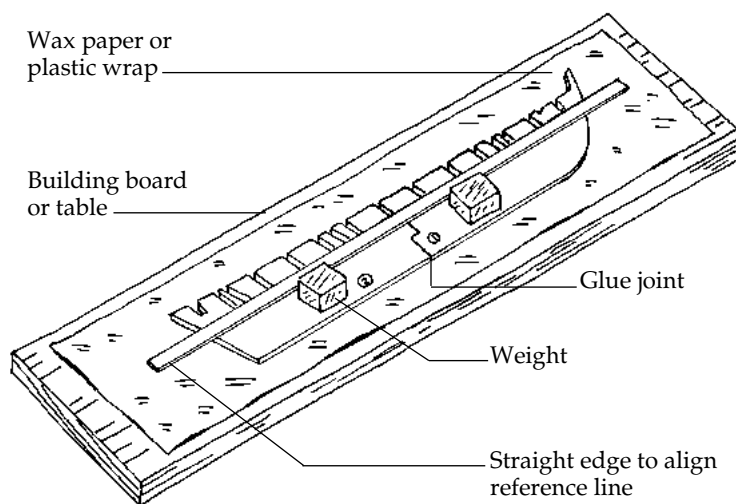

3. Installing the Keel, Stem & Sternpost

For this particular model, the center keel is only 5/32" thick. With 1/16" hull planking, after cutting a rabbet on both sides, there is not much left of the center keel for attaching the keel, stem and sternpost. Consequently, it is recommended that you first install the keel, then cut the rabbet as you add planking. The keel will remain secure along most of the hull by this approach.

The keel, stem, and sternpost should now be added. Taper the stem as shown on the plans before installing it. Dowels can be used to help align and hold the pieces (see figure 2).

4. Cutting the Rabbet

With the keel now in place, the rabbet is the glue line between the center keel and the keel. The bearding line is the intersection of the center keel and the inside face of hull planks. Mark the bearding line on both sides. The bearding line appears along the sternpost, keel, and stem. Measure from the P-O-B plans. Use a hobby knife and cut the rabbet to a depth of about 1/32". Cut on or slightly above the glue joint. Now, using a chisel, start the rabbet cut at the bearding line and cut toward the rabbet. When the planking is installed, the planks will lie

flush on the cut portion from bearding line to rabbet (see figure 3). As you cut the rabbet, continue to use the hobby knife to gradually work your way down to the full 1/16" depth for the rabbet to fit the planks.

5. Installing the Bulkheads

The bulkheads are labeled A through M. Compare the laser-cut bulkheads with the plans to determine which is which and label each bulkhead. Check each bulkhead to make sure it will slide into the center keel slots. Machine tolerances during laser cutting may provide a too tight fit. Sand the slots, if necessary, until the bulkheads slip on. The fit should be snug. You need a little tolerance for glue.

The bulkheads include cutouts at the gun deck. Also, the bulkheads include extensions for rail stanchions. These areas are only 1/16" thick, so be careful handling them to avoid breakage. After the stanchions have been planked, with hull planks on the outboard side and ceiling planks on the inboard side, the shell will have obtained maximum strength.

On each bulkhead, mark the location of the WL reference line in pencil. This mark should line up with the WL mark on the center keel. This alignment assures that the hull form is accurate and that each bulkhead is correctly related to the others.

FIG. 2 - Installing The Keel, Stem & Stern

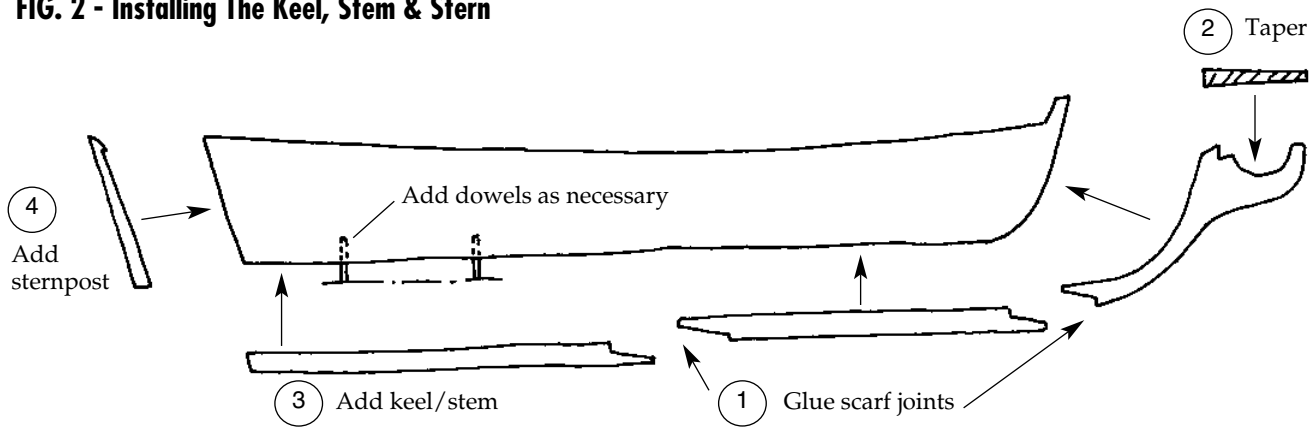

Next, mark the bevels on the bulkheads. Use a tick strip to transfer the bevel line as shown on the plans, or cut the bulkhead patterns from the plan and glue them onto the bulkheads. You can also lay the patterns over the bulkheads and use a pin prick to locate the bevels. Cut the bevels with a #11 hobby knife blade as shown (see figure 4).

Some of the bevels are very slight, especially the deck bevels and the side bevels near amidships. These slight bevels are not drawn because they are hardly measurable. They can be sanded after the bulkheads are installed instead of pre-cutting them.

Glue the bulkheads in place, making sure that the WL marks on the bulkheads and the center keel line up. Use a square to make each bulkhead perpendicular to the center keel, then tack a temporary strip to the top to hold the bulkhead in place while the glue dries (see figure 5).

After all bulkheads are in place, tack or tape a temporary batten on each side of the hull just below the gun deck as shown (see figure 6). This is a critical step. Measure the spacing between bulkheads and retack the battens until the hull is aligned. Even though the center keel was assembled flat, it could warp out of line. The result could be that you wind up with a banana-shaped hull. Check the spacings between bulkheads, and port against starboard spacings. Look at the hull to see if it is properly aligned.

When you are satisfied that the hull is aligned, check that the bottom of each bulkhead feathers out and lies precisely on the bearding line. Trim as necessary to line up. Also, check that the top of each bulkhead at the centerline is flush with the top of the center keel. Since all alignment is based on the WL marks, there could be some slight errors. Sand or add shims as necessary until the bulkheads and center keel surfaces are flush (see figure 7).

FIG. 3 - Cutting The Rabbet in The Center Keel

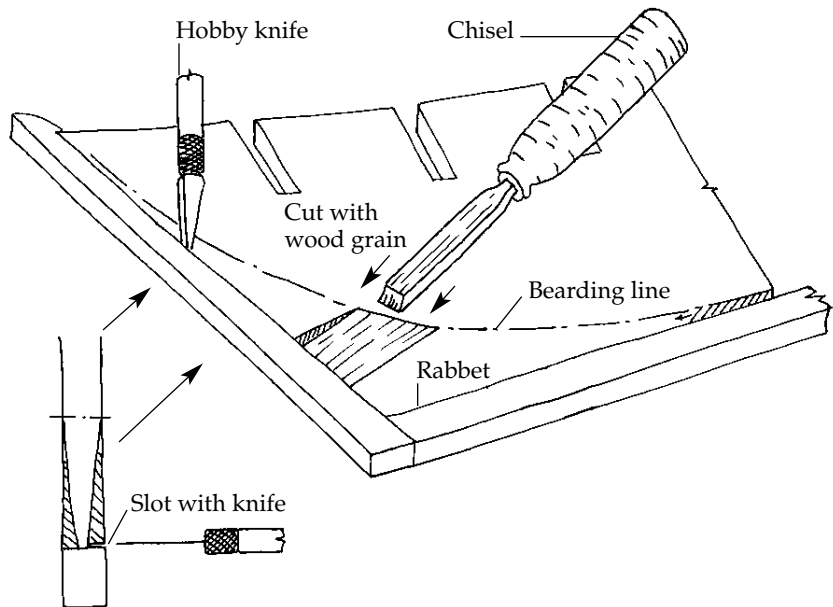

FIG. 4 - Shaping The Bulkheads

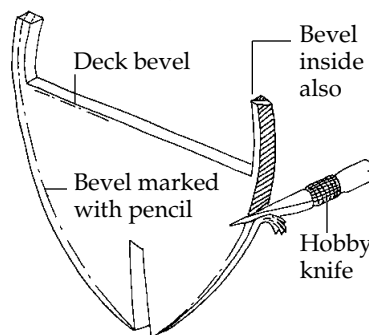
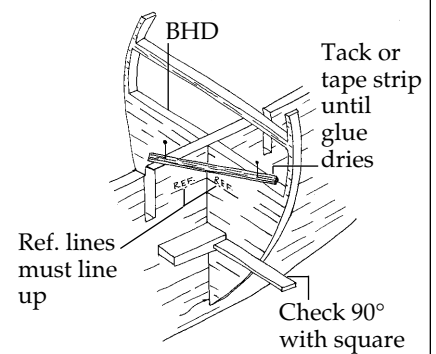

FIG. 5 - Installing The Bulkheads



Next, check the fairness of the hull form and sand in the slight bevels that were not pre-cut. To do this, use a stiff basswood batten about 3/32" thick and lay it across the bulkhead edges and decks in various locations (see figure 8). If not fair, sand the bevels that stick out, or add shim material if there are dips. This is an important check. When you start planking, the planks must lie flat against the bulkheads without incurring any bumps and dips on the surface. A model like *Rattlesnake* has many bulkheads, so it is possible for manufacturing or assembly errors to creep in.

6. Installing the Transom Framing & Transom

Carve the counter block, and glue it to the aft side of **Bulkhead M** and on top of the center keel. Glue the port and starboard laser-cut outboard transom support pieces and two inboard transom supports on top of the counter block. The forward end of the outboard pieces fit against the **Bulkhead M** bulwark stanchion extensions.

Follow the plans when carving the counter block. The bottom of the block has the counter curve. The forward side matches **Bulkhead M**. The aft side of the block indicates the slope and curvature of the transom. At the center, there is a cut-out so the rudder stock can pass through (see figure 9).

The transom is a laser-cut piece. While it was made up of planks over stern frames on the real ship, for the model a solid piece has been provided so no planking is required. Glue the transom to the side and center supports (see figure 10). There are two openings on each side of the transom for windows, and at the center for a fake window. The window frames are laser-cut and can be inserted in the holes. First cover the inside with plastic sheet and paint light blue or black. The center window was a dummy window on the real ship. Paint the panes pale blue. Add the outside frames with 1/32" strip, sanded half-round. Add the lower moldings as shown in the sketch.

The stern carving is supplied as a Britannia fitting, but you can carve your own from wood if desired. If you use the fitting, it will need shaping a bit to fit the transom. Cut sloped edges as required.

After the planking is done you must add the fashion piece at the transom. This is discussed now to avoid any confusion (see figure 11). Finally, drill some holes in the top edge of the transom to receive the rail stanchions.

FIG. 6 - Aligning The Bulkheads, Using Battens

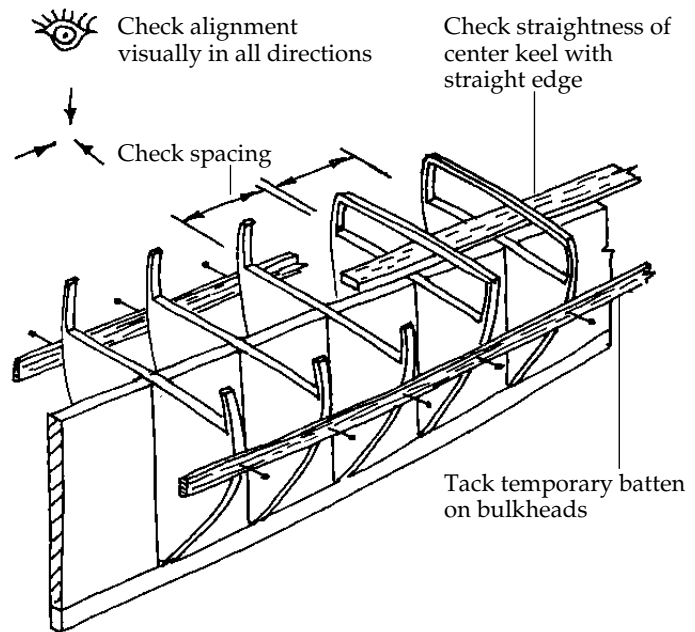

FIG. 7 - Making Sure Bulkhead & Center Keel Surfaces Are Flush

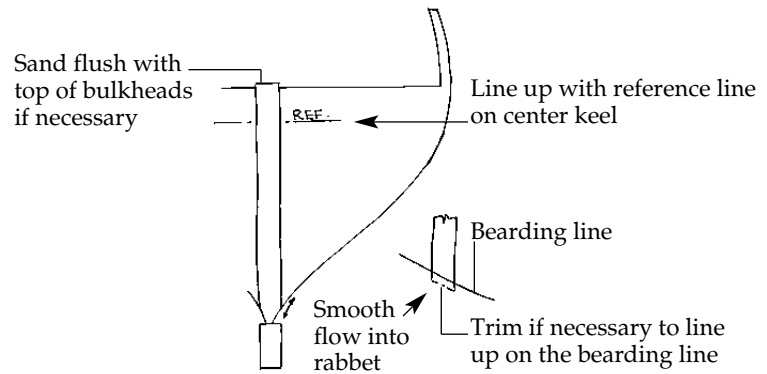

FIG. 8 - Check The Fairness Of The Hull Form

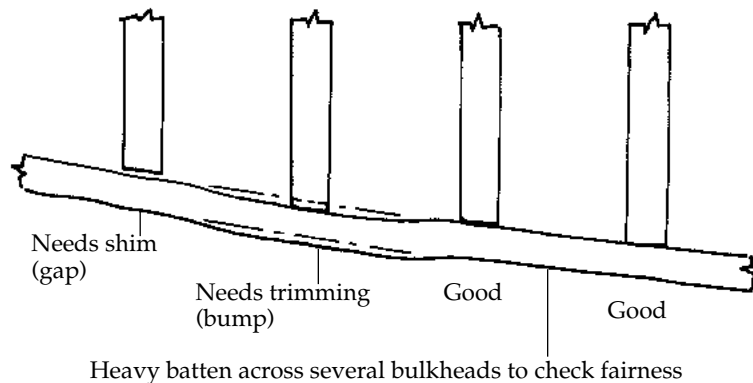

FIG. 9 - Carving The Counter Block At Bulkhead "M"

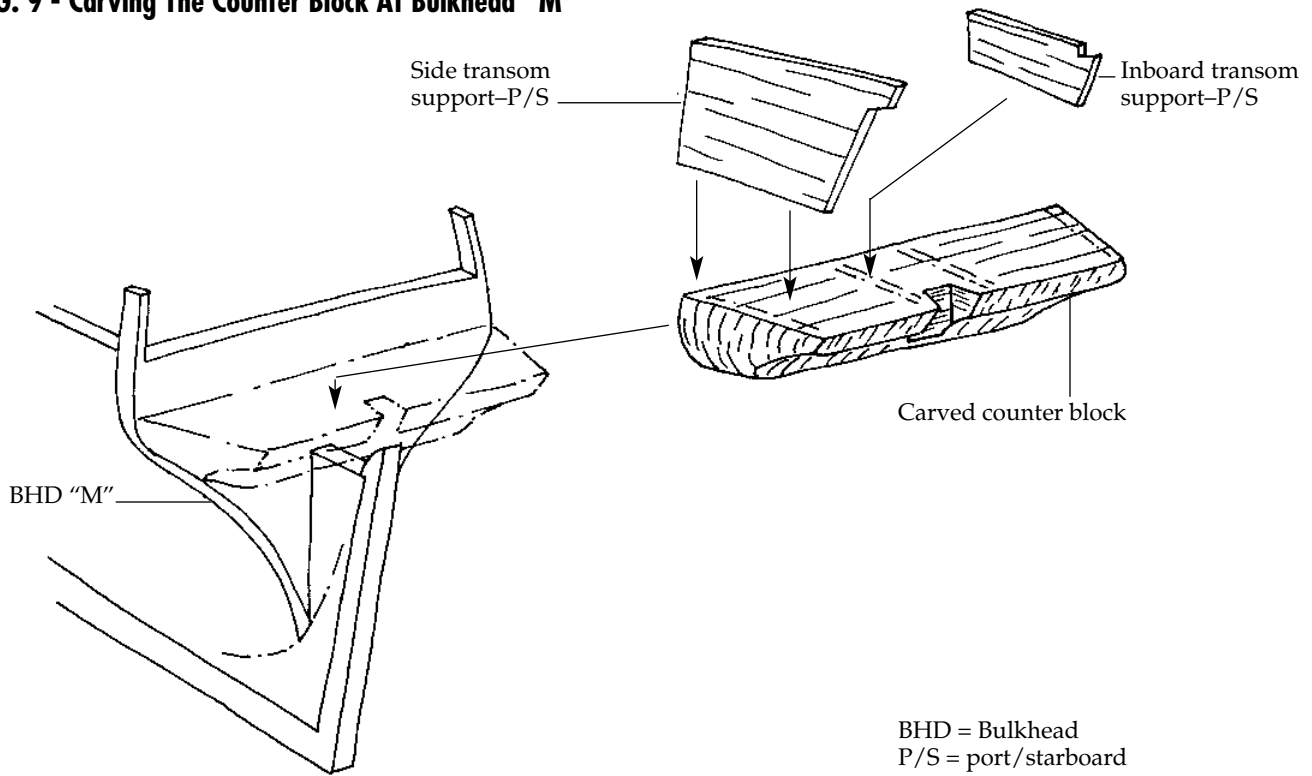

FIG. 10 - Installing The Transom

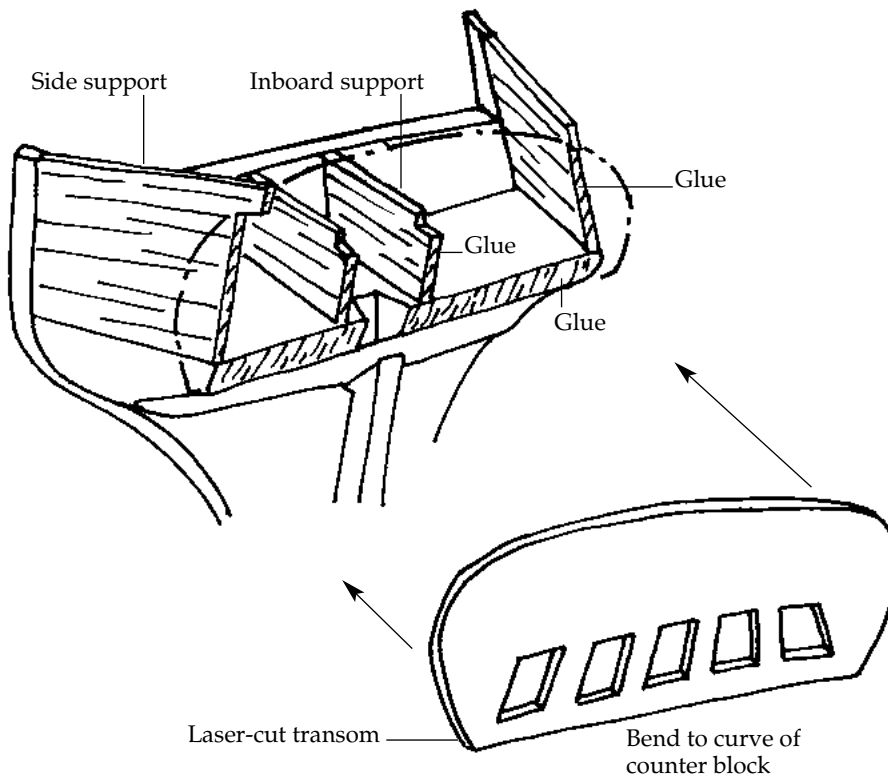
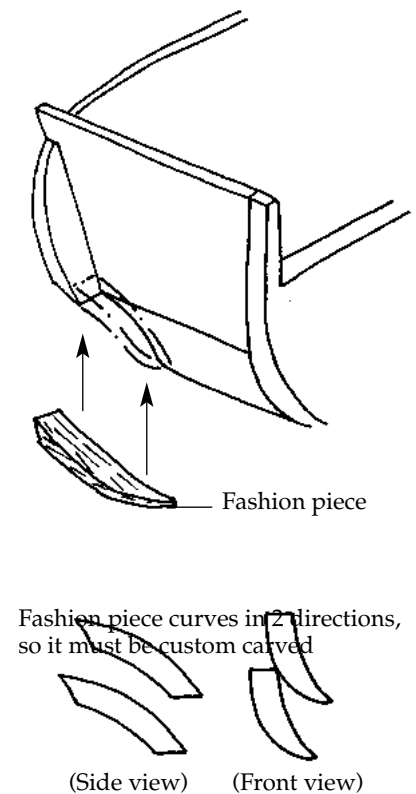

FIG. 11 - Installing The Two Fashion Pieces



7. Installing the Bow & Stern Filler Blocks

Forward of **Bulkhead A** and aft of **Bulkhead M**, add the filler blocks as shown on the plans. Carve the blocks to the hull form. The purpose of these blocks is to have more support where the planks take a severe curve. You will still need to steam bend planks at the ends, but with the blocks in place, the planks are not as likely to break as they pass over the last bulkheads. In addition, the forward block gives a solid piece for inserting the timberheads and knighthead forward (see figure 12).

8. Covering the Mast Slots

On both sides of the mast slots in the center keel, add the pieces shown on the P-O-B plan. Cut from scrap wood. Glue them securely, because you can't get to them after the decking is installed. The mast slots are slightly larger than the actual mast. The mast can be wedged in the hole when installed.

9. Installing the Gun Deck Waterway & Upper Deck Covering Boards

At the gun deck level, add the waterway along the deck edge inboard of the bulkhead extensions (see figure 13). You can omit the waterway in the officer's quarters since it cannot be seen.

At the forecastle deck, the covering boards at the edge of the deck as shown in the sketch are laser-cut. Add these next. Aft, add the covering boards as shown on the plans and the sketch. These must be made from stripwood. Actually, this is a fake covering board. You will have a separate piece inboard and a separate piece outboard instead of a solid piece fitted over frames. For the outboard piece, plank the hull first, then add the strip, or use the option shown on the plans for a single piece.

10. Installing the Knighthead & Timberheads

Make the knighthead and timberheads and install them in a notch in the forward filler block (see figure 12).

FIG. 12 - Installing The Bow Filler Block

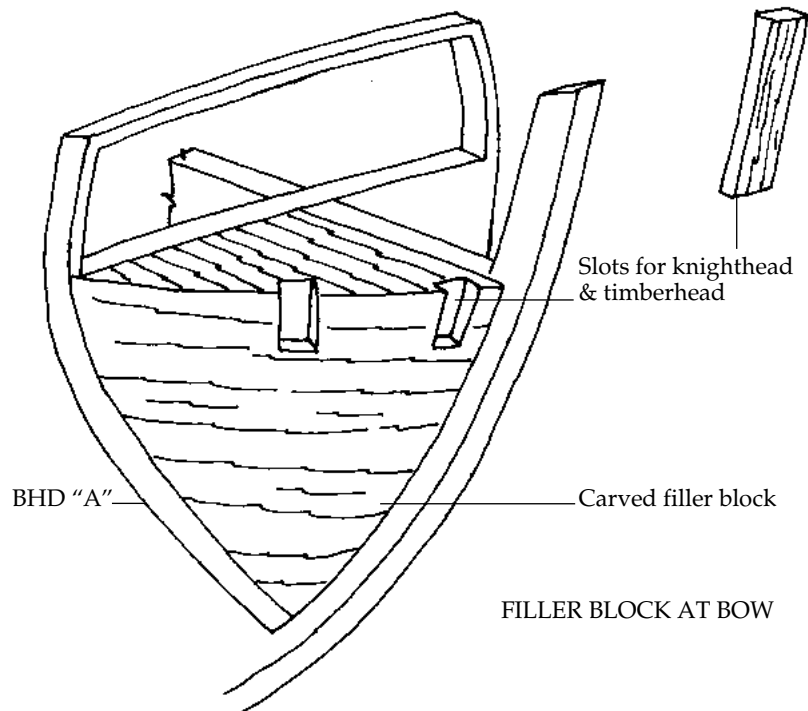
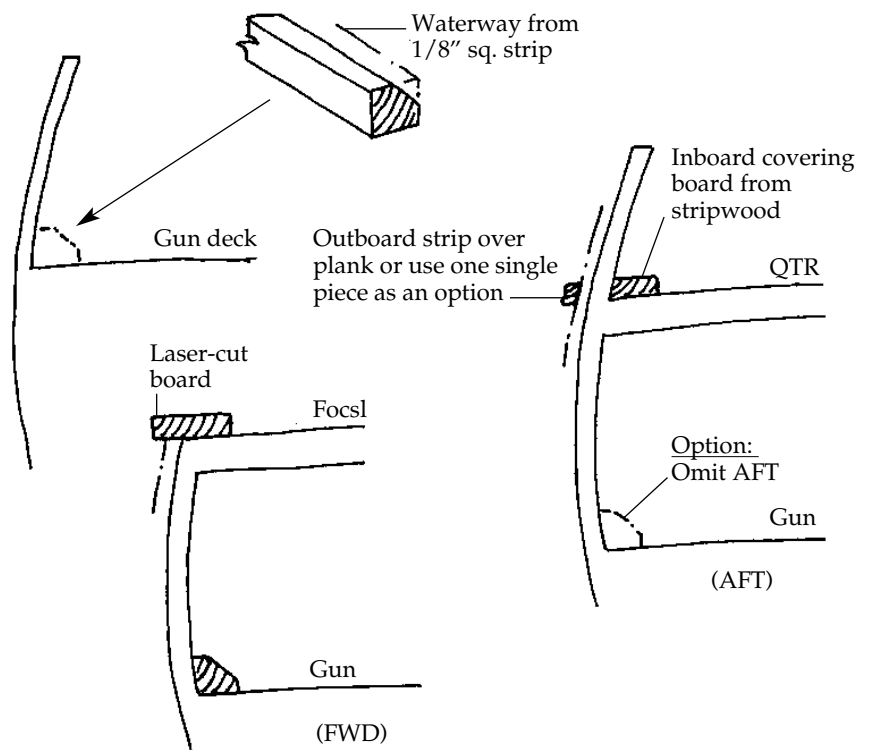

FIG. 13 - Gun Deck Waterway & Upper Deck Covering Boards



11. Installing the Main, Forecastle & Quarter Deck Rails

Because the forecastle deck has more curvature, it has been laser cut for you. Cut all the other rails from strip wood. At the forecastle deck, first make and insert the rail stanchions in the pre-cut holes in the covering board. When adding rails, use a pin or dowel for alignment and for securing the rail atop the stanchions and bulwarks (see figure 14).

At the various steps, you will need to create scroll work from one rail to the other. Carve these scrolls as shown (see figure 15).

12. Installing the Forecastle & Quarter Deck Breast Beams

The breast beams forward and aft must be added before you do the deck planking. The aft beam ties into a bulkhead but the forward beam has nothing yet at the sides to tie into. Add a strut between bulkheads for end support (see figure 16).

13. Installing the Gunport Framing

Use 1/16"-square strips to frame the gunports and the small oar ports in the hull. The strips fit between the bulkheads (see figure 17).

Most of the basic framing is now complete and you are ready to start planking. Take a moment to look over what you have so far. Recheck the fairness of the hull. Making corrections now will allow the planking process to go smoothly.

FIG. 14 - Installing The Main, Forecastle & Quarter Deck Rails

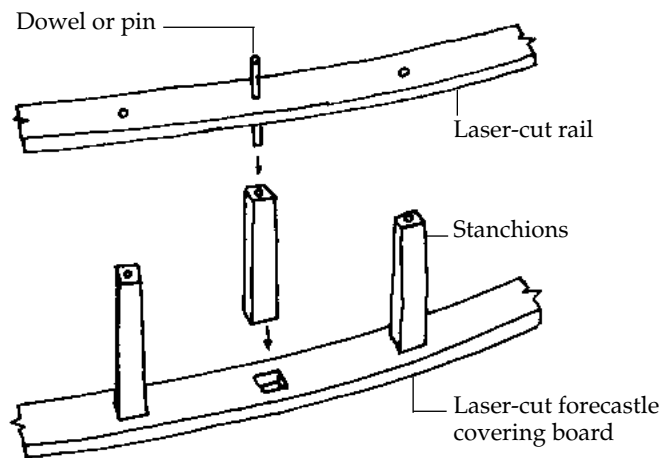

FIG. 15 - Carving The Scrolls For The Rails

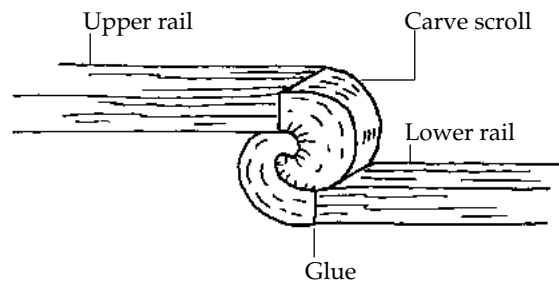

FIG. 16 - Installing The Forecastle & Quarter Deck Breast Beams

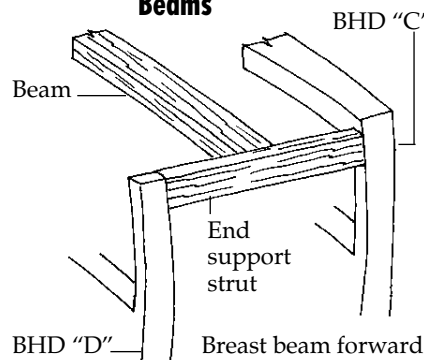
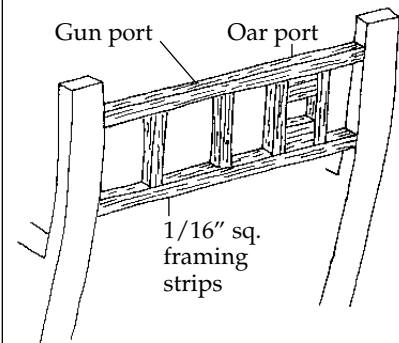

FIG. 17 - Installing The Gunport Framing



STAGE B

Planking the Plank-On-Bulkhead Hull

Before getting started, it's a good idea to know some of the more common shipbuilding terms that apply to the planking process. Consider the following few key words as you work:

1. A *plank* is a single length of wood used for planking a hull or deck. A planking *strake* is a continuous line of planks, butted against each other from bow to stern, or wherever the strake begins or ends.
2. A *garboard* strake is that strake of planking adjacent to the keel.
3. The *sheer* strake is the uppermost main hull strake.
4. The *wale* is a heavy layer of strakes below the sheer strake along the hull's side. For the *Rattlesnake* the upper edge of the wale protrudes beyond the planking above. However, there is no lower wale edge. The heavier wale planks gradually taper into the lower planking so the hull surface is flush from the top edge of the wale down to the keel rabbet.
5. When discussing planking *belts*, we are talking about a group of planks along the hull. Belts are laid out using *battens*, which are temporary strips of flexible wood used to locate the belt. A *ribband* is also a batten, used on boats and ships to hold the frames in place while the planking is being added. Ribbands are removed as the planking is completed.
6. *Spiling* is a term used to describe a process for marking and cutting a plank to a given shape.
7. *Edge bending*, also called *springing*, is when you bend a plank edgewise.
8. When planking, the use of the word *fair* refers to smooth, gradual curves.
9. *Nib* or *nibbing* is where one plank runs into another at a sharp angle. In order to eliminate the feathered edge, the plank is cut off on the end and it is fitted into a similar cut in the other plank. Nibbing is generally applied to decks, but hull planks also can be nibbed.
10. A *stealer* is a plank inserted into another plank, or notched in between two adjacent planks when the planks become too wide. Or, when two planks are tapering toward a narrow end, it may be necessary to cut off both planks, then substitute a wider plank to continue so there will be enough wood left for fastening the end of the plank. I'm at a loss

FIG. 18 - Planking With Stealers

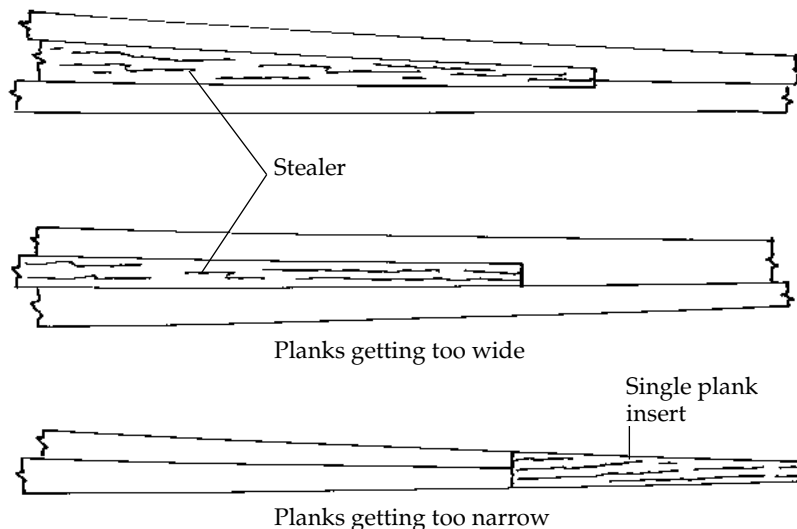

for the proper term for this. One model publication calls it a *joggle* plank, but I'm not sure about that. Stealer is a common term, but joggle plank is not.

11. The *counter* is the underside of the overhanging portion of a ship's stern.

1. Getting Started

The planking process is tedious and you should plan on spending some time doing the job. Work on each plank as a project unto itself. Rushing will only result in frustration and a poor result.

Since both sides of the hull will be identical, you can cut two planks the same shape at once. Fit the plank on one side, then the other. Before starting, place the hull upside down and secure it in a vise or cradle. Something portable would be ideal so you can rotate the hull easily.

2. Planking Battens & Belts

It is easier to plank a hull by first dividing the hull into a series of belts. The belts flow along the hull in smooth curves. Each belt is designed so the planks lay against the hull without excessive edge bending of the planks. They sweep up at the ends like the deck sheer. Within each belt, the planks are usually spaced evenly, tapered, and fitted as required. The belts help accomplish the

complete job without accumulating errors as you work.

When selecting a belt width and the number of planks within each belt, you need to consider how the planks will lay against the frames and how they will taper. If the planks are too wide, they will not lay flat on the bulkheads. Also, you don't want them to taper so much that there is no width left for fasteners. This would require substituting a larger plank for two to increase width. Also, in some areas, the planks may get wider rather than taper. If they get too wide, a stealer plank must be cut into the plank. While these alterations are acceptable and are used on many ships, it is best to design the run of planking to limit the number of inserts (see figure 18 which illustrates some of these inserts).

For the *Rattlesnake* model, a planking layout has already been developed for you. The layout is shown on the P-O-B plan.

3. Planking Butts

Before you start, consider the planking butts. Since the lengths of wood cut from trees are generally shorter than the overall lengths of real ships, shipbuilders generally have to work with planks 20 or 30 feet long. Some modelers think it is easier to use a plank length the full length of the model. Fake butts can be scribed in later or omitted. Granted, this can be done. It's really up to the

FIG. 19 - Staggering The Planking Butts

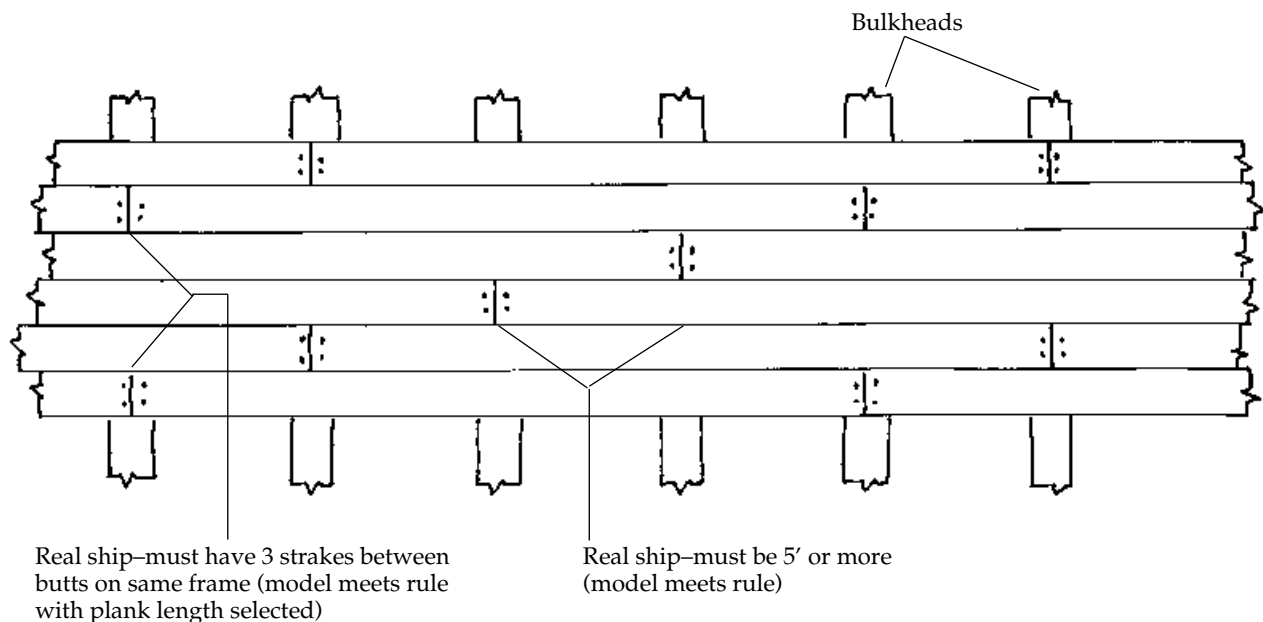

modeler. However, by using shorter pieces there are some advantages. Since all planks taper to some degree, using the shorter piece will let you mark the taper quick, and the plank will be easier to fasten in place. And with a short piece, only one hand is necessary to hold it down. Also, if you make a mistake, you only have a small piece to do over. So, the following is based on the use of the shorter lengths.

Planking butts will not be exactly like a real ship. Because the model is built on the bulkhead system, planking butts must occur on bulkheads.

Use a plank length to cover four bulkhead spaces. This is a comfortable length to handle for this model; about 5" to 6". To scale, that's a plank 27 to 32 feet long. However, to avoid having very short pieces at the bow and stern, you may need to use a longer or shorter plank to complete the run.

To follow real ship rules, you should stagger the butts on the model (see figure 19 for a sequence that is similar to a real ship). The stagger also applies to the deck planking. The plank covering four bulkhead spaces works well with the rules. With this length you can meet the rule for three full plank widths between butts on a single frame. If you use a plank length to cover only three bulkhead spacings, this would not be possible. Since the butts occur on bulkheads,

you would wind up with only two full planks between the butts.

4. Spiling

Edge bending planks on a real ship is done, but it is limited. The wood is very stiff, so many planks must be cut to shape. Spiling is the term used for laying out the cuts (see figure 20). It's simply a matter of transferring curves to a straight plank, then sawing the plank to shape. For the *Rattlesnake* model, any stealers required are shown on the planking layout. For most narrow planks, the basswood strips are flexible enough so they can be edge bent in place.

5. Fastening the Planks

There are some fancy plank clamps on the market, but they are more trouble than they are worth. They must be screwed into the edge of the bulkheads, leaving a big hole to contend with when doing subsequent planks. With short pieces, you can hold or pin the planks in place. Be careful not to split the plank with the pins. If necessary, drill a small pilot hole first. Glue each plank to the bulkheads, and edge glue them together. For the edges, use white or carpenter's wood glue so the setting will not occur too fast. At the bulkheads, it is good to use thin super glue to quickly secure the plank in place, but be careful not to glue your fingers.

While glue alone will hold the planks, you may wish to use small brass brads or wooden treenails for additional holding power, or just for looks. Use fine brass brads and cut off and discard the heads, then hammer the shaft in. If treenails are desired, you can buy them commercially. Better yet, get some long bamboo skewer sticks, strip off small pieces, then pull them through a draw plate until you have very small dowels. Drill holes for the "treenails", add a touch of glue, and drive them in place. Treenails are good if you want to add them where each frame would appear on a real ship.

6. Planking the Outer Hull

Belt Layout: Now the fun begins! From the upper rails down to the top of the wale, the hull is divided into fairly even spaces from bow to stern. The rails and wale line are all *Rattlesnake* pre-set lines which cannot be modified. At the quarter deck, from the cap rail down to the covering board, the bulwarks are planked with five planks. Below the covering board there is a single plank, then a plank covered with a molding strip. This strip goes from bow to stern. Below the molding strip, down to the top of the wale there are seven planks, all about equal in width from bow to stern.

The plank layout above the wale is based on the layout developed by Mr. Campbell and shown on his plans. As an option, you could make the planks

FIG. 20 - Spiling

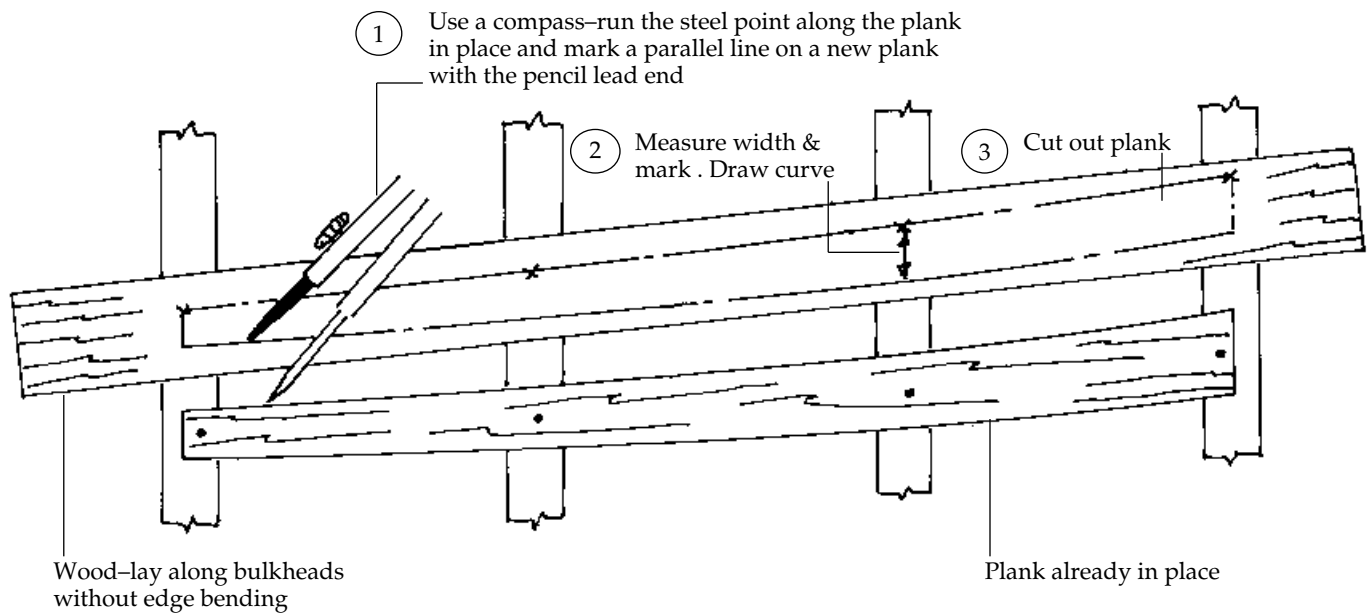

wider. For example, use five instead of seven planks below the molding strip.

From the top of the wale down to the keel, all planking will require tapering forward and aft. Consequently, the hull below the wale has been divided into three belts; **BELTS A** through **C**.

On this particular ship there is no "lower" edge to the wales. The thicker wales gradually taper into the planks below so you do not see another step along the hull like some other ships.

Note: On George Campbell's plan you will see a note and sketch advising you to cut into the hull to show the wale line. This was for the older solid hull model. With the P-O-B model, the difference in the 1/32" and 1/16" plank provides the wale step.

From the Hull Planking Layout drawing, use a tick strip along each bulkhead location and mark the top-of-wale location and the belt seams below. Using a tick strip, transfer the location of the seams on each bulkhead and mark with a pencil. Now, using 1/16" x 3/32" temporary bass-wood battens, lay the battens along the marks and temporarily tack them in place.

The purpose of the battens is to assure an accurate flow of the planking belts. Although the Hull Planking Layout was developed in the same manner, errors in drafting and tick strip marking and transferring may occur. With the battens actu-

ally in place, these errors can be corrected. However, remember that the wale line is a given and must follow the plans.

With all the battens in place, visually check the flow of the battens. Look at the model from the side and from the bow and stern. Do they look like nice smooth curves? Adjust the lower battens if necessary. The plans (see also figure 21) show what they should look like from the side and ends. When everything seems OK, if necessary, remark the belt seam lines on the bulkheads. Make sure that all the belt seams are clearly marked. You do not want to lose them. You could now remove the temporary battens or leave them in place until they need to be removed in order to add a plank.

Sloping Plank Edges: As you proceed with the planking, you may need to slope the edges of a particular plank so it butts flush against the adjacent plank.

To begin with, all the planks on the hull have square edges. When butted against each other on a round hull form, a small gap may appear between each plank. Most of the gaps will be filled with glue, or you can fill them with wood filler. On a real ship, the gaps are eventually caulked. In fact, the edges of the plank are often sloped to increase the gapping. This measure assures that the inside of the planks butt against each other, and that on the outside there are sufficient gaps for caulking. If you want a perfect-

ly smooth hull without the gaps, you must trim the edge of each plank as you fit it. A lot of work, but your decision.

Planking the Counter: Plank the counter with 1/32" planks. Let the counter planks extend outboard for now. When the hull planks are installed, the hull planks will be fitted against the counter in a miter (see figure 22).

Planking Above the Wale: From the top of the wale up to the rails, all the planking is 1/32" thick. The planks are fairly uniform in width from bow to stern and can be fitted rather easily. Do not plank over the gunport or oar openings.

The fancy molding strip can be added on top of a hull plank, or a single piece may be used instead. This option is shown on the plans. It is probably easier to add it separately so you can sand the hull before gluing on the molding. The same goes for the quarter deck covering board strips outboard.

Laying the Planks in Belt A: Each belt of planking is done separately. Consequently, you can start with any belt. For discussion, let's start at the top and work down. **Belt A** has six 1/16"-thick plank strikes below the wale. The maximum plank width is at **Bulkhead G** and is roughly 10" real ship width (about 5/32" model scale). The planks taper forward to about 3/32". Going aft the planks get wider to about 3/16". Use the 1/16" x 3/16" strips for the planking in this belt.

FIG. 21 - Belt Battens

 Look for smooth flow of battens

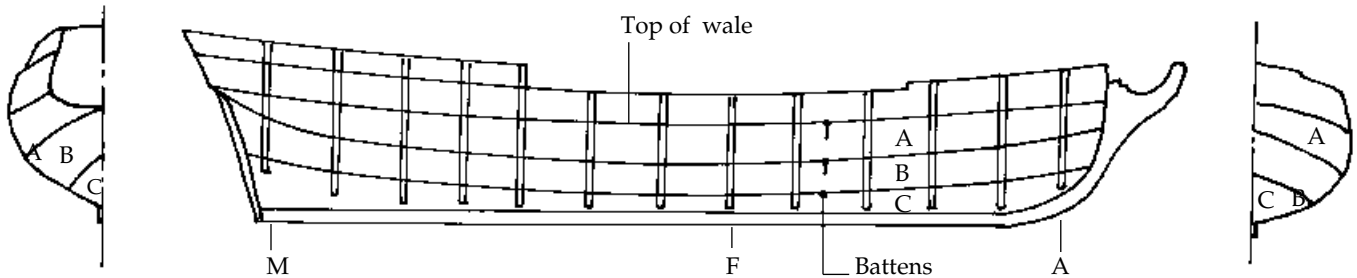

Use a tick strip and lift the plank widths from the Hull Planking Layout. If you have changed the locations of the battens, simply divide the space into six equal plank widths at each bulkhead. A set of proportional dividers would help. Mark these lines on the bulkheads with a pencil. You should now have a completely marked area for **Belt A**.

The next step is to cut planks to fit between the marks. **Belt A** will not require spiling, so a straight tapered plank can be made. Start at **Bulkhead G**. Use four planks, one from **Bulkhead G** to **Bulkhead K**, another from **Bulkhead K** to the stern, **Bulkhead G** to **Bulkhead C**, and **Bulkhead C** to the stem. First, lay a piece of planking material over the bulkheads and mark the length. Mark the plank in pencil at each of the bulkheads. Next, use a set of dividers or a tick strip and lift the plank widths from the marks on the bulkheads and transfer to the plank. Draw a line through the points and cut the plank. You should now have a tapered plank. Trace this plank to obtain another one for the other side of the hull.

Install the planks on the hull. Do the same process for the next strake below. Stagger the butts for this strake. Install a plank from **Bulkhead F** to **Bulkhead B**, **Bulkhead B** to the stem, **Bulkhead F** to **Bulkhead J**, and **Bulkhead J** to the stern. You will have four planks making up each strake from bow to stern (see figure 23).

FIG. 22 - Planking The Counter

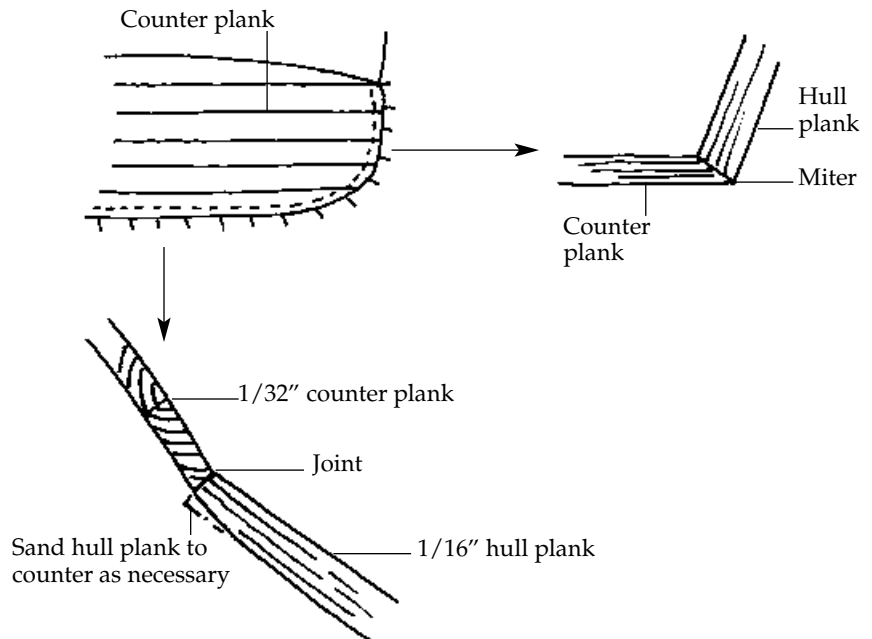

Now, move down to the next planking strake and work it the same way that you did the previous one. Stagger the plank butts, starting at **Bulkhead E**. Continue until this strake is finished, then complete the other strakes in **Belt A**. At the stern, most planks will have a severe bend. These planks must be steam bent.

Laying the Planking in Belt B: This belt is very similar to **Belt A**. It also has six plank strakes about the same width as those in **Belt A**. If you have not removed the temporary batten, do it now. You can now start the process for **Belt B**, but remember to stagger the butts.

Laying the Planking in Belt C: This belt contains the garboard strake (next to the keel). At **Bulkhead F**, the planks are slightly wider than **Belt B**, but taper and expand forward and aft similar to **Belt B**.

The shape of this hull is such that no stealers are required in any belt. Although the planks get wider aft, their width without stealers is still reasonable, about 12" full ship size.

The P-O-B plan has a complete planking profile shown. Use this drawing to determine the plank widths in **Belt C**. The sections of the Hull Planking Layout drawing cannot show all the planks aft so the profile view is necessary.

Plank Variations within a Belt: Suppose you are working within a belt, and have five planks the same width, and then find that the last plank in the belt must be made wider to complete the belt....should you worry? Certainly not. No planking job, even on real ships, is that precise. You are dealing with hand-cut planks. The important thing is to keep the flow of planks smooth. A variation in plank widths within a belt is of no great concern. Even though this kit provides a planking layout, you must be realistic. There are going to be some slight variances as you proceed.

7. Planking Inboard (Ceiling Planks)

Plank the inboard side of the gun deck level, and the quarter deck bulwarks with 1/32"-thick ceiling planks (see figure 24). The ceiling can be omitted on the gun deck at the officer's quarters, since the area cannot be seen when the model is completed.

Option: You could do the ceiling plank before you do the outer hull plank. The sequence is optional.

8. Planking the Decks

Special Note: You probably noticed that this model is designed so that the officer and captain's quarters on the gun deck is

FIG. 23 - Belt "A" First & Second Strakes

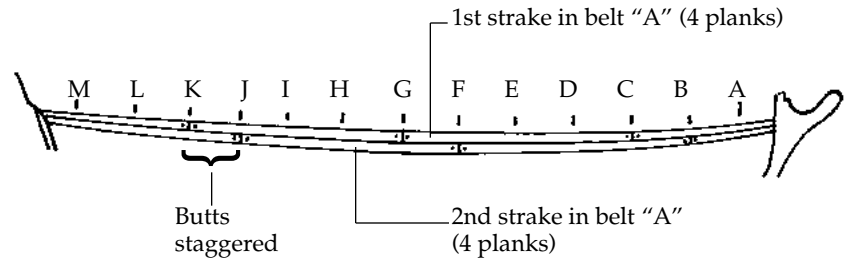

not detailed. If you wish to detail this area, some modifications must be made to the bulkheads and a full deck planked. For our kit, the area is not detailed, but it still contains some cannons. If you use a full cannon, add a section of decking to the quarter deck using 1/16" sheet wood as shown on the P-O-B plan. The plan also shows a detail of an optional dummy cannon barrel so you can eliminate the decking if desired.

Before installing the quarter deck planking, add the cannons or you will not be able to get to them later to do the necessary fitting. Make sure they are securely fixed in place. It would be a disaster to have a cannon come loose later.

Hatch & Grating Coamings: Before planking the deck, you must decide how you want to treat the grating coamings. To do it like the real ship, and a recommended approach, install all coamings first. You can then plank around the coamings. This saves some planking work and material. On the underside of the coamings, insert some scrap wood so the deck plank has a support for gluing (see figure 25).

If you elect not to install the coamings now, the coamings along with the completed hatch and grating can be glued down on top of the deck planking.

Deck Planks: All deck planking is 1/16" thick. The actual run of planking is shown on George Campbell's hull plan. Notice that the planks run more or less parallel to the shell rather than the centerline. Planks can be edge bent some, but you may need to use the spiling process to complete all deck planks.

After the deck planks are shaped, prepare the strips by painting one edge black or dark brown. When the planks are glued together, this will simulate caulking in the seams. You can also use a brown colored carpenter's wood glue on the edges of the planks. When dry, this glue is dark enough to simulate the caulking.

Thick Pads: There is a thick pad on the deck under the galley chimney. Use a 1/32"-thick piece as a doubler on top of

FIG. 24 - Inboard Planking

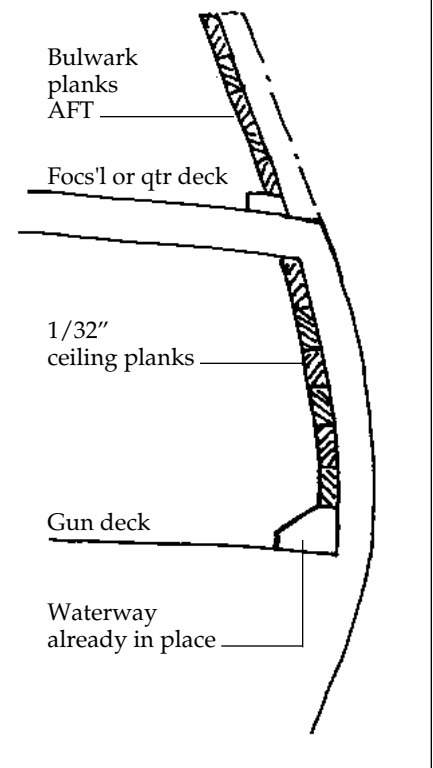

the deck. The hole for the chimney should be cut through the doubler and deck planking.

Procedure: Start deck planking at the centerline and work outboard. Where nibs are located you can insert a piece of scrap under the plank for support (see figure 26).

Scrape off any glue squeeze-out before going to the next plank. Planking butts can be used, like the outer hull, or they can be omitted. On the real ship, they do not show up as readily as the seams. You can also scribe butts after each plank is laid. Since there is no cutting or curves involved like the hull planking, using long deck strips is no problem. Use brads or treenails if you like. See Hull Plank discussion.

STAGE C

COMPLETING THE BASIC HULL STRUCTURE

1. Correcting and Sanding

After all the planks are installed, look over the entire hull. If you find seams with starved glue joints, rub some wood glue in the cracks and, if necessary, add some wood filler. When seams are filled, sand the entire hull and deck planks smooth.

2. Building the Head Rails

The head rails are tricky little devils, but easy once you grasp what they look like. Cut all the parts from wood. There are no laser-cut parts in the kit. The various parts and how they go together are illustrated (see figure 27).

3. Gunport Lids

Notice that there are no gunport lids in the midship area, only forward and aft. The gunport lids are supplied as Britannia fittings or you can make them from wood. Use 1/32"-thick wood. Make the hinge straps from brass or paper strips.

4. Building the Gangways

From the quarter deck to the forecastle, outboard side, there is a portion of fixed and portable gangways. All gangways sit on iron knees. For the model, these can be made from wood (see figure 28).

5. Natural Wood/Double Plank Option

Most wooden ships have single thickness planking. Furthermore, the kit is intended to be painted. However, many modelers are familiar with the European double-planked kits, or want to have a natural wood tone finish on the hull, typical of the Admiralty type models. Also, after the planking job is completed, some modeler's wish to try again to improve the looks of the job. If this is your desire, the model can be double planked over the basswood planking.

Thin wood strips in mahogany, walnut, and some other types of exotic hardwood can be purchased from Model Expo for the task. For the *Rattlesnake*, you will need about 75 strips which are 0.5mm x 5mm x 20" and includes about 20 percent increase for waste and errors.

FIG. 25 - Hatch & Grating Coamings

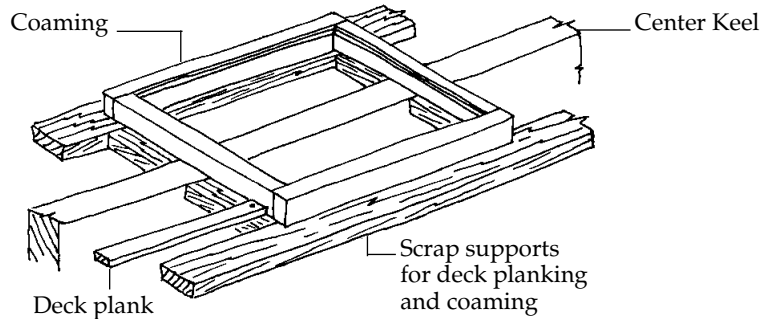

FIG. 26 - Nibbing The Deck Planks

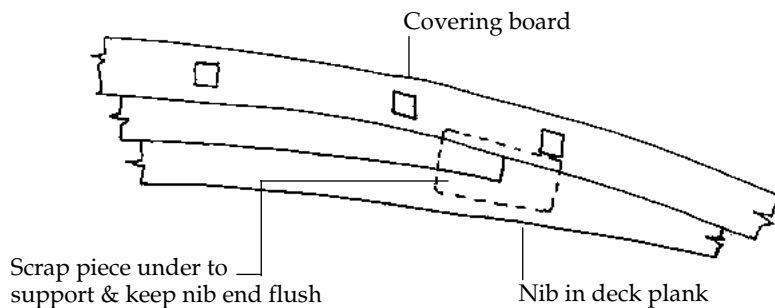
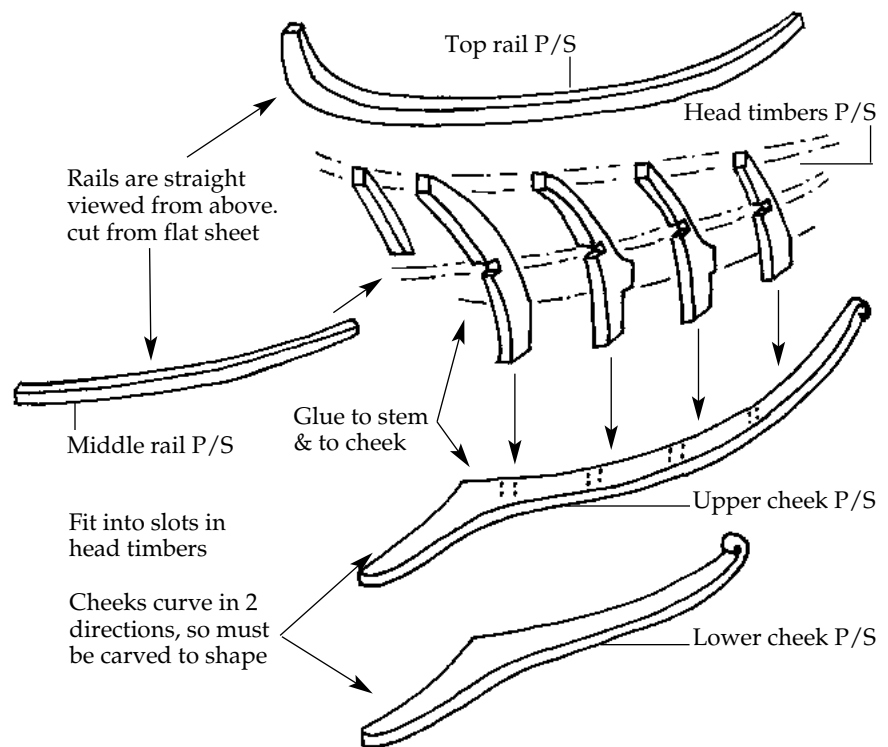

FIG. 27 - Building The Headrails



The natural wood planks will cover the existing planking, but you will still have the rails exposed. You could substitute these initially with the wood of your choice, cap them with the strips, or simply stain them to look similar.

When applying the strips, proceed exactly as you did for the basswood planking process. You may want to work with longer strips since the basswood planking already defines the plank shapes. Simply lift dimensions from the hull and cut the natural wood strips. When completed, sand and finish the hull with Floquil oil, glaze, or tung oil. Finally, add a coat of wax and polish.

STAGE D

MOUNTING THE HULL

Before proceeding with additional work it is best to mount the hull. This step will help prevent details from becoming damaged while you handle the model. It will also allow you to make any alignments that require a true waterline. So, proper mounting of the hull is very important. While any modeler can devise his own mounting, this kit contains two brass pedestals and a baseboard for mounting the model. A second option, called the launching ways, may be made by hand or purchased commercially, as well.

If you intend to put the model in a glass or plastic case, you could make the bottom of the case serve as a baseboard.

1. Mounting Board with Two Pedestals

Round the top edges of the kit-supplied baseboard, or cut a simple chamfer. If you own a router, or can borrow one, you can cut some fancy shapes on the baseboard edge. Paint or stain the baseboard. You can buy a pre-finished baseboard if you like or make your own from a more exotic wood like cherry, walnut, bubinga, or rosewood.

Mount the model so the load waterline is parallel with the baseboard. On *Rattlesnake*, the load waterline is not defined by a painted horizontal bottom line. The bottom color goes up to the black stripe which is parallel to the wales and is a curve. Consequently, you must use the hull plan to determine the height of the load waterline at each end of the model.

Drill pilot holes in the model and baseboard for the pedestal screws. If something goes wrong and the balance is off, add a brass shim under one pedestal to correct it.

FIG. 28 - Building The Gangways

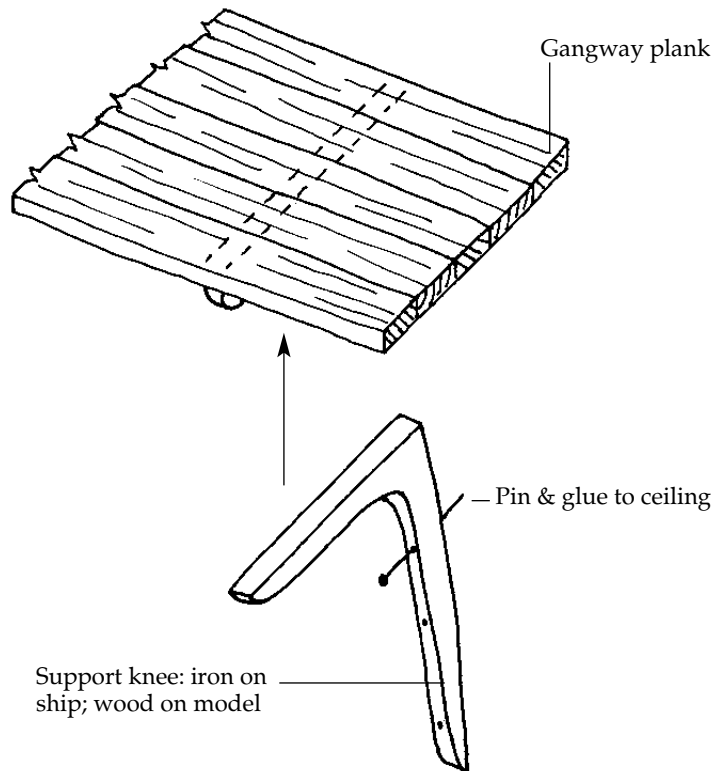
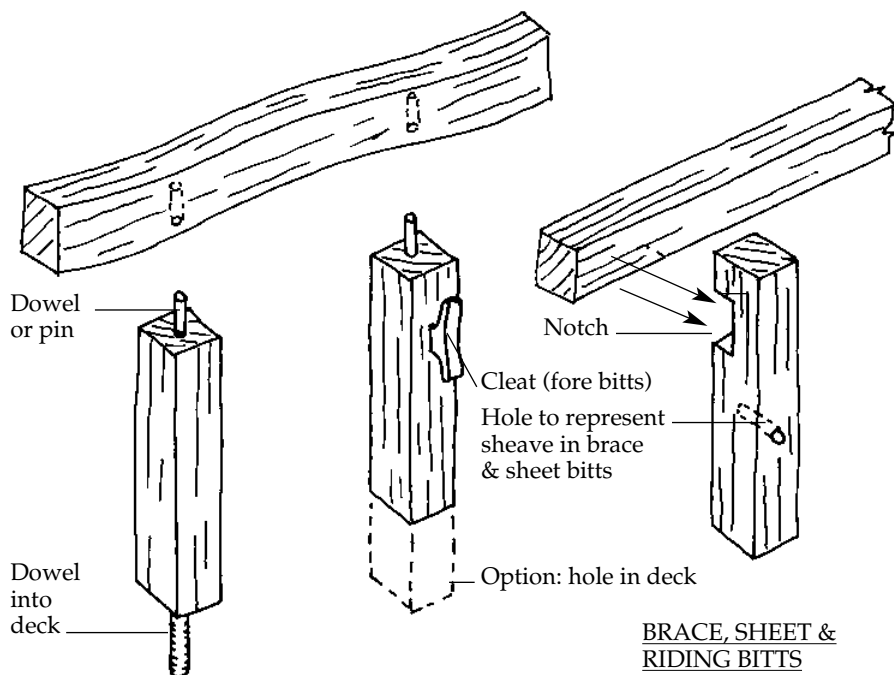

FIG. 29 - Making The Bitts From Wood



TYPICAL GALLEYS BITTS

2. Launching Ways

The second type of mounting that can be employed is the launching ways (or building ways). This mount is most suitable for models without sails. It is supplied in kit form with instructions. Drilling of the keel is still required to apply the rods that anchor the model to the ways. The launching ways are easily assembled for mounting on the baseboard. If you use a larger baseboard, this would allow you to create a mini-diorama comprised of boat yard ground activity. Follow directions supplied with the ways to achieve the proper waterline level.

Note: It is recommended that either choice mounting piece be finished before mounting the Hull Assembly into place.

STAGE E

ADDING THE HULL DETAILS

1. Locating Deck Fittings & Structures

If you included any hatch coamings when planking the deck, you should at least have those structures located by now. Now it is time to locate all the other items that must be added. This includes items such as the galley chimney, elm pumps, binnacle, capstan, gallow bits, fore brace bits, riding bits, topsail sheet bits, catheads, cleats, eyebolts and ringbolts, chesstrees and kevels, and quarter badges.

To locate items, measure from some known bench mark such as the center of a mast, or from the centerline. Mark all locations lightly in pencil.

Fittings such as eyebolts and cleats associated mostly with rigging can wait until later. However, it is not a bad idea to get all these fittings installed while working on the deck. Get them done, then clean up and varnish the deck. Then, when you start the rigging, all of those fittings will be waiting and ready to use.

2. Topsail Sheet Bits, Fore Brace Bits, Riding Bits & Gallows Bits

All of the bits are supplied as Britannia fittings. As an option you can make them from wood as shown (see figure 29). They can be attached to the deck with a dowel or by cutting a square hole in the deck as shown in the sketch. In any case, make the attachment secure. Some of the bits will have stress from rigging lines belayed to them.

FIG. 30 - Ladders

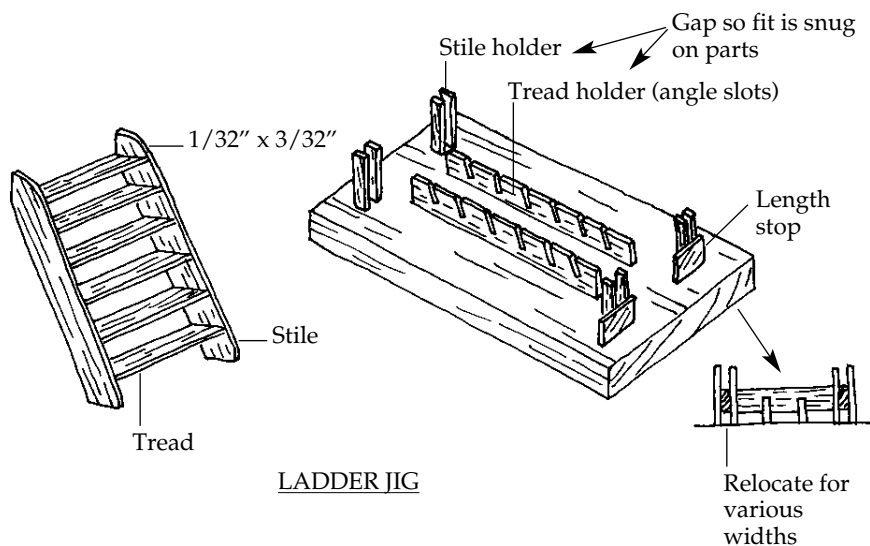

3. Ladders

The ladders are supplied as Britannia fittings, but can also be made from wood (see figure 30). The ladders should be made from 1/32" thick wood strip which is 2" full ship size. Actually, you could even sand this down a little thinner. Delicate ladders look real nice on a model. A jig, shown in the sketch, can be used to keep the parts in line while you glue.

4. Hatches & Gratings

If the coamings are already done, then complete the details (see figure 31). Add the ladders where appropriate and make the gratings. The grating material is supplied laser-cut in the kit so a lot of work has been eliminated for you.

Notice that the grating strips can be assembled in two ways. The edge-to-edge gluing option makes the grating thinner and more realistic. It also fits in the hatch better and the ledges need not be so deep.

5. Binnacle

This is a simple old time box binnacle, typical of the period. It can easily be scratch built from wood as an option, but is supplied in the kit as a Britannia fitting (see figure 32). Add the chimney to the fitting or leave as is.

6. Capstan

The capstan is also supplied as a Britannia fitting, but looks much nicer if scratch built from wood (see figure 33). The capstan is double on a single shaft, but each capstan is keyed so they can operate separately. The upper capstan is on the quarter deck and lower on the gun deck in the officers accommodations. You can't see the lower capstan unless you leave a door open, so you can omit it if desired.

7. Catheads & Anchors

The hull plan shows a cat tail beam under the deck supporting the cat head. Since this cannot be seen, it can be omitted on the model.

There are two anchors, supplied as Britannia fittings in the kit. You can substitute scratch-built wood stock for a more realistic look.

The anchors are hoisted from the sea by the tackle in the catheads. They are then secured to the hull by the cat stoppers and the shank painters. The tackle can then be unhooked and the blocks brought inboard and stowed. There they are stowed and ready for quick release when needed (see figure 34).

FIG. 31 - Hatches & Gratings

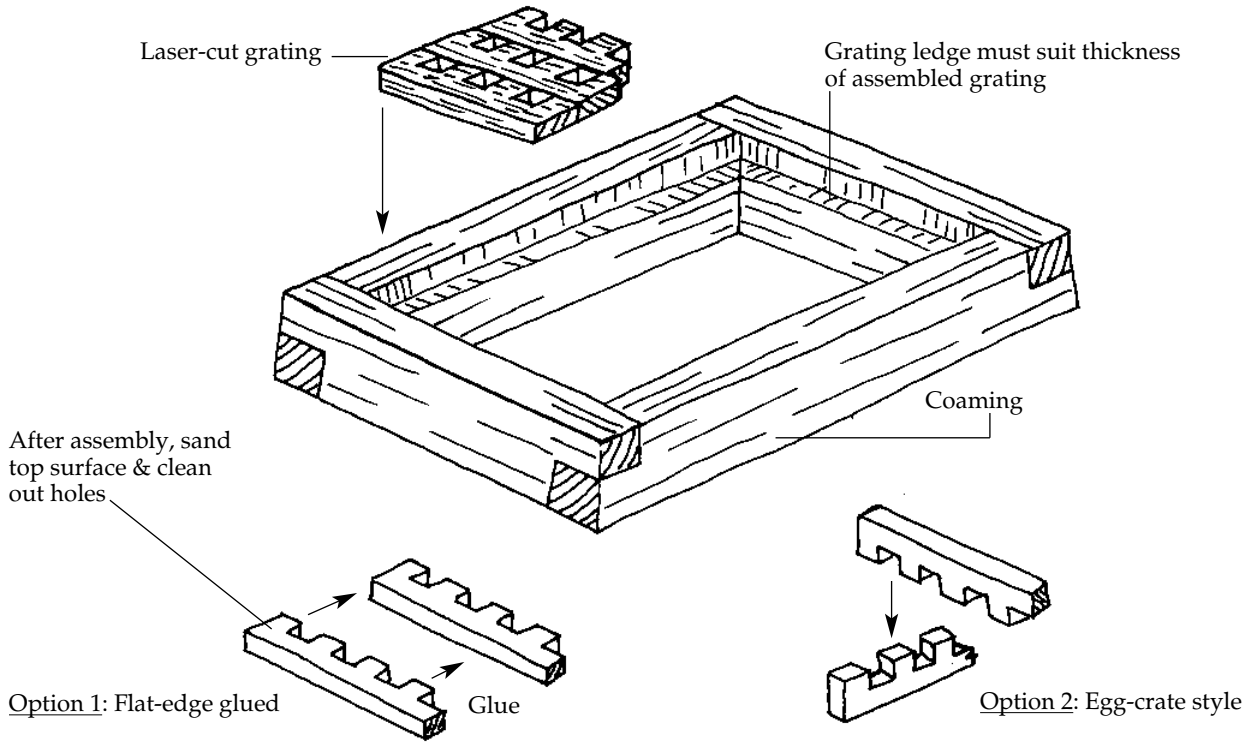

FIG. 32 - Binnacle

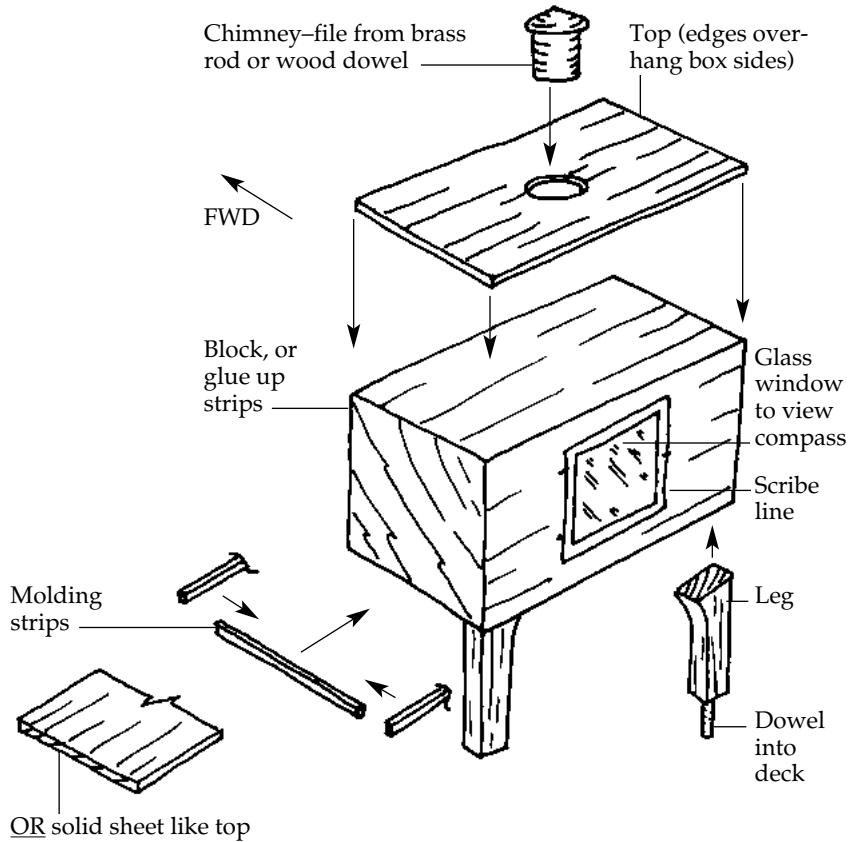

FIG. 33 - Capstan Details

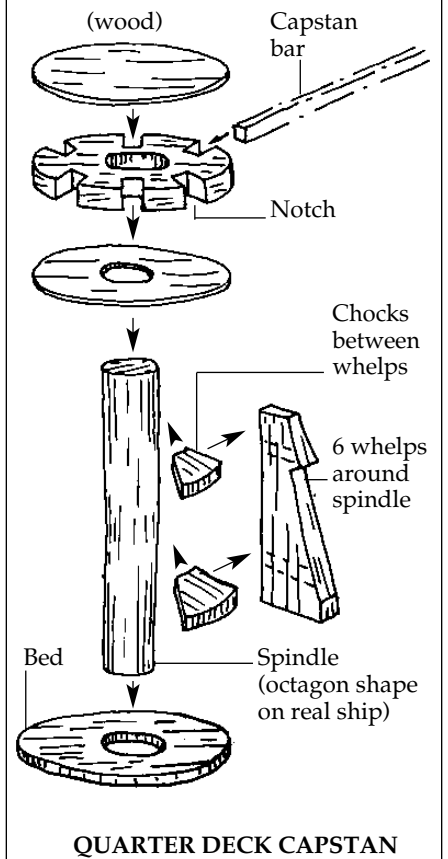

FIG. 34 - Catheads & Anchor Details

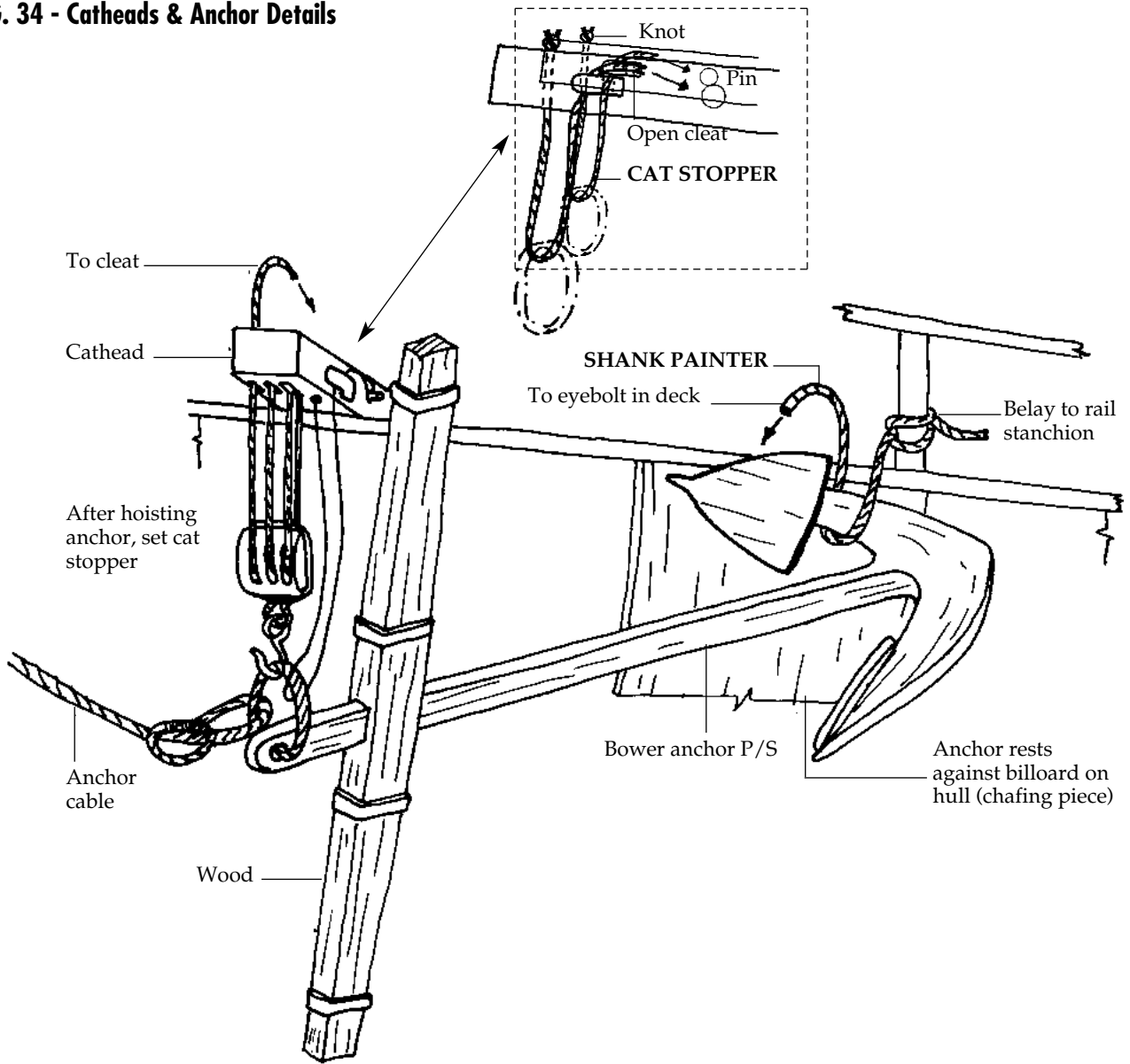

FIG. 35 - Elm Pumps

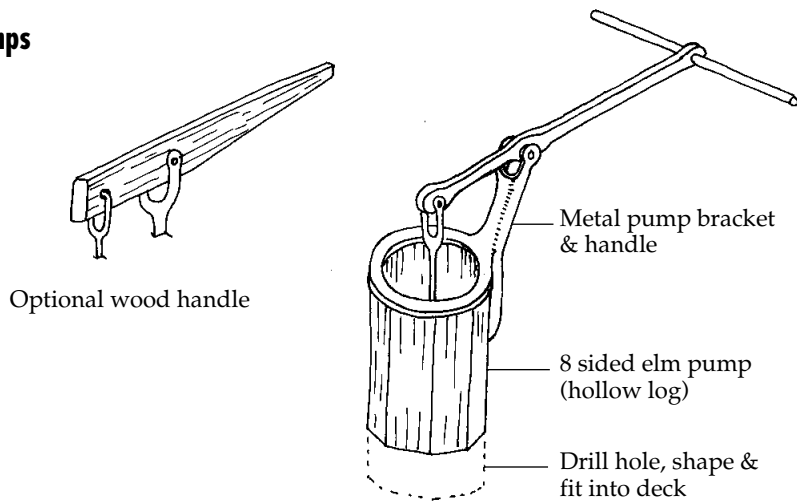
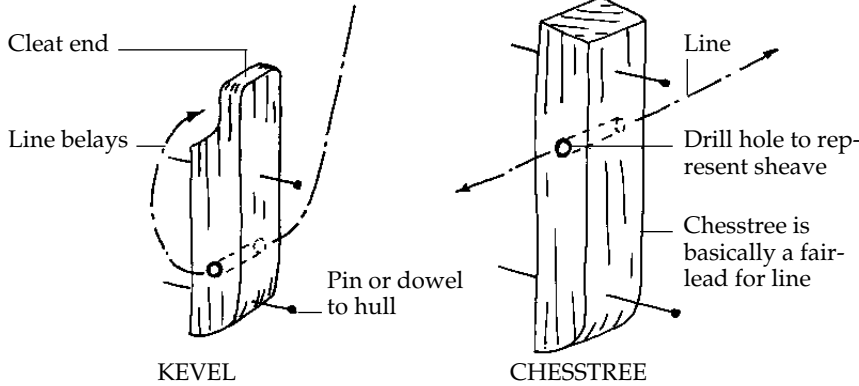

FIG. 36 - Kevels & Chesstrees



8. Elm Pumps

The pumps are supplied as Britannia fittings (see figure 35). Drill holes in the deck and insert the pump fitting. The pump body is a hollowed-out log. The plans show a metal bracket and pump handle. However, on some early ships, the pump handle was a simple wood handle, an option shown in the sketch.

9. Kevels & Chesstrees

Use wood strips to make the kevels and chesstrees (see figure 36). Although these are rigging items, it is best to make and install them now. You need not put actual sheaves in the pieces. Simply drill a hole for the rigging line as shown in the sketch. The pins are a good idea because the parts may come off if not fastened securely.

10. Galley Chimney

The chimney, or call it a galley stack, is supplied as a Britannia fitting. It has what apparently is a thick pad around the chimney as it passes through the deck. Since this is not defined in the Campbell plans, it is suggested you add a 1/32"-thick piece on top of the deck (see figure 37).

Just forward of the chimney there is a steam grating. This allows the vapors from the galley stove to vent. Use a typical laser-cut grating in this coaming.

11. Channels

The channels can be made from wood strip and installed now, or wait until you make the chain plates. Consult Stage H for chain plates and channel details.

12. Deck Buckets

The buckets and racks are supplied as Britannia castings, but if you want to have some fun, make them out of wood (see figure 38). The racks fit between the breast rail stanchions on the quarter deck. There are six buckets in all. The buckets should have rope handles, but this small detail could be omitted on the model.

13. Eyebolts & Cleats

The location of all the eyebolts and cleats for rigging are shown on the hull plan and the rigging plan. The kit has a sufficient number of metal cleats and eyebolts. You could make your own cleats out of wood but they are rather small. Since there will be some strain on these items from rigging, they must be secured firmly. Drill a small hole through each cleat and insert a brass wire or pin. Drill a hole in the deck or wherever required and insert the eyebolt and cleat pin. Use some super glue on a toothpick and touch the glue around the eyebolt and cleat to secure it. Careful, not too much glue. After it is dry, tug on it to see that it will not come out. The eyebolts are simply a wire bent into a loop. If you want to close the loop, touch with a little solder or epoxy glue.

14. Rudder & Tiller

The rudder is a laser-cut piece but needs to be shaped according to the plans. The pintles and gudgeons should be made from brass strip, or if you dislike brass you could use paper strip. After installing the rudder, make the tiller from wood strip and insert it in the rudder stock (see figure 39).

FIG. 37 - Galley Chimney

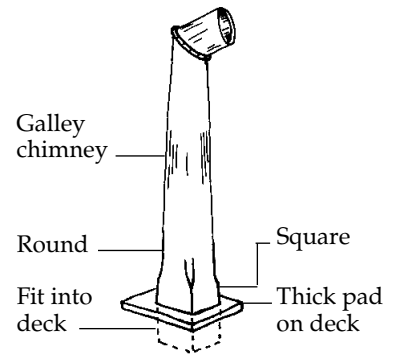

FIG. 38 - Deck Buckets

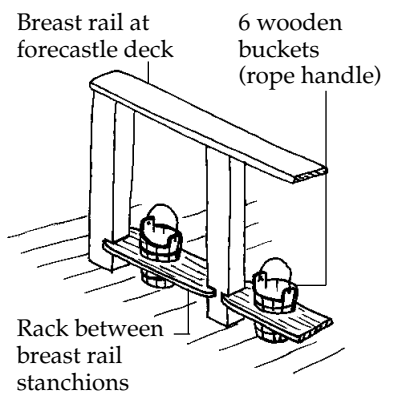

FIG. 39 - Rudder & Tiller

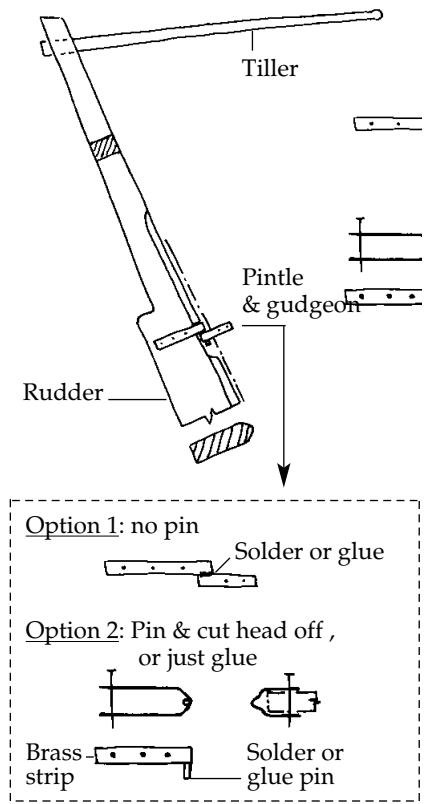
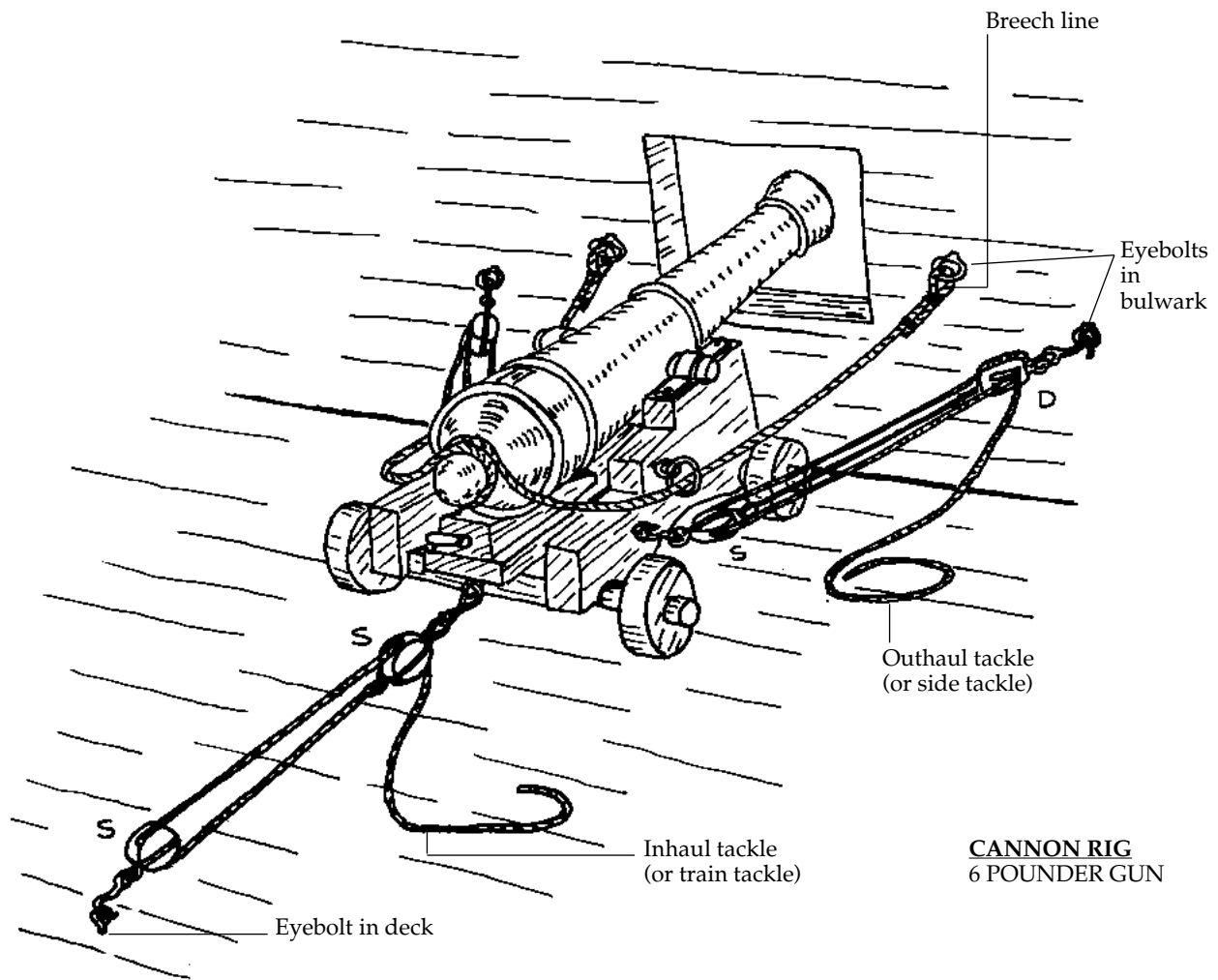

FIG. 40 - Cannons



15. Quarter Badges

A separate Britannia fitting is supplied for the port and starboard quarter badges. Drill a hole at the top and bottom of each quarter badge so you can insert a pin for mounting and gluing them to the hull. Fit a piece of acetate in the window and paint the back either pale blue for a reflective window or black to fake a window area. There is no actual hole in the hull where the window goes. The interior is not detailed in this area anyway and the casting fits directly on a flat surface.

16. Cannons

The *Rattlesnake* has 20 gun ports, but probably carried only 18 guns. The two forward gun ports are too confined for a gun. These ports were probably used for line handling rather than for guns. The guns carried were 6 pounder cannons. The kit provides 10 gun kits with brass barrels and wood carriages. You can rig the cannons at the open gunports on the gun deck as shown (see figure 40). If you wish to add guns at the other gunports, which have lids, the extra guns can be purchased separately, or you can buy dummy gun barrels and mount them in the open ports.

Cannons inside the officer's and captain's staterooms need not be rigged since the rigging cannot be seen. These cannons should already have been installed before you completed the quarter decking as mentioned in Stage B. If you use a dummy gun barrel in the officers' quarters, you can eliminate the deck plank areas required for a full gun as shown on the P-O-B plan.

FIG. 41 - Ship's Longboat

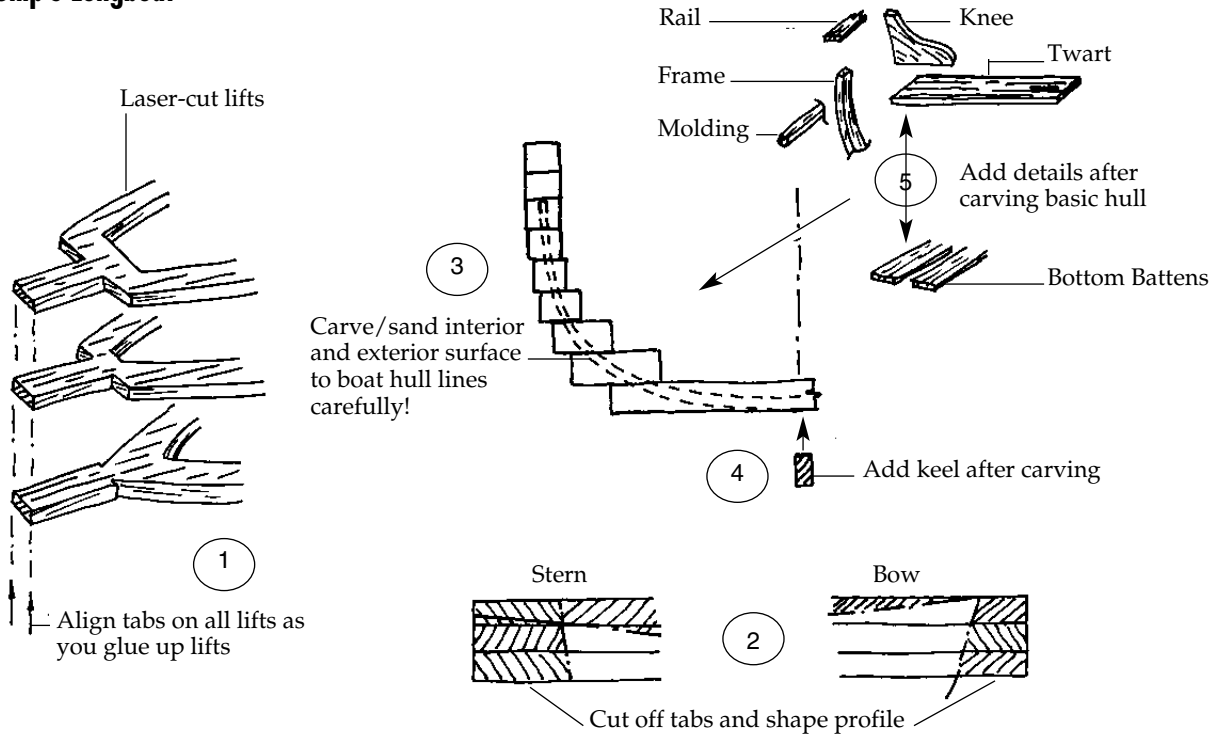

17. Ship's Name

The *Rattlesnake* name should be lettered on the surface of the stern. The neatest way to add this detail is to use dry transfer letters. These can be purchased at a number of art or office supply stores. After applying the lettering, paint over the letters with a coat of flat varnish. You can also find decal lettering from model railroad stores.

18. Ship's Longboat

The ship's longboat model is unique. Instead of the usual Britannia casting or solid block boat found in most kits, this kit has laser-cut wood lifts for bread-and-butter construction (see figure 41). You will be doing some carving, and will be faced with a challenge: how thin can you carve the hull without breaking it?

Carving a small boat hull is difficult. A way to check the thickness of the hull is shown (see figure 42). This is a homemade double-ended caliper. You can also buy metal ones commercially. There are end tabs on each lift to assist with the alignment. The wide tab is the stern and the narrow tab is the bow. Each lift from tab end to tab end is the same length. As you glue up the lifts keep the tabs in line. Use only a thin coat of glue. If you get too much glue on each lift, the thickness will accumulate and the overall height of the glued-up lifts will be too great.

FIG. 42 - Homemade Caliper To Check Hull Thickness

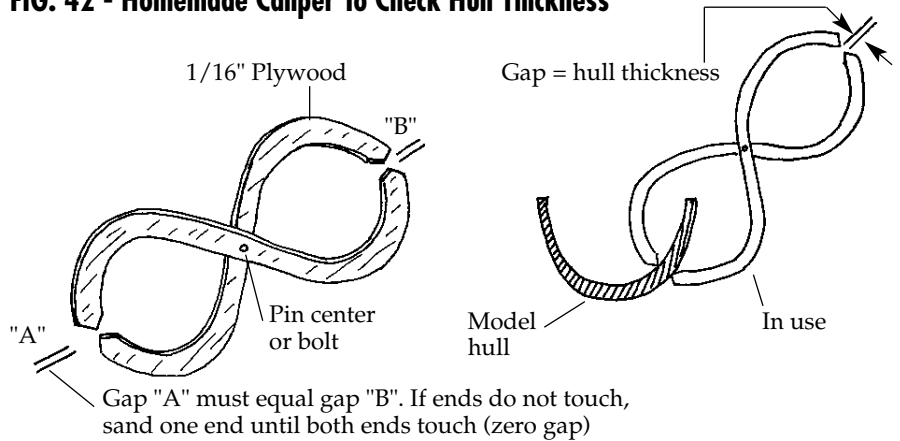

Carve the inside of the boat first using chisels and sandpaper. Carve or sand the corners of the lifts down to the intersection of two lifts. When all is smooth, the shape should be reasonably correct. Next, cut off the tabs and carve the hull to the correct profile. Then carve or sand the outside form. Be careful; the hull will be getting thin. Make some templates from the body lines shown on the plans to get the shape correct. Add the keel and rudder and you will be done with the basic hull.

Carving Option: It may be easier to carve the inside of the boat hull by temporarily leaving off the bottom lift. Carve the inside close to what is required, then glue on the bottom lift and complete the carving.

How far you want to go with detailing is up to you. You can add bottom boards, frames, thwart knees, and gunwale molding. All these details add to the model, but will be a little difficult. If you do it, always keep the scale in mind. This is a delicate boat. Make the thwarts 1/64" thick (sand down a 1/32" piece).

STAGE F

MAST & SPAR CONSTRUCTION

At this point, your model should have a considerable amount of stuff on board. Take another look, correct mistakes and touch up paint blemishes. Go over the plans again. Did you miss anything? When all looks well, get ready for the masts and spars.

1. The Importance of Scale

While the scale of masts is important, the yards and gaffs are probably the most critical spars to consider in regard to proper scale. Stubby, fat-ended yards stick out like sore thumbs, giving a model that unprofessional look. Care should be taken to assure that yards are tapered properly and to correct scale. It is sometimes difficult to taper a small yard, because breaking the yardarm is always a risk. However, the amount of time and effort spent making a yard is worth the investment when the end result is an overall appearance which is pleasing and scale-like.

2. Shaping & Tapering the Masts & Spars

The hull plan and the rigging plan show all the masts and spars to scale. The kit provides round dowels for masts and spars, but final tapering to the shapes shown on the plans is still required. A dowel is difficult to taper since it is already round. The best approach is to slice the dowel from a round shape at maximum diameter to a square shape at the ends, then to an eight-sided shape. Final rounding is achieved by sanding. This approach prevents a round dowel from becoming an oval (see figure 43).

Although a little tricky, you can also taper a dowel by chucking it into an electric drill or lathe. As the speed of the drill turns the dowel, use sandpaper to shape the taper.

Many experienced modelers like to discard the dowels and make masts and spars from square stock. The advantage: you use a wood of your choice and marking tapers is easier. It also permits including square or octagon sections in the spar without adding any wood to build up the diameter. See the discussion that follows.

Variations in Diameters: The mast heads, the topmast and topgallant mast heels, and centers of the lower fore and main yards are square or octagonal in shape. The distance across the corners of the octagon or square is greater than the

FIG. 43 - Shaping The Masts & Spars

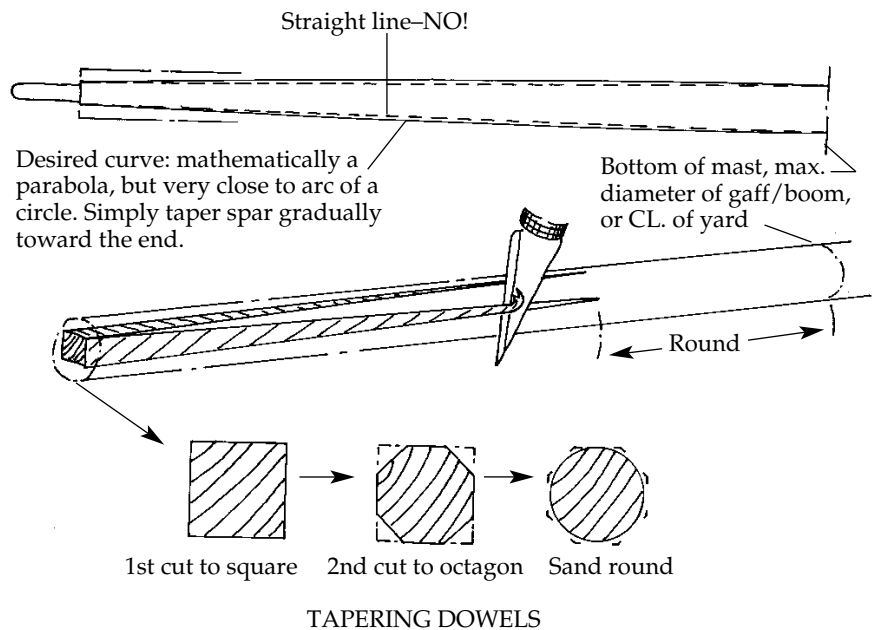

round part of the mast or spar, or in the case of the model, the supplied dowel. If you want to shape the spars correctly, you must first add some wood in these areas to increase the diameter. Then you cut the octagon or square, and it will flow smoothly into the basic diameter (see figure 44).

If you do not want to add wood, you had better leave the spar round. If you cut the octagon, it may make the spar diameter too small.

3. Building & Installing the Masts

After squaring the heads to the proper width, cut the tenon (or tongue) at the top. Then cut the square head into an octagon shape as shown on the plans (see figure 45 for some detail at the mastheads).

The heel of the topmasts and topgallant masts have a rectangular or square hole. Drill a round hole and shape it up with a file. The hole will hold a fid which prevents the mast from falling through the top. A fid is nothing more than a stick of wood, but they can have various shapes (see figure 46 for fid hole positioning and a couple of simple fid shapes).

After the basic masts are completed, drill any holes required to represent sheaves in the masts. You do not need to install actual sheaves. They would be covered by the line anyway.

FIG. 44 - Spar Diameter Build-up

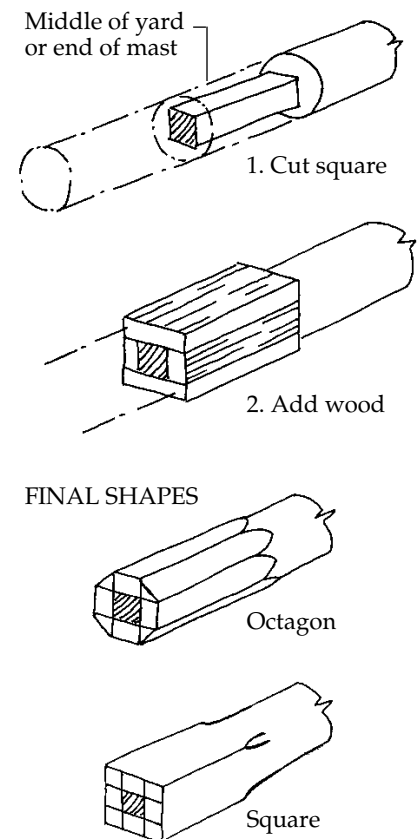

FIG. 45 - Masthead Details

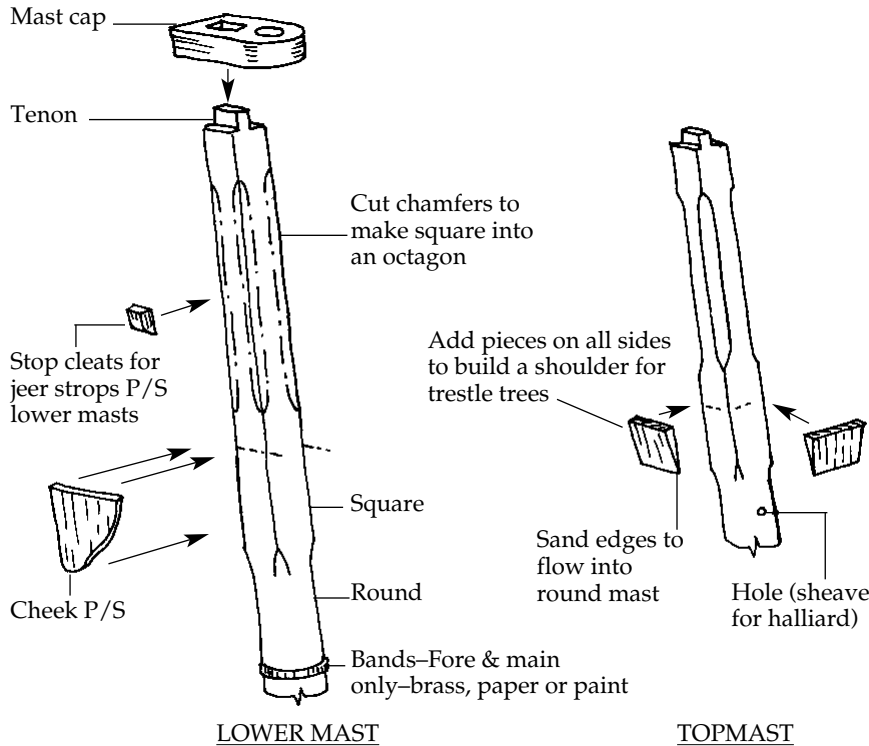
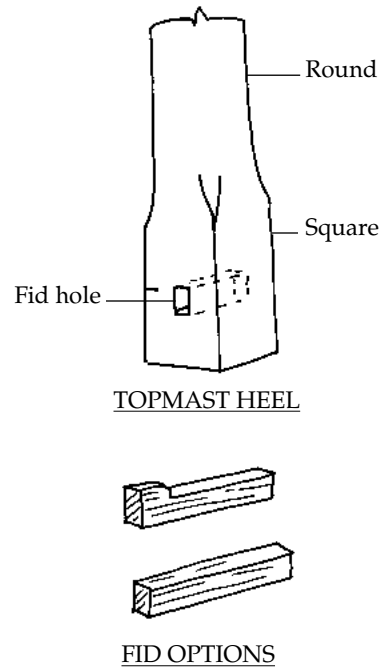

FIG. 46 - Fid Hole Positioning & Fid Options



The fore and main lower masts have bands around them. These masts on the real ship are made up in several pieces. The bands hold everything together. Make the bands from brass strips, or paper strips, or simply paint the bands on.

Mast Caps, Tops, Crosstrees, Boom Rest & Cleats: The mast caps are supplied laser-cut. You may need to file the holes a bit to fit the masts that you made. Add any eyebolts on the mast caps as required by the plans.

The fore and main crosstrees at the heads of the topmasts are next (see figure 47). Make these from strip wood supplied in the kit. When locating the chock pieces, make sure the formed opening between the chocks and crosstree will fit the mast head and heel snugly.

The basic platform for the fore, main, and mizzen tops are supplied laser-cut. On the real ship this piece would be double planking. The edge strip is also laser-cut. The ribs must be added using wood strips (see figure 48). These tops are simple and fun to make. And they will look a lot better, and are not as heavy as the metal castings supplied in the original kit for *Rattlesnake*.

The lower tops also have a netting guard rail as shown on the plans. For the net, you can obtain some fine mesh netting from a florist or craft shop.

FIG. 47 - Fore & Main Crosstrees

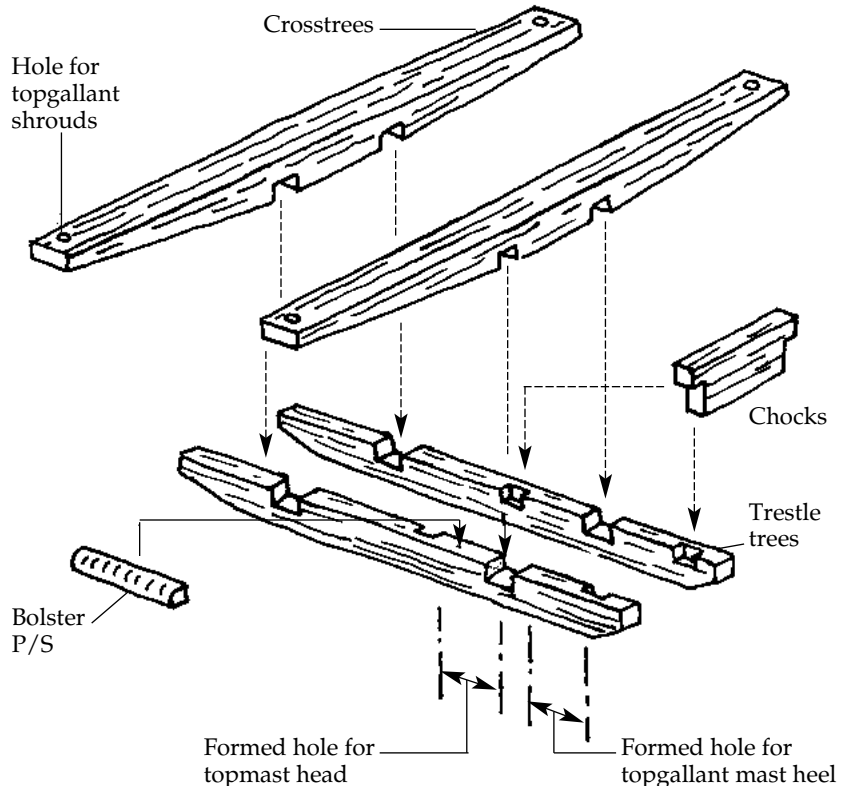

The boom rest for the mizzen mast is supplied laser-cut. To the laser-cut half ring, you will need to add the chocks separately (see figure 49).

Add the cleats around the masts as shown on the plans. The cleats must be made from strip wood. Drill a hole through the cleat and insert a pin for securing the cleat to the mast. Glue alone will not do the trick, because the cleat will probably fall off when you belay a line.

Mast Assembly: With all parts made and pre-fitted, assemble tops, caps, crosstrees and trestle tree assemblies on the lower masts, topmasts and topgallant masts. Glue in place. Check before you glue to make sure the lower mast, topmast, and topgallant mast is in line. Check both the side and fore and aft view. Adjust the topmast heel holes if necessary.

Mast Wedges & Mast Installation: A laser-cut piece that represents a ring of mast wedges covered by a mast coat (canvas) is supplied in the kit (see figure 50). Before installing the masts, slip this piece on the mast. Then, insert the mast in the deck hole and add some slivers of wood as necessary to jamb the mast in the hole. Check the alignment forward and aft, and athwartship, so the angles are in accordance with the plans. Finally, slide the mast wedge/coat piece down on the deck and add a touch of glue.

4. Building & Installing the Bowsprit & Jibboom

Taper the bowsprit and cut the tenon for the cap (see figure 51). The bowsprit cap is supplied laser-cut but you need to enlarge and angle the holes, and taper the top and bottom edge. The jibboom is a simple tapered spar with some shoulders at the end. Also, drill a hole at the end for the jib stay to pass through.

Assemble the cap and jibboom on the bowsprit. Be careful and align it correctly before you glue. The aft end of the jibboom sits on a saddle block as shown on the plans. Just aft of the block, the jibboom is lashed to the bowsprit. Wrap the lashing neatly around the two spars.

Insert the bowsprit assembly through the bow opening, into the notch in the center keel, and align it properly. Check the side angle, and make sure it lines up with the centerline.

FIG. 48 - Fore & Main Top Platform

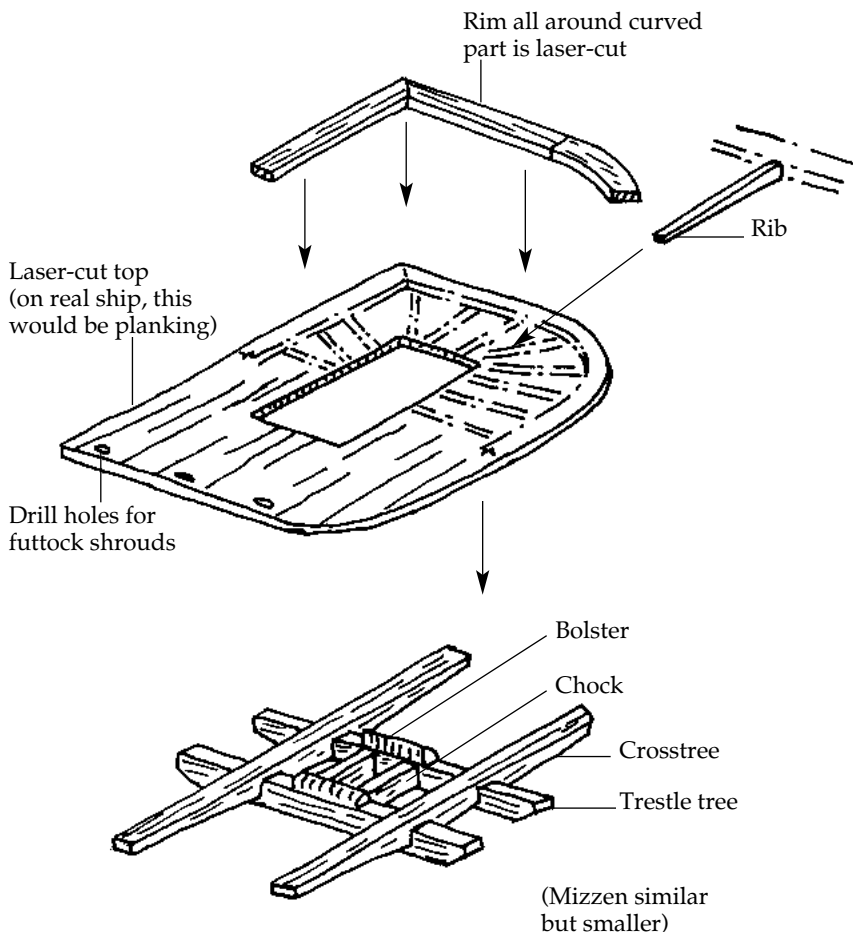

FIG. 49 - Mizzen Boom Rest

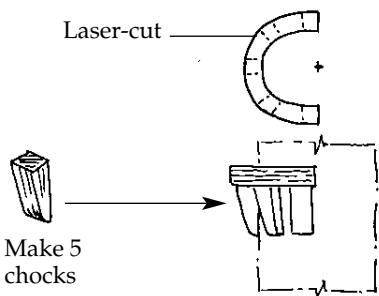

FIG. 50 - Mast Wedges/Coat

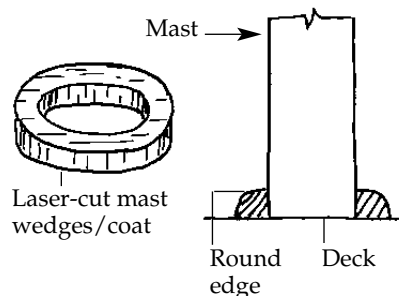

FIG. 51 - Bowsprit Tapering & Tenon

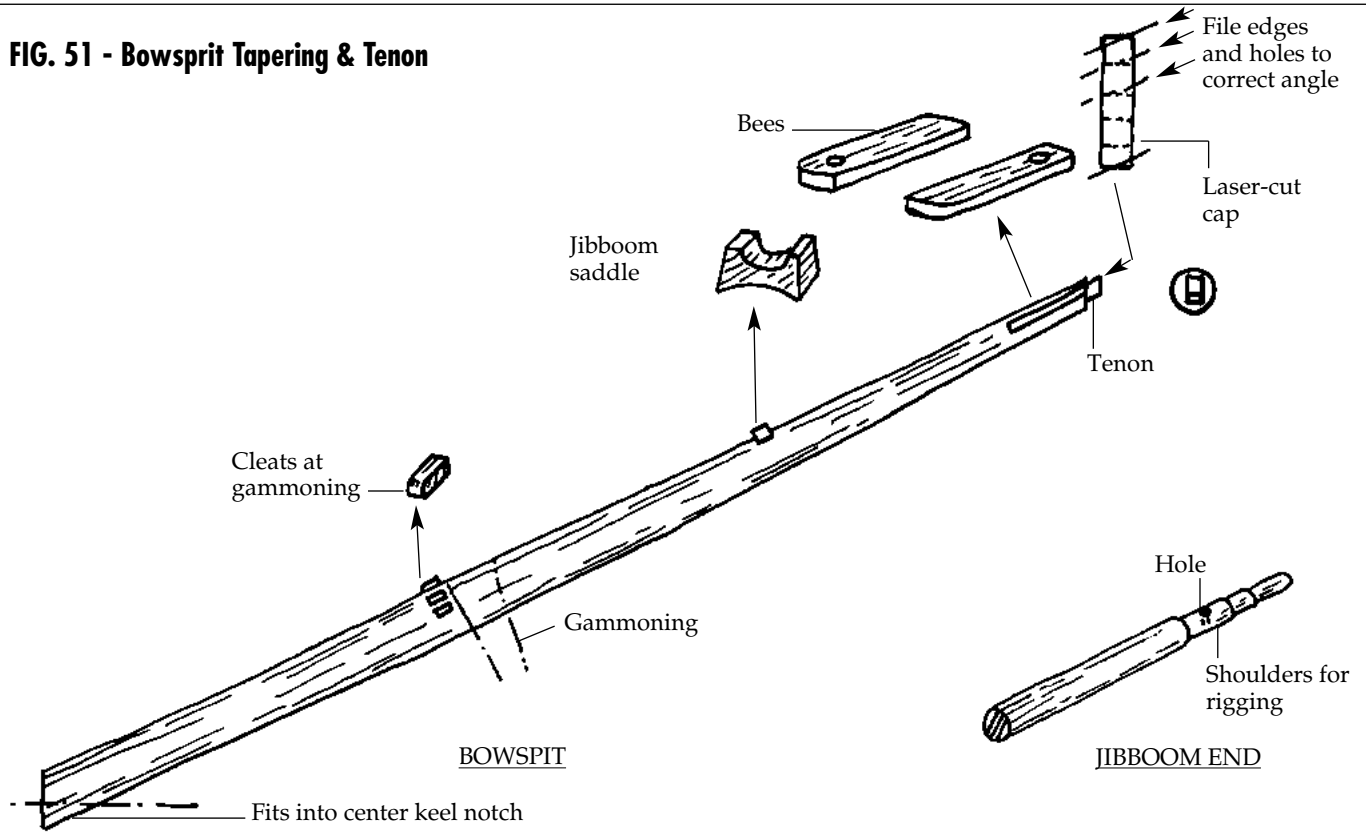

FIG. 52 - Yard Details

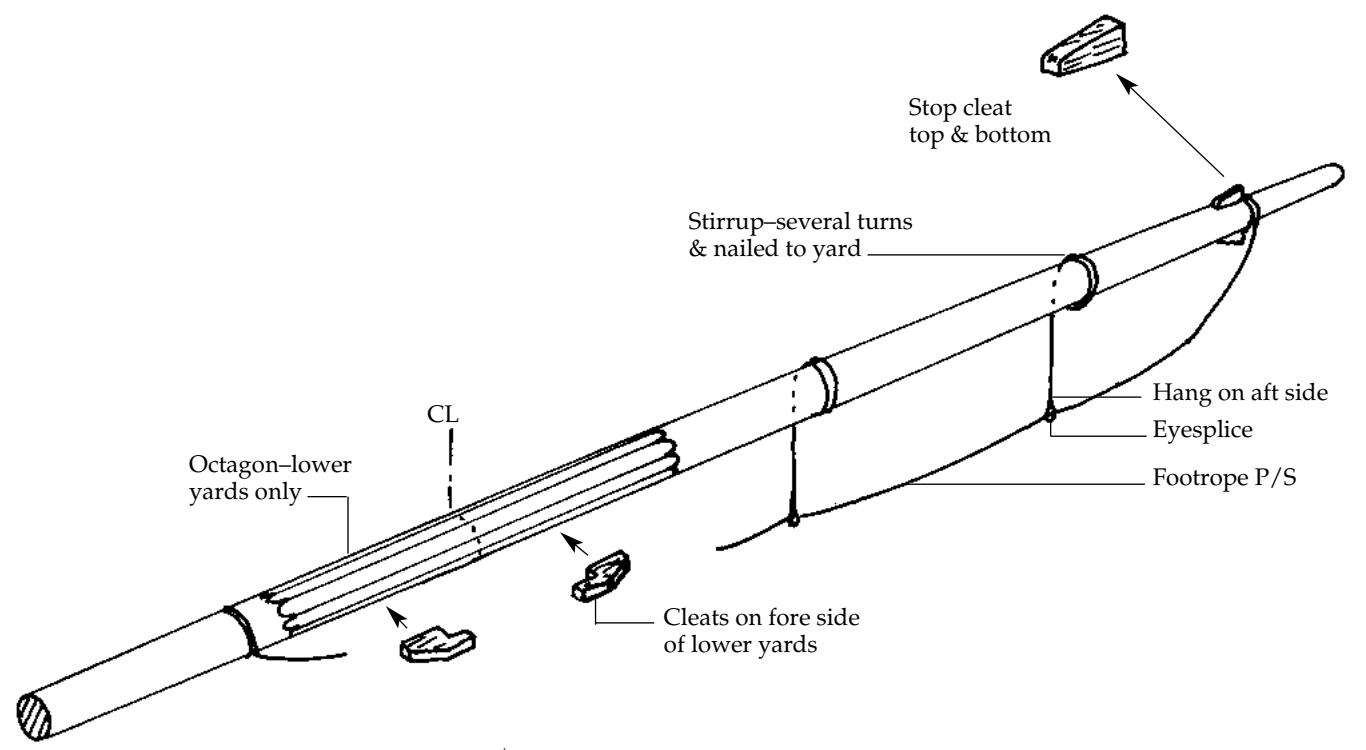
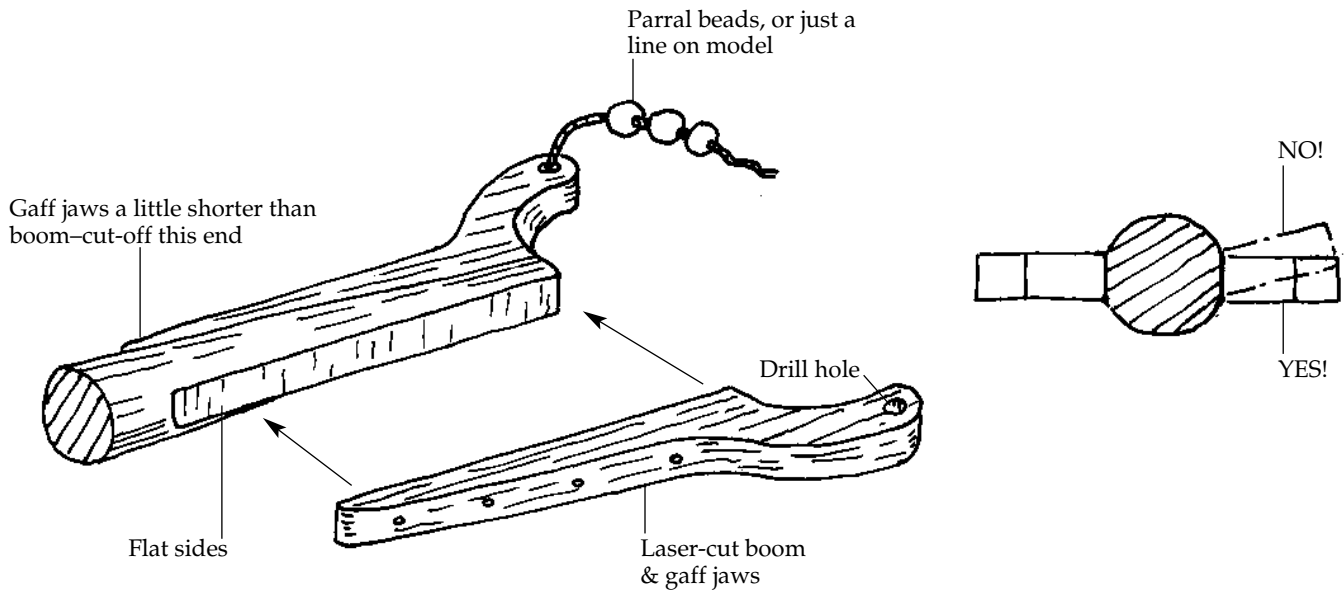

FIG. 53 - Boom & Gaff Jaws



5. Building the Lower, Crossjack, Topsail, Topgallant & Spritsail Yards

You will build the yards now, but the installation will be done along with the rigging. Some of the rigging is included with the yard construction because it's easier to do with yards in hand.

Footropes are best added at this stage. They are shown along with the spar details on the rigging plan (see figure 52).

There are a few cleats to be added to the shaped spar. The rigging plan and sketch shows the detail.

Reminder: Stain the yards before you set them aside. Sometime ago you were told to paint as you go, but a reminder here is in order. Once you start rigging, you must have all the staining and varnishing completed.

6. Building the Spanker Gaff & Boom

Like the yards, these spars should be completed in hand as much as possible and will be installed later. The new item now to build is a boom or gaff jaw. This is a fairly simple task, but make sure the port and starboard jaws line up and are level. Don't get them sticking up like bird wings. The jaws are supplied laser cut (see figure 53). The gaff jaws are somewhat shorter than the boom jaws. Simply cut the part to the correct length.

You cannot see it clearly on the plans, but the maximum diameter of the gaff and the boom is not at the center like the yards, but about 1/3 out from the forward end. Taper the gaff and boom the same as a yard, just start at a different place.

The parrals for the gaff and boom jaws are a series of wooden balls on a line. For the model, you can use some small beads or just use a line for the parral. Beads can be purchased separately.

STAGE G

GENERAL RIGGING & SAILMAKING INFORMATION

If you are new to the nautical world, there are a few rigging terms you should know. You old salts can skip this part and grab yourself a mug of grog.

Rigging Terms Defined

1. A sail has names for each edge and the corners. On a square sail, the top is the *head*, the bottom is the *foot*, and sides the *leech*. The lower corners are the *clews*. On a fore and aft sail, the top is the head, bottom the foot, aft side the leech, and forward side the *luff*. The lower forward corner is the *tack*, aft lower corner the *clew*, upper forward corner the *throat*, and the aft upper corner the *peak*. A triangular sail is similar except it has no head side, but the upper corner is called the head. There is no throat or peak.

2. *Standing rigging* refers to the fixed rigging that supports masts and spars. Generally, standing rigging is tarred; therefore, it is black or dark brown.

3. *Shrouds* are transverse support lines for masts. *Deadeyes* and their lines called *lanyards* are used to taught-up the shrouds, stays, and other lines. Deadeyes are made out of wood and have

three holes for reeving the lanyards. On a modern day ship, such a device would be replaced by a metal turnbuckle. Sometimes, you will find a *heart* or a *bullseye*. These are similar to a deadeye except there is only one large hole instead of three. They are used for more permanent installations. *Chain plates* are iron bars or rods for holding shroud deadeyes along the hull. At the topmast shrouds, there are no chain plates. Instead, there are rods or rope from the deadeye to the mast or lower shrouds. These are called *futtock* shrouds. If these shrouds go only to the lower shrouds, they generally tie into a wooden or metal rod called a *futtock stave*.

4. *Footropes* are lines that sailors stand on when working and furling sails. *Stirrups* hold the footropes.

5. *Stays* and *backstays* support the masts from fore and aft forces. A *running backstay* is one that has a tackle at deck. It can be moved along the deck if necessary.

6. *Bobstays* support the bowsprit from upward loads, and *guys* support jib-booms and bowsprits from side forces. Bowsprit guys are sometimes called *bowsprit shrouds*. Bowsprits sometimes have a vertical strut below the jibboom cap to help increase the downward pulling force of stays going back to the hull. This strut is called a *martingale* or *dolphin striker*. Head stays go through the jibboom, down to the dolphin striker, and back up to the bow. Separate stays starting at the jibboom, rather than continuing from the head stays, are called *martingale stays*. For *Rattlesnake* there is no dolphin striker.

7. *Running rigging* is a term applied to lines that move, reeve through blocks, and are used to operate sails and spars.

8. *Blocks* are wooden or metal shells with sheaves for handling lines. A *tackle*, or *purchase*, is a device made up of several blocks and a line to provide a mechanical advantage for handling sails and spars.

9. *Halliards* (also spelled halyard) are lines for raising and lowering a sail, yard, boom or gaff, or a flag. The part of a halliard attached to a yard is called a *tye*. For gaffs, the outer halliard is the *peak halliard* and at the gaff jaws is a *throat halliard*, named for the part of the sail it operates. *Downhauls*, *outhauls*, and *inhaul*s haul a sail along a boom, or up and down on a stay. *Sheets* hold the lower corners of a sail or boom. *Furling* means to bundle the sail up on its yard, boom, or mast, when not in use. *Clew lines* pull up the corners of a square sail, *leech lines* pull up the side, and *buntlines* pull up the belly of the sail for furling. *Brails* are like buntlines except they are used on loose footed fore and aft sails to

pull the sail in toward the mast for furling. *Bowlines* are lines attached to the sides of a square sail to pull the sail forward. These are used primarily on 18th century and older ships.

10. *Reef bands* are bands of reinforcement along the sail. These bands have short sections of rope called *reef points*. These are used to tie the sail to the yard or boom to shorten sail in heavy weather. *Reef tackle* is used to pull the sail reef bands up (or down) to the boom or yard.

11. *Parrals* (also spelled parrel) are lines or devices for holding yards, booms, and gaffs to their respective masts and spars. A *truss*, *jeer*, and *sling* are similar to a parral. These are terms describing lines used to hold a yard up and against the mast. These are most common for lower yards which generally do not move up and down.

12. *Braces* are lines attached to the ends of yards for directing the yard angles and holding them taught. *Lifts* are standing lines or running lines for holding yards when lowered. A *topping lift* refers to a line for holding up the end of a boom when the gaff is down or when there is no gaff. A *vang* is a line which steadies a gaff from swinging sideways and is fitted port and starboard.

This covers most of the important terms you should know for the *Rattlesnake* model. For the future, get yourself a good book on nautical terms.

1. Rigging Options

Just as in rigging the real ship, there are numerous options for rigging the model. Here is a list of some of the possibilities. In the end, it's your choice, but a few comments are offered for your consideration.

Model with sails: Rig the model complete with a full set of sails including all fore and aft sails, and square sails. Not many modelers go to this extreme. It is a good approach, if simply to have one model with all the detail. However, the mass of sail obscures a lot of the nice detail on the spars and on the deck. Sails really look better on a ship at sea, rather than on one sitting on a table. Also, a ship like *Rattlesnake* has spritsails hanging below the bowsprit. These look rather bulky on a model.

Model with furled sails: Furl all the sails. Yards are lowered on their lifts. This is a nice compromise. You get the feel of having sails, yet they are furled letting you see all the other detail.

Model with mixed furled & hoisted sails: For this option, use a mix of furled sails and full open sails, or sails with yards partially down. The square sails could be partially pulled up by buntlines and

clew lines. This gives the ship an appearance somewhat like it might be while in port; some sails furled, and some still partially up as if drying out after a day's run. There are a lot of possibilities here, so look for a pleasing effect. Take a look at artist paintings to get some ideas. Marine artist John Stobart's work is an ideal reference.

Model without sails: The model would have no sails and the yards would be lowered on their lifts. This is a proper look as if the ship is in port, and the sails have been removed for repairs. This is the method selected by most modelers and is intended for this model kit. Beginners should definitely select this option.

2. Using the Rigging Plan

The details of the masts and spars, and associated rigging, are shown on the rigging plan. Also, the spritsail yards and rigging are shown on the hull plan.

Rigging plans are often confusing because of the numerous lines involved, and the fact that overlapping and concealing of some of the detail occurs. For the *Rattlesnake*, the running rigging is in red to clarify the runs. Also, Mr. Campbell provided a descriptive note to aid in running the lines to their proper locations. If for some reason you get lost, consult the bibliography which lists the texts used to develop the rigging and should clear up any problems. These books are available as reprints.

3. Rigging Line & Block Sizes

Mr. Campbell's plans show block sizes in full ship sizes. He suggests using certain conversions for the model. However, his suggestion makes most of the blocks larger than scale. To be closer to the actual size, and smaller is always better than larger on a model, the following conversions are recommended. Furthermore, the kit-supplied sizes follow this table:

Full Size Block	Model Block
5", 6", & 7"	3/32"
8" & 9"	1/8"
10" & 11"	5/32"
13"	3/16"

Mr. Campbell's plans do not show the actual sizes of the various lines. The table on the right has been prepared to provide this information.

Note: The Foresail, Fore Topmast Stay-sail, Jib, spritsail, spritsail topsail, and spanker are not shown on Mr. Campbell's plan. Consequently, many of the running lines are not indicated. These are discussed further in the running rigging section of these instructions.

FIG. 54 - Seizings

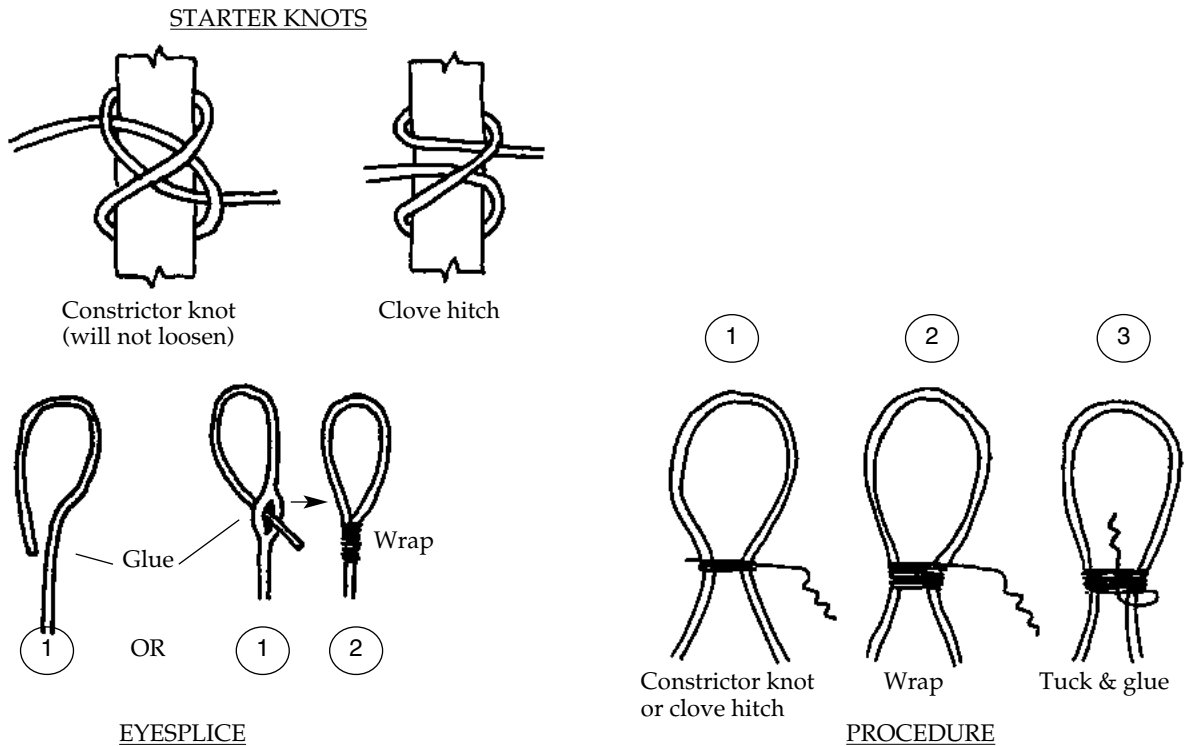

6. Rigging Tools

It is possible to make some homemade tools essential for the rigging process (see figure 56). You can also purchase similar shapes commercially.

7. Blocks & Deadeyes

When the plans indicate a bullseye or heart, you will need to use a deadeye and ream out the center to make a bullseye. Wooden bullseyes and hearts are currently unavailable. Also, where you see a sister block, simply glue two blocks together end to end.

The kit blocks and deadeyes should be sanded and the holes reamed larger, so it will be easy to reeve lines. An indispensable jig for holding small blocks is shown (see figure 57).

Stropping the blocks like the real ones is difficult at 3/16" scale. Some suggested modeling alternatives are shown (see figure 58).

8. Sailmaking

When making sails, it is important to choose the right type of material. Sail cloth for models must be light in weight, yet fairly opaque. A tight weave cotton cloth is acceptable. Cotton cloth is available from Model Expo. Linen is an ideal material, but most is too heavy for 3/16" scale models.

FIG. 55 - Rope Coils

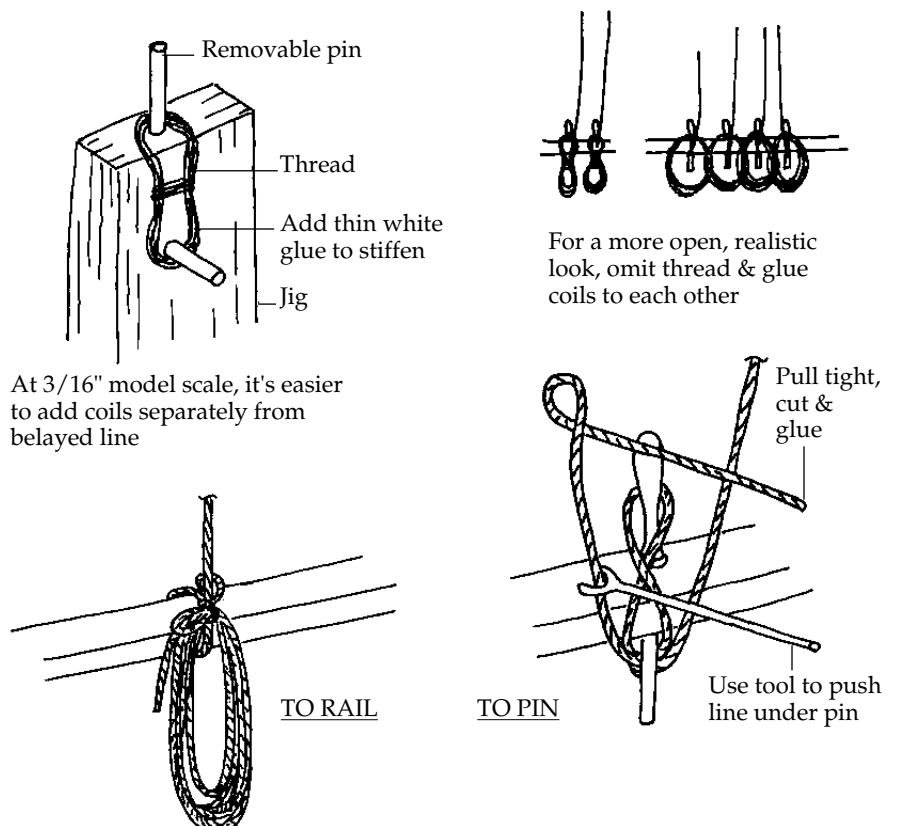

The cloth must be pre-shrunk, so wash it several times. When dry, iron the cloth, but be careful not to scorch it. Next, draw the seams and hem (tabling) lines and other reinforcements in light pencil, then sew the seams. A sewing machine makes fast work of the project. Use light tan cotton thread so that the seams show up nicely. Make some trial passes on a piece of scrap cloth and set the tension so the stitch does not make puckers in the stitch line. No actual reinforcement patches need be used. Instead, simply sew two stitch lines to represent reinforcements, such as the reef bands (see Figure 59).

After the stitching is completed, you may iron the sails. Be careful not to burn them. Next, cut the sail shape using line "A" as shown in the sketch. Then roll the hem according to the sketch, iron it flat and sew (as close to line "B" as possible). Tuck the ends and hand sew the corners as shown. The sail is now ready for stretching.

Stretching the Sails: This step will assure that the sail shape is correct, since it may have been altered during sewing. Using the original pattern, draw the outline of the sail's shape on a piece of paper. Place the piece of paper down on a solid but penetrable backing, such as a wooden board or cork. Now wash the entire sail again and lay it over the outline you've just drawn. Stretching the wet sail to the outline's shape, stick pins through its outer edges and into the backing to hold it in place. When the sail is dry, it will have the proper shape. Iron it flat.

Edge Boltropes & Reef Points: Sewing edge boltropes onto the sail can be omitted since they appear so small in 3/16" scale. However, if you wish to include them you may follow the tedious method shown (see figure 60). The sketch also shows how to install reef points.

Furled Sails: It is impossible to furl a sail made from the same material and of the same size used for the fully set sail. The cloth is usually too heavy, causing the sail to become too bulky looking. There are two solutions to this problem. First, you may use a lighter material such as Silkspan, which is a model airplane covering tissue; or second, you may elect to use the same cloth, but cut it to a proportion one-third the size of the original to reduce bulk (see figure 61). You may even need to do this with silkspan, depending on the size of the sail. Make a test first to see how much material is required for a nice tight furl.

Even if you furl the sails, you must still add some seams and hems. The detailing will show somewhat on the furled sail.

FIG. 56 - Homemade Rigging Tools

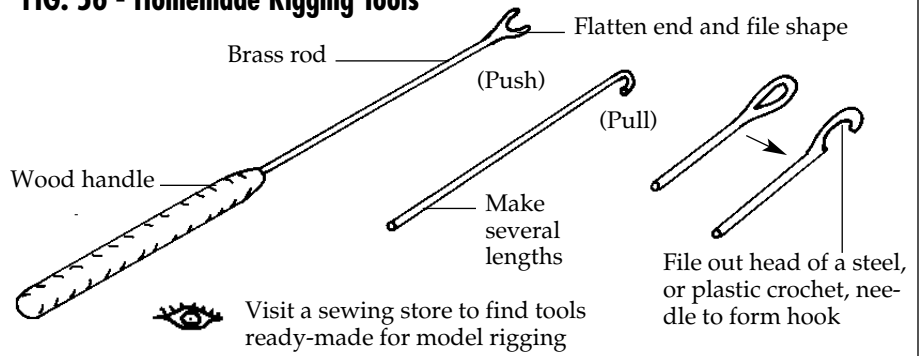

FIG. 57 - Block-holding Jig

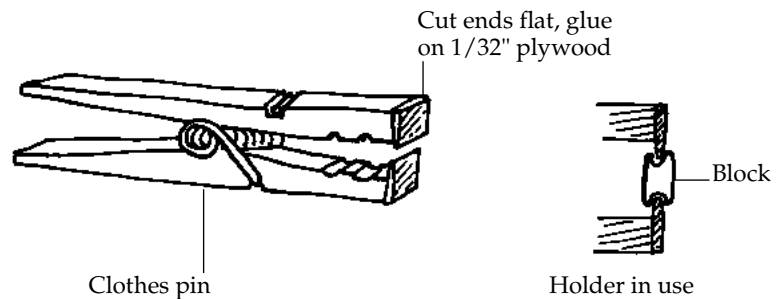

FIG. 58 - Stopping The Blocks

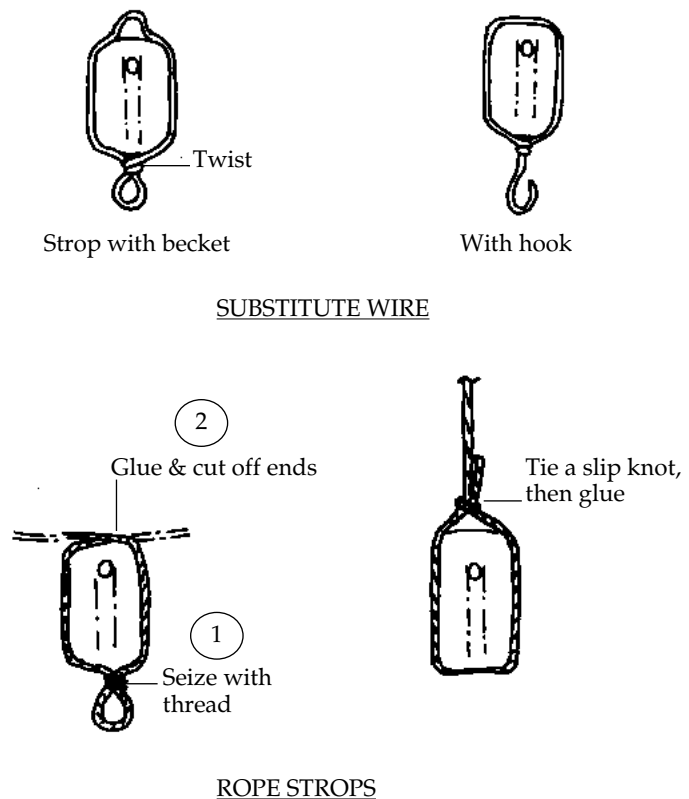
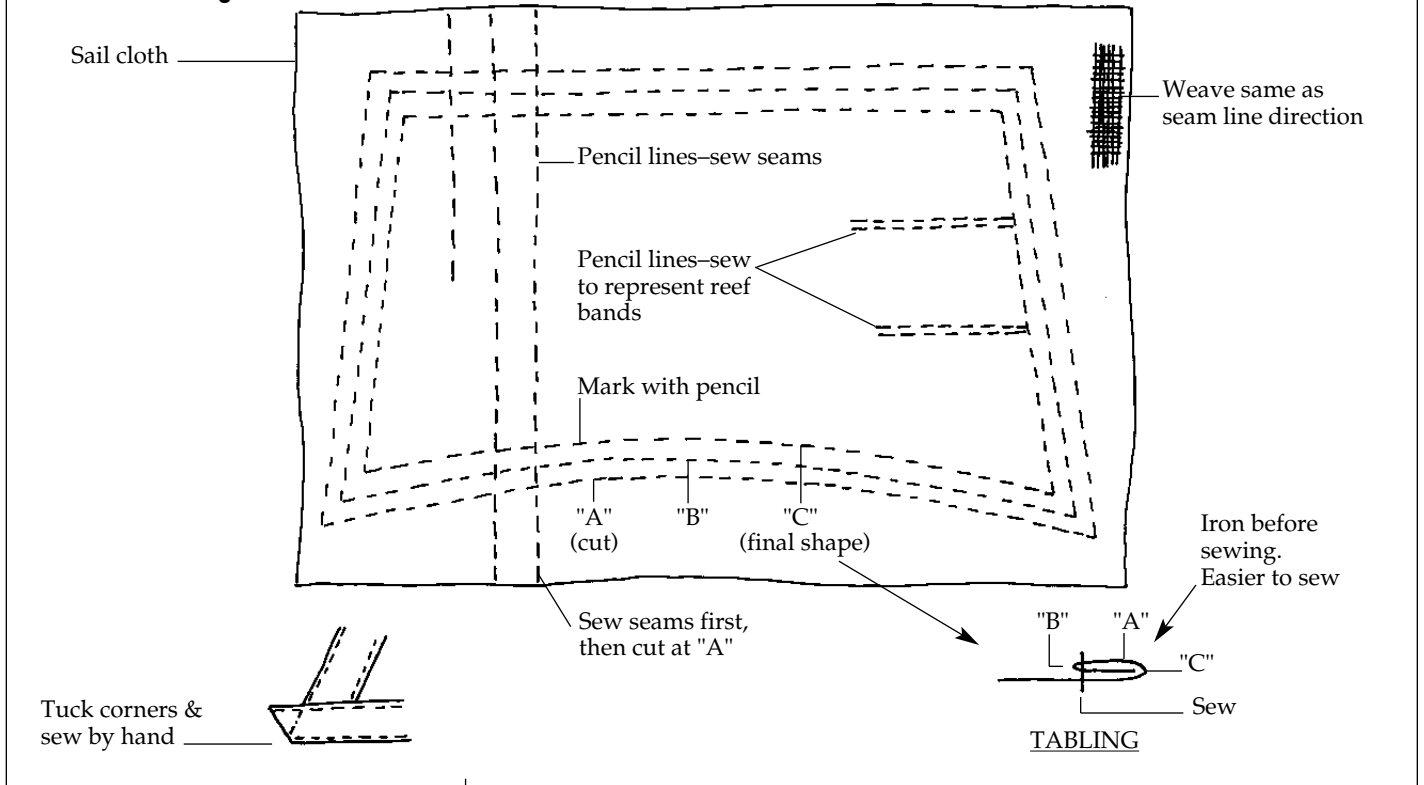

FIG. 59 - Making The Sails



9. Rigging the Model Without Sails

Even though you may have chosen not to include sails, you ought to include most all of the lines attached to the sails, such as clew lines and sheets, buntlines and leech lines, reef lines, and fore and aft sail halliards and downhauls. These lines are not removed when sails are removed, but simply shackled together or tied off or secured to some other stowage point. The sketches herein and on the plans show some of details.

When rigging a model without sails, most modelers do not install bunt and leech lines, or reef tackle and their blocks, and most all of the sheets for fore and aft sails are omitted. The choice is yours. But, the more lines you install, the more fun it will be, and in the end, the more realistic. Try to visualize what lines are best removed with the sail and which ones are easily left in place after being unhooked or untied from the sail.

FIG. 60 - Edge Boltropes & Reef Points

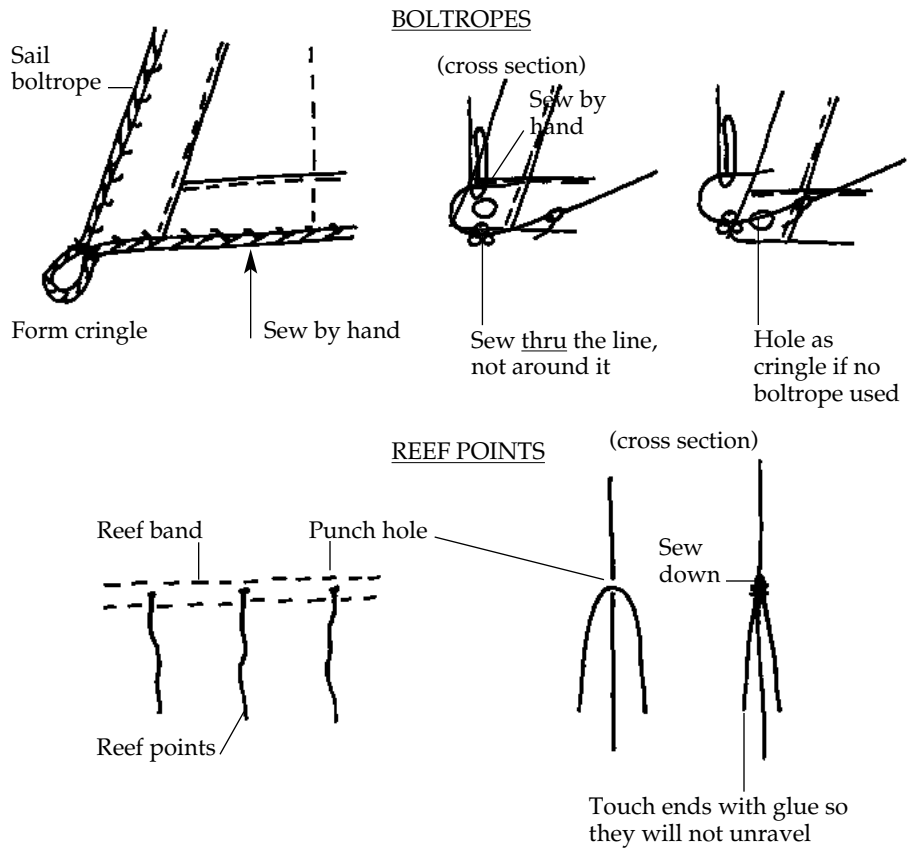

STAGE H

STANDING RIGGING

Keep your lines handy, sorted by sizes, and have them all nicely beeswaxed before you start. For seizings, you can use cotton, silk, or nylon sewing thread. This should also be beeswaxed. Keep your white glue and super glue handy for dabbing to seizing if necessary, to hold them in place.

1. Shrouds

Begin the standing rigging with the lower shrouds. The lower deadeyes have steel rod chain plates. These are made of brass wire provided in the kit (see figure 62). If you can't work with all this fine wire, substitute a simple wire strop as shown in the sketch.

The rigging plan shows the proper sequence for installing the shrouds. To set up the shrouds, make a temporary jig of brass wire to space the deadeyes as you do the seizing (see figure 63). Make the wire jig slightly longer than the final spacing of deadeyes. When you reeve the lanyards, they will stretch and tighten the shrouds to the proper final spacing. You may need to make a test shroud first to see how much it stretches. This figure also shows the sequence for reeving the lanyards. When looking outboard at any deadeye, you should always start with a knot at the upper left hand deadeye hole. Consequently, port side deadeyes have the knot aft and forward on the starboard side. Keep an eye on the masts as you rig shrouds, so you will not pull them out of line.

Instead of chain plates, the topmasts have futtock shrouds (see figure 64). Notice that the topgallant shrouds have no deadeyes at all. The shrouds go through the crosstrees, around a futtock stave, and all the way down to the lower top. There, they are seized into some thimbles attached to the lower deadeyes.

After the shrouds are in place, add the ratlines (see figure 65 for several optional methods). Make sure you beeswax the ratlines well before they are installed. The wax will help hold the ratlines into a slight downward curve. If the ratlines tend to bow upward, tug them gently into position. You may need to add a little super glue on the line to "freeze" them. Ratlines are difficult to do if you tie the clove hitches. Try to hold a group of shrouds between your fingers so that as you tie the knots, you will not alter the spacing between shrouds.

FIG. 61 - Furled Sails

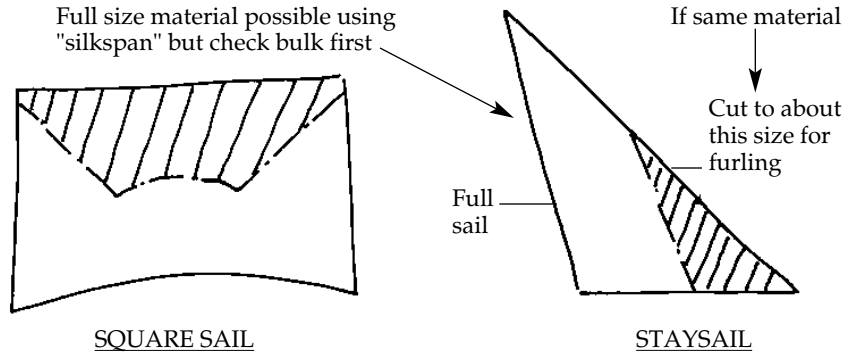

FIG. 62 - Chain Plates

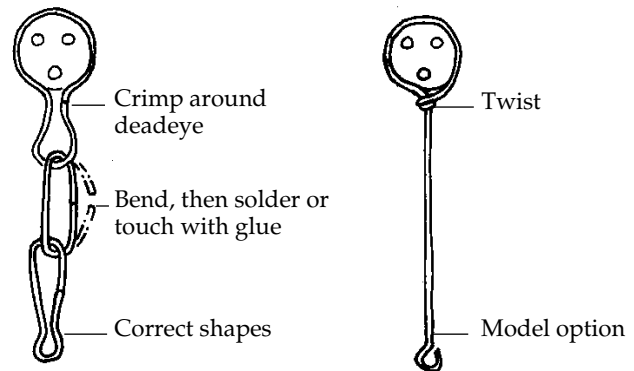

FIG. 63 - Spacing The Deadeyes With A Wire Jig

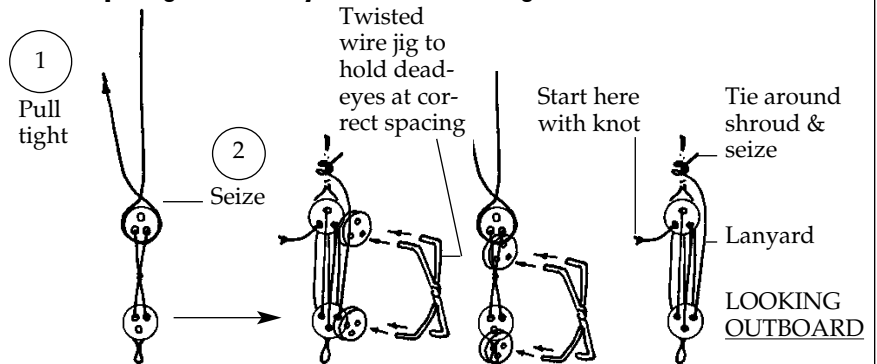
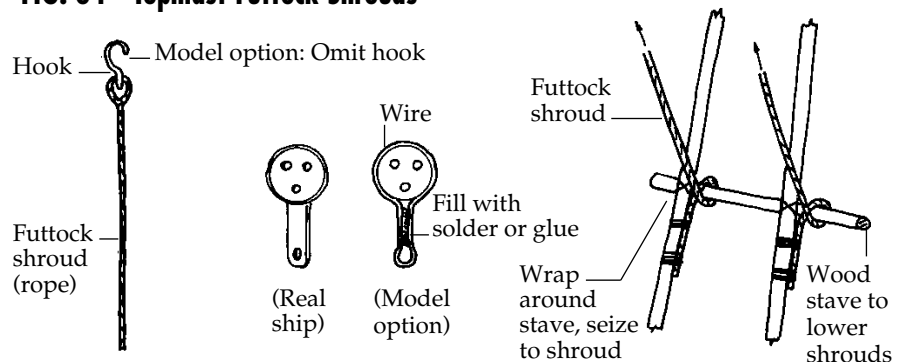

FIG. 64 - Topmast Futtock Shrouds



2. Backstays

The topmast and topgallant backstays are similar to shrouds except there are no ratlines connected to them, except at the very top. Install them after the shrouds are installed.

3. Fore & Aft Stays

Install the fore and aft stays after the shrouds and backstays are completed. Be careful not to pull the masts out of line when installing the stays.

4. Detail at the Tops

There are quite a few lines terminating at these points and it can get quite confusing (see figures 66 and 67 for detail at the mastheads). Notice the stay with the long eye and mouse. The mouse is just a weaved tapered ball of lines. On the model, it can be made by wrapping a thread in a bundle around the stay or it may be omitted altogether. Simply seize the stay together.

The sketch also shows the sister block in the shrouds. As noted earlier, just glue two blocks together.

5. Bowsprit Rigging

The standing rigging at the bowsprit is shown (see figure 68). The most unique items are the heart and open heart for the forestay. Both are supplied laser cut but you will need to shape them up a bit, and file a groove around the edge. The bowsprit shrouds also have hearts, but these are smaller and can be made from drilling out the center of a dead-eye.

The bobstay is a double line. Mr. Campbell's plan shows the line seized together at the heart and just ahead of the stem. The lower seizing at the stem could be omitted. Lever's text (see bibliography) does not show a seizing here.

6. Footropes

As noted earlier, footropes for yards, spanker boom, and jibboom are more easily installed while the spars are still in hand. Like the ratlines, you may need to work on the footropes a bit to get them to hang naturally.

This completes the standing rigging. Take another look before you move on. Check to make sure you did not pull a mast, or the bowsprit and jibboom out of alignment. Now is the time to correct all your mistakes.

FIG. 65 - Ratlines

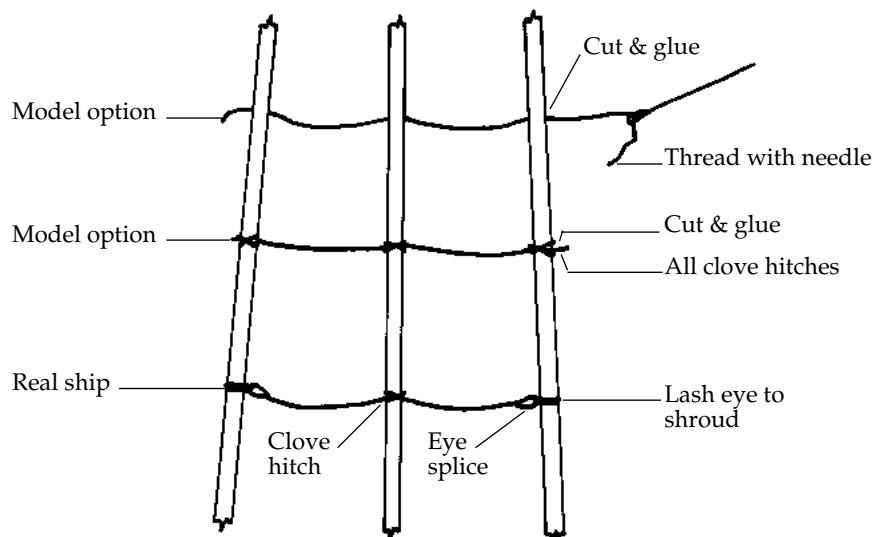

FIG. 66 - Detail At The Main Topmast Head

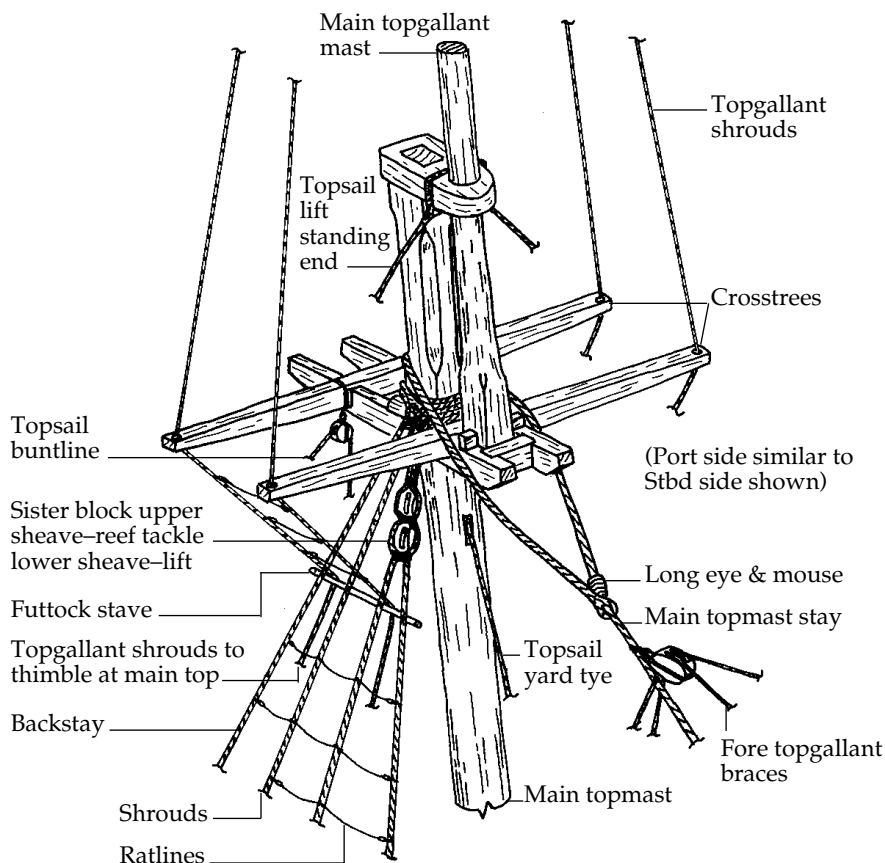

FIG. 67 - Detail At The Main Mast Top

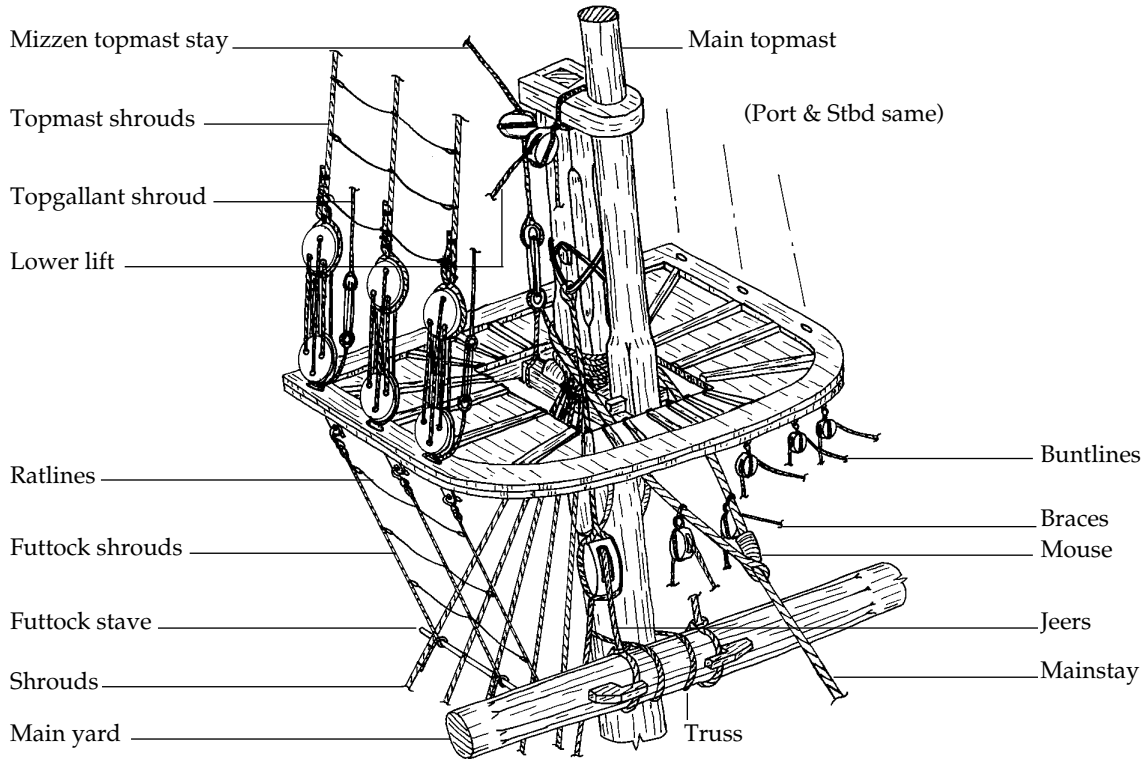
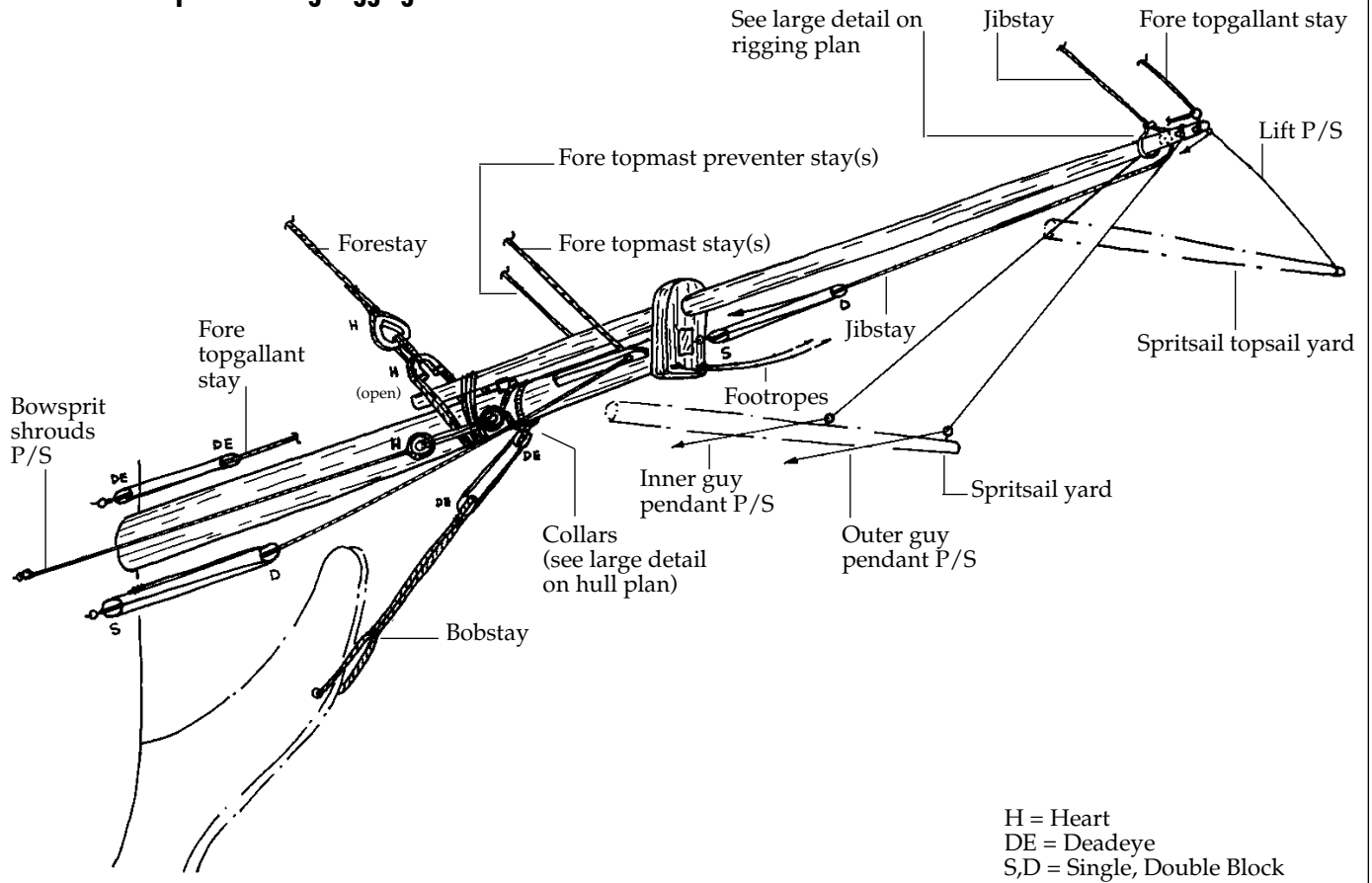

FIG. 68 - Bowsprit Standing Rigging



H = Heart
 DE = Deadeye
 S,D = Single, Double Block

FIG. 69 -Rattlesnake Sail Plan

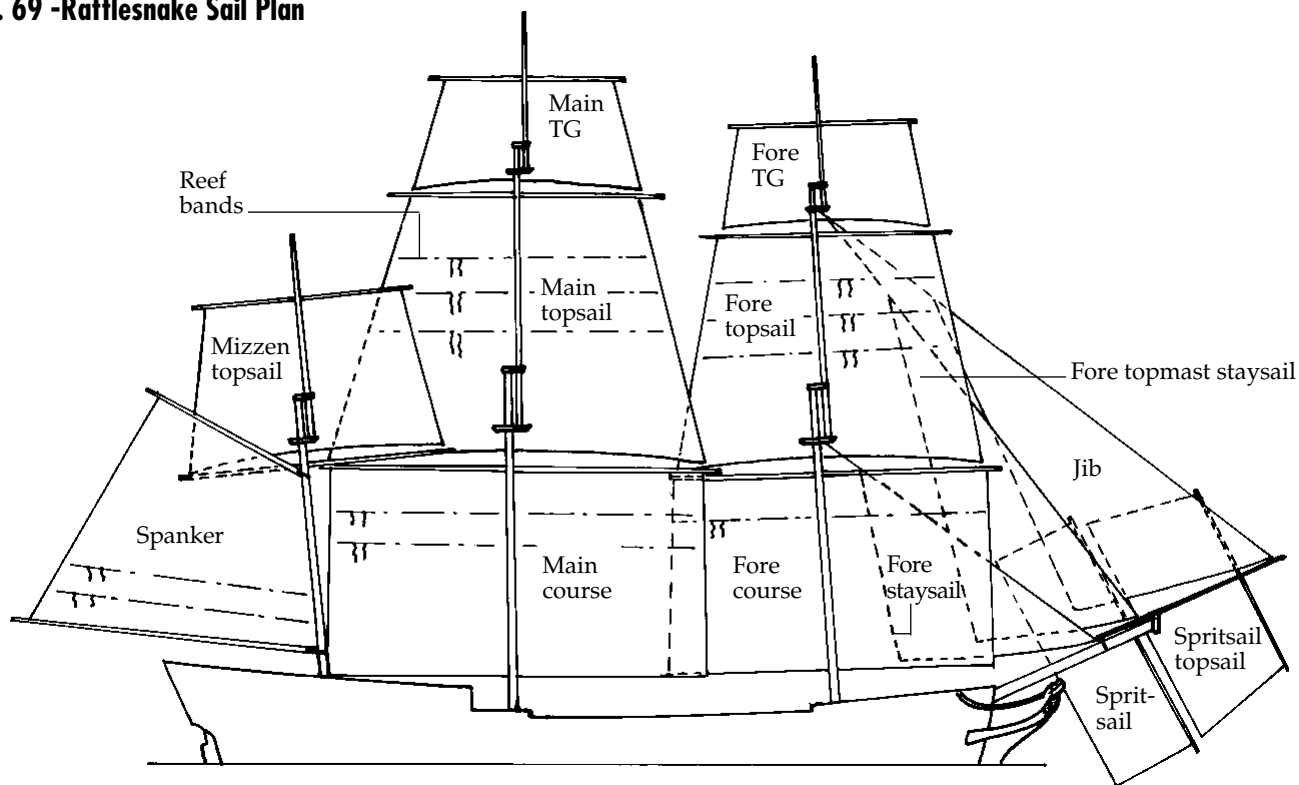

FIG. 70 -Typical Head Sail Rig

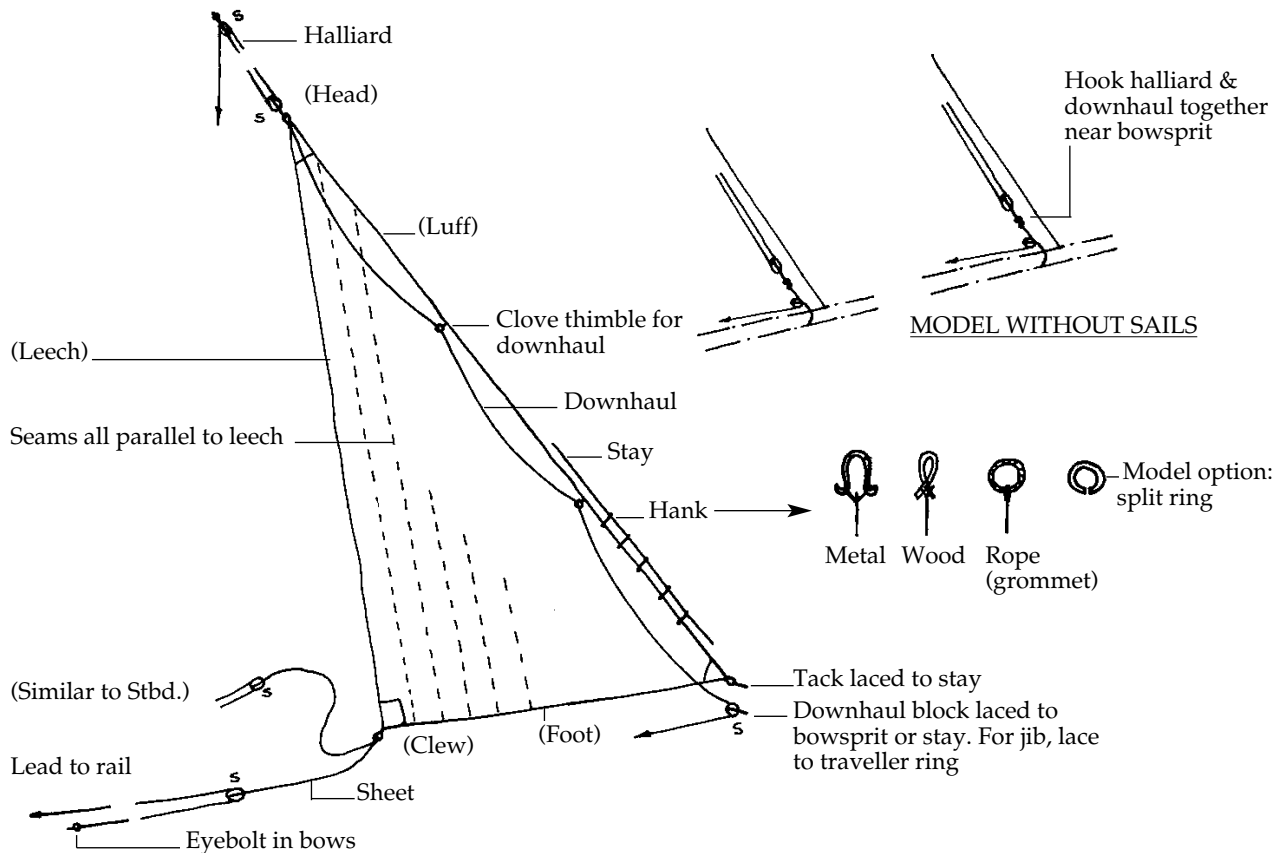
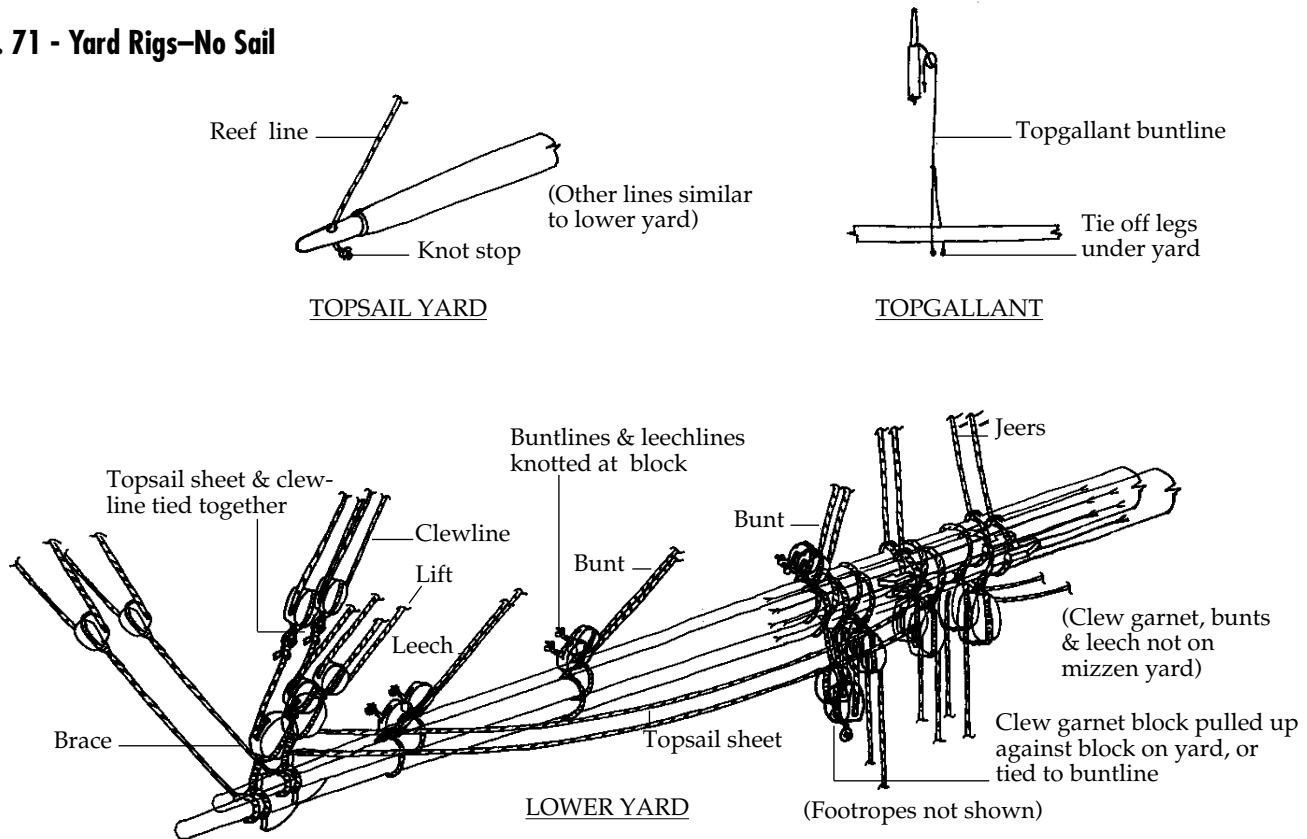

FIG. 71 - Yard Rigs—No Sail



STAGE I

RUNNING RIGGING

It is now decision time. Will you rig with sails, or rig without? The following paragraphs discuss both choices and how to go about them. Each particular sail, along with its spars, is presented separately so you can finish one sail grouping entirely before moving to the next. The sequence is not that critical, but it is recommended that you start at the bow, do all the fore and aft sails first, then add the square sails.

Mr. Campbell's plans do not show all the sails that were apparently carried by the ship. Figure 69 is a small sail plan in case you wish to install sails. This sketch is based on the sail plan developed by Howard I. Chapelle.

1. Fore Staysail, Fore Topmast Staysail & Jib

Note: These particular sails and their lines were omitted on Mr. Campbell's plans. However, they should be considered when rigging the model even if no sails are used.

For simplicity, these sails can be called head sails (see figure 70 for a typical sail). If you rig the model with the sails, add the halliards, downhauls, and sheets to

the sails before installing them on the model. Leave enough extra line so that after you reeve the lines through the various blocks you have enough left for belaying.

This ship is late enough in time that it probably had metal hanks for bending the head sails to the stays. Earlier, they would have used wooden hanks, and before that small rope grommets. In any case, for the model, you may use a simple brass ring.

If sails are not used, attach the halliard to the downhaul and bring it down to the end of the bowsprit as shown in the sketch. The halliard runs are identical to a rig with sails except for the location of the head block. The sheets are removed with the sails.

2. Fore and Main Course, & Mizzen Crossjack Yard

The fore course is detailed on the plans. The Main course is identical except for the overall size of the sail itself. There is no mizzen course. The rigging plan shows a nice detail of the fore, main, and mizzen crossjack yard truss and jeers at the center of the yards. They are all the same. The truss is used to hold the yard tightly against the mast. The jeers are used to support the weight of the yard. There is no halliard because the yard is stationary. The jeers are rigged, however, so the yard can be lowered (on the real ship) to the deck for re-

pairs if needed. If the course sails are not used, you can omit the sheets and bowlines entirely. The buntlines and leech lines could be knotted off at their lead blocks, as shown on the plans, or left off (see figure 71 for some ideas).

3. Fore, Main & Mizzen Topsails

The fore, main, and mizzen topsails are all similar except for the size of the sails. The plans show details for the fore topsail.

The bowlines, and other lines obviously go to a different belaying point. The plans show most of the lines except the bowlines for the main and mizzen sails. The main bowlines should go to a block at the tops and lower part of the fore mast, then down to the deck for belaying. The Mizzen bowlines go to the main mast at similar points. For a better description of the sail lines, consult the Darcey Lever text listed in the bibliography.

When omitting topsails, the yard should be lowered on its lift as shown on the plans for the main and mizzen topsail. Treat the buntlines like you did for the courses. The clew line blocks and sheets are hooked together just above the lower yardarms.

Rather than a truss, the topsail yards have a halliard tye and a rib and truck parral. This is detailed on the plans. The topsail has no leech line like the courses, but it does have a reef line.

FIG.72 -Typical Spanker Sail

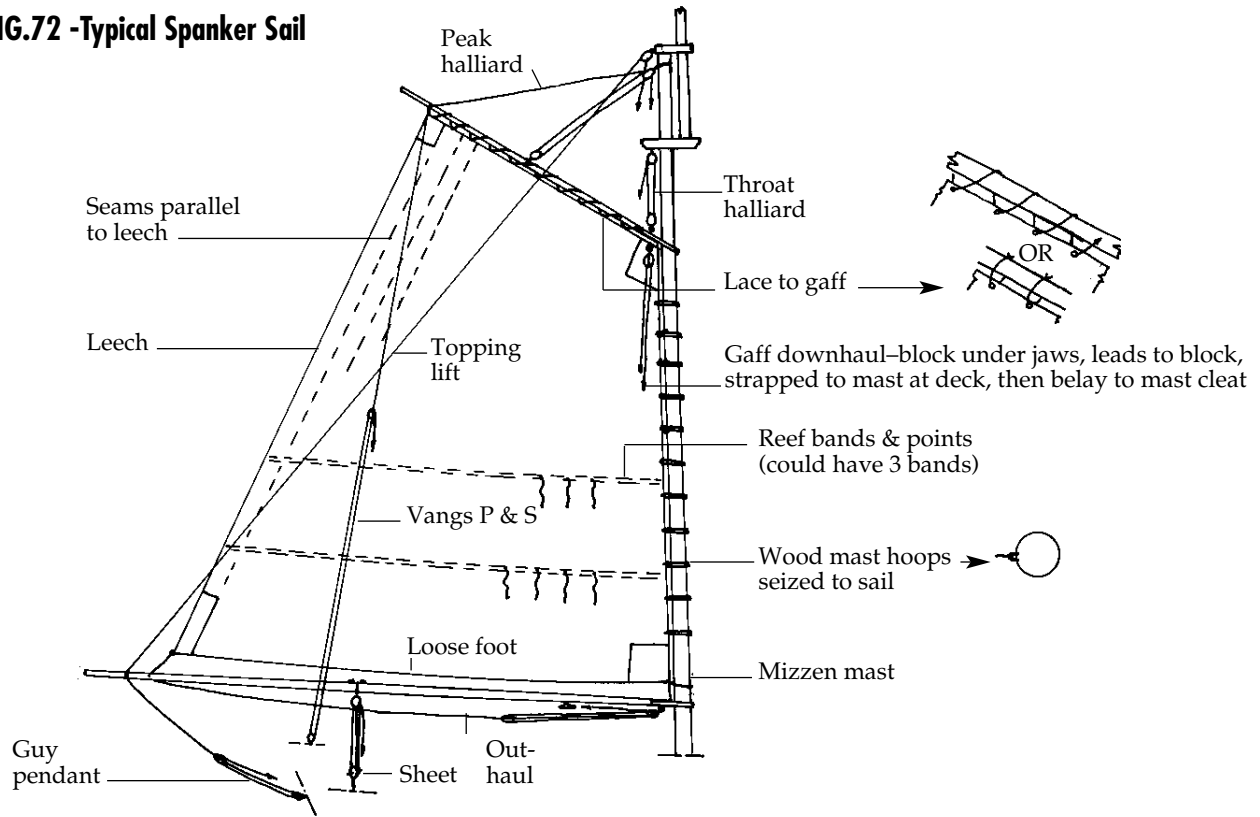
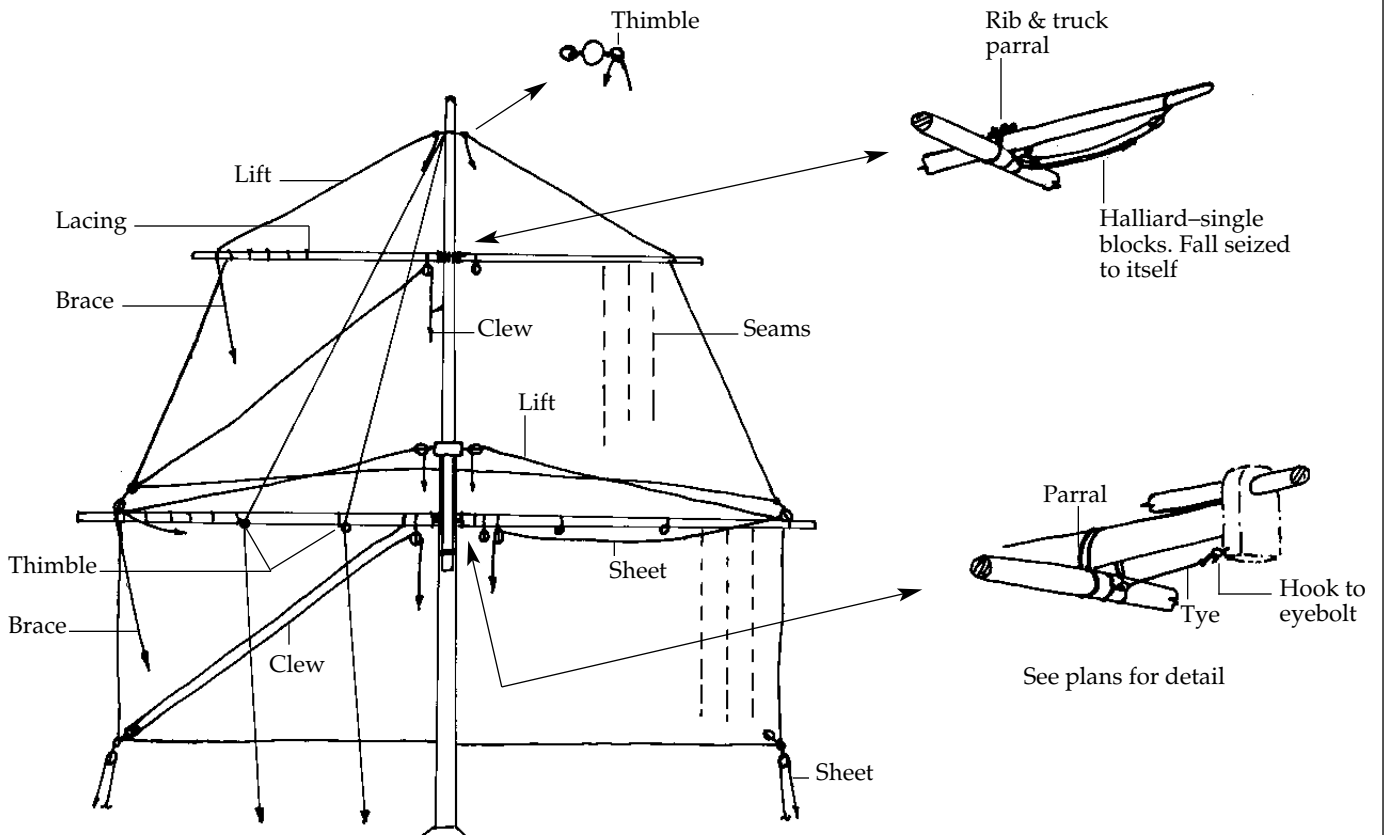

FIG. 73 -Spritsail & Spritsail Topsail (Looking Down)



Oddly, the course does not have a reef line. The reason; courses are hauled up by leech lines and topsails by reef lines (see figure 71—it shows the reef line knotted off for a model without sails).

4. Fore & Main Topgallant Sails

The parrals and halliard ties are similar to those of the topsails, but notice that the topgallants have a different type of buntline than the topsails. It is a single line with a split near the bottom of the sail. With no sails the buntline could be tied around the yard as shown (see figure 71).

There is a single-line clew line, no leech line, and no reef points and tackle. The lift is also single.

5. Spanker

The spanker is another sail not shown on the Campbell plan (see figure 72 for a typical sketch of this sail).

If no spanker is used, the rig should look like the rigging plans show, except that you should add the gaff downhaul not shown on the Campbell plan. Also, the mast hoops could be added and piled up on the boom jaws. You could also lower the gaff since it is not fixed, but it looks better in the up position with the vang in place. A spanker can also be called a driver. The two terms seem to get mixed up between naval and merchant service, and depends whether the sail has a boom or not.

6. Spritsail & Spritsail Topsail

These sails do not appear on the Campbell plans either but at least the braces, lifts, and halliards do (see figure 73). Viewed from above, these sails look like a lower course and topsail on a mast, because they are operated in the same manner.

With no sails, the spritsail sheets should come off with the sails and all other lines handled similar to a course and topsail rig without sails.

7. Miscellaneous Rigging

Flags and Flag Halliards: Flag halliards are located at the fore and main topgallant mast pole, the mizzen topmast pole, and at the outer end of the spanker gaff. The halliards are single lines reeved through very small blocks on the gaff, and sheaves in the trucks of the fore, main, and mizzen poles.

If you fly the flags shown on the plans, you can make them from light weight cotton cloth and paint the colors on with acrylics. Acrylic paint is fairly flexible. Paper can also be used. Shape the paper before installing it so that the flag hangs naturally.

FINAL TOUCHES

After all the rigging is in place, re-check every line, and make sure all the seizings are sound. If necessary, add another touch of super glue to seizings. Check to see if there are any shiny places on the rig. If necessary, touch up the standing rigging with black paint, or black liquid shoe polish. For running rigging, use a tan stain, or brown liquid shoe polish. Check to see if you have fouled any of the painted wooden parts during the rigging process and make repairs as necessary.



CONGRATULATIONS!

You've done it! Your model is completed and we hope you like the results. If this was your first effort, and you're less than happy, remember that it is only through repeated experience that your level of skill will develop. Subsequent models can only get better. Don't hesitate to call Model Expo when you're ready to begin your next ship modeling project.

SCALE CONVERSION TABLE

R I G G I N G

Diameters for Lifesize Vessel	Diameters in Tenths of an Inch	Diameters Converted to 3/16" Scale
		Inches in 10ths ÷ 64=
5/16"	.3125"	.005" (.12mm)
3/8"	.375"	.006" (.15mm)
1/2"	.5"	.008" (.20mm)
5/8"	.625"	.009" (.25mm)
3/4"	.75"	.012" (.30mm)
7/8"	.875"	.014" (.35mm)
1"	1"	.016" (.40mm)
1-1/4"	1.25"	.020" (.50mm)

B L O C K S

Lengths for Lifesize Vessel	Lengths Converted to 3/16" Scale
	Inches in 10ths ÷ 64=
4"	.06" (1.52mm or 1/16")
5"	.08" (2.03mm or 5/64")
6"	.09" (2.28mm or 3/32")
7"	.10" (2.54mm or 7/64")
8"	.13" (3.18mm or 1/8")
10"	.16" (4.06mm or 5/32")
12"	.19" (4.83mm or 3/16")

FORMULAS FOR CONVERTING MILLIMETERS AND INCHES

1 mm = .03937 of an inch

To find tenths of an inch:

.03937" x mms = tenths of an inch

To find mm's from tenths of an inch:

Tenths of an inch ÷ .03937" = mms

RIGGING LINE DIAMETERS

.10mm (.004")

.20mm (.008")

.25mm (.010")

.40mm (.016")

.50mm (.020")

.60mm (.024")

.75mm (.030")

.80mm (.032")

.90mm (.035")

.95mm (.037")

1.00mm (.039")

1.20mm (.047")

1.25mm (.049")

1.30mm (.051")

1.50mm (.059")

1.60mm (.063")

1.70mm (.067")

1.75mm (.069")

2.00mm (.079")

2.50mm (.098")



BIBLIOGRAPHY

1. *The History of American Sailing Ships*, by Howard I. Chapelle. 1935 (Reprinted)
Provides a complete description of Privateer ships, the hull lines, sail and other plans of *Rattlesnake* prepared by Mr. Chapelle from Admiralty draughts.
2. *The Search for Speed Under Sail 1700-1855*, by Howard I. Chapelle. 1967 (Reprinted). Additional information and drawings of *Rattlesnake*
3. *The Young Sea Officers Sheet Anchor*, by Darcey Lever. 1819 (Reprinted)
Contemporary rigging text and is a basis for the Model Shipways rigging plan reconstruction for *Rattlesnake*. Excellent drawings of the entire rig and sails.
You should have this book if you intend to add sails to the ship.
4. *Steel's Elements of Mastmaking and Rigging*, by David Steel. 1794 (Reprinted)
In addition to basic rigging discussions, this text contains sizes of rigging and blocks for various ships of the period. Tables for ships of 14 to 18 guns, 250 to 300 tons is adequate for *Rattlesnake*.
5. *The Neophyte Shipmodeler's Jackstay*, by George F. Campbell. 1962, Model Shipways. An excellent modeler's guide for period ships.

Note: Most books are available through Model Expo, Inc.
Please check current catalog for availability.

Other Fine Kits from Model Shipways



MODEL SHIPWAYS
• QUALITY KITS SINCE 1946 •



SULTANA
Model Shipways Kit No. MS2016



WILLIE L. BENNETT
Model Shipways Kit No. MS2032



BLUENOSE
Model Shipways Kit No. MS2130



RATTLESNAKE
Model Shipways Kit No. MS2028



CHARLES MORGAN
Model Shipways Kit No. MS2140



BENJAMIN LATHAM
Model Shipways Kit No. MS2109

OUR GUARANTEE

If less than delighted, return your purchase within 30 days in original condition.

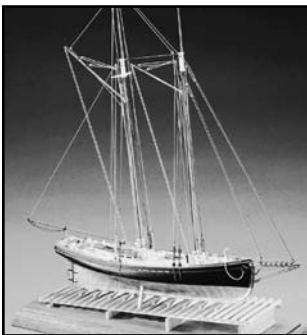

PHANTOM
Model Shipways Kit No. MS2027



EMMA C. BERRY
Model Shipways Kit No. MS2150

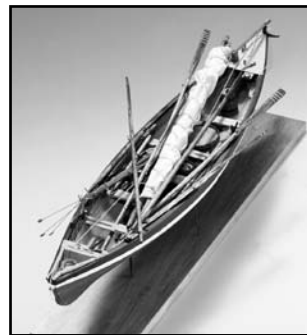

BEDFORD WHALEBOAT
Model Shipways Kit No. MS2645



USS CONSTITUTION
Model Shipways Kit No. MS2040



NIAGARA
Model Shipways Kit No. MS2240



FLYING FISH
Model Shipways Kit No. MS2018



PRINCE DE NEUFCHATEL
Model Shipways Kit No. MS2110



PRIDE OF BALTIMORE II
Model Shipways Kit No. MS2120

MODEL SHIPWAYS

Sold & Distributed by Model Expo, a division of Model Shipways, Inc.
3850 N. 29th Terrace, Hollywood, FL 33020

Toll-Free 800-222-3876 Monday - Friday 9-6 ET • Fax 800-742-7171

SAVE TIME & MONEY... ORDER DIRECTLY FROM OUR WEBSITE!
<http://www.modelexpo-online.com>