

INSTRUCTION MANUAL

# MODELING THE SOPWITH CAMEL F.1

◆ WORLD WAR I BRITISH FIGHTER AIRCRAFT, 1917 ◆

## Technical Characteristics

Scale:  $3/4" = 1'$  (1:16)

Wingspan: 21" (534 mm)

Fuselage Length :  $14-1/16"$   
(584.2 mm)

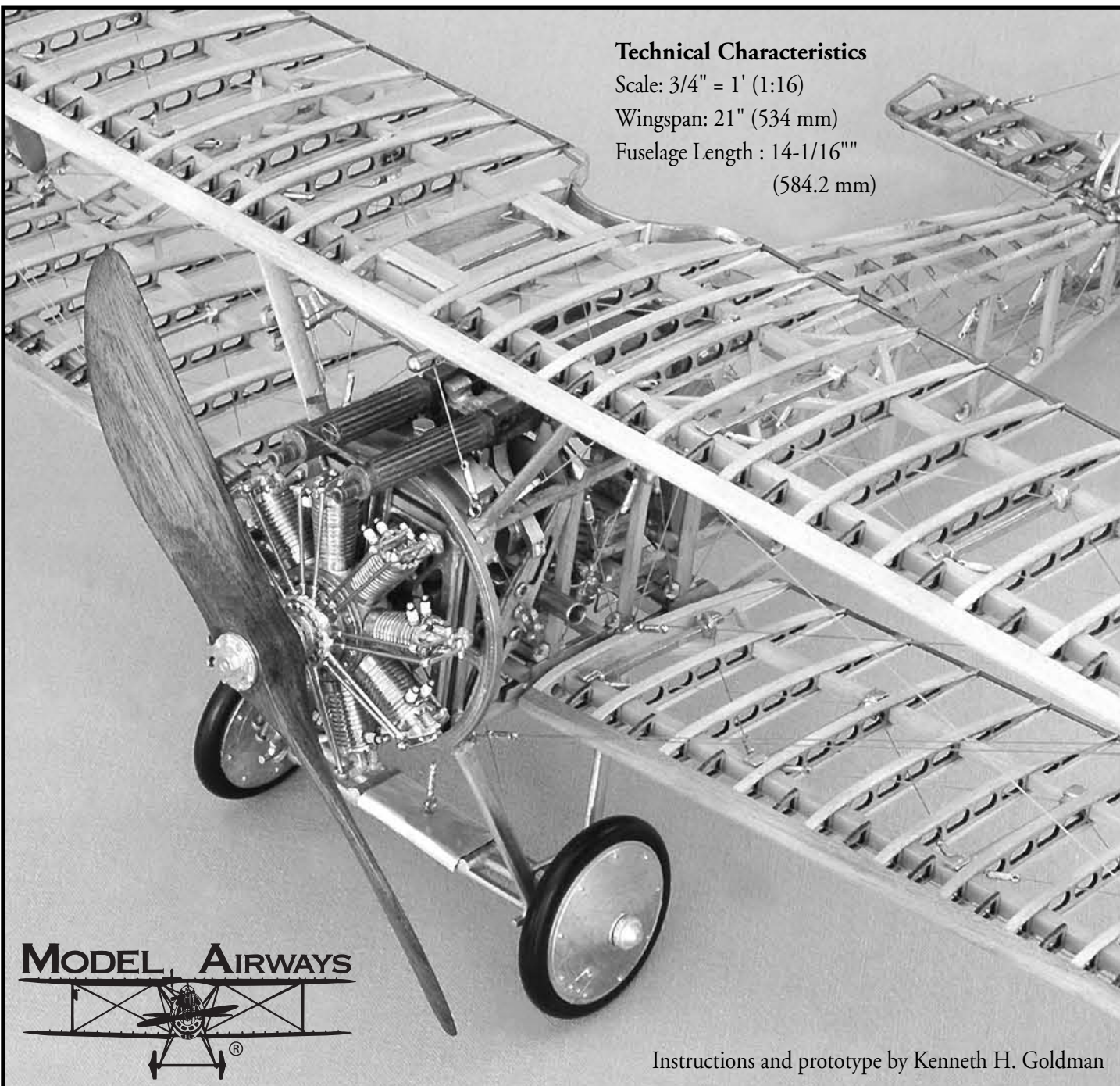

Instructions and prototype by Kenneth H. Goldman

Manufactured by Model Shipways, Inc. dba Model Expo • Hollywood, Florida  
Sold by Model Expo, a division of Model Shipways, Inc.  
<http://www.modelexpo-online.com>

**Model Airways Kit No. MA1030**

# HISTORY

T.O.M. Sopwith made his first solo flight in a Howard Wright Monoplane in 1910 and was forever hooked on aviation. A year later, after setting several records, he opened his own flying school. Not satisfied with other designers' aircraft, he built his first biplane near the end of 1912, and at the beginning of 1913, The Sopwith Aviation Company was in business. Combining his love of things nautical as well as aeronautical, his early production focused on float planes. With the outbreak of the Great War, however, Sopwith's efforts turned to the defense of the United Kingdom.

The company's most famous creation was the F.1 Camel, so named after the humped fairing that enclosed its twin Vickers machine guns each of which was fed by a disintegrating belt of 250 rounds. The prototype first flew in December 1916, and production models entered service in July 1917. The tight grouping of all the weight, including the pilot, between the propeller and the center of the wings made the plane unforgiving in the hands of an inexperienced pilot at low altitude but highly maneuverable at high altitude. Even with this late entry into combat, the Camel accounted for 1,294 victories, more than any other Allied aircraft type. Surprisingly, less than 10% (503) of the total production of 5,497 machines was actually accounted for by The Sopwith Aviation Co. The remainder were built under license by Boulton & Paul Ltd. (1,550), British Caudron Co. Ltd. (100), Clayton & Shuttleworth Ltd. (575), Hooper & Co. Ltd. (321), March, Jones & Cribb Ltd. (175) The Nieuport & General Aircraft Co. Ltd. (400), Portholme Aerodrome Ltd. (300) and Ruston Proctor Ltd. (1,573).

1,342 of the aircraft were equipped with Clerget engines, the rest had either a Gnome, Le Rhone or Bentley. The 130 hp Clerget 9B-powered F.1 Camels had a wingspan of 28 feet and a length of 18 feet nine inches. The aircraft weighed 957 pounds empty and 1455 loaded and could reach a speed of 101 to 113 mph at 10,000 feet. This performance fell off somewhat at altitudes between that and its absolute ceiling of 24,000 feet. Fluid capacity of 26 gallons of fuel and 5.75 gallons of castor oil allowed 2.5 hours of flying time. The rate of climb was five minutes to 5,000 feet and twelve minutes to 10,000 feet.

---

Although a lively dispute continues as to whether Canadian Captain A.R. Brown shot down the Red Baron on 21 April 1918 or whether Australian machine gunners firing up from the trenches fired the fatal shot, there is no dispute that Roy Brown was flying a Sopwith Camel when he chased von Richthofen's Fokker Dr.1 triplane that fateful day. Among the other successful Camel pilots was Captain Arthur Harris, later Air Marshal and architect of the World War II carpet bombing campaign against the Third Reich, which earned him the nickname "Bomber Harris."

The SOPWITH CAMEL model plans and kit were completed in 2005. The model was designed for Model Airways by Microfuzioni - modellismo of Milan, Italy, owned by Luigi Volonté and son Bruno. Model plans and original Instructions in Italian were developed by Luigi Volonté. The text was rewritten in English and expanded by Kenneth H. Goldman, who also built the model.

Copyright 2006 by Model Airways, Inc., a division of Model Shipways, Inc., dba Model Expo • Hollywood, Florida

## INDEX

Technical Specifications .....	Cover	Stage 4: Building The Fuselage.....	13-15
History / Introduction / Credits .....	2	Stage 5: Building The Engine Mount .....	16
Before You Begin.....	3	& Plumbing	
Working with the Plans & Parts .....	3	Stage 6: Building The Cockpit & Controls .....	17-19
What You'll Need to Start Construction .....	3	Stage 7: Epennage Installation & Cabling .....	19-21
Painting & Staining the Model.....	4	Stage 8: Attaching The Lower Wing.....	20-22
Stage 1: Building The Engine & Propeller.....	4-7	& Undercarriage	
Stage 2: Building The Wings .....	7-11	Stage 9: Attaching The Upper Wing, .....	22-25
Stage 3: Building The Empennage.....	23	Cabling & Bracing	
		Stage 10: Finishing Touches .....	26-27
		More Great Model Airways Kits.....	28

## Before You Begin

The SOPWITH CAMEL kit is intended as a structural, non-flying, model without any fabric covering. It is about as close as you can come to being able to hold the real thing in your hand. Most every detail of the real aircraft has been included as model scale permits. Britannia castings and laser-cut wood fittings eliminate creating many parts from scratch, however, some final finishing is required before they are suitable for the model.

Before starting the model, carefully examine the kit and study the plans. Every effort has been made to present the construction stages in a clear, logical sequence. Nevertheless, it is recommended that you think several steps ahead and check the plans accordingly during assembly. This will help clarify what you are doing now and will ensure proper fit of the sub-assemblies later. The instructions will help, but a thorough knowledge of the plans at the outset is essential.

Determine if all the listed parts are present. Handling them will produce a better understanding of the kit's requirements and will help you visualize how every piece will look on the completed model. To avoid losing small fittings and hardware, sort them into labeled containers with lids to keep the parts in and dirt out.

Although each Stage in the instructions results in a completed sub-assembly, it is recommended that you begin at Stage 1 and proceed in order to the finish. Certain modeling techniques are described in full when they first appear in the sequence and only are referred to in subsequent steps. Always complete one construction stage before moving to the next. In addition to the construction figures that accompany the instructions, process photographs throughout will help clarify construction. If things still go awry, take a break, then consider doing them over.

**View color photo on our website!**  
[www.modelexpo-online.com](http://www.modelexpo-online.com)

## Plans

The Model Airways SOPWITH CAMEL is manufactured to a scale of 1:16 or 3/4" equal to one foot. In addition to the Figures that appear throughout this instruction manual, five full-size plan sheets are provided. Each plan sheet is drawn to the actual size of the model except for some areas that have been enlarged to better show detail.

Dimensions can be lifted directly off the full-size plans by using draftsman dividers, a strip of paper laid on the plans on which you make at dot indicating each end of a part, or simply by laying wood strips directly on the plans and marking where to cut them.

## Parts

A parts list is included in each of the construction stages, noting the parts required for that particular stage. A MASTER PACKAGING PARTS LIST (separate from these instructions) is provided that lists the quantities included in the kit. For wood strips, brass rod, wire and rigging, one or several pieces are provided in the kit as noted on the master packaging parts list. These are identified both by size and by the names of the aircraft parts that will be made from them. This material must be cut to length or shape according to plan dimensions. Even though Model Airways supplies enough extra wood to complete the model before running out, it is recommended that you plan to measure and cut the required parts so as to minimize waste. That way you are covered if you make a mistake.

## Cast Metal Fittings

These parts will require final finishing before mounting on the model. Remove mold joint flash with a #10 or a #11 hobby blade, then file or sand with fine sandpaper. Some of the holes through which other parts fit, such as the small eyes of a turnbuckle, may have filled in during the casting process. Carefully clean these out using a drill bit or reamer and check the fit of the other parts. To ensure good glue and paint bonds to these parts, wash off the remaining traces of the mold release agent. A spray of ammonia window cleaner and gentle brushing with an old soft-bristle toothbrush does the job nicely. Thoroughly rinse the parts and allow them to dry.

## Necessary Construction Tools

The following tools and supplies are recommended for the construction process. Modelers who have built before may have their own favorites.

### A. Knives and saws

1. Hobby knife with No. 11 and No. 10 blades

2. Razor saw

### B. Files - Set of needle files

Flat, fine-tooth, mill bastard file

Round riffer file

### C. Clamps and Pins

1. Assorted Bulldog clips

2. Wooden clothespins

3. Rubber bands

4. Package of T-pins

### D. Boring Tools

1. Set of miniature drills (#60 to #80)

2. Pin vice

3. Standard set of twist drills

### E. Miscellaneous

1. Tweezers (a few)

2. Small fine pointed scissors

3. Miniature pliers

a. small round

b. flat nose

4. Wire cutters

5. Mechanics rule graduated in 1/64"

6. Brass brush for polishing cast parts

7. Small block plane (for shaping wing leading edges)

### F. Sandpaper

#120 aluminum oxide paper for shaping wood parts

#200 wet/dry silicon carbide paper for intermediate sanding

#400 wet/dry silicon carbide paper for fittings and finishing

### G. Glue

Yellow (tan) carpenter's glue for wood parts  
Cyanoacrylate (CA or Super Glue) for metal parts, metal to wood, and rapid assembly of wood parts.

### 3. OPTIONAL

Cyanoacrylate De-Bonder (just in case you have to take something apart)

Cyanoacrylate Accelerator for an instant bond  
Five-minute epoxy provides extra strength for gluing fittings.

### H. Building Board

A soft, but stiff board such as acoustic ceiling tile or insulation wallboard to easily take straight pins for holding parts during assembly. This soft board should be nailed or glued to a hard board so it will be flat. You can use a table, but a portable board is good for turning it around to make the work easier. You will also need assorted scrap lumber, as indicated on Plan 05 to build some of the suggested special jigs.

## Setting Up The Plans

It is easiest to build flat subassemblies directly on the full-size plans. Place the plan on your building board and cover it with waxed paper or plastic wrap. Be careful applying glue, especially super glue. Although the waxed paper or plastic wrap protects the plan somewhat, you could accidentally glue the protective sheet to the model parts, or even to the plan itself.

An alternative, if you have a dedicated modeling area, is to lay a sheet of glass over the full-size plan sheet and build directly on the glass, using tape and weights to hold the parts in position. If you use this method, watch out for sharp edges on the glass.

## Getting Started

Before commencing each stage of construction, have all the parts for that stage identified and ready to use. It helps to lay each part on its corresponding location on the full-size plan to facilitate identification as you proceed. Lightly sand wood parts as required to remove any fuzziness and prepare the castings parts as noted above.

## Painting and Staining

Your Sopwith Camel model need not be painted or finished at all. However, it is recommended that you seal the wood parts and Britannia castings for protection. Due to the

intricacy of the finished model, this is best done as you go. Using carpenter's glue on raw wood allows the strongest bond, but inevitable glue smears and runs leave the wood essentially impervious to staining, and end grain will stain darker than the rest. A good compromise is to airbrush or brush varnish onto completed wood subassemblies, followed by a tinted coat to even out the color or darken the tone, followed by a finish coat of varnish to even out the gloss. The first, sealer coat, is especially important if you use water base products.

Britannia castings parts may be left polished or painted a steel or gunmetal color, or as suggested during construction. Sparkplug insulators can be painted white. Other fit-

tings, such as turnbuckles and instruments castings, can be painted black. Varying the tones on the various parts will add a nice contrast to the finished model.

The distinctive wicker seat back is provided as a Britannia casting to simplify construction. You will need to paint this, after gluing it to the seat, to give it an appropriate rattan finish. A tan base coat followed by light and dark washes will give you a good effect.

After you have shaped and finish sanded the laminated propeller, you can achieve a more authentic look by staining it golden mahogany and then building up two or three thinned layers of varnish or shellac.

## STAGE 1: BUILDING THE ENGINE AND PROPELLER

Although a counter-intuitive design by today's standards, fixing the propellers to a spinning engine on a stationary crankshaft simplified cooling, had an excellent weight to horsepower ratio and allowed greater flexibility in locating the aircraft's center of gravity – affecting maneuverability - over the in-line engines of the time. One drawback, however, was the pronounced gyroscopic effect that pulled the aircraft to the right. To fly in a straight line, pilots had to compensate for this by applying constant left rudder.

The Clerget rotaries provided improved speed control over the Gnome and Le Rhone rotaries by replacing the standard “blip” switch that temporarily grounded the magneto (killing the ignition) with a selector switch that restricted the engine to run on 9, 7, 5 or

even 3 cylinders. Like the earlier rotaries, the Clerget spewed unburned castor-oil from the exhaust, adding to the pilot's discomfort. Pilots were issued a small bottle of blackberry brandy to counteract the smoke's laxative effect.

The completed engine subassembly slips onto the fixed crankshaft at a later construction stage. Super glue and/or epoxy should be used to assemble the parts. Care must be exercised with the many small parts. Refer to Figures 01 through 05. For clarity, drawings may show a single cylinder. It is a simple matter to repeat the assembly for the other eight cylinders. The key to success is to carefully clean up all of the castings and then to dry fit everything before applying glue.

### Parts List For Stage 1

WP129K-1.5	Crankshaft tube	1	3/16" diameter x 1-1/2" brass tube	CLE12	Cylinder heads	9	Britannia castings
CLE02	Crankcase	1	Britannia casting	WP162-1.2	Valve lifters	18	15/16" x 1/16" d. brass rods
CLE03	Crankcase covers	2	Britannia castings	GS2-3	Tappet seats	18	Small brass eyelets
CLE04	Front propeller flange	1	Britannia casting	CLE15i	Intake rocker arms	9	Britannia castings
CLE05	Rear propeller flange	1	Britannia casting	CLE15e	Exhaust rocker arms	9	Britannia castings
CLE06	Camshaft box	1	Britannia casting	CLE16	Induction pipes	9	Britannia castings
CLE07	Induction box	1	Britannia casting	CLE17	Propeller	3	Laser-cut basswood 5/32" thick
CLE08	Igniter ring	1	Britannia casting	WP1218	Ignition wires	9	cut from 72" black thread
CLE09	Spark plugs	18	Britannia castings				
CLE11	Cylinders	9	Britannia castings				

### Engine group:

Begin by attaching the front and back crankcase covers (CLE-03) to the crankcase (CLE-02). Note that there are tiny notches in the castings to help you align the parts. Glue one side in place, then make sure the bolts heads line up on both covers before gluing the second cover in place. Slip this subassembly onto the crankshaft tube, which you must cut from (WP129K-1.5) to ensure that the engine parts line up properly, but do not glue the cast parts to the tube at this stage.

Slip the nine cylinders (CLE-11) over the pistons on the crankcase so that the paired

sparkplug holes all face the same way, perpendicular to the central axis of the crankcase. Now hold the subassembly facing you so that the sparkplug holes are to the left on the cylinder at the top. This is the front of the engine. Slip the camshaft box (CLE-06) onto the brass sleeve and align it so the paired depressions for the tappet seats (GS2-3) are centered in front of each cylinder. Looking at the top cylinder, the left hand of each pair should be closer to you. Glue CLE-06 against the crankcase. For the best fit of the tappet seats (GS2-3) later on, use a 3/32" twist drill to clean the 18 depressions in CLE-06. Finish up with a quick twist from a

7/64" drill to bevel the edges. Be careful not to drill too deep.

Refer to Engine Photograph 1 to align the cylinder heads (CLE-12) on the cylinders before you glue them in place. NOTE that the two flats on the top do not match: the larger one, with straighter sides, also has the larger hole; it is for the intake rocker arm, which goes to the side opposite the sparkplug holes. The flats should line up with the central axis of the engine, which will set the two holes at an angle to that axis. Next, glue the intake rocker arms (CLE-15i) to the cylinder heads so that the flanged pipe on each goes to the rear of the engine.

Slip the induction box (CLE-07) onto the brass tube at the rear of the engine. Referring to Engine Photograph 2, holding an induction pipe (CLE-16) in place, flanged end against a flat on the CLE-07, position the flat on the induction box so that the flat side of the other end of the pipe meets the center of the flanged pipe on the intake rocker arm. Properly aligned, it will be at a slight angle. Glue CLE-07 to the crankcase. Dry fit each induction pipe and adjust the flat as necessary to fit against the pipe on each CLE-15i and glue them into place. File off any part of each induction pipe that extends above the edge of the flanged pipe on parts CLE-15i.

Glue the igniter ring (CLE-08) to the induction box so that the holes line up between each pair of cylinders and the small gear faces away from the engine. Now glue the engine subassembly to the crankshaft tube so that one end of the tube is flush with the outer surface of the small gear on the igniter ring. Glue the exhaust rocker arms (CLE-15e) in place on the cylinder heads. Cut the 18 valve lifters (CLE-13) from the provided lengths of 1/16" brass rod. It is suggested that you cut them to 15/16" and then file them down to achieve the best fit. Slide a tappet seat (CLE-14) onto the brass rod and glue into place, referring to Engine Photograph 3.

Complete the engine group by attaching the ignition wires (WP1218) from the igniter ring to the spark plugs, referring to Engine Photograph 4. Cut 18 4" lengths of black thread. Feed each pair of threads through one of the nine holes in the igniter ring and tie them to the sparkplug terminals. Alligator clips or other small clamps can be used on the thread ends that emerge from the hole to act as weights to keep the threads taut as you fix them and the knots with a drop of glue. Trim off the excess thread and repeat the process for the other eight cylinders.



Engine Photograph 1

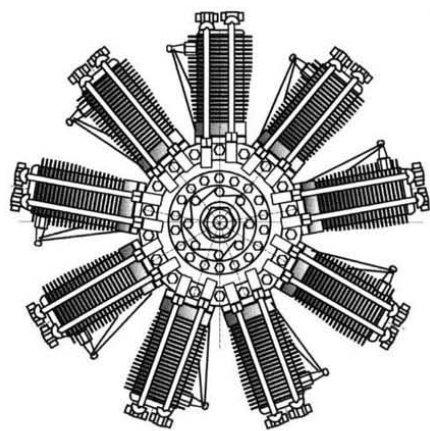
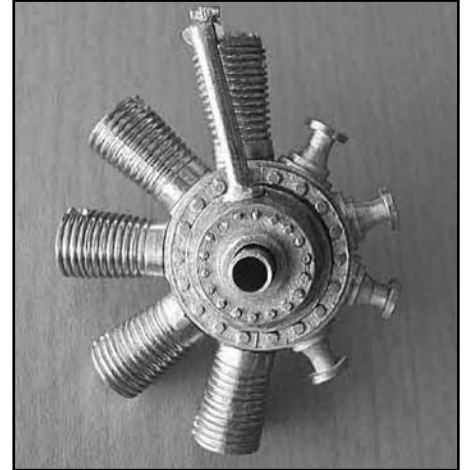
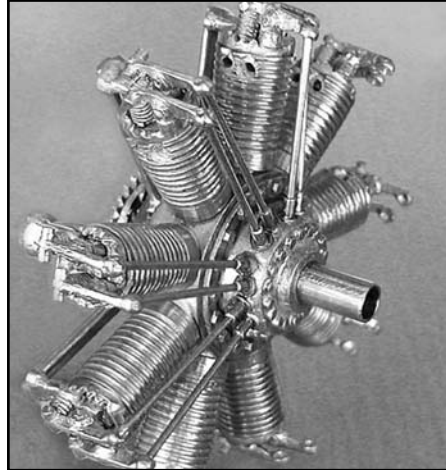
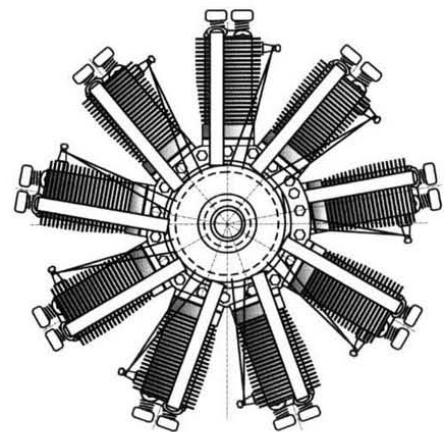
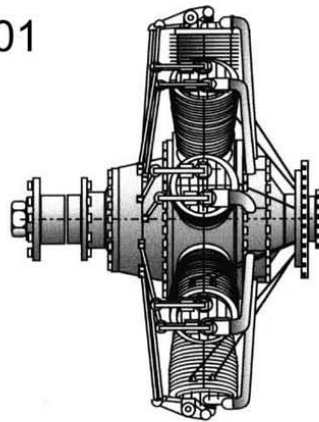

Fig.01



front view

Fig.02

[prop hubs]

CLE04

CLE05

CLE06

CLE03

CLE02

CLE03

CLE07

CLE08

Fig.03

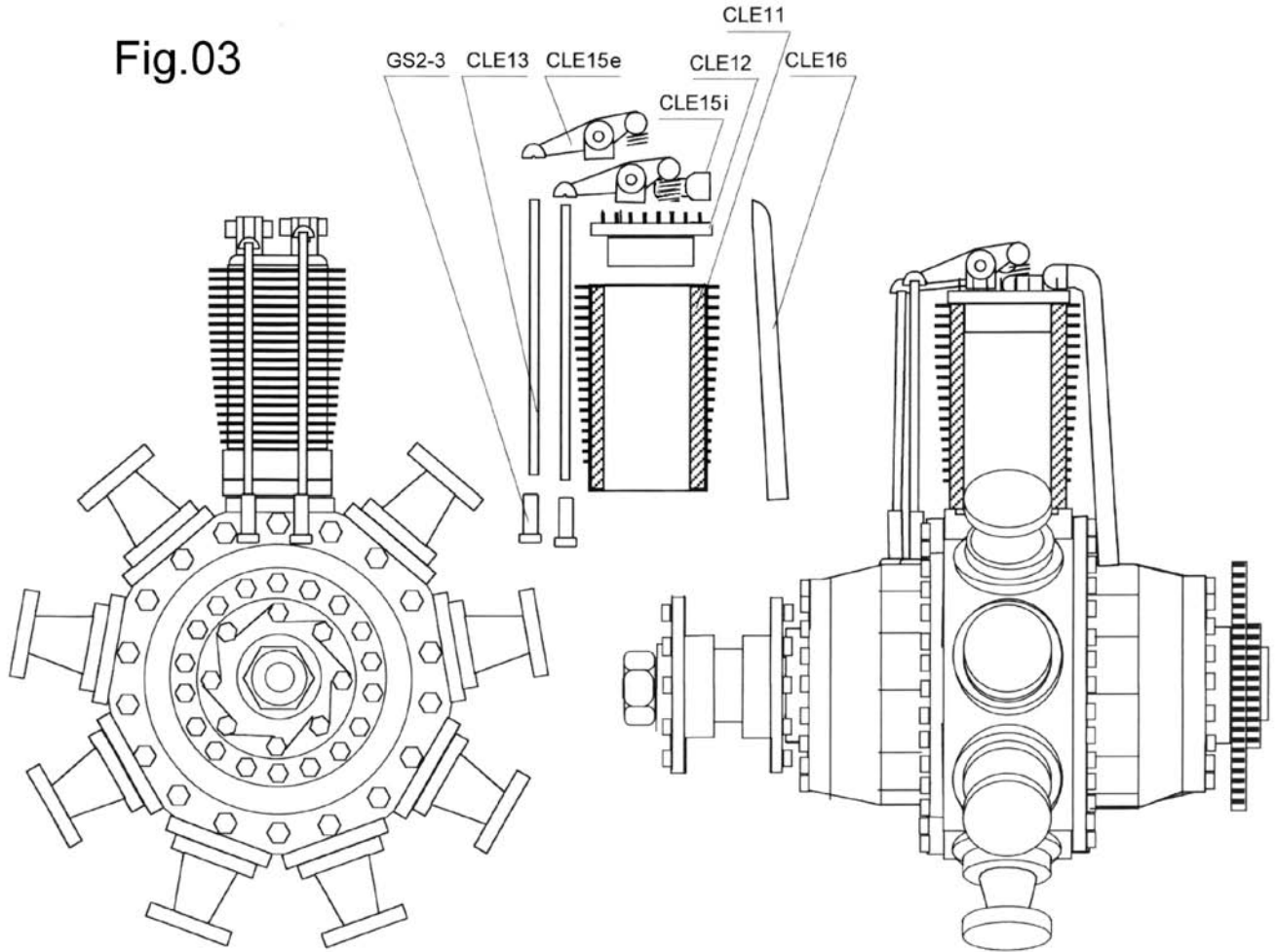
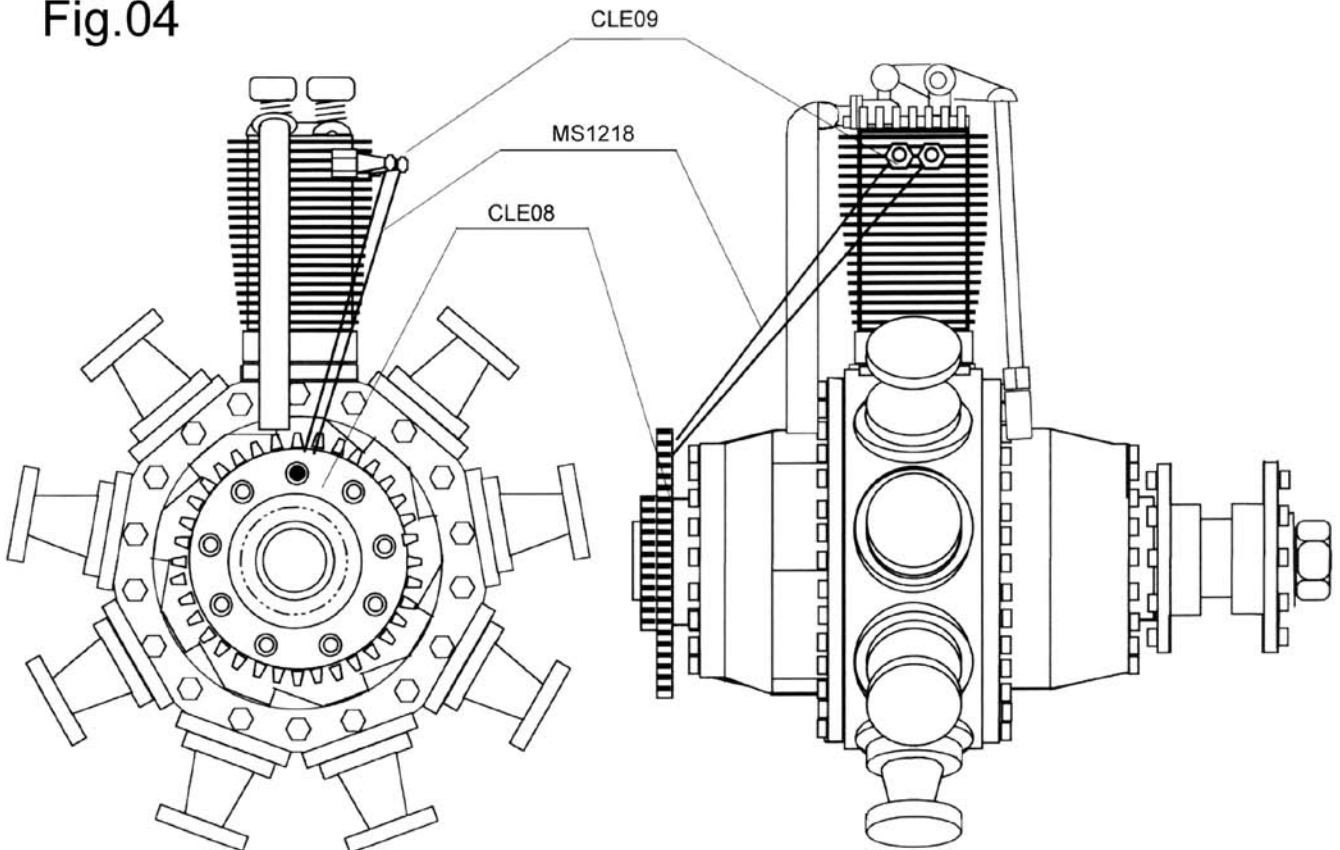

Fig.04



### Propeller group:

Referring to Fig.05, laminate the propeller layers (CLE17). Take care to stack the layers in the correct order. When viewed from the front in a vertical position, the stack goes from longest to shortest with the shortest layer closest to you. Curved edges would then be upper left and lower right. A 1/4" diameter bolt and nut make a handy center clamp that helps align the layers while the glue dries.

Remove the bolt and whittle and sand the propeller to its refined shape. The front of the finished propeller curves toward the back when viewed from the side. Begin with the overall lengthwise curve, then proceed to the cross-sectional shaping. This will result in a curved leading edge and a straight trailing edge after the final shaping. Shape the front first, then the back to follow the front. Note that the front surface is slightly convex and the back is slightly concave.

When you are satisfied with the result, apply a gold-mahogany stain. If using a water-base stain you might have to lightly re-sand the propeller with #400 paper to remove any raised wood grain, then apply a couple of coats of varnish.

Attach the front (CLE04) and rear (CLE05) flanges to the propeller. Make sure the front and rear bolt heads/nuts line up before gluing. Dry fit this assembly onto the crankshaft mount. There should be a space of about 1/16" between the rear propeller flange and the camshaft box.

**DO NOT** glue the propeller to the crankshaft mount until final fitting of the engine to the completed aircraft. This will allow you to make any needed adjustment so the prop will clear the machine gun muzzles.

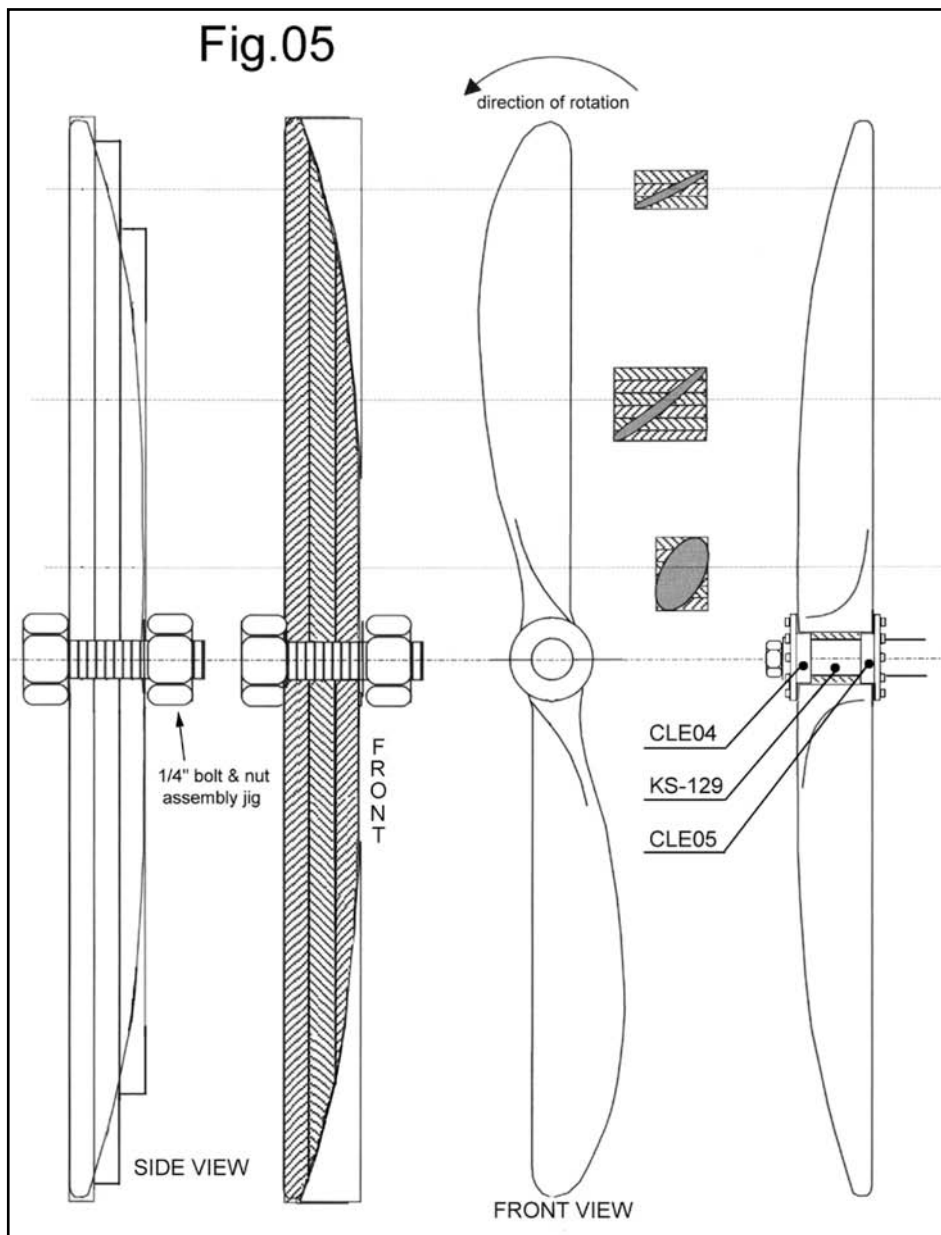

## STAGE 2: BUILDING THE WINGS

The upper and lower wings are built in essentially the same manner, referring primarily to full-size Plan 03. The primary differences are

the center trailing edges and that the lower wing will be cut in two and rejoined to create its correct dihedral angle.

### Parts List For Stage 2

CAW01	Ribs	2	laser-cut plywood 3/64" thick	CAW20	Compression bars	15	Britannia castings
CAW02	Ribs	28	laser-cut plywood 3/64" thick	CAW21a/b	Aileron hinges	12	each Britannia castings
CAW03	Ribs	8	laser-cut plywood 3/64" thick	CAW22	Aileron horns	4	Britannia castings
CAW04	Ribs	4	laser-cut plywood 3/64" thick	CAW23	Aileron cable anchors	4	Britannia castings
CAW05	Ribs	16	laser-cut plywood 3/64" thick	CAW24	Aileron pulleys	4	Britannia castings
CAW06	Ribs	4	laser-cut plywood 3/64" thick	CAW25	Compression bars w/eyes	6	Britannia castings
CAW07	Ribs	4	laser-cut plywood 3/64" thick	CAW38	Front lower wing joint	1	Britannia casting
CAW08	Nose ribs	50	laser-cut plywood 3/64" thick	CAW39	Rear lower wing joint	1	Britannia casting
CAW18	Wingtips	4	Britannia castings	W042	Turnbuckles	36	Britannia castings
CAW19	Top center trailing edge	1	Britannia casting	WP3603	Rib caps		1/32" x 3/32" basswood strips

## Parts List For Stage 2 (continued)

WP3671	Leading edges	5/32" x 3/16" basswood strips
WP3648	Front spars	5/32" x 5/32" basswood strips
WP3631	Rear spars	1/8" x 1/8" basswood strips
WP3625	Front aileron spars	3/32" x 3/32" basswood strips
WP3618	Rear aileron spars	1/16" x 1/16" basswood strips
	Wing braces	
WP1205	Rigging cable	Metal-gray thread
WP161K	Wing trailing edges	3/64" brass rod
WP0976	Trailing edge bands	1/4" Adhesive copper tape

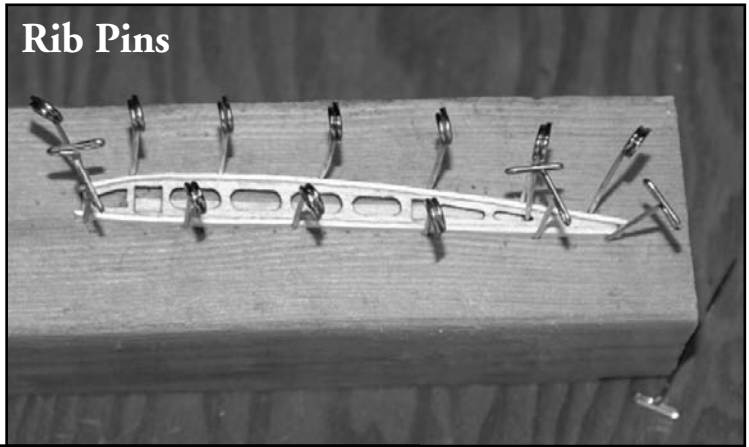

**Note: Upper wing spars of 12" must be joined in the center to make the full wingspan**

### Wing ribs; rib caps:

After cutting loose all of the above referenced ribs, lightly sand them to remove surface char from the laser, then sort them by number.

To facilitate making the cap strips overlap ribs CAW02, 04, 05, 06 and 07 equally to each side, make a simple jig by gluing a 2 1/2" length of the 1/32" x 3/32" rib cap stock to a scrap block of soft wood, as in Fig.06. Pin the rib to be glued onto the strip through some of the cutouts, apply carpenter's wood glue to the rib edge and use T-pins against the rib cap to clamp the cap to the rib. Repeat for the opposite edge. Note the photograph "Rib Pins". Use of a hair drier will speed up the process. The "waist" on ribs CAW05 and CAW06 make them particularly fragile, requiring extra care when gluing on their cap strips.

The 8 parts CAW03 are laminated in pairs to make 4 double-thick ribs before cap strips are glued on, and the 2 ribs CAW01 are glued flush to one edge of the cap strip to make left and right capped ribs. Fig.06 shows the left hand one (looking from back to front of the finished airplane). Therefore, instead of using the jig, lay a piece of waxed paper on the scrap wood to avoid gluing those ribs to it.

### Inserting the spars; leading edges; nose ribs:

Slight variation in the provided wood strips is to be expected, therefore test fit all of the spars, including the aileron spars, to the ribs and sand down the spars as needed to attain a snug fit.

Referring to Plan 03.1, slide all of the upper wing ribs, except CAW 06, 07 and 08 onto the front (5/32" square stock) and rear (1/8" square stock) spars. Make sure that the flush sides of ribs CAW01 face the center of the wing. Once everything is lined up, glue the ribs into place using a small brush and thinned wood glue.

Once the glue is dry, cut the front spar to length and taper the ends outboard of the first rib at each end to fit the narrower slot in ribs CAW06 and glue those ribs in place.

Insert the aileron spars (3/32" and 1/16" square stock) through the holes in ribs CAW05 and 06, then glue and cut to length according to the plan. Attach aileron rib CAW07, being careful to leave a gap between it and the next inboard rib. This will allow the ailerons to move when they later are cut free. Locate the wing angle braces on Plan T.03. Cut them from 1/16" square lumber and glue into place.

Dry fit the leading edge lumber (5/32" x 3/16" x 24") against the front edge of the ribs to check for uniform fit and to make sure that the nose ribs (CAW08) will fit snugly between the front spar and the leading edge. If necessary, use a long strip of sandpaper, affixed to the same length straight, flat piece of wood, to lightly sand the leading edges of the ribs.

Trim spar ends and notch them, using a round needle file, to fit the wingtips CAW18. You also will need to file a notch in the front spar rib CAW05 meets it. File and bend the wing tip if needed so that all ends make contact with the spars and ribs. Glue the wing tip in place using CA and repeat for the other wing tip.

Next, hold the 3/16" side of the leading edge lumber in place to determine its proper length and where to cut notches to fit over the end of the wing tip casting – see Fig.10. Before gluing the leading edge to the ribs, locate the aileron pulleys (CAW24) on Plan 03 and drill the appropriate holes in the leading edge of the front spar. Glue the leading edge in place and taper the ends down to the wingtips from the last rib the leading edge attaches to. Glue the leading edge in place, 3/16" edge against the ribs and carefully sand it to a rounded profile, as in the ribs cross-sections on Plan 03. Careful use of a block plane will speed up the process. Glue the nose ribs in place. Now is the time to varnish and tint the wing assembly. Although later steps will expose unvarnished edges, these can be touched up with a brush.

Finally, build the lower wing to the same stage of completion and saw apart per Plan 03.2.

### Compression bars; pulleys; trailing edge; visibility cutout; rigging:

Glue the aileron pulleys in place using CA glue.

Drill #75 size holes through both ends of the compression bars (CAW20 and 25) where the round flange meets the angle bracket – see Fig.12 detail. Next, locate and glue the compression bars in place, hanging bars CAW20 from the top and attaching CAW25 from the bottom, so the eyes point down from the upper wing. All of the compression bars are hung from the top in the lower wing, which positions the eyes on CAW25 pointing up. It is important that the outboard upper and lower parts CAW25 line up on the two wings, because this is where the wing struts will attach.

To frame the visibility cutout in the upper wing, first make sure that tabs that overlap the spars of the center compression bar are filed down to a maximum of 1/32" thick. Next cut four 9/32" lengths of 1/32" x 3/32" wood strip and glue these supports to the front and rear spars edges, against ribs CAW01, so that they extend from the outer spar edges into the center space. Cut six roughly 3/4" lengths of the same wood and plank three of them onto each pair of supports.

The easiest way to rig the wing bracing wires is to run a continuous length of WP1205 thread from one end of the wing to the other and then repeat the process to create the X-pattern on Plan 03. Each time you come to the front end of a compression bar, slip a turnbuckle (W042) onto the thread, through both holes, before running the thread through the holes you drilled in the compression bars. After stringing the thread all the way to the opposite end of the wing, secure the end, then gently tighten the thread, working backward to where you started. At each front end of a compression bar, slide a turnbuckle up to the bar then secure the thread and turnbuckle with CA glue. At each rear end of a compression bar secure the thread with CA



glue. The procedure basically is the same for the lower wing, except each half is rigged separately.

Although this rigging technique provides generally acceptable results, the more demanding modeler might prefer to knot the thread through each turnbuckle eye in lieu of using a continuous run.

The casting for the upper wing's center trailing edge (CAW19) requires some adjustment for a good fit. Cut the long pins at the ends so that they nestle between the cap strips where they meet ribs CAW02. You might have to file the pins out of round to achieve the best fit. Sand the ends of ribs CAW01 if needed, then glue curved section of CAW19 to the end of the center ribs so that 3/64" of the casting extends beyond the trailing ends of ribs CAW02. This provides an end seat for the 3/64" brass rod which is used to make the wing's trailing edge. See Fig.11. Cut the brass rod to length before attaching it with CA glue, and leave a gap between the wing and the

ailerons – Plan 03. Finish off the trailing edge by wrapping the joints with 1/2" lengths of copper tape, cut to the width of the rib cap strips. Use four 1/4" long copper strips to cover the top and bottom joints between ribs CAW01 and the center trailing edge.

Carefully separate the ailerons from the wings by sawing through the ribs between the rear wing spar and the front aileron spar. Continue the cut through the wing tip casting and sand as needed. Referring to Plan 03-1 and Fig.13 attach the hinges CAW21 a&b. The gudgeon half (has hole) attaches to the rear wing spar and the pintle half (has pin) attaches to the front aileron spar. In order to lock the aileron to the wing, arrange the hinges so the pintles of the middle and outside hinges face the aircraft center line and that of the inside hinges face toward the wingtips.

Locate the aileron horns CAW22 and the aileron cable anchors CAW23 on the ailerons as indicated in the drawings. The

horns angle forward and are placed atop the upper wing and below the bottom wing. Before gluing in place, notch the rib cap where each part goes so that the vertical tab snugs up against its laser-cut rib.

### Joining the lower wing halves:

Create the lower wing dihedral by tapering the bottom ends of the front and rear spars so that when they are rejoined by parts CAW38 and CAW39 they will lie flat within the cast joints and the underside of the outermost ribs(CAW06) will be elevated 25/32" above the work surface. Reference Plan 03.3. The easiest way to ensure both sides come out the same is to cut blocks of the right thickness to hold up the wing ends while you gently push down on the center joints. Before gluing this together, check that the space between the inside flats of the innermost ribs (CAW03) is 1 13/16".

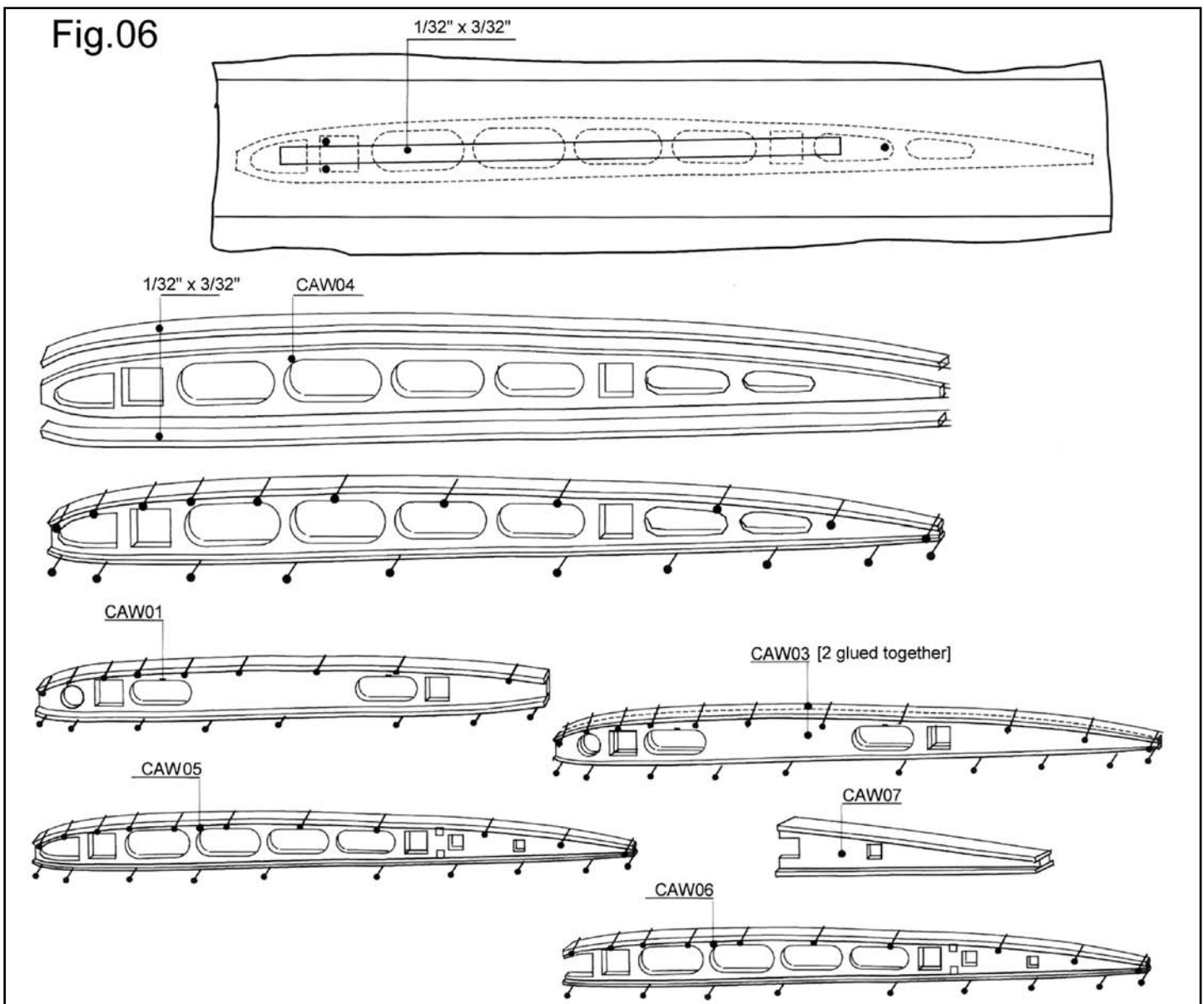

Fig.07

center of upper wing

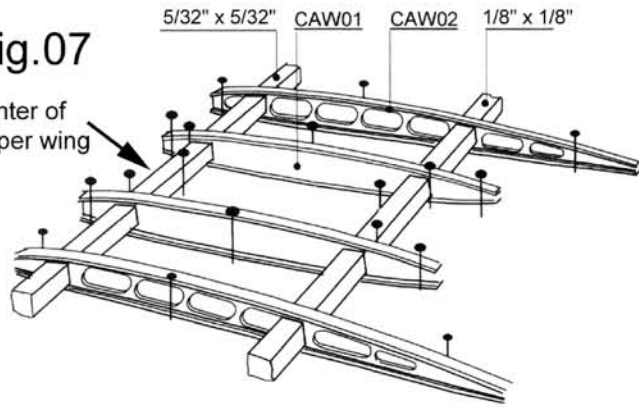

Fig.08

left lower wing

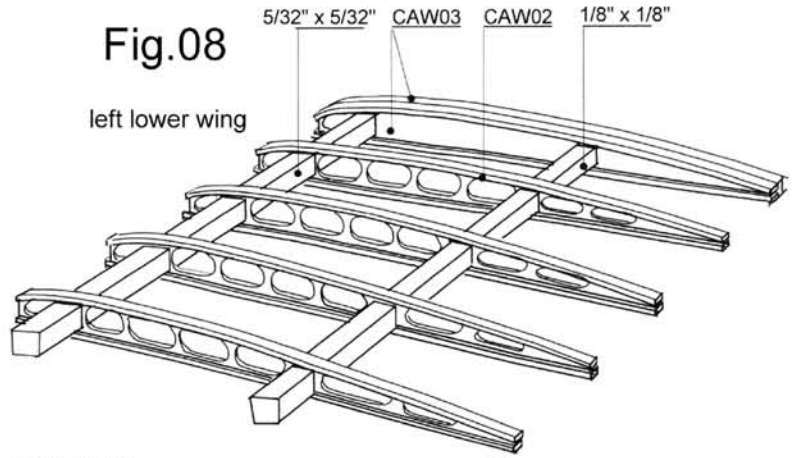

Fig.09

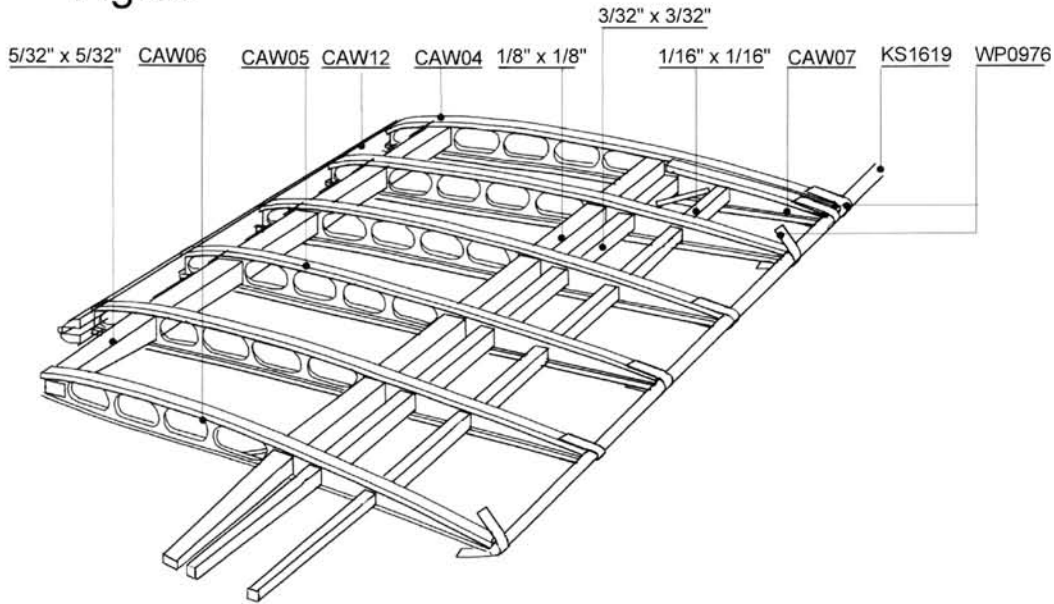

Fig.10

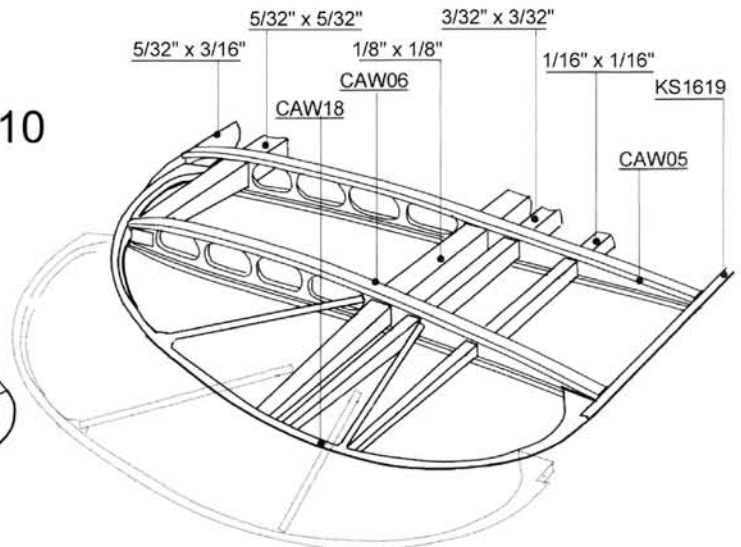
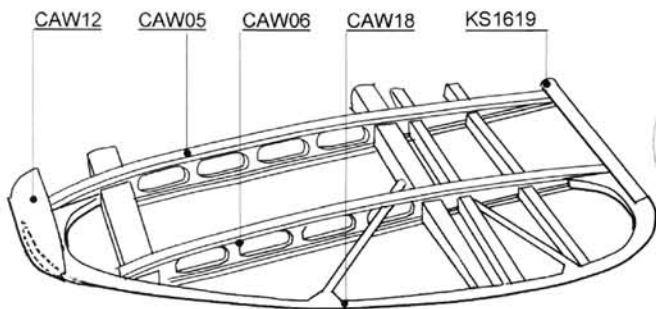

Fig.11

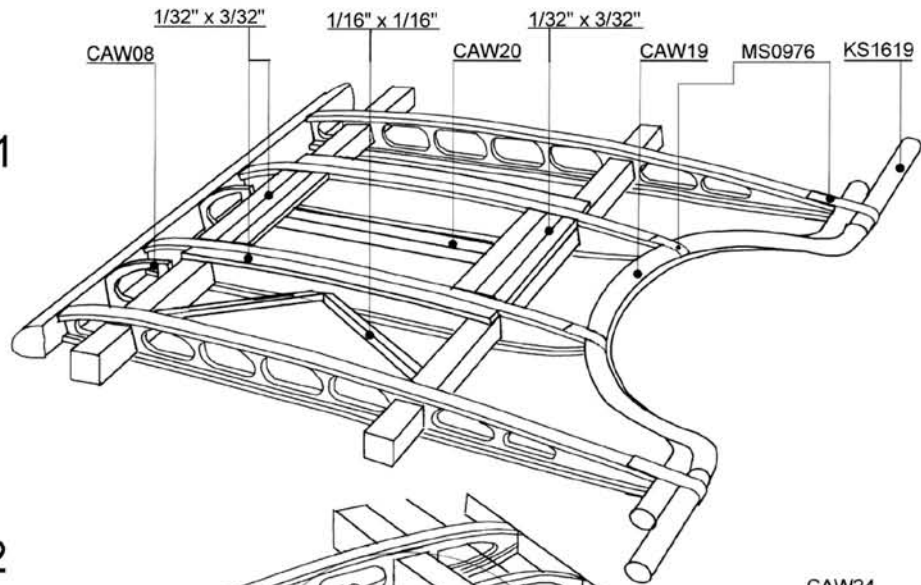
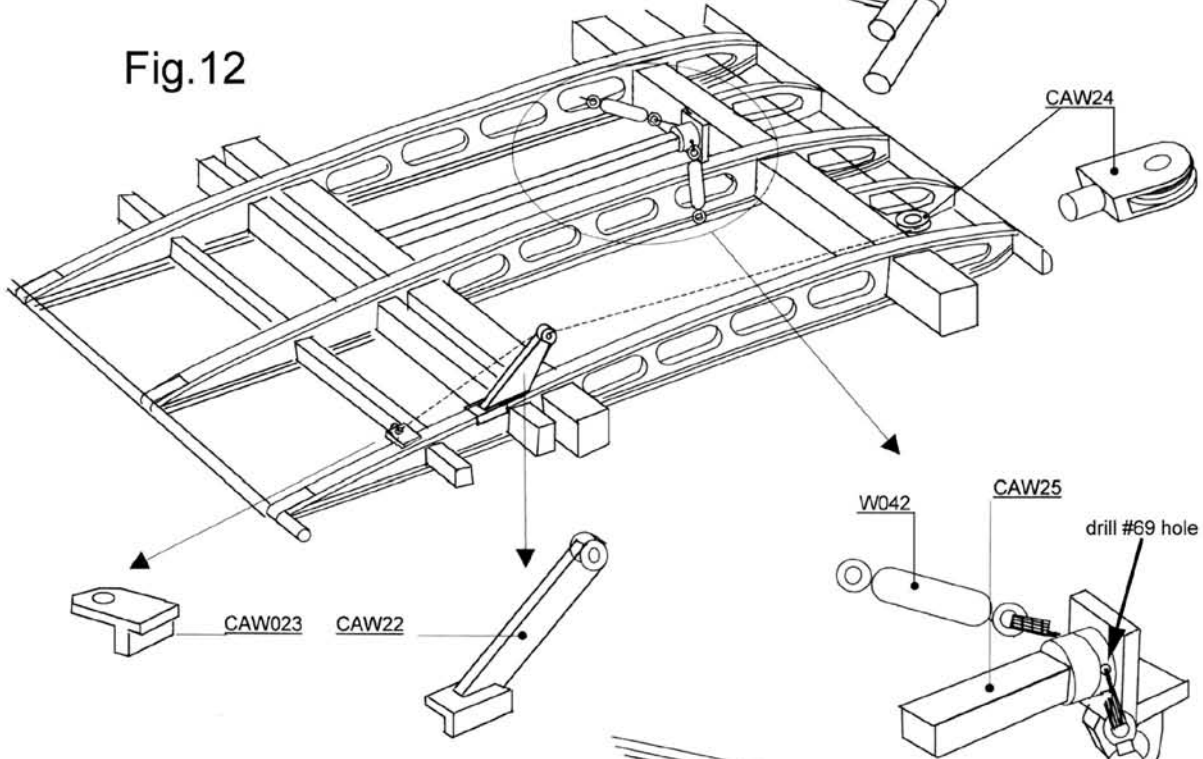

Fig.12



1/8" x 1/8"

3/32" x 3/32"

CAW21a & b

Fig.13

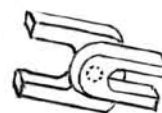

CAW21b

CAW21a

## STAGE 3: BUILDING THE EMPENNAGE

### Parts List For Stage 3

CAW09	Horizontal stabilizer ribs	8	laser-cut plywood
CAW10	Stabilizer nose ribs	6	laser-cut plywood
CAW32	Elevator and rudder hinges	7	Britannia castings
CAW33	Horizontal stabilizer rim	1	Britannia casting
CAW34	Elevator	1	Britannia casting
CAW35	Elevator and rudder horns	3	Britannia castings
CAW36	Vertical Stabilizer	1	Britannia casting
CAW37	Rudder	1	Britannia casting
W042	Turnbuckles	4	Britannia castings
WP3603	Rib caps	1/32" x 3/32"	basswood strips
WP3625	Horizontal stabilizer spar & Stabilizer compression bars	3/32" x 3/32"	basswood strips
WP1205	Rigging cable		Metal-gray thread

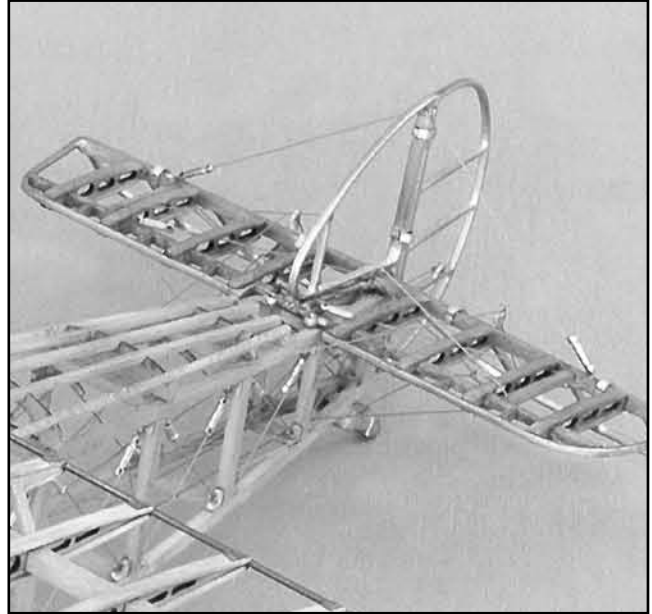

### Horizontal stabilizer and elevator:

As you did for the wings, glue cap strips onto the eight horizontal stabilizer ribs (CAW09). Drill #75 holes in CAW33 where indicated on Plan 03.4 for stringing the cross bracing rigging.

Referring to Plan 03.4, use 3/32" square lumber to make the stabilizer spar. File a rounded notch in each end for a tight fit to the stabilizer casting (CAW33). String the ribs onto the spar, then position the ribs and spar within the casting and glue everything in place. Attach the six nose ribs.

Cut the stabilizer compression bars from 3/32" square lumber, notch the ends for the cross bracing rigging ends and glue into place. Using turnbuckles (W042), where indicated in the drawing, rig the cross bracing (WP1205) in the same manner you chose for the wings.

Glue on the two elevator horns (CAW35) where indicated in Fig.14, making sure that the ends angle forward. Referring to Fig.15, attach the elevator to the stabilizer by crimping four CAW32 hinges over the notched areas. **DO NOT USE GLUE.**

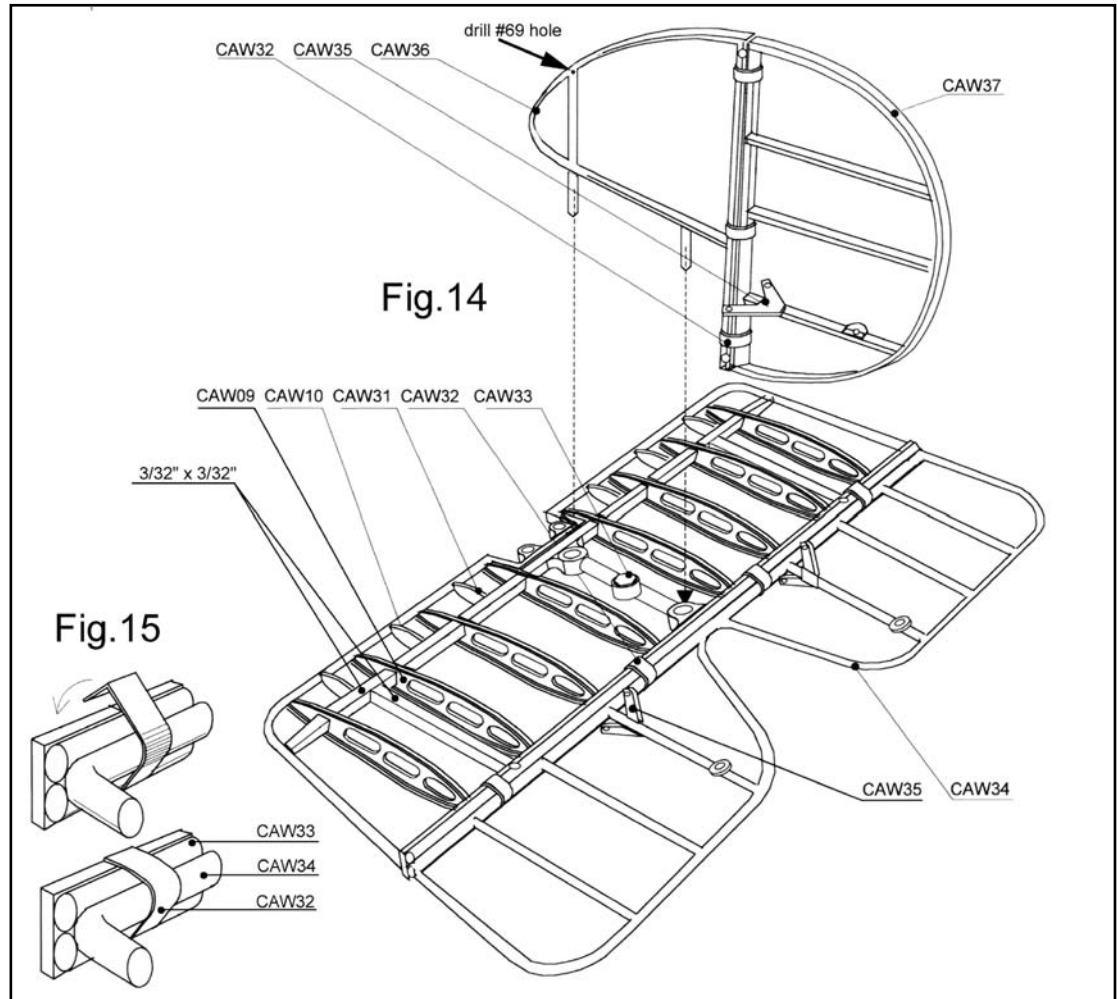

### Vertical stabilizer and rudder:

The vertical stabilizer (CAW36) and rudder (CAW37) are complete castings except for the rudder horn (CAW35) which must be glued in place with the angled horns facing forward. You will need

to drill a #75 hole through the top of the front vertical brace in the rudder (Fig.14) to accept rigging when the empennage is attached to the fuselage. Attach the rudder to the vertical stabilizer by crimping three CAW32 hinges as indicated. **DO NOT USE GLUE.**

## STAGE 4: BUILDING THE FUSELAGE

Although it is possible to construct the fuselage atop the full-size plans, as you did with the wings, several construction jigs are depicted on plan sheet 05 to facilitate assembly. If you opt to build the sides without a jig, it is important that you are consistent in aligning the wood strips with the same edges of the drawing. For example, if

you lay out the vertical frame members for one side along the left edge of the vertical frames in the drawing make sure you do the same for the other side of the fuselage, otherwise milling differences in kit lumber and different printed line widths could cause discrepancies between the two sides.

### Fuselage:

Laminate pairs of parts CAF03 to form the two cockpit base structures. Laminate the two parts CAF06 to make the single nose frame. Form the two diagonal mounts by laminating a solid laser cut CAF04 to one with lightening cutouts for each.

Using Plan 02.2 or Jig 4 on Plan 05 glue up the fuselage sides using CAF03 and 3/32" X 3/32" wood strips. The top and bottom longerons are continuous strips that will bend easily. Take measurements from Plan 02.2. Glue in the diagonal mounts (CAF04), making sure that the sides with the lightening cutouts face outward, then glue on the rigging eyes (CAF05) so the flat backs of the eyes face inward.

**NOTE:** It is crucial that the three small holes on CAF04 line up across the fuselage later on when installing the engine mount and plumbing. If you opt not to use Jig 4, it is recommended that you install parts CAF04 after building the complete fuselage. Dry fit the parts and insert a rod or dowel through one pair of holes and then adjust the fit before gluing so the rod is both level and perpendicular to the fuselage centerline.

Using Plan 02.1 (helped by Jig 5 on Plan 05 if desired) attach the two sides by first joining them to the doubled nose frame CAF06 and then reinforcing this with horizontal formers at position "A". Attach horizontal formers at positions "D", noting that there are no top formers at positions "B" and "C".

The remaining horizontal formers should be cut to length to match the spacing of the associated false frames at positions "E" through "H". When the glue is dry, glue together the two tail ends before fitting the horizontal formers at position "I". Use the 3/32" square kit lumber to make the final fairing support CAF22. Attach this across the top of the fuselage and round the corners. Make the fairing stringers out of 1/16" square kit lumber and fit them to the notches in the false frames, gluing the tail ends atop CAF22.

Referring to Plan 02.3, attach the angle braces (CAF12) inside frame "B" and the fairleads/angle braces (CAF13) inside frame "D". The inside corner of CAF12 and CAF13 support the seat rails which are cut from 3/32" square stock of about 3 5/16" length. Before gluing the rear seat rail support (3/32" square wood) across the

### Parts List For Stage 4

CAF03	Cockpit base	4	laser-cut plywood
CAF04	Diagonal mounts	4	laser-cut plywood
CAF05	Rigging eyes	64	Britannia metal
CAF06	Nose frame	4	laser-cut plywood
CAF08	False frame "E"	1	laser-cut plywood
CAF09	False frame "F"	1	laser-cut plywood
CAF10	False frame "G"	1	laser-cut plywood
CAF11	False frame "H"	1	laser-cut plywood
CAF12	Angle brace on frame "B"	2	Britannia castings
CAF13	Fairleads/angle brace on frame "D"	1	Britannia casting
CAF15	Front machine gun support	1	Britannia casting
CAF16	Rear machine gun support	1	Britannia casting
GS4-7	Tail skid socket	1	.219" x .121" brass eyelet
WP3625	Longerons, vertical & horizontal fuselage formers, CAF22, seat rails & cross pieces	3/32" x 3/32" basswood strips	
WP3618	Fairing stringers	1/16" x 1/16" basswood strips	
WP161K	Bungee retainer	3/64" brass rod	
Misc. scrap wood building board and jig parts supplied by modeler			

vertical of frame "E" make sure that the fuel tank (CAF18) will fit snugly between the rails. Referring to Plan 02.5, cut and attach atop the seat rails the two fuel tank supports (just behind frame "D" and 5/8" behind that) and the two seat supports (between frames "C" and "D"). These extend to the outside edges of the seat rails, not the full width of the fuselage.

Locate the rear machine gun mount (CAF16) atop the longerons at frame position "B," then use a machine gun to position the front mount (CAF15), and

glue CAF15 in place. Leaving off the rear mount at this stage will make it easier to insert the ammunition boxes/chutes later.

To create the bungee retainer, refer to Plan 02.1 & 02.2 and drill a 3/64" hole through the longerons just forward of the doubled vertical formers at the fuselage tail and insert a length of 3/64" brass rod so that the ends are flush with the longerons.

Referring to Plan 02.5, glue a brass eyelet (GS4-7) into the joint at the end of the tail to make the tail skid socket.

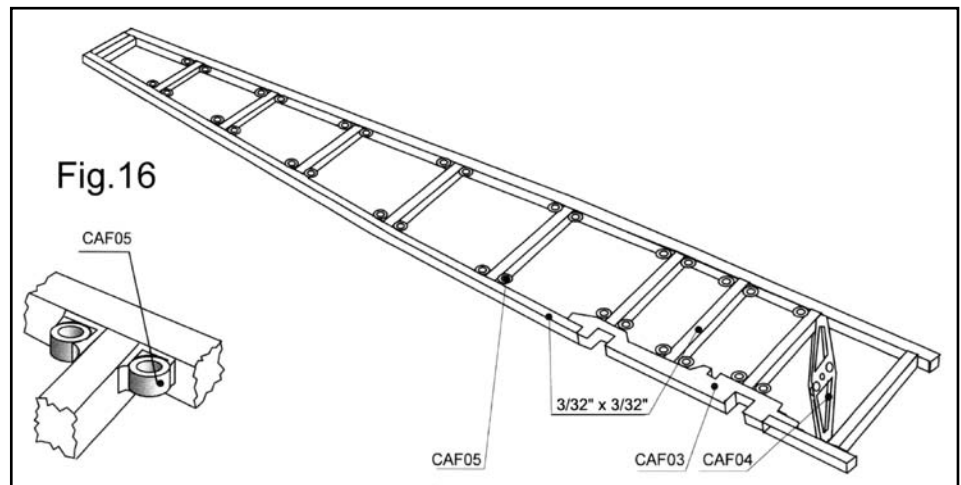

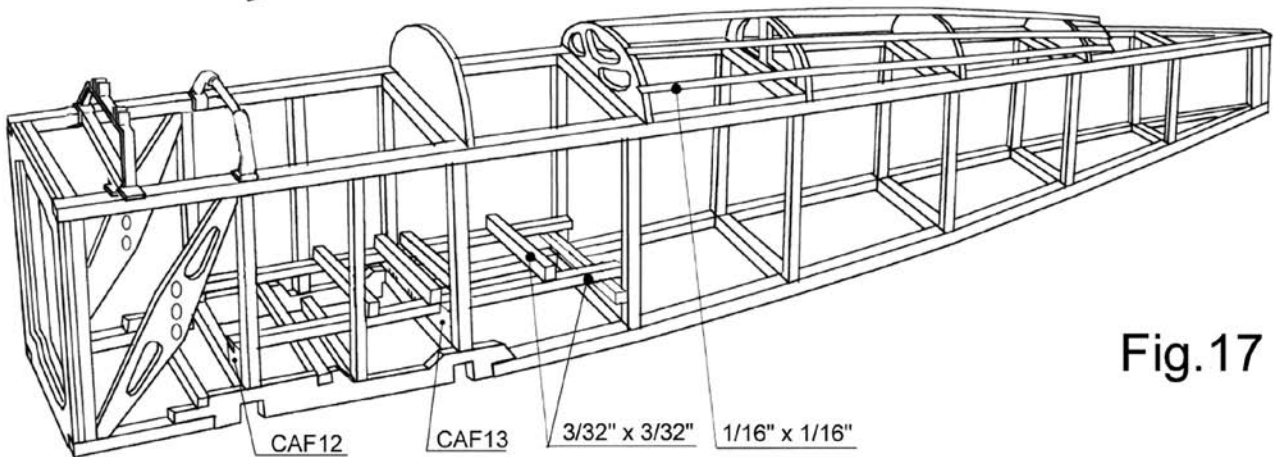
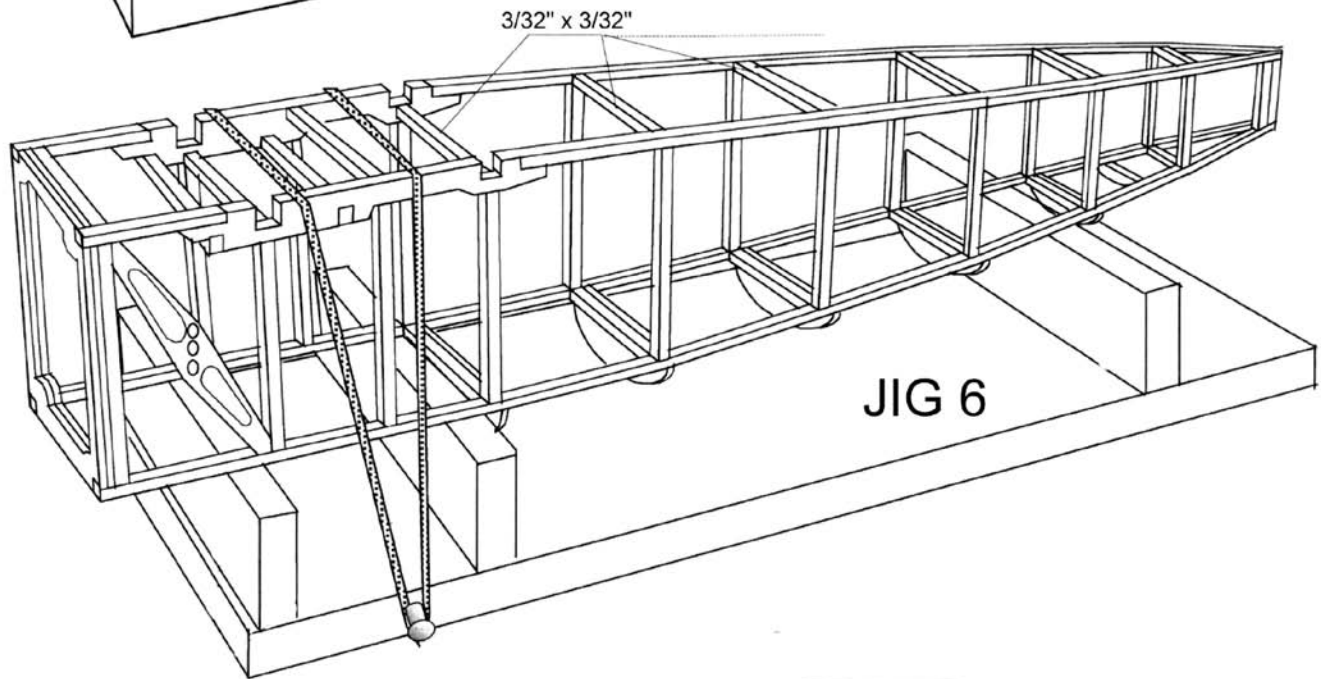
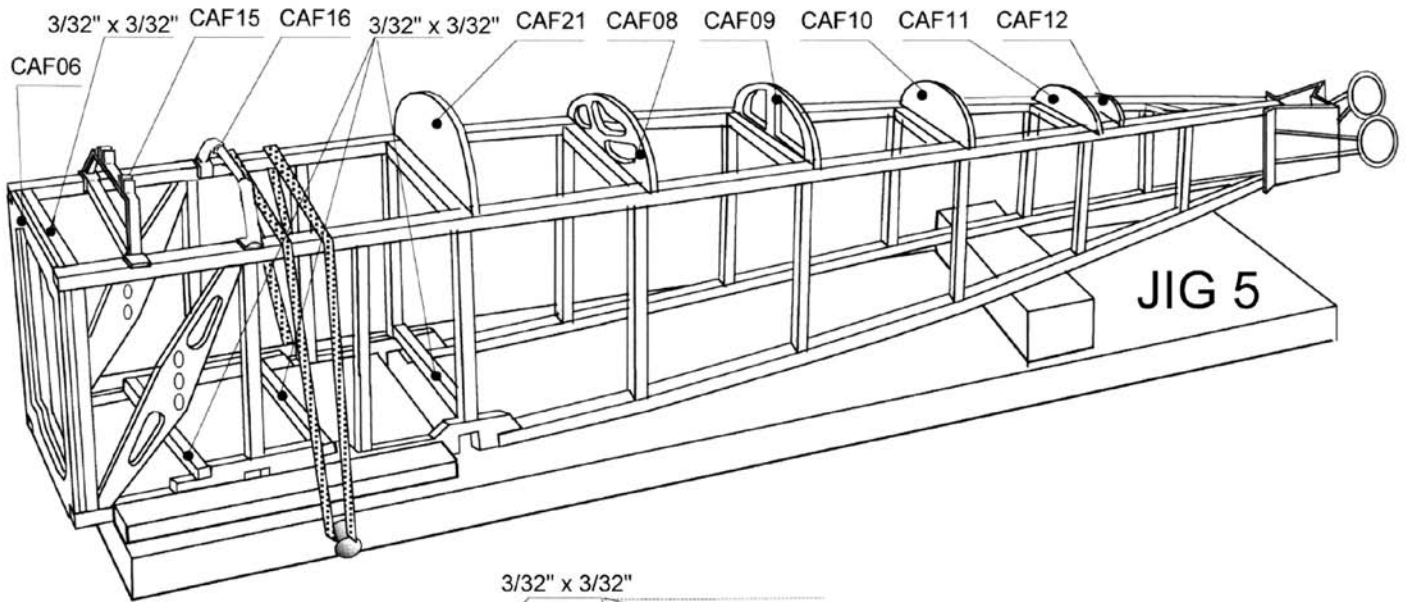

Fig.18

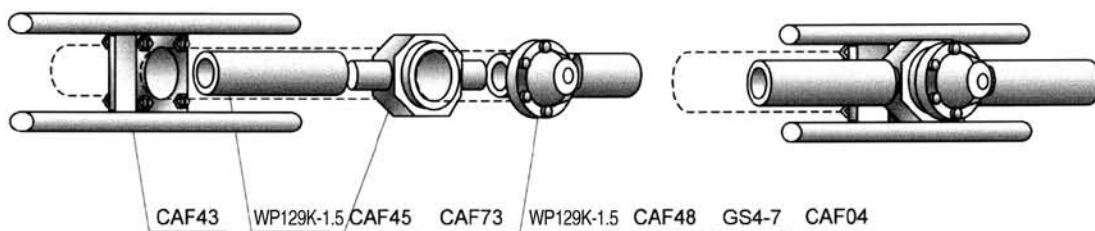
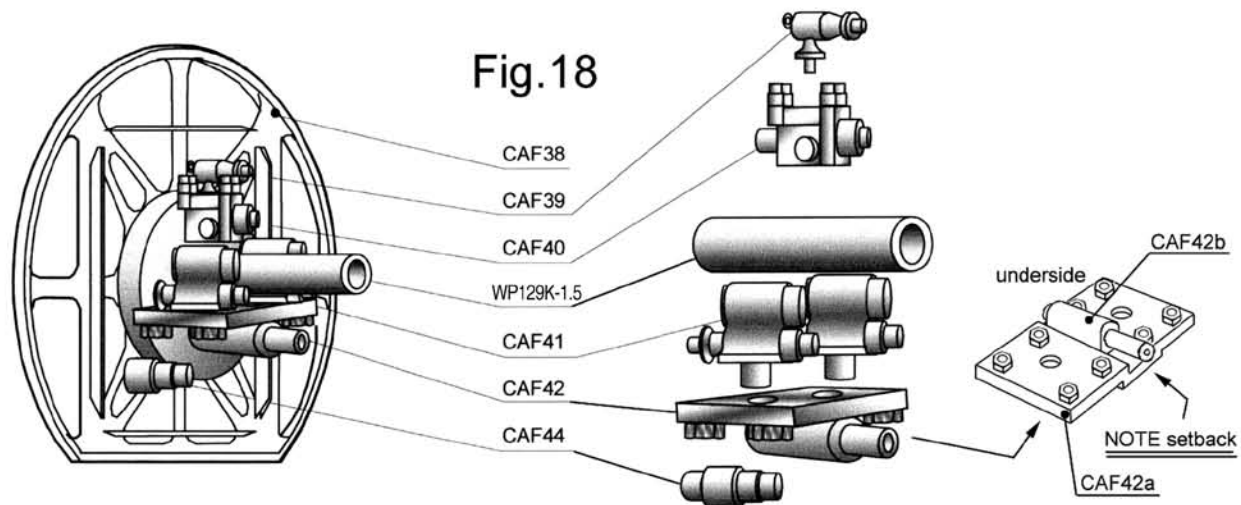
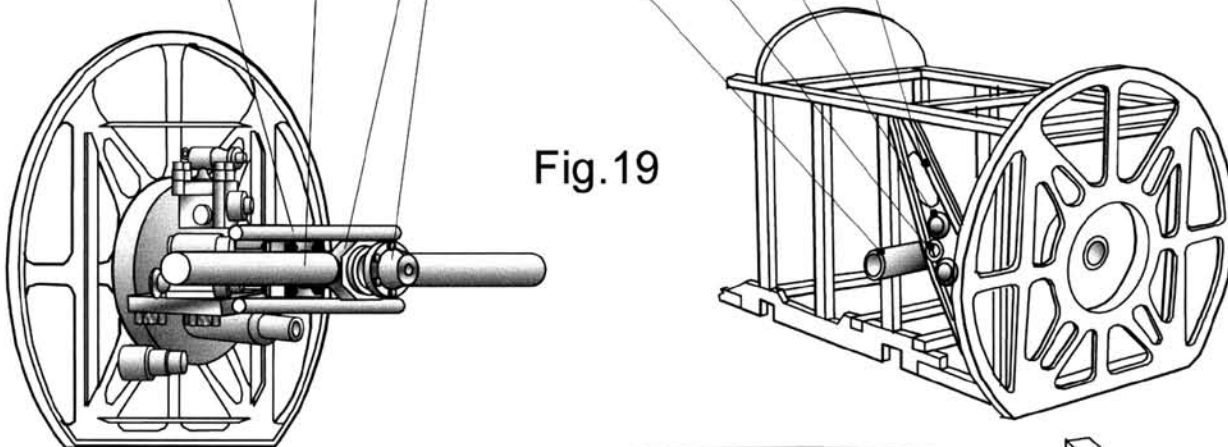
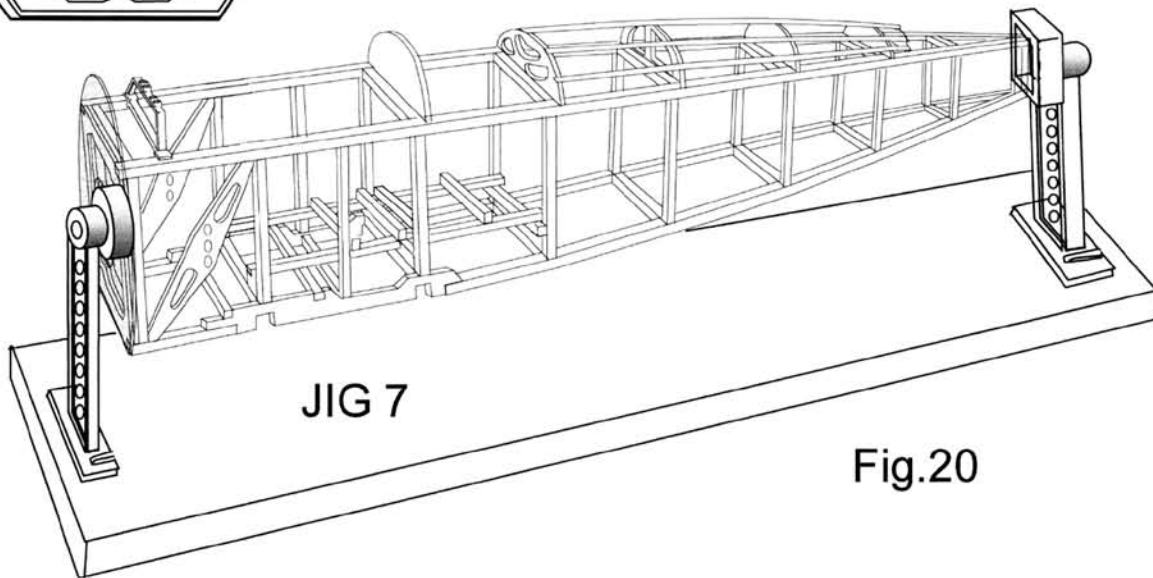

Fig.19



JIG 7

Fig.20



## STAGE 5: BUILDING THE ENGINE MOUNT AND PLUMBING

### Preparation:

Cut two 1" lengths of WP129K-1.5 to make the air intake tubes, then file a 106° angle to one end of each tube. When installed, the angled end faces out and tapers toward the front of the airframe like an air scoop. Cut a 1 1/2" length of WP129K-1.5 to make the engine mount tube.

Brass eyelets tend to be rolled in slightly at the non-flanged end. Use a needle file to straighten this out so the eyelets will slide easily over the ends of the rear support (CAF43). Referring to the plumbing schematic Fig.25, drill #69 shallow holes where indicated in parts CAF39, 40, 41, 42b and 45. Part CAF39 gets two holes, one in the end and one where the little cast tail is. Cut off the tail first. Finally, dry fit the engine mount (CAF38) to the front of the airframe. Sand and trim as needed to get a snug fit.

### Assembly:

Glue together the parts as shown in Fig.18 with the exception of the engine mount tube which should be left loose at this stage. Glue this subassembly to the airframe at former "A." Note the placement of part CAF42b in the channel on CAF42a.

Remove the brass tube and glue on the end cap (CAF73). Slide this assembly through the carburetor (CAF45), the rear support (CAF43) and then the center hole in the

### Parts List For Stage 5

CAF38	Engine Mount	1	Britannia casting
CAF39	Oil pump	1	Britannia casting
CAF40	Air pump	1	Britannia casting
CAF41	Magnetos	2	Britannia castings
CAF42a&b	Magneto support	1	each Britannia casting
CAF43	Rear support	1	Britannia casting
CAF44	Manual starter	1	Britannia casting
CAF45	Carburetor	1	Britannia casting
WP129K-1.5	Air intakes	2	3/16" x 1" brass tube
WP2841	Rear support connectors	4	.219" x .121" brass eyelets
CAF48	Rigging attachments	2	Britannia castings
WP129K-1.5	Engine mount tube	1	3/16" x 1 1/2" brass tube
CAF73	Engine tube end cap	1	Britannia casting

engine mount. Line up the four arms of the rear support with the two pairs of large holes in the diagonal mounts (CAF04), then slide the brass eyelets (GS4-7) through the holes to secure the support arms. Glue the eyelets to the arms being careful not to get any glue on the brass engine mount tube. Slip the air intakes over the carburetor studs, then slide the carburetor and the tube so that the intake tubes are straight out to the sides, just clearing the rear of the diagonal mounts. The hole you drilled in the carburetor casting should face straight up. Slide the mounting tube forward so the

end cap touches the carburetor and glue everything in place. Finally, glue the rigging attachments (CAF48) into the small holes on the diagonal mounts so that the rings are vertical.

### Firewall Option:

Although the kit does not include the firewall, it is a simple matter to make one from thin sheet aluminum, such as that of a flattened soda can. Either trace around CAF38 or use a compass to layout a 2 11/16" disc. Cut off the bottom to match CAF38 and cut a 3/4" hole in the center. Glue this to the front of CAF38.

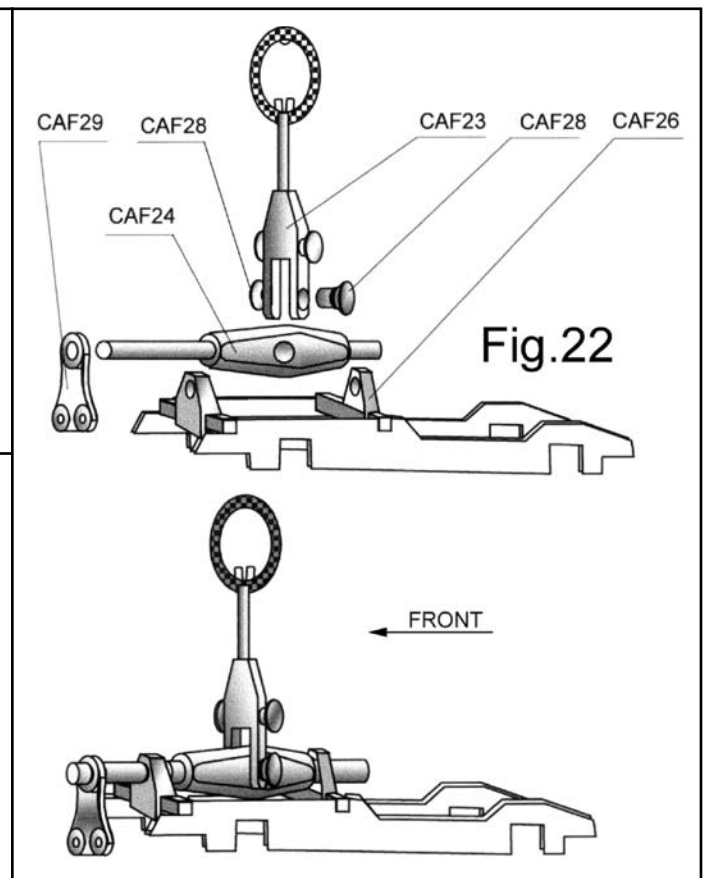
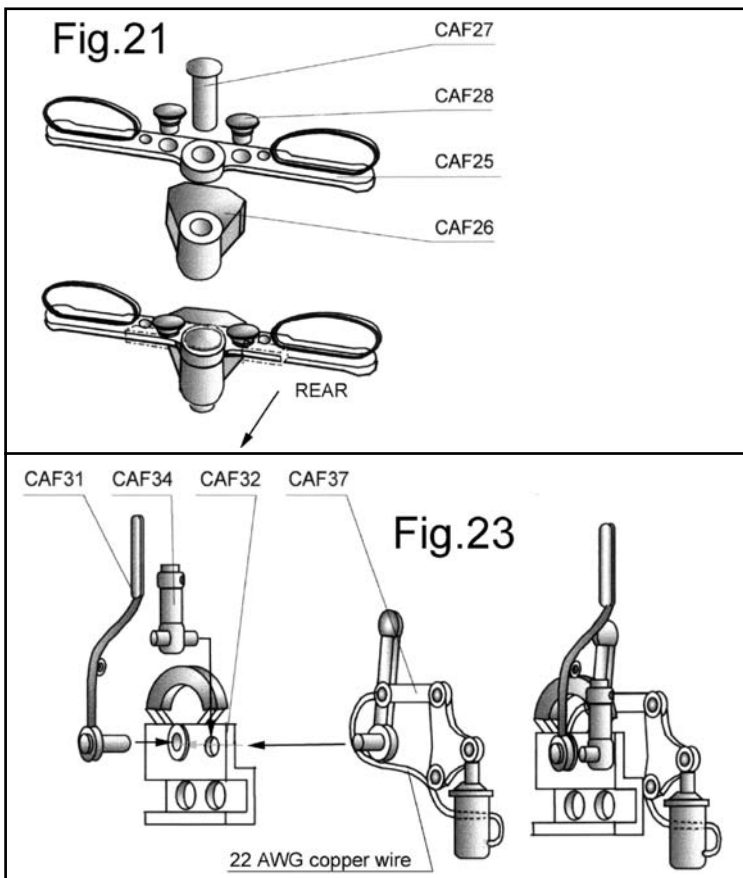



## STAGE 6: BUILDING THE COCKPIT AND CONTROLS

### Parts List For Stage 6

CAF16	Rear machine gun support	1	Britannia casting	CAF53	Pulsometer	1	Britannia casting
CAF17a&b	Oil tank	2	Britannia castings	CAF54	Magneto switches	2	Britannia castings
CAF18	Main fuel tank	2	Britannia castings	CAF56	Clock	1	Britannia casting
CAF18a	Main fuel tank filler	1	Britannia casting	CAF57	Air pressure gauge	1	Britannia casting
CAF19a&b	Auxiliary fuel tank	2	Britannia castings	CAF60a	Vickers machine gun	2	Britannia castings
CAF23	Control stick	1	Britannia casting	CAF60b	Gun charging lever	2	Britannia castings
CAF24	Trunion	1	Britannia casting	CAF61	Gun sight	1	Britannia casting
CAF25	Rudder bar	1	Britannia casting	CAF62a&b	Ammunition boxes/chutes	2	Britannia castings
CAF26	Supports	3	Britannia castings	CAF64	Tail skid	1	Britannia casting
CAF27	Rudder bar pin	1	Britannia casting	JIG 7a	Uprights	2	Britannia castings
CAF28	Pulleys	4	Britannia castings	JIG 7b	Tail holder	1	Britannia casting
CAF29	Aileron crank	1	Britannia casting	JIG 7c	Engine mount holder	1	Britannia casting
CAF30	Filler caps	2	Britannia castings	WP9912	#8-32 Jig 7 wing nut	1	Steel
CAF31	Throttle handle	1	Britannia casting	W042	Turnbuckles	32	Britannia castings
CAF32	Throttle quadrant	1	Britannia casting	GR9-15	Crankshaft	1	5/32" x 2 5/8" brass rod
CAF33	Fuel filter	1	Britannia casting	CAF49	Instrument panel	1	Laser-cut plywood
CAF34	Fuel tank selector	1	Britannia casting	SEC40223	Cockpit piping	22	AWG copper wire
CAF35	Hand pump	1	Britannia casting	WP29162	Instrument faces	1	Gloss paper – set of 5
CAF36a&b	Seat	2	Britannia castings	WP0976	Tank straps	1/4"	Copper tape
CAF37	Fuel mixture control	1	Britannia casting	WP1227	"Bungee cord"		Gray nylon twine
CAF50	Compass/inclinometer	1	Britannia casting	WP1205	Bracing wire		Metal-gray thread
CAF51	Instruments	3	Britannia castings				

### Subassemblies:

Referring to Fig.20, attach the fuselage to Jig 7 and your construction board. The flanged washer (Jig 7c) fits into the front center of the engine mount and is attached to one of the jig uprights simply by sliding the crankshaft (GR9-15) through the upright, then the washer and into the brass engine mounting tube. The fuselage tail fits into Jig 7b and is then secured to the second upright with the provided #8-32 wing nut. Be careful not to over tighten the wing nut or you risk stripping the threads from the cast part. Use the slots in the uprights' bases to screw them to your construction board. After this is assembled, loosening and tightening the wing nut will allow you to rotate and secure the fuselage while you work on the cockpit.

**Fuel and oil tanks and ammunition boxes/chutes:** Assemble the oil and fuel tanks and attach their fillers. Oil tank (CAF17a&b) and auxiliary fuel tank (CAF19a&b) are straightforward assemblies, as is inserting their fillers (CAF30). The main fuel tank (CAF18) requires a bit more work. The provided two castings are identical and must be joined so that the paired slots form paired holes at opposite ends. If you plan not to paint the cast parts, it is suggested that you solder these two parts together. Note the hollows at opposite ends. Drill out one of these for the filler pipe (CAF18a) and putty or solder the other to eliminate it. Also fill the paired

hole that is closest to the filler pipe. The completed fuel tank will have the filler pipe and one hole at the top and two holes at the bottom. Glue together parts CAF62a&b to make the ammunition boxes/chutes.

**Rudder bar:** Assemble the rudder bar according to Fig.21. Either peen the end of the pivot pin (CAF27) after inserting it through CAF25 and CAF26 or glue it to CAF26, being careful not to get any glue on CAF25, the rudder bar itself.

**Control stick:** Assemble the control stick to the trunion with two pulleys (CAF28) according to Fig.22. Pinned by parts CAF28, the stick should move easily on the trunion. Note that the gun triggers on the control stick should be to the short end of the trunion. DO NOT attach the supports (CAF26) and aileron crank (CAF29) at this stage.

**Throttle:** Assemble the throttle according to Fig.23. Complete this plumbing with 1 1/4" of provided copper wire bent and inserted into shallow #69 holes drilled into opposite ends of the fuel mixture control (CAF37). Refer to Fig.25 to locate points to drill five #69 holes for the remainder of the plumbing (copper wire), most of which will be attached later. The exception is the short piece, marked with an arrow, that should be attached now.

**Hand pump and tank selector:** Referring to Fig.25, drill #69 holes, where indicated,

in the hand pump (CAF35) and the fuel tank selector (CAF34).

**Seat:** Bend the seat back (CAF30a) so it fits into the groove on the seat bottom (CAF30b). Paint the seat back tan, to look like wicker, then glue the two parts together.

**Machine guns:** Attach the gun charging levers (CAF60b) to the holes on the right sides of the Vickers machine guns (CAF60a). DO NOT attach the gun sight (CAF61) until after the guns are mounted, at a later stage.

**Instrument panel:** Begin by painting black, if desired, parts CAF50, 51 and 57. The upper dome of the pulsometer (CAF53) can be left unpainted to represent the original which was glass, and the lower part can be painted brass. The toggles on the magneto switches (CAF54) should be painted brass while the base of the leading switch should be white and of the trailing switch black. Laser-cut part CAF49, the panel itself, may be stained mahogany. Cut out and glue in place the paper gauge faces according to Fig.24 and then assemble all of the parts according to the same drawing. Although it will be a tight fit behind the instrument panel once it is installed, it is worth the effort to enhance your model with the piping depicted in Fig.25\*.

Therefore, drill #69 holes in the backs of the tachometer and the air speed indicator, in the pin of the pulsometer and in both the pin and the bottom of the air pressure gauge.

\* Note that Fig.F10 is a schematic that does not purport to show the actual piping runs. The runs should be kept as short as possible while considering neatness and clearance – especially where the line from the hand pump passes the rudder bar.

**Installation:**

Refer to Plan 02.6 to install the control stick. First slide one support CAF26 onto the long trunion pin so the slot faces away from the stick, then glue the aileron crank (CAF29) to the same pin so it hangs down in line with the stick. Center and glue the support to the horizontal member at Frame “B”. Finally, slide the second support onto the short trunion pin and glue it to the next horizontal frame member. The slots in both supports face to the front of the fuselage.

Referring to Plan 02.7, glue the throttle assembly to the left seat rail, sliding it as far forward as you can.

Glue the main fuel tank to its supports, according to Plan 02.6, angling it so the filler pipe cap lines up with an imaginary line from the aft fairing to the top of CAF21 at Fame “D.” Cut a 4 1/2" length of copper tape, then cut it into two 1/8" wide strips. Use these to make the fuel tank straps, wrapping them around both tank supports as well as the main fuel tank. Be careful not to cover any of the holes in the tank. Then glue the auxiliary fuel tank atop

the longerons, behind CAF21.

Use the provided copper wire to pipe both fuel tanks to the fuel tank selector (CAF34) and from the selector to the throttle assembly. It is important to determine the connection between the selector and the throttle before attaching the selector to the chair rail in order to achieve the closest possible fit of the two parts. Refer to Plan 02 and Fig.25. Attach the hand pump (CAF35) to the right side seat rail and run the piping per Fig.25. Finish up by attaching the oil tank to the top longerons and the tank to the oil pump by means of a short length of copper wire.

Dry fit the ammunition boxes/chutes behind the front machine gun support, with the attachment bar toward the front. Dry fit the rear machine gun support and lay a machine gun across the two supports to check the fit of the chute tops to the underside of the machine gun. If necessary, file down the chute tops so the machine gun lies level in both its supports and the chute tops just touch the underside of the machine guns. Glue the ammunition boxes/chutes and the rear machine gun support in place. Refer to Plan 02.

Slip the instrument panel between the ammunition boxes/chutes and the rear machine gun support close to the rear gun support. Now is the time to run the piping to the instruments, if desired.

Refer to Fig.25.

Insert the tail skid (CAF64) into the socket at the tail and, using the gray twine “bungee cord” (WP1227) tie off the hooked end to the bungee retainer. This will also serve to keep the tail skid from falling out of its socket. The skid should be free to turn because it will be cabled to the rudder bar at a later stage.

Referring to Plan 02.5, use 16 turnbuckles per side and metal-gray thread (WP1205) to string the fuselage cross bracing. Use the same method you chose for the wings. After bracing the sides, use the same lower parts CAF05 to cross brace the bottom from Frame “E” to Frame “I.” No turnbuckles are used for this.

Attach the machine guns, then attach the gun sight across the front end of the guns. Some Camels had the single gun sight mounted on the right machine gun only instead of between the two. If you prefer this alternative, simply trim the bar on CAF61 to the central pin and glue the sight on that location.

Glue two 3/4" long pieces of 3/32" x 3/32" wood under the seat, running front to back, then glue the seat assembly to the pair of supports within the cockpit. See Plan 02.6.

Remove the fuselage from Jig 7.

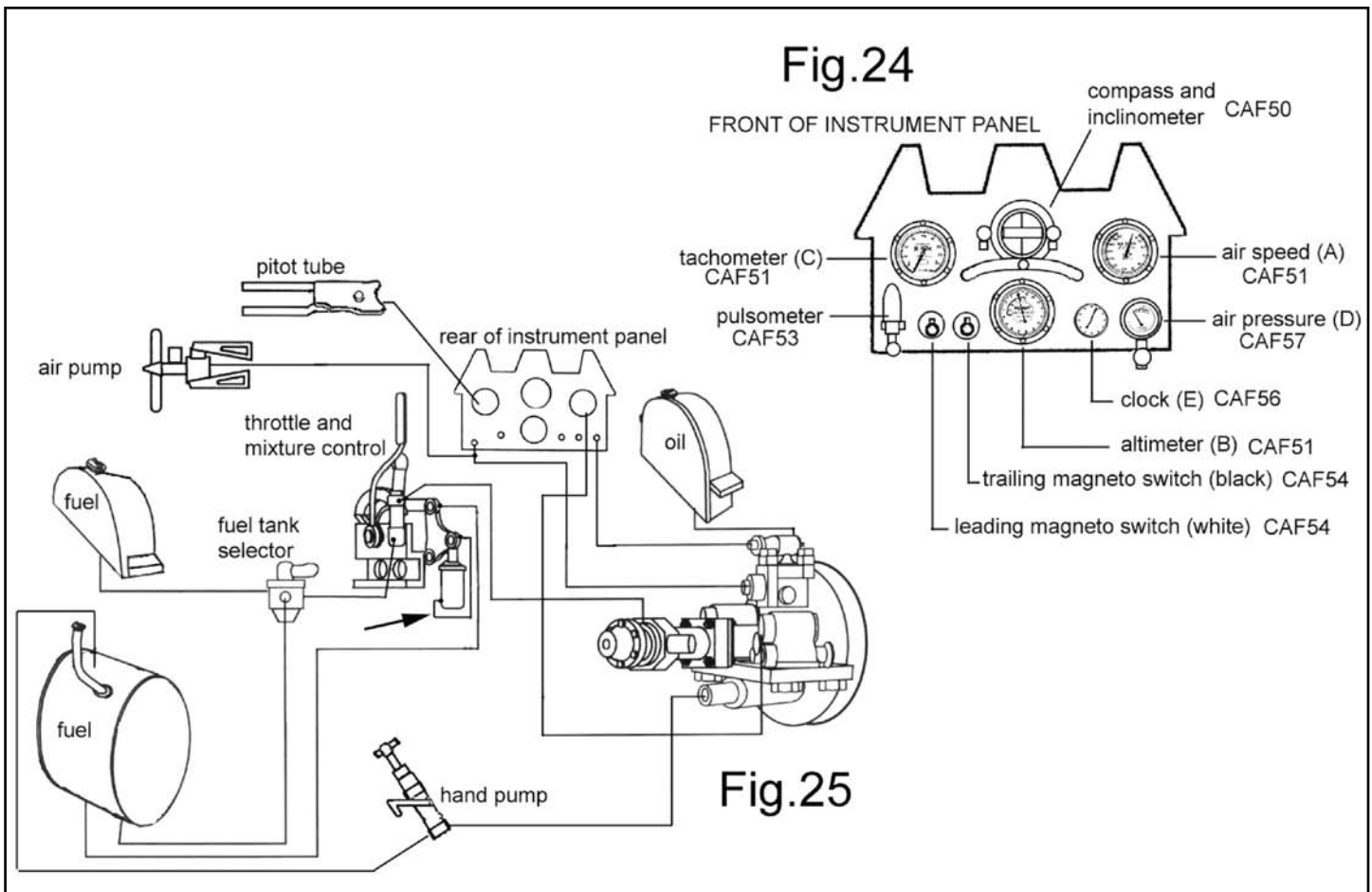

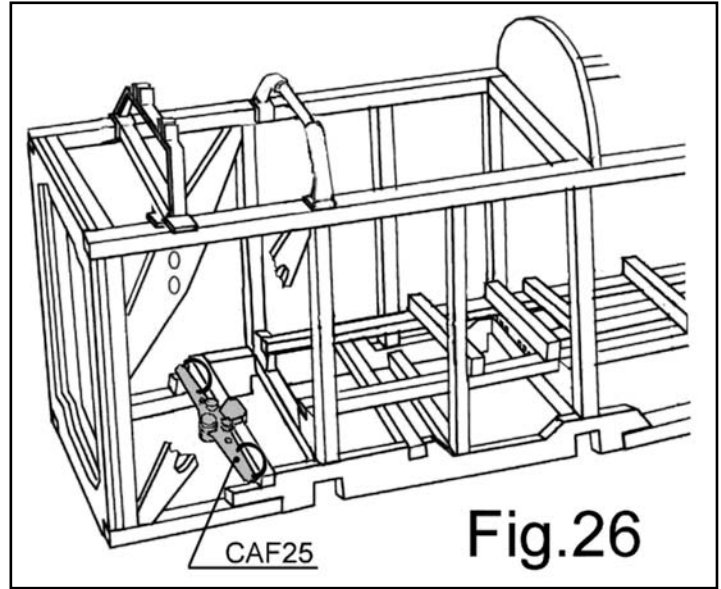
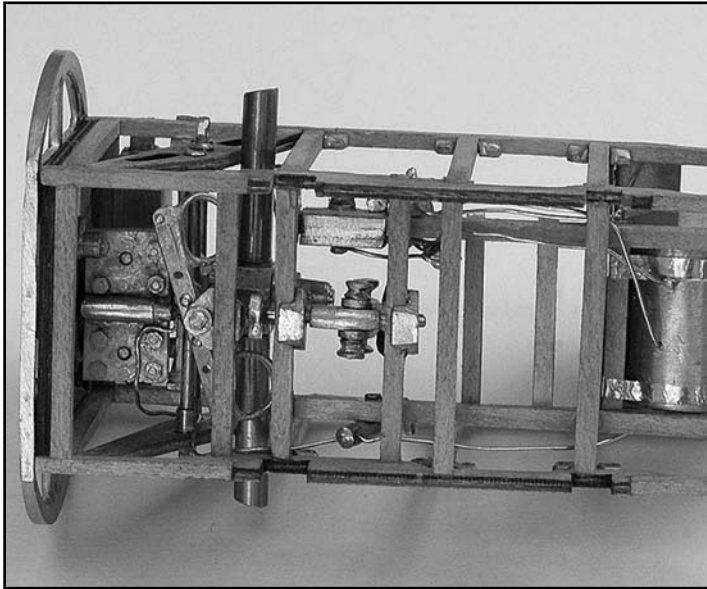

## STAGE 7: EPENNAGE INSTALLATION AND CABLING

### Empennage assembly:

Center the horizontal stabilizer on the fuselage top by positioning the spar at Frame "I." It is recommended that you strengthen the joint by drilling through the spar and longerons, into the vertical frame members, to insert two small brads as you glue this in place. (See Plan 04.5 and Fig.27)

Glue the vertical stabilizer pins into the holes in the horizontal stabilizer. Finish this up by rigging the bracing wires from metal-gray thread (Fig.27). Use a turnbuckle on each side in the rear where the thread passes through the top of the horizontal stabilizer and the bottom of the vertical stabilizer. The forward of the two bracing wires has turnbuckles where the thread passes through the top of the compression bar on the horizontal stabilizer and where it is tied off at the nearest CAF05 on either side of the bottom of the fuselage.

### Control cabling:

Prepare by cutting the flanges from four small brass eyelets (GS2-3) and filing the ends smooth.

Stand the aircraft on its nose, using a block of wood to clear the attached machine guns. Brace the rudder bar and rudder into their neutral position. Refer to figures 28-30. To use the least amount of thread, run the end through the tie-off ring on the rudder, then the right hand rudder horn, through the fuselage and the far right fairlead on CAF13 ("e" on Fig.29), and through a prepared small eyelet. Continue the run through the right hand hole on the rudder bar, back through the eyelet, through fairlead "f" on CAF13, and back through the fuselage to the right hand horn on the tail skid. Tie it off, then pull it snug to the rudder bar, slide the eyelet against the rudder bar and glue it and the thread.

### Parts List For Stage 5

W042	Turnbuckles	8	Britannia castings
WP1205	Rigging and control cables		Metal-gray thread
WP2839	Cable crimps	4	Small brass eyelets
<b>not supplied</b>	2 Small brads (optional)		

Snug up the run back to the rudder horn and tie-off ring, glue into place and trim. Repeat for the left side. When the rudder and rudder bar are released, they should move normally.

Brace the stick and the horizontal stabilizer to their neutral position. Cut off about 2.5' of metal-gray thread, and tie one end to the top right hand pulley on the control stick (Fig.28). Run the thread forward, around the right hand rudder bar pulley, going from inside to outside, under the lower stick pulley, and through the outermost fairlead "a." Continue the run back through

the fuselage, emerging above the upper longeron between Frames "G" and "H," to the upper right side elevator horn, through the tie-off ring then the lower elevator horn, and back into the fuselage between Frames "G" and "H." After passing this through "b" on Fig.28 run the end through a prepared small brass eyelet and back to create a loop which goes over the upper right stick pulley where you started. Make everything snug and glue in place. Repeat for the left side. When the stick and elevator are release, moving the stick forward should pull the elevator downward; back, upward.



# Fig.27

small brad reinforcement  
 ribs removed for clarity  
 turnbuckle must clear rib

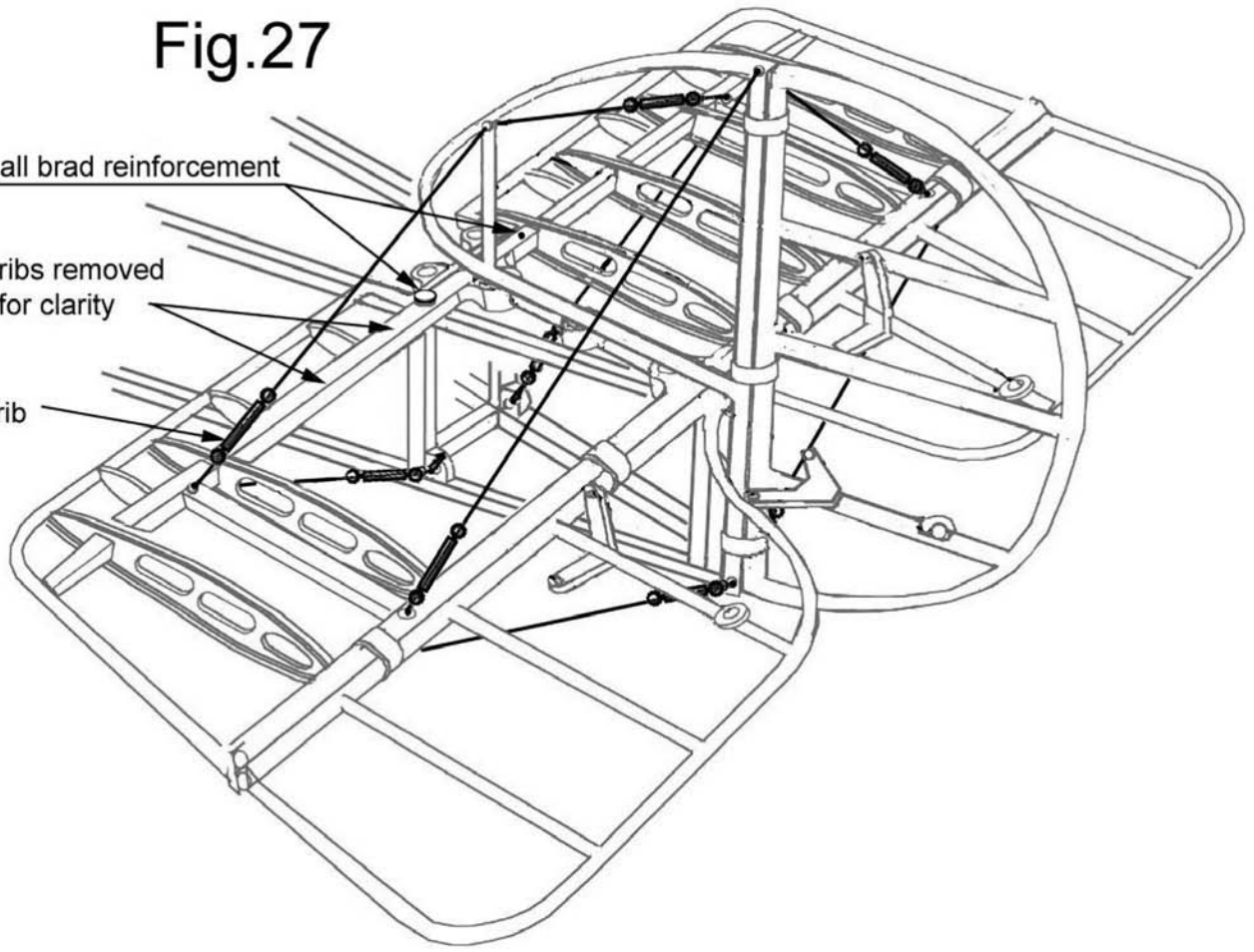

## STAGE 8: ATTACHING THE LOWER WING AND UNDERCARRIAGE

Tie off the ailerons to avoid damaging them and glue the lower wing into the slots under the fuselage. There should be a space forward of the front spar through which the aileron cable will pass.

Referring to Fig.33, orient the struts (CAF70) left and right (they slant inward to the fuselage, and drill a #69 hole through the lower end of each front strut. Glue an eyebolt in each hole, ring to the inside, and file off any of the shaft that protrudes out the other side. Referring to Fig.31, drill three #69 holes under the fuselage and glue in eyebolts for the undercarriage bracing. Drill two additional holes through CAF03 and glue in eyebolts that will later serve as aileron cable guides. Trim the eyebolt shafts so they do not protrude outside the fuselage.

Using sheet aluminum from a soda or beer can, cut out a piece 3/4" x 1 1/8". Steel wool off the paint and varnish and drill a #69 hole dead center. Line this hole up with the one in the center of the Axle (CAF69). Pin it in place with an eyebolt so the short edges touch the Axle hinges, then bend down the long edges to wrap over the outer Axle supports. Now glue it and the eyebolt in place. See Fig.33.

### Parts List For Stage 8

CAF69	Axle	1 each	Britannia casting
CAF70 L/R	Landing gear struts	1 each	Britannia castings
W042	Turnbuckles	3	Britannia castings
WP1227	Bungee cord		Tan nylon cord
WP1205	Bracing wire		Metal-gray thread
WP0434B	Rigging eyes	8	Brass eyebolts
	Aileron fairleads	2	
<b>not supplied</b>	Axle cover	1	Soda can, aluminum

Slip the struts over the Axle and secure by wrapping about three turns of WP1227 around each end as in Fig.34. Temporarily secure the struts to the Axle with a rubber band. Fit this assembly to the fuselage so that the front strut tops attach at Frame "A" and the rear tops fit between the lower wing ribs and the fuselage to attach at Frame "C." Note the holes through the top parts of the front struts. Drill through these into Frame "A" and secure each with an eyebolt. Fig.35. Check the alignment, then glue into place. From underneath, make sure the Axle and struts fit tightly together, then glue them together.

Using a turnbuckle at each eyebolt on the undercarriage, use WP1205 to rig the

bracing wires. Wires run from the strut eyebolts back to the opposite side of the fuselage and from the Axle eyebolt straight up to the eyebolt in the center of the rudder bar support.

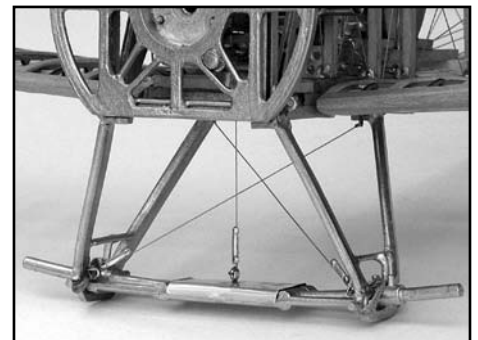

Fig.28

Elevator Cables

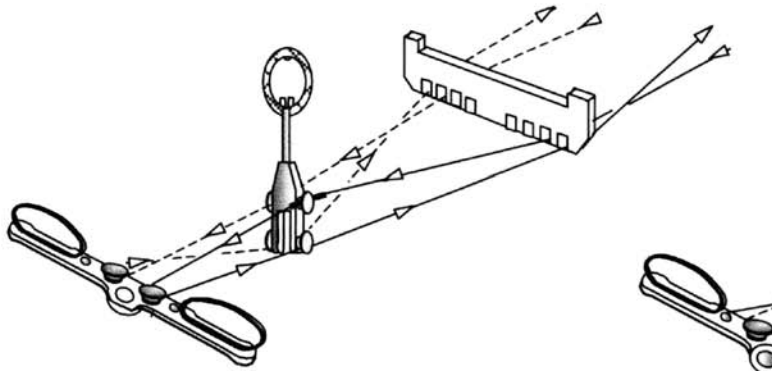
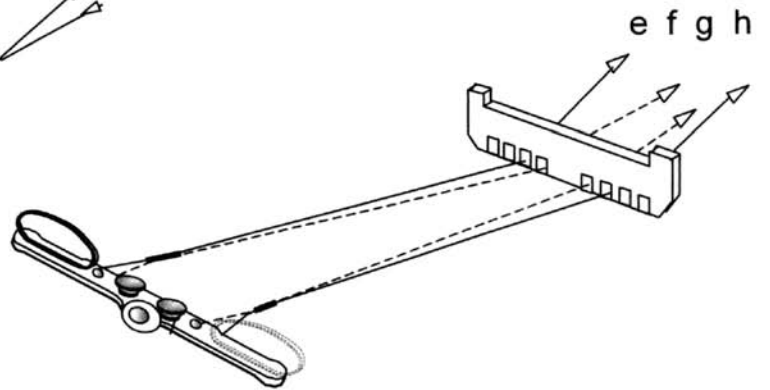

Fig.29

Rudder & Tail Skid Cables



RUDDER AND ELEVATOR CONTROL CABLES

Fig.30

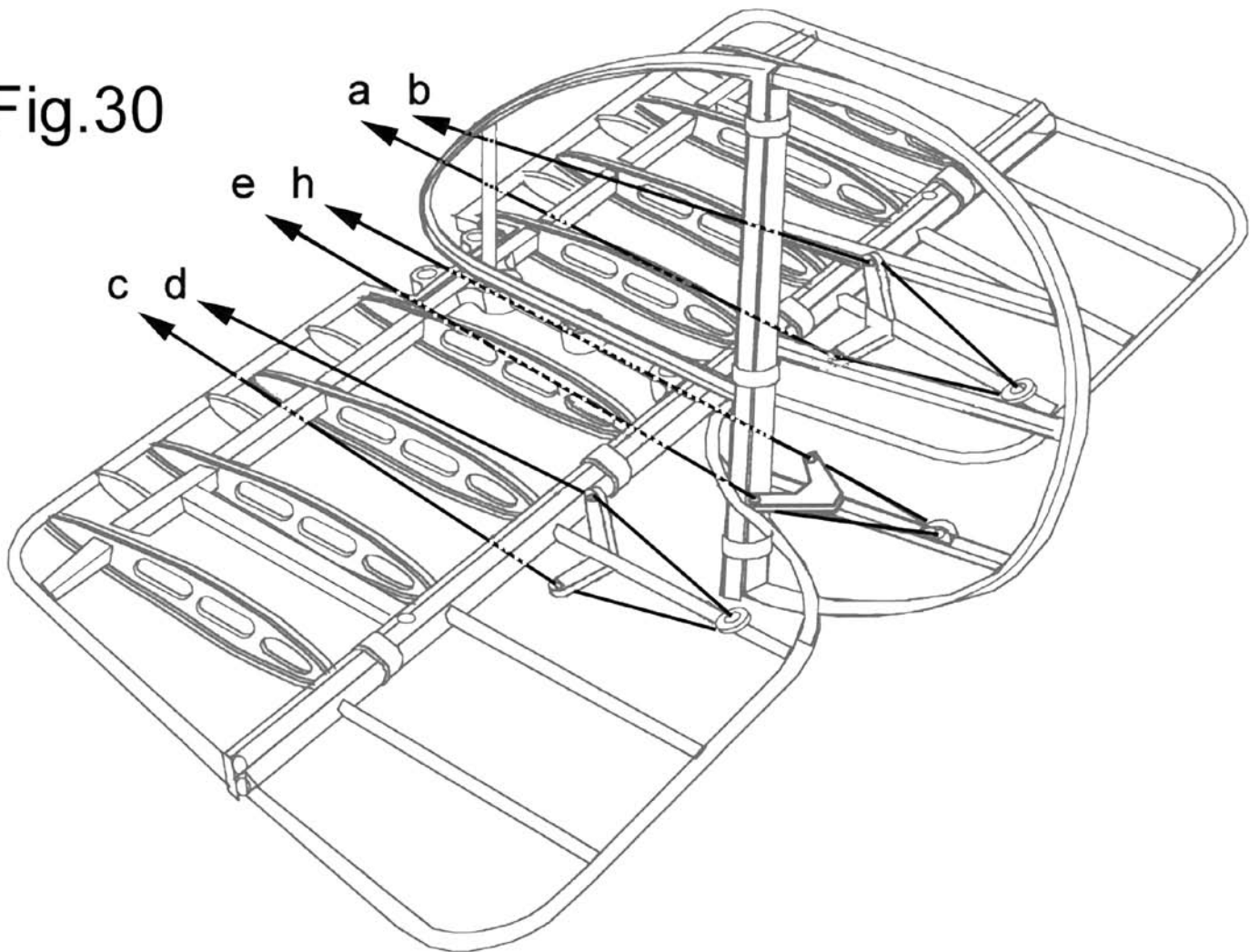

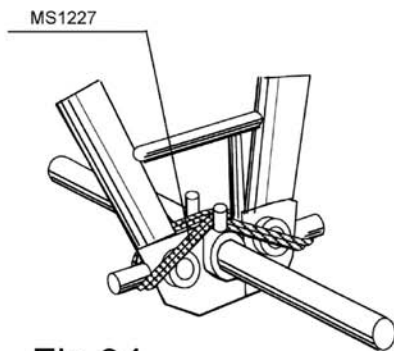
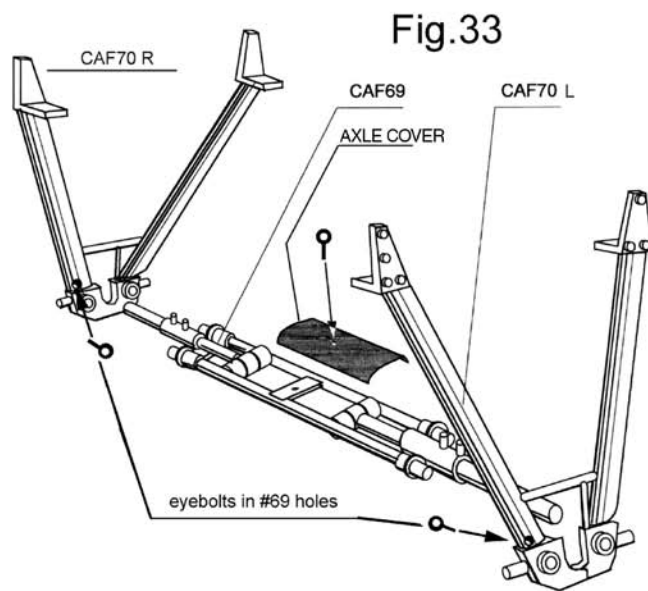
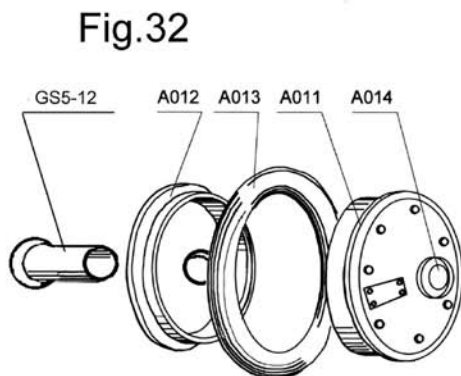
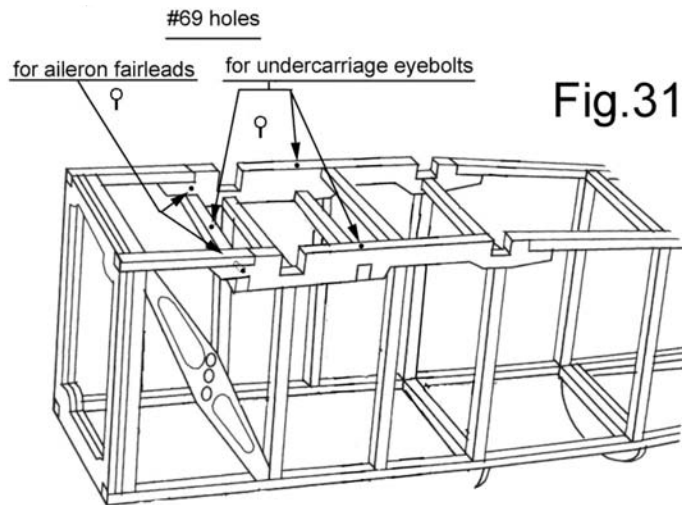
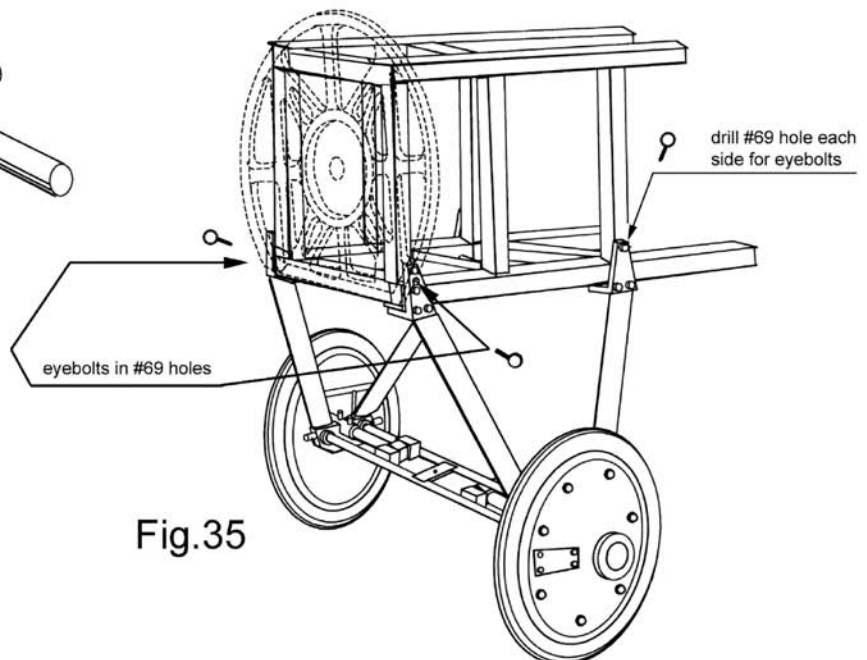

Fig.34



## STAGE 9: ATTACHING THE UPPER WING, CABLING AND BRACING

### Cabane struts and preparation:

The tops of the rear undercarriage brackets should protrude slightly above ribs CAW03 at Frame "C." Drill a #69 hole into the casting on each side and glue in an eyebolt you have trimmed so the ring sits as close as possible to the wing. Fig.35.

Note the stamped numbers on the insides of the lower brackets of the cabane struts. Numbers one and three attach to the left side; struts two and four attach to the right. See Plan 04. Referring to Fig.36, drill #69 holes where indicated on the cabane struts. Cut short and glue in eight of the remaining ten rigging eyes. The two exception are left long and are used to pin the lower ends of cabane struts #1 and #2 to Frame "A." Attach these struts first to the fuselage. Confirm the distance between the holes on compression bars CAW25, then attach the rear cabane struts (three and four) at Frame "C" so the paired spacing of the top holes matches that of the holes in CAW25.

### Upper wing:

Tie off the upper wing ailerons to avoid damaging them. Set the upper wing into place with the upper ends of the cabane struts inside the attachment brackets on the inner compression bars. Pin the wing in place using four false bolts (CAW41), inserted with the heads toward the centerline of the aircraft. Check the level of your work surface before checking that the wing is level. Chances are good that if the wing looks off it is because your table slopes. The holes through parts CAW40 and CAW25 are larger than the diameter of the false bolts to allow room for adjustment. When you are satisfied that the wing is level, glue the joints. Trim the bolts so they protrude slightly.

The interplane struts are made from four 2 25/32" lengths cut from the 3/32" x 1/4" wood strip. Cut a lengthwise slot into each end of the struts, that measures 1/32" wide by 1/16" deep, for the end fittings CAW42. Next, sand the struts to an oval cross section. Referring to Fig.37, glue the end fittings into the slots, making sure the sides with the cast nuts all face the same way, and slightly taper the struts from about 3/16" from the ends. If desired, stain the struts gold-mahogany and finish with varnish or shellac.

Refer to Plan 01. The interplane struts are positioned outboard of the fittings on compression bars CAW25, with the nuts on CAW42 facing out. Secure these with false bolts as you did with the cabane struts, and check the wing's alignment before gluing the false bolts in place. Trim the bolt ends so that they slightly protrude through the nuts.

### Parts List For Stage 9

CAW40	Cabane struts (4 numbered)	1 ea.	Britannia castings
CAW41	False bolts	12	Britannia castings
CAW42	End fittings for interplane struts	8	Britannia castings
CAF75	Pitot tube	1	Britannia casting
CAF76	Fuel pressure pump	1	Britannia casting
CAF77	Cabane bracing tensioner	1	Britannia casting
WP3629	Interplane struts	4	3/32 x 1/4 basswood
W042	Turnbuckles	10	Britannia castings
WP1205	Interplane bracing wire		Metal-gray thread
WP0434B	Rigging eyes	12	Brass eyebolts
WP40223SEC	Piping		22 AWG copper wire

### Fuel pressure pump & pitot tube:

If you are installing all of the plumbing, drill a #69 hole in the underside of the fuel pressure pump (CAF76). The two cylinders are on the top. Glue the pump to the outside center of the right front cabane strut so the little propeller is to the rear. Use a length of 22 AWG bare copper wire to run from the pump, down the strut, behind the instrument panel to the bottom fitting of the air pressure gauge. Try to make the run as neat and short as possible. The copper wire may be secured to the strut by a thin strip of copper tape.

Drill a #69 hole in the bottom of the pitot tube casting (CAF75) for the plumbing. Drill a shallow 1/16" hole in the outside of the right front interplane strut, about 7/8" down, and glue the matching stud on part CAF75 into this hole. Using 22 AWG bare copper wire, run the piping from the hole in the pitot tube casting down the strut, into the wing and through the space between the leading edge and the front spar to the fuselage, and through the slot in which the lower wing is attached. The piping then runs up behind the right air intake tube to the back of the air speed gauge on the instrument panel. This is a difficult connection to make with a single continuous run of wire. It is recommended that you join a short run down from the air speed gauge to the longer run through the wing at the slot in CAF03 where the lower wing joins the fuselage. A daub of glue covered with copper paint will look like a pipe joint, but will be invisible unless you display your model on a mirror. Be careful to leave room to run the aileron control cable through the same slot in CAF03.

### Struts bracing & aileron cabling:

Refer to Fig.38 and the Full-size Plans. Use turnbuckles (W042) at the lower end of each run, and Metal-gray thread (WP1205) to rig the cross bracing. Make sure the braces are snug, but do not over-tighten them.

Begin between the front cabane struts. Run the metal-gray thread through the tear-drop shaped tensioner (CAF77) and tie off the ends to the upper brass rigging eyes. Run a second length of thread through CAF77 and tie off the ends to the inner rigging eyes you used to pin the cabane struts to Frame "A." Next rig the front to back cabane bracing through the appropriate rigging eyes.

Bracing between the interplane struts is tied off at the waist on the strut end fittings. The front flying wires go from the rigging eyes in Frame "A" to the tops of the front interplane struts and are doubled. All the other braces are single strand. The rear flying wires go from the rigging eyes in the rear undercarriage brackets up to the tops of the rear interplane struts. There is a turnbuckle at each lower end. The landing wires run from the bottoms of the interplane struts to the top rigging eyes of the cabane struts, with a turnbuckle at each lower end. Finish up by tying the cross bracing between the interplane struts, again using a turnbuckle at each lower end.

Temporarily fix the ailerons and the control stick into their neutral position. Stand the model on its nose, using a block of wood to clear the machine guns, and, working from the bottom, install the aileron cables as a single continuous run from one hole in the aileron crank, through the eyebolt on the same side, back to the opposite gap in CAF03 and between the leading edge and front spar of the lower wing, around the pulley, to the lower horn and anchor, then up to the upper anchor and horn, around the pulley, between the leading edge and front spar of the upper wing, and similarly back down to the other hole on the aileron crank. Snug this up and tie it off at the aileron crank, and glue cable where it passes through the anchors. When everything is released, moving the control stick to one side should raise the ailerons on that side and lower the ones on the opposite side as in Fig.40.

Fig.36

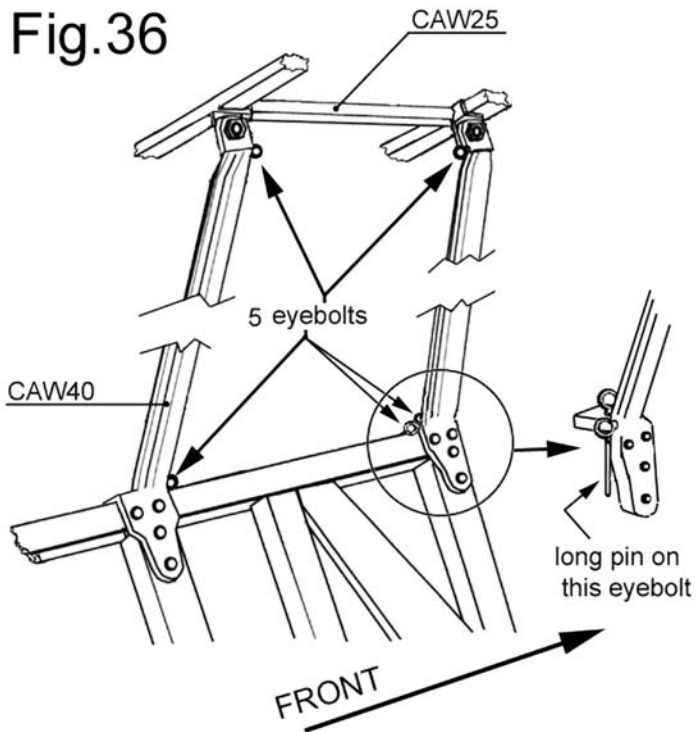

Fig.37

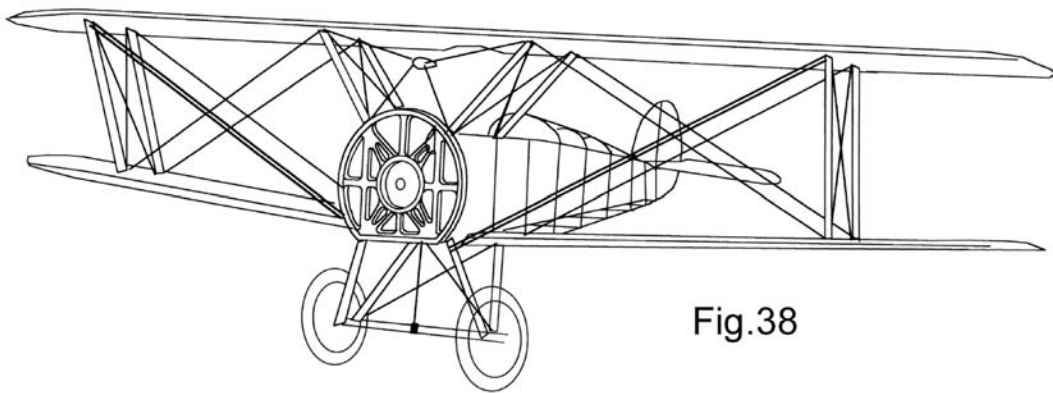
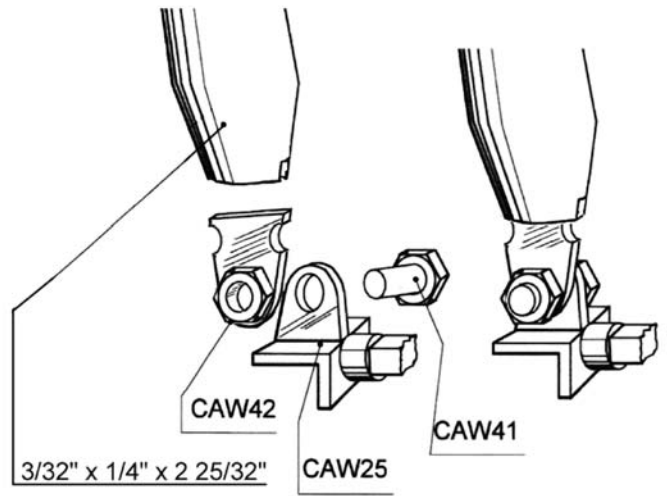
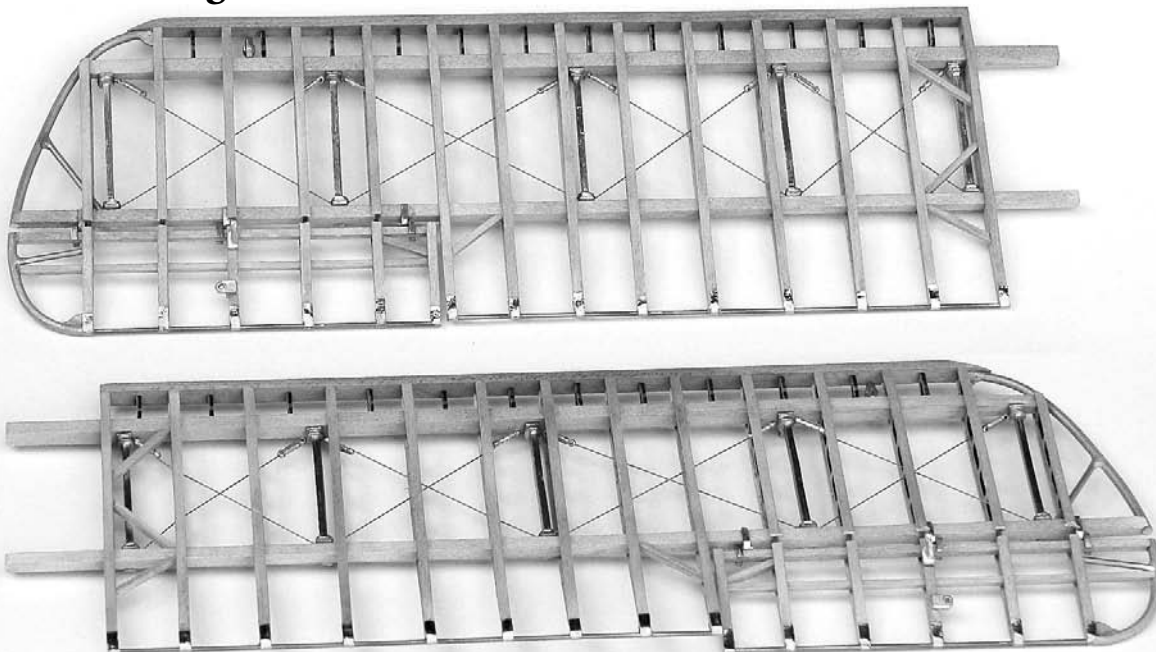

Fig.38

### Lower Wings





# Wing Tip

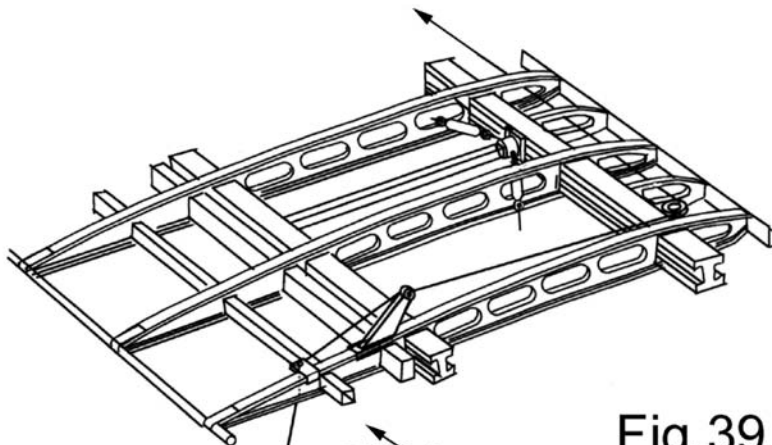
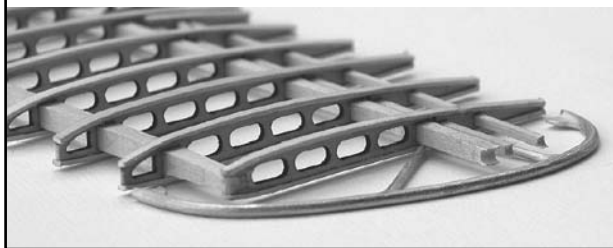

Fig.39

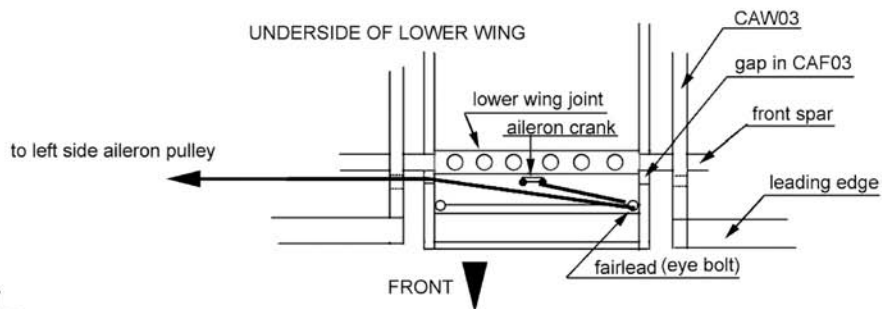
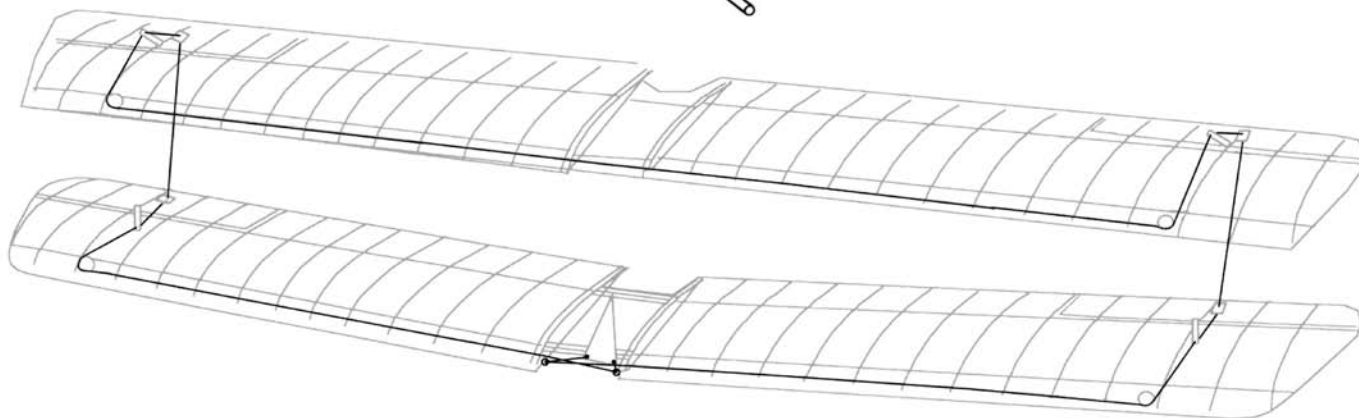
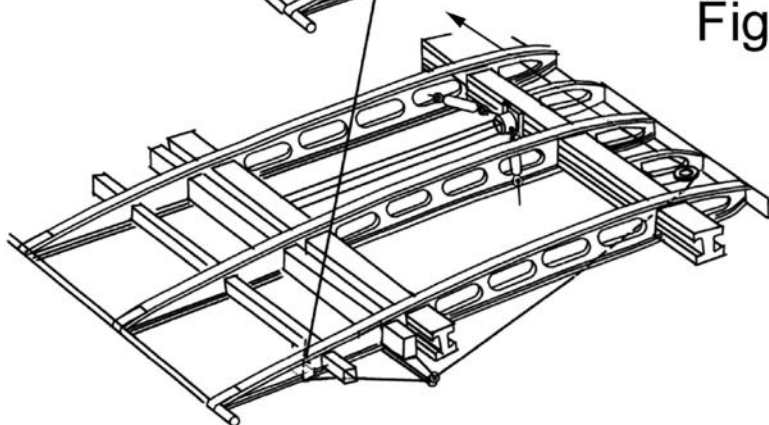
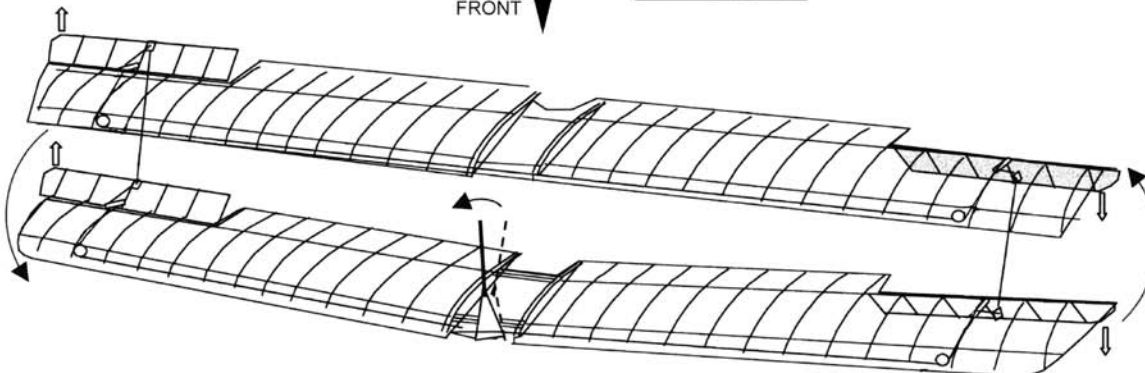

Fig.40  
(schematic)



## STAGE 10: FINISHING TOUCHES

### Cockpit coaming:

Form the cockpit coaming (CAF59) from the provided 14 AWG insulated copper wire. The overall shape is roughly the outline of a potato chip. Refer to various figures and photographs as a guide. The front end is rather squared as it bends up and then across the top of the back ends of the machine guns. Join the two ends of the coaming in the center of the straight run over the guns. With a little care, you can drill a dimple into one end of the bent wire and strip and file a little bump on the other end, so you can achieve a tight fit when gluing the ends together. Paint it leather brown. Drop the finished coaming into place between the rear cabane struts. The bottom should rest on the cabane brackets atop the longerons. Glue it in place.

### Wheels: (see Figure 32, page 22)

Glue together the wheels by sliding each inner wheel half over a brass Axle sleeve, followed by a tire and the outer wheel half. The sleeves will not reach all the way to the outside of the outer wheel halves. These "solid" wheels were actually fabric grass guards stretched over wire spoke

### Parts List For Stage 10

A011	Outer wheel halves	2	Britannia castings
A012	Inner wheel halves	2	Britannia castings
A013	Tires	2	Rubber O-rings
A014	Wheel hubs	2	Britannia castings
WP2842	Axle sleeves	2	Large brass eyelets
CAF59	Cockpit coaming		14 AWG insulated wire
GR9-15	Crankshaft	1	5/32" x 2 5/8" brass rod

wheels, therefore you might want to paint these a canvas color. Check the fit on the Axle and trim the Axle if necessary so the hubs will not quite touch the wheels after the hubs are glued in place. The wheels should turn freely. The wheels themselves are supposed to angle in at the top. They were only straight up and down when the plane was airborne.

prop to the brass engine tube. Check over the entire model to ensure all glue joints are tight. Carefully clean any previously unnoticed excess glue beads and touch up the varnish and paint if needed.

### Congratulations - your SOPWITH CAMEL is finished!

We at Model Airways and Model Expo hope you have enjoyed this project and look forward to flying with you on your next aircraft modeling project. As this is a delicate model, we suggested that you mount it on a suitable baseboard and cover it with a protective glass or acrylic display case.

### Engine and propeller:

Insert the crankshaft into the engine mounting tube, the slide the combined propeller and motor sub-assembly onto the crankshaft, allowing it to turn freely. Check the clearance between the propeller and the machine gun muzzles before glueing the

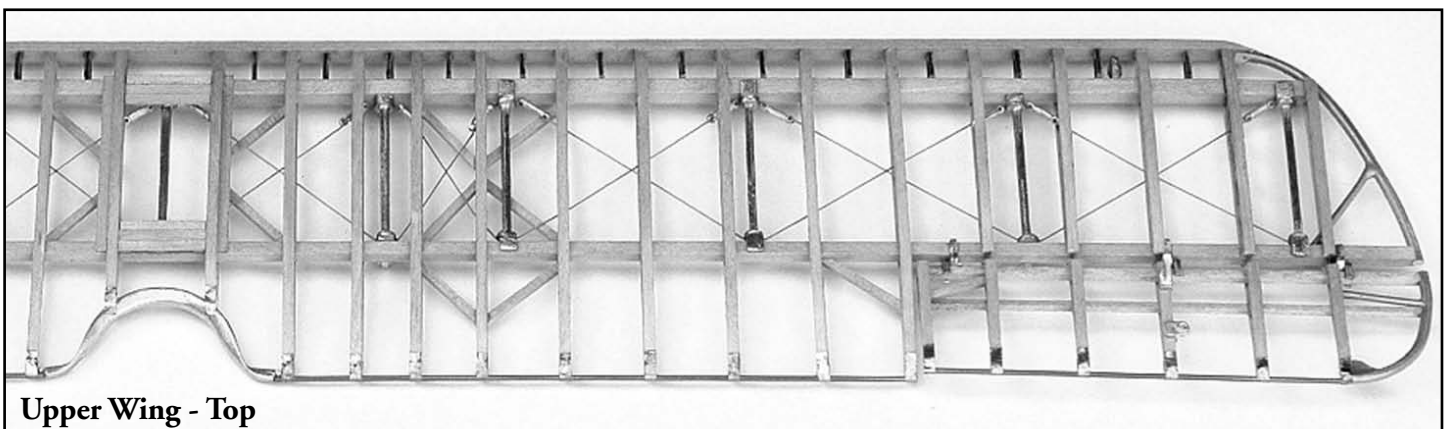
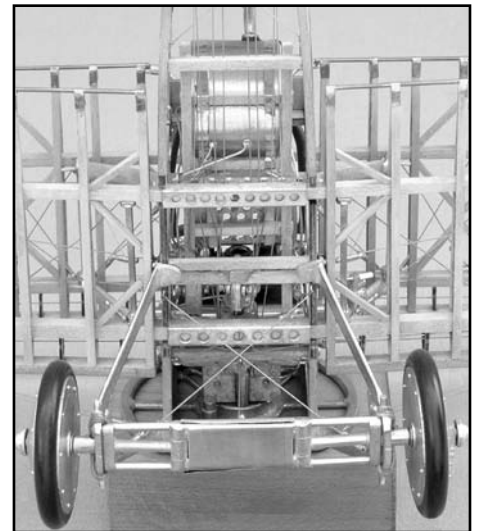
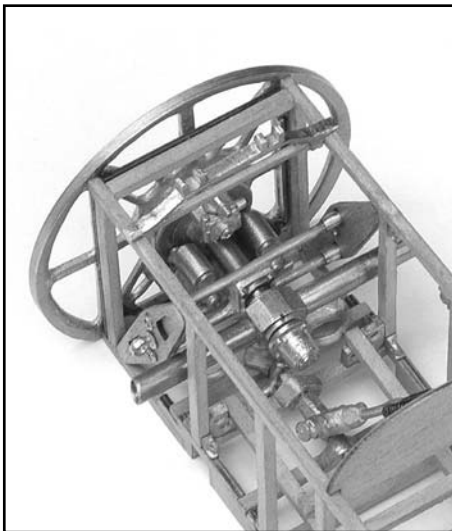
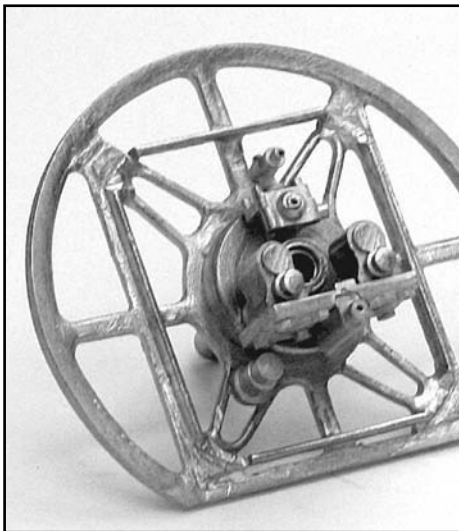

Upper Wing - Top

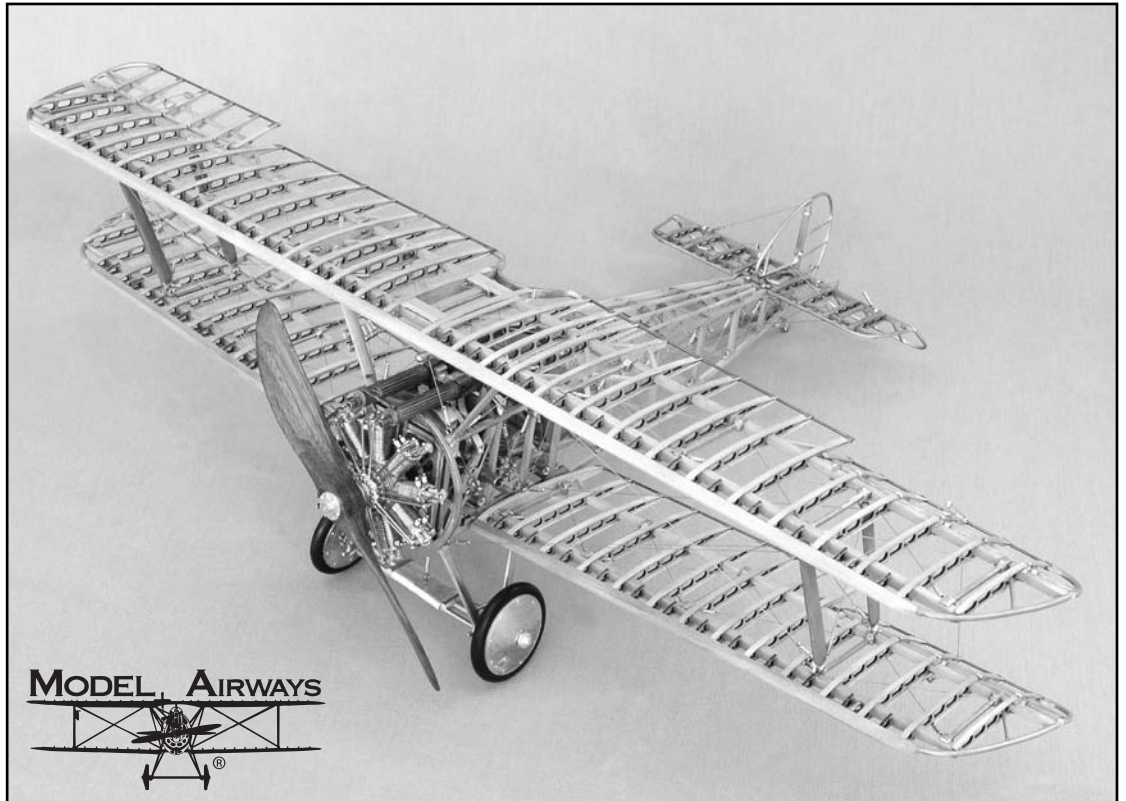
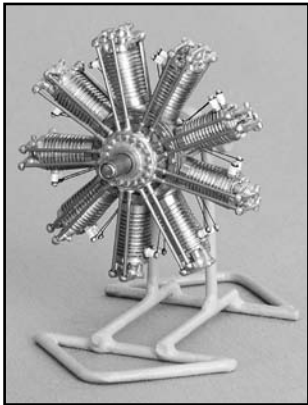
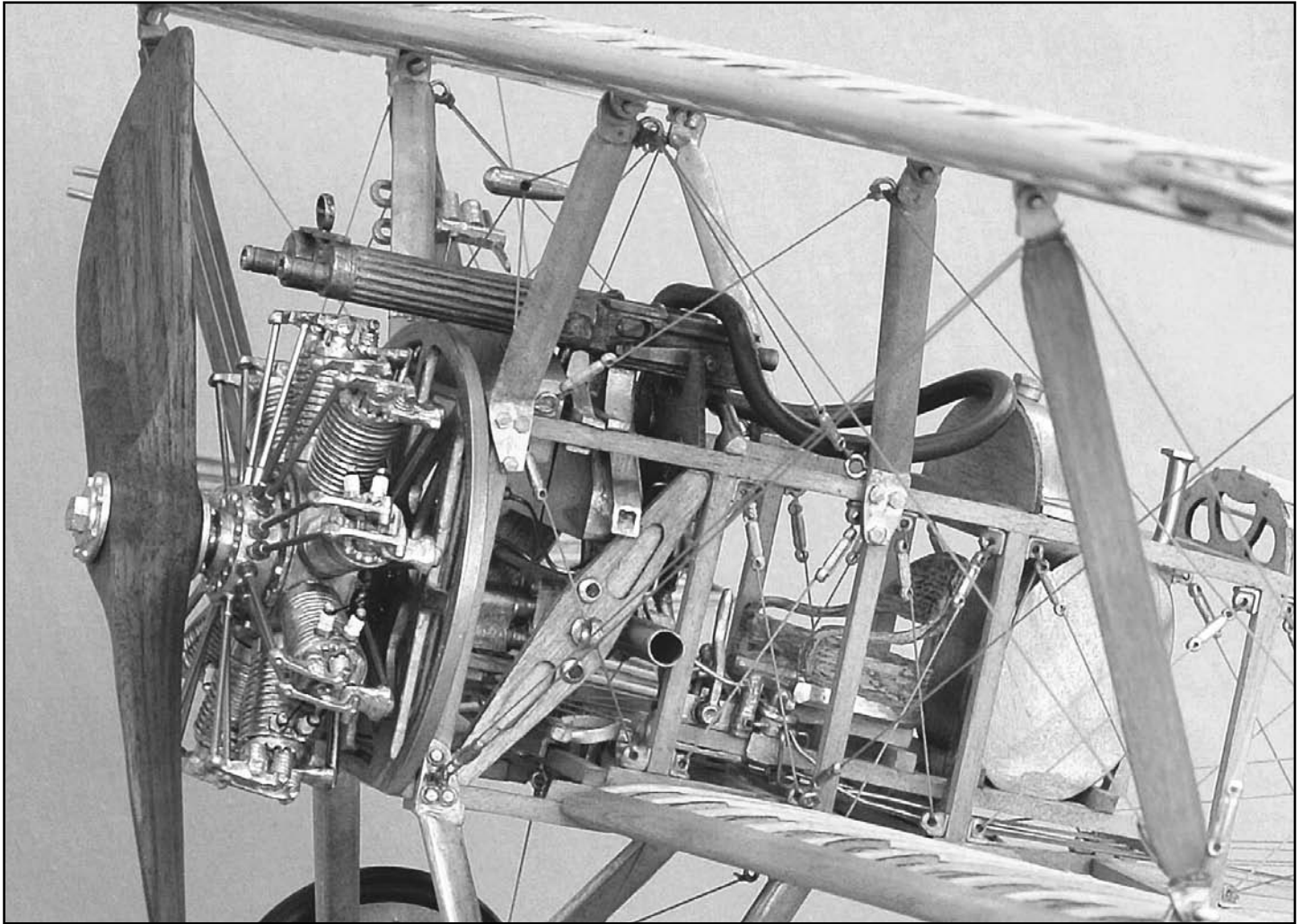

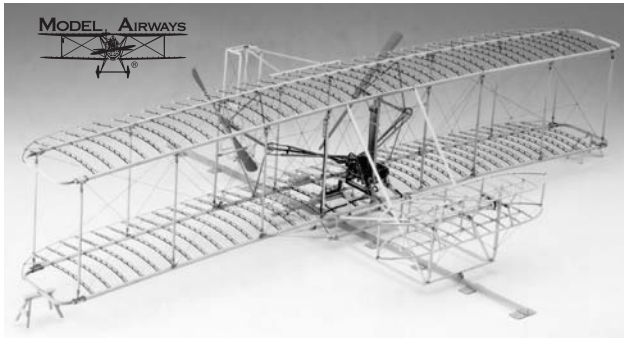

**THE WRIGHT FLYER, 1903**

**1:16 SCALE WOOD & PHOTO-ETCHED BRASS KIT**

Our latest entry into the world of historic wood airplane kits is the most detailed and accurate Wright Flyer kit ever made! This true-to-life static model reproduces virtually every detail of the real aircraft. We've designed our model without the customary fabric covering to show its fascinating structural components.

Kit contains laser cut basswood parts for ribs and other wooden components plus a host of Britannia metal parts for building the engine, complete with cylinders, magneto and radiator. We include brass chain and over 160 photo-etched brass parts for fittings and braces to simulate the Wright Brothers' construction methods. Three detailed, actual size plan sheets and a 28-page illustrated step-by-step assembly manual will assist both novice and expert modelers in the completion of a museum quality model.

**Model Airways**

**Kit No. MA1020**

Wingspan 30"

Length 15"

Scale 1:16 (3/4" = 1')

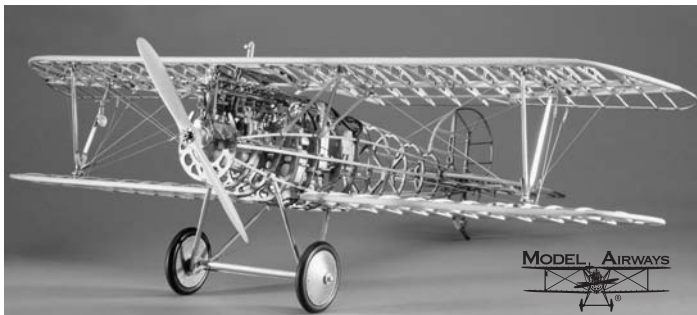

**ALBATROS D.VA - THE RED BARON'S FORGOTTEN FIGHTER!**

The Albatros D.Va from Model Airways is sure to impress any modeler looking for superior detail, unsurpassed authenticity and uncompromising quality of materials. Four sheets of blueprint quality plans and a 48 page illustrated instruction manual help pave the way to a museum quality masterpiece. Order the Albatros D.Va now for the modeling adventure of a lifetime!

- 184 basswood, birch and plywood parts, most laser cut
- Over 100 Britannia metal parts for building the 180 HP six cylinder Mercedes-Benz motor
- Two 30 caliber machine guns cast in Britannia metal
- Four actual size plan sheets with illustrations of all laser cut wooden parts
- 48 page step-by-step photo instruction manual to assist novice and expert modelers to the completion of a museum quality model.
- Over 200 copper, aluminum, steel, rubber and Britannia metal parts used as turnbuckles for guy wires, suppression bars, pulleys, wire support brackets, ailerons, stabilizers, struts, flight instruments, wheels, tires.

**Model Airways**

**Kit No. MA1001**

Wingspan 32-1/2"

Length 20-1/2"

Scale 1:16 (3/4" = 1')

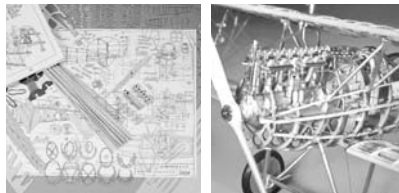

**AMERICA'S MOST FAMOUS BIPLANE**

**CURTISS JN4D 'JENNY' BIPLANE TRAINER, 1917**

After many years of research, we're proud to bring you our 1:16 scale model, which reproduces virtually every detail of the real aircraft. The kit includes over 300 laser cut basswood and birch parts for ribs, fuselage and other wooden components. The Curtiss OX-5 in-line V8 water-cooled engine, assembled from over 100 finely cast Britannia metal parts, is complete with cylinders, distributor, spark plugs and crankcase. You'll use close to 600 highly detailed photo-etched parts for the aluminum cowl and seats, copper turnbuckles and other wing and fuselage fittings. We even include photo-etched nickel silver wheel spokes! Six highly detailed, actual size plan sheets illustrated step-by-step instruction manual assist you in the completion of a museum quality model.

**Intermediate Level**

**Model Airways**

**Kit No. MA1010**

Wingspan 32-1/2"

Fuselage Length 20-1/2"

Scale 1:16 (3/4" = 1' 0")

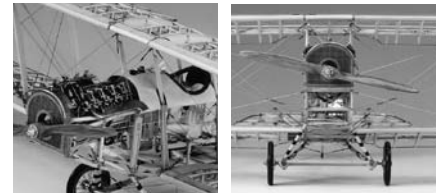

**NIEUPORT 28, 1917  
EDDIE RICKENBACKER'S FAVORITE FIGHTER!**

Model Airways has gone to great lengths to recreate this legendary World War I fighter. We've designed our Nieuport 28 from original plans, photographs and restored aircraft on display in several museums. The historically accurate model reproduces virtually every detail of the real airplane. The open framework allows for authentic detailing and shows the intricacies of construction. Kit contains over 190 laser cut basswood and birch plywood parts for ribs, fuselage and other wooden components. Hundreds of finely cast Britannia metal, copper, aluminum, brass and rubber parts make up the instrument panel, fuel tank, turnbuckles, ailerons, struts, compression bar, stabilizers, machine guns, wheels, tires and more. A perfectly scaled rotary engine- complete with cylinders, distributor, spark plugs and crankcase is also assembled from Britannia metal castings. Three sheets of plans and an explicitly illustrated, step-by-step instruction manual will assist novice and expert modelers in the completion of a museum quality model.

**Intermediate Level**

**Model Airways**

**Kit No. MA1002**

Wingspan 20"

Fuselage 15-3/4"

Scale 1:16 (3/4" = 1 ft.)

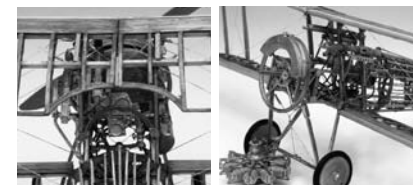

**Buy direct from our website [www.modelexpo-online.com](http://www.modelexpo-online.com)**

for current prices and other great Model Airways, Model Shipways and Guns of History kits.

We also carry Guillow's balsa airplane kits, hobby tools, books, glues, paints, & much more!