

DRAGONFLY

14+
THIS IS NOT
A TOY



Model No:6302

IMPORTANT NOTE:

J4C03 2.4GHz 4CH transmitter is supplied with MODE 2 as standard set, If needed, you could simply switch to MODE 1 by easy steps, see details in page 9.



SPECIFICATION:

- Wing span: 700mm
- Wing loading: 25g/dm²
- Fuselage length: 970mm
- Flying weight: 575g
- Motor thrust power: 850g

***ATL Sport Model
All Terrain Launching R/C Brushless Airplane***

INSTRUCTION MANUAL **THIS MODEL IS NOT A TOY!**

THESE INSTRUCTIONS SHOULD BE READ BY A SUPERVISING ADULT

Dragonfly All Terrain Launching Airplane PNP

Model No:6302

WARNINGS

IMPORTANT: Before beginning assembly, please read and understand the warnings listed following. Failure to read and understand these warnings could lead to bodily harm and/or injury.

1. This model is not a toy. It is for beginner, intermediate and experienced modeller
2. Assemble the plane according to the instructions. Do not alter or modify the model. If you make any modifications, you will void your warranty.
3. It is highly recommended to fly this model under the guide of experienced modeller
4. Test the operation of the model before each flight to insure that all equipment is operating properly, and that the model remains structurally sound.
5. Fly in large open areas free of trees, people, buildings or any other obstacles.
6. Always be conscious of the spinning propeller. Be careful not to allow loose clothing to be drawn into the propeller.
7. Always turn on the transmitter before turning on the airplane and always turn off the airplane before turning off the transmitter.
8. Always unplug the flight battery when not flying the airplane.
9. Do not attempt to catch the airplane while flying.
10. It is important to make sure you are always using fresh or fully charged batteries. Never allow the batteries to run low or you could lose control of the airplane.

FCC REQUIREMENT



This device complies with Part 15 of the FCC Rules. Operation is subject to the following two conditions: (1) This device may not cause harmful interference, and (2) This device must accept any interference received, including interference that may cause undesired operation.

CAUTION: Changes or modifications to this product not expressly approved by the party responsible for compliance may void the user's authority to operate the equipment.

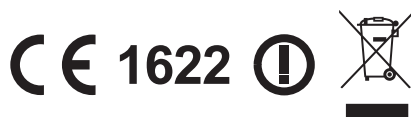

KIT CONTENTS



Fuselage



Left wing Right wing

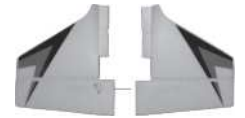

Right horizontal tail
Left horizontal tail



Electronic compartment hatch



Battery compartment hatch



6*4*400mm carbon fiber tube
6*4*200mm carbon fiber tube
3*1.4*120mm carbon fiber tube



Y wire cord



Push rod for horizontal tail



1.5mm Allen key



Cohere sticker for horizontal tail
Battery velcro



Spare 6*4 propeller



Ballon



11.1V 1200mAh LiPo
(Optional Part)



2.4GHz 4CH Transmitter and Receiver
(Optional Part)

ITEMS REQUIRED FOR COMPLETION

2.4GHz 4CH Transmitter and Receiver.

11.1V 1200mAh 20C LiPo pack. (Battery capacity can be from 1200mAh to 2200mAh)

2S/3S Balance charger with adapter.

ASSEMBLING YOUR DRAGONFLY

1. Remove battery compartment hatch and electronic compartment hatch as photos show.
2. Rip off the double side tape on the left wing as photos show.

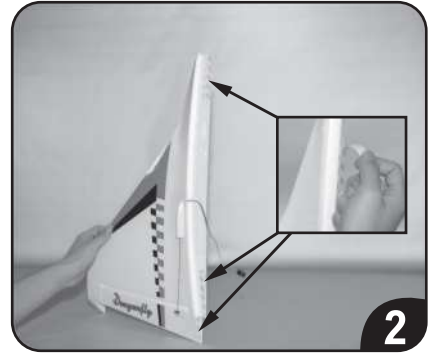

3. Insert servo extend wire into the fuselage hole. plug in left wing with fuselage and press them together so that double side tape could secure them.

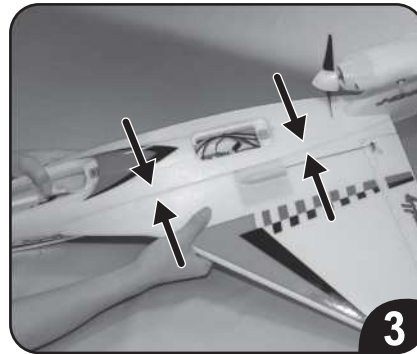
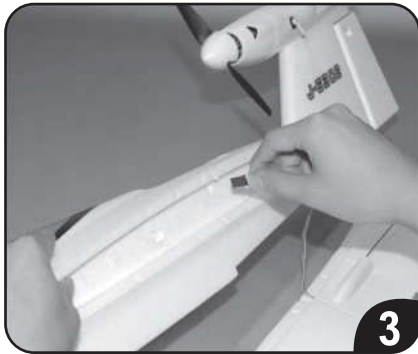

4. Insert 6*3*200mm carbon fiber tube from right side of fuselage through wing as photo show. Follow the above way to insert 6*3*400mm carbon fiber tube on fuselage through wing.

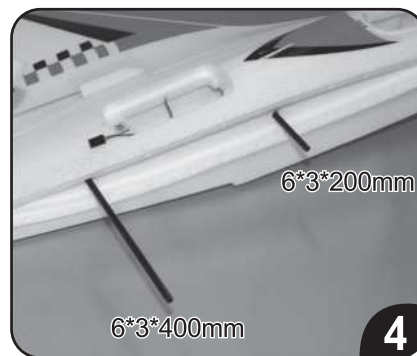
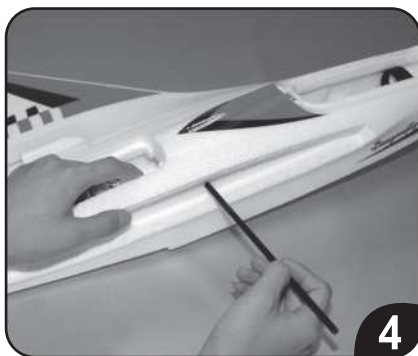

5. Rip off right wing double side tape, align carbon fiber tube with two holes on right wing side and press right wing to join fuselage. before they join together, make sure the servo extend wire get through the hole on fuselage. the servo extend wire can't be stuck when right wing join with fuselage.

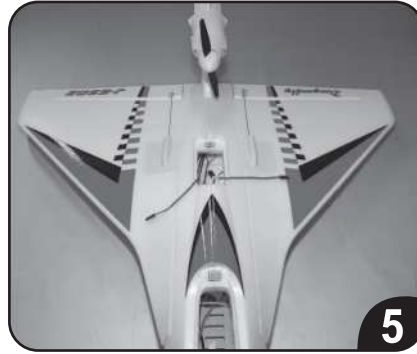
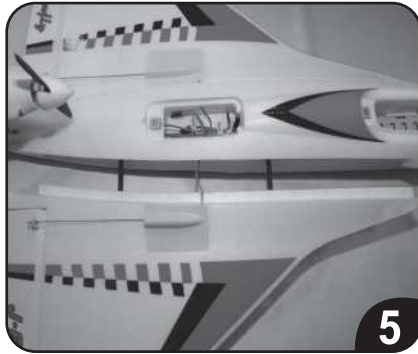

6. plug in the two servo extend wire on wings with Y wire cord which has Aileron marking label. Noticing the servo wire correct polarity.

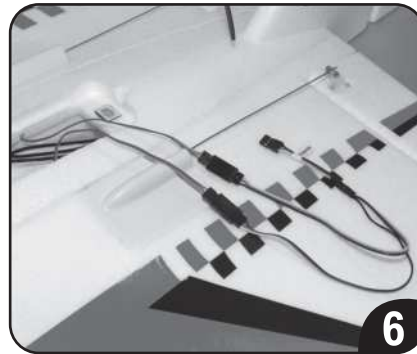
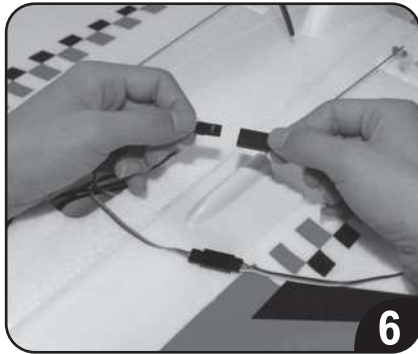

7. Insert left horizontal tail into left side of fuselage as show.

8. Insert 3*1.4*120mm carbon fiber tube from right side fuselage through left horizontal tail as show.

9. Align two carbon fiber tubes with two holes on right horizontal tail and install right horizontal tail.

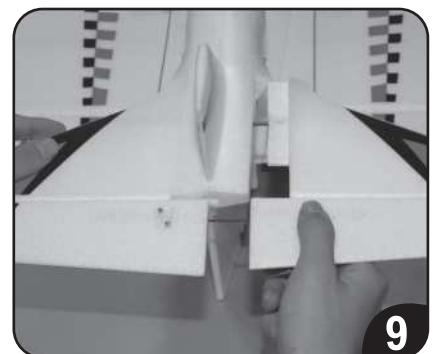
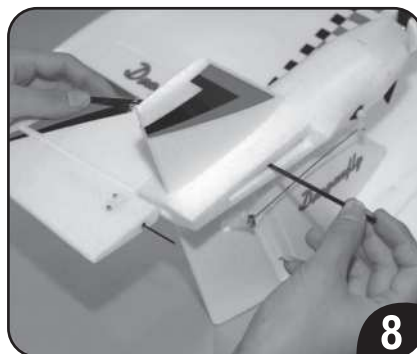
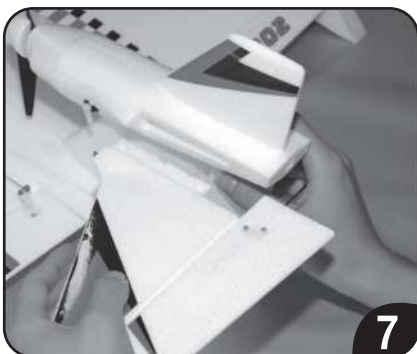

8. Use two pcs of cohere sticker to join two horizontal tails together up and down.

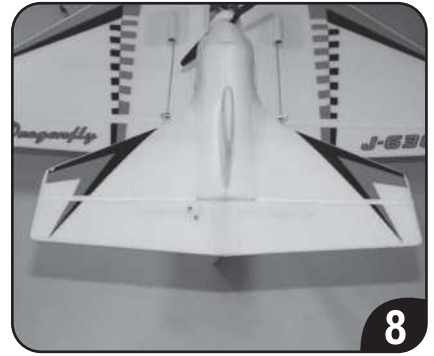
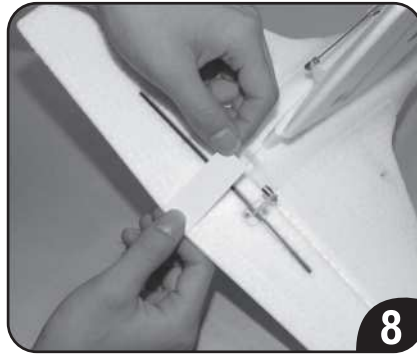
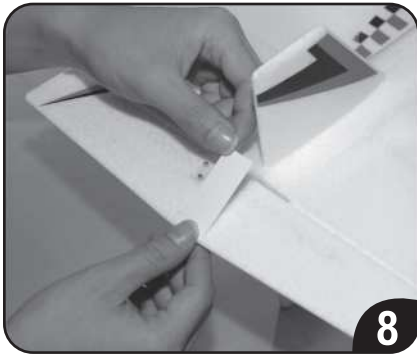

9. Insert Z shape end of pushrod into the outer hole of servo arm as show. The other end of pushrod get through the clevis and secure it with 1.5mm allen key as show. make sure horizontal tail are in neutral position.

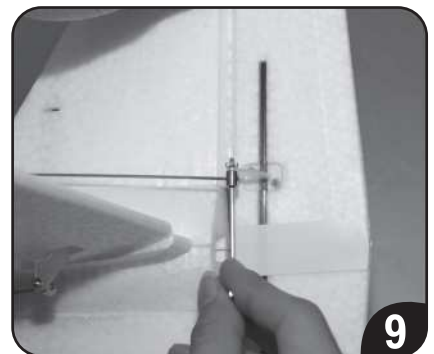
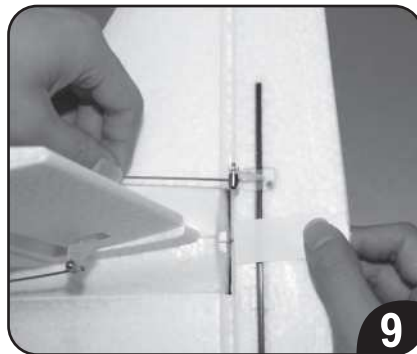
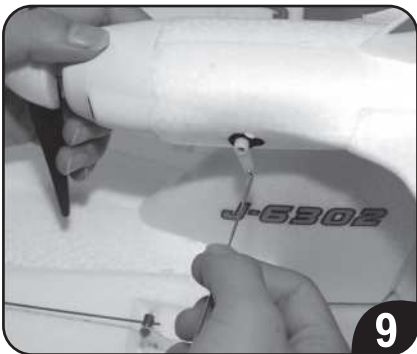

Servo wires connecting to Receiver (Apply to MODE 1 and MODE 2)

1. Plug in Aileron servo wire with Channel 1.
2. Plug in Elevator servo wire with Channel 2.
3. Plug in Throttle wire with Channel 3.
4. Plug in Rudder servo wire with Channel 4.
5. Wrap receiver with supplied ballon and place it well inside the electronic compartment. then reinstall the hatch.

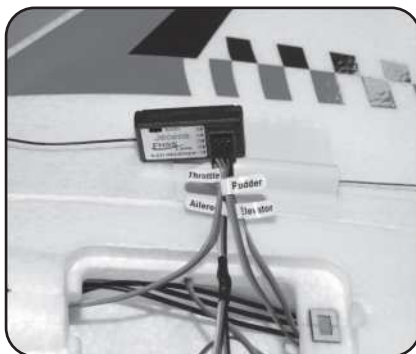

PREPARATION BEFORE FLIGHT

STEP 1: INSTALLING THE TRANSMITTER BATTERIES

1. Carefully remove the battery cover from the back of the transmitter by pulling down on it with one hand while holding the transmitter with your other hand.
2. Install 4 fresh AA Alkaline batteries, being careful to make sure that the polarity is correct for each battery.
3. After double-checking that the batteries are installed correctly, reinstall the battery cover, making sure it's firmly seated into place.



STEP 2: CHARGING THE LIPO PACK (NOT INCLUDED)

The following parts are optional purchasing parts.

11.1V 1200mAh 20C LiPo pack.

2S/3S Balance charger with adapter

NOTE: Familiarize yourself with the charging procedure of the lipo battery. Read the charger Manual completely and fully charge the lipo battery.

CAUTION:

1. Only use a LiPo approved charger. Never use a NiCd/NiMH peak charger!
2. Never leave the battery unattended during the charging process. Always keep this charger out of reach of children.
3. Stop charging immediately if any abnormality occurs, such as power indicator is off, the temperature of the battery raise rapidly.
4. Do not attempt to disassemble the charger
5. Do not set the charger on carpet during the charging process.
6. Un-plug the charger DC Adapter from the vehicles's cigarette lighter if you do not intend to use it for a period of time.

STEP 3: INSTALLING THE LIPO PACK

IMPORTANT Always turn on the transmitter before turning on the airplane and always turn off the airplane before turning off the transmitter.

1. Push down the throttle stick (Left Stick, MODE 2) till the end as shown. Switch off "MXMD" button on top position, because Dragonfly don't need mix control function on wing or tail. Then turn on the transmitter by pressing on the power switch.



2. Put LiPo pack inside the fuselage, using hook and loop strap to secure them tightly on position.
3. Attach the battery connector to the matching connector of ESC. And reinstall the hatch of fuselage, making sure it is secured tightly.
4. The proper CG position should be 10mm away from the cutting edge of bottom fuselage, please refer to the picture. If not, please adjust the position of battery.

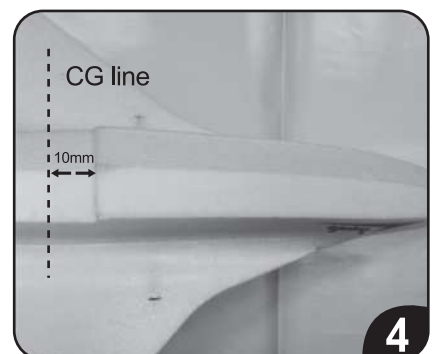
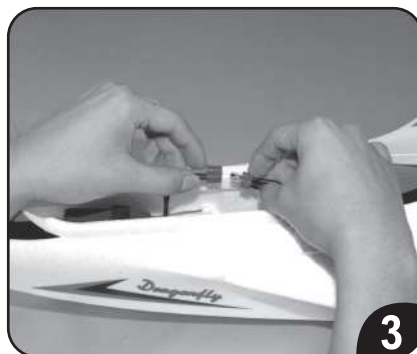

STEP 4: FAMILIAR WITH RADIO CONTROL SYSTEM

Mode 1

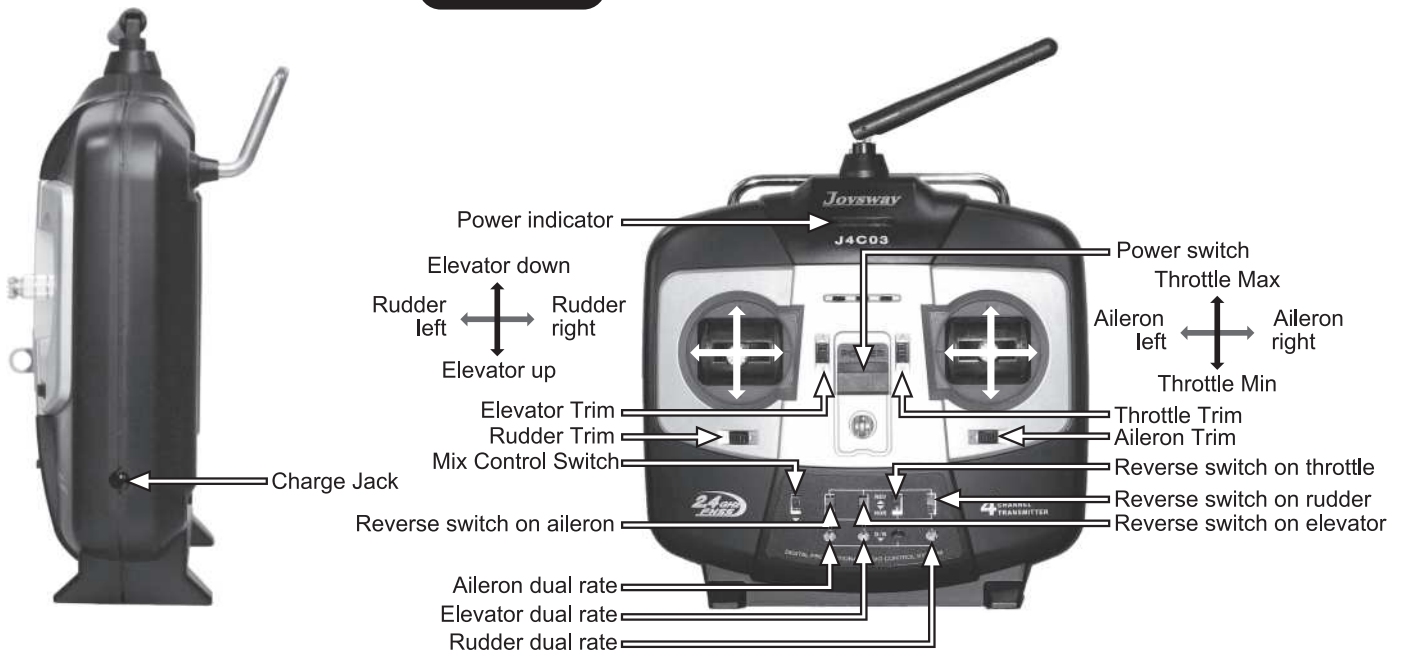

Mode 2

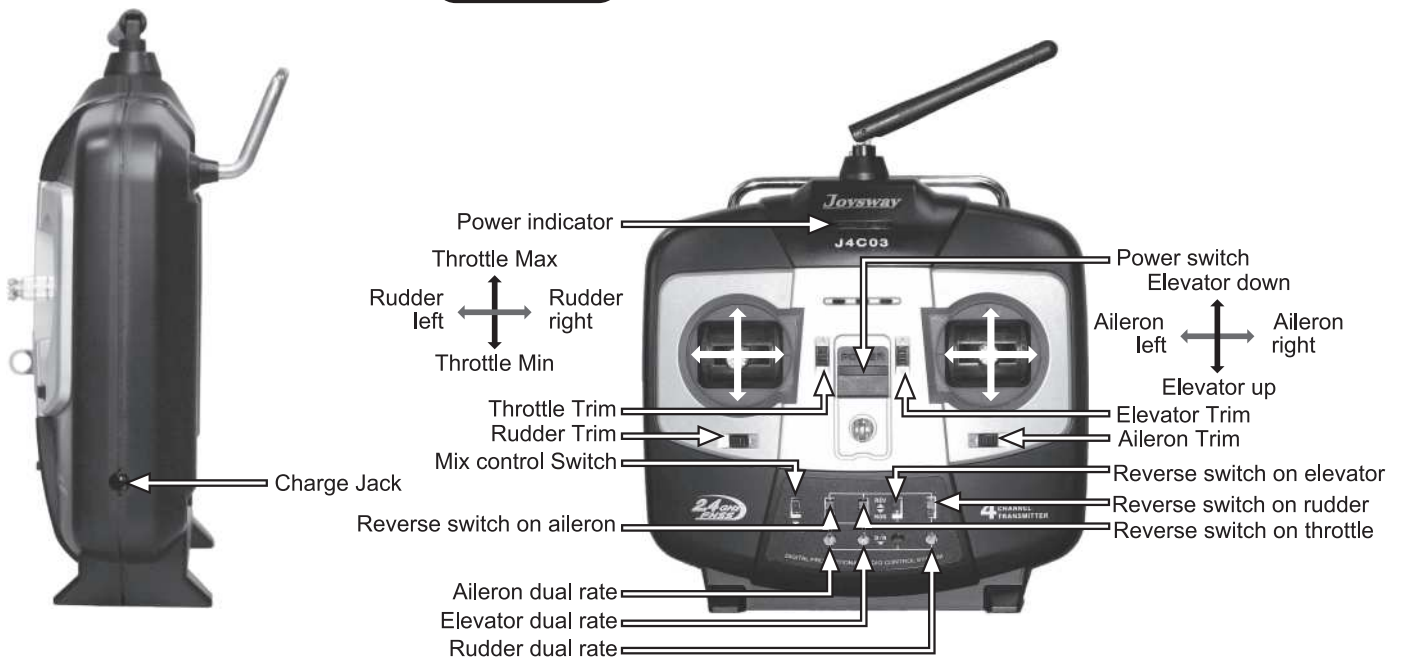

NOTE:

1. MXMD button is mix control ON/OFF button, switch down as "ON" if model is with mix control function. Otherwise switch up as "OFF".
2. Supplied plastic screwdriver on transmitter handle, use this part to adjust Aileron, Elevator, Rudder dual rate.

TRANSMITTER MODE SWITCHING

J4C03 2.4GHz 4CH transmitter is supplied with MODE 2 as standard set, If needed, you could simply switch to MODE 1 by easy steps as belowing:

Step 1: Open battery cover, switch MODE button to MODE 1.

Step 2: Use screwdriver to screw down the up-left screw tightly as photo shown.

Step 3: Screw down the down-left screw as photo shown, but not fully tighten, adjust this screw tightness so as to adjust the throttle stick (right stick) spring tightness as you wanted.

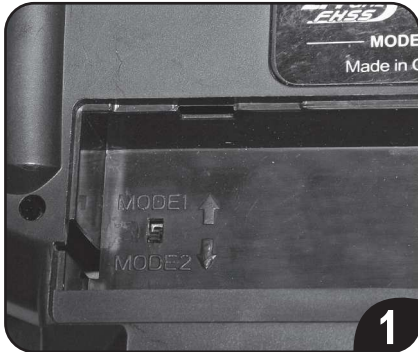

Step 4: Screw off down-right screw completely until the screw head is almost even with back panel.

Step 5: Screw off up-right screw, but not completely. adjust this screw tightness so as to adjust the Elevator stick(left stick) spring tightness as you wanted.



NOTE: If switch back form MODE 1 to MODE 2, firstly switch MODE button to MODE 2 under battery cover, screw off the left two screws, Screw down the right two screws, adjust down-left and up-right screws tightness so as to adjust the Throttle stick and Elevator stick spring tightness as you wanted.

CHARGING(FOR RECHARGEABLE BATTERIES)

The J4C03 transmitter has a charge jack that allows rechargeable AA cells (not included) to be charged in it, using a suitable battery charger.(Output: 6V, Max500mA)

Caution: Never try to charge dry cell batteries in the transmitter. They will leak and could explode!

Caution: Never leave the radio/charger unattended when charging.

Caution: To prevent the possibility of accident, overheating and/or short circuit, always disconnect your battery charger from its power supply when not in use.

Note: When rechargeable batteries are finally depleted (dead) they should be taken to a designated recycling centre for disposal. DO NOT dispose of them in household waste.



TRANSMITTER/RECEIVER BINDING

The binding process effectively ties the J4C03 transmitter and J5C01R receiver together. Under normal circumstances, both items are supplied like this from the factory. If, however, you find that your transmitter and receiver are not bound (receiver's red LED will be lighting), you should do the following:

1. Push down the throttle stick (Left Stick, MODE 2) till the end as shown. Switch "ON" the transmitter.
2. Connect LiPo pack to ESC's matching connector
3. Press down the "BIND" button on the receiver as shown, until the receiver's red LED flash then let go, the receiver's green LED will be lighting to indicate that binding has been successful and the receiver will now accept commands from the transmitter.

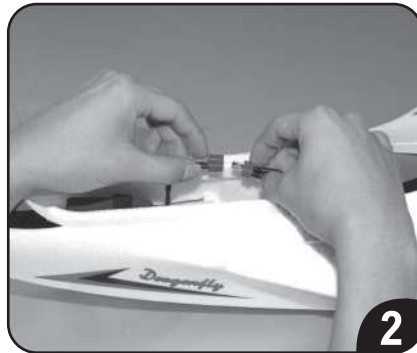

Note 1: You would also need to carry out the binding process if you were to replace the included receiver with another one.

Note 2: Typically, for the binding process to be effective, transmitter and receiver should be no more than one meter apart and no other similar devices should be within 10 meters of both during setup.

STEP 5: TEST THE THROTTLE (Mode 2)

1. Move the throttle control stick forward slowly, the motor rotates faster gradually.

NOTE: If the motor doesn't react with the throttle increasing, please check the power supply or the battery capacity and the throttle reverse switch and make necessary adjustment.

WARNING: Keep everything clear of the propeller once the battery is plugged in. Do not try to stop the propeller by hand or anything else.

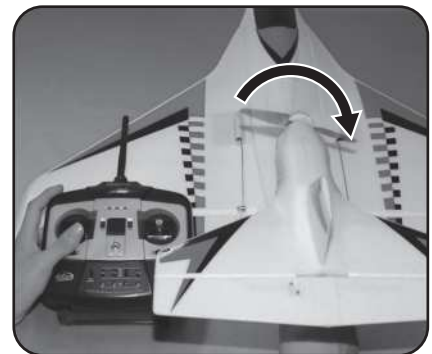

STEP 6: TEST THE AILERON (Mode 2)

1. Move the aileron control stick to the left, the left aileron moves up and the right aileron moves down.
2. Move the aileron control stick to the right, the left aileron moves down and the right aileron moves up.

NOTE: If the movement of aileron works in opposite position, please check the aileron reverse switch and make necessary adjustment.

3. Let Aileron control stick returns to its neutral position, the aileron returns to its neutral position.

NOTE: If aileron doesn't return to neutral position, then adjust the aileron trim button to make it in neutral position.

REMARK: You could adjust the aileron servo traveling value by using the plastic screwdriver to adjust the aileron dual rate on transmitter.

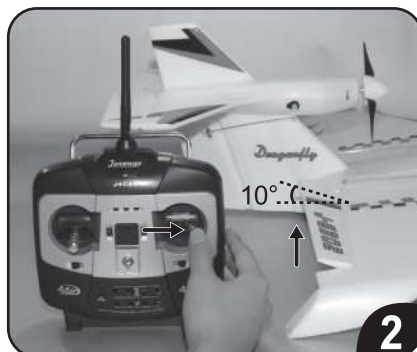

STEP 7: TEST THE RUDDER (Mode 2)

1. Move the rudder control stick to the left, the rudder turns to the left.
2. Move the rudder control stick to the right, the rudder turns to the right.

NOTE: If the movement of rudder works in opposite position, please check the rudder reverse switch and make necessary adjustment.

3. Let rudder control stick returns to its neutral position, the rudder returns to its neutral position.

NOTE: If rudder doesn't return to neutral position, then adjust the rudder trim button to make it in neutral position

REMARK: You could adjust the rudder servo traveling value by using the plastic screwdriver to adjust the rudder dual rate on transmitter.

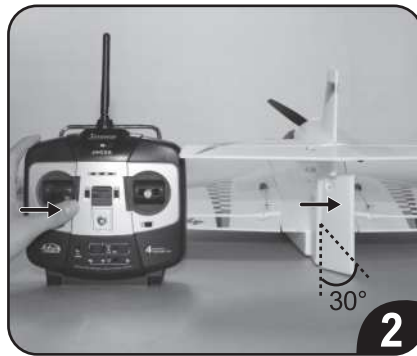

STEP 8: TEST THE ELEVATOR (Mode 2)

1. Move the elevator control stick backward, the elevator will be up
2. Move the elevator control stick forward, the elevator will be down.

NOTE: If the movement of elevator works in opposite position, please check the elevator reverse switch and make necessary adjustment.

3. Let elevator control stick returns to its neutral position, the elevator returns to its neutral position.

NOTE: If elevator doesn't return to neutral position, then adjust the elevator trim button to make it in neutral position.

REMARK: You could adjust the elevator servo traveling value by using the plastic screwdriver to adjust the elevator dual rate on transmitter.

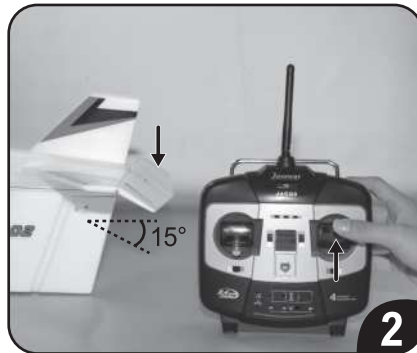
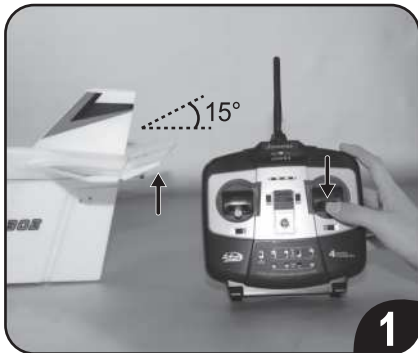

FLIGHT MANUAL

Choose a good flying site and day

1. The ideal location for flying has wide-open space in four directions with no people
2. Choose location carefully! Do not operate model near these areas: Houses or buildings, children's play areas, road traffic, railways, airports, overhead powerlines.
3. Fly in calm weather conditions with no winds or gentle winds.

WARNING: If you lose control of your airplane, never wade into deep water or water with strong currents to retrieve it. First, hold the transmitter as high as you can to try to re-establish control. If this does not work, find another way to move closer to the model, but do not endanger yourself in the process!

Pre-flight check

1. Check the propeller and all screws are securely fastened.
2. Check airplane responds properly to control signals.
3. Test the range of the radio signal. It is recommended that have around 100 M range check.

VALUABLE EXPERIENCE

Take Off

1. Place airplane on water gently, apply half throttle, adjust rudder stick to control airplane sliding on water and facing the wind.
2. Apply full throttle and adjust rudder stick to control airplane sliding in high speed on water straightly facing the wind.
3. When airplane is sliding in high speed straightly, apply adequate amount of elevator, airplane head will raise and going to take off

NOTE: When airplane take off, immediately reduce elevator control value to control airplane ascend slowly.

Steering

1. Aileron control to steer left, move aileron stick to left, combine with a small amount of up elevator (Elevator stick down), airplane will steer left without losing altitude
2. Aileron control to steer right, move aileron stick to right, combine with a small amount of up elevator (Elevator stick down), airplane will steer right without losing altitude.
3. Rudder control to steer left, move rudder stick to left, combine with a small amount of up elevator (Elevator stick down), airplane will steer left without losing altitude
4. Rudder control to steer right, move rudder stick to right, combine with a small amount of up elevator (Elevator stick down), airplane will steer right without losing altitude

Landing

1. For your first couple of flights we recommend that you attempt to land with reserve battery power.
2. During your first flight, while at a high altitude, turn the motor off and notice how the Dragonfly seaplane reacts. This will give you an idea of how the airplane will react during a landing. At this higher altitude, familiarize yourself with how the model responds at low power and slower speeds as this is how the model will fly when landing.
3. To land the Dragonfly seaplane, fly down wind, past the landing area. Gently turn into the wind and reduce the throttle so that the airplane starts to come down. Adjust the throttle as needed to reach the landing area, but not fly past it. Always land into the wind.
4. Just before landing on water, at about 0.5 meter above the water, apply a little up elevator, This will cause the airplane to slow and settle on the water.

After Landing

Disconnect the battery, then, switch the transmitter off. Remove the battery from the fuselage, Check the airplane over to make sure nothing has come loose or may be damaged.

Command And Fly (Mode 2)

Speed up			Left stick up
Speed down			Left stick down
Ascending			Right stick down
Descending			Right stick up
Nose turn right			Left stick right
Nose turn left			Left stick left
The Body incline to Right			Right Stick Right
The Body incline to Left			Right Stick Left

Adjusting trims during flight (Mode 2)

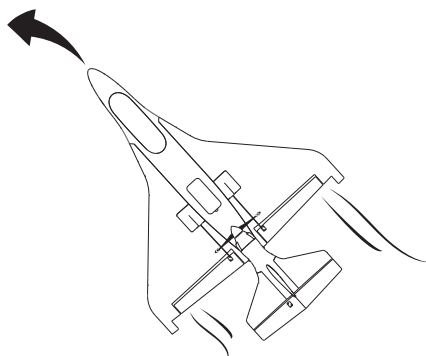

Rudder Trim



1. Let go of control sticks. If airplane moves left, adjust rudder trim to the right.

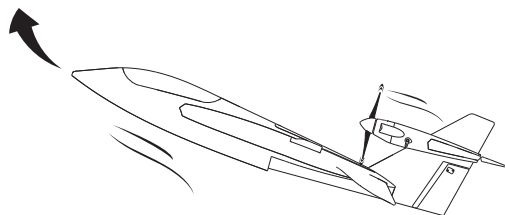

Elevator Trim



2. Let go of control sticks. If airplane moves upward, adjust elevator trim to downward.

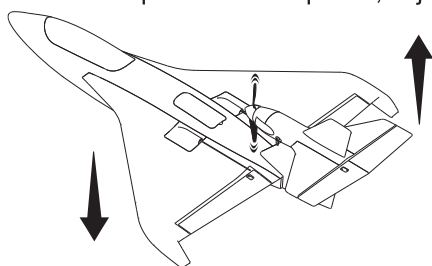

Aileron Trim



3. Let go of control sticks. If airplane inclines to the left, adjust aileron trim to the right.

4. Adjust rudder, elevator and aileron trims so airplane flies straight and horizontal when sticks are free.

SPARE PART LIST

To order Dragonfly seaplane spare parts, use the part numbers in the spare parts list that follows.

PART NO.	DESCRIPTION
630201	Brushless motor and motor mount
630202	11.1V 1200mAh 25C LiPO Pack
630203	40A brushless ESC
630204	Elevator/Rudder servo(PK2)
630205	Aileron servo (PK2)
630206	Main EPO Hatch without magnet
630207	elevator tail set
630208	motor and servo hatch cover
630209	left wing set
630210	right wing set
630211	pushrod for aileron (PK2)
630212	Wing attachment tube (PK2)
630213	Clevis (PK2)
630214	pushrod for elevator (PK2)
630215	pushrod for rudder (PK2)
630216	Fuselage set
630217	Velco strap for battery(PK2)
630218	Propeller and spinner set (PK2)
630219	Magnet set for hatch(PK2)
630220	Receiver EPO hatch
630221	Decal stickers set for fuselage and wing
610206	Control Horn set(PK6)
610307	3S balance charger with DC adapter



www.Joysway-Hobby.com