

T-28 Trojan 450mm

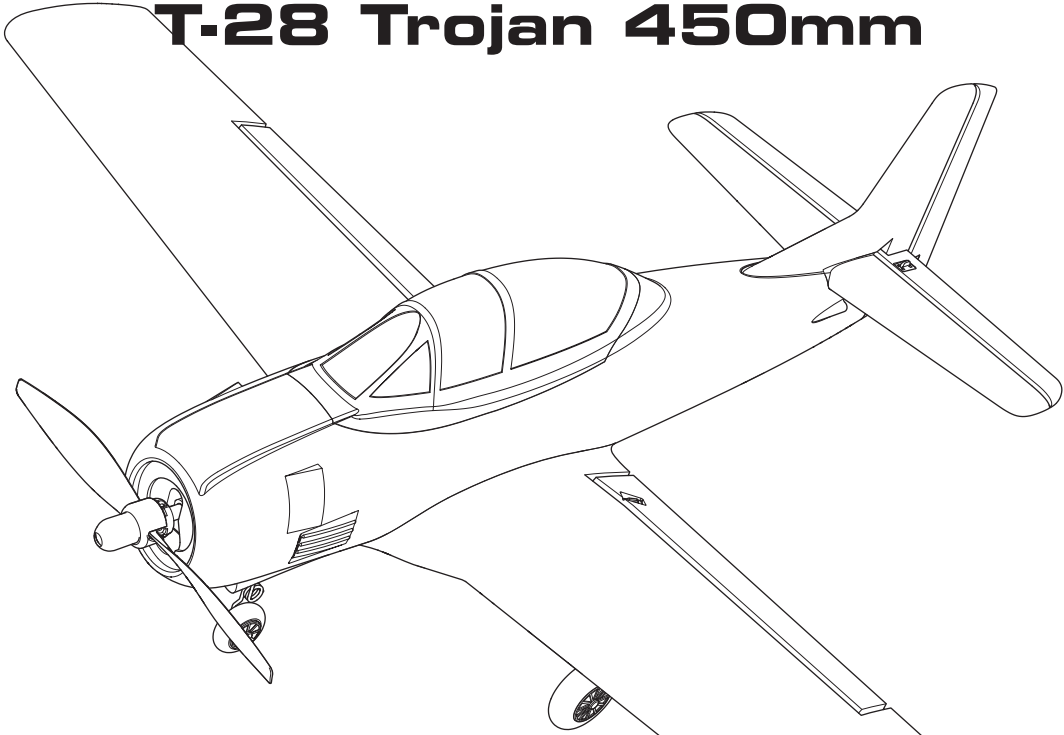

Scan the QR code and select the Manuals and Support quick links from the product page for the most up-to-date manual information.

Scannez le code QR et sélectionnez les liens rapides Manuals and Support sur la page du produit pour obtenir les informations les plus récentes sur le manuel.



HBZ-1228

Instruction Manual Manuel d'utilisation

NOTICE

All instructions, warranties and other collateral documents are subject to change at the sole discretion of Horizon Hobby, LLC. For up-to-date product literature, visit www.horizonhobby.com or www.towerhobbies.com and click on the support or resources tab for this product.

Meaning of Special Language:

The following terms are used throughout the product literature to indicate various levels of potential harm when operating this product:

WARNING: Procedures, which if not properly followed, create the probability of property damage, collateral damage, and serious injury OR create a high probability of superficial injury.

CAUTION: Procedures, which if not properly followed, create the probability of physical property damage AND a possibility of serious injury.

NOTICE: Procedures, which if not properly followed, create a possibility of physical property damage AND little or no possibility of injury.

 **WARNING:** Read the ENTIRE instruction manual to become familiar with the features of the product before operating. Failure to operate the product correctly can result in damage to the product, personal property and cause serious injury.

This is a sophisticated hobby product. It must be operated with caution and common sense and requires some basic mechanical ability. Failure to operate this Product in a safe and responsible manner could result in injury or damage to the product or other property. This product is not intended for use by children without direct adult supervision. Do not use with incompatible components or after this product in any way outside of the instructions provided by Horizon Hobby, LLC. This manual contains instructions for safety, operation and maintenance. It is essential to read and follow all the instructions and warnings in the manual, prior to assembly, setup or use, in order to operate correctly and avoid damage or serious injury.

AGE RECOMMENDATION: Not for children under 14 years. This is not a toy.

Safety Precautions and Warnings

This model is controlled by a radio signal subject to interference from many sources outside of your control. Interference can cause momentary loss of flight control.

As the user of this product, you are solely responsible for operating in a manner that does not endanger yourself and others or result in damage to the product or the property of others.

- **NEVER** operate the aircraft under the influence of drugs or alcohol.
- **NEVER** place any portion of the model in your mouth as it could cause serious injury or even death.
- **NEVER** operate the aircraft with damaged wiring or components.
- **NEVER** touch moving parts.
- **NEVER** operate the aircraft in the rain.
- **NEVER** fly over people, roadways, structures, power lines or near airports.
- **NEVER** attempt to fly from a vehicle or from within a structure.
- **NEVER** perform maintenance on the aircraft with the battery installed.
- **NEVER** use a damaged or deformed battery.
- **ALWAYS** treat the motor and propeller as if they are armed and could start at any time.
- **ALWAYS** ensure the transmitter is secure before and while the aircraft is powered on.
- **ALWAYS** keep body parts and loose clothing well clear of the propeller/rotor blades.
- **ALWAYS** keep the aircraft securely restrained in case of accidental throttle activation.
- **ALWAYS** perform a maintenance check on the aircraft and transmitter prior to and after every flight to ensure airworthiness.
- **ALWAYS** operate the aircraft in open spaces, away from full-size vehicles, traffic and people.
- **ALWAYS** keep the aircraft in sight and under control.
- **ALWAYS** keep a safe distance in all directions around your model to avoid collisions or injury.
- **ALWAYS** fully reduce the throttle or activate throttle cut before a crash.
- **ALWAYS** keep the transmitter powered on when the aircraft is powered on.
- **ALWAYS** carefully follow the directions and warnings for this and any optional support equipment (chargers, rechargeable battery packs, etc.).
- **ALWAYS** keep all chemicals, small parts and anything electrical out of the reach of children.
- **ALWAYS** use fully charged batteries.
- **ALWAYS** let parts cool after use before touching.
- **ALWAYS** keep moving parts clean.
- **ALWAYS** keep parts dry.
- **ALWAYS** remove batteries after use.

Registration

Register your product today to join our mailing list and keep up to date with product updates, offers and HobbyZone® news.



Table of Contents

Aircraft Components	4
Preflight Checklist.....	5
Charging Warnings.....	5
Charge the Flight Battery	5
Assemble the Aircraft.....	6
Install the Transmitter Batteries.....	6
Transmitter Layout.....	7
Install the Flight Battery and Arm the Aircraft	8
Binding	8
Control Horn Locations and Surface Centering	9
Control Direction Test.....	10
Before Your First Flight.....	11
Transmitter Trims	12
Flying	12
Sensor Assisted Flight Envelope (SAFE) Flight Modes	13
SAFE System Calibration.....	15
Aerobatics Button	15
Repairs	16
Post Flight Checklist	16
Propeller Saver Instruction.....	16
Troubleshooting	17
Replacement Parts List	18
Limited Warranty	18
Warranty and Service Contact Information	19
FCC Information.....	20
IC Information	20

Specifications

Wingspan	17.7" (450mm)
Length	14.5" (368mm)
Weight*	Without Battery: 2.36oz (67g) With Recommended 1S 400mAh Flight Battery: 2.75oz (78g)

* The weight provided is for the aircraft and flight control components. No additional payload is allowed. MTOM is weight with recommended battery.

Included Equipment

Batteries (2)	3.7V 1S 400mAh Li-Po Battery (HBZ-1266)
Transmitter	HBZ-1267
Landing Gear Set	HBZ-1230
Propeller	HBZ-1231
USB-A Charger	HBZ-1268

Optional Accessories

RFL2000	RealFlight Trainer Edition Steam Download
SPMXC2050	S155 G2 1x55W AC Smart Charger
HBZ-2573	Charge Adapter: IC3 Battery / Molex 51005
SPMXC1040	S44 Micro 4-port AC/DC 1S LiPo Charger

Aircraft Components

Typical Control Components

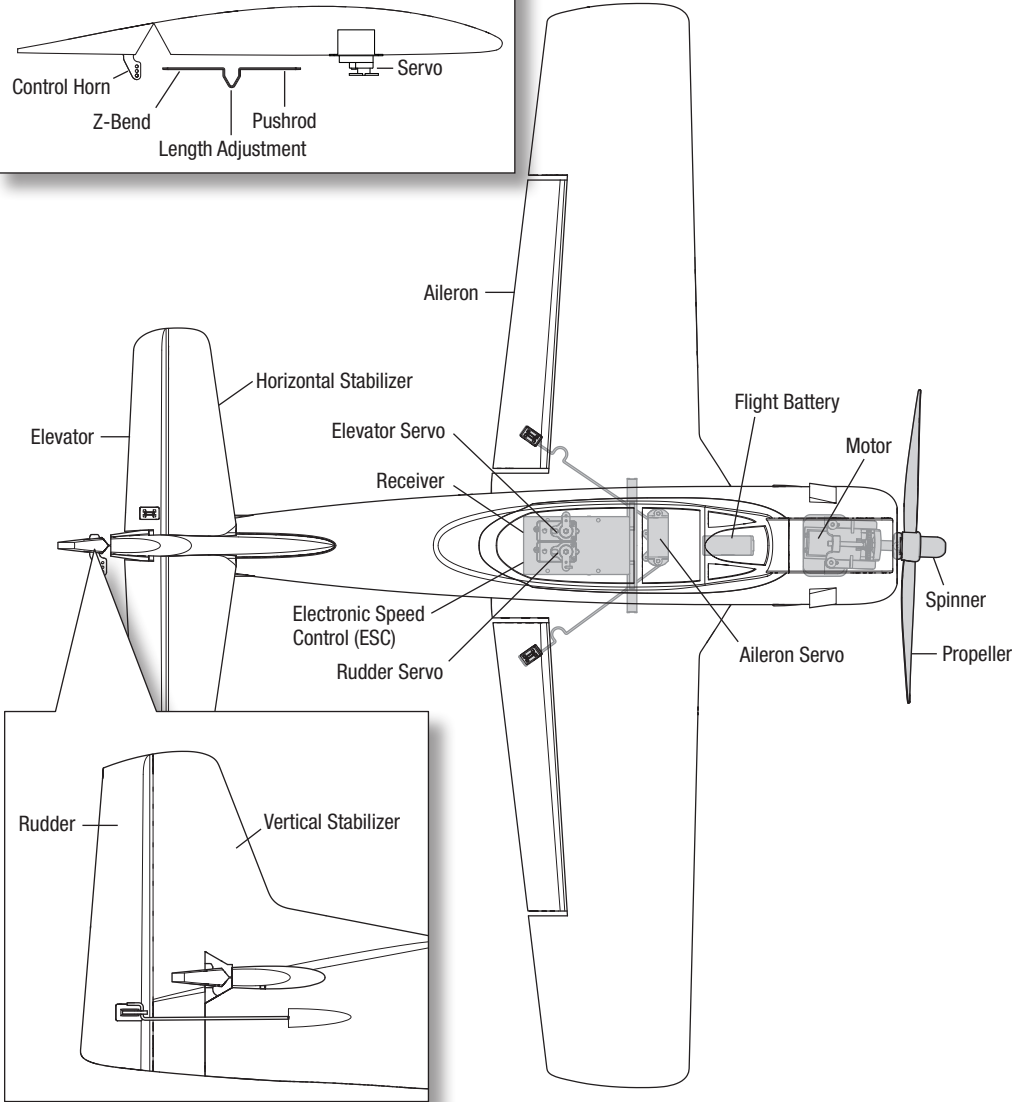
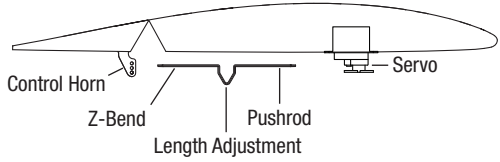

Preflight Checklist

Find a safe and open area.	Perform control direction test.
Charge the flight battery.	Plan flight for flying field conditions.
Install the transmitter batteries.	Set a flight timer for 7 minutes.
Install the flight battery.	Have fun!

Charging Warnings

The included USB charger has been designed to safely charge the included Li-Po battery.

CAUTION: All instructions and warnings must be followed exactly. Mishandling of Li-Po batteries can result in a fire, personal injury and/or property damage.

- **NEVER LEAVE CHARGING BATTERIES UNATTENDED.**
- **NEVER CHARGE BATTERIES OVERNIGHT.**
- By handling, charging or using the included Li-Po battery, you assume all risks associated with lithium batteries.
- If at any time the battery begins to balloon or swell, discontinue use immediately. If charging or discharging, discontinue and disconnect. Continuing to use, charge or discharge a battery that is ballooning or swelling can result in fire.
- Always store the battery at room temperature in a dry area for best results.
- Always transport or temporarily store the battery in a temperature range of 40–120° F. Do not store the battery or model in a car or direct sunlight. If stored in a hot car, the battery can be damaged or even catch fire.

- Always charge batteries away from flammable materials.
- Always inspect the battery before charging.
- Always disconnect the battery after charging, and let the charger cool between charges.
- Always constantly monitor the temperature of the battery pack while charging.
- **ONLY USE A CHARGER SPECIFICALLY DESIGNED TO CHARGE LI-PO BATTERIES.** Failure to charge the battery with a compatible charger may cause a fire resulting in personal injury and/or property damage.
- Never discharge Li-Po cells to below 3V under load.
- Never cover warning labels with hook and loop strips.
- Never leave charging batteries unattended.
- Never charge batteries outside recommended levels.
- Never charge damaged batteries.
- Never attempt to dismantle or alter the charger.
- Never allow minors to charge battery packs.
- Never charge batteries in extremely hot or cold places (recommended between 40–120° F or 5–49° C) or place in direct sunlight.

Charge the Flight Battery

CAUTION: Only use chargers specifically designed to charge the included Li-Po battery. Failure to do so could result in fire, causing injury or property damage.

CAUTION: Never exceed the recommended charge rate.

NOTICE: Charge only batteries that are cool to the touch and are not damaged. Look at the battery to make sure it is not damaged e.g., swollen, bent, broken or punctured.

1. Insert the charger into a USB port.
2. Connect the battery to the charger lead, noting the correct polarity.
3. Always disconnect the flight battery from the charger immediately upon completion of charging.

LED Indications

When you make the connection successfully, the LED on the charger turns solid red, indicating charging has begun. Charging a fully discharged (not over-discharged) 400mAh battery takes approximately 60 minutes. The LED changes to green when the charge is complete.

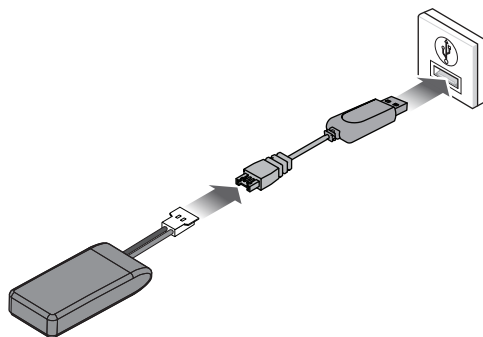

CHARGING (Solid Red)

CHARGE COMPLETE (Solid Green)

CAUTION: Once charging is complete, immediately remove the battery. Never leave a battery connected to the charger.

Assemble the Aircraft

1. Fully insert the left and right main landing gear (A) into the plastic mounts on the bottom of the wing.

IMPORTANT: The wheels should face toward the wingtips.

The landing gear is fully seated when it snaps into the mount.

2. Insert the nose gear (B) in the slot in the bottom of the fuselage, directly in front of the battery compartment.
3. Install the 1.7mm x 5mm nose gear retention screw (C) to secure the nose gear in place.

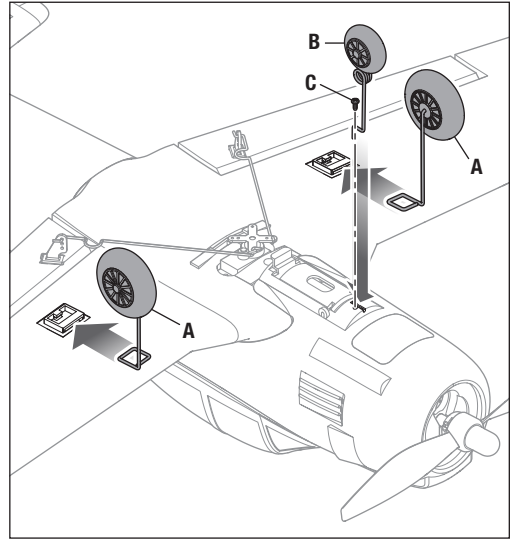

Install the Transmitter Batteries

1. Remove the screw securing the battery compartment cover using the provided Phillips-head screwdriver, and remove the battery hatch from the transmitter.
2. Install four included AA batteries (noting proper polarity).
3. Reinstall the battery cover.

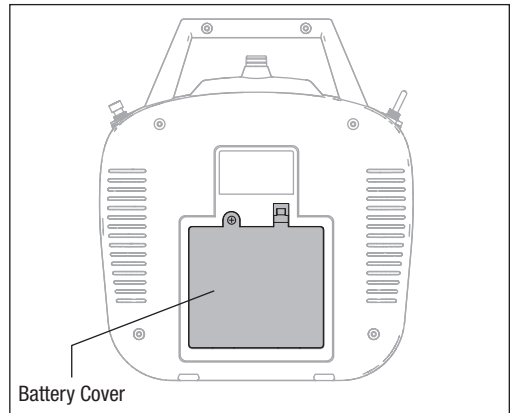

Transmitter Layout

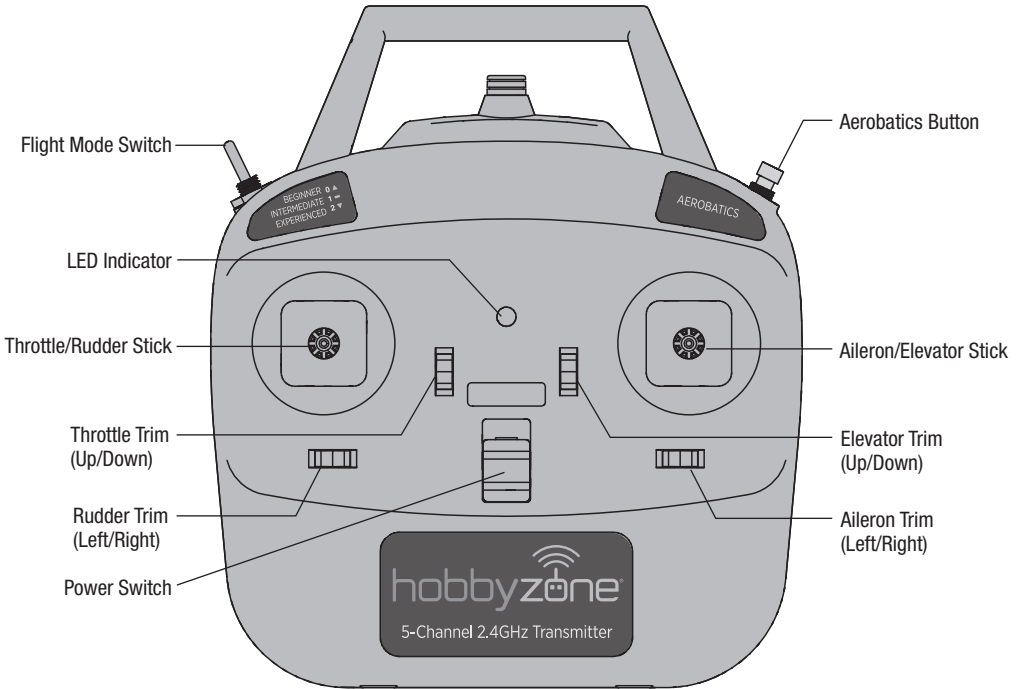

Install the Flight Battery and Arm the Aircraft

CAUTION: Always keep hands away from the propeller. When armed, the motor will turn the propeller in response to any throttle movement.

1. Ensure the transmitter throttle stick is in the lowest position. The motor will not arm if the throttle is not set to the lowest position when powering on the aircraft.
2. Power on the transmitter.
3. Release the latch and open the battery compartment cover.
4. Connect a fully charged flight battery to the power lead, then insert the battery in the battery compartment.
5. Close and latch the battery compartment cover.
6. Move the throttle stick to maximum and back to minimum to arm the ESC and enable motor operation.

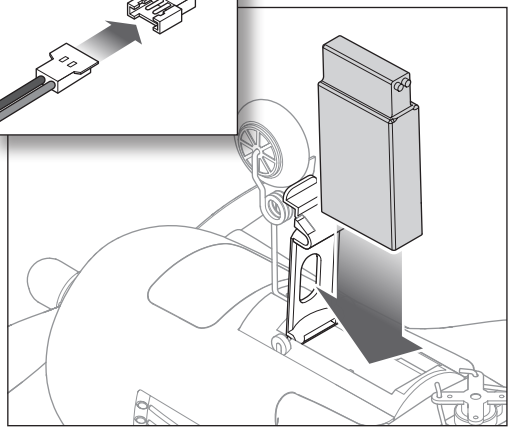
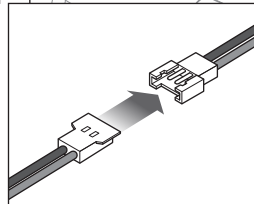
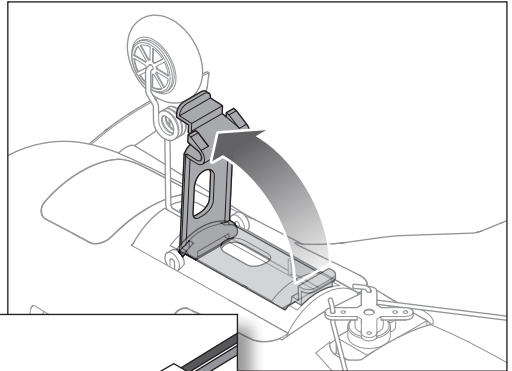

Binding

Binding is the process of programming the receiver to recognize the GUID (Globally Unique Identifier) code of a specific transmitter. The transmitter and receiver are bound at the factory. If you need to rebind, follow the instructions below.

1. Ensure the transmitter throttle stick is in the lowest position.
2. Ensure the flight mode switch is in Beginner or Intermediate mode.
3. Install and connect a fully charged flight battery to the aircraft and power ON the transmitter within 5 seconds.
4. After approximately 5 seconds, the LED on the aircraft flight control board will begin to flash rapidly.
5. When the LED on the aircraft's flight control board stops flashing, binding is complete.

CAUTION: Always keep hands away from the propeller. When armed, the motor will turn the propeller in response to any throttle movement.

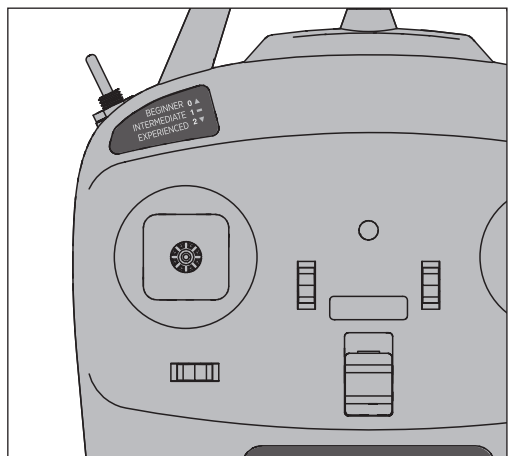

Control Horn Locations and Surface Centering

Control Horn Locations

The elevator, rudder, and aileron linkages should be connected to the center hole of the control horns, as shown in the illustrations.

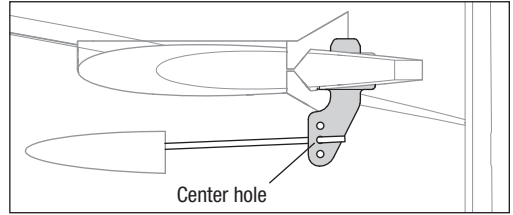

Elevator, viewed from the left

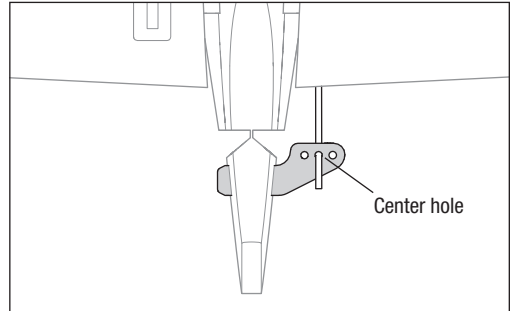

Rudder, viewed from below
(Some detail removed for clarity)

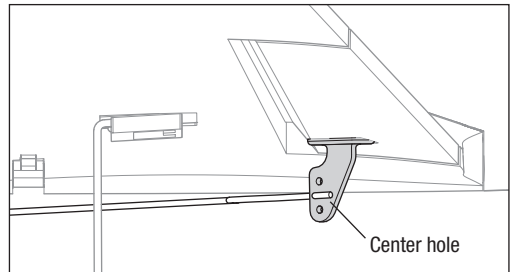

Aileron, viewed from the left

Surface Centering

Before the first flights, or in the event of an accident, make sure the flight control surfaces are centered.

Adjust the linkages mechanically if the control surfaces are not centered.

1. Make sure the control surfaces are neutral when the transmitter controls and trims are centered.
2. When needed, use a pair of pliers to carefully adjust the wire linkage (see illustration).
3. Make the U-shape narrower to make the linkage shorter. Make the U-shape wider to make the linkage longer.
4. Use care when adjusting the wire. Proceed slowly, as it is possible to break the wire if too much force is applied.

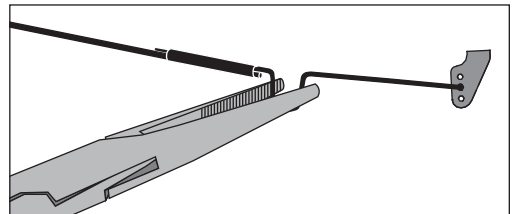

Control Direction Test

Test the controls prior to the first flight to ensure none of the servos, linkages or parts were damaged during shipping and handling and the controls function in the correct directions.

Ailerons

Move the aileron stick to the right. The right aileron should move up and the left aileron down. This will cause the aircraft to bank to the right in flight.

Move the aileron stick to the left. The left aileron should move up and the right aileron down. This will cause the aircraft to bank to the left in flight.

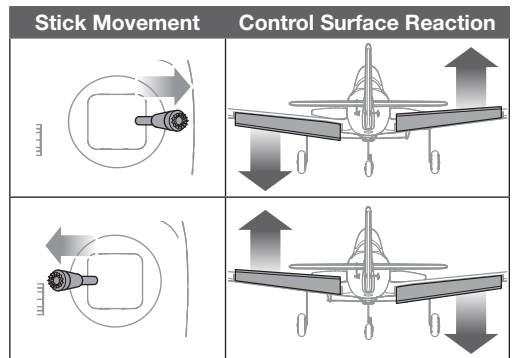

Elevator

Pull the elevator stick back. The elevator should move up. This will cause the nose of the aircraft to pitch up in flight.

Push the elevator stick forward. The elevator should move down. This will cause the nose of the aircraft to pitch down in flight.

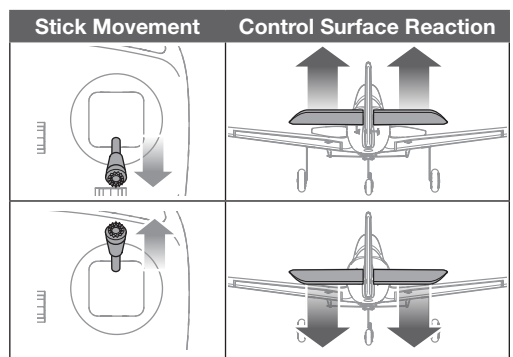

Rudder

Move the rudder stick to the right. The rudder should move to the right. This will cause the aircraft to yaw to the right in flight.

Move the rudder stick to the left. The rudder should move to the left. This will cause the aircraft to yaw to the left in flight.

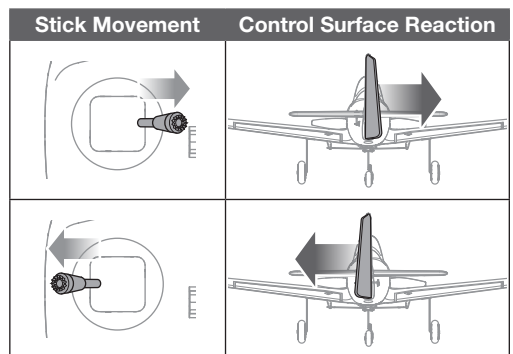

Before Your First Flight

Before attempting to fly this aircraft for the first time, we recommend using the RealFlight Trainer Edition RC Flight Simulator (RFL1205, not included), to learn and practice the basics of flying. A Spektrum transmitter may be connected to a PC for simulator use with a standard USB-C cable. Featuring six popular Horizon Hobby trainer aircraft and built-in Virtual Flight Instructor lessons, new pilots can learn to fly successfully by practicing on a PC at home or on a laptop just about anywhere else!

We also encourage you to connect with experienced RC pilots in your area through hobby shops or at designated flying fields. For those located in the United States, we recommend joining a national organization such as the Academy of Model Aeronautics (AMA). The AMA can provide information on local clubs, instructors and established flying sites in your area in addition to insurance coverage. Visit www.modelaircraft.org for more information.



RealFlight
Trainer Edition



Transmitter Trims

The included transmitter features digital trim buttons next to the control sticks to make fine adjustments during flight. The transmitter beeps when a trim button is pressed. The tone changes slightly when the trim value is centered.

To quickly re-center the trims, press both the left and right sticks at the same time.

If the aircraft drifts right or left in flight, use the opposite direction aileron trim button correct the drift. For example, if the aircraft drifts right in flight, press and release the left aileron trim button until the aircraft no longer drifts.

If the aircraft climbs or dives during flight, press and release the down or up trim buttons until the aircraft flies level.

If there is not enough digital trim available, mechanically adjust the control linkages to adjust the surfaces.

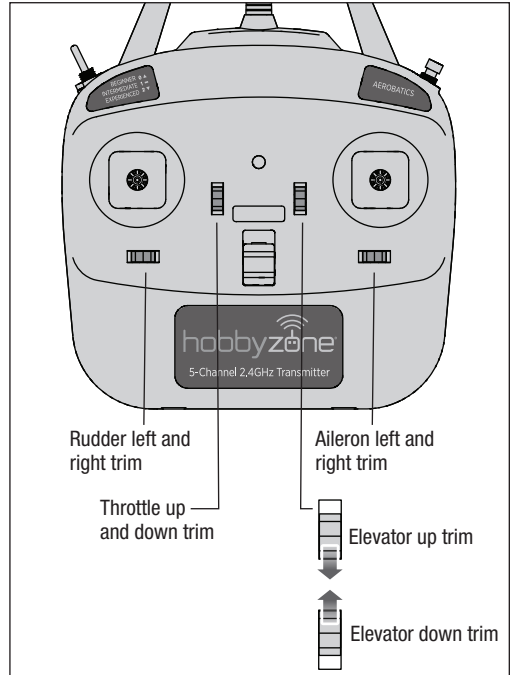

Flying

Consult local laws and ordinances before choosing a location to fly your aircraft.

We recommend flying your aircraft outside in no greater than light winds (5mph or below). Always avoid flying near houses, trees, wires and buildings.

Avoid flying in areas where there are many people, such as busy parks, schoolyards or soccer fields.

TIP: This aircraft can normally fly 6-8 minutes on a fully charged flight battery. This time will vary depending on your flying style, flight conditions and the condition of your battery.

Hand Launching

To hand launch the aircraft, place the aircraft in Beginner mode (only/always), and grip the fuselage immediately behind the wing. Advance to full throttle and give the aircraft a firm throw, slightly up (5–10 degrees above the horizon), and directly into the wind. After the model gains altitude and speed, decrease the throttle as you desire.

Takeoff

Taxi the aircraft in position for takeoff facing into the wind. Gradually increase the throttle to full power. Hold a small amount of up elevator and steer with the rudder.

When the aircraft lifts off, climb gently and adjust the trim for level flight. Once the trim is adjusted, begin exploring the flight envelope of the aircraft.

Landing

Always land into the wind. Use throttle management to control the descent rate of the aircraft.

During flare, keep the wings level and the aircraft pointed into the wind. Slowly lower the throttle while easing back on the elevator to bring the aircraft gently down on the main wheels.

NOTICE: Always fully lower the throttle at touch down when landing the aircraft. Failure to lower the throttle stick and trim to the lowest possible positions during a crash could result in damage to the ESC in the receiver unit.

Crash damage is not covered under warranty. Repair this aircraft using CA glue or clear tape.

NOTICE: Use of CA accelerant on your aircraft can damage paint. DO NOT handle the aircraft until adhesive fully dries.

Sensor Assisted Flight Envelope (SAFE) Flight Modes

You control how much help SAFE® technology provides while you learn to fly. As your flying skills grow, decrease SAFE technology assistance. Change aircraft response at any time by moving the Channel 5 (SAFE flight mode) switch on your transmitter.

IMPORTANT: These instructions are for the included transmitter.

SAFE Flight Modes	Flight Mode Switch
Beginner Mode	Position 0
Intermediate Mode	Position 1
Experienced Mode	Position 2

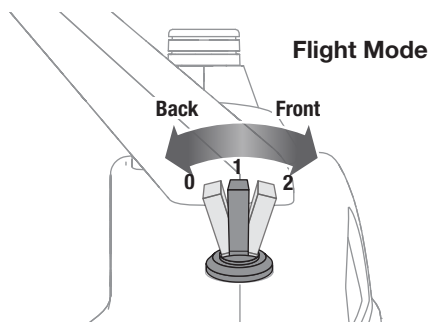

If you get into distress while flying in Intermediate or Experienced mode (0), flip the switch to Beginner SAFE technology will return the aircraft to a stable attitude, if the aircraft is at a sufficient height with no obstacles in its path.

Activating SAFE Technology

Once the SAFE technology is active, the control surfaces may move on the aircraft. This is normal. The SAFE technology will remain active until the battery is disconnected.

Launch and Landing Assistance

Take off and landings can be better managed by using Beginner mode. If the model is launched incorrectly, or is landing at a less than perfect attitude, switch to Beginner mode. The model can correct and help to prevent a crash. See the Take Off and Landing sections in this manual.

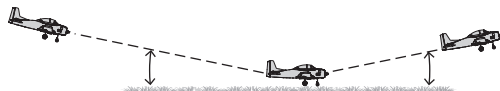

SAFE Technology makes this aircraft a better learning tool, but you must set yourself up for success in flying:

- SAFE technology is designed as flight assistance, not an autopilot. The pilot is always in control and required to fly the aircraft at all times
- Follow the instructions provided in this manual to maintain your aircraft in top flying condition
- Seek qualified model flying instruction through your local model flying club. A qualified flight instructor can propel your advancement in this hobby
- Wind and environment can affect SAFE technology flight performance
- Ensure you have no distractions so you benefit from every moment of flight time
- You must still fly the aircraft away from obstacles and at an altitude that will allow for a safe recovery

SAFE technology is a revolutionary flight training system designed to give you a stable platform for safely developing your flying skills. This is not an autopilot or self-guiding system. The sensors and software in this system help you fly the aircraft where you want to go while decreasing the risk of an out-of-control crash. You can progress through the Beginner, Intermediate and Experienced flight modes as your skills increase. At any time during a flight you can switch between the 3 flight modes to explore the different flight attitudes. If you lose control while flying in Intermediate or Experienced mode switch to Beginner mode to return your aircraft to a safe flying attitude.

SAFE Flight Modes

Beginner Mode

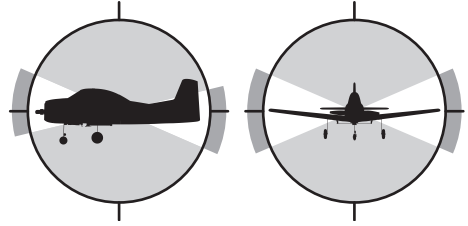

- Envelope limit: Pitch (nose up and down) and Roll (wing tips up and down) angles are limited to help you keep the aircraft airborne.
- Self-leveling: when the pitch and roll controls are returned to neutral, the aircraft returns to level flight.
- Stability assisted takeoff and landing.
- Throttle based climb and descent.

Intermediate Mode

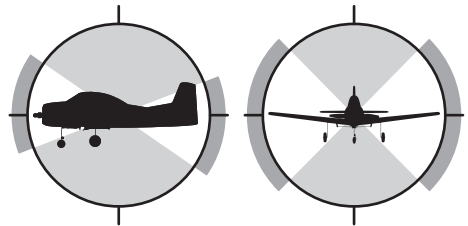

- Natural Flight Experience: Pitch and roll controls are increased. Self leveling is still active, but slower than in Beginner mode.
- Larger Flight Envelope: Greater flight attitudes are possible.

Experienced Mode

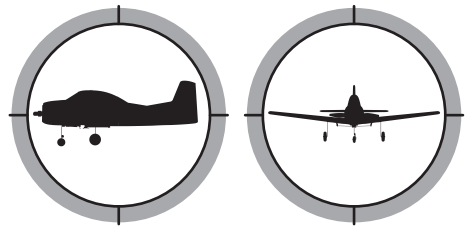

- Natural Flight Experience: The pilot experiences natural flight for smooth handling and outstanding precision.
- Unlimited Flight Envelope: No limit on pitch and roll angles.

SAFE System Calibration

1. Place the aircraft on a flat horizontal surface.
2. Lower the throttle stick completely.
3. Power ON the transmitter, then connect the flight battery to the aircraft.
4. Do not move the throttle.
5. Move and hold the transmitter sticks to the position shown in the image until the transmitter beeps.

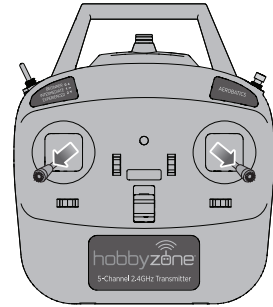

Aerobatics Button

The Aerobatics button activates aerobatic mode in the aircraft. While in flight, press the aerobatics button, the transmitter will beep several times. During the beeping, move the aileron stick left or right to make the aircraft roll. Or move the elevator stick up or down to make the aircraft loop.

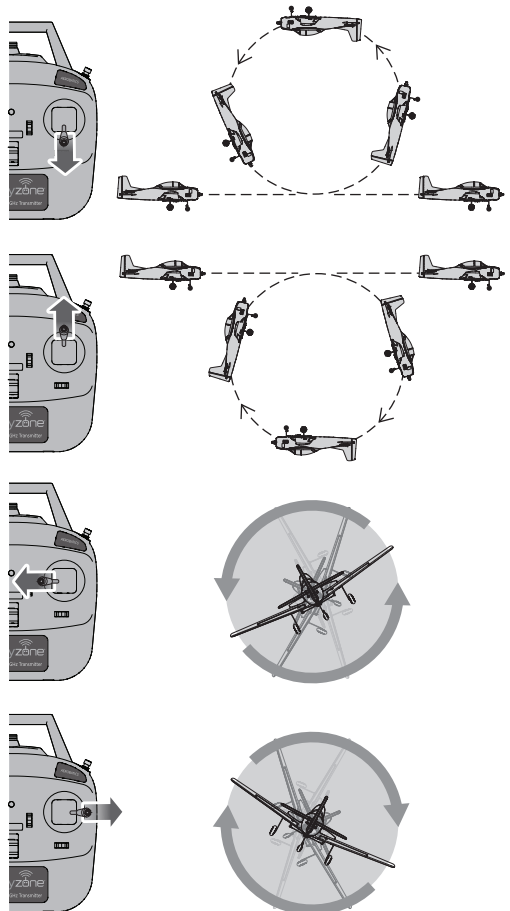

Repairs

Repair this aircraft using CA glue or clear tape.

NOTICE: Use of CA accelerant on your aircraft can damage paint. DO NOT handle the aircraft until adhesive fully dries.

Post Flight Checklist

Disconnect the flight battery.

Power OFF the transmitter.

Remove the flight battery from the aircraft.
--

Recharge the flight battery.

Repair or replace all damaged parts.

Store the flight battery apart from the aircraft and monitor the battery charge.
--

Make note of the flight conditions and flight plan results, planning for future flights.
--

Propeller Saver Instruction

The propeller saver keeps the propeller from damage, and prevents the electronic components from current overloads. The propeller assembly will break loose when it contacts the ground or object. To replace the propeller, align the hub pieces and press the propeller into place until a click is felt.

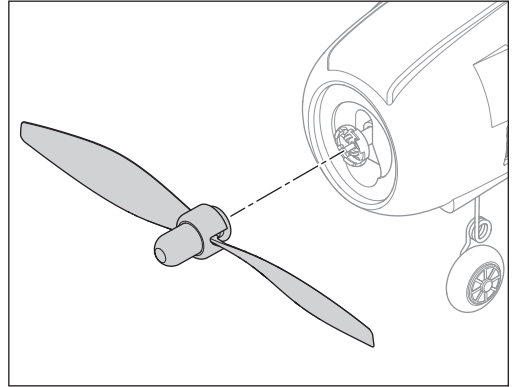

Troubleshooting

Problem	Possible Cause	Solution
Aircraft will not respond to throttle but responds to other controls	Throttle stick and/or throttle trim is too high	Reset controls with throttle stick and throttle trim at lowest setting
	Motor is disconnected from receiver	Open fuselage and ensure the plug for the motor is properly installed
Extra propeller noise or extra vibration	Damaged propeller, prop shaft or motor	Replace damaged parts
Reduced flight time or aircraft underpowered	Flight battery charge is low	Completely recharge flight battery
	Flight battery is damaged	Replace flight battery and follow flight battery instructions
	Flight conditions may be too cold	Make sure battery is warm before use
	Battery capacity is too low for flight conditions	Replace battery or use a larger capacity battery
LED on receiver flashes rapidly and aircraft will not bind to transmitter (during binding)	Transmitter is too near aircraft during binding process	Power off transmitter, move transmitter a larger distance from aircraft, disconnect and reconnect flight battery to aircraft and follow binding instructions
	Bind button was not held while transmitter was powered on	Power off transmitter and repeat bind process
	Aircraft or transmitter is too close to large metal object, wireless source or another transmitter	Move aircraft and transmitter to another location and attempt binding again
LED on receiver flashes rapidly and aircraft will not respond to transmitter (after binding)	Less than a 5-second wait between first powering on transmitter and connecting flight battery to aircraft	Leaving transmitter on, disconnect and reconnect flight battery to aircraft
	Flight battery/transmitter battery charge is too low	Replace/recharge batteries
	Transmitter may have been bound to a different model	Select the right transmitter or bind to the new one
	Aircraft or transmitter is too close to large metal object, wireless source or another transmitter	Move aircraft and transmitter to another location and attempt connecting again
Control surface does not move	Control surface, control horn, linkage or servo damage	Replace or repair damaged parts and adjust controls
	Wire damaged or connections loose	Do a check of wires and connections; connect or replace as needed
	Flight battery charge is low	Fully recharge flight battery
	Control linkage does not move freely	Make sure control linkage moves freely
Motor loses power	Damage to motor or power components	Check the motor and power components for damage (replace as needed)
Motor power pulses then loss of power	Battery power is down to the point of receiver/ ESC Low Voltage Cutoff (LVC)	Recharge flight battery or replace battery that is no longer performing

Replacement Parts List

Part Number	Description
HBZ-1266	3.7V 1S 400mAh LiPo Battery; Molex 51005
HBZ-1267	Transmitter
HBZ-1268	USB-A Charger; Molex 51006
HBZ-1275	Propeller Adapter Set (3)
HBZ-1229	Replacement Airframe
HBZ-1231	Propeller and Spinner
HBZ-1230	Landing Gear Set

Limited Warranty

What this Warranty Covers

Horizon Hobby, LLC, (Horizon) warrants to the original purchaser that the product purchased (the "Product") will be free from defects in materials and workmanship at the date of purchase.

What is Not Covered

This warranty is not transferable and does not cover (i) cosmetic damage, (ii) damage due to acts of God, accident, misuse, abuse, negligence, commercial use, or due to improper use, installation, operation or maintenance, (iii) modification of or to any part of the Product, (iv) attempted service by anyone other than a Horizon Hobby authorized service center, (v) Product not purchased from an authorized Horizon dealer, (vi) Product not compliant with applicable technical regulations, or (vii) use that violates any applicable laws, rules, or regulations. OTHER THAN THE EXPRESS WARRANTY ABOVE, HORIZON MAKES NO OTHER WARRANTY OR REPRESENTATION, AND HEREBY DISCLAIMS ANY AND ALL IMPLIED WARRANTIES, INCLUDING, WITHOUT LIMITATION, THE IMPLIED WARRANTIES OF NON-INFRINGEMENT, MERCHANTABILITY AND FITNESS FOR A PARTICULAR PURPOSE. THE PURCHASER ACKNOWLEDGES THAT THEY ALONE HAVE DETERMINED THAT THE PRODUCT WILL SUITABLY MEET THE REQUIREMENTS OF THE PURCHASER'S INTENDED USE.

Purchaser's Remedy

Horizon's sole obligation and purchaser's sole and exclusive remedy shall be that Horizon will, at its option, either (i) service, or (ii) replace, any Product determined by Horizon to be defective. Horizon reserves the right to inspect any and all Product(s) involved in a warranty claim. Service or replacement decisions are at the sole discretion of Horizon. Proof of purchase is required for all warranty claims. SERVICE OR REPLACEMENT AS PROVIDED UNDER THIS WARRANTY IS THE PURCHASER'S SOLE AND EXCLUSIVE REMEDY.

Limitation of Liability

HORIZON SHALL NOT BE LIABLE FOR SPECIAL, INDIRECT, INCIDENTAL OR CONSEQUENTIAL DAMAGES, LOSS OF PROFITS OR PRODUCTION OR COMMERCIAL LOSS IN ANY WAY, REGARDLESS OF WHETHER SUCH CLAIM IS BASED IN CONTRACT, WARRANTY, TORT, NEGLIGENCE, STRICT LIABILITY OR ANY OTHER THEORY OF LIABILITY, EVEN IF HORIZON HAS BEEN ADVISED OF THE POSSIBILITY OF SUCH DAMAGES.

Further, in no event shall the liability of Horizon exceed the individual price of the Product on which liability is asserted. As Horizon has no control over use, setup, final assembly, modification or misuse, no liability shall be assumed nor accepted for any resulting damage or injury. By the act of use, setup or assembly, the user accepts all resulting liability. If you as the purchaser or user are not prepared to accept the liability associated with the use of the Product, purchaser is advised to return the Product immediately in new and unused condition to the place of purchase.

Law

These terms are governed by Illinois law (without regard to conflict of law principals). This warranty gives you specific legal rights, and you may also have other rights which vary from state to state. Horizon reserves the right to change or modify this warranty at any time without notice.

WARRANTY SERVICES

Questions, Assistance, and Services

Your local hobby store and/or place of purchase cannot provide warranty support or service. Once assembly, setup or use of the Product has been started, you must contact your local distributor or Horizon directly. This will enable Horizon to better answer your questions and service you in the event that you may need any assistance. For questions or assistance, please visit our website at www.horizonhobby.com, submit a Product Support Inquiry, or call the toll free telephone number referenced in the Warranty and Service Contact Information section to speak with a Product Support representative.

Inspection or Services

If this Product needs to be inspected or serviced and is compliant in the country you live and use the Product in, please use the Horizon Online Service Request submission process found on our website or call Horizon to obtain a Return Merchandise Authorization (RMA) number. Pack the Product securely using a shipping carton. Please note that original boxes may be included, but are not designed to withstand the rigors of shipping without additional protection. Ship via a carrier that provides tracking and insurance for lost or damaged parcels, as Horizon is not responsible for merchandise until it arrives and is accepted at our facility. An Online Service Request is available at <http://www.horizonhobby.com>.

horizonhobby.com/content/service-center_render-service-center. If you do not have internet access, please contact Horizon Product Support to obtain a RMA number along with instructions for submitting your product for service. When calling Horizon, you will be asked to provide your complete name, street address, email address and phone number where you can be reached during business hours. When sending product into Horizon, please include your RMA number, a list of the included items, and a brief summary of the problem. A copy of your original sales receipt must be included for warranty consideration. Be sure your name, address, and RMA number are clearly written on the outside of the shipping carton.

NOTICE: Do not ship LiPo batteries to Horizon. If you have any issue with a LiPo battery, please contact the appropriate Horizon Product Support office.

Warranty Requirements

For Warranty consideration, you must include your original sales receipt verifying the proof-of-purchase date. Provided warranty conditions have been met, your Product will be serviced or replaced free of charge. Service or replacement decisions are at the sole discretion of Horizon.

Non-Warranty Service

Should your service not be covered by warranty, service will be completed and payment will be required without notification or estimate of the expense unless the expense exceeds 50% of the retail purchase cost. By submitting the item for service you are agreeing to payment of the service without notification. Service estimates are available upon request. You must include this request with your item submitted for service. Non-warranty service estimates will be billed a minimum of ½ hour of labor. In addition you will be billed for return freight. Horizon accepts money orders and cashier's checks, as well as Visa, MasterCard, American Express, and Discover cards. By submitting any item to Horizon for service, you are agreeing to Horizon's Terms and Conditions found on our website http://www.horizonhobby.com/content/service-center_render-service-center.

ATTENTION: Horizon service is limited to Product compliant in the country of use and ownership. If received, a non-compliant Product will not be serviced. Further, the sender will be responsible for arranging return shipment of the un-serviced Product, through a carrier of the sender's choice and at the sender's expense. Horizon will hold non-compliant Product for a period of 60 days from notification, after which it will be discarded.

10/15

Warranty and Service Contact Information

Country of Purchase	Horizon Hobby	Contact Information	Address
United States of America	Horizon Service Center (Repairs and Repair Requests)	servicecenter.horizonhobby.com/RequestForm/	2904 Research Rd Champaign, IL 61822
	Horizon Product Support (Product Technical Assistance)	productsupport@horizonhobby.com 877-504-0233	
	Sales	websales@horizonhobby.com 800-338-4639	
European Union	Horizon Technischer Service	service@horizonhobby.eu	Hanskampring 9 D 22885 Barsbüttel, Germany
	Sales: Horizon Hobby GmbH	+49 (0) 4121 2655 100	

FCC Information

FCC ID: 2A8F5-MODELAIRPLANE

This equipment has been tested and found to comply with the limits for a Class B digital device, pursuant to part 15 of the FCC Rules. These limits are designed to provide reasonable protection against harmful interference in a residential installation. This equipment generates, uses and can radiate radio frequency energy and, if not installed and used in accordance with the instructions, may cause harmful interference to radio communications.

NOTICE: Modifications to this product will void the user's authority to operate this equipment.

This product contains a radio transmitter with wireless technology which has been tested and found to be compliant with the applicable regulations governing a radio transmitter in the 2.400GHz to 2.4835GHz frequency range.

Supplier's Declaration of Conformity

HBZ Trojan 450mm (HBZ-1228)

 This device complies with part 15 of the FCC Rules. Operation is subject to the following two conditions:
 (1) This device may not cause harmful interference, and (2) this device must accept any interference received, including interference that may cause undesired operation.

 **CAUTION:** Changes or modifications not expressly approved by the party responsible for compliance could void the user's authority to operate the equipment.

NOTE: This equipment has been tested and found to comply with the limits for a Class B digital device, pursuant to part 15 of the FCC Rules. These limits are designed to provide reasonable protection against harmful interference in a residential installation. This equipment generates, uses and can radiate radio frequency energy and, if not installed and used in accordance with the instructions, may cause harmful interference to radio communications. However, there is no guarantee that interference will not occur in a particular installation. If this equipment does cause harmful interference to radio or television reception, which can be determined by turning the equipment off and on, the user is encouraged to try to correct the interference by one or more of the following measures:

- Reorient or relocate the receiving antenna.
- Increase the separation between the equipment and receiver.
- Connect the equipment into an outlet on a circuit different from that to which the receiver is connected.
- Consult the dealer or an experienced radio/TV technician for help.

Horizon Hobby, LLC

2904 Research Rd.,
Champaign, IL 61822

Email: compliance@horizonhobby.com

Web: HorizonHobby.com

IC Information

IC: 6157A-HBZ1267

CAN ICES-3 (B)/NMB-3(B)

This device complies with Industry Canada license-exempt RSS standard(s). Operation is subject to the following two conditions:

(1) this device may not cause interference, and (2) this device must accept any interference, including interference that may cause undesired operation of the device.



© 2026 Horizon Hobby, LLC

HobbyZone, the HobbyZone logo, and the Horizon Hobby logo are trademarks
or registered trademarks of Horizon Hobby, LLC. www.horizonhobby.com

Modified 01/26

HBZ-1228

1299020