

Beechcraft D18 1.5m

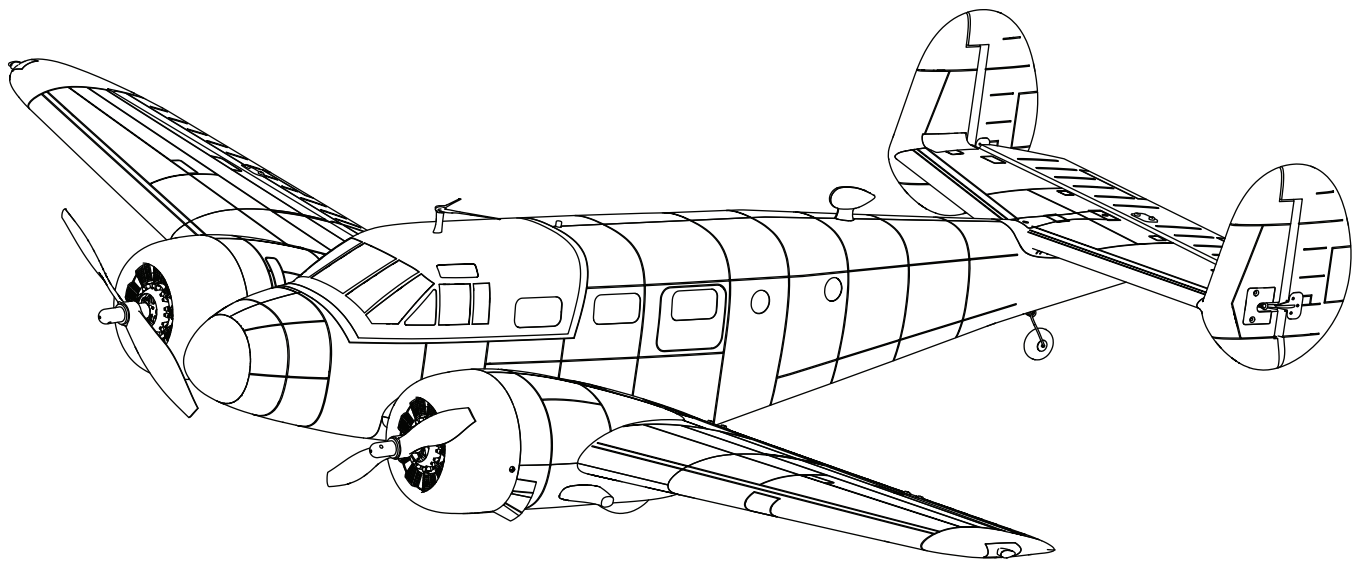

Scan the QR code and select the Manuals and Support quick links from the product page for the most up-to-date manual information.

Scannen Sie den QR-Code und wählen Sie auf der Produktseite die Quicklinks Handbücher und Unterstützung, um die aktuellsten Informationen zu Handbücher.

Scannez le code QR et sélectionnez les liens rapides Manuals and Support sur la page du produit pour obtenir les informations les plus récentes sur le manuel.

Scannerizzare il codice QR e selezionare i Link veloci Manuali e Supporto dalla pagina del prodotto per le informazioni manuali più aggiornate.



EFL106250



EFL106275

Instruction Manual
Bedienungsanleitung
Manuel d'utilisation
Manuale di Istruzioni

NOTICE

All instructions, warranties and other collateral documents are subject to change at the sole discretion of Horizon Hobby, LLC. For up-to-date product literature, visit horizonhobby.com or towerhobbies.com and click on the support or resources tab for this product.

MEANING OF SPECIAL LANGUAGE

The following terms are used throughout the product literature to indicate various levels of potential harm when operating this product:

WARNING: Procedures, which if not properly followed, create the probability of property damage, collateral damage, and serious injury OR create a high probability of superficial injury.

CAUTION: Procedures, which if not properly followed, create the probability of physical property damage AND a possibility of serious injury.

NOTICE: Procedures, which if not properly followed, create a possibility of physical property damage AND little or no possibility of injury.



WARNING: Read the ENTIRE instruction manual to become familiar with the features of the product before operating. Failure to operate the product correctly can result in damage to the product, personal property and cause serious injury.

This is a sophisticated hobby product. It must be operated with caution and common sense and requires some basic mechanical ability. Failure to operate this Product in a safe and responsible manner could result in injury or damage to the product or other property. This product is not intended for use by children without direct adult supervision. Do not use with incompatible components or alter this product in any way outside of the instructions provided by Horizon Hobby, LLC. This manual contains instructions for safety, operation and maintenance. It is essential to read and follow all the instructions and warnings in the manual, prior to assembly, setup or use, in order to operate correctly and avoid damage or serious injury.

AGE RECOMMENDATION: Not for children under 14 years. This is not a toy.

Safety Precautions and Warnings

As the user of this product, you are solely responsible for operating in a manner that does not endanger yourself and others or result in damage to the product or the property of others.

- Always keep a safe distance in all directions around your model to avoid collisions or injury. This model is controlled by a radio signal subject to interference from many sources outside your control. Interference can cause momentary loss of control.
- Always operate your model in open spaces away from full-size vehicles, traffic and people.
- Always carefully follow the directions and warnings for this and any optional support equipment (chargers, rechargeable battery packs, etc.).
- Always keep all chemicals, small parts and anything electrical out of the reach of children.
- Always avoid water exposure to all equipment not specifically designed and protected for this purpose. Moisture causes damage to electronics.
- Never place any portion of the model in your mouth as it could cause serious injury or even death.
- Never operate your model with low transmitter batteries.
- Always keep aircraft in sight and under control.
- Always use fully charged batteries.
- Always keep transmitter powered on while aircraft is powered.
- Always remove batteries before disassembly.
- Always keep moving parts clean.
- Always keep parts dry.
- Always let parts cool after use before touching.
- Always remove batteries after use.
- Always ensure failsafe is properly set before flying.
- Never operate aircraft with damaged wiring.
- Never touch moving parts.



WARNING AGAINST COUNTERFEIT PRODUCTS: If you ever need to replace your Spektrum receiver found in a Horizon Hobby product, always purchase from Horizon Hobby, LLC or a Horizon Hobby authorized dealer to ensure authentic high-quality Spektrum product. Horizon Hobby, LLC disclaims all support and warranty with regards, but not limited to, compatibility and performance of counterfeit products or products claiming compatibility with DSM or Spektrum technology.

Included / Recommended Equipment

	BNF BASIC	PNP PLUG-N-PLAY
Motors: (2) 3226 Outrunner Motor, 930Kv, 14 pole (SPMXAM1700B)	Included	Included
ESC: Avian Dual 40 Amp Brushless ESC 3-4S (SPMXAE0240A)	Installed	Installed
Servos: 14g Sub-Micro servo: 140mm Lead (SPMSA382) Aileron: (2) Rudder: (1) Elevator: (1) Flaps: (2)	Installed	Installed
Receiver: Spektrum™ AR631 6-Channel AS3X/SAFE Telemetry Receiver (SPMAR631)	Installed	Required
Recommended Battery: 4S 4000mAh LiPo	Required	Required
Recommended Battery Charger: 3-4-cell Li-Po battery balancing charger	Required	Required
Recommended Transmitter: Full range 6-channel 2.4GHz with Spektrum DSMX®/DSM2 technology with adjustable Dual Rates.	Required	Required

Specifications

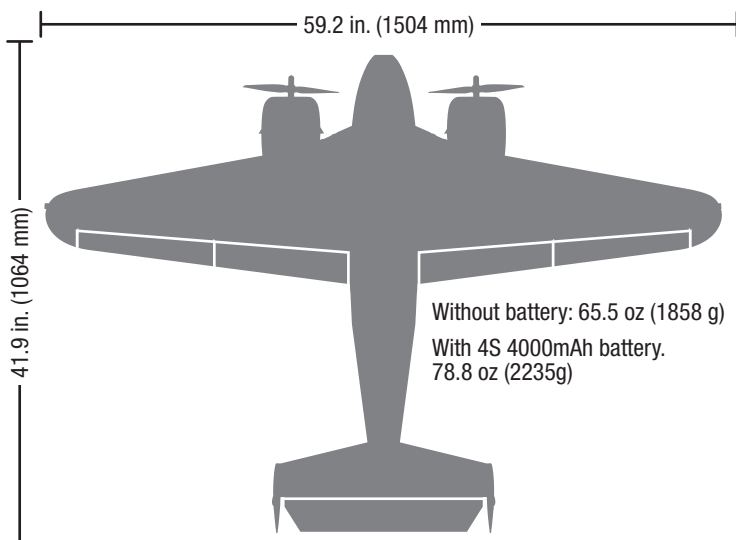

If you own this product, you may be required to register with the FAA. For up-to-date information on how to register with the FAA, please visit <https://registermyuas.faa.gov/>. For additional assistance on regulations and guidance on UAS usage, visit knowbeforeyoufly.org/.

Table of Contents

Specifications	3	Servo Service	16
Model Assembly	4	Troubleshooting Guide AS3X	17
Transmitter Setup	6	Troubleshooting Guide	17
Differential Thrust	7	Troubleshooting Guide Continued	18
PNP Receiver Selection and Installation	7	Replacement Parts	18
Battery Installation and ESC Arming	8	Important Federal Aviation Administration (FAA) Information	18
Binding	9	Recommended Items	18
SAFE® Select Switch Designation <i>BNF</i>	10	Optional Parts	18
Integrated ESC Telemetry	10	AMA National Model Aircraft Safety Code	19
Control Direction Test	11	Limited Warranty	19
AS3X Response Test	12	Contact Information	20
Control Surface Centering and Adjusting a Clevis	12	FCC Information	20
Control Horn and Servo Arm Factory Settings	13	IC Information	20
Dual Rates and Control Throws	13	Compliance Information for the European Union	20
Center of Gravity (CG)	14		
SAFE Select Flying Tips <i>BNF</i>	14		
In-Flight Trimming	15		
Post Flight	15		
Thrust Reversing (<i>Optional</i>)	15		
Motor Service	16		

Model Assembly

WARNING: Do not perform this or any other equipment test without turning on throttle cut. Serious injury or property damage could result from the motor starting inadvertently.

Wing Installation

1. Align and insert the wing into the opening in the bottom of the fuselage.
2. Secure the wing into position using the included 4 screws (M3x10mm) (A) using a Phillips screwdriver..
3. Insert a wing tube (B) into each wing tip (C).
4. Align the wing tip with the wing and press them together until they click. Simply pull them OFF the center wing panel to remove.

Disassemble in reverse order.

Tip: Rocking the wing tip fore and aft slightly will more easily disengage the wing tip retainers.

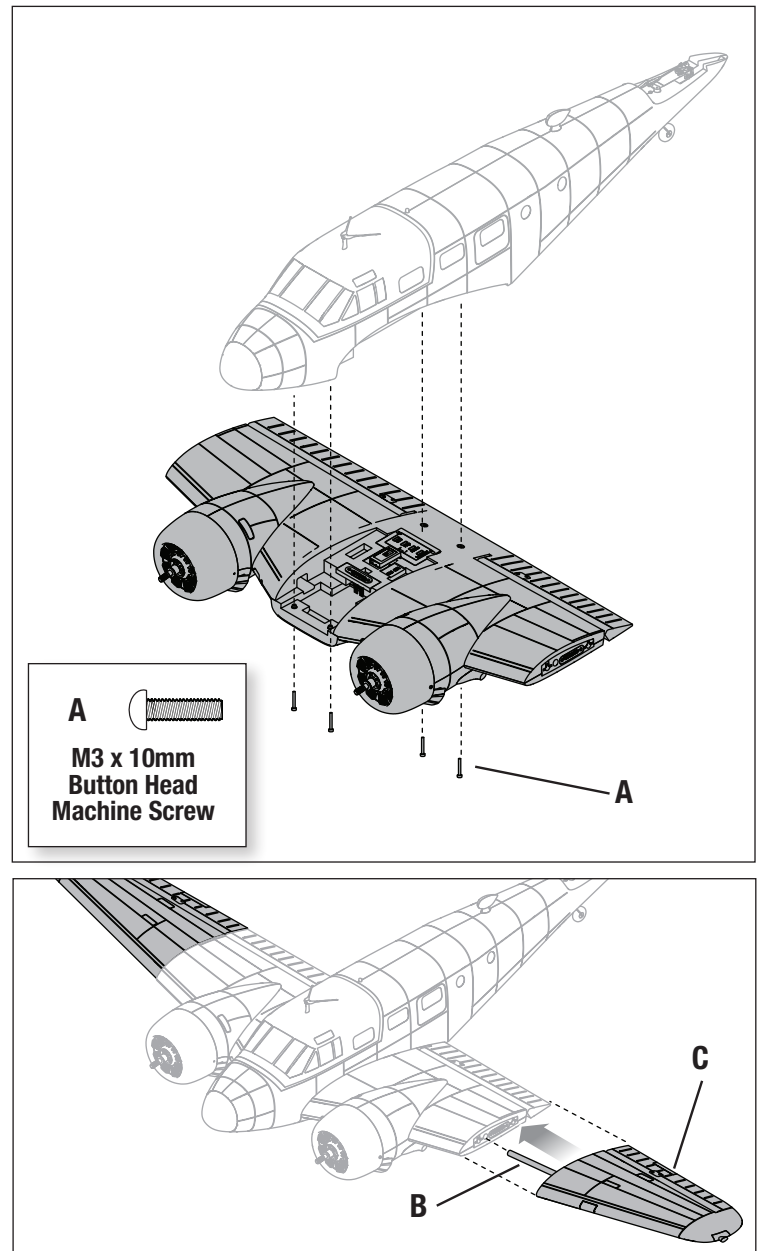

Tail Installation

1. Connect the clevis on the elevator pushrod to the outermost hole on the elevator control horn (A), and slide the retaining tube over the clevis.
2. Align the tail section with the fuselage and insert the drive pin (B) from the rudder pushrod into the slot in the bellcrank (C).
3. Secure the tail section into position using the included 2 screws (2.6 x10mm self tapping) (D) using a Phillips screwdriver.

Disassemble in reverse order.

After the tail is installed, ensure the rudder pin is secured in the bellcrank by attempting to move the rudders. There should be resistance if tried to move left or right. If the rudder can be moved freely in one direction, but not the other, the pin is likely not engaged in the rudder bellcrank. Remove the tail section and ensure the pin is correctly engaged.

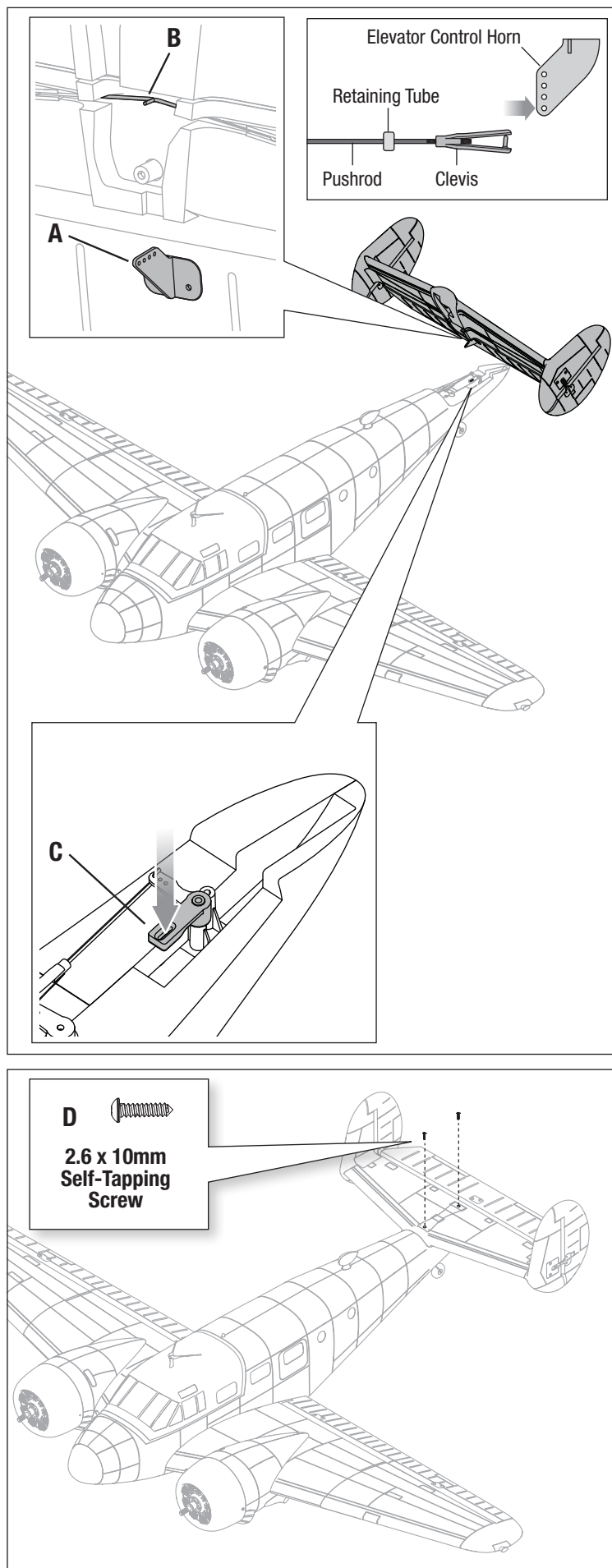

Transmitter Setup



WARNING: Enable the throttle cut feature. Always engage throttle cut before approaching the aircraft.



WARNING: Never assign Aux 2 to SAFE Select during transmitter setup with any model transmitter. If SAFE Select is assigned to Aux 2, the throttle channel/motor will reverse in flight once SAFE is enabled. Motor reversing is assigned to Aux 2/channel 7 by default in the Smart ESC.

IMPORTANT: After you set up your model, always rebind the transmitter and receiver to set the desired failsafe positions.

IMPORTANT: The included receiver has been programmed specifically for operation in this aircraft.

The GEAR Channel (CH 5) controls the retractable landing gear.
The FLAP Channel (CH 6) controls the flaps.

‡ For DX6e, DX6, and DX7 setups, The FLAP Channel (CH 6) can be used to toggle SAFE Select. With the values listed in the radio setup table, it will turn SAFE ON for half and full flap positions and AS3X will be ON for no flaps position. To use the flap channel for SAFE Select, the switch values must be set to +100 and -100 and the speed set to 0 temporarily to assign the SAFE switch in the flap system menu. Then change the flap system values back to the listing in the Tx setup. See the *SAFE Select Switch Designation* section of this manual to assign the switch for SAFE Select.

† Some of the terminology and function locations used in the iX12 and iX20 programming may be slightly different than other Spektrum AirWare™ radios. The names given in parentheses correspond to the iX12 and iX20 programming terminology. Consult your transmitter manual for specific information about programming your transmitter.

Pre-Programmed Transmitter Setup Files

To save time when setting up your transmitter for this model, visit www.SpektrumRC.com to download the latest pre-programmed transmitter setup files. The files are found under "SETUPS/UPDATES" and the "AIR TRANSMITTER SETUPS" link. Select your radio/transmitter, then on the corresponding page under "SETUPS & DOWNLOADS" click the "DOWNLOAD SETUPS" button to view the available files in the drop down list. Locate the file for this model using the item number. Download the correct model file to and install it in your transmitter using an SD card.

Dual Rates

Low rate is recommended for the initial flights.

NOTICE: To ensure AS3X® technology functions properly, do not lower rate values below 50%. If lower rates are desired, manually adjust the position of the pushrods on the servo arm.

NOTICE: If oscillation occurs at high speed, refer to the Troubleshooting Guide for more information.

Computerized Transmitter Setup

Start all transmitter programming with a blank ACRO model (perform a model reset), then name the model.

Set Dual Rates to	2 Position switch	3 Position switch
	HIGH 100%	HIGH 100%
	LOW 70%	MID 70%
		LOW 50%
Set Servo Travel to	100%	
Set Throttle Cut to	-100%	
DX6e ‡	1. Go to the SYSTEM SETUP (Model Utilities)†	
DX6 ‡ (Gen2)	2. Set MODEL TYPE: AIRPLANE	
DX7 ‡ (Gen2)	3. Set AIRCRAFT TYPE: (Model Setup, Aircraft Type)†: WING: 1 AIL 1 FLAP	
NX6†		
DX8e	5. Go to the FUNCTION LIST (Model Adjust)†	
DX8 (Gen2)	6. Select Servo Setup -> Reverse -> Reverse GEAR (CH5)	
DX9		
DX10t	7. Select FLAP SYSTEM: Set Switch; SWITCH D	
DX18	Pos 0: -100% FLAP	0% Elevator
DX20	Pos 1: 0% FLAP	-4% Elevator
iX12 †	Pos 2: 100% FLAP	-7% Elevator
iX20 †	Switch: Switch D	
NX8	Speed: 2.0s	
NX10		

Exponential

After first flights, you may adjust exponential in your transmitter.

Thrust Reversing

Motor reversing is not enabled by default. See the *Thrust Reversing* section of this manual for information on setting up and using the motor/thrust reversing function in the ESC.

Transmitter Telemetry Setup

If the transmitter that you intend to use with this aircraft is not displaying telemetry data, visit www.SpektrumRC.com and update your firmware. With the latest firmware installed on your transmitter the telemetry option should now be functional on your transmitter.

Differential Thrust

The Beechcraft D18 is equipped with differential thrust. When the rudder is applied one motor will increase speed and the other will decrease speed to assist with yaw control. This assists in ground handling, takeoff and landing.

For maximum control during takeoff and landing we recommend increasing the throttle trim until the motors just start spinning. Then reduce the trim until the motors stop. It is about 3-5 trim clicks. With the trim set in this position the rudder will allow one motor to spin to maintain directional control even with the throttle at idle.

With the trim set in this position we recommend you activate throttle cut if you pick up or move the aircraft. If the aircraft is picked up and yawed without the trim lowered or throttle cut activated, a motor may start spinning. Make sure everything is clear of the propellers when handling the aircraft.

PNP Receiver Selection and Installation

The recommended receiver for this aircraft is the Spektrum AR631. If you choose to install a different receiver, ensure that it is at least a 6-channel full range receiver. Refer to the manual of your chosen receiver for correct installation and operation instructions.

AR631 Installation

1. Push the button behind the hatch to release the hatch.
2. Remove the hatch by pulling up on the back of the hatch to expose the receiver compartment.
3. Connect the control surface servos to their respective ports on the receiver using the table at the right.
4. Using double-sided servo tape (not included) mount the receiver to the flat area of the receiver compartment, as shown. The receiver (A) should be mounted in the orientation shown, parallel to the length of the fuselage, with the label facing up and the servo ports facing the rear of the aircraft. The orientation of the receiver is critical for all AS3X® and SAFE® technology setups.
5. For single antenna receivers, route the antenna on the left side of the fuselage tube marked "Insert Antenna Here". For dual antenna receivers route the left antenna to the left side tube and the right antenna to the right side tube.



CAUTION: Incorrect installation of the receiver could cause a crash.

AR631 Port Assignments

BND/PRG = SRXL2

- 1 = Throttle**
- 2 = Aileron**
- 3 = Elevator**
- 4 = Rudder**
- 5 = GEAR/LEDs**
- 6 = Flaps**

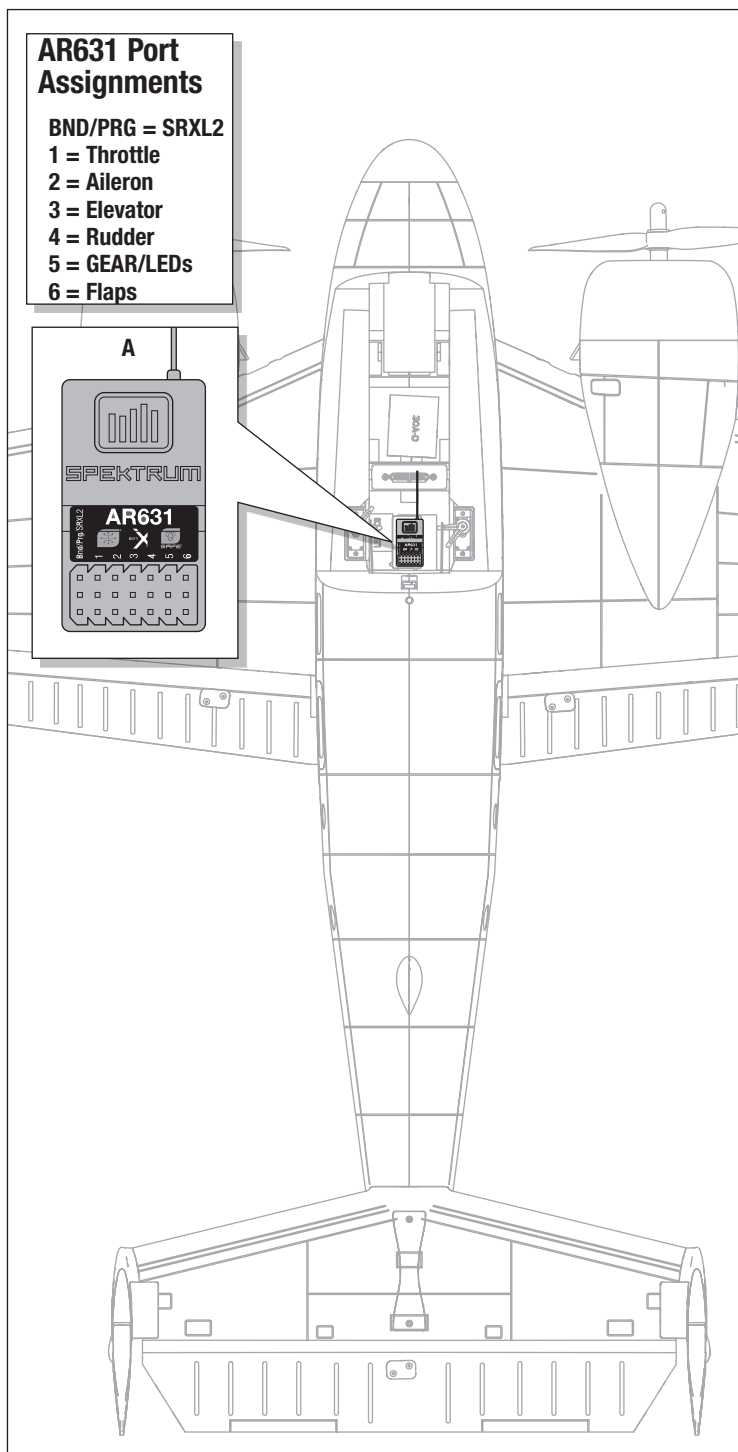

Battery Installation and ESC Arming

Battery Selection

We recommend the Spektrum 4000mAh 14.8V 4S 30C Li-Po battery (SPMX40004S30). Refer to the Optional Parts List for other suitable batteries. If using a battery other than those listed, the battery should be within the range of capacity, dimensions and weight of the Spektrum Li-Po battery packs to fit in the fuselage. Be sure the model balances at the recommended CG.

CAUTION: Always keep hands away from the propeller. When armed, the motor will turn the propeller in response to any throttle movement.

1. Lower the throttle and throttle trim to the lowest settings. Power on the Transmitter, then wait 5 seconds.
2. It is recommended to apply hook and loop tape (loop portion) (A) to the bottom of your battery.
3. Push the release button (B) and pull up on the back of the battery hatch (C) to remove.
4. Install the fully charged battery (D) in the battery compartment as shown. See the *Adjusting the Center of Gravity* instructions for more information.
5. Make sure the flight battery is secured using the hook and loop straps.
6. Connect the battery to the ESC.
7. Keep the aircraft level on its wheels, immobile and away from wind or the system will not initialize.

Once armed:

- The ESC will sound a series of tones (number of tones depend on the cell count of the battery).
 - The control surfaces will cycle once for AS3X, or twice for SAFE technology if it is turned ON.
 - An LED will light on the receiver.
8. Reinstall the battery hatch.

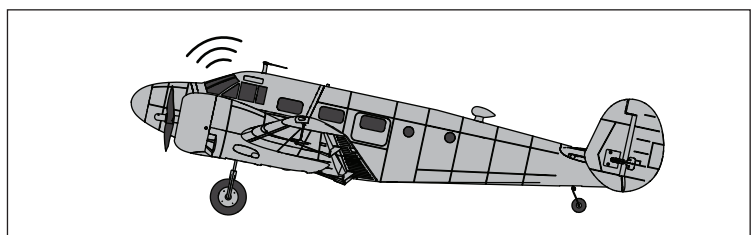
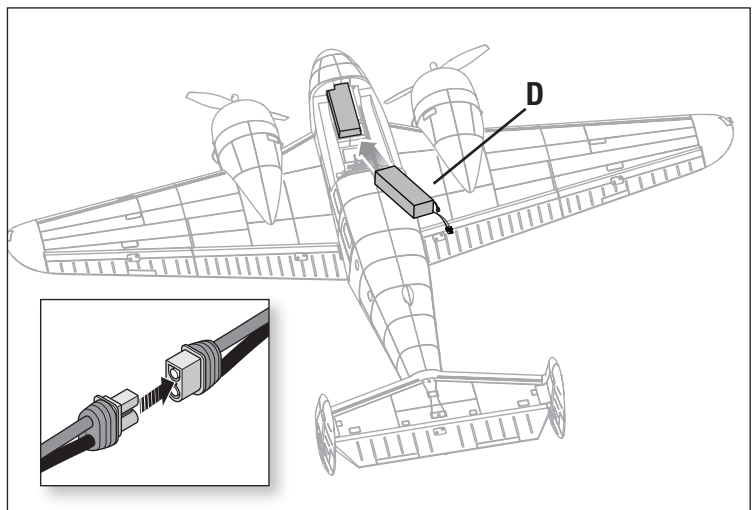
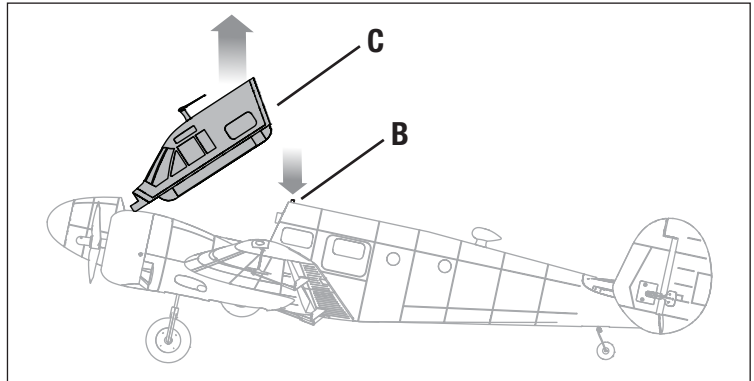
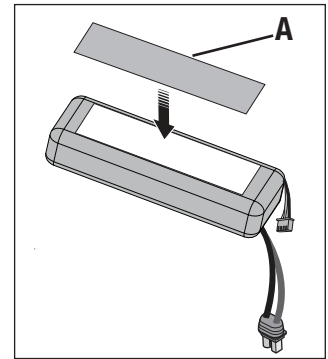
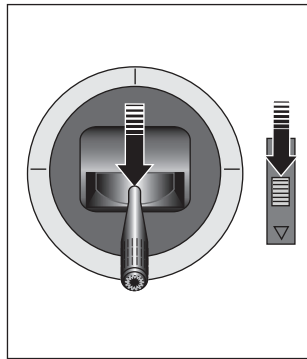

CAUTION: Always keep hands away from the propeller. When armed, the motor will turn the propellers in response to any throttle movement.

Binding

General Binding Tips and Failsafe

- The included receiver has been specifically programmed for operation of this aircraft. Refer to the receiver manual for correct setup if the receiver is replaced.
- Keep away from large metal objects while binding.
- Do not point the transmitter's antenna directly at the receiver while binding.
- The orange LED on the receiver will flash rapidly when the receiver enters bind mode.
- Once bound, the receiver will retain its bind settings for that transmitter until you re-bind.
- If the receiver loses transmitter communication, the failsafe will activate. Failsafe moves the throttle channel to low throttle. Pitch and roll channels move to actively stabilize the aircraft in a descending turn.
- If problems occur, refer to the troubleshooting guide or if needed, contact the appropriate Horizon Product Support office.

Transmitter and Receiver Binding / Enabling SAFE Select

The BNF Basic version of this airplane includes SAFE Select technology, enabling you to choose the level of flight protection. SAFE mode includes angle limits and automatic self leveling. AS3X mode provides the pilot with a direct response to the control sticks. SAFE Select is enabled or disabled during the bind process.

With SAFE Select disabled the aircraft is always in AS3X mode. With SAFE Select enabled the aircraft will be in SAFE Select mode all the time, or you can assign a switch to toggle between SAFE Select and AS3X modes.

IMPORTANT: Before binding, read the transmitter setup section in this manual and complete the transmitter setup table to ensure your transmitter is properly programmed for this aircraft.

IMPORTANT: Move the transmitter flight controls (rudder, elevators, and ailerons) and the throttle trims to neutral. Move the throttle to low before and during binding.

You can use either the bind button on the receiver or the conventional bind plug to complete the binding process.

A bind plug extension has been provided in BNF Basic version models. It will be labeled and located in the battery or radio compartment for easy access.

Using Bind Button SAFE Select Enabled

SAFE Select Enabled: The control surfaces cycle back and forth **twice** with a slight pause at neutral position every time the receiver is powered on.

SAFE Select Disabled

SAFE Select Disabled: The control surfaces cycle back and forth **once** every time the receiver is powered on.

Using Bind Plug SAFE Select Enabled

SAFE Select Enabled: The control surfaces cycle back and forth **twice** with a slight pause at neutral position every time the receiver is powered on.

SAFE Select Disabled

SAFE Select Disabled: The control surfaces cycle back and forth **once** every time the receiver is powered on.

SAFE Select can also be activated via Forward Programming in compatible transmitters.

SAFE® Select Switch Designation *BNF*

Stick Inputs

Once SAFE Select is enabled, you can choose to fly in SAFE mode full-time, or assign a switch. Any switch on any channel between 5 and 9 can be used on your transmitter.

If the aircraft is bound with SAFE Select disabled, the aircraft will be in AS3X mode exclusively.

CAUTION: Keep all body parts well clear of the propeller and keep the aircraft securely restrained in case of accidental throttle activation.

IMPORTANT: To be able to assign a switch, first verify:

- The aircraft was bound with SAFE Select enabled.
- Your choice for the SAFE Select switch is assigned to a channel between 5 and 9 (Gear, Aux1-4), and travel is set at 100% in each direction.
- The aileron, elevator, rudder and throttle direction are set to normal, not reverse.
- The aileron, elevator, rudder and throttle are set to 100% travel. If dual rates are in use, the switches need to be in the 100% position.

See your transmitter manual for more information about assigning a switch to a channel.

TIP: If a SAFE Select switch is desired for your 6-function aircraft, and you are using a 6 channel transmitter, the SAFE Select switch channel will have to be shared with either channel 5 or 6 of the transmitter.

Forward Programming

Assign the SAFE Select channel through forward programming on your compatible Spektrum transmitter.



For more information about setting SAFE Select and using Forward Programming, please refer to the following link for a detailed video:

<https://www.youtube.com/watch?v=o-46P066cik>

Assigning a Switch

1. Power on the transmitter.
2. Power on the aircraft.
3. Hold both transmitter sticks to the inside bottom corners, and toggle the desired switch 5 times quickly (1 toggle = full up and down).
4. The control surfaces of the aircraft will move, indicating the switch has been selected.

Repeat the process to assign a different switch or to deactivate the current switch.

SAFE Select Switch Assignment Stick Positions

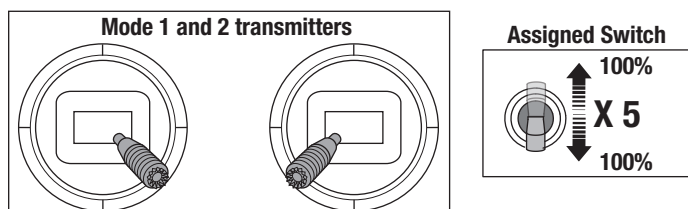

TIP: Use the channel monitor to verify channel movement.

This example of the channel monitor shows the stick positions for assigning a switch, the switch selection on Aux2, and +/- 100% travel on the switch.

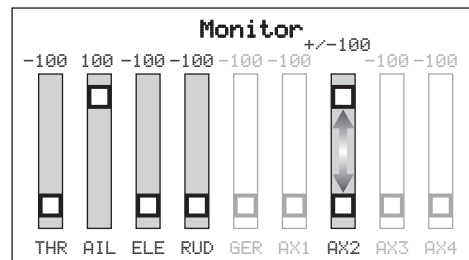

Forward Programming SAFE Select Setup

DX series, NX series, iX series	1. Begin with the transmitter bound to the receiver.
	2. Power ON the transmitter.
	3. Assign a switch for SAFE Select that is not already in use for another function. Use any open channel between 5 and 9 (Gear, Aux1-4).
	4. Set switch H (throttle cut) to prevent accidental motor operation.
	5. Power ON the aircraft. A signal bar appears on your transmitter's main screen when the telemetry information is being received.
	6. Go to the FUNCTION LIST (Model Setup)
	7. Select Forward Programming; Select Gyro Settings, Choose SAFE Select to enter the menu.
	8. Set SAFE Select Ch: To the channel you have chosen for SAFE Select.
	9. Set AS3X and SAFE On or Off as desired for each switch position.

Integrated ESC Telemetry

BNF: This aircraft includes telemetry between the ESC and receiver, which can provide information including RPM, voltage, motor current, throttle setting (%), and FET (speed controller) temperature.

PNP: The ESC in this aircraft is capable of delivering telemetry information over the throttle connection when paired with a Smart compatible Spektrum telemetry receiver. It will function with a normal PWM servo signal for common radio control systems.

For more information about compatible transmitters, firmware updates, and how to use the telemetry technology on your transmitter, visit www.SpektrumRC.com.

Telemetry Setup

DX series, NX series, iX series	1. Begin with the transmitter bound to the receiver.
	2. Power ON the transmitter.
	3. Set switch H (throttle cut) to prevent accidental motor operation.
	4. Power ON the aircraft. A signal bar appears on your transmitter's main screen when the telemetry information is being received.
	5. Go to the FUNCTION LIST (Model Setup)
	6. Select TELEMETRY; Smart ESC
	7. Set Total Cells: 4
	8. Set LVC Alarm: 3.4V Set Alarm; Voice/Vibe
	9. Set pole count; 14 pole

Control Direction Test

Switch on the transmitter and connect the battery. Use the transmitter to operate the aileron, elevator and rudder controls. View the aircraft from the rear when checking the control directions.

The BNF Basic version of this model has a built in aileron to rudder mix, when the ailerons are deflected the rudder will move.

Elevator

1. Pull the elevator stick back. The elevators should move up, which will cause the aircraft to pitch up.
2. Push the elevator stick forward. The elevators should move down, which will cause the aircraft to pitch down.

Ailerons



1. Move the aileron stick to the right. The right aileron should move up and the left aileron down, which will cause the aircraft to bank right.
1. Move the aileron stick to the left. The left aileron should move up and the right aileron down, which will cause the aircraft to bank left.

Rudders

1. Move the rudder stick to the right. The rudders should move to the right, which will cause the aircraft to yaw right.
1. Move the rudder stick to the left. The rudders should move to the left, which will cause the aircraft to yaw left.

Flaps

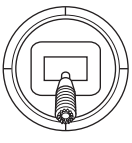
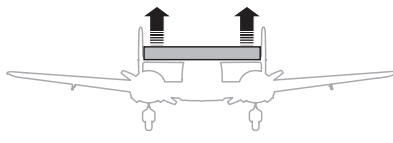
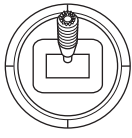
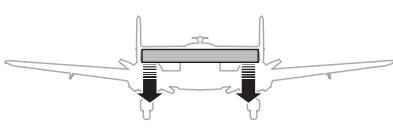
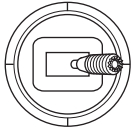
1. Move your flap control switch to the partial flaps position.
2. Confirm that the flaps move down.
3. Move flap control switch to the full flaps position.
4. Confirm the flaps move farther down than in step two.

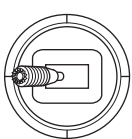
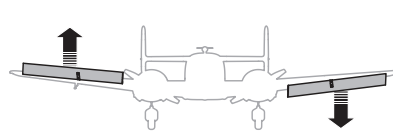
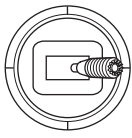
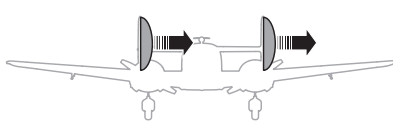
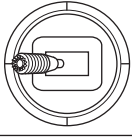
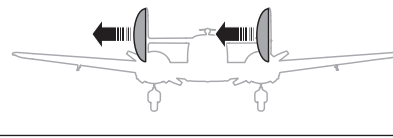
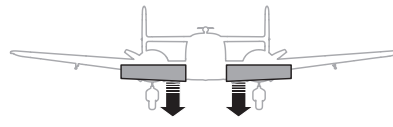
	Transmitter Command	Control Surface Response
Elevator		
		
Aileron		
		
Rudder		
		
Flaps		

AS3X Response Test

This test ensures that the AS3X® control system is functioning properly. Assemble the aircraft and bind your transmitter to the receiver before performing this test.



1. Raise the throttle just above 25%, then lower the throttle to activate AS3X.

CAUTION: Keep all body parts, hair and loose clothing away from a moving propeller, as these items could become entangled.

2. Move the entire aircraft as shown and ensure the control surfaces move in the direction indicated in the graphic. If the control surfaces do not respond as shown, do not fly the aircraft. Refer to the receiver manual for more information.

Once the AS3X system is active, control surfaces may move rapidly. This is normal. AS3X remains active until the battery is disconnected.

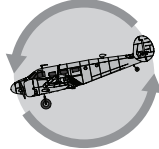
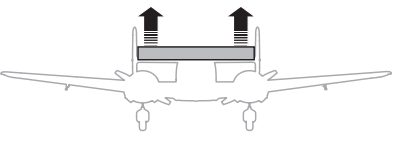
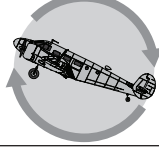
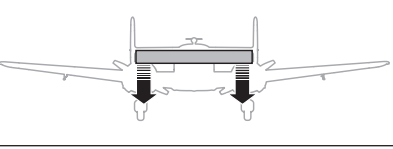
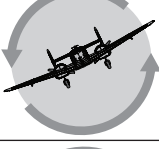
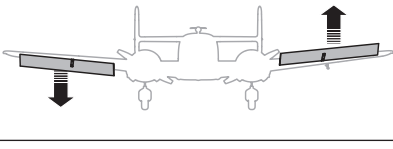
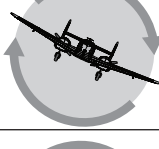
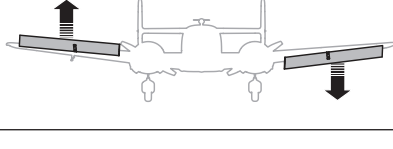
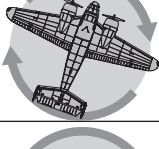
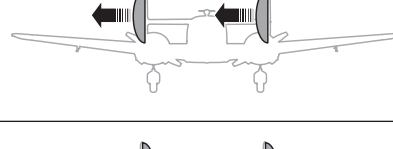
Due to different effects of torque, lift, and drag some aircraft require trim changes with different speeds and throttle settings. Mixes are preloaded into the receiver to compensate for these changes. The mixes become active the first time the throttle is raised above 25%. The control surfaces may be offset slightly at different throttle settings after the first time throttle is raised. Trimming the plane in flight should be done at 80-100% throttle for best results.

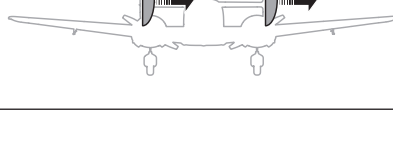
	Aircraft movement	AS3X Reaction
Elevator		
		
Aileron		
		
Rudder		
		

Control Surface Centering and Adjusting a Clevis

IMPORTANT: Perform the Control Direction Test before performing control surface centering.

While SAFE is inactive, mechanically center the control surfaces.

IMPORTANT: Correct operation of the SAFE system requires sub-trim and trim at 0.

After binding a transmitter to the receiver, set the trims and sub-trims to 0, ensure the servo arms are in the correct positions, then adjust the linkages to center the control surfaces.

- Slide the retaining tube off the clevis.
- Carefully spread the clevis, then insert the clevis pin into the desired hole in the control horn.
- Move the retaining tube to hold the clevis on the control horn.

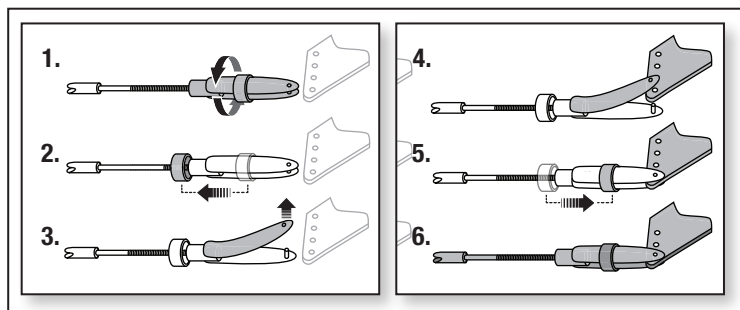
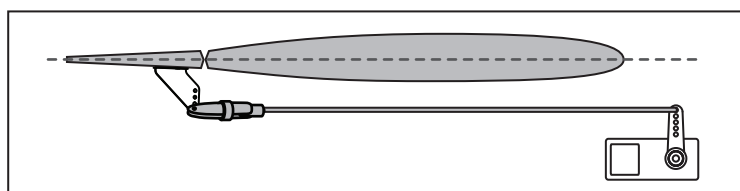

Control Horn and Servo Arm Factory Settings

The table to the right shows the factory settings for the control horns and servo arms. Fly the aircraft at factory settings before making changes.

After flying, you may choose to adjust the linkage positions for the desired control response. See the table to the right.

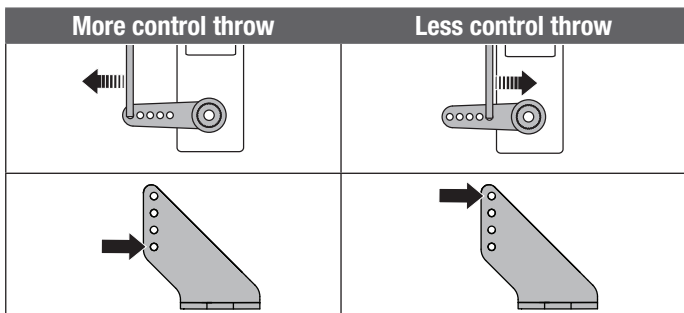

	Control Horns	Servo Arms
Elevator		
Rudder		
Ailerons		
Flaps		
Tail Wheel	<p>From Rudder Servo To Bellcrank</p>	

Dual Rates and Control Throws

Program your transmitter to set the rates and control throws to the values given. These values have been tested and are a good starting point to achieve successful flight.

After flying, you may choose to adjust the values for the desired control response.

	High Rate	Low Rate
Aileron	▲ = 18mm ▼ = 18mm	▲ = 12mm ▼ = 12mm
Elevator	▲ = 18mm ▼ = 16mm	▲ = 13mm ▼ = 11mm
Rudder	▶ = 20mm ◀ = 20mm	▶ = 15mm ◀ = 15mm
Flaps	Partial ▼ = 20mm	Full ▼ = 32mm

Center of Gravity (CG)

The CG location is measured from the panel line at the wing joint where the center section and the outer panel meet. This CG location has been determined with the recommended 4S 4000mAh battery (SPMX40004S30). Check the CG with the model inverted, with the landing gear retracted. Adjust the battery forward or aft as needed to achieve the proper CG location.

CAUTION: Install the battery but do not arm the ESC while checking the CG. Personal injury may result.

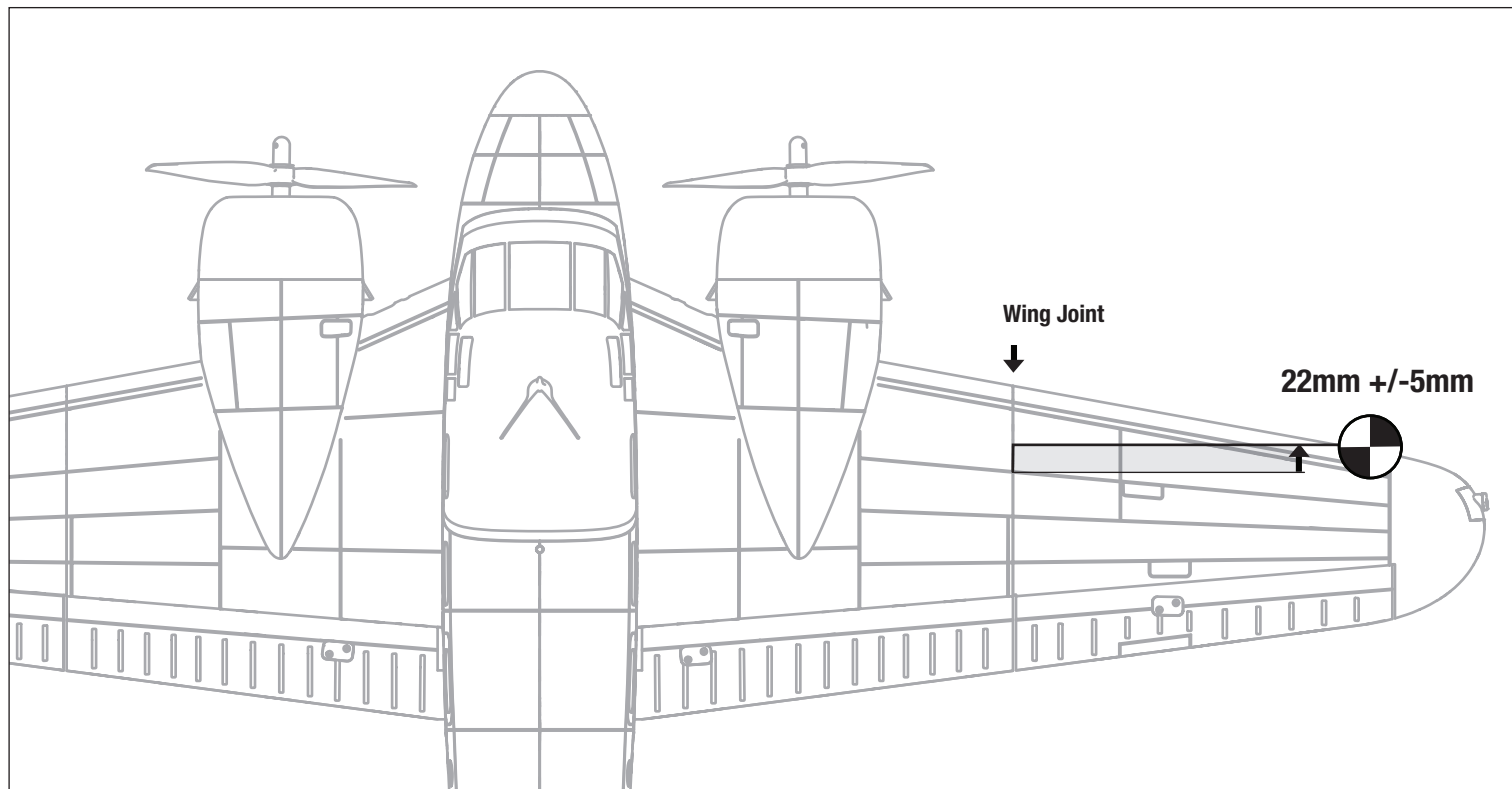

SAFE Select Flying Tips *BNF*

When flying in SAFE Select mode the aircraft will return to level flight any time the aileron and elevator controls are at neutral. Applying aileron or elevator control will cause the airplane to bank, climb or dive. The amount the stick is moved will determine the attitude the airplane flies. Holding full control will push the aircraft to the pre-determined bank and roll limits, but it will not go past those angles.

When flying with SAFE Select, it is normal to hold the control stick deflected with moderate aileron input when flying through a turn. To fly smoothly with SAFE Select, avoid making frequent control changes and don't attempt to correct for minor deviations. Holding deliberate control inputs will command the aircraft to fly at a specific angle, and the model will make all corrections to maintain that flight attitude.

When flying with SAFE Select, throttle will make the aircraft climb or descend. Full throttle will cause the aircraft to pitch up and climb slightly. Mid throttle will keep the airplane flying level. Low throttle will cause the airplane to descend slightly nose-down.

Return the elevator and aileron controls to neutral before switching from SAFE Select mode to AS3X mode. If you do not neutralize controls when switching into AS3X mode, the control inputs used for SAFE Select mode will be excessive for AS3X mode and the aircraft will react immediately.

Differences between SAFE Select and AS3X modes

This section is generally accurate but does not take into account flight speed, battery charge status, and other limiting factors.

		SAFE Select	AS3X
Control Input	Control stick is neutralized	Aircraft will self level	Aircraft will continue to fly at its present attitude
	Holding a small amount of control	Aircraft will bank or pitch to a moderate angle and maintain the attitude	Aircraft will continue to pitch or roll slowly
	Holding full control	Aircraft will bank or pitch to the predetermined limits and maintain the attitude	Aircraft will continue to roll or pitch rapidly
	Throttle	Full throttle: Climb Neutral: Level flight Low throttle: Descend	Throttle will not affect flight response.

In-Flight Trimming

During your first flight, trim the aircraft for level flight at 80-100% throttle. Make small trim adjustments with your transmitter's trim switches to achieve straight and level flight.

After adjusting trim do not touch the control sticks for 3 seconds. This allows the receiver to learn the correct settings to optimize AS3X performance.

Failure to do so could affect flight performance.

3 Seconds

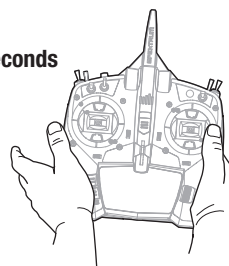

Post Flight

1. Disconnect the flight battery from the ESC (Required for Safety and battery life).

2. Power OFF the transmitter.

3. Remove the flight battery from the aircraft.

4. Recharge the flight battery.

5. Repair or replace all damaged parts.

6. Store the flight battery apart from the aircraft and monitor the battery charge.

7. Make note of the flight conditions and flight plan results, planning for future flights.

Thrust Reversing (Optional)

The Avian™ Smart ESC in this aircraft is equipped with thrust reversing, but it must be enabled before it will function. Reversing the motor can be helpful when taxiing or for shortening ground roll after a landing. Flipping the designated switch reverses motor rotation, throttle will still control motor speed.

WARNING: Never attempt to use thrust reversing in flight. Applying reverse thrust while in flight will result in loss of control and possibly a crash. Crash damage is not covered under warranty.

IMPORTANT: The motor will draw more current in reverse as the propeller becomes less efficient and creates more drag. This can reduce flight time.

IMPORTANT: Thrust reversing requires a Spektrum receiver with Smart Throttle (including the AR637TA and AR631) and a Spektrum transmitter with a minimum of 7 channels. The Avian ESC is also backwards compatible with conventional receivers (PWM output signal) for normal operation, but reversing functions are only available with Smart Throttle technology.

Thrust Reversing Setup

Transmitter

On the transmitter, select an open channel (not already in use), and assign it to an open switch. Use a different channel for thrust reversing and SAFE Select. Motor reversing is assigned to Aux 2/Channel 7, by default, in the Smart ESC. If SAFE Select and the ESC are assigned to the same channel, the motor will reverse in flight.

WARNING: Do not assign thrust reversing and SAFE Select to the same channel. Doing so will reverse the motor when SAFE Select is enabled during flight, resulting in a crash.

ESC

Program the ESC for thrust reversing with the Smart ESC Programming Box (SP-MXCA200, optional, not included).

Enabling the Motor / Thrust Reversing

1. Connect a 3+” servo extension to one of the short programming leads/ connectors.
2. Connect the other end of the extension to the Spektrum Smart ESC Programmer (SPMXCA200) using the port marked “ESC”. Match the polarity as marked. Note: Orange corresponds to gray on the ESC.
3. Remove the battery hatch from the fuselage.
4. Connect a flight battery to the IC3 connector to power the ESC.
5. On the programmer press the “EDIT” button.
6. Once you see the “Brake Type” Repeatedly press the “Edit” button until “Reverse” is selected.
7. Press “Select” to change the “Brake Force”.
8. Continue pressing the “Edit” button until “7” is shown and press “Select”.
9. The default channel is Channel 7, if you would like this on a different channel repeatedly press the “Select” button until “Thrust Rev” is shown. Repeatedly press the “Edit” button until the desired channel appears.
10. Press the “Save” button on the programmer to lock in the changes.
11. 12. Once complete, disconnect the extension from the programming lead and connect it to the other programming lead. Repeat steps 4-11.
12. Repeat steps 3-8.
13. The motor/thrust reverse feature is now enabled on the ESC.

Motor Service

CAUTION: Always disconnect the flight battery before performing motor service.

Disassembly

1. Remove the spinner (A), propeller (B), 4 screws (M3 x 8mm machine screws) (C) and prop adapter (D) from the motor shaft.
2. Remove 2 screws (2 x 6mm self tapping screws) (E), 1 screw (2 x 24mm self tapping screw) located in the bottom dummy engine cylinders (F), and remove the cowl (G).
3. Remove the 4 screws (M3 x 12mm) (H) from the motor mount (I).
4. Remove the motor and motor mount from the fuselage.
5. Disconnect the motor wires from the ESC wires.
6. Remove the 4 screws (M3 x 10mm) (J), 4 lock washers (K) and motor (L) from the motor mount.

Assembly

Assemble in reverse order.

- Correctly align and connect the motor wire colors with the ESC wires.
- Install the propeller as shown.
- Tighten the spinner by using screwdriver in the hole in the spinner nut. Turn both spinners clockwise to tighten.

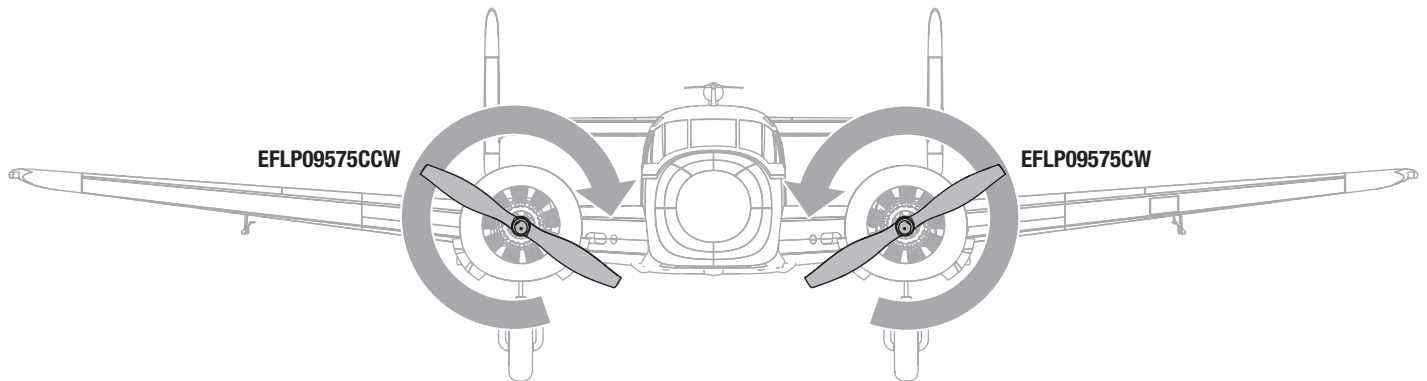
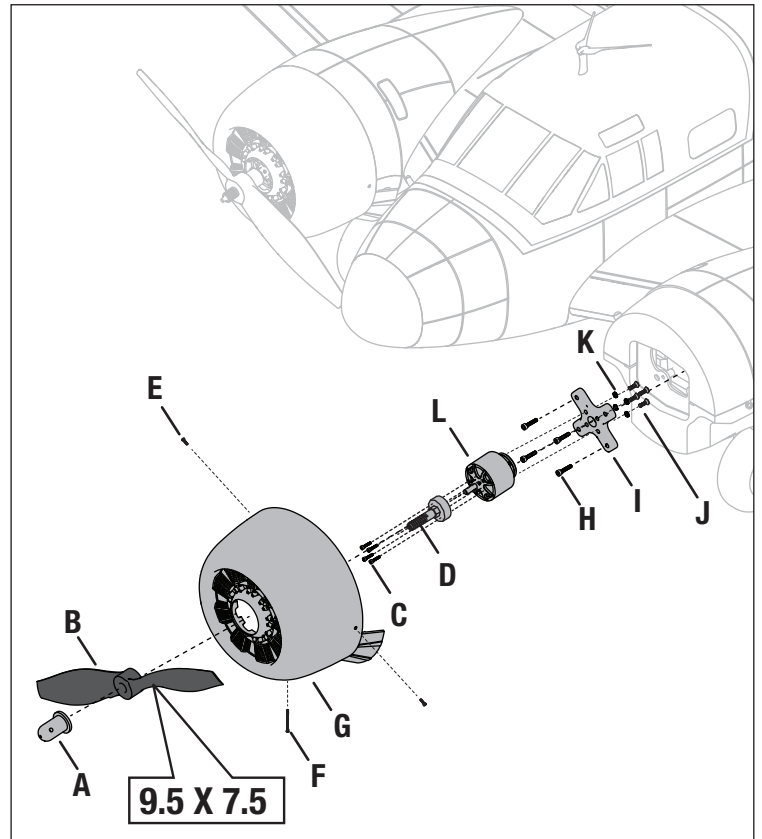

Rotation direction is referenced as if you are sitting in the cockpit

Servo Service

Control Surface	Replacement Servo	Description	Replacement Adhesive
Aileron	SPMSA382	A382 14g Sub-Micro MG Servo	Deluxe Materials Foam 2 Foam (DLMAD34)
Elevator			
Rudder			
Flaps			

Troubleshooting Guide AS3X

Problem	Possible Cause	Solution
Oscillation	Damaged propeller or spinner	Replace propeller or spinner
	Imbalanced propeller	Balance the propeller.
	Motor vibration	Replace parts or correctly align all parts and tighten fasteners as needed
	Loose receiver	Align and secure receiver in fuselage
	Loose aircraft controls	Tighten or otherwise secure parts (servo, arm, clevis, horn and control surface)
	Worn parts	Replace worn parts (especially propeller, spinner or servo)
	Irregular servo movement	Replace servo
Inconsistent flight performance	Trim is not at neutral	If you adjust trim more than 8 clicks, adjust the clevis to remove trim
	Sub-Trim is not at neutral	No Sub-Trim is allowed. Adjust the servo linkage
	Aircraft was not kept immobile for 5 seconds after battery connection	With the throttle stick in lowest position. Disconnect battery, then reconnect battery and keep the aircraft still for 5 seconds
Incorrect response to the AS3X Control Direction Test	Incorrect direction settings in the receiver, which can cause a crash	DO NOT fly. Contact Product Support for a solution.

Troubleshooting Guide

Problem	Possible Cause	Solution
Aircraft will not respond to throttle but responds to other controls	Throttle not at idle and/or throttle trim too high	Reset controls with throttle stick and throttle trim at lowest setting
	Throttle servo travel is lower than 100%	Make sure throttle servo travel is 100% or greater
	Throttle channel is reversed	Reverse throttle channel on transmitter
	Motor disconnected from ESC	Make sure motor is connected to the ESC
Extra propeller noise or extra vibration	Damaged propeller and spinner, prop adapter or motor	Replace damaged parts
	Propeller is out of balance	Balance or replace propeller
	Prop nut is too loose	Tighten the prop nut
Reduced flight time or aircraft underpowered	Flight battery charge is low	Completely recharge flight battery
	Propeller installed backwards	Install propeller with numbers facing forward
	Flight battery damaged	Replace flight battery and follow flight battery instructions
	Flight conditions may be too cold	Make sure battery is warm before use
	Battery capacity too low for flight conditions	Replace battery or use a larger capacity battery
Aircraft will not Bind (during binding) to transmitter	Transmitter too near aircraft during binding process	Move powered transmitter a few feet from aircraft, disconnect and reconnect flight battery to aircraft
	Aircraft or transmitter is too close to large metal object, wireless source or another transmitter	Move aircraft and transmitter to another location and attempt binding again
	The bind plug is not installed correctly in the bind port	Install bind plug in bind port and bind the aircraft to the transmitter
	Flight battery/transmitter battery charge is too low	Replace/recharge batteries
	Bind switch or button not held long enough during bind process	Power off transmitter and repeat bind process. Hold transmitter bind button or switch until receiver is bound
Aircraft will not connect (after binding) to transmitter	Transmitter too near aircraft during connecting process	Move powered transmitter a few feet from aircraft, disconnect and reconnect flight battery to aircraft
	Aircraft or transmitter is too close to large metal object, wireless source or another transmitter	Move aircraft and transmitter to another location and attempt connecting again
	Bind plug left installed in bind port	Rebind transmitter to the aircraft and remove the bind plug before cycling power
	Aircraft bound to different model memory (ModelMatch™ radios only)	Select correct model memory on transmitter
	Flight battery/Transmitter battery charge is too low	Replace/recharge batteries
	Transmitter may have been bound to a different aircraft using different DSM protocol	Bind aircraft to transmitter
Control surface does not move	Control surface, control horn, linkage or servo damage	Replace or repair damaged parts and adjust controls
	Wire damaged or connections loose	Do a check of wires and connections, connect or replace as needed
	Transmitter is not bound correctly or the incorrect airplanes was selected	Re-bind or select correct airplanes in transmitter
	Flight battery charge is low	Fully recharge flight battery
	BEC (Battery Elimination Circuit) of the ESC is damaged	Replace ESC

Troubleshooting Guide Continued

Problem	Possible Cause	Solution
Controls reversed	Transmitter settings are reversed	Perform the Control Direction Test and adjust the controls on transmitter appropriately
Motor pulses then motor loses power	ESC uses default soft Low Voltage Cutoff (LVC)	Recharge flight battery or replace battery that is no longer performing
	Weather conditions might be too cold	Postpone flight until weather is warmer
	Battery is old, worn out, or damaged	Replace battery
	Battery C rating might be too low	Use recommended battery

Replacement Parts

Part #	Description
EFL106251	Fuselage: Beechcraft D18
EFL106252	Wing Center Section: Beechcraft D18
EFL106253	Wing Panel; RH: Beechcraft D18
EFL106254	Wing Panel; LH: Beechcraft D18
EFL106255	Horizontal Stabilizer: Beechcraft D18
EFL106256	Fins; LH and RH: Beechcraft D18
EFL106257	Hatch With Pilot: Beechcraft D18
EFL106258	Main Landing Gear Struts (Pair): Beechcraft D18
EFL106259	Tailwheel and Arms: Beechcraft D18
EFL106260	Hardware Set: Beechcraft D18
EFL106261	Cowling (Pair): Beechcraft D18
EFL106262	Pushrod Set: Beechcraft D18
EFL106263	Hands Free Servo Connector: Beechcraft D18
EFL106264	Servo Extensions (Pair): Beechcraft D18
EFL106265	Wing Tube (Pair): Beechcraft D18
EFL106266	Wing and Tail Screws: Beechcraft D18
EFL106267	Motor Mount with Screws: Beechcraft D18
EFL106268	Decal Sheet: Beechcraft D18
EFL106269	Antenna Set: Beechcraft D18
EFL106270	Retract with Screws: Beechcraft D18
EFLA520B	LED set and Covers: Beechcraft D18
EFLP09575CCW	9.5 x 7.5 CCW Right Propeller: Beechcraft D18
EFLP09575CW	9.5 x 7.5 CW Left Propeller: Beechcraft D18
SPMAR631	AR631 6CH AS3X/SAFE Receiver
SPMSA382	14g Sub-Micro MG digital Servo, 140mm Lead
SPMXAE0240A	Avian 40A Twin Brushless Smart Lite ESC 3-4S
SPMXAM1700B	Brushless Outrunner 930Kv
EFL106271	Prop Adapter and Spinner Nut Beechcraft D18

Recommended Items

Part #	Description
SPMX40004S30	4000mAh 4S 14.8V Smart 30C; IC3
SPMR6775	NX6 6-Ch Transmitter Only
SPMXC2020	Smart S1200 G2 AC Charger; 1x200W

Optional Parts

Part #	Description
SPMR8200	NX8 8 Ch DSMX Transmitter Only
SPMX32004S30	3200mAh 4S 14.8V Smart 30C; IC3
SPMX40003S30	4000mAh 3S 11.1V Smart 30C; IC3
SPMX324S50	3200mAh 4S 14.8V 50C Smart G2 LiPo Battery: IC3
SPMX324S100	3200mAh 4S 14.8V Smart 100C G2 LiPo Battery: IC3
SPMXC2040	Smart S1200 G2 AC Charger; 1x200W
SPMXBC100	Smart Battery & Servo Tester
SPM6730	Smart Charger Case
SPMXCA300	Smart Lipo Bag, 16 x 7.5 x 6.5
ONXT1000	Ultimate Air/Surface Startup Tool Set

Important Federal Aviation Administration (FAA) Information

Use the QR code below to learn more about the **Recreational UAS Safety Test (TRUST)**, as was introduced by the 2018 FAA Reauthorization Bill. This free test is required by the FAA for all recreational flyers in the United States. The completed certificate must be presented upon request by any FAA or law enforcement official.



If your model aircraft weighs more than .55lbs or 250 grams, you are required by the FAA to register as a recreational flyer and apply your registration number to the outside of your aircraft. To learn more about registering with the FAA, use the QR code below.



AMA National Model Aircraft Safety Code

Academy of Model Aeronautics National Model Aircraft Safety Code

Effective January 1, 2018

A model aircraft is a non-human-carrying device capable of sustained flight within visual line of sight of the pilot or spotter(s). It may not exceed limitations of this code and is intended exclusively for sport, recreation, education and/or competition. All model flights must be conducted in accordance with this safety code and related AMA guidelines, any additional rules specific to the flying site, as well as all applicable laws and regulations.

As an AMA member I agree:

- I will not fly a model aircraft in a careless or reckless manner.
- I will not interfere with and will yield the right of way to all human-carrying aircraft using AMA's See and Avoid Guidance and a spotter when appropriate.
- I will not operate any model aircraft while I am under the influence of alcohol or any drug that could adversely affect my ability to safely control the model.
- I will avoid flying directly over unprotected people, moving vehicles, and occupied structures.
- I will fly Free Flight (FF) and Control Line (CL) models in compliance with AMA's safety programming.
- I will maintain visual contact of an RC model aircraft without enhancement other than corrective lenses prescribed to me. When using an advanced flight system, such as an autopilot, or flying First-Person View (FPV), I will comply with AMA's Advanced Flight System programming.
- I will only fly models weighing more than 55 pounds, including fuel, if certified through AMA's Large Model Airplane Program.
- I will only fly a turbine-powered model aircraft in compliance with AMA's Gas Turbine Program.
- I will not fly a powered model outdoors closer than 25 feet to any individual, except for myself or my helper(s) located at the flightline, unless I am taking off and landing, or as otherwise provided in AMA's Competition Regulation.
- I will use an established safety line to separate all model aircraft operations from spectators and bystanders.

Limited Warranty

What this Warranty Covers

Horizon Hobby, LLC, (Horizon) warrants to the original purchaser that the product purchased (the "Product") will be free from defects in materials and workmanship at the date of purchase.

What is Not Covered

This warranty is not transferable and does not cover (i) cosmetic damage, (ii) damage due to acts of God, accident, misuse, abuse, negligence, commercial use, or due to improper use, installation, operation or maintenance, (iii) modification of or to any part of the Product, (iv) attempted service by anyone other than a Horizon Hobby authorized service center, (v) Product not purchased from an authorized Horizon dealer, (vi) Product not compliant with applicable technical regulations, or (vii) use that violates any applicable laws, rules, or regulations.

OTHER THAN THE EXPRESS WARRANTY ABOVE, HORIZON MAKES NO OTHER WARRANTY OR REPRESENTATION, AND HEREBY DISCLAIMS ANY AND ALL IMPLIED WARRANTIES, INCLUDING, WITHOUT LIMITATION, THE IMPLIED WARRANTIES OF NON-INFRINGEMENT, MERCHANTABILITY AND FITNESS FOR A PARTICULAR PURPOSE. THE PURCHASER ACKNOWLEDGES THAT THEY ALONE HAVE DETERMINED THAT THE PRODUCT WILL SUITABLY MEET THE REQUIREMENTS OF THE PURCHASER'S INTENDED USE.

Purchaser's Remedy

Horizon's sole obligation and purchaser's sole and exclusive remedy shall be that Horizon will, at its option, either (i) service, or (ii) replace, any Product determined by Horizon to be defective. Horizon reserves the right to inspect any and all Product(s) involved in a warranty claim. Service or replacement decisions are at the sole discretion of Horizon. Proof of purchase is required for all warranty claims. SERVICE OR REPLACEMENT AS PROVIDED UNDER THIS WARRANTY IS THE PURCHASER'S SOLE AND EXCLUSIVE REMEDY.

Limitation of Liability

HORIZON SHALL NOT BE LIABLE FOR SPECIAL, INDIRECT, INCIDENTAL OR CONSEQUENTIAL DAMAGES, LOSS OF PROFITS OR PRODUCTION OR COMMERCIAL LOSS IN ANY WAY, REGARDLESS OF WHETHER SUCH CLAIM IS BASED IN CONTRACT, WARRANTY, TORT, NEGLIGENCE, STRICT LIABILITY OR ANY OTHER THEORY OF LIABILITY, EVEN IF HORIZON HAS BEEN ADVISED OF THE POSSIBILITY OF SUCH DAMAGES. Further, in no event shall the liability of Horizon exceed the individual price of the Product on which liability is asserted. As Horizon has no control over use, setup, final assembly, modification or misuse, no liability shall be assumed nor accepted for any resulting damage or injury. By the act of use, setup or assembly, the user accepts all resulting liability. If you as the purchaser or user are not prepared to accept the liability associated with the use of the Product, purchaser is advised to return the Product immediately in new and unused condition to the place of purchase.

Law

These terms are governed by Illinois law (without regard to conflict of law principals). This warranty gives you specific legal rights, and you may also have other rights which vary from state to state. Horizon reserves the right to change or modify this warranty at any time without notice.

WARRANTY SERVICES

Questions, Assistance, and Services

Your local hobby store and/or place of purchase cannot provide warranty support or service. Once assembly, setup or use of the Product has been started, you must contact your local distributor or Horizon directly. This will enable Horizon to better answer your

questions and service you in the event that you may need any assistance. For questions or assistance, please visit our website at www.horizonhobby.com, submit a Product Support Inquiry, or call the toll free telephone number referenced in the Warranty and Service Contact Information section to speak with a Product Support representative.

Inspection or Services

If this Product needs to be inspected or serviced and is compliant in the country you live and use the Product in, please use the Horizon Online Service Request submission process found on our website or call Horizon to obtain a Return Merchandise Authorization (RMA) number. Pack the Product securely using a shipping carton. Please note that original boxes may be included, but are not designed to withstand the rigors of shipping without additional protection. Ship via a carrier that provides tracking and insurance for lost or damaged parcels, as Horizon is not responsible for merchandise until it arrives and is accepted at our facility. An Online Service Request is available at http://www.horizonhobby.com/content/service-center_render-service-center. If you do not have internet access, please contact Horizon Product Support to obtain a RMA number along with instructions for submitting your product for service. When calling Horizon, you will be asked to provide your complete name, street address, email address and phone number where you can be reached during business hours. When sending product into Horizon, please include your RMA number, a list of the included items, and a brief summary of the problem. A copy of your original sales receipt must be included for warranty consideration. Be sure your name, address, and RMA number are clearly written on the outside of the shipping carton.

NOTICE: Do not ship LiPo batteries to Horizon. If you have any issue with a LiPo battery, please contact the appropriate Horizon Product Support office.

Warranty Requirements

For Warranty consideration, you must include your original sales receipt verifying the proof-of-purchase date. Provided warranty conditions have been met, your Product will be serviced or replaced free of charge. Service or replacement decisions are at the sole discretion of Horizon.

Non-Warranty Service

Should your service not be covered by warranty, service will be completed and payment will be required without notification or estimate of the expense unless the expense exceeds 50% of the retail purchase cost. By submitting the item for service you are agreeing to payment of the service without notification. Service estimates are available upon request. You must include this request with your item submitted for service. Non-warranty service estimates will be billed a minimum of ½ hour of labor. In addition you will be billed for return freight. Horizon accepts money orders and cashier's checks, as well as Visa, MasterCard, American Express, and Discover cards. By submitting any item to Horizon for service, you are agreeing to Horizon's Terms and Conditions found on our website http://www.horizonhobby.com/content/service-center_render-service-center.

ATTENTION: Horizon service is limited to Product compliant in the country of use and ownership. If received, a non-compliant Product will not be serviced. Further, the sender will be responsible for arranging return shipment of the un-serviced Product, through a carrier of the sender's choice and at the sender's expense. Horizon will hold non-compliant Product for a period of 60 days from notification, after which it will be discarded.

Contact Information

Country of Purchase	Horizon Hobby	Contact Information	Address
United States of America	Horizon Service Center (Repairs and Repair Requests)	servicecenter.horizonhobby.com/RequestForm/	2904 Research Rd Champaign, Illinois, 61822 USA
	Horizon Product Support (Product Technical Assistance)	productsupport@horizonhobby.com 877-504-0233	
	Sales	websales@horizonhobby.com 800-338-4639	
European Union	Horizon Technischer Service Sales: Horizon Hobby GmbH	service@horizonhobby.de +49 (0) 4121 2655 100	Hanskampring 9 D 22885 Barsbüttel, Germany

FCC Information

FCC ID: BRWSPMSR6200A

Supplier's Declaration of Conformity

EFL Beechcraft D18 1.5M BNF Basic and PNP (EFL106250/EFL106275)

 This device complies with part 15 of the FCC Rules. Operation is subject to the following two conditions: (1) This device may not cause harmful interference, and (2) this device must accept any interference received, including interference that may cause undesired operation.

 **CAUTION:** Changes or modifications not expressly approved by the party responsible for compliance could void the user's authority to operate the equipment.

NOTE: This equipment has been tested and found to comply with the limits for a Class B digital device, pursuant to part 15 of the FCC Rules. These limits are designed to provide reasonable protection against harmful interference in a residential installation. This equipment generates, uses and can radiate radio frequency energy and, if not installed and used in accordance with the instructions, may cause harmful interference to radio communications. However, there is no guarantee that interference will not occur in a particular installation. If this equipment does cause harmful interference to radio or television reception, which can be determined by turning the equipment off and on, the user is encouraged to try to correct the interference by one or more of the following measures:

- Reorient or relocate the receiving antenna.
- Increase the separation between the equipment and receiver.
- Connect the equipment into an outlet on a circuit different from that to which the receiver is connected.
- Consult the dealer or an experienced radio/TV technician for help.

Horizon Hobby, LLC
2904 Research Rd.,
Champaign, IL 61822
Email: compliance@horizonhobby.com
Web: HorizonHobby.com

IC Information

IC: 6157A-SPMSR6200A

CAN ICES-3 (B)/NMB-3(B)

This device contains license-exempt transmitter(s)/receivers(s) that comply with Innovation, Science, and Economic Development Canada's license-exempt RSS(s). Operation is subject to the following 2 conditions:

1. This device may not cause interference.
2. This device must accept any interference, including interference that may cause undesired operation of the device.

Compliance Information for the European Union

 **EU Compliance Statement:**
EFL Beechcraft D18 1.5M PNP (EFL106275); Hereby, Horizon Hobby, LLC declares that the device is in compliance with the following: EU EMC Directive 2014/30/EU, RoHS 2 Directive 2011/65/EU, RoHS 3 Directive - Amending 2011/65/EU Annex II 2015/863

EFL Beechcraft D18 1.5M BNF Basic (EFL106250); Hereby, Horizon Hobby, LLC declares that the device is in compliance with the following: EU Radio Equipment Directive 2014/53/EU, RoHS 2 Directive 2011/65/EU, RoHS 3 Directive - Amending 2011/65/EU Annex II 2015/863

The full text of the EU declaration of conformity is available at the following internet address: <https://www.horizonhobby.com/content/support-render-compliance>.

Wireless Frequency Range and Wireless Output Power:

2404-2476MHz
5.58dBm

WEEE NOTICE:



This appliance is labeled in accordance with European Directive 2012/19/EU concerning waste of electrical and electronic equipment (WEEE). This label indicates that this product should not be disposed of with household waste. It should be deposited at an appropriate facility to enable recovery and recycling.

EU Manufacturer of Record:

Horizon Hobby, LLC
2904 Research Road
Champaign, IL 61822 USA

EU Importer of Record:

Horizon Hobby, GmbH
Hanskampring 9
22885 Barsbüttel Germany

Australia/New Zealand:





©2022 Horizon Hobby, LLC.

E-flite, Avian, Plug-N-Play, Bind-N-Fly, BNF, the BNF logo, DSM, DSM2, DSMX, Spektrum AirWare, IC3, IC5, AS3X, SAFE, the SAFE logo, the Smart Technology logo, ModelMatch, and the Horizon Hobby logo are trademarks or registered trademarks of Horizon Hobby, LLC.

The Spektrum trademark is used with permission of Bachmann Industries, Inc.

All other trademarks, service marks and logos are property of their respective owners. US 8,672,726. US 9,056,667. US 9,753,457. US 10,078,329. US 9,930,567. US 10,419,970 . US 10,849,013.

Other patents pending.

<http://www.horizonhobby.com/>