

PRODUCT RECALL: Tail Rotor Blade Grips of Blade 500-Size Helicopters



September 30, 2013

Products: Tail Rotor Blade Grip of Blade 500 X BNF (BLH4080), Blade 500 3D RTF (BLH1800, BLH1800M1) and Blade 500 3D BNF Basic (BLH1850).

Defect Issue: This product recall addresses the tail rotor blade grips that secure the tail rotor blades to the tail rotor hub. There is a possibility these grips may fail, causing the grips to separate from the hub. The separation of the grips from the hub during flight will cause a product failure, and may result in damage to property and injury.

What To Do: Examine your product. If the tail rotor grips match the defective ones pictured below on left, perform the corrective action below. These grips will be replaced by Horizon Hobby at no charge. If the tail rotor grips match those pictured on the right, no action is necessary and you can continue to use your product.

Corrective Action:

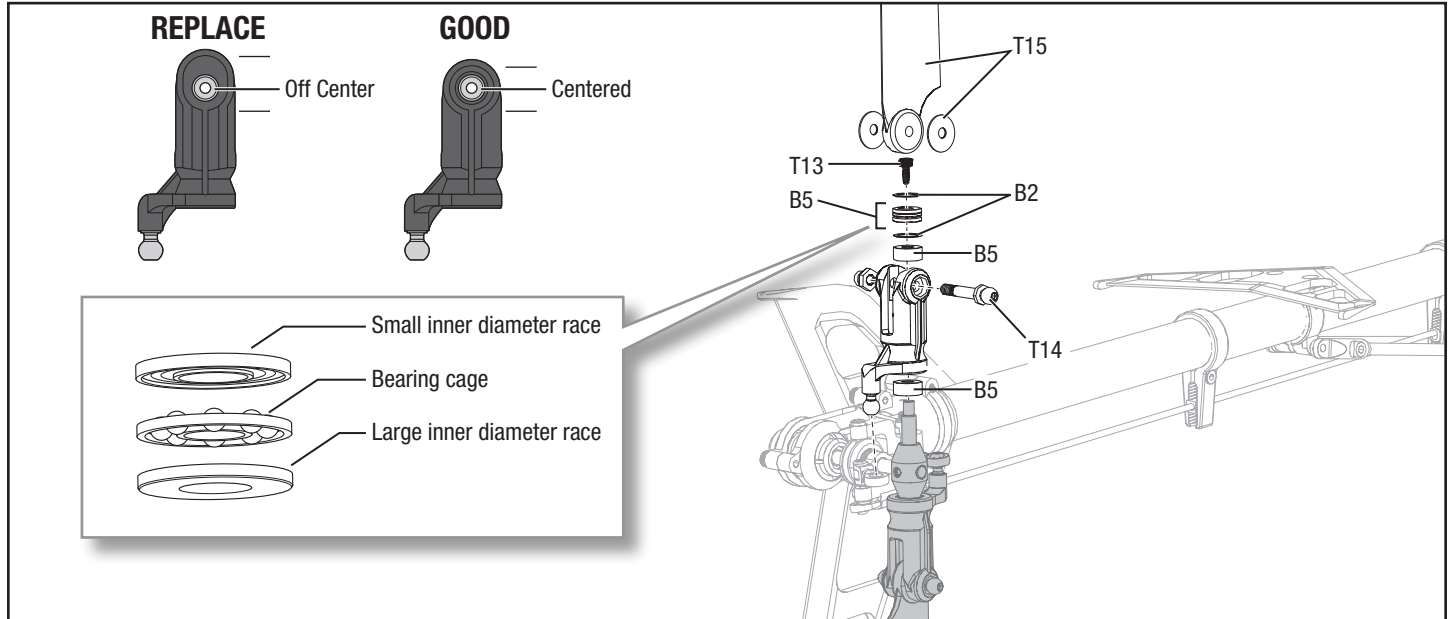

1. Remove the tail blade bolt (T14) securing the blade in the grip and remove the tail blade and washers (T15).
2. Remove the bolt securing the grip to the tail hub (T13).
3. Remove the grip assembly.
4. Remove the bearings and washers (B2 & B5) from the grip.
5. Please complete the electronic Return Request Form by clicking [here](http://www.bladehelis.com/ProdInfo/Files/BLH_500_Heli_TailGrip_ReturnForm.pdf) or pasting the link <http://www.bladehelis.com/ProdInfo/Files/BLH_500_Heli_TailGrip_ReturnForm.pdf> into your browser.
6. Upon receipt of the completed form, a replacement grip set, prepaid shipping label and return packaging will be sent to you. Return the original grip set only (not the helicopter) along with a printed copy of the completed Return Request Form using the packaging the new grips were shipped in.
7. After receiving the replacement grips, install them using the instructions above in reverse order. Ensure you reassemble the bearings in the proper orientation (see illustration). Make sure to apply medium-strength threadlock to the screws and allow time for the threadlock (about 4 to 6 hours) to dry before attempting to fly your helicopter. If you have any questions, please call Horizon Hobby Product Support at 888-959-2304.

If you purchased your product outside of US and Canada, please see the retailer or distributor you purchased your product from for assistance.

We apologize for this inconvenience. Horizon disclaims all liability and warranties for any consumer failing to act upon this product recall.

Contact Information

Country of Purchase	Horizon Hobby	Contact Information	Address
United States of America	Horizon Product Support (Product Technical Assistance)	www.quickbase.com/db/ bghj7ey8c?a=GenNewRecord 888-959-2304	4105 Fieldstone Rd Champaign, Illinois, 61822 USA
	Sales	sales@horizonhobby.com 888-959-2304	