

**RC10
RETRO 80'S**
1:10 OFF ROAD RACING
ULTRA CHAMP

1:10 Scale 2WD Electric Off Road
Competition Buggy Kit

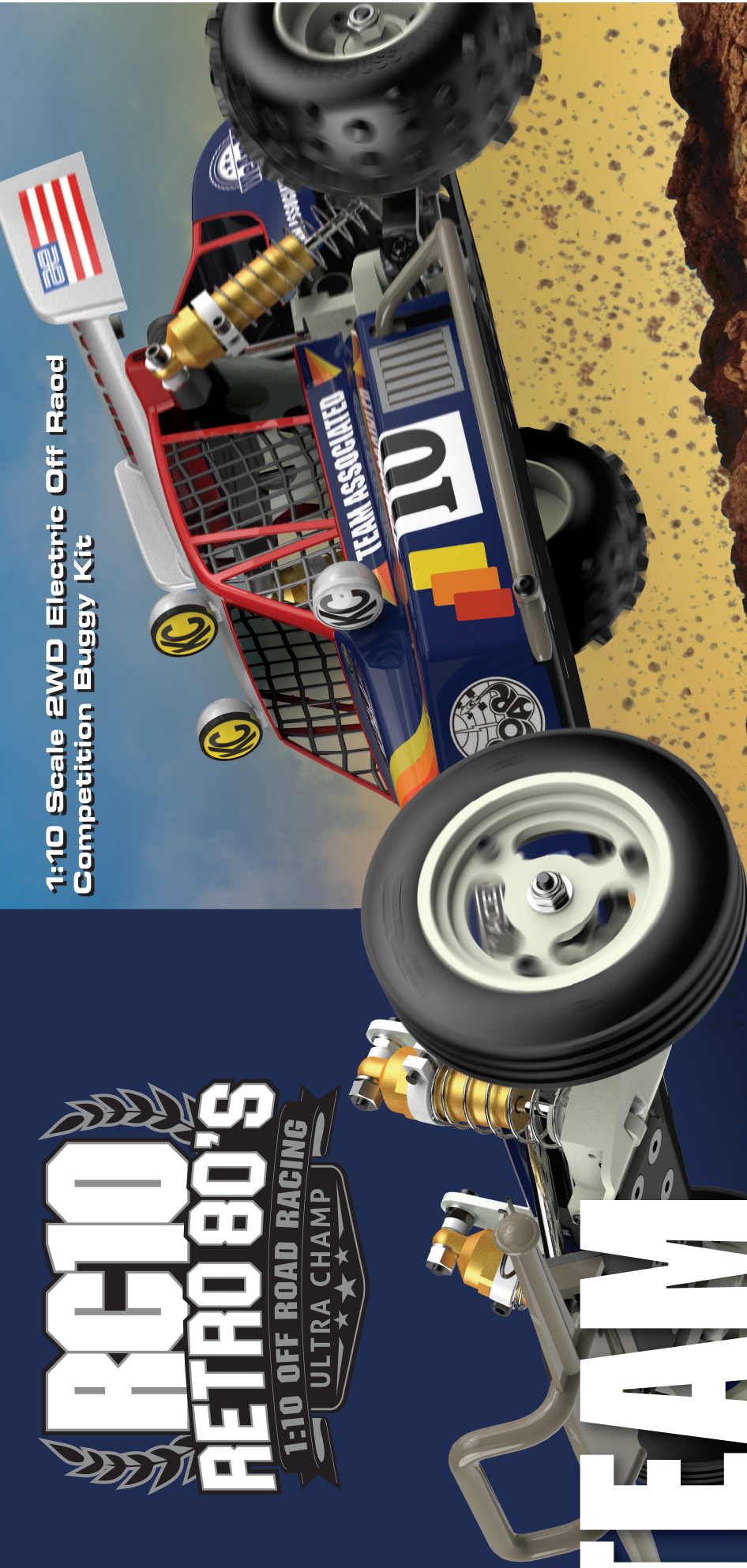

TEAM ASSOCIATED



1:10 Scale 2WD Electric Off Road Competition Buggy Kit Manual

#6050 RC10 Ultra Champ Retro 80's Kit



CHAMPIONS by DESIGN

AssociatedElectrics.com

TEAM ASSOCIATED

:: Introduction

Thank you for purchasing this Team Associated product. This assembly manual contains instructions and tips for building and maintaining your new Kit. Please take a moment to read through this manual to help familiarize yourself with these steps. We are continually changing and improving our designs; therefore, actual parts may appear slightly different than in the illustrations. New parts will be noted on supplementary sheets located in the appropriate parts bags. Check each bag for these sheets before you start to build.

:: KIT Features

- 80's Retro themed RC10 Classic
- New molded side guards
- New molded front bumper
- New CNC rear arm mounts with set screws
- New molded rear bulkheads
- New aluminum rear arm mount plates
- Hardened rear driveshafts
- New forged aluminum rear trailing suspension arms
- Long travel, fluid-filled anodized aluminum coil-over shocks
- Sealed 3-gear Stealth A.T.C. transmission
- High-torque ball differential
- Exceptional ground clearance with low center of gravity
- Front and rear tires with 3-piece racing wheels
- Clear Protech body with cutout templates
- Fiberglass shock towers
- Full metal ball bearings
- Fits 6-cell NiMH and 2S LiPo battery packs

:: Additional

Your new RC10 comes as a kit. There are some items you will need to complete your kit (refer to website for suggestions):

- R/C two channel surface frequency radio system
- 2S, 7.4V Lipo stick battery or 7.2V NiMH battery
- Steering Servo / Servo horn
- Polycarbonate specific paint
- Pinion gear, size to be determined by type and wind of motor you use
- Electronic Speed Control (ESC)
- Peak detection battery charger
- R/C Electric Motor
- Thread Lock (AE #1596)

Tools included:

- Allen wrenches (.035", .050", 1/16", 3/32")
- Shock building tool

:: Other Helpful Items

- Silicone Shock Fluid (Refer to website for complete listings)
- Tire Adhesive (AE #1697)
- Shock Pliers (AE #1681)
- Wire Cutters / Hobby Knife
- Body Scissors (AE #1737)
- Green Slime shock lube (AE #1105)
- Needle Nose Pliers
- Reamer / Hole Punch (AE #1499)
- Calipers or a Precision Ruler
- Soldering Iron

Associated Electrics, Inc.
21062 Bake Parkway
Lake Forest, CA 92630



Customer Service
Tel: 949.544.7500
Fax: 949.544.7501

:: Hardware - 1:1 Scale View

Cap Head (shcs)

	4-40x1/4"
	4-40x5/16"
	4-40x3/8"
	4-40x1/2"
	4-40x5/8" (6926)
	4-40x3/4"
	4-40x1"

Flat Head (fhcs)

	4-40x3/8"
	4-40x1/2"
	8-32x1/4" (6316)
	8-32x1/2" (6316)
	8-32x7/8" (6316)

Button Head (bhcs)

	0-80x3/16"
	4-40x3/16"
	4-40x1/4"
	4-40x3/8"
	3x6mm (31531)

Shims and Washers

	Dogbone spacer
	.030 Nylon Spacer (4187)
#4 Washer"/>	#4 Washer
	1/4" Axle Shim
	Diff Thrust Washers
	5mm x 9.5mm 0.17mm
#8 Aluminum Thick Washer"/>	#8 Aluminum Thick Washer

Nuts (lock/plain)

	4-40 Small Pattern Plain Nut
	4-40 Nuts
	5-40 Locknut
	8-32 Steel Locknut

Set Screws

	4-40x1/8"
	4-40x5/16"

Diff Balls

	5/64 Thrust Balls
	3/32 Diff Balls

Clips

	E-clip 1/8" (6299)
--	---------------------------

Bearings

	1/8 x 5/16 x 1/16
	5/32 x 5/16 x 1/8
	1/4 x 3/8 x 1/8
	3/16 x 3/8 x 1/8
	3/16 x 5/16 x 1/8
	3/8 x 5/8 x 5/32
	1/4 x 3/8 x 1/8 Flanged
	3/16 x 5/16 x 1/8 Flanged
	3/16 x 5/16 x 1/4 Flanged

Notes:

:: Table of Contents

1..... Cover	12..... Turnbuckles Build (Bag F)
2..... Introduction	13..... Shocks Build (Bag G)
3..... 1:1 Hardware "Fold Out"	15 Chassis Build (Bag H)
4..... Table of Contents	16..... Steering Servo Build (Bag I)
5..... Nose Plate / Steering Build (Bag A)	16..... Wheels, Tires and Body Install (Bag J)
5..... Front Suspension Build (Bag B)	21..... Notes
7..... Transmission Build (Bag C)	22..... Back Cover
9..... Rear Bulkhead Build (Bag D)	
10..... Rear Suspension Build (Bag E)	

:: Notes

This symbol indicates a special note or instruction in the manual.



There is a 1:1 hardware foldout page in the front of the manual. To check the size of a part, line up your hardware with the correct drawing until you find the exact size.

Associated Electrics, Inc.
21062 Bake Parkway
Lake Forest, CA 92630



Customer Service
Tel: 949.544.7500
Fax: 949.544.7501

:: Nose Plate / Steering Build - Bag A - Step 1

!
Washers are used to adjust to your preferred body height.

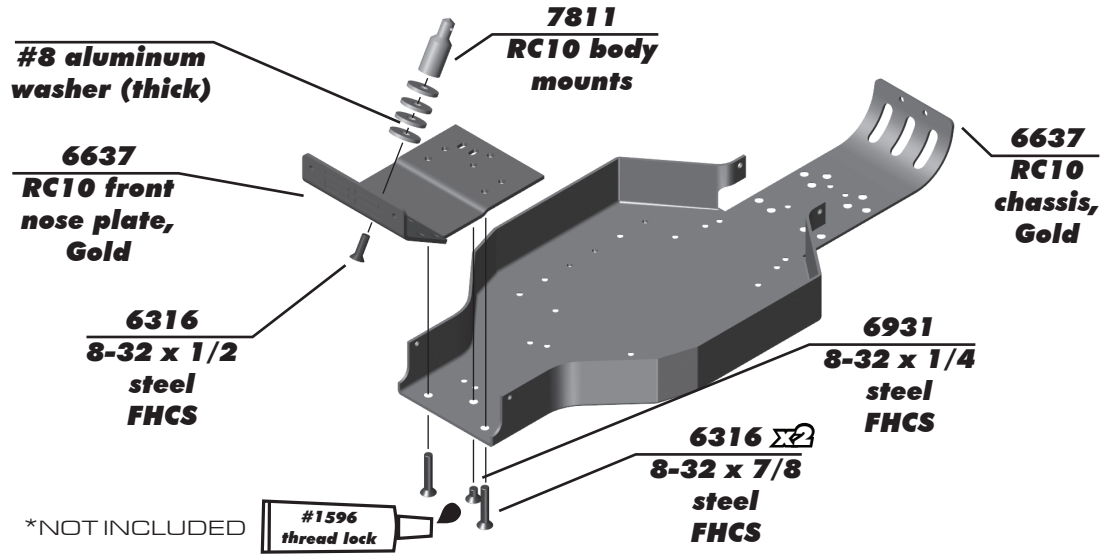

:: Nose Plate / Steering Build - Bag A - Step 2

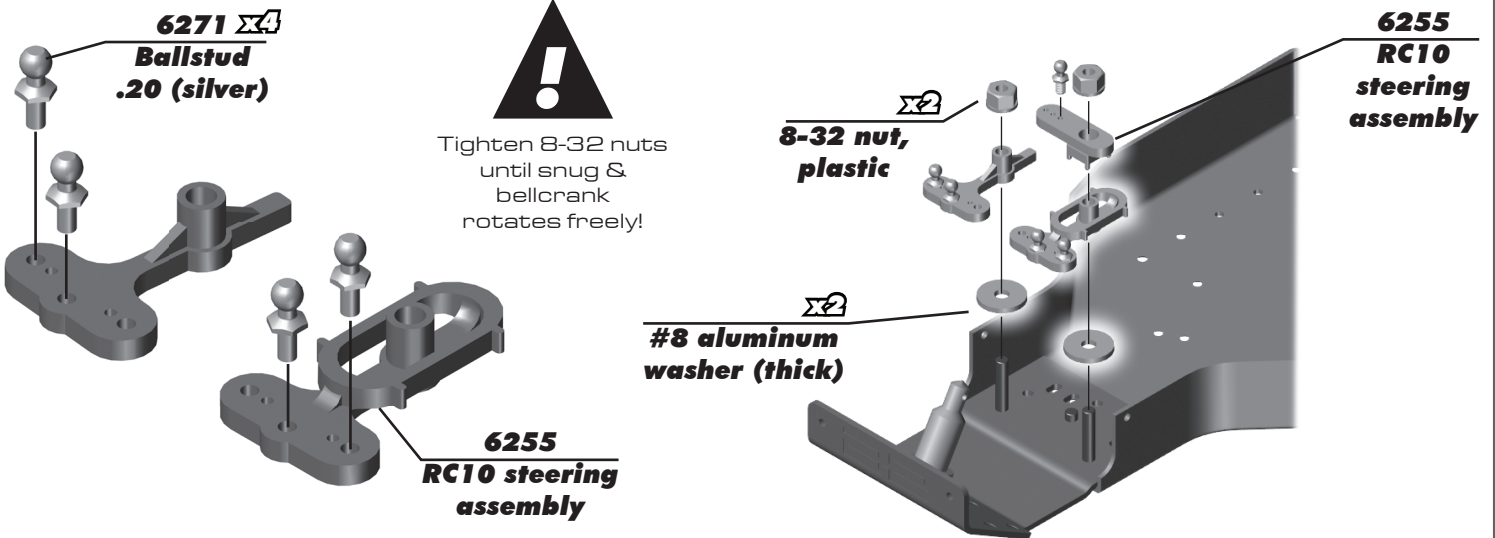

:: Front Suspension Build - Bag B - Step 1

LEFT

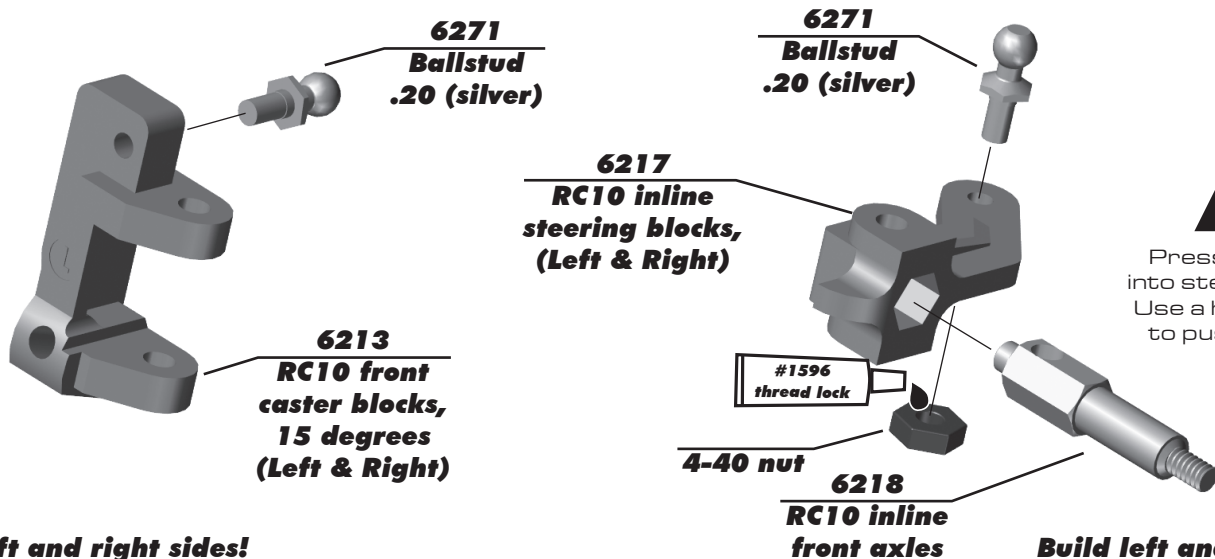

Build left and right sides!

Build left and right sides!

:: Front Suspension Build - Bag B - Step 2

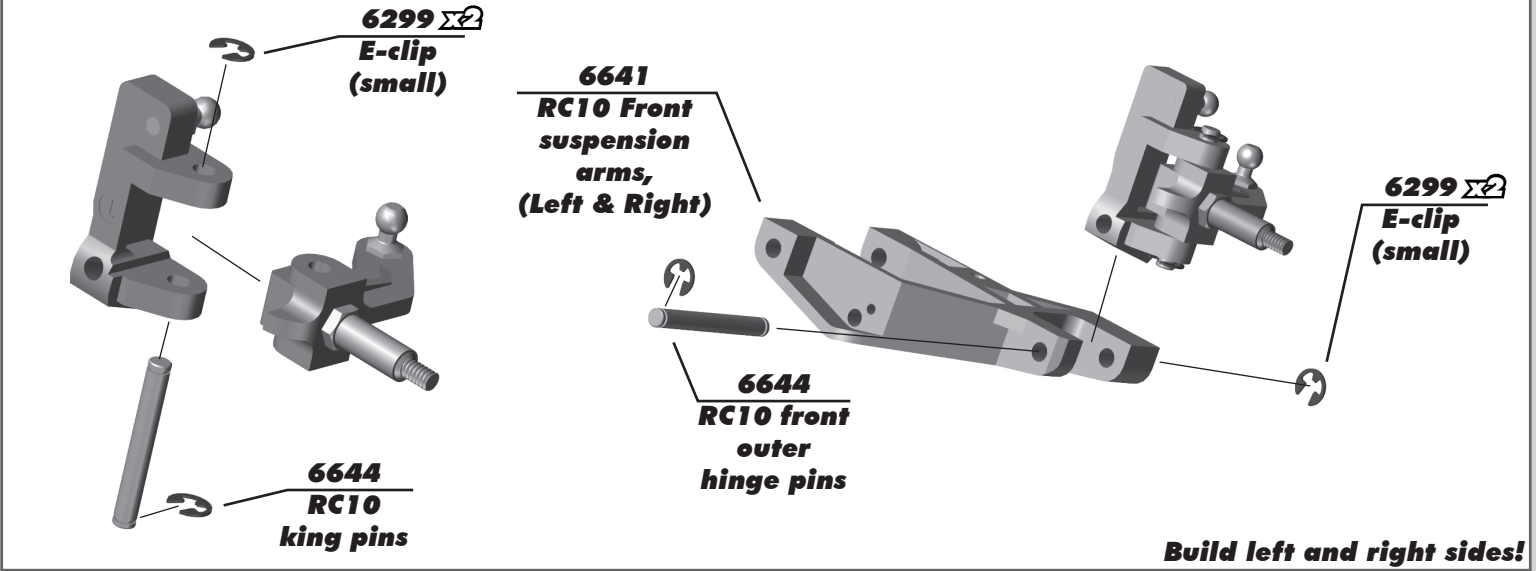

:: Front Suspension Build - Bag B - Step 3

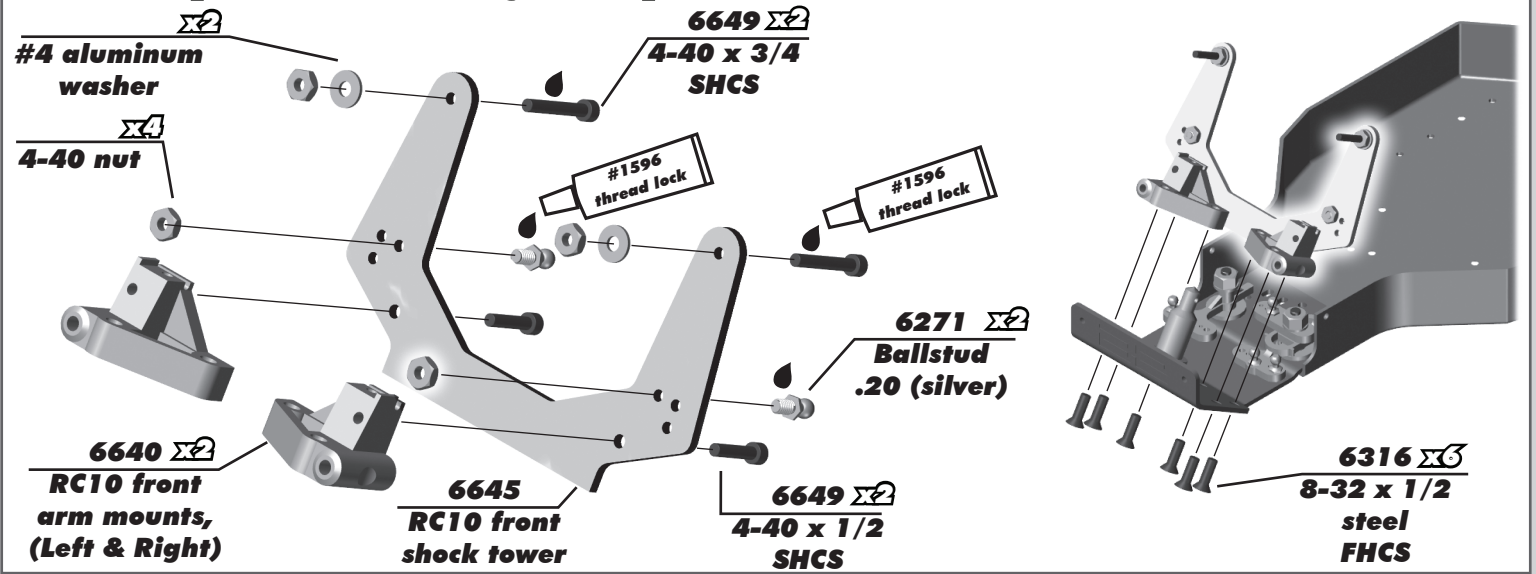

:: Front Suspension Build - Bag B - Step 4

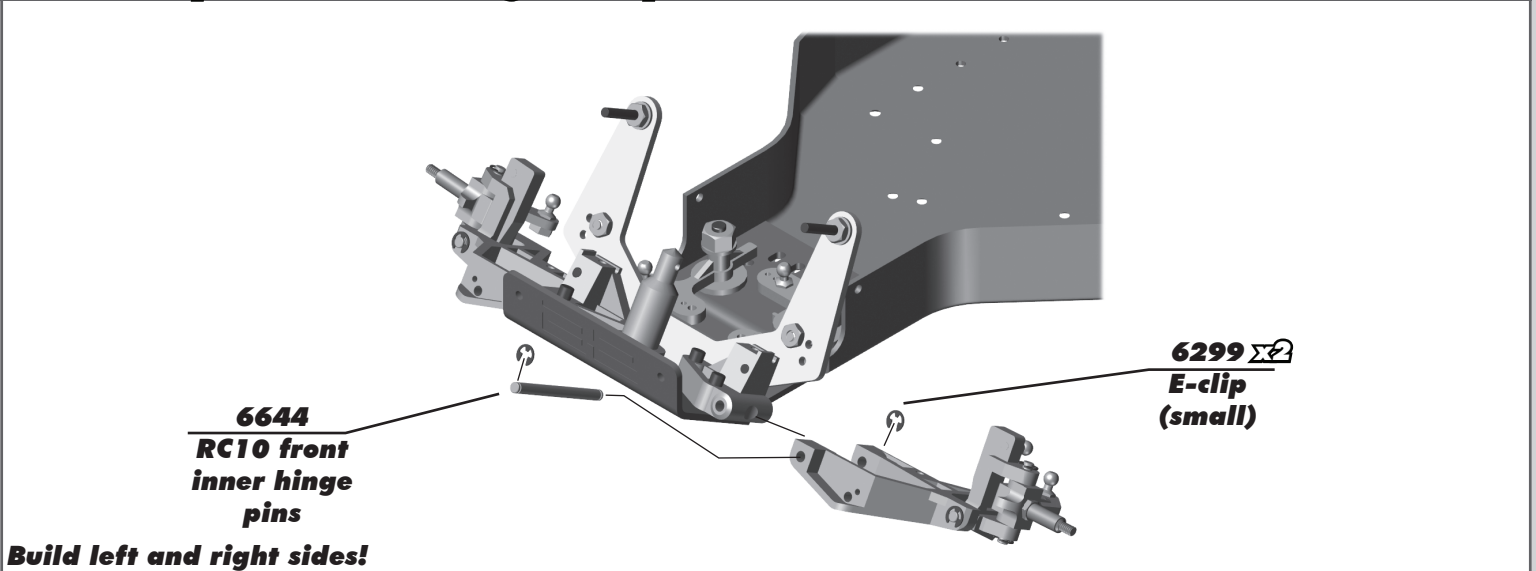

:: Transmission Build - Bag C - Step 1

6579
Diff drive rings

6578
Diff outdrives

6577
Diff thrust washers

6573
Diff thrust bolts

Build Tip:
Install the first washer (groove up), add grease #6588. Install the caged thrust washer. Add grease on top of the balls, then install the 2nd washer (grooves down).

:: Transmission Build - Bag C - Step 2

6581 $\times 12$
Carbide diff balls, 3/32"

7812
Diff gear 45T

6589 $\Sigma 2$
Bearing 5/32 x 5/16

Build Tip:
Do this entire step with the diff screw on the end of your wrench for better control.

:: Transmission Build - Bag C - Step 3

6575
Diff thrust nut

6582
Diff thrust spring

Compress spring first.

6575
Diff bolt cover

As you tighten the diff bolt, you will notice the T-nut ears moving closer to the bottom of the outdrive slot. This compresses the spring behind the T-nut. The spring should be completely compressed at the time the T-nut reaches the end of the slot.

Caution! Pay close attention to the feeling when the spring is completely compressed. Do not overtighten the bolt. When you feel the spring completely compressed, loosen the diff bolt 1/8 of a turn. Your diff should now operate smoothly but with resistance as the outdrives move in opposite directions.

After you have driven the car once, re-check the diff setting.

:: Transmission Build - Bag C - Step 4

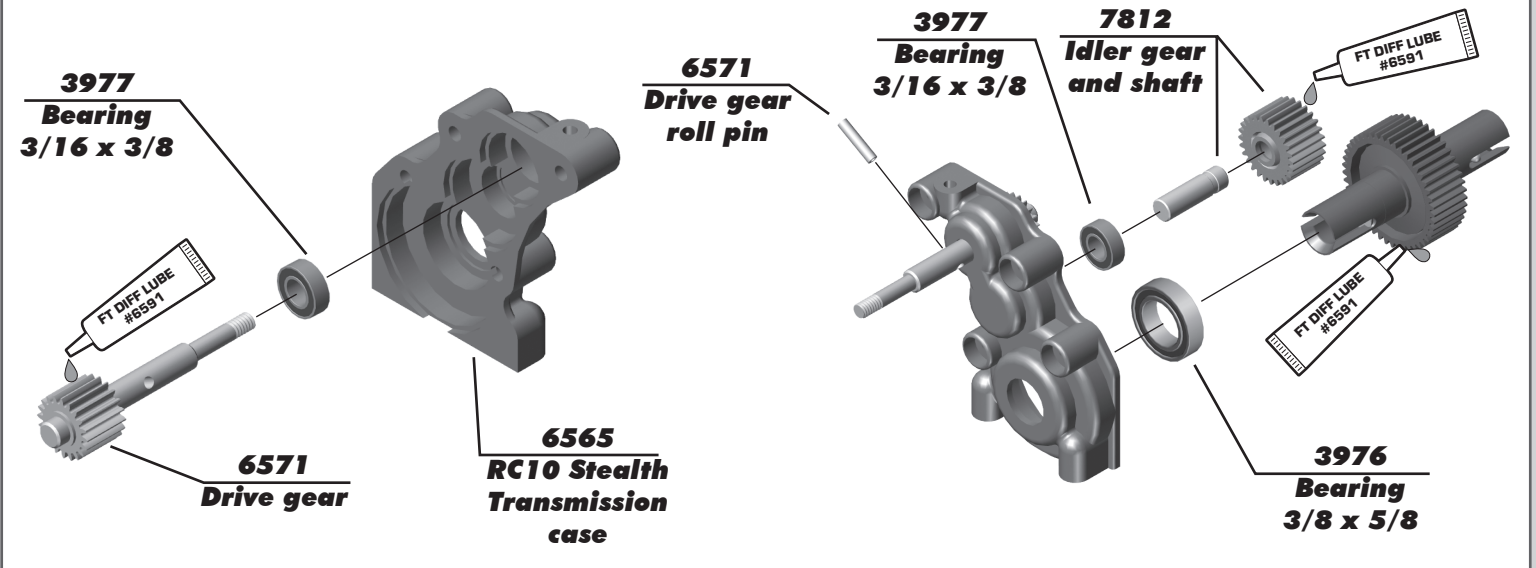

:: Transmission Build - Bag C - Step 5

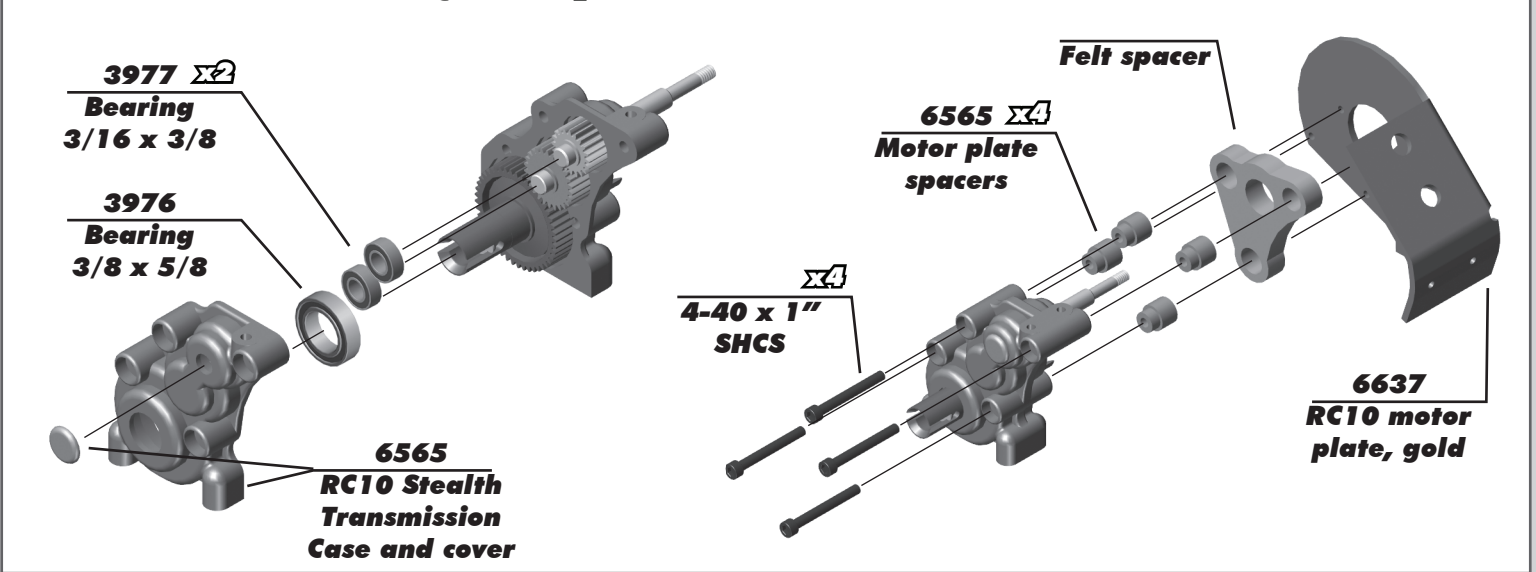

:: Transmission Build - Bag C - Step 6

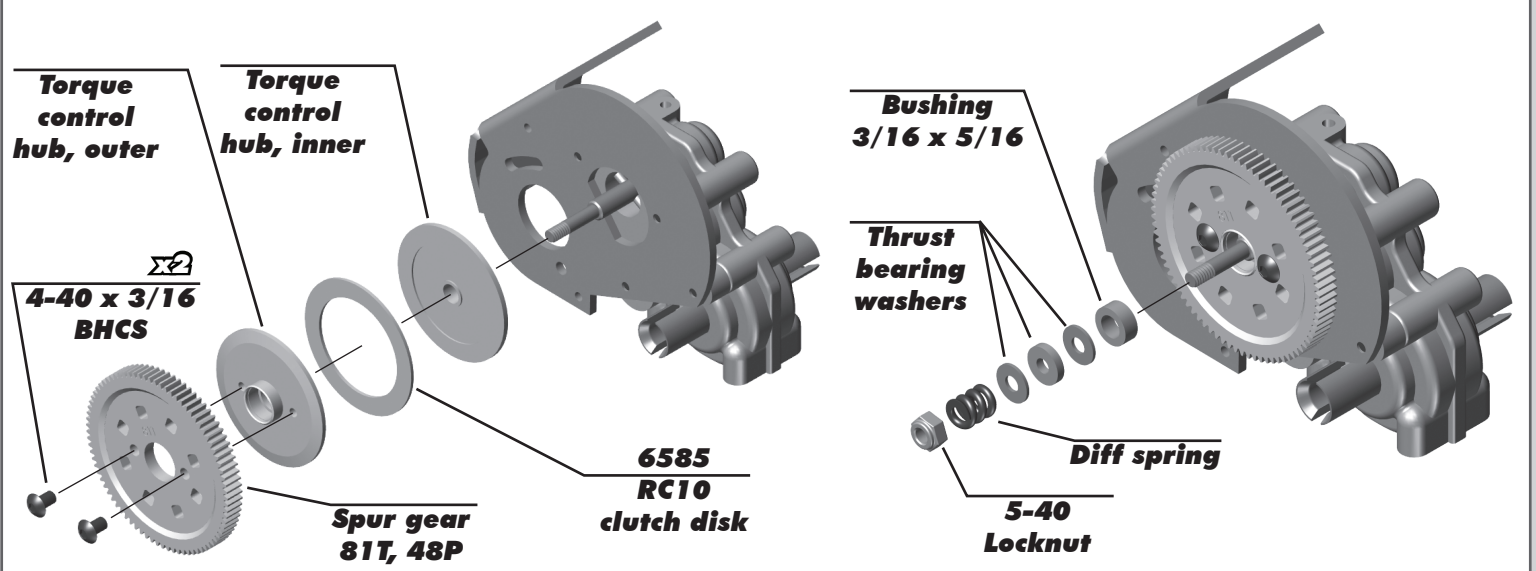

:: Rear Bulkhead Build - Bag D - Step 1

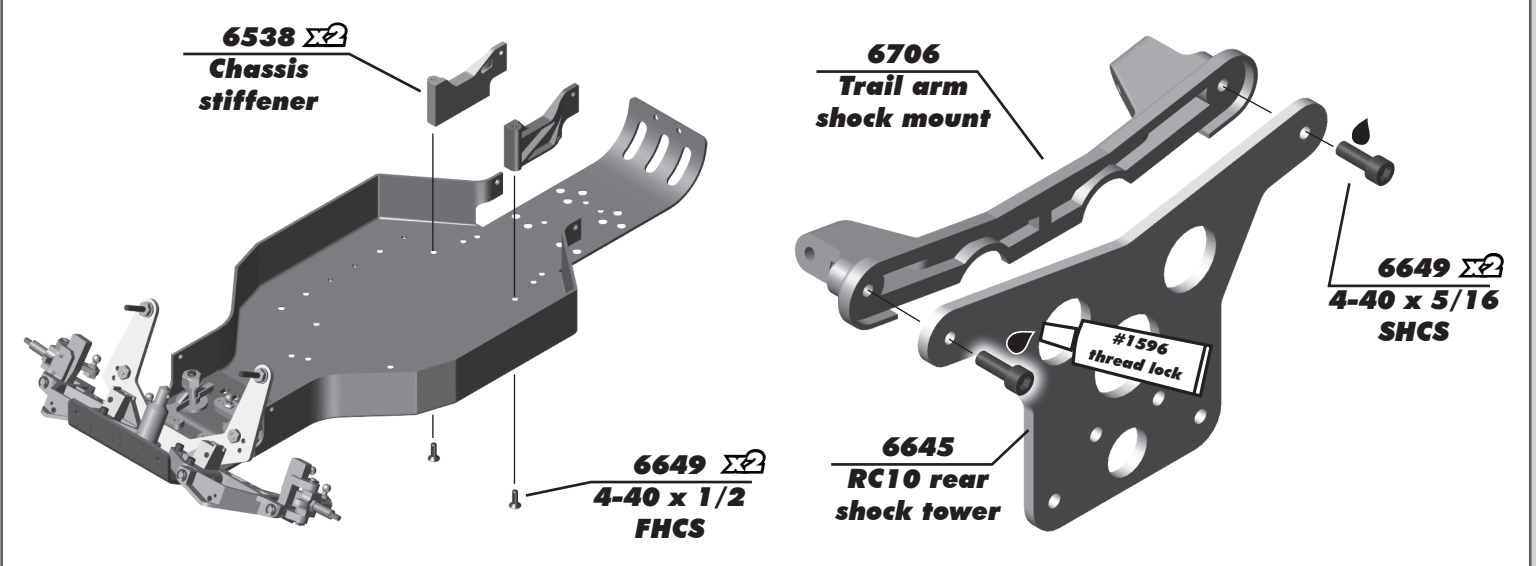

:: Rear Bulkhead Build - Bag D - Step 2

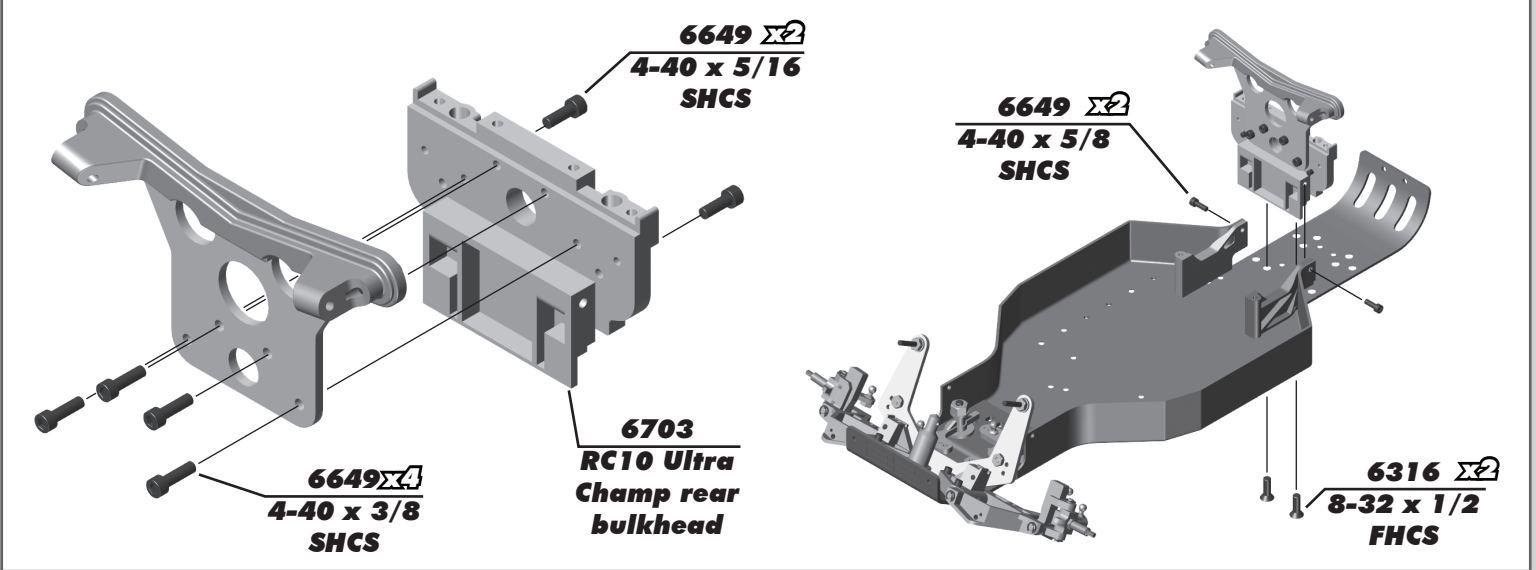

:: Rear Bulkhead Build - Bag D - Step 3

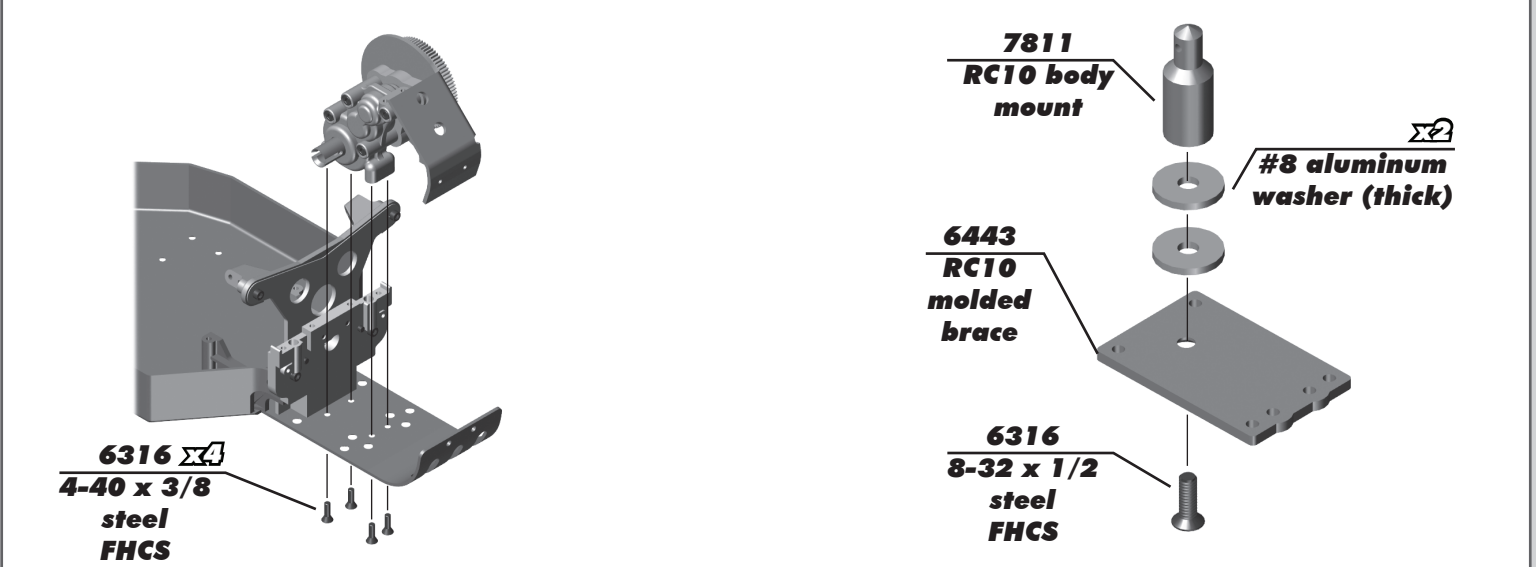

:: Rear Bulkhead Build - Bag D - Step 4

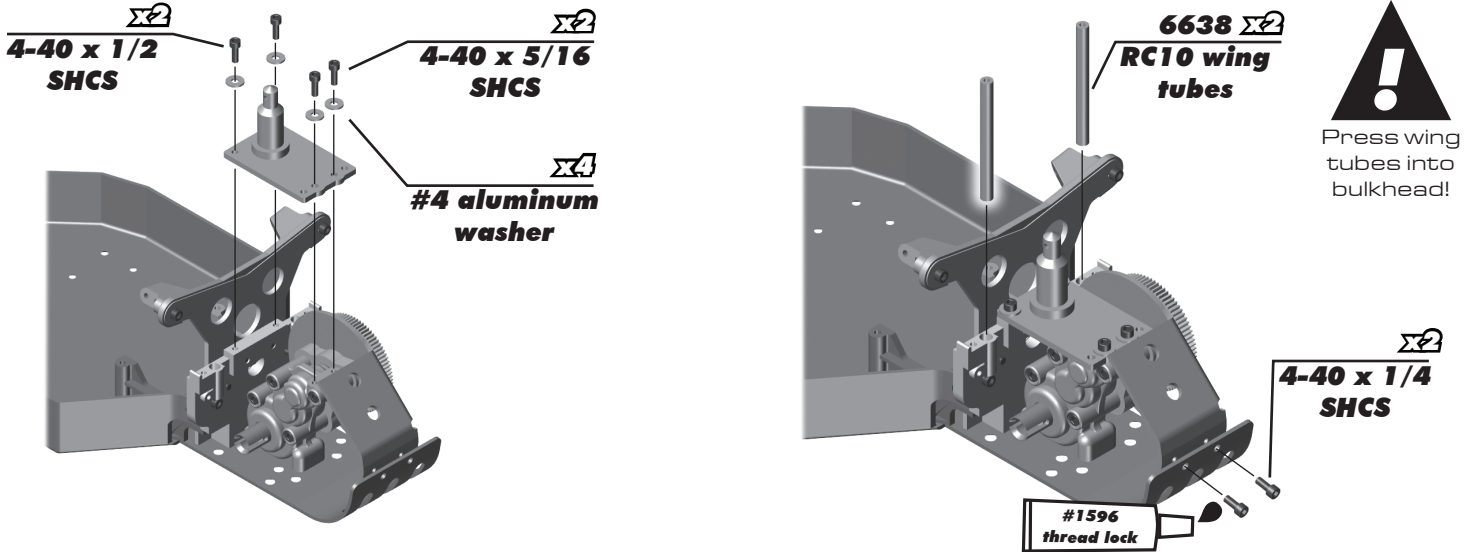

:: Rear Suspension and Sides Build - Bag E - Step 1

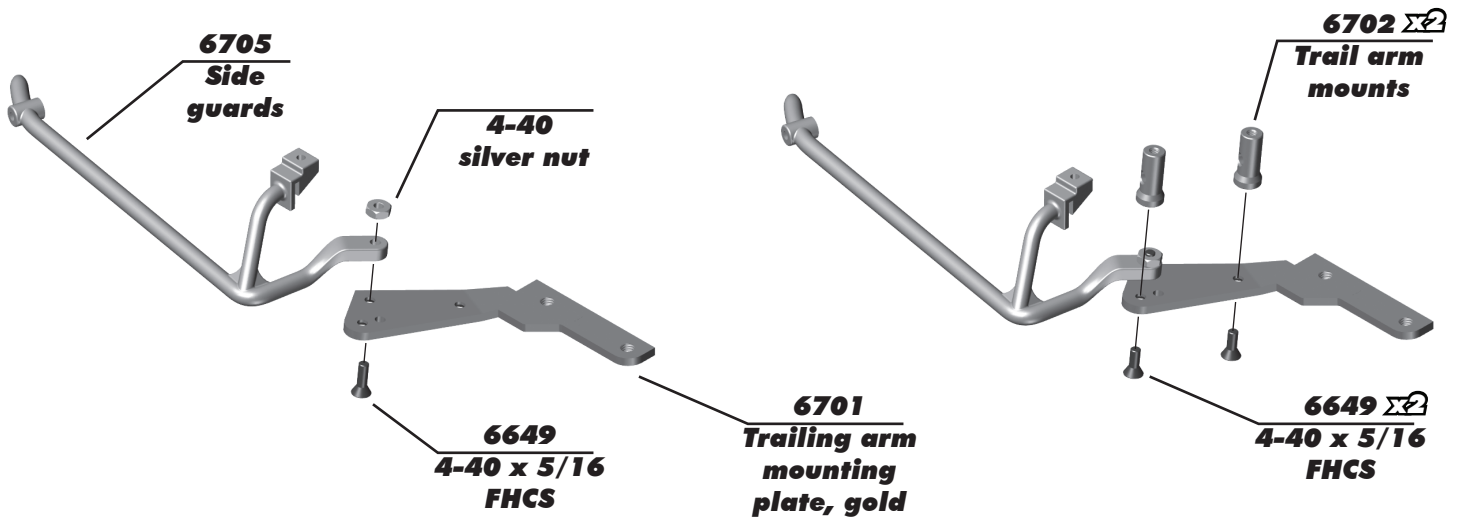

Build left and right sides!

:: Rear Suspension and Sides Build - Bag E - Step 2

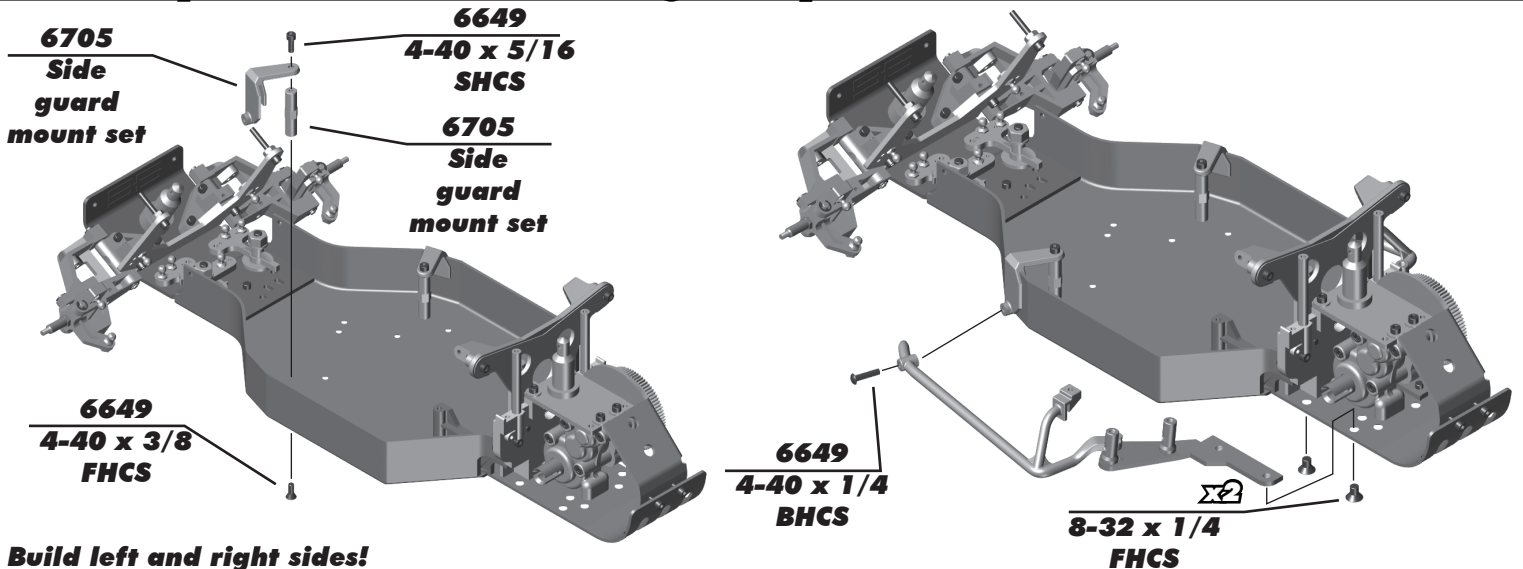

Build left and right sides!

:: Rear Suspension and Sides Build - Bag E - Step 3

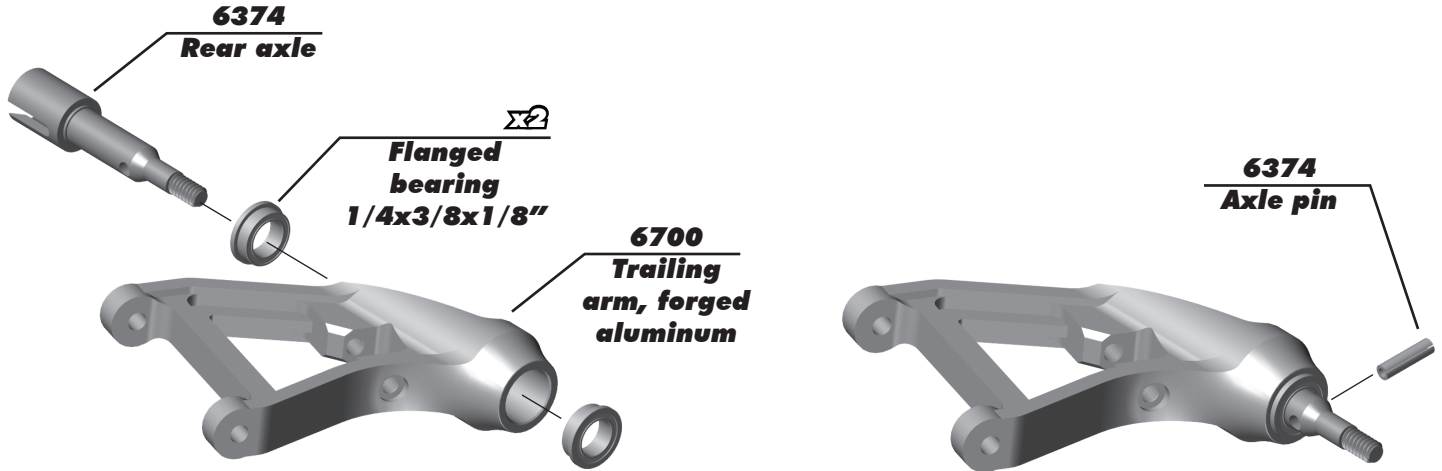

Build left and right sides!

:: Rear Suspension and Sides Build - Bag E - Step 4

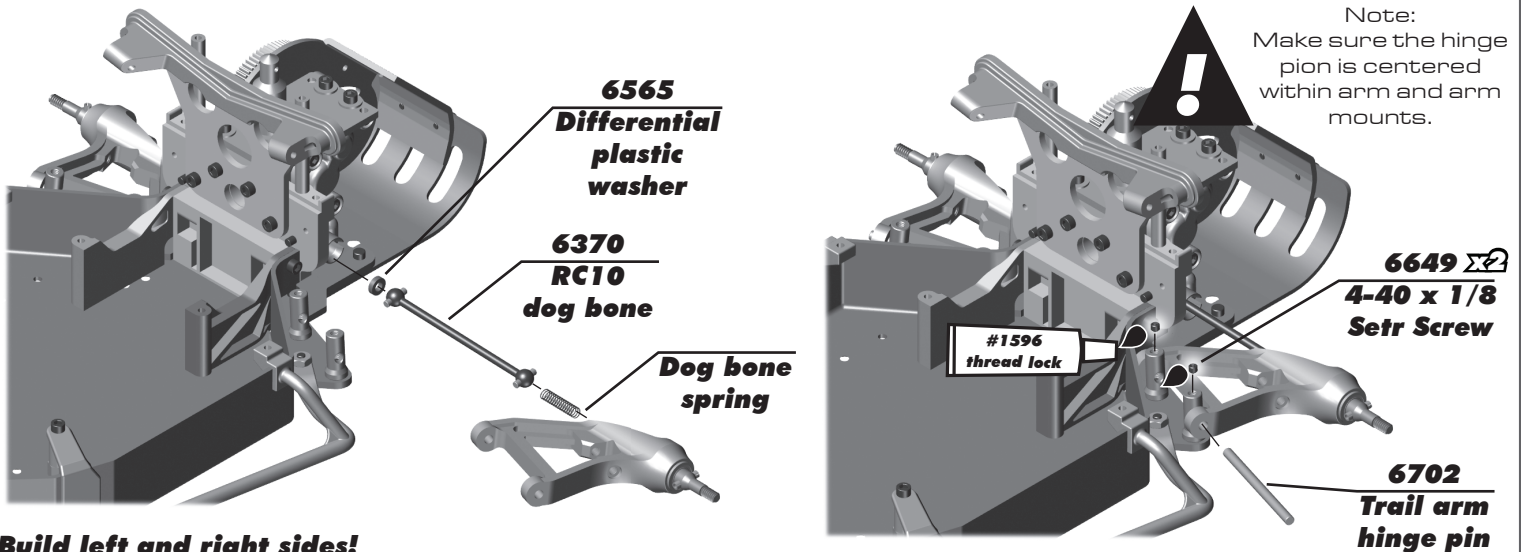

Build left and right sides!

:: Rear Suspension and Sides Build - Bag E - Step 5

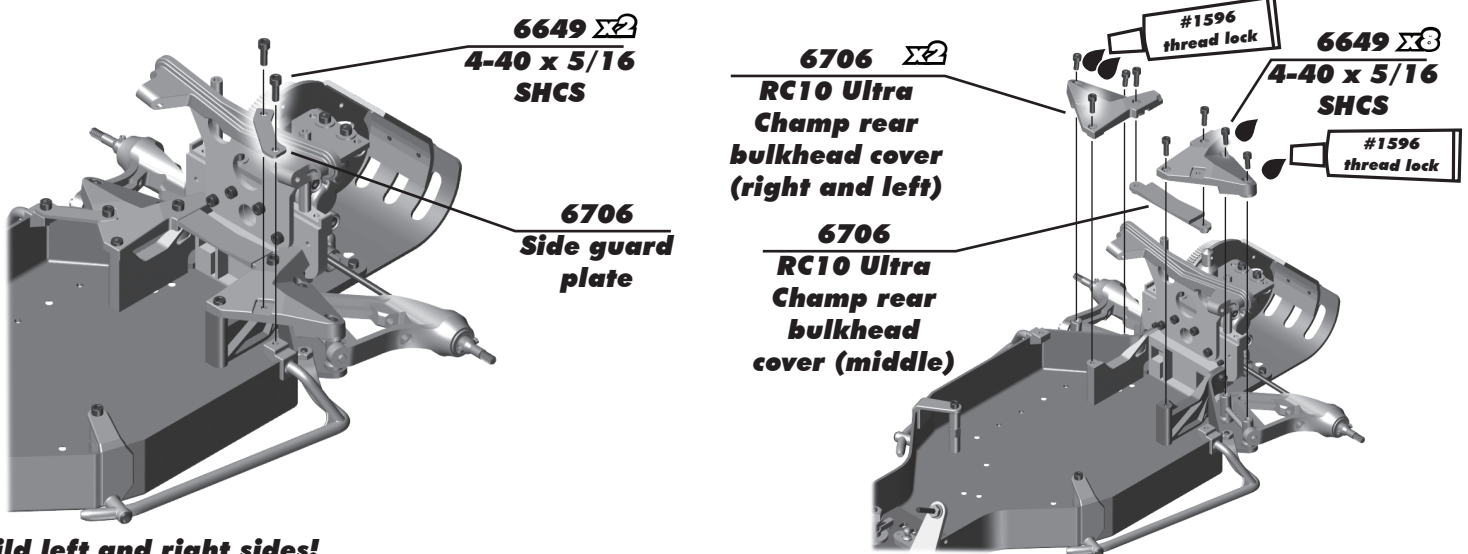

Build left and right sides!

:: Turnbuckles Build - Bag F - Step 1

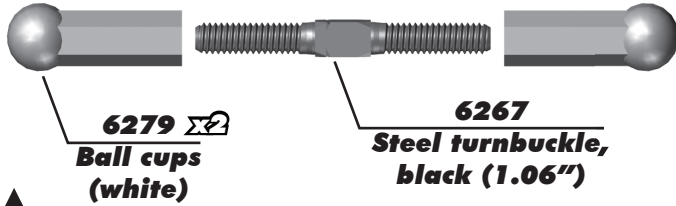

Orient the notch to the left throughout the car. It indicates which end has the left hand threads!

**Steering Rack Turnbuckle
0.50" (12.5mm)**

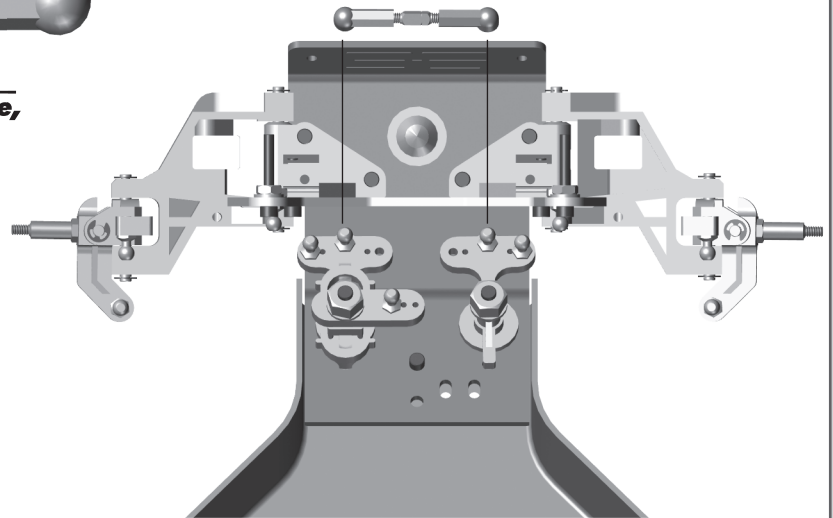

:: Turnbuckles Build - Bag F - Step 2

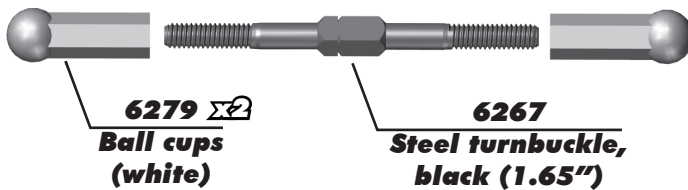

Orient the notch to the left throughout the car. It indicates which end has the left hand threads!

**Front Camber Turnbuckle
1.14" (29.00mm)**

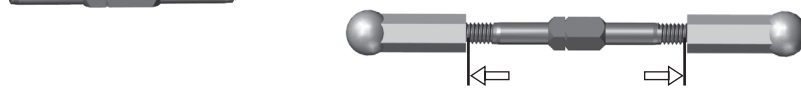

Recommended turnbuckle lengths are approximate. Final recommended settings = 0 degree Front Toe in and -2 Degree Camber Front and Rear.

Build left and right sides!

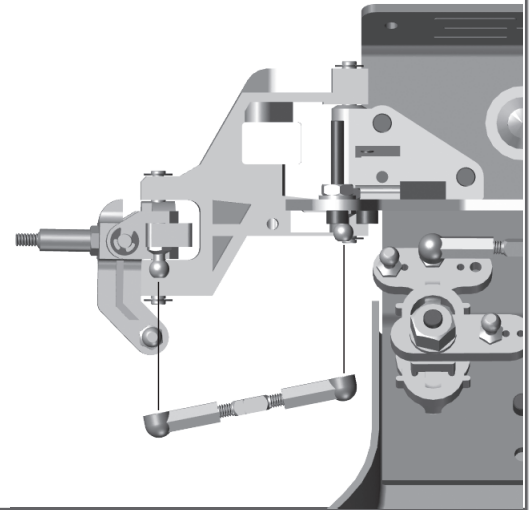

:: Shocks Build - Bag G - Step 3

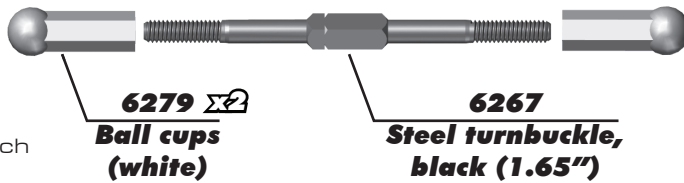

Orient the notch to the left throughout the car. It indicates which end has the left hand threads!

**Steering Turnbuckle
1.37" (35.00mm)**

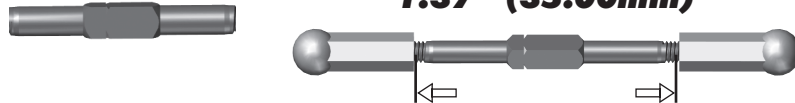

Recommended turnbuckle lengths are approximate. Final recommended settings = 0 degree Front Toe in and -2 Degree Camber Front and Rear.

Build left and right sides!

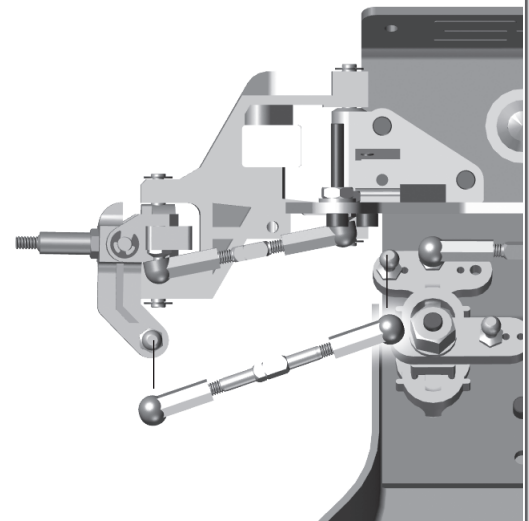

:: Shocks Build - Bag G - Step 1

Remove spurs

Piston

Piston number here
Use #2 = front shocks
Use #2 = rear shocks

TIP: Use marker to mark the piston numbers for easy identification!

6299 E-clip (small)

6460 Shock shaft, front (0.71)

6420 Shock shaft, rear (1.32)

6420/6462 Shock pistons (1, 2, 3)

6299 E-clip (small)

Build two front and two rear!

:: Shocks Build - Bag G - Step 2

5407 Σ 2 Red o-ring

Remove spurs

Shock assembly tool

6420/6462 Σ 2 Off-road shock rebuild kit

6437 FT Hard Anodized shock body, front (0.71)

6435 FT Hard Anodized shock body, rear (1.32)

Shock fluid 30wt #5422

SNAP!

SNAP!

Front Shock

Rear Shock

Place on table and push down hard until clamp snaps into place

:: Shocks Build - Bag G - Step 3

Front Shock

Rear Shock

6420/6462 Σ 2 Shock downstops

6420/6462 Shock cap o-ring

6420/6462 Shock pivot ball

6420/6462 Shock rod end

Build two front and two rear!

:: Shocks Build - Bag G - Step 4

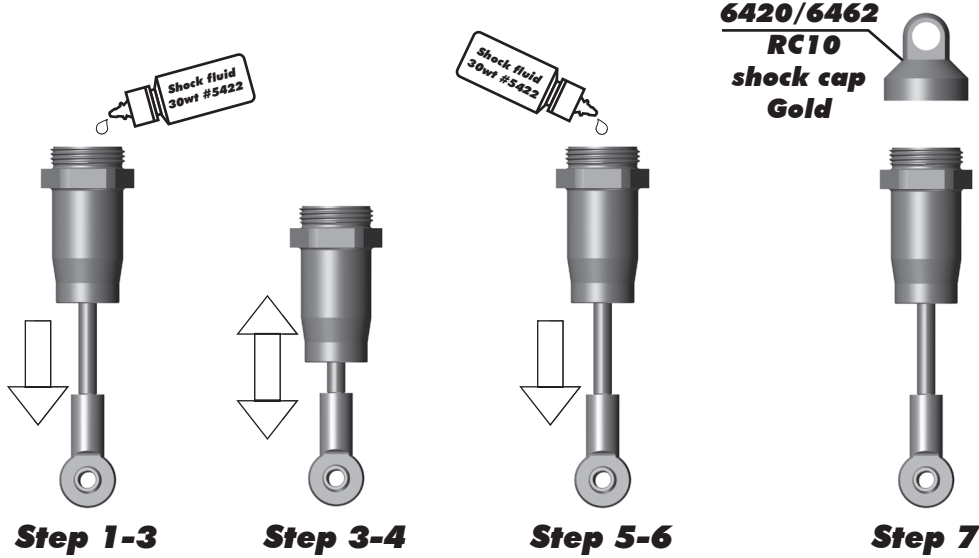

* Shock Bleeding Steps:

1. Pull shock shaft down.
2. Fill shock body 3/4 full with silicone fluid.
3. Slowly move the shock shaft up and down to remove air from under piston.
4. Wait for bubbles to come to surface.
5. Fill shock body to top with silicone fluid.
6. Place several drops of oil in the cap and on cap threads.
7. Install cap and tighten completely.
8. Slowly compress shaft all the way to the top. If there is pressure at the top of the stroke, there is too much oil. You must bleed it out.
9. Slowly pull shaft down.
10. Unscrew the cap 3/4 turn and tilt the shock at a slight angle.
11. Slowly compress the shaft to push out excess oil and air. You should see bubbles coming out from under the cap.
12. With the shaft compressed, tighten the cap and re-check for pressure at the top of the stroke. If there is still pressure, repeat steps 9 thru 11.

:: Shocks Build - Bag G - Step 5

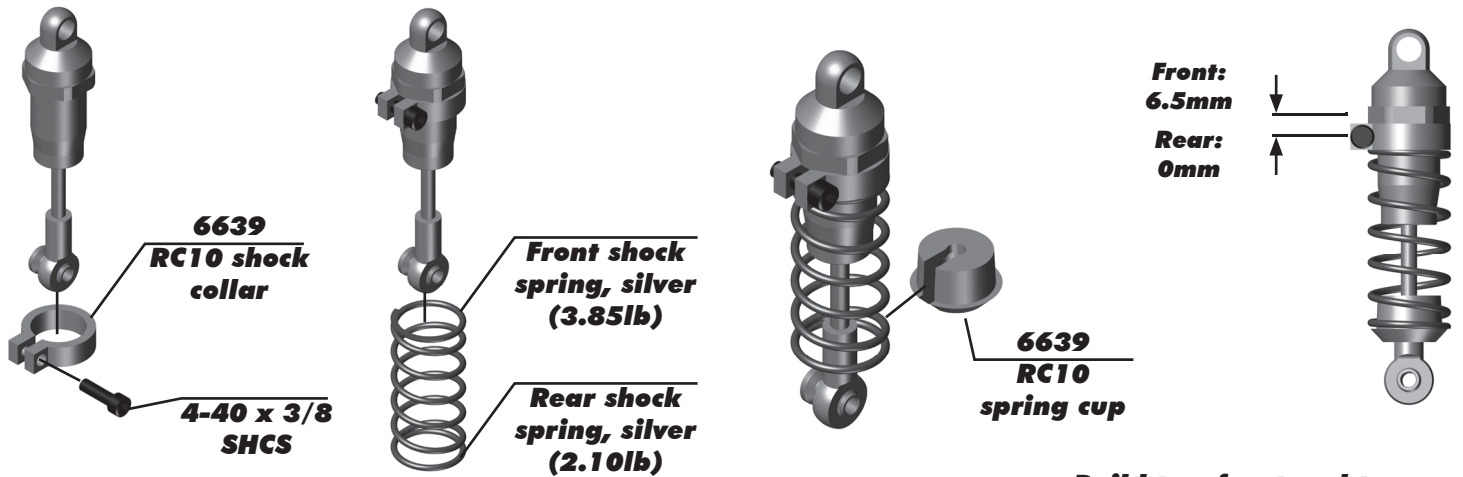

Build two front and two rear!

:: Shocks Build - Bag G - Step 6

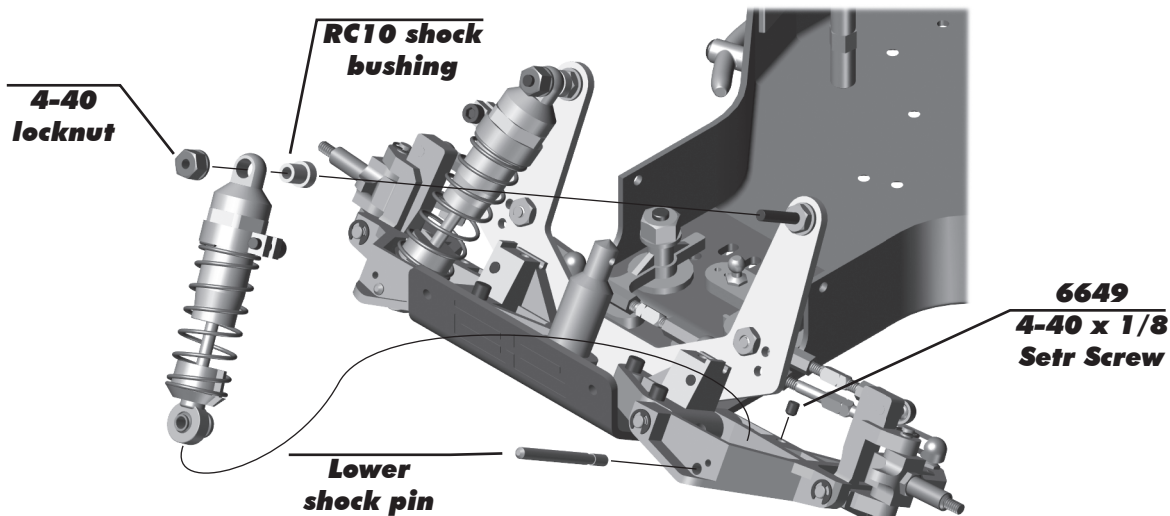

Build left and right sides!

:: Shocks Build - Bag G - Step 7

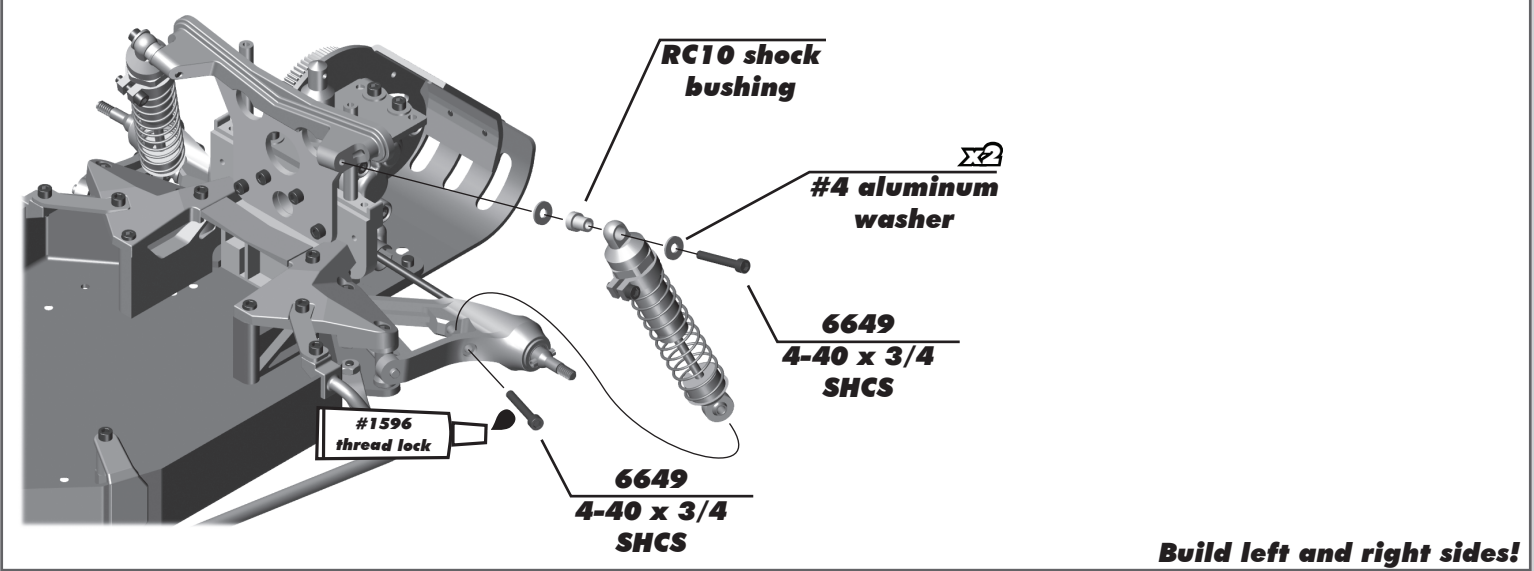

:: Chassis Build - Bag H - Step 1

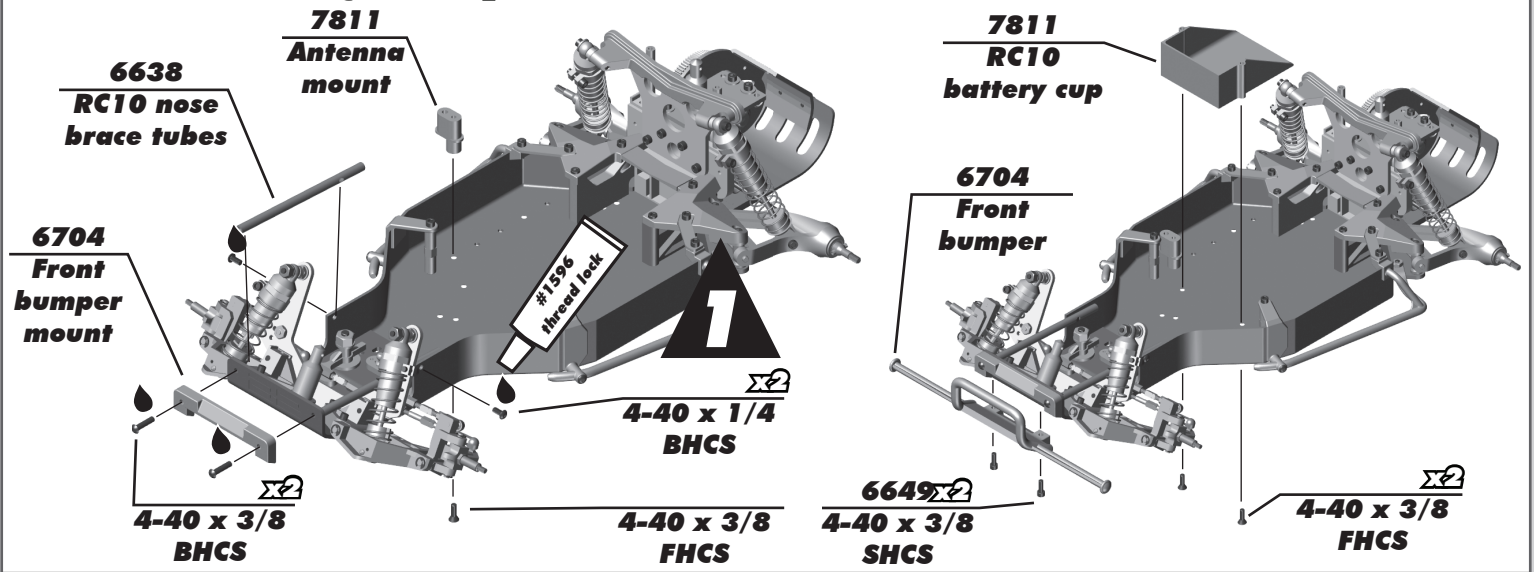

:: Chassis Build - Bag H - Step 2

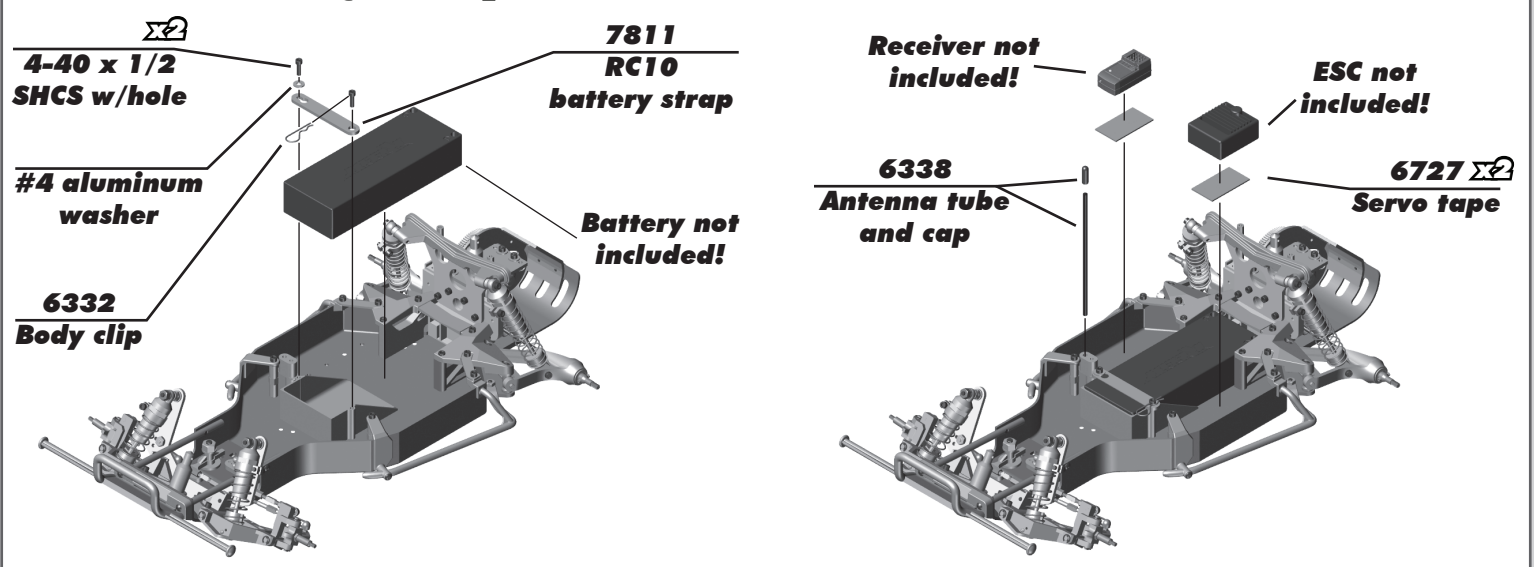

:: Steering Servo Build - Bag I - Step 1

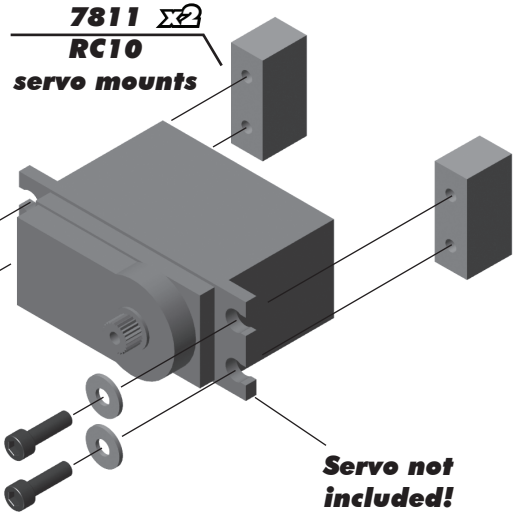
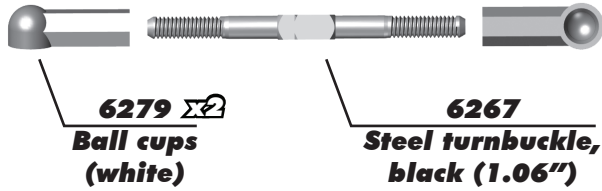

:: Steering Servo Build - Bag I - Step 2

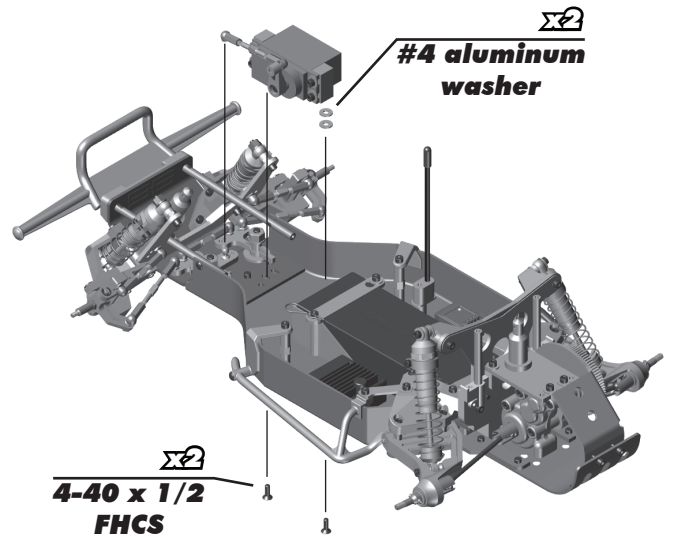
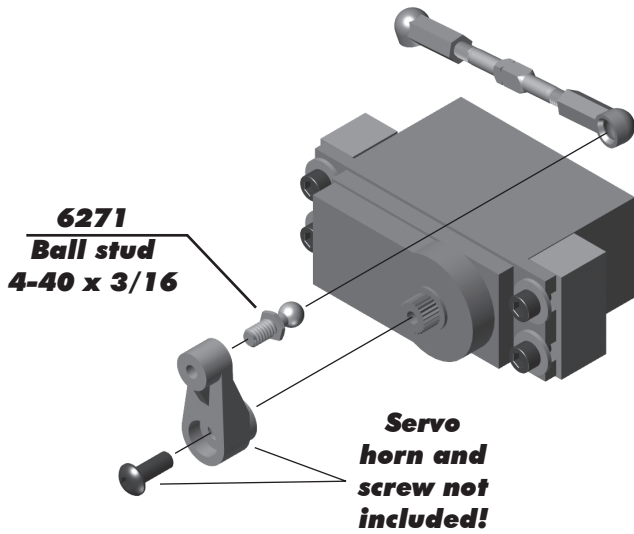

:: Wheels Tires, Body, and Accessories Build - Bag J - Step 1

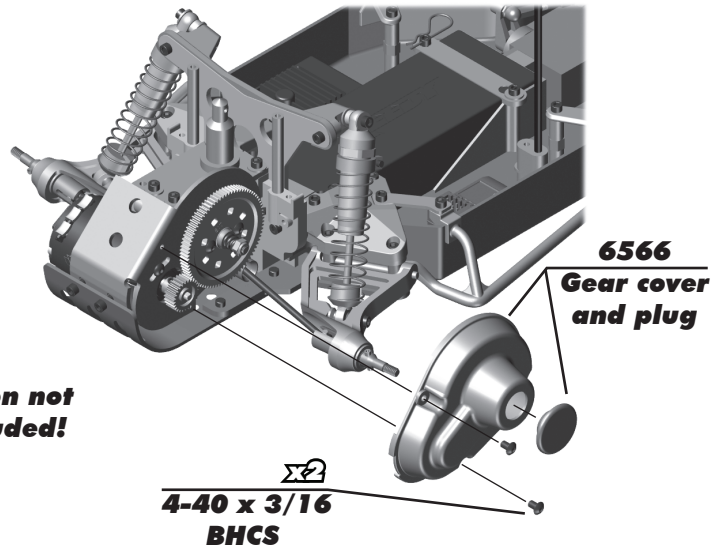
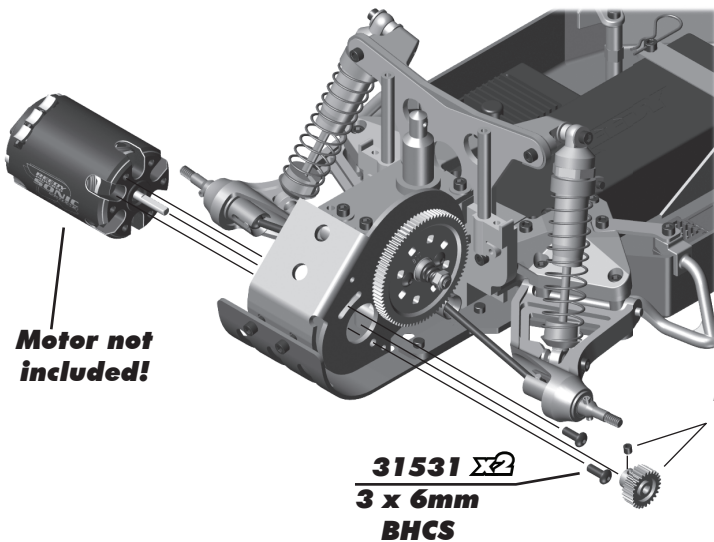

:: Wheels Tires, Body, and Accessories Build - Bag J - Step 2

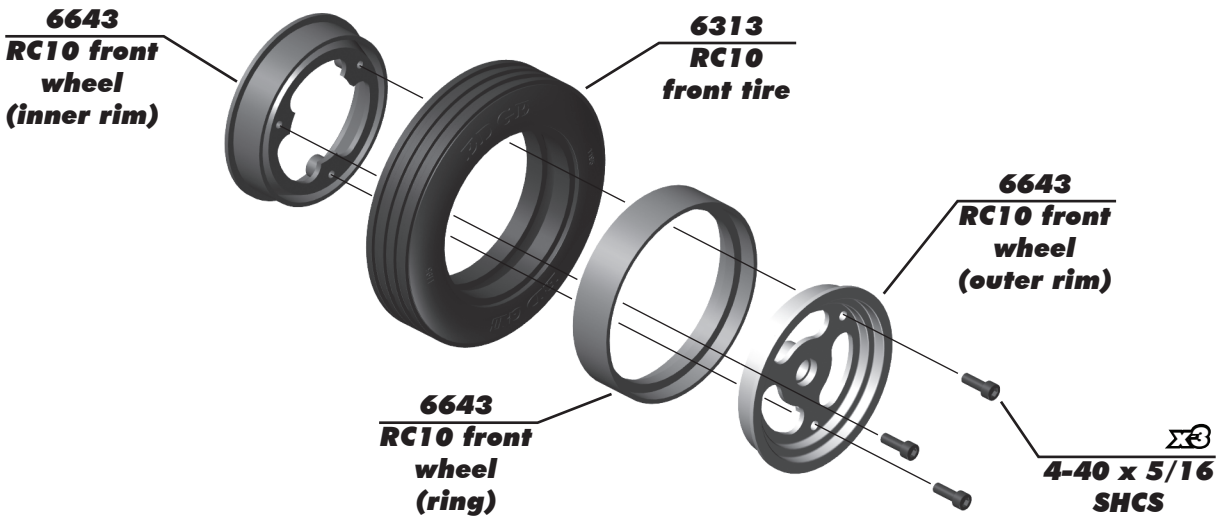

Build 2

:: Wheels Tires, Body, and Accessories Build - Bag J - Step 3

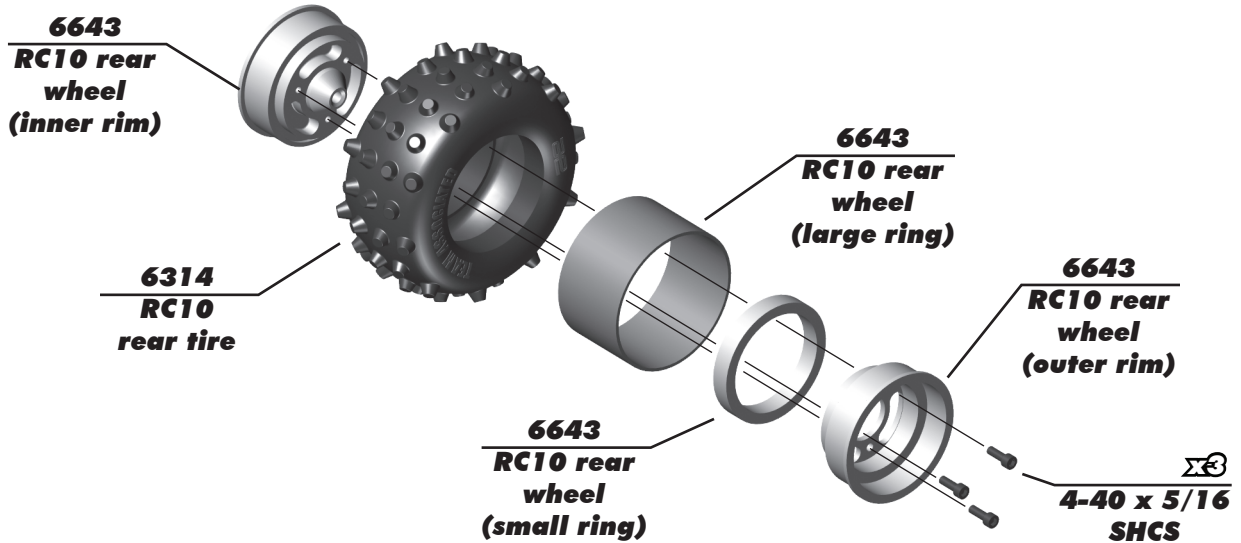

Build 2

:: Wheels Tires, Body, and Accessories Build - Bag J - Step 4

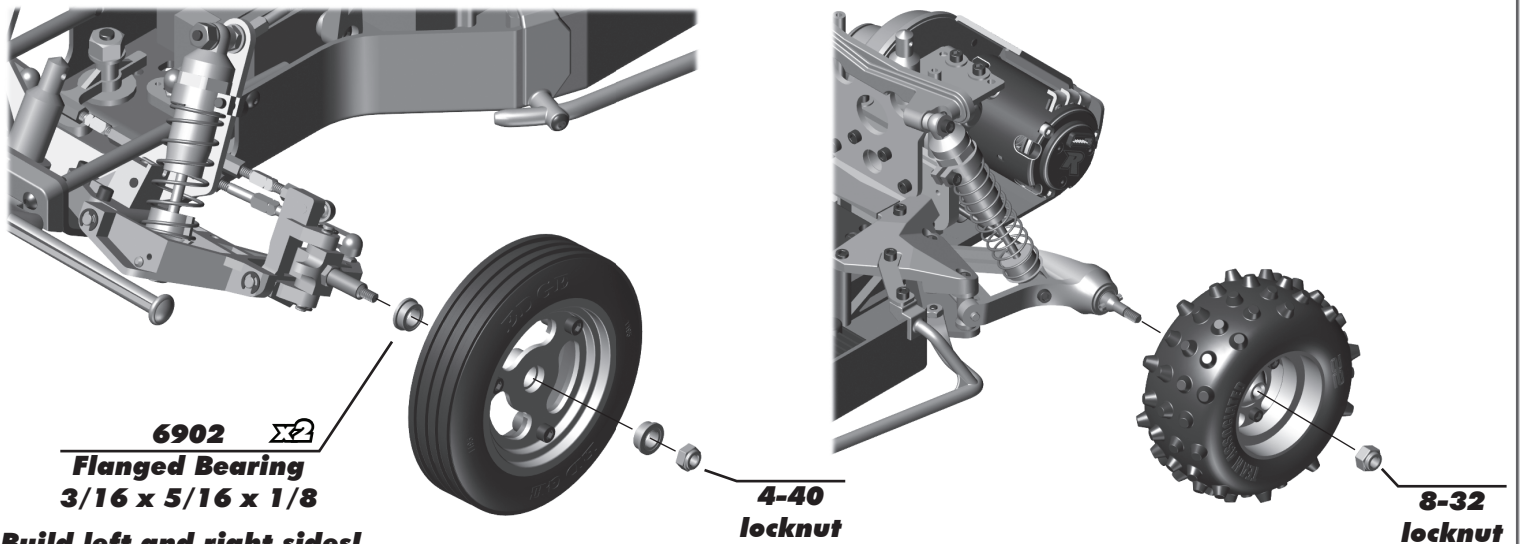

:: Wheels Tires, Body, and Accessories Build - Bag J - Step 5

Painting Tips:

Your RC 10 Kit comes with a clear polycarbonate body and wing. You will need to prep the body and wing before you can paint them. Wash the inside thoroughly with warm water and liquid detergent. Dry the body and wing using a clean, soft, lint-free cloth. Use high quality masking tape to make masks for the windows and install them on the inside of the body (RC cars get painted from the inside). Using high quality masking tape, apply tape to the inside of the body to create a design. Spray (either rattle can or airbrush R/C specific paint) the paint to the inside of the body (preferably dark colors first, lighter colors last).

NOTE: use ONLY paint that is recommended for use with (polycarbonate) plastics. If you do not, you can destroy the plastic body and wing!!!!). It is recommended to wear a mask while painting.

After the paint has dried, cut the body and wing along the trim lines. Make sure to drill or use a body reamer to make the holes for the body mounts, wing mounts, and antenna!

**6159
RC10 Protec
Buggy body,
unpainted**

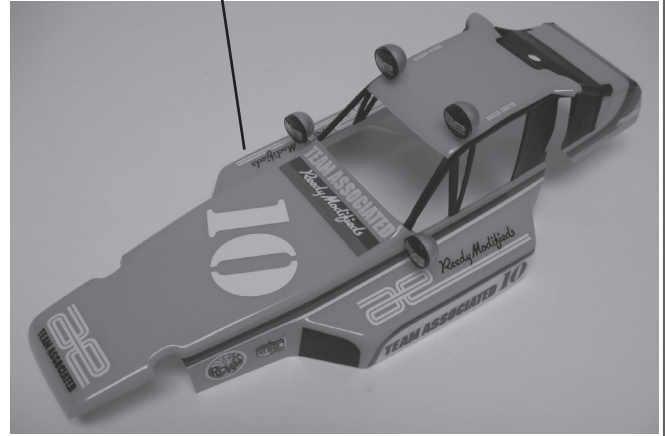

:: Wheels Tires, Body, and Accessories Build - Bag J - Step 6

Light Buckets:

Press the light bucket halves together. Install light buckets with 2-56 x 3/16 SHCS in areas shown.

**6639
Light
buckets**
x4
**2-56 x 3/16
SHCS**

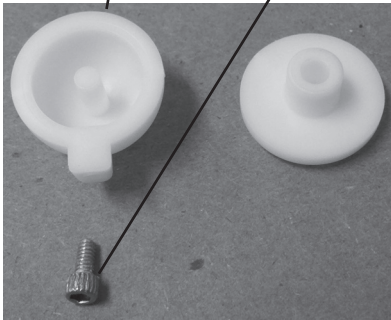

Mount the light buckets in any location of your choosing, or not at all.



:: Wheels Tires, Body, and Accessories Build - Bag J - Step 7

Painting Tips:

Driver :
Your RC 10 Kit comes with a clear polycarbonate driver figure. You will need to prep the driver figure before you can paint it. Wash the inside and outside thoroughly with warm water and liquid detergent. Dry the driver figure using a clean, soft, lint-free cloth. The driver figure can be painted from the inside or the outside, depending on what type of finish you would like. If painted from the inside, the painted sections will appear glossy. If painted on the outside, the painted sections will appear flat or matte finished. Trim as shown and install inside the body using strapping tape. After painting, cut the body and wing along the trim lines.

NOTE: use ONLY paint that is recommended for use with (polycarbonate) plastics. If you don't, you can destroy the plastic body, driver figure, and wing!!!!.

**RC10 driver
figure, clear**



:: Wheels Tires, Body, and Accessories Build - Bag J - Step 8

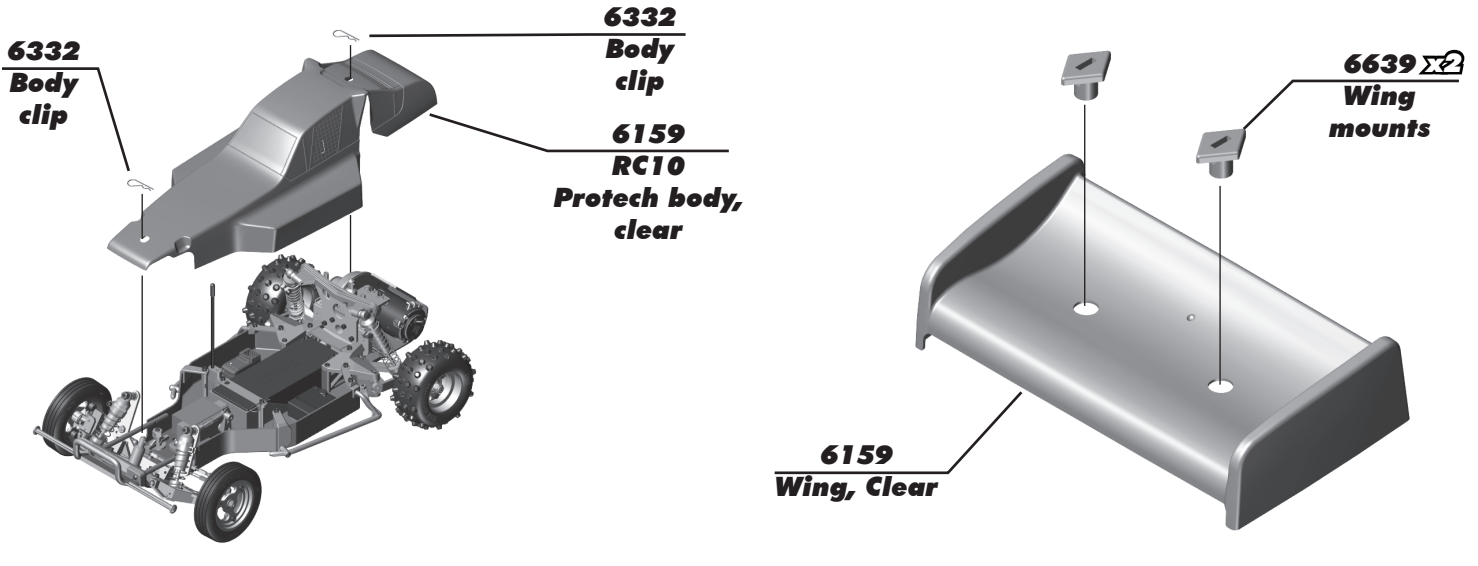

:: Wheels Tires, Body, and Accessories Build - Bag J - Step 9

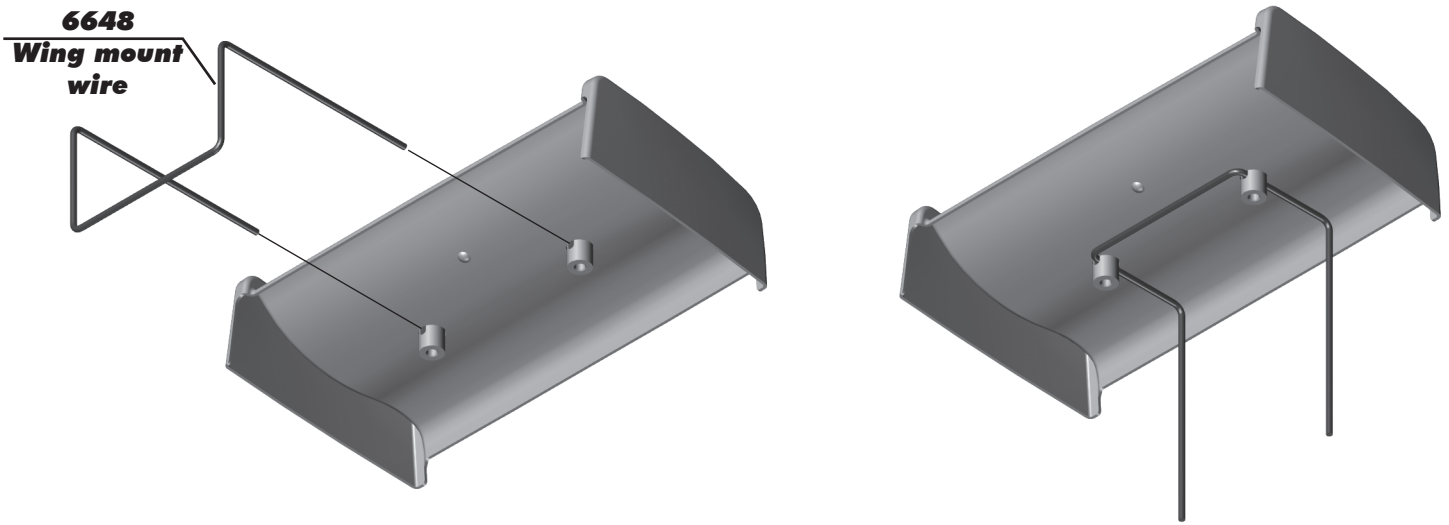

:: Wheels Tires, Body, and Accessories Build - Bag J - Step 10

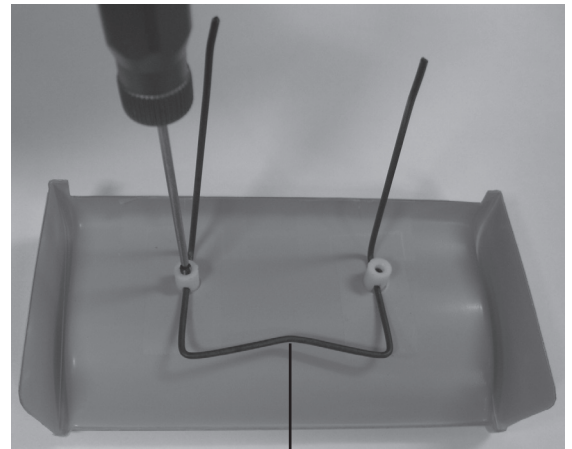
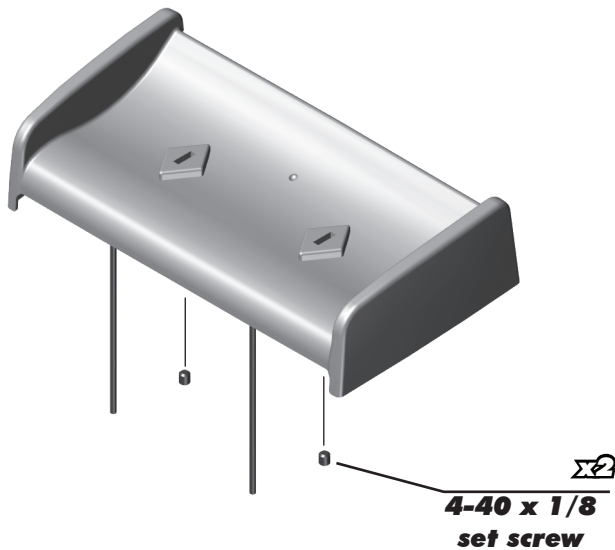

TIP: Bending the wire as shown can help ensure the wing buttons are parallel.

:: Wheels Tires, Body, and Accessories Build - Bag J - Step 11

TIP: Bend wire to create tight fit inside wing tubes.

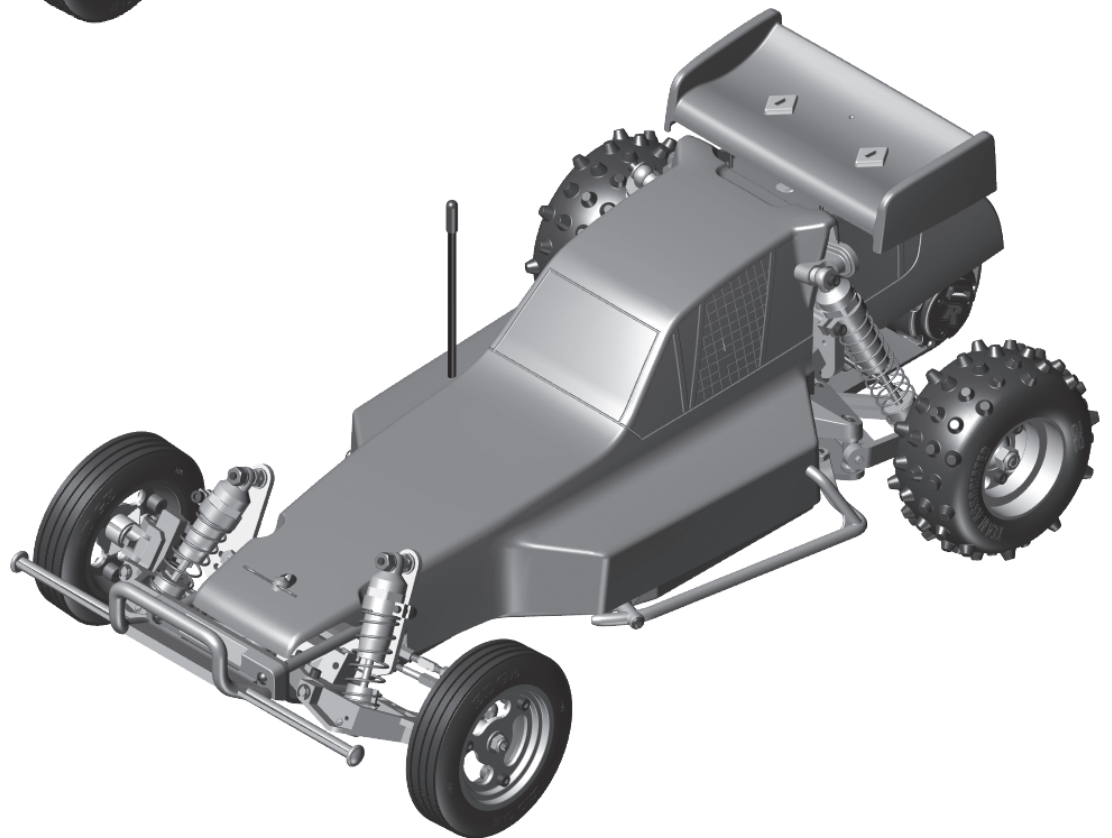
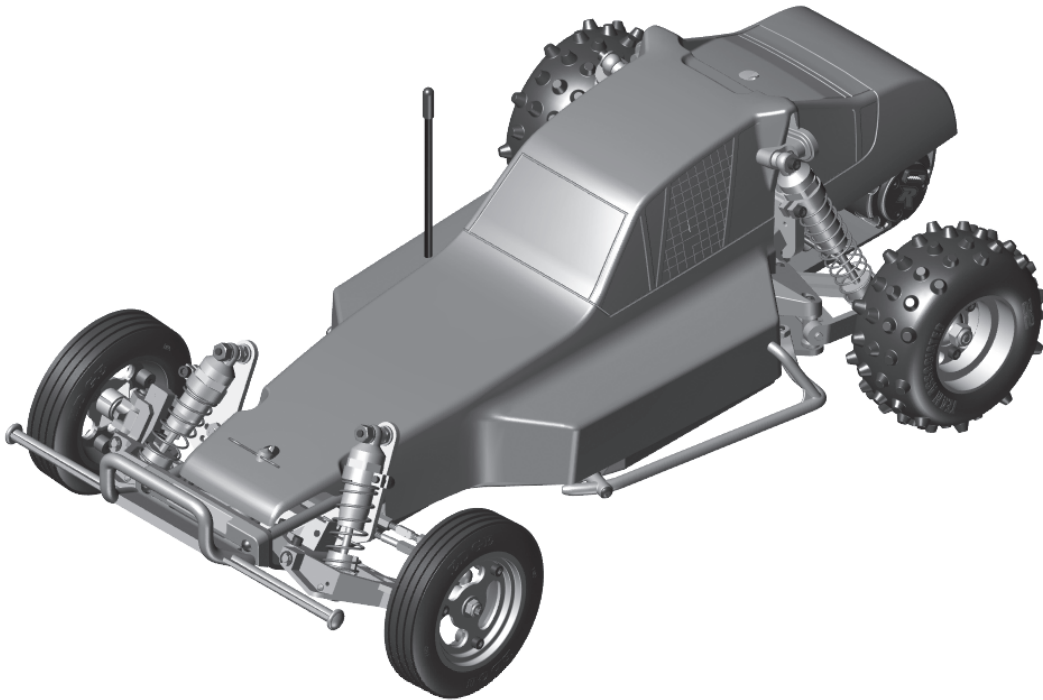
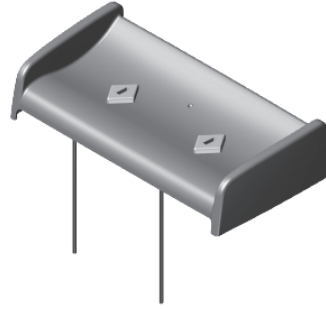

:: Notes

A large, empty rectangular area intended for taking notes, framed by a thin black border.



Associated Electrics, Inc.
21062 Bake Parkway Lake Forest, CA 92630 USA

call: (949) 544-7500 - fax: (949) 544-7501
Check out the following web sites for all of our kits, current products,
new releases, setup help, tips, and racing info!
www.AssociatedElectrics.com

FOLLOW US ON SOCIAL MEDIA



TeamAssociated
ReedyPower
ElementRC
FactoryTeam51



@TeamAssociatedRC
@ReedyPower
@Element_RC
@FactoryTeam_RC



@Team_Associated
@ReedyPower



@Associated_Electrics



TeamAssociatedRC
ElementRC



TeamAssociated
Reedy
Element-rc