

HUSKY 1800mm



AH011PV - Husky - Instruction Manual

Instruction manual

Warning:

This manual contains important information that will help you maintain and operate your model aircraft in a reliable and safe manner. Please read the instructions and warnings carefully prior to assembly, setup or use.

As this model aircraft is a sophisticated hobby product, it must be flown with safety and common sense in mind, failure in doing so may result in injury or property damage. This product is not intended for use by children without direct adult supervision.

Safety precautions and warnings

As the user, you are solely responsible for the safe operation and maintenance of this product. Follow the directions and warnings listed in this manual, as well as that of supporting equipment (chargers, batteries etc.) and always use common sense.

This is not a toy. Not for children under 14 years of age.

- Always operate your model in an open area away from buildings, cars, traffic or people. Never operate near people-especially children who can wander unpredictably. Never operate in populated areas for any reason, where injury or damage can occur.
- Always keep a safe distance in all directions around your model to avoid collisions or injury. This model is controlled by a radio signal subject to interference from many sources outside your control. Interference can cause momentary loss of control.
- Never catch the aircraft while it is in flight, the structure of the fuselage was not designed and protected for this purpose. Never operate your model in bad weather, including in excessively windy or precipitating conditions.
- Never operate your model with low transmitter batteries.
- Keep your throttle quadrant in its lowest position prior and after every flight. Use the throttle cut function if able. Always use fully charged batteries and move batteries before disassembly.
- Avoid water exposure to all equipment not specifically designed and protected for this purpose.
- Avoid cleaning this product with chemicals.
- Never lick or place any part of your model in your mouth as it could cause serious injury or even death.
- Keep all chemicals, small parts and anything electrical out of the reach of children.

Introduction

The Husky is a PA-18 inspired, high-winged light utility aircraft which made its first flight in 1986.

Arrows hobby has recreated this backcountry workhorse- from rivet lines and body panels to the predictable STOL flight characteristics- without overlooking any detail when creating the 1800mm Husky.

Packed full of attractive features, the Arrows 1800mm Husky is prebuilt with a rugged CNC landing gear, oversized balloon tires and functional flaps for true STOL backcountry operations. A 3541 750KV motor paired with a 45A ESC gives the aircraft near vertical performance, while the screw-together assembly means the Husky is ready for flight in no time.

Perfect for beginners and experts alike, the Husky is the ultimate Bush plane every pilot needs!

Features

- Power system: 3541-750Kv motor, 45A ESC, 17g servos x6.
- Excellent STOL and slow speed performance, allowing takeoffs within 3m.
- CNC landing gear absorb hard landings.
- Ultra durable oversized tires.
- Scale navigation and landing lights.
- Oversized battery compartment.

Table of contents

| | |
|---|----|
| Introduction ----- | 3 |
| Specifications ----- | 3 |
| Kit contents ----- | 3 |
| Model Assembly ----- | 4 |
| Battery installation ----- | 7 |
| Receiver diagram ----- | 7 |
| Preflight check ----- | 7 |
| Clevis installation ----- | 8 |
| Control horn and servo arm settings ----- | 9 |
| Centre of gravity (CG) ----- | 9 |
| Before flying the model ----- | 9 |
| Flight tips ----- | 10 |
| Troubleshooting ----- | 11 |
| Spare parts list ----- | 11 |

Specifications

| | |
|---------------------|------------------------|
| Wingspan | 1800mm |
| Lenght | 1200mm |
| Flying weight | 2100g |
| Motor size | 3541-KV750 |
| Wing load | 50g/dm ² |
| Wing area | 47.7dm ² |
| Propeller size | - |
| ESC | 45A |
| Servo | 17g (6pcs) |
| Recommended battery | 14.8V 2200-2600mAh 35C |

Kit contents

Before assembly, please inspect the contents of the kit. The photo below details the contents of the kit with labels. If any parts are missing or defective, please identify the name or part number (refer to the spare parts list near the end of the manual) then contact your local shop.

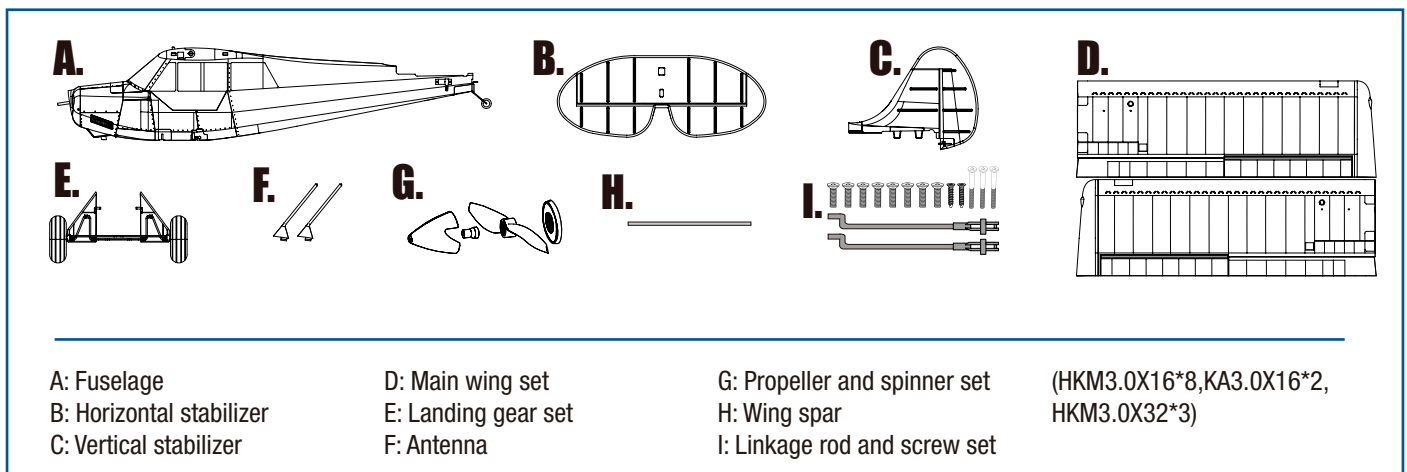

MODEL ASSEMBLY

Landing gear installation

1. With the fuselage inverted, slide the landing gear into the fuselage slots as shown.

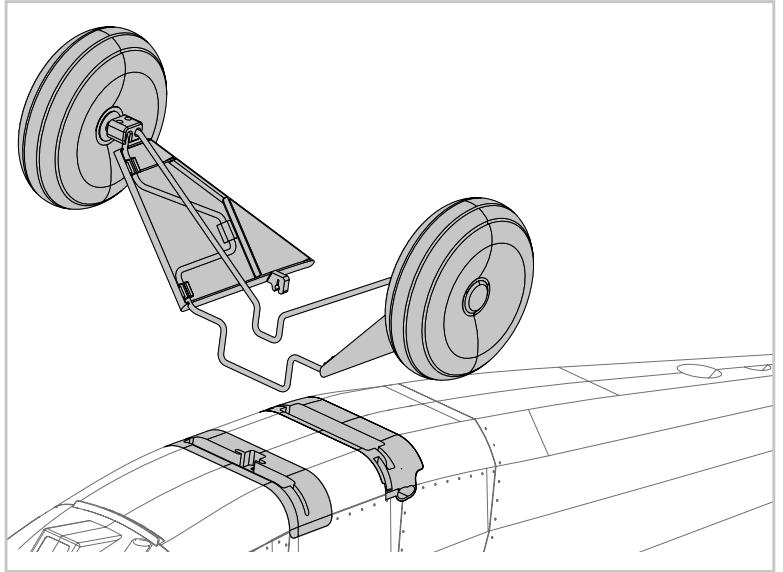

2. Slide the landing gear retainers into the fuselage slots and secure the assembly using the included screws.

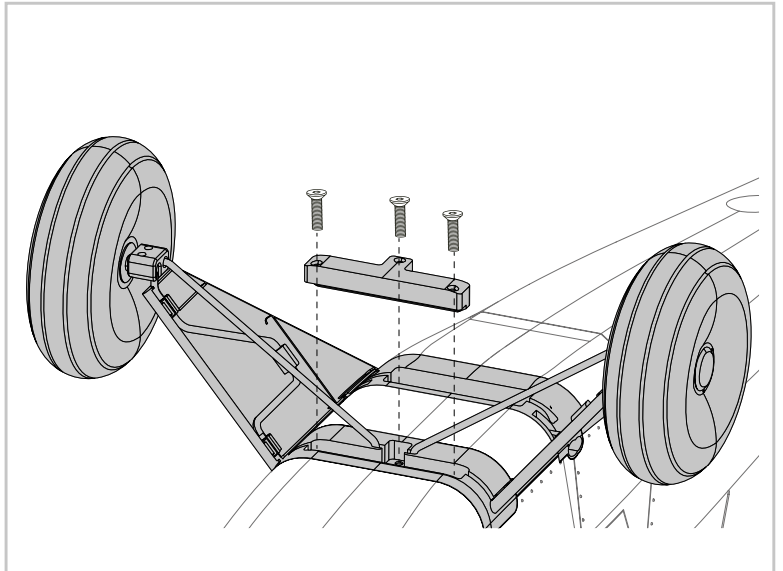

Wing installation

1. Slide the wing spar into the fuselage pass through.

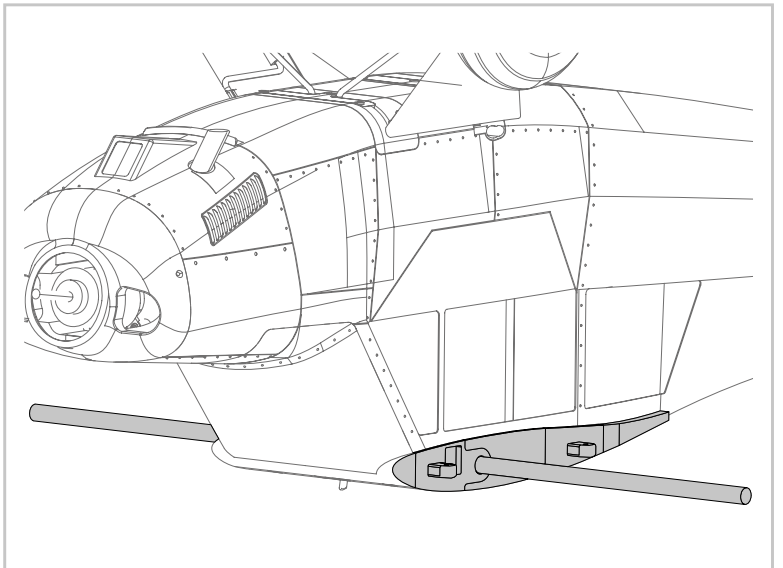

MODEL ASSEMBLY

2. Attach the wing struts to the wing as shown.

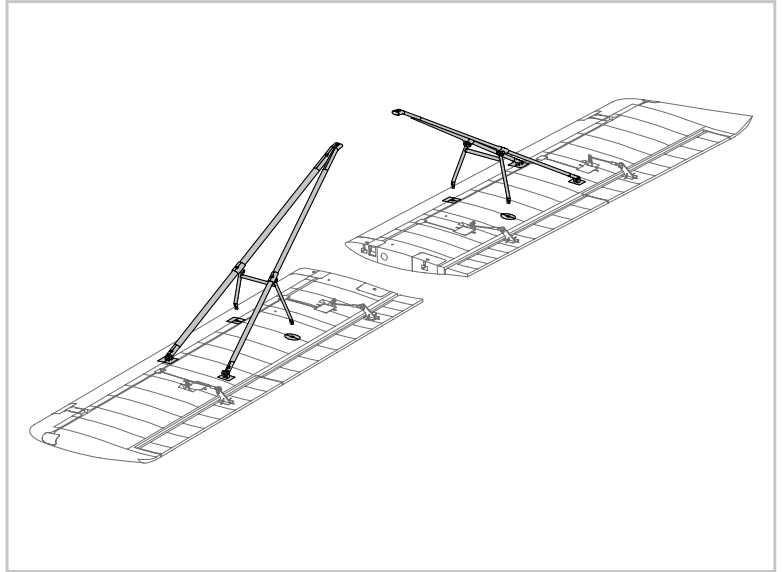

3. With the fuselage inverted, connect the aileron servo wire then secure the wing and wing struts using the included screws.

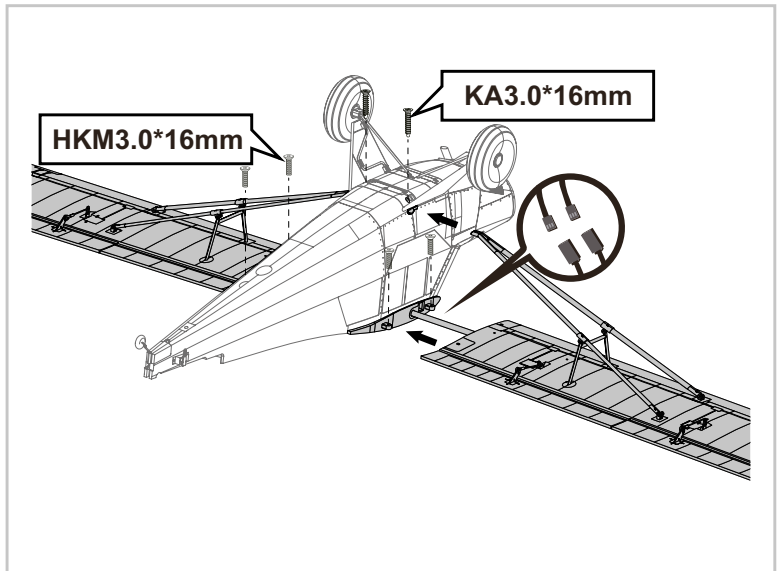

Horizontal and vertical stabilizer installation

1. Place the horizontal stabilizer onto the fuselage cutout.

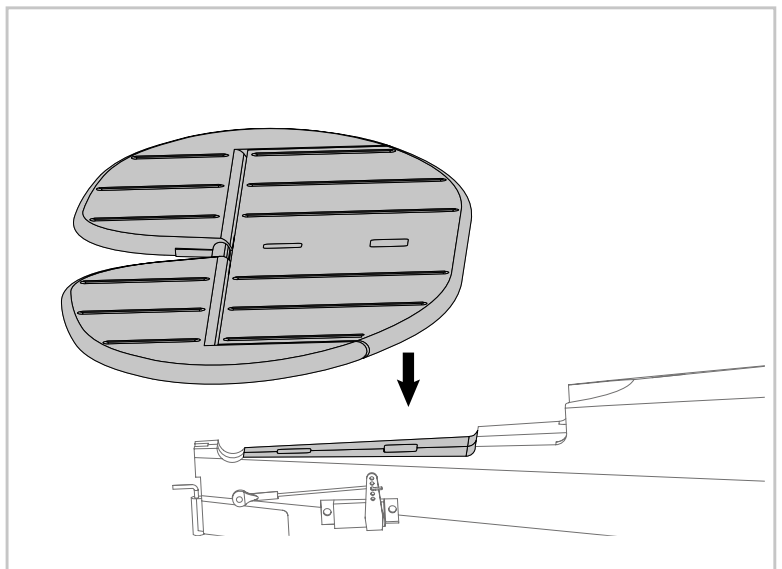

MODEL ASSEMBLY

2. Place the vertical stabilizer onto the horizontal stabilizer. Secure using the included screw.

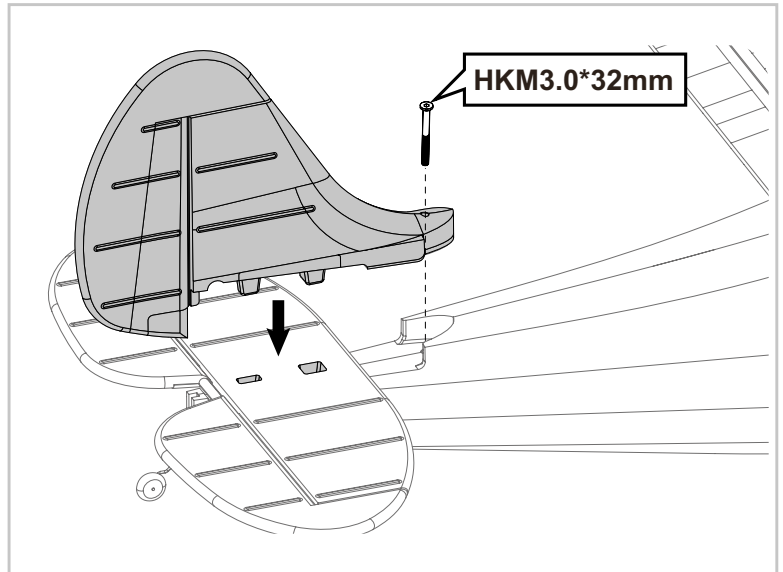

3. Attach both tailfins to the fuselage using the included screws.

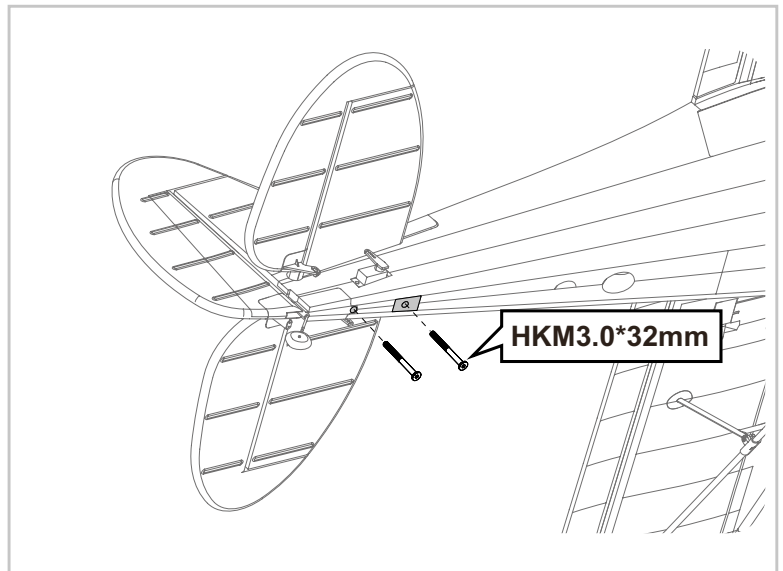

Pushrod installation

1. With the servo and elevator centered, connect the servo to the control surface using a pushrod.

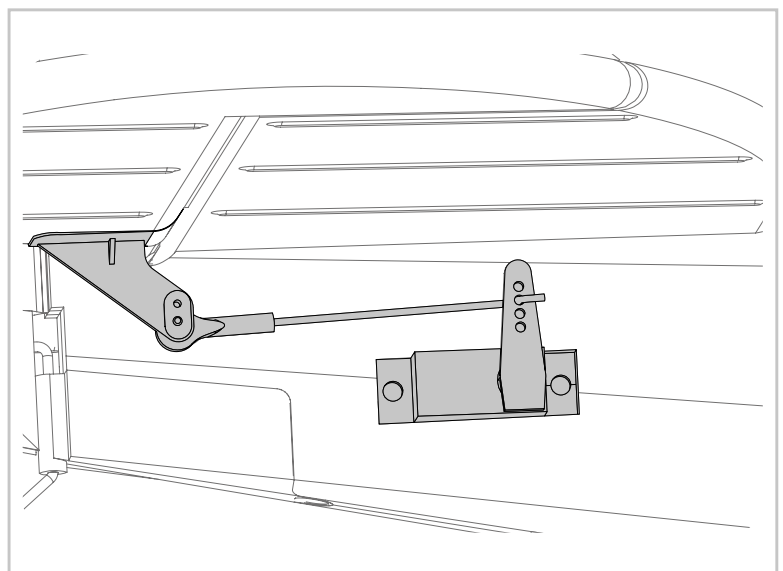

MODEL ASSEMBLY

2. With the servo and rudder centered, connect the servo to the control surface using a pushrod.

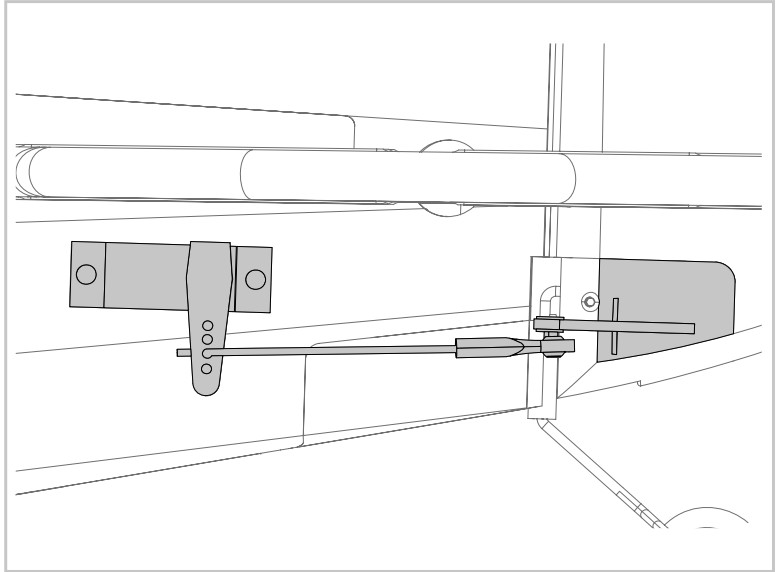

Antenna installation

Place the antennae into their positions on top of the wings as shown, then push them aft to secure.

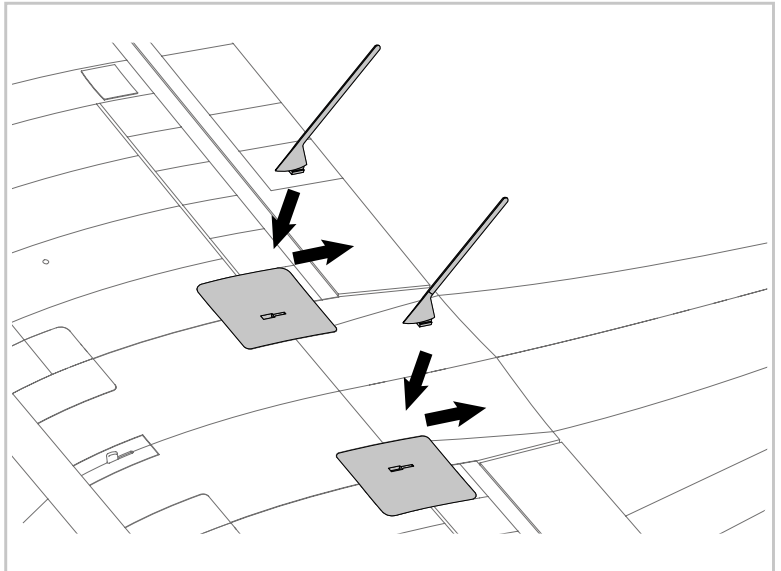

Propeller installation

1. Assemble the spinner and propeller as shown.

Note: the motor should rotate clockwise when viewing the plane from the rear.

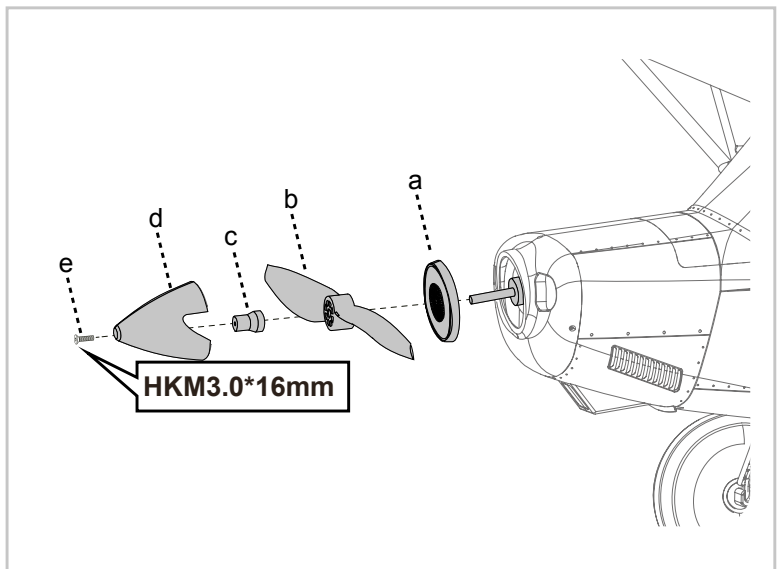

BATTERY INSTALLATION

1. Remove the battery cover.
2. Remove the hook and loop tape from the fuselage. Apply the looped surface to the battery.
3. Install the battery into the fuselage- securing it with the preinstalled battery straps.

Note: The weight of each battery may vary due to different manufacturing techniques. Move the battery fore or aft to achieve the optimal center of gravity.

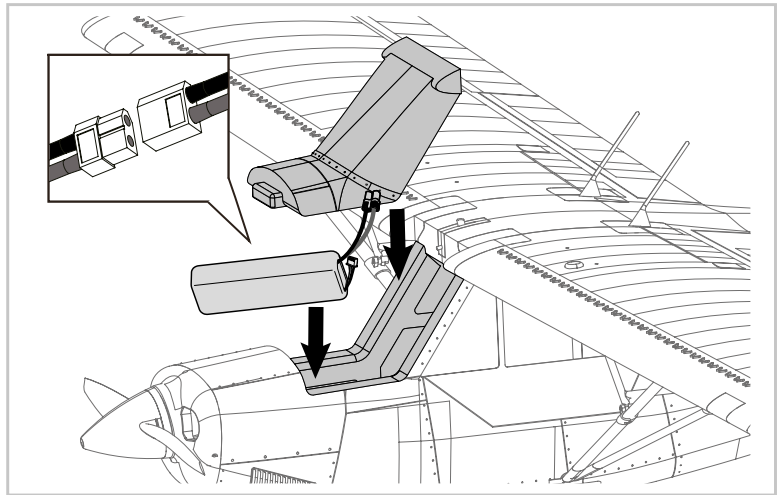

Receiver diagram

The cables from the servo connector board should be connected to your receiver in the order shown. Note that the LEDs can be powered by any spare channel on the receiver. Tuck the wire leads into the recessed cavity towards the rear of the battery hatch.

| RECEIVER | | |
|----------|---|-------------------|
| Ailero | 1 | Channel-1 (Aile.) |
| Elevator | 2 | Channel-2 (Elev.) |
| Throttle | 3 | Channel-3 (Thro.) |
| Rudder | 4 | Channel-4 (Rudd) |
| Spare | 5 | Channel-5 (Spare) |
| Flap | 6 | Channel-6 (Flap) |

PREFLIGHT CHECK

Important ESC and model information

1. The ESC included with the model has a safe start. If the motor battery is connected to the ESC and the throttle stick is not in the low throttle or off position, the motor will not start until the throttle stick is moved to the low throttle or off position. Once the throttle stick is moved to the low throttle or off position, the motor will emit a series of beeps. Several beeps with the same tune means the ESC has detected the cells of the battery. The count of the beeps equals the cells of the battery. The motor is now armed and will start when the throttle is moved.
2. The motor and ESC come pre-connected and the motor rotation should be correct. If for any reason the motor is rotating in the wrong direction, simply reverse two of the three motor wires to change the direction of rotation.
3. The motor has an optional brake setting. The ESC comes with brake switched off and we recommend that the model be flown with the brake off. However, the brake could be accidentally switched on if the motor battery is connected to the ESC while the throttle stick is set at full throttle. To switch the brake off, move the throttle stick to full throttle and plug in the motor battery. The motor will beep one time. Move the throttle stick to low throttle or the off position. The motor is ready to run and the brake will be switched off.
4. Battery Selection and Installation. We recommend the 14.8V 2200-2600mAh 35C Li-Po battery. If using another battery, the battery must be at least a 14.8V 2200-2600mAh 35C battery. Your battery should be approximately the same capacity, dimension and weight as the 14.8V 2200-2600mAh 35C Li-Po battery to fit the fuselage without changing the center of gravity significantly.

PREFLIGHT CHECK

Transmitter and Model setup

After assembly and prior to your first flight, make sure all control surfaces respond correctly to your transmitter by referring to the diagram below.

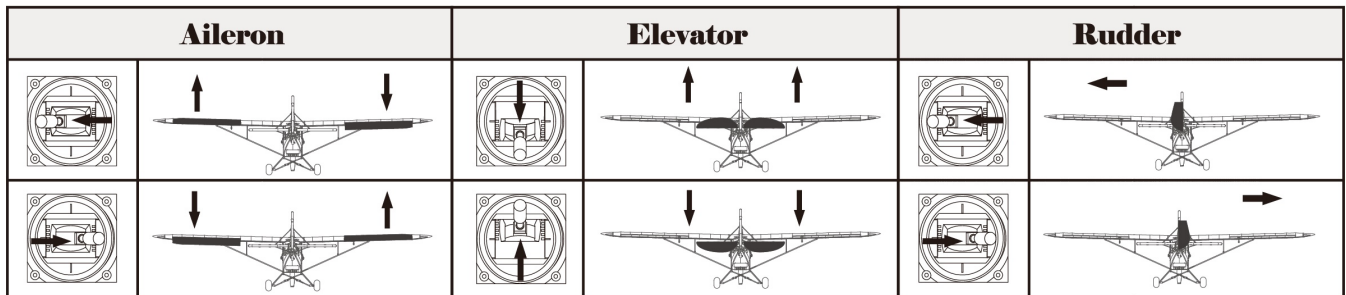

Control setup

The suggested control throw setting for the model are as follows (dual rate setting):

Tip: The maiden flight should always be flown using low rates, fly the aircraft until you are familiar with its characteristics prior to trying high rates. Make sure the aircraft is flying at altitude and adequate velocity prior to using high rates, as the aircraft will be sensitive to control inputs with the larger control surface movements.

| | High rate | Low Rate |
|-----------------|-----------------|-----------------|
| Elevator | 18mm Up/Down | 14mm Up/Down |
| Aileron | 16mm Up/Down | 12mm Up/Down |
| Rudder | 28mm Left/Right | 20mm Left/Right |

Clevis installation

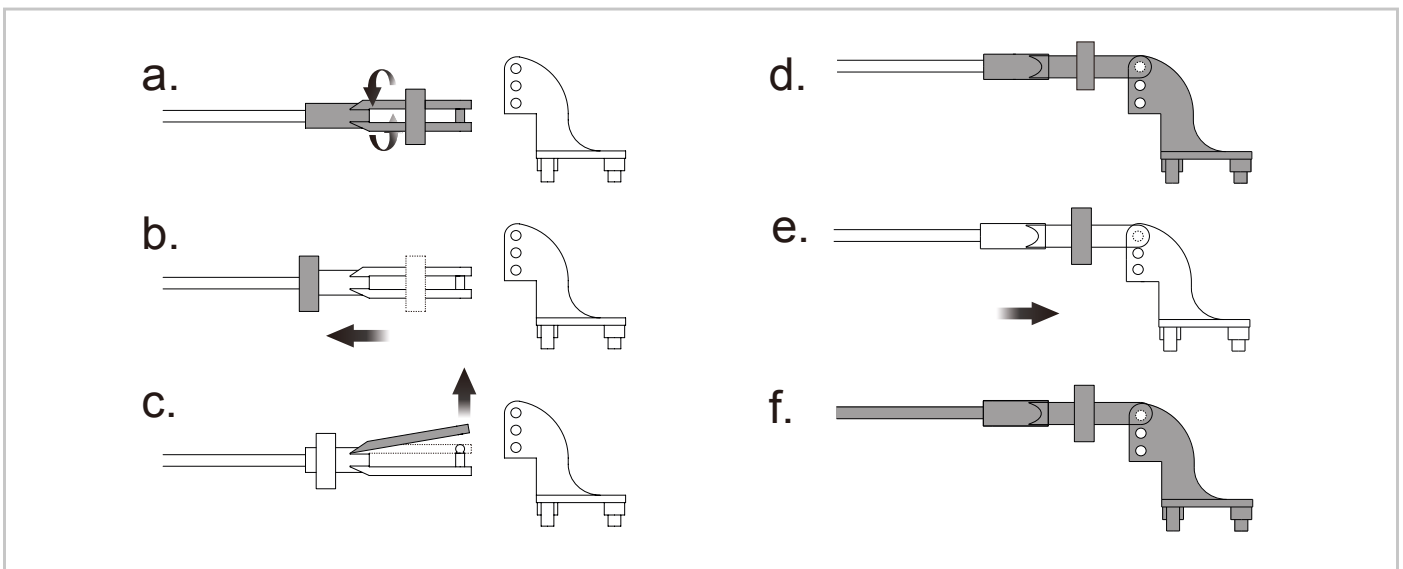

1. Pull the tube from the clevis to the linkage.
2. Carefully spread the clevis, then insert the clevis pin into the desired hole in the control horn.
3. Move the tube to hold the clevis on the control horn.

CONTROL HORN AND SERVO ARM SETTINGS

1. The table shows the factory settings for the control horns and servo arms. Fly the aircraft at the factory settings before making changes.
2. After flying, you may choose to adjust the linkage positions for the desired control response.

| | Horns | Arms | |
|----------|-------|------|--|
| Elevator | | | =More control =Less control |
| Rudder | | | |
| Ailerons | | | |

CENTRE OF GRAVITY

Finding the correct center of gravity is critical in ensuring that the aircraft performs in a stable and responsive manner. Please adjust the weight distribution so the aircraft balances in the range stated on the diagram.

- Depending on the capacity and weight of your chosen flight batteries, move the battery forward or backward to adjust the center of gravity.
- If you cannot obtain the recommended CG by moving the battery to a suitable location, you can also install a counterweight to achieve correct CG. However, with the recommended battery size, a counterweight is not required. We recommend flying without unnecessary counterweight.

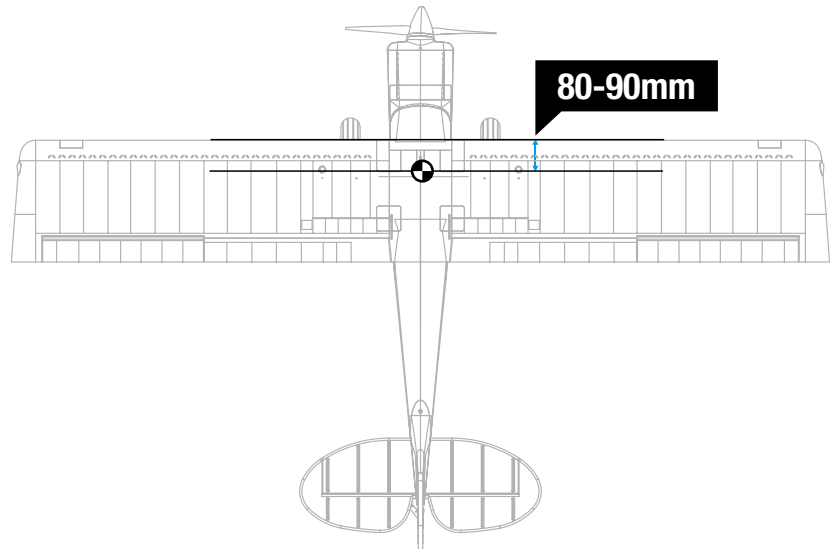

BEFORE FLYING THE MODEL

Find a suitable flying site

Find a flying site clear of buildings, trees, power lines and other obstructions. Until you know how much area will be required and have mastered flying your plane in confined spaces, choose a site which is at least the size of two to three football fields - a flying field specifically for R/C planes is best. Never fly near people - especially children, who can wander unpredictably.

Performing a range check

A radio range check should be performed prior to the first flight of the day. This test may assist you in detecting electronic problems that may lead to a loss of control- problems such as low transmitter batteries, defective or damaged radio components or radio interference. This usually requires an assistant and should be done at the flying site.

BEFORE FLYING THE MODEL

Always turn your transmitter on first. Install a fully charged battery in the battery bay, then connect it to the ESC. In this process, make sure that the throttle cut functionality is on, and that the throttle stick is secured in its lowest position- other-wise, the propeller/fan will engage and possibly cause bodily harm.

Note: Please refer to your transmitter manual that came with your radio control system to perform a ground range check. If the controls are not working correctly or if anything seems wrong, do not fly the model until you correct the problem. Make certain all the servo wires are securely connected to the receiver and the transmitter batteries have a good connection.

Monitor your flight time

Monitor and limit your flight time using a timer (such as a stopwatch or on the transmitter, if available). As modern Lithium Polymer batteries are not designed to discharge completely, when the battery runs low, the ESC will lower then completely cut the power to the motors to protect the battery. Often (but not always) power can be briefly restored after the motor cuts off by holding the throttle stick all the way down for a few seconds. To avoid an unexpected dead-stick landing on your first flight, set your timer to a conservative 4 minutes. When your alarm sounds you should land right away.

FLIGHT TIPS

Take off

Point the aircraft into the wind while slowly applying power until the aircraft starts to track straight, use the rudder when necessary. When the aircraft reaches takeoff speed, ease back on the elevator stick until the aircraft is climbing at a constant rate without decelerating. Climbing at too steep of an angle at the relatively low speeds of a takeoff-climb may result in an aerodynamic stall.

Flying

Always choose a wide-open space for flying your plane. It is ideal for you to fly at a sanctioned flying field. If you are not flying at an approved site always avoid flying near houses, trees, wires and buildings. You should also be careful to avoid flying in areas where there are many people, such as busy parks, schoolyards, or soccer fields. Consult laws and ordinances before choosing a location to fly your aircraft. After takeoff, gain some altitude. Climb to a safe height before trying technical manoeuvres.

Landing

Land the aircraft when you start to feel sluggish motor response. If using a transmitter with a timer, set the timer so you have enough flight time to make several landing approaches. The model's three point landing gear allows the model to land on hard surfaces. Align model directly into the wind and fly down to the ground. Fly the airplane down to the ground using 1/4-1/3 throttle to keep enough energy for proper flare. Before the model touches down, always fully decrease the throttle to avoid damaging the propeller or other components. The key to a great landing is to manage the power and elevator all the way to the ground and set down lightly on the main landing gear. With some practice, you will be able to set the aircraft gently on its main gear and hold it that way until the speed reduces enough where the nose wheel (tricycle landing gear aircraft) or tail wheel (tail draggers) settles onto the ground.

Maintenance

Repairs to the foam should be made with foam safe adhesives such as hot glue, foam safe CA, and 5min epoxy. When parts are not repairable, see the spare parts list for ordering by item number.

Always check to make sure all screws on the aircraft are tightened. Pay special attention to make sure the spinner is firmly in place before every flight.

TROUBLESHOOTING

| PROBLEM | POSSIBLE CAUSE | SOLUTION |
|---|--|--|
| Aircraft will not respond to the throttle but responds to other controls. | <ul style="list-style-type: none"> • ESC is not armed. • Throttle channel is reversed. | <ul style="list-style-type: none"> • Lower throttle stick and throttle trim to lowest settings. • Reverse throttle channel on transmitter. |
| Excessive vibration or propeller noise. | <ul style="list-style-type: none"> • Damaged spinner, propeller, motor or motor mount. • Loose propeller and spinner parts. Propeller installed backwards. | <ul style="list-style-type: none"> • Replace damaged parts. • Tighten parts for propeller adapter, propeller and spinner. • Remove and install propeller correctly. |
| Reduced flight time or aircraft underpowered. | <ul style="list-style-type: none"> • Flight battery charge is low. Propeller installed backward. Flight battery damaged. | <ul style="list-style-type: none"> • Completely recharge flight battery. • Replace flight battery and follow flight battery instructions. |
| Control surfaces unresponsive or sluggish. | <ul style="list-style-type: none"> • Control surface, control horn, linkage or servo damage. • Wire damaged or connections loose. | <ul style="list-style-type: none"> • Replace or repair damaged parts and adjust controls. • Do a check of connections for loose wiring. |
| Controls reversed. | <ul style="list-style-type: none"> • Channels are reversed in the transmitter. | <ul style="list-style-type: none"> • Do the control direction test and adjust controls for aircraft and transmitter. |
| Motor loses power Motor power pulses then motor loses power. | <ul style="list-style-type: none"> • Damage to motor, or battery. • Loss of power to aircraft. • ESC uses default soft Low Voltage Cutoff(LVC). | <ul style="list-style-type: none"> • Do a check of batteries, transmitter, receiver, ESC, motor and wiring for damage(replace as needed). • Land aircraft immediately and recharge flight battery. |
| LED on receiver flashes slowly. | <ul style="list-style-type: none"> • Power loss to receiver. | <ul style="list-style-type: none"> • Check connection from ESC to receiver. • Check servos for damage. • Check linkages for binding. |

SPARE PARTS LIST

| | | | |
|---------|------------------------|------------|---------------------------------|
| AHAJ101 | Fuselage | AHAJ113 | LED |
| AHAJ102 | Main wing set | AHAJ114 | Lamp Cover |
| AHAJ103 | Horizontal stabilizer | AHAJ115 | Sticker |
| AHAJ104 | Vertical stabilizer | AHAJ116 | Linkage rod |
| AHAJ105 | Battery Hatch | AHAJ117 | Screw set |
| AHAJ106 | Wheel set | AHPROP009 | Propeller |
| AHAJ107 | Front landing gear set | AHShaft003 | Motor shaft |
| AHAJ108 | Supporting bar set | AHMount003 | Motor Mount |
| AHAJ109 | Cowl | AHBoard008 | Motor Board |
| AHAJ110 | Propeller plate | AHKV750 | Brushless motor |
| AHAJ111 | Wing Pipe | AHESC45A | 45A ESC |
| AHAJ112 | Antenna | AH17DGP | 17g digital gear servo positive |



Arrows RC is distributed by Pro Models

Geelseweg 80 • 2250 Olen • Belgium • info@promodels.be