



The GREEN HORNET™

The Black Beauty

WITH GREEN HORNET & KATO FIGURES

1/25 SCALE PLASTIC MODEL KIT

READ THIS BEFORE YOU BEGIN

Cement all parts unless otherwise indicated. Look over this instruction sheet carefully before you begin building. Follow the assembly instructions and "test-fit" the parts without cementing. This will familiarize you with the location of the parts.

For the best results, the various sub-assemblies and components should be painted before any "chrome" parts are attached. For example: When attaching "non-chrome" body accessories, it is best to cement them in place and paint the body as a unit.

AMT® kits are molded from the finest High-Impact Styrene plastic. Use only paint and cement made for Styrene. Trim excess plastic from parts before joining. When attaching "chrome" parts, scrape plating away where parts are to be joined. Use just enough cement to join parts, and be careful not to smear cement on exposed surfaces.

Built according to the instructions on this sheet, you should have no trouble assembling your kit. Just FOLLOW THE NUMBERS, as parts are numbered in order of assembly. (C) INDICATES "CHROME" PARTS

BUILDING TIPS FOR THE ADVANCED MODELER

For the best possible finish, your kit should be painted, even if molded in color. Paint should be applied evenly, in several thin coats rather than one heavy coat. The first coat should not completely cover the surface. Each layer should be allowed to thoroughly dry before the next is applied. Also, each coat should be "wet sanded", except for the final coat, using No.1200 wet or dry sandpaper which is slightly damp. Be careful not to remove any detail while sanding.

It is important to keep your hands clean when working with your model. Wash parts thoroughly before painting to remove any mold release agent that may have been used during manufacture, body oil from your hands, sanding residue, and dust, which is naturally attracted to plastic by static electricity. Use a mild solution of dishwashing detergent and water. A tack rag should be used to dry the parts, DO NOT use paper towels or tissues, since they will leave lint on the part.

Parting lines and glue joints should be sanded or filed prior to painting and cementing. Because paint has a tendency to draw away from sharp edges, they should be lightly filed. Use filler putty designed for plastic to fill small gaps that may occur between parts and to blend contours. This should be done only after the first, or "primer," coat of paint is applied.

When painting a two-tone body, the lightest color should be painted first. Use frosted, or "magic," tape to mask off the area you do not want painted. After the second color is dry to the touch, the tape can be removed. Use a very fine brush to touch up edges if necessary. If decals are to be added, do so before adding any gloss coat. A gloss coat will help even out the edges between the two colors as well as set the decals.

NOTE: When planning on filling seams and painting the body, parts 19, 3, and 23 should be located to body before doing so. Otherwise continue with assembly as shown.

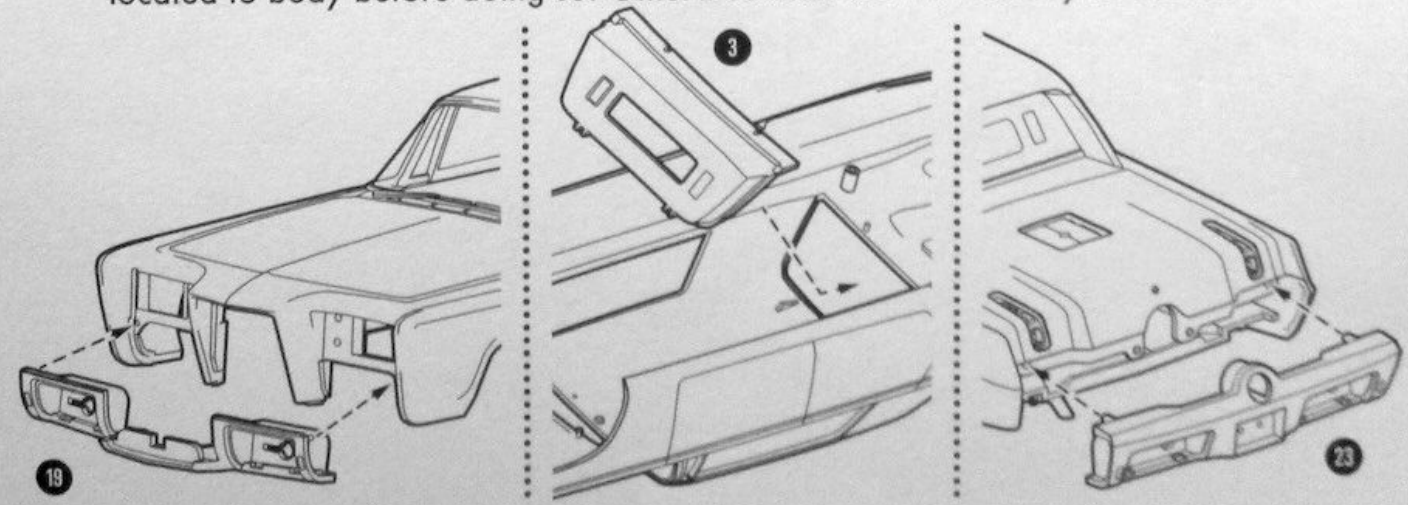

1. DASHBOARD

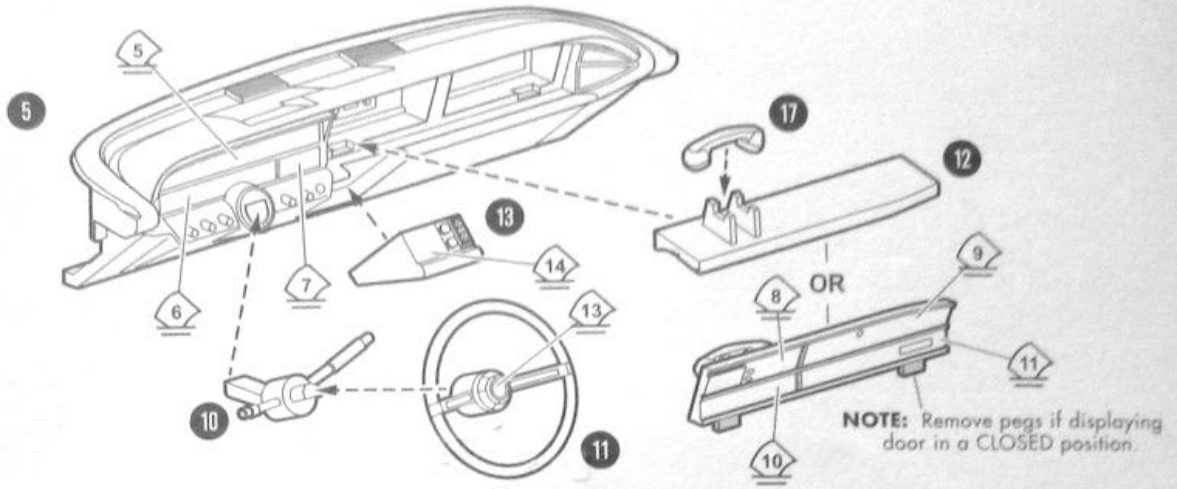

2. FIGURES

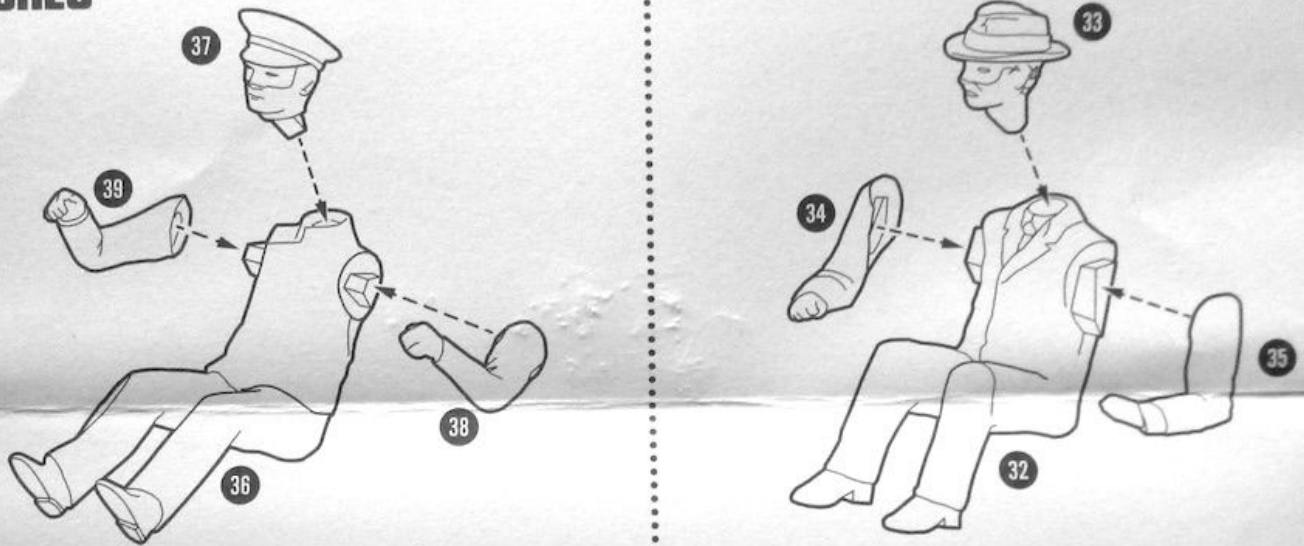

3. FRONT SEAT/PARTITION

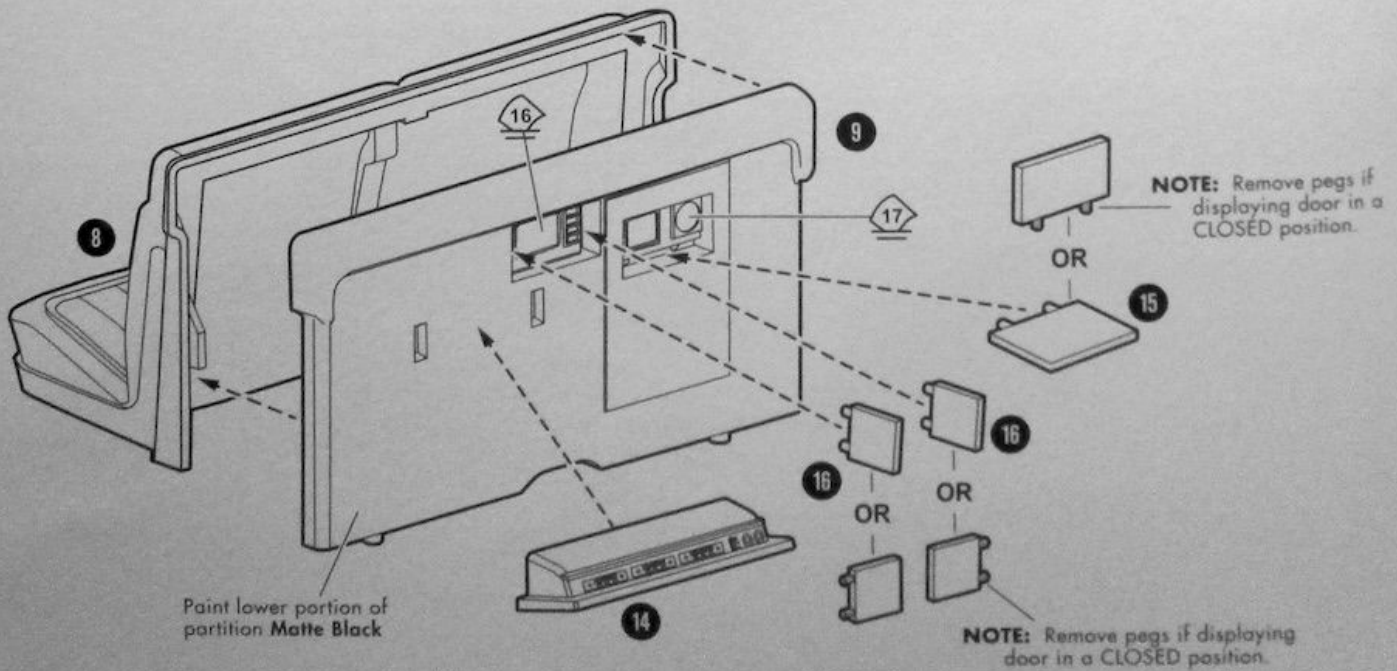

4. INTERIOR

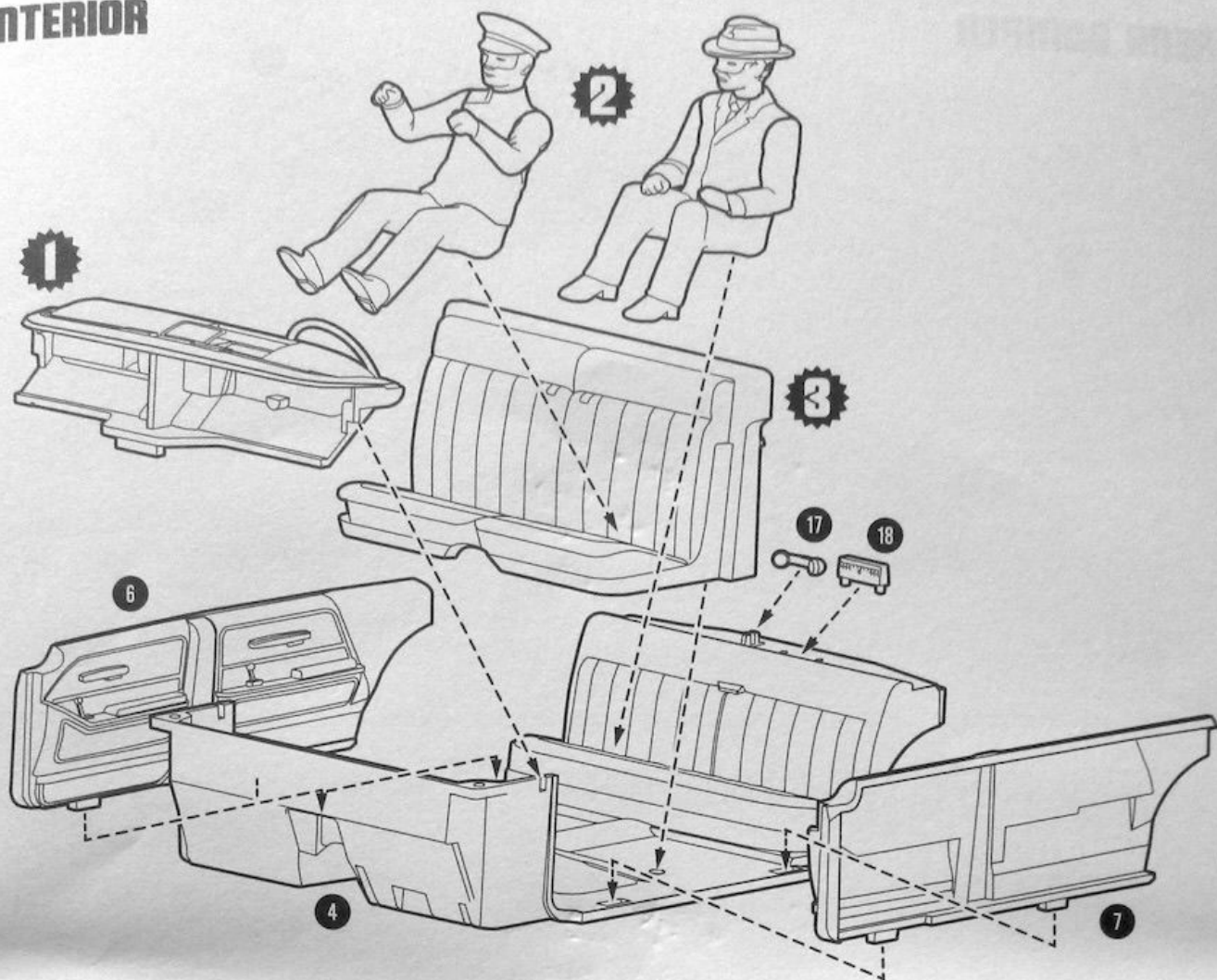

5. WINDOWS

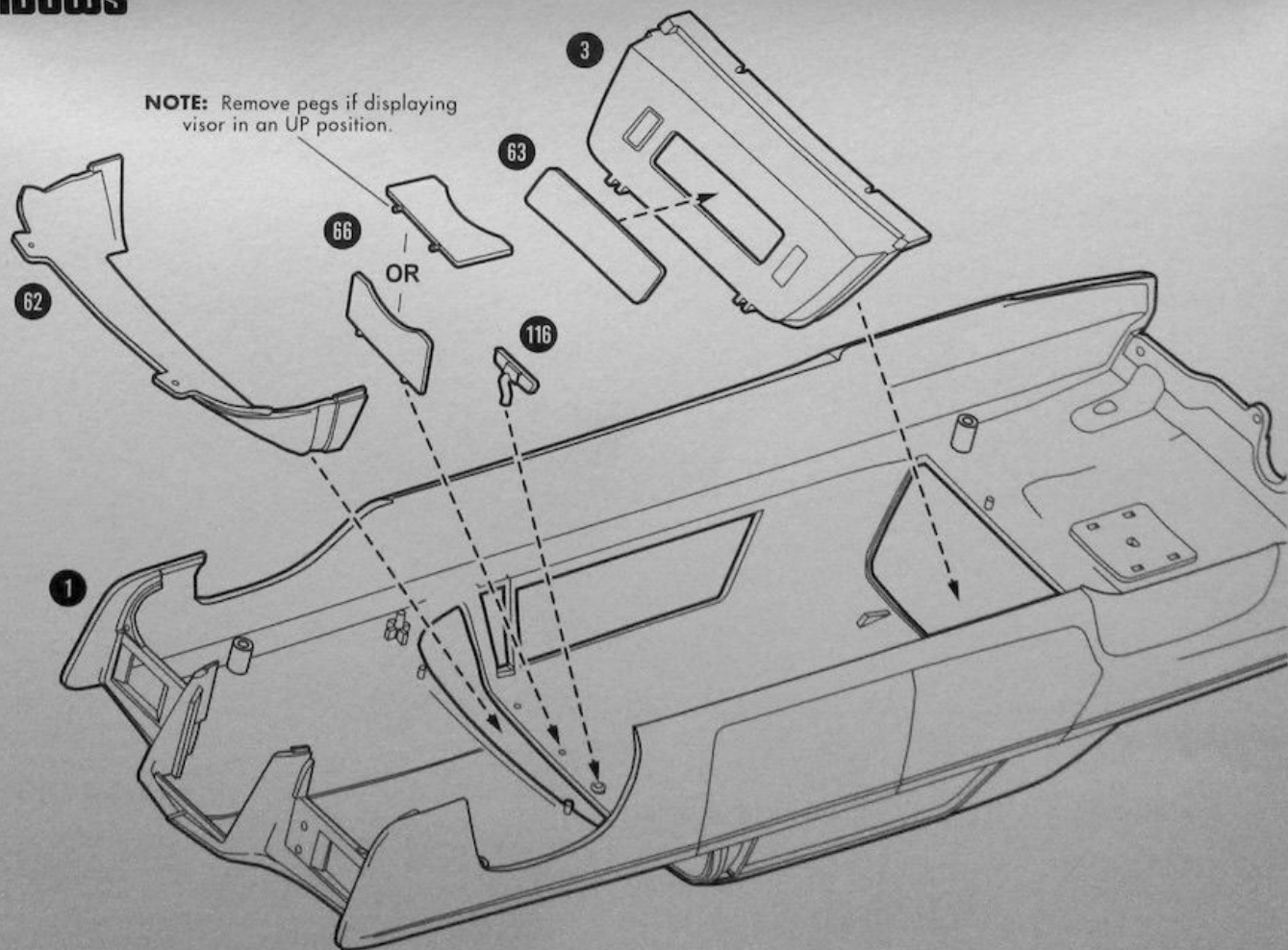

6. WHEELS x4

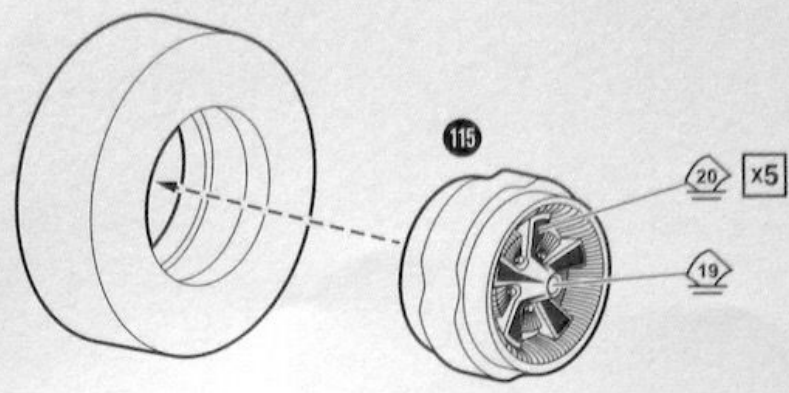

7. BODY TO CHASSIS

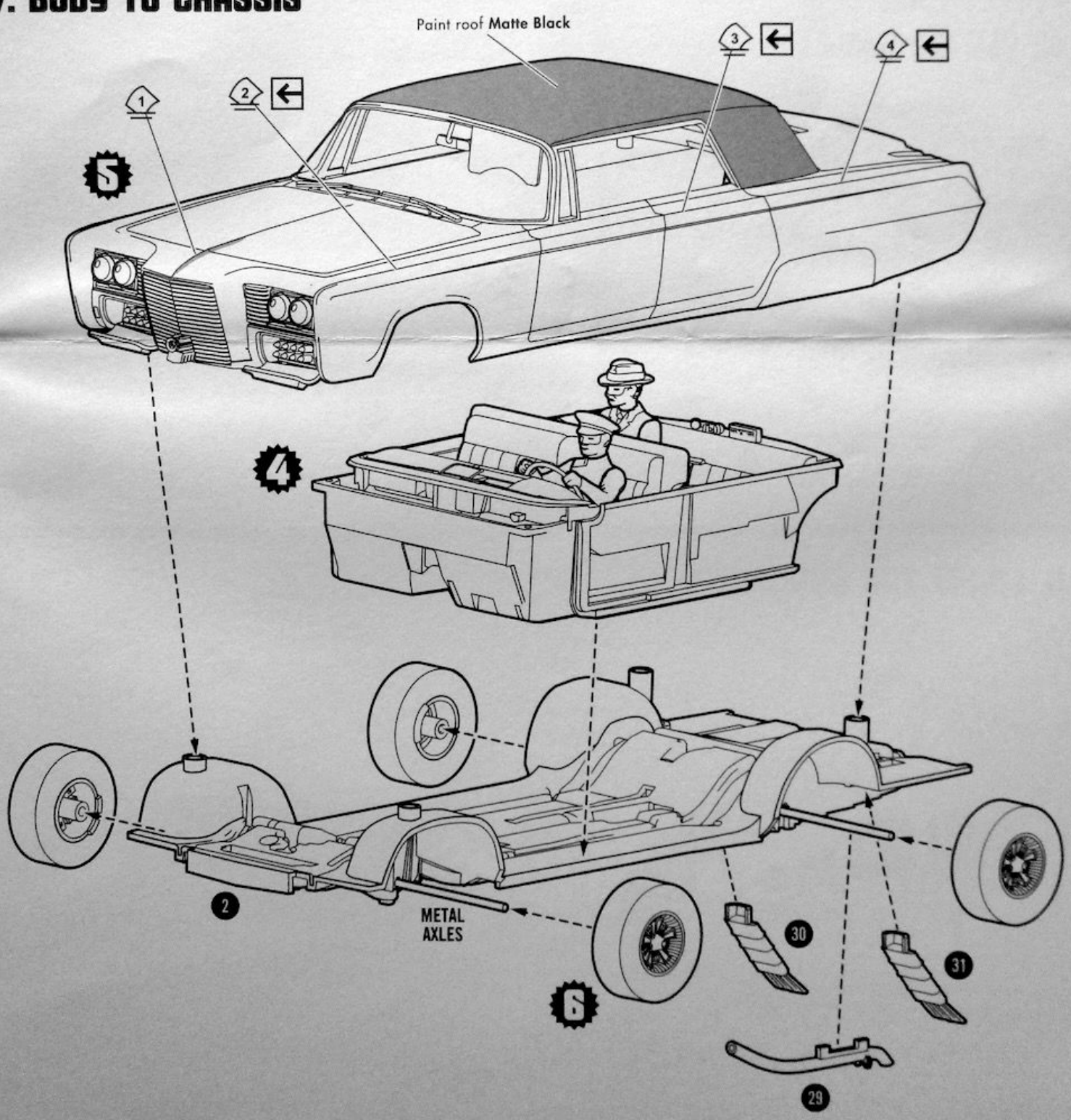

8. FRONT BUMPER

NOTE: Remove pegs if displaying door in a CLOSED position.

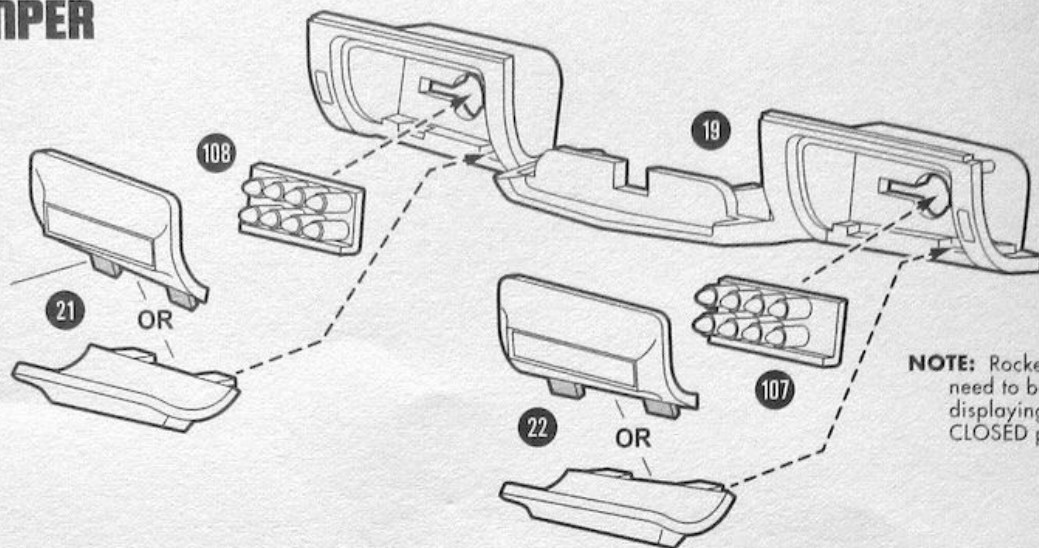

NOTE: Rockets may need to be left off, if displaying door in a CLOSED position.

9. CENTER GRILLE

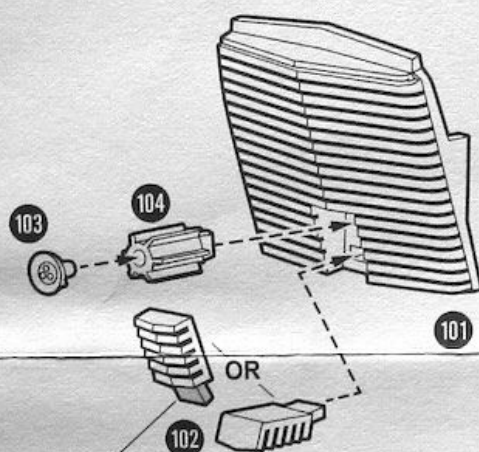

NOTE: Remove peg if displaying door in a CLOSED position.

10. HEADLIGHTS

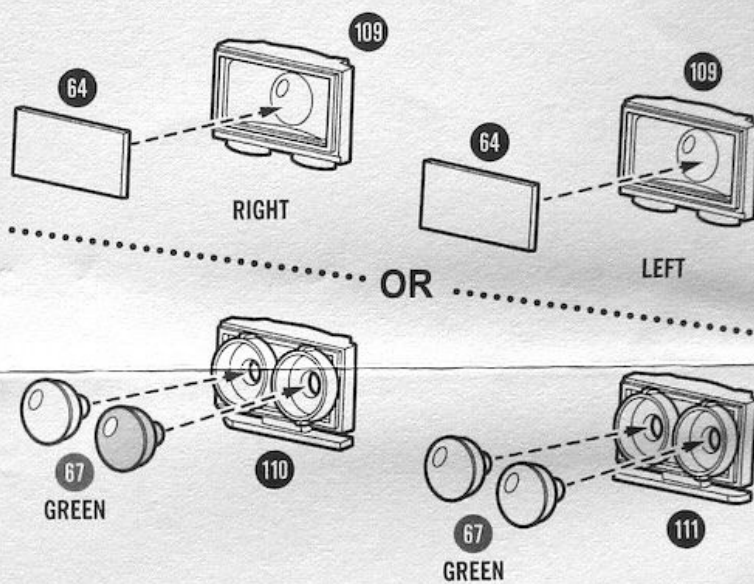

11. FRONT END ASSEMBLY

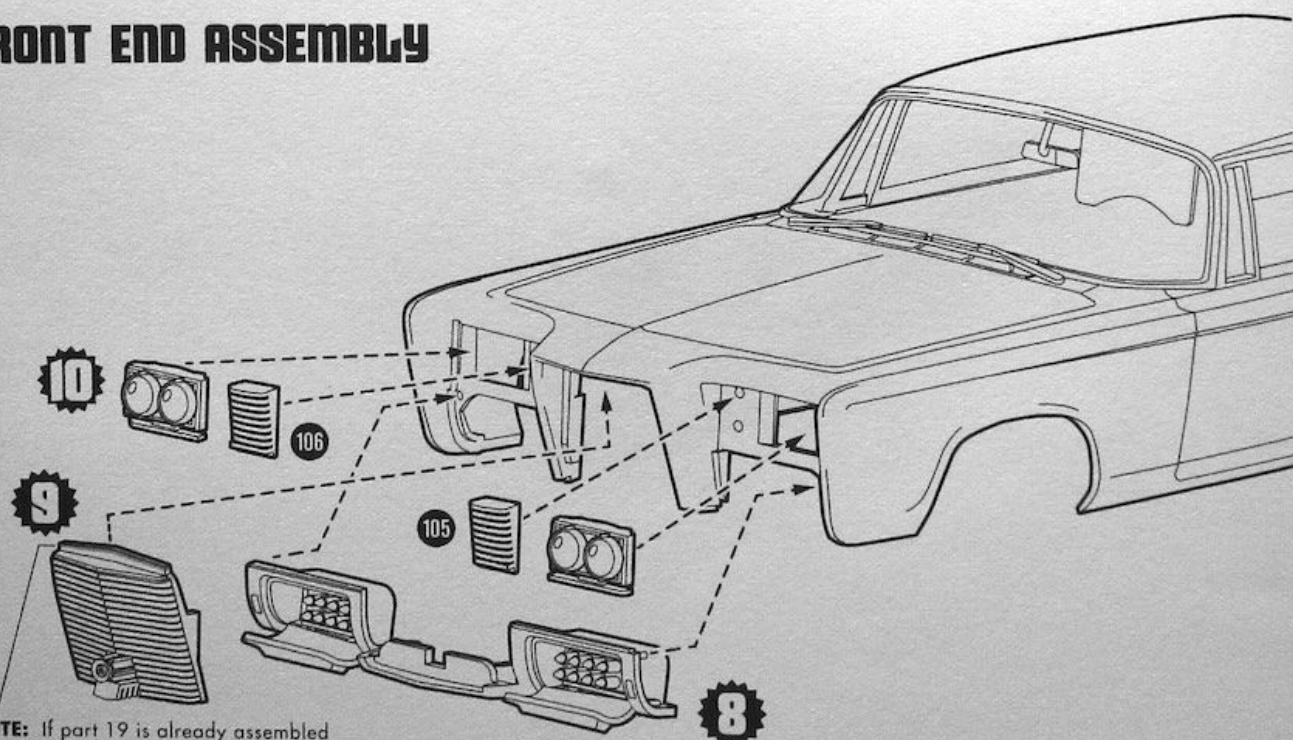

NOTE: If part 19 is already assembled to Body, Center Grille (part 101) may need to be trimmed to fit opening.

12. REAR BUMPER

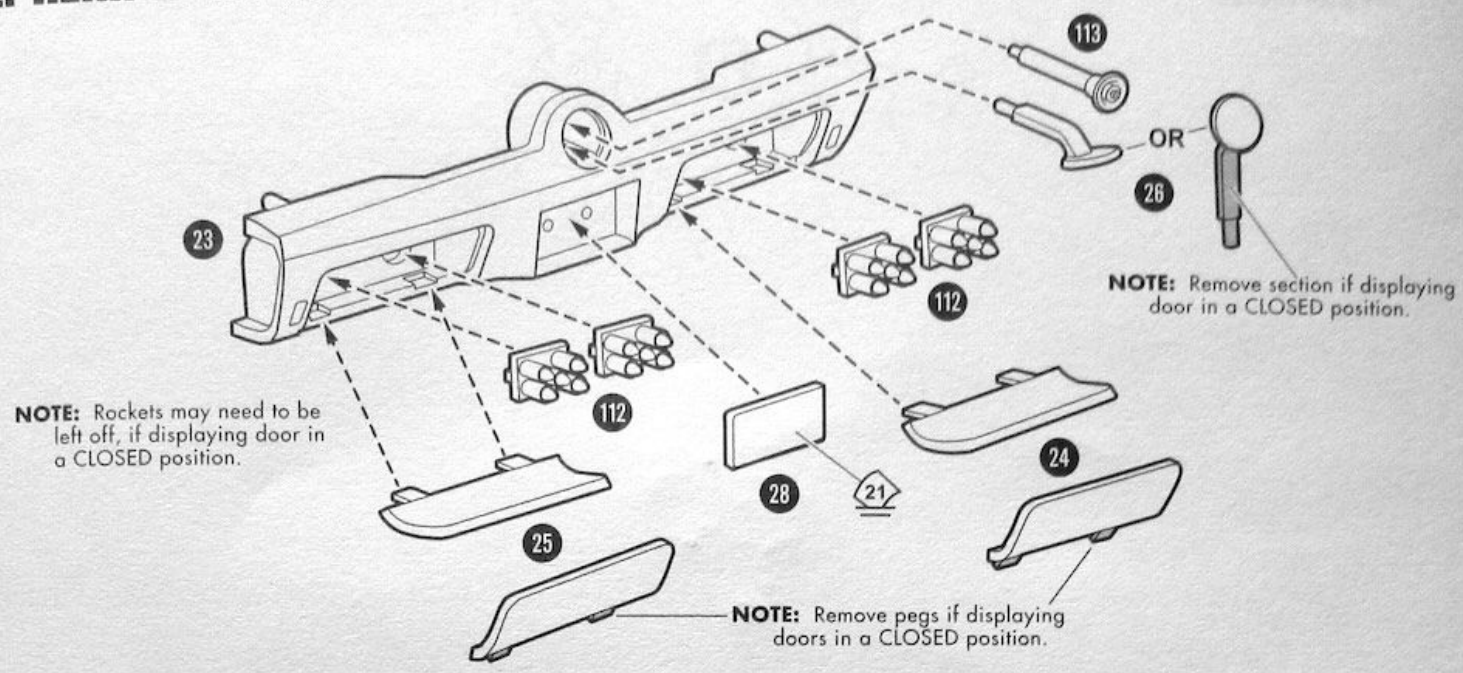

13. SCANNER SATELLITE / TAILLIGHTS

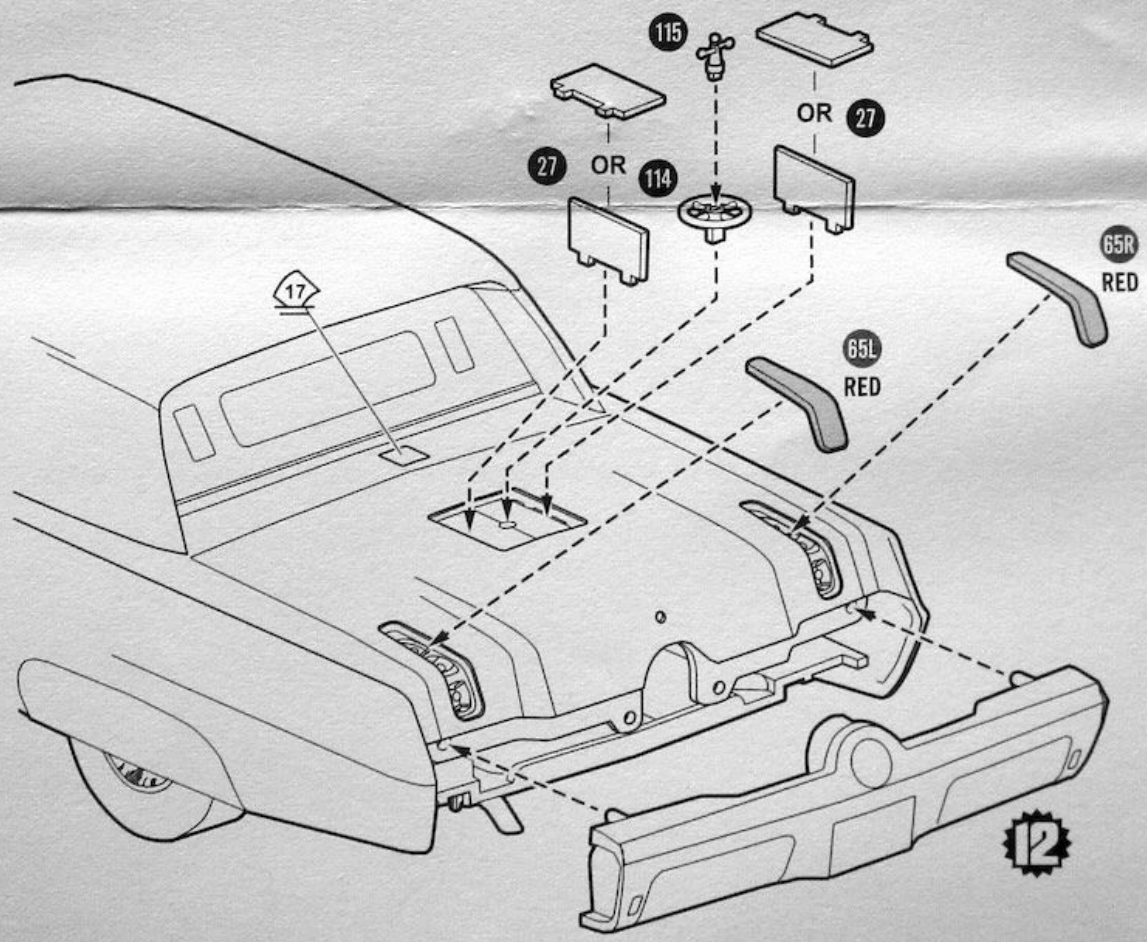

SYMBOLS

00	Part Number		Decal
	Clear Part		Repeat Several Times
	Chrome Part		Repeat On Other Side
	Clear Color Part		Do Not Cement

For a complete list of our newest model kits and more, visit:
round2corp.com

Round 2, LLC
 4073 Meghan Beeler Ct.
 South Bend, IN 46628

CE International Hobbycraft Co.
 272 Avenue Henri-Barbusse
 Marly-lez, Valenciennes 59770, France
 www.hobby-exporter.com

The Green Hornet, related characters, hornet logo and the licensed article TM & ©2023 The Green Hornet, Inc. All Rights Reserved. AMT and design is a trademark of Round 2, LLC. ©2023 Round 2, LLC, South Bend, IN 46628 USA. Product and packaging designed in the USA. Made in China. All rights reserved.