

5. FINAL ASSEMBLIES

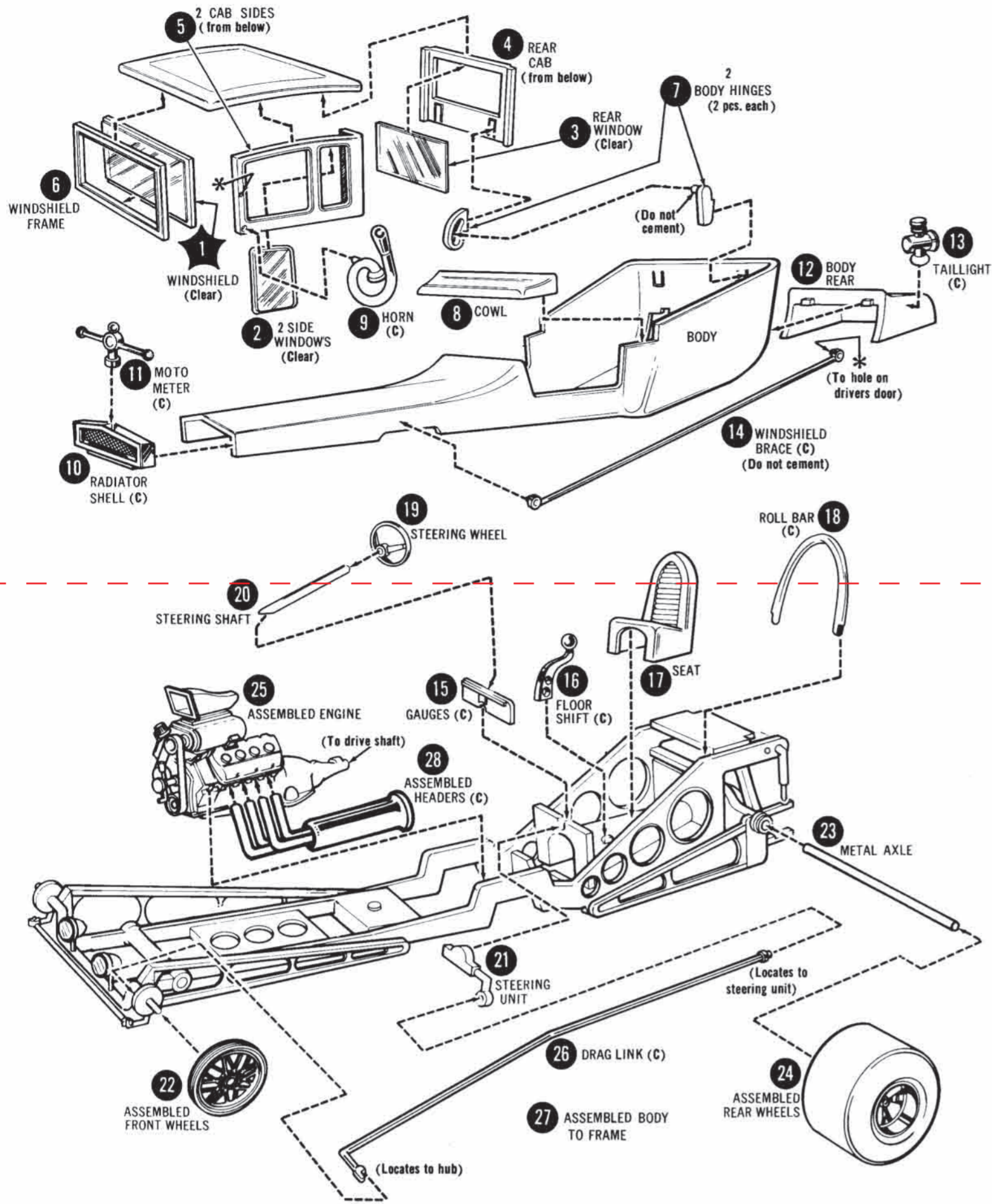

Printed in China • Imprimé en Chine



38631-200

'INFINI-T' LONGNOSE-T

READ THIS BEFORE YOU BEGIN

Look over this instruction sheet carefully before you begin building. Follow the assembly instructions and "test-fit" the parts without cementing. This will familiarize you with the location of the parts.

For the best results, the various sub-assemblies and components should be painted before any "chrome" parts are attached. For example: When attaching "non-chrome" body accessories, it is best to cement them in place and paint the body as a unit.

only paint and cement made for Styrene. Trim excess plastic from parts before joining. When attaching "chrome" parts, scrape plating away where parts are to be joined. Use just enough cement to join parts, and be careful not to smear cement on exposed surfaces.

Built according to the instructions on this sheet, you should have no trouble assembling your kit. Just FOLLOW THE NUMBERS, as parts are numbered in order of assembly. (C) INDICATES "CHROME" PARTS.

I. ENGINE

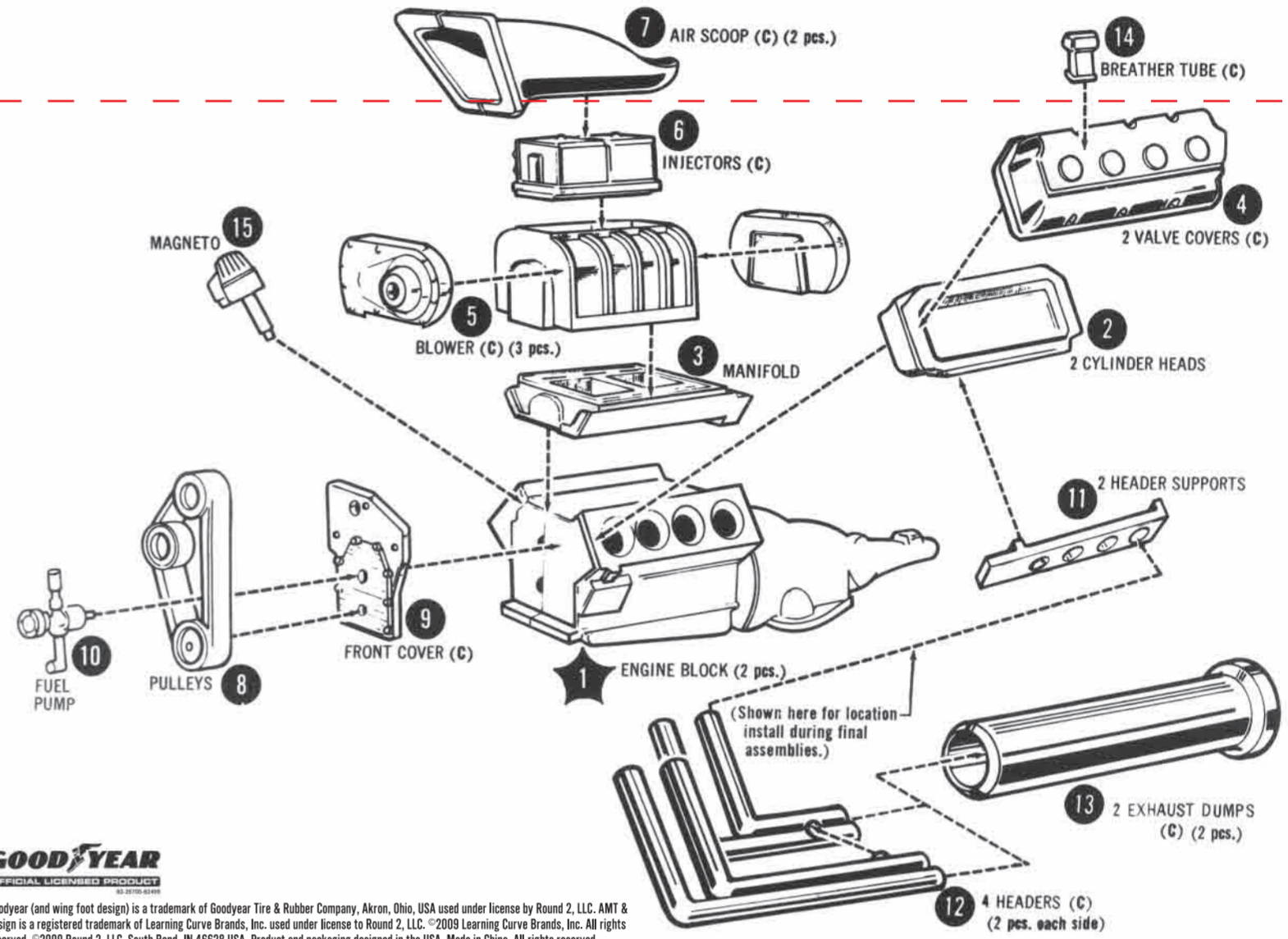

Goodyear (and wing foot design) is a trademark of Goodyear Tire & Rubber Company, Akron, Ohio, USA used under license by Round 2, LLC. AMT & design is a registered trademark of Learning Curve Brands, Inc. used under license to Round 2, LLC. ©2009 Learning Curve Brands, Inc. All rights reserved. ©2009 Round 2, LLC, South Bend, IN 46628 USA. Product and packaging designed in the USA. Made in China. All rights reserved.

2. WHEELS

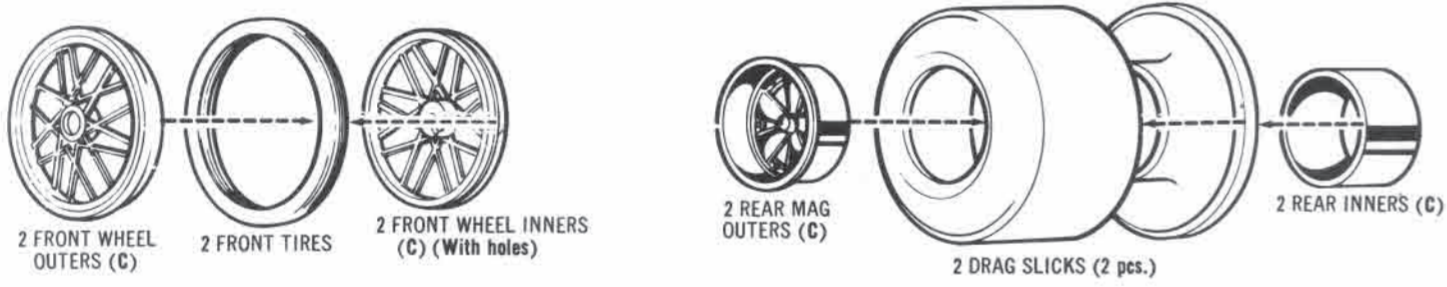

3. CHASSIS

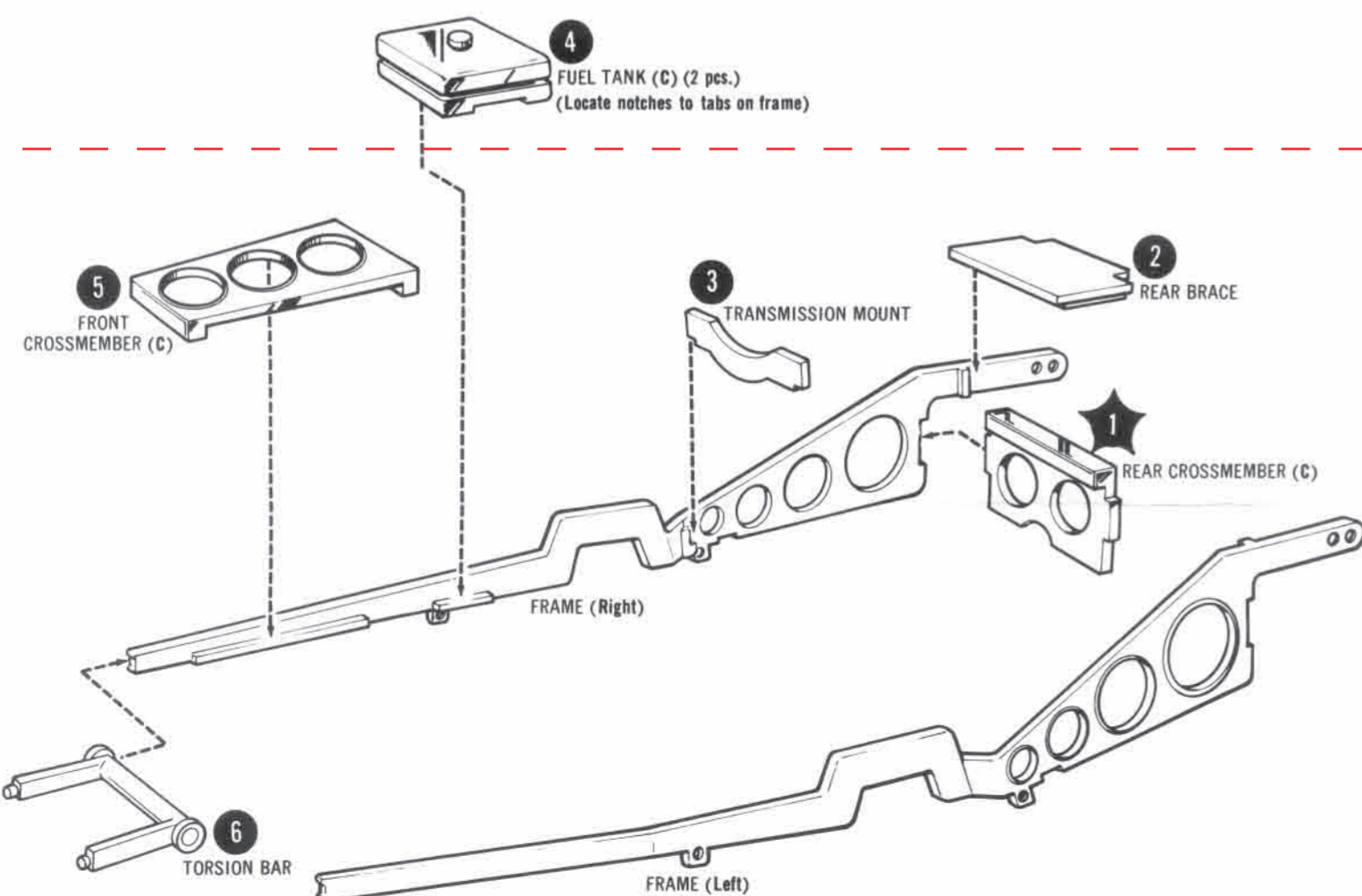

4. CHASSIS

