



a m t **1969 DODGE**
 1/25 SCALE MODEL KIT *Daytona*

**UNITED STATES
 POSTAL SERVICE®**



Auto Art Stamp Series

It was during the late '60s that the NASCAR aerodynamic wars were heating up. Chrysler, long a winner on the big ovals, was getting beat by Ford with its Boss 429 engine in the sleek Torino. Chrysler countered with the Charger 500 which had a flush grille and a "fastback" rear window in place of the standard "tunneled" rear glass. Ford however, had an ace up its sleeve in the form of the Talladega which had a droop nose and a smaller flush grille. Ford continued to dominate. It was back to the drawing board (and wind tunnel) for Chrysler. A sharp-edged shovel nose was found to cut the air cleanly and a rear wing kept the back end down. Chrysler decided to get radical with the rear wing and placed it high above the car (even though a low wing worked just as well). This accomplished two things; one, the trunk could be raised without hitting the wing and two, it made the competition wonder just what Dodge knew that they didn't! They soon found out. The Dodge Daytona of Richard Brickhouse won at Talladega and sent shockwaves through NASCAR-land and of course, Ford.

To qualify as a "stock" car, NASCAR rules stipulate that at least 500 cars must be produced for sale to the general public. Dodge produced the required number and had them on sale in their showrooms on September 1st, 1969. 503 lucky people were able to purchase these winged wonders, many of which still exist today. There were only two engine options, the 375 horse 440 "wedge" or the the 425 horsepower 426 HEMI®. Quite a choice! The stock Daytona came with those mysterious reverse scoops on top of the front fenders. While not really necessary for the street Daytona, the race car version needed them for tire clearance as the slick nose and wing caused enough down-force at speed to cause the tires to rub the inside of the stock fenders. The reverse scoops allowed a hole in the fender for tire clearance.

Now a coveted collectors item, the radical winged Dodge Daytona is the ultimate in late sixties muscle cars. Enjoy your 1/25 scale version of this very special car.

IMPORTANT

Before you begin to assemble your model kit, study the instructions carefully. This will help you to familiarize yourself with the part locations as you proceed. Prior to cementing parts together, be sure to "TEST FIT" them in order to assure proper alignment and also to check for excess "FLASH" that may occur along parting lines. Use a sharp hobby knife or file to remove flash if necessary.

If you wish to paint your model, various sub-assemblies and components should be painted before any parts are attached. During assembly, you may note that the recommended color is stated after the part name.

This model kit is molded from the finest high-impact styrene plastic. Use only paints and cements which are specifically formulated for styrene. Read all labels and warnings carefully. Because the cement will only adhere to bare plastic it is necessary to remove any paint or chrome plating from the area to which the cement is to be applied.

HOBBY KNIFE

Use a sharp hobby knife to remove parts from the trees. Some parts may appear to have an extra "tab" on them; these should be removed.

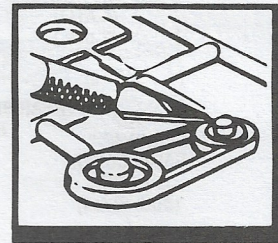

TWEEZERS

Tweezers are handy for holding very small parts during assembly or painting.

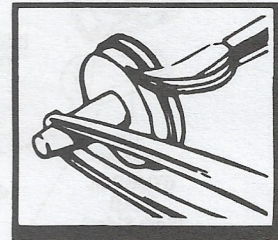

CEMENT

We recommend the use of liquid polystyrene cement. Apply with a fine brush or toothpick. Use cement sparingly or a sloppy job will result.

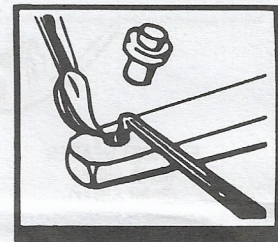

BUILDING TIPS FOR THE ADVANCED MODELER

For the best possible finish, your kit should be painted, even if it is molded in color. Paint should be applied evenly, in several thin coats rather than one heavy coat. The first coat should not completely cover the surface. Each layer should be allowed to thoroughly dry before the next coat is applied. Also, each coat should be "wet sanded" using No.1200 wet or dry sandpaper which is slightly damp; except for the final coat. Be careful not to remove any detail while sanding.

It is important to keep your hands clean when you are working with your model and always wash the parts before painting. This will remove any mold release agent that may have been used during manufacture, body oil from your hands, sanding residue, and dust, which is naturally attracted to plastic by static electricity. Use a mild solution of dishwashing detergent and water. Use a tack rag to dry the parts; DO NOT use paper towels or tissues, since they will

leave lint on the part.

Parting lines and glue joints should be sanded or filed prior to painting and because paint has a tendency to draw away from sharp edges all sharp corners should be filed. Use filler putty designed for plastic to fill small gaps that may occur between parts and to blend contours. This should be done only after the first or "primer" coat of paint is applied.

When painting a two-tone body, the lightest color should be painted first. Use frosted or "magic" tape to mask off the area you do not want painted. After the second color is dry to the touch, the tape can be removed. Use a very fine brush to touch up edges if necessary. If decals are to be added, do so before adding any gloss coat. A gloss coat will help even out the edges between the two colors as well as set the decals.



United States Postal Service, U.S. Mail logo, and stamp art is used with permission under license to Round 2, LLC. © 2021 United States Postal Service. All rights reserved.

Dodge and related logos, vehicle model names and trade dress are trademarks of FCA US LLC and used under license by Round 2 LLC. © 2021 FCA US LLC. Goodyear (and wing foot design) are trademarks of Goodyear Tire & Rubber Company, Akron, Ohio USA used under license by Round 2. AMT and design is a registered trademark of Round 2, LLC. © 2021 Round 2, LLC, South Bend, IN 46628 USA. Product and packaging designed in the USA. Made in China. All rights reserved.

Paint all engine parts HEMI® Orange except as noted.

1A - ENGINE STOCK

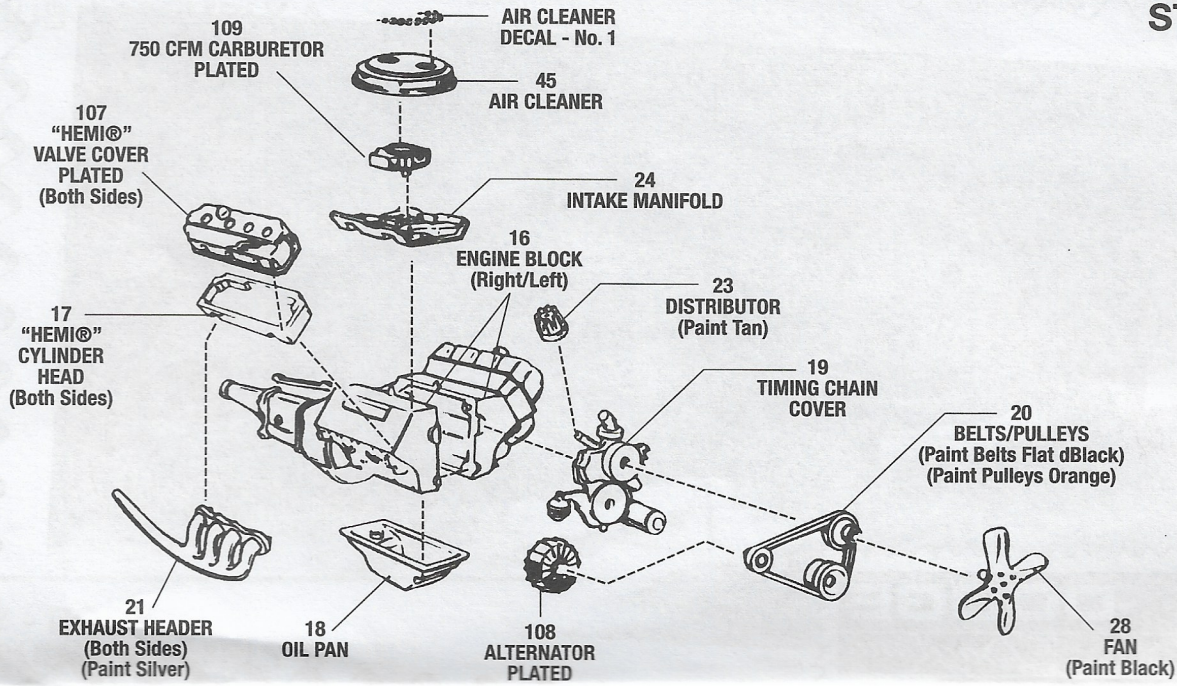

1B - ENGINE CUSTOM

Paint all engine parts HEMI® Orange except as noted.

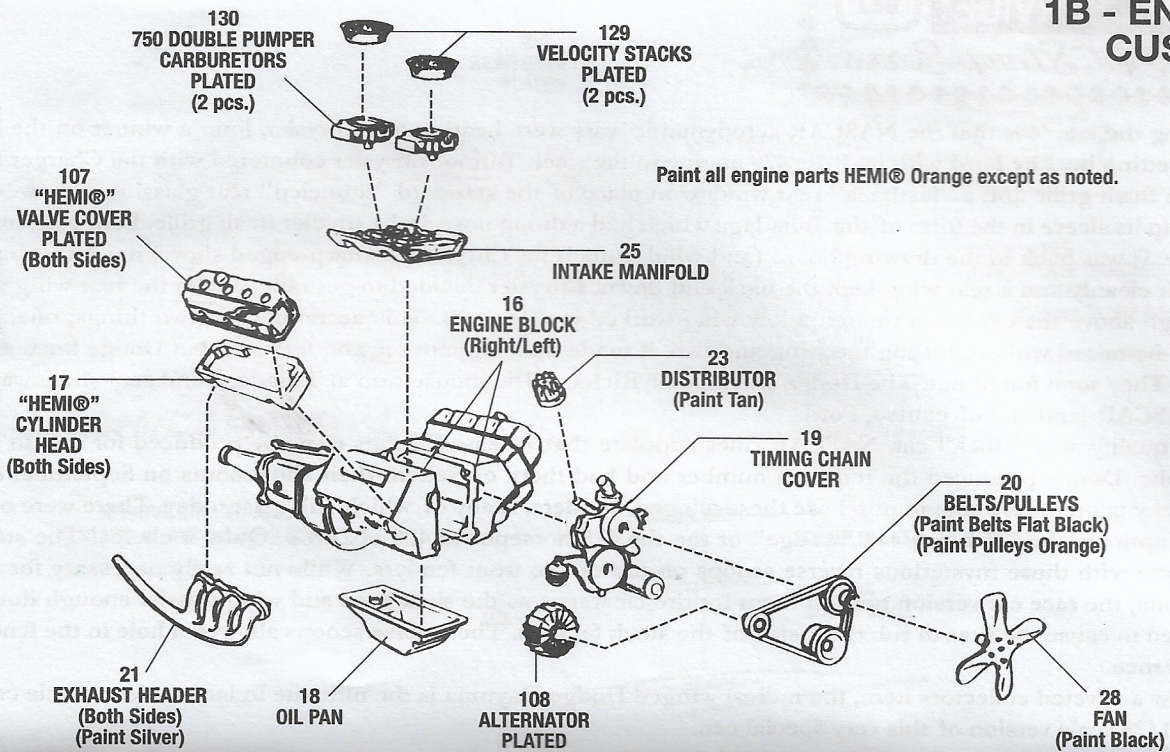

1C - ENGINE COMPETITION

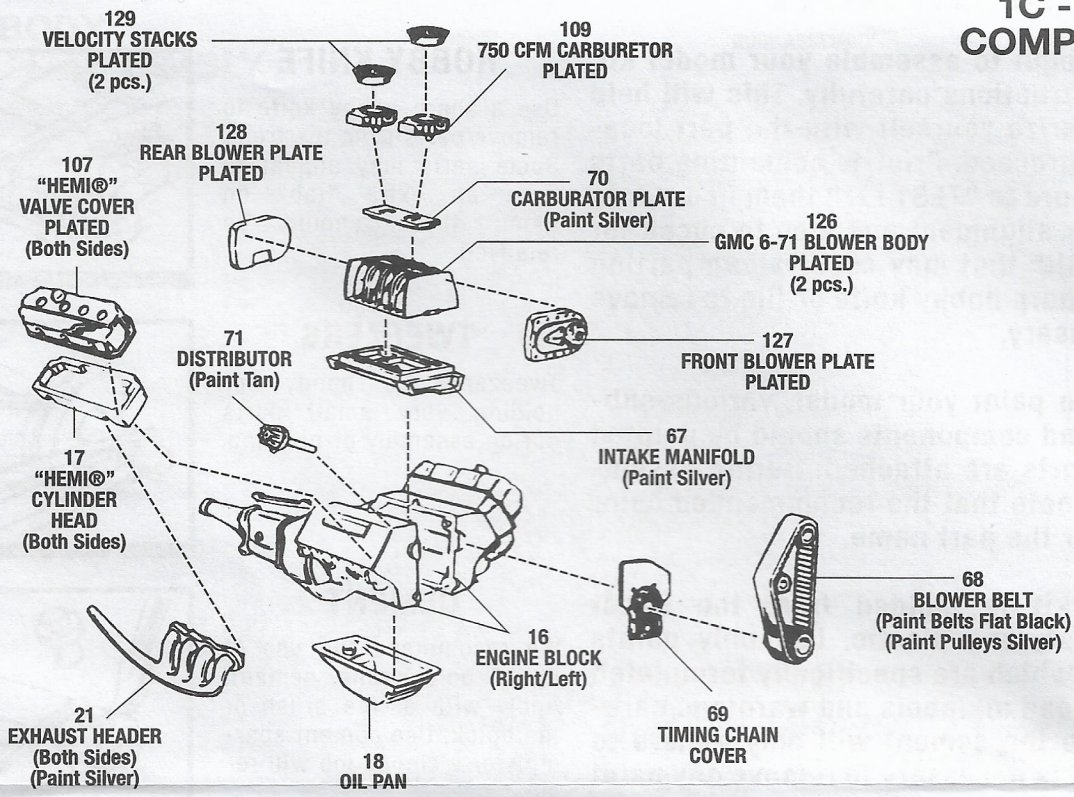

2 - INTERIOR

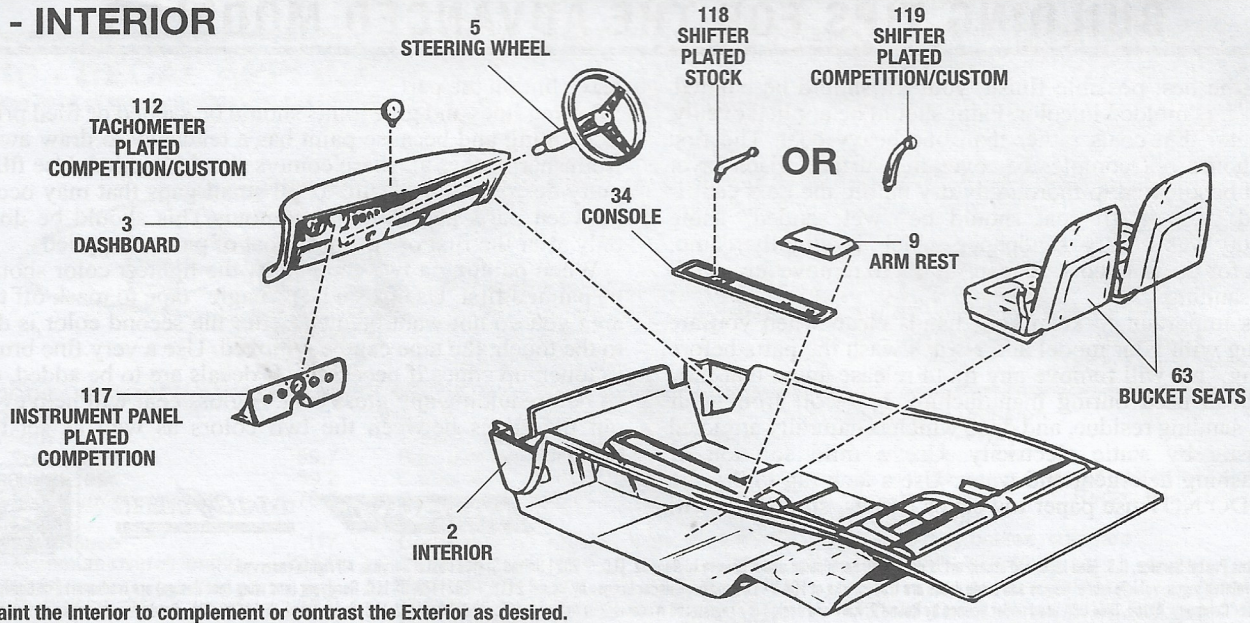

Paint the Interior to complement or contrast the Exterior as desired.

3A - TIRES FRONT

ASSEMBLE TWO SETS

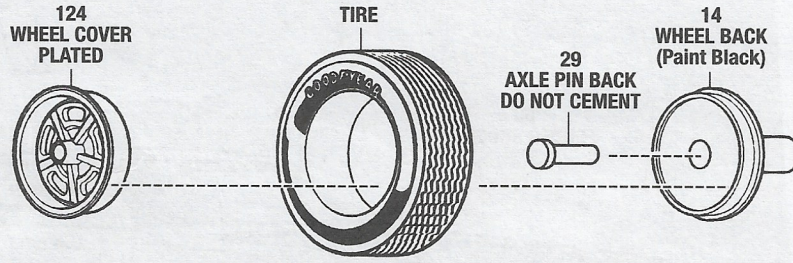

3B - TIRES REAR

ASSEMBLE TWO SETS

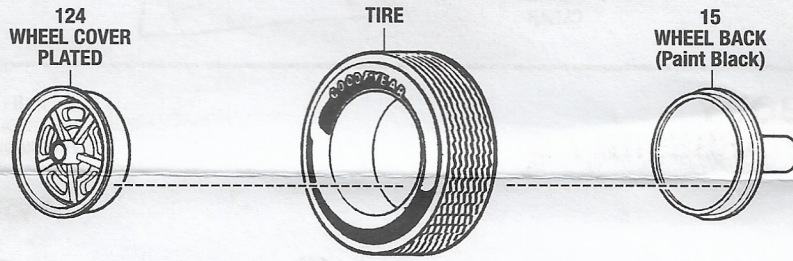

4 - CHASSIS SUB-ASSEMBLY

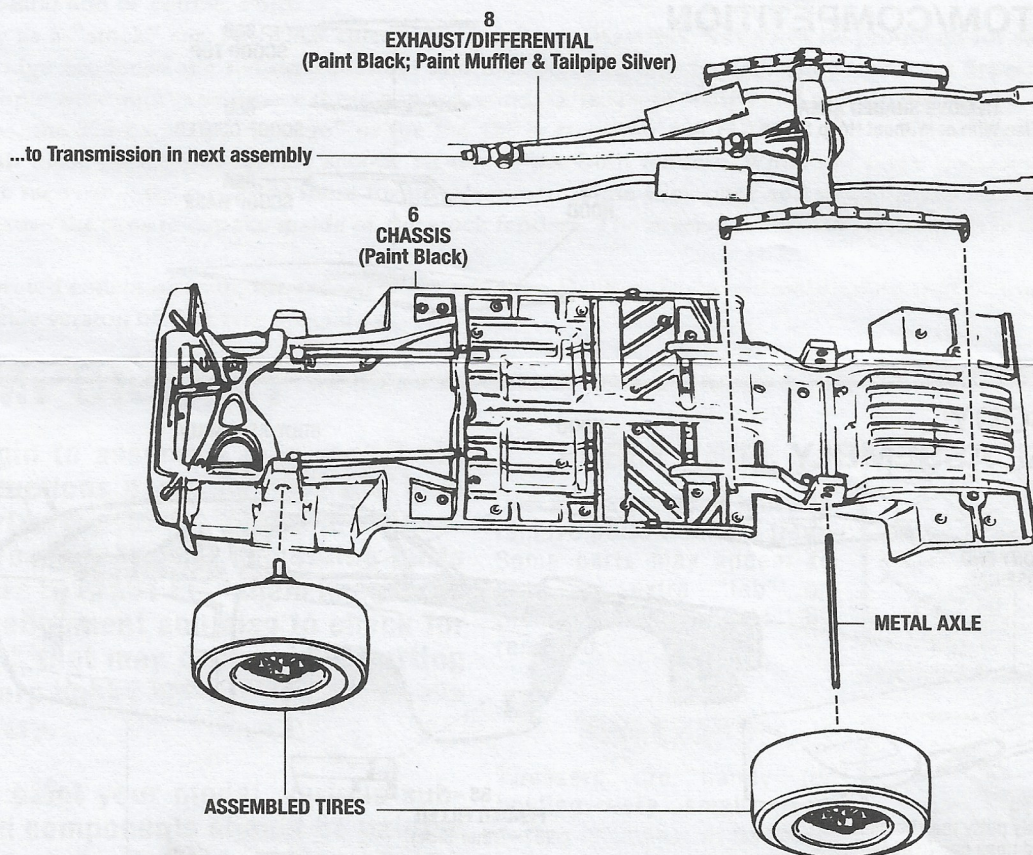

3A - TIRES FRONT

ASSEMBLE TWO SETS

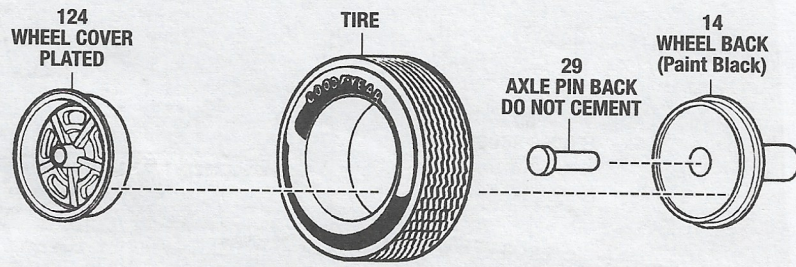

3B - TIRES REAR

ASSEMBLE TWO SETS

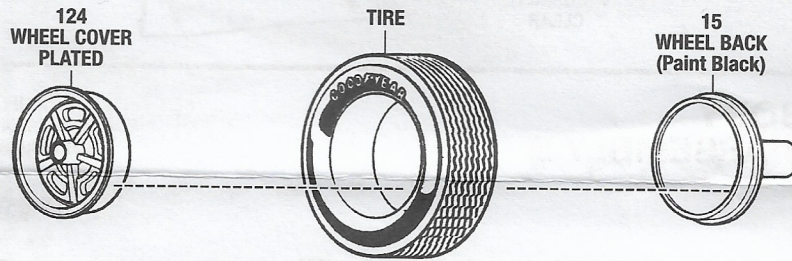

6 - BODY SUB-ASSEMBLY A

**PAIN T BODY BEFORE ASSEMBLY.
SOME FACTORY COLORS INCLUDE:
Burnt Orange, White, Black, Yellow, Beige, Lime Green,
Bright Red, Bright Blue Metallic, Light Blue Metallic**

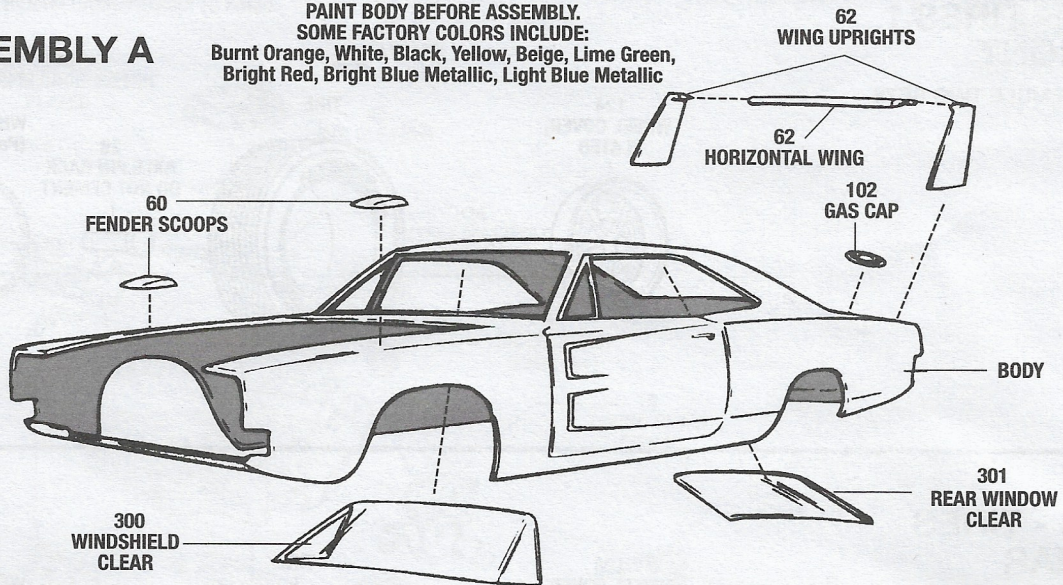

7 - BODY SUB-ASSEMBLY B

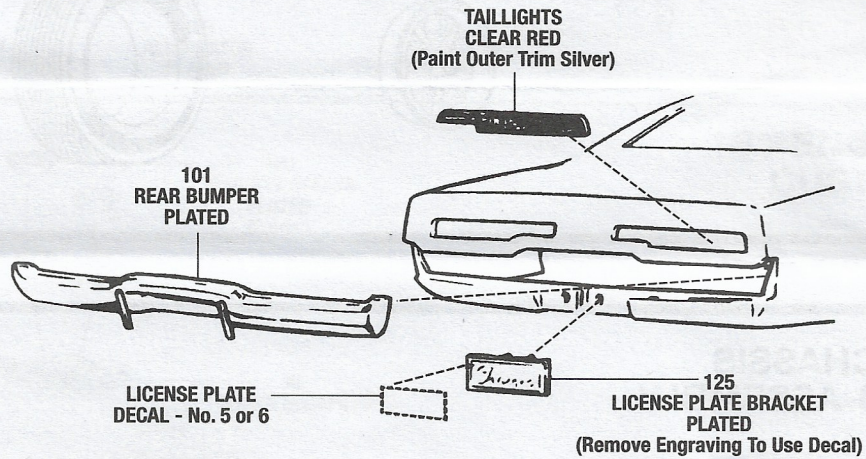

8 - HOOD CUSTOM/COMPETITION

**REMOVE SHADED AREA
Use With or Without Hoop Scoop**

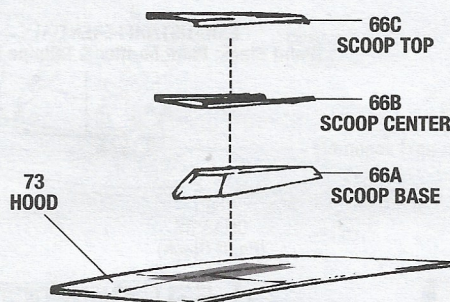

9 - BODY FINAL ASSEMBLY

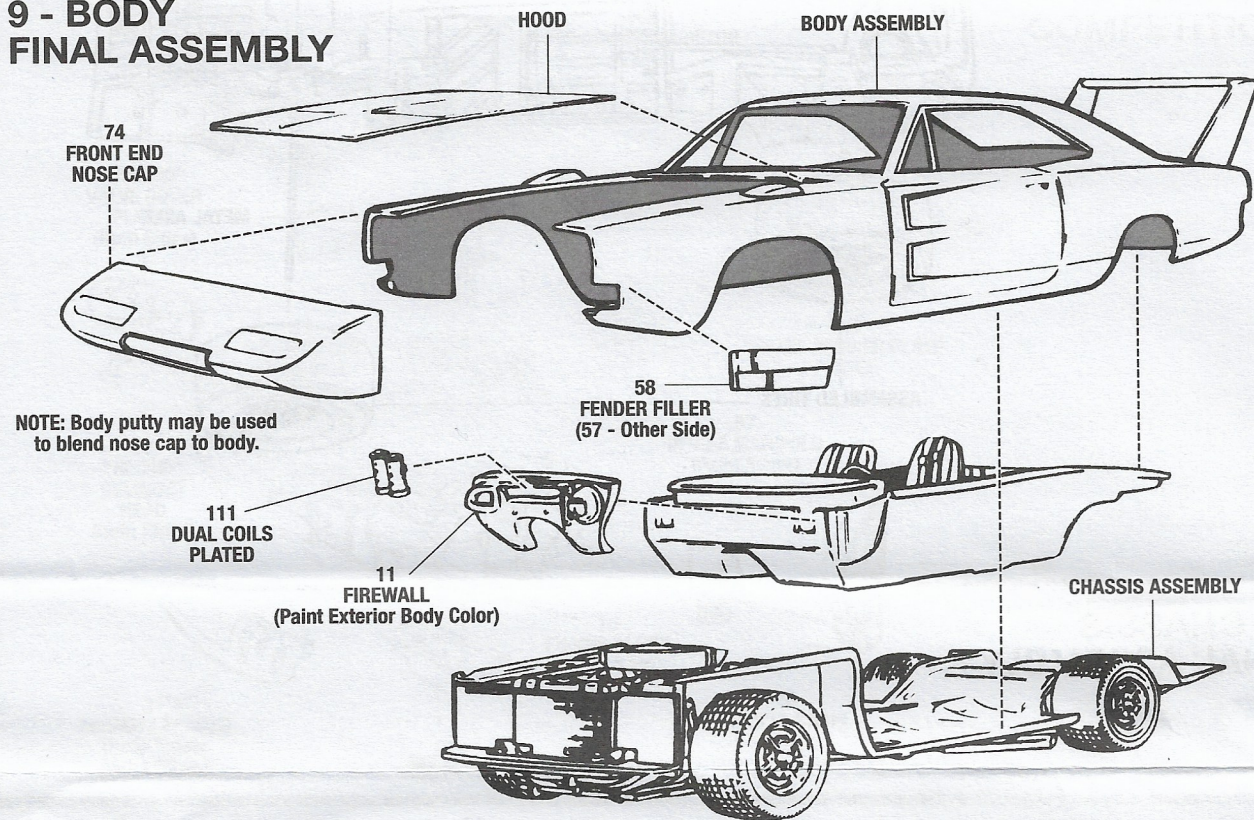

10 - DECAL APPLICATION

See back of the decal sheet for application instructions.

Paint Spoiler to Match Decal

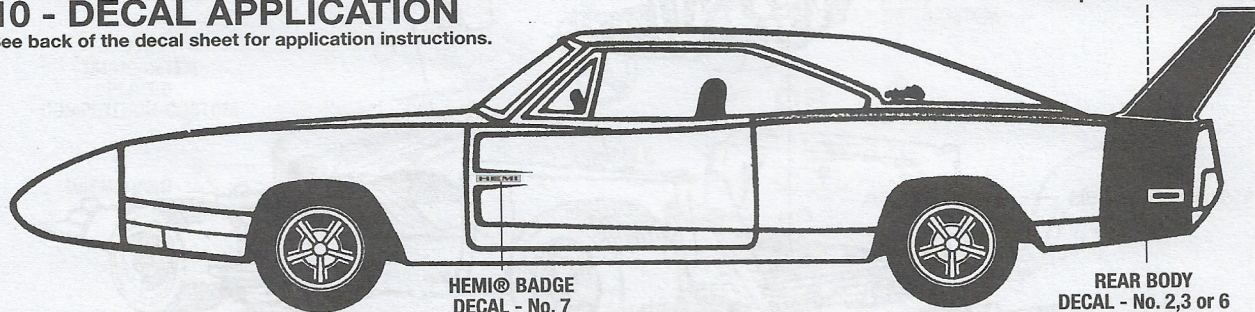

DODGE CHARGER DAYTONA (REPRESENTED BY KIT VERSION)

Dimensions

Width	
Track, front	59.7
Track, rear	59.2
Maximum overall width	76.6
Length	
Wheelbase	117
Maximum overall length	226.5
Height	
Overall height	53.0

Engine

Type & no. of cyls.	426 cid V-8 HEMI®
Bore and stroke	4.25 x 3.75
Carburetor	One 4-bbl.
Compression ratio	10.25:1
Exhaust system	Dual
Crankcase	4 qts. - 5qts. w/oil filter
Coolant	17 qts.
Horsepower @ rpm	425 @ 5000
Torque (lbs.-ft.) @ rpm	490 @ 4000
Fuel recommended	Premium

Chassis/Suspension

Body/Frame type	Unitized
Front suspension	Torsion bars
Rear suspension	Asymmetrical leaf springs
Steering system	Recirculating ball gear

Brakes - Drum

Heavy-duty brakes, standard (automatic adjusting)	
Front	11.0 x 3.0
Rear	11.0 x 2.5