

FINAL ASSEMBLIES

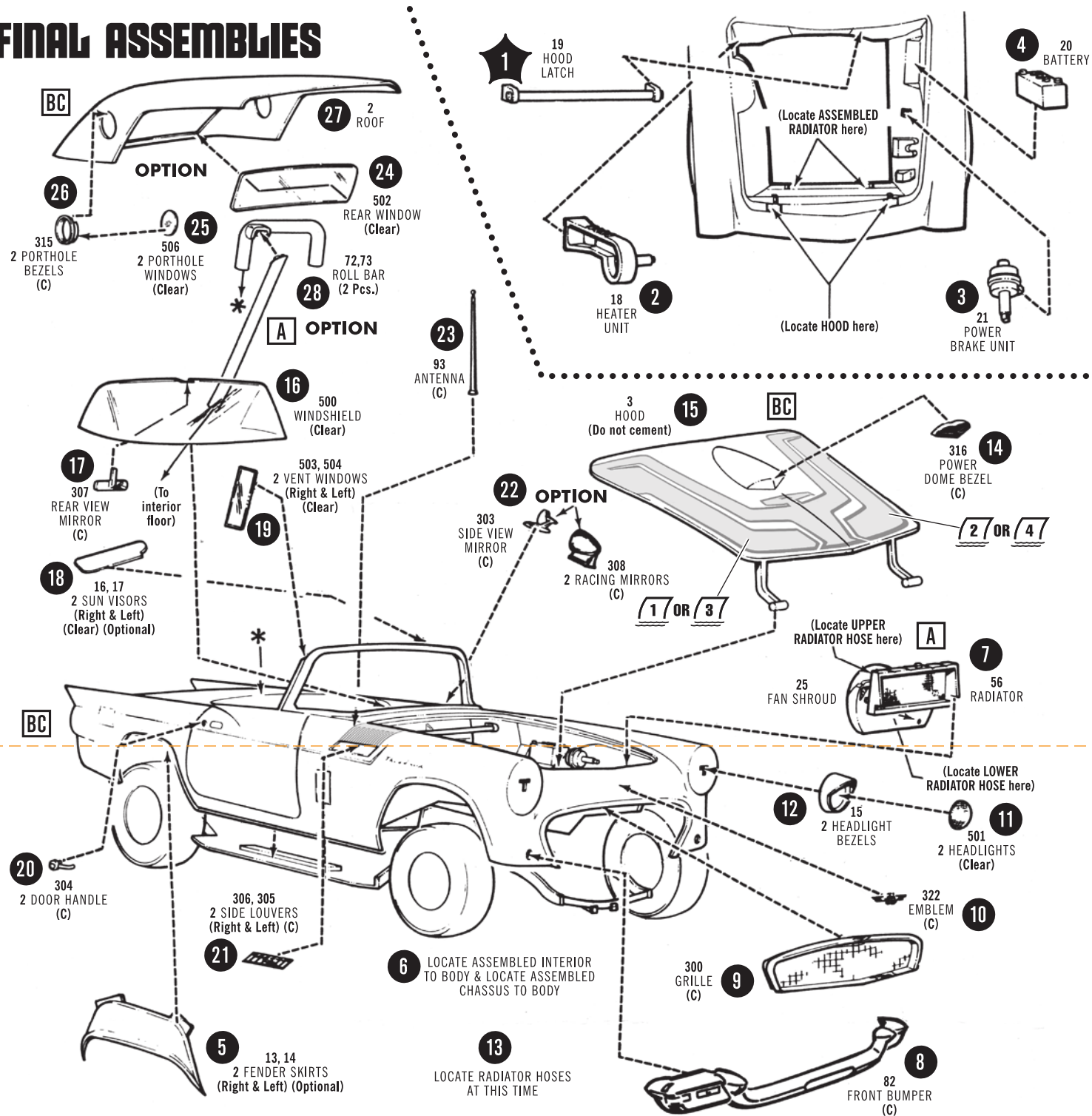

REAR VIEW

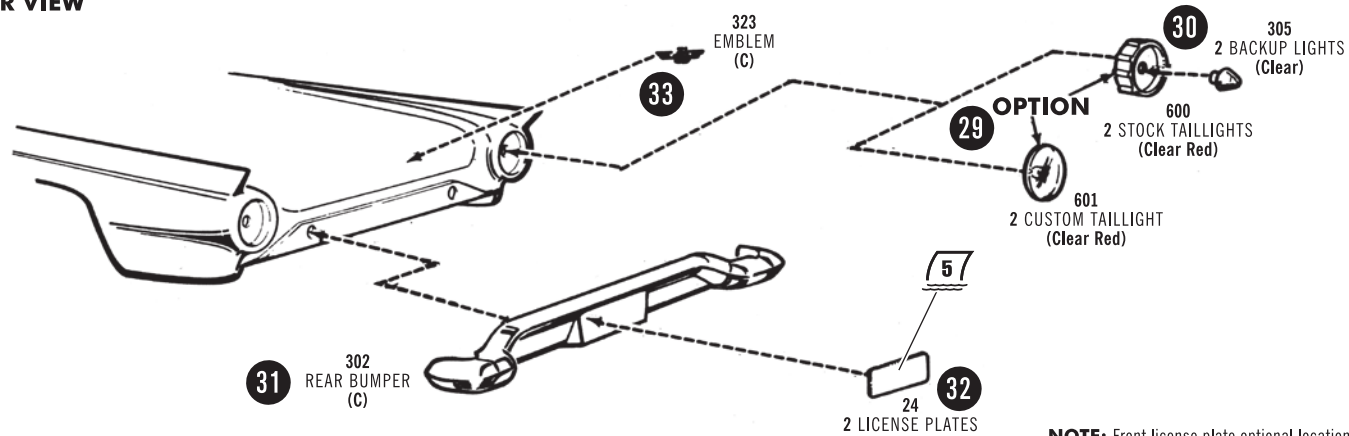

NOTE: Front license plate optional location.

'57



HARDTOP/CONVERTIBLE



A1206-200



READ THIS BEFORE YOU BEGIN

This kit may be built more than one way. Look over this instruction sheet carefully before you begin building. You may decide to combine parts from the different versions shown, or use parts from other AMT® kits. After you've planned your car, follow the assembly instructions and "TEST FIT" the parts without cementing. This will familiarize you with the location of parts.

For best results, the various sub-assemblies and components should be painted before any "CHROME" parts are attached. For example: When attaching "NON CHROME" engine parts, it is best to cement them in place and paint as a unit. **"CHROME" PARTS ARE INDICATED BY (C).**

AMT® kits are molded from the finest high-impact styrene plastic. Use only paint and cement made for styrene. Trim excess plastic from parts before joining. When attaching "CHROME" or painted parts, scrape plating or paint away where parts are to be joined. Cement all parts unless otherwise indicated by the instructions. Use just enough cement to join parts and be careful not to smear cement on exposed surfaces.

Built according to the instructions on this sheet, you should have no trouble assembling your kit. Just **FOLLOW THE NUMBERS** as the instructions are numbered in order of assembly.

PAINT COLORS

A Black	H Aluminum	O Transparent Red	V Dark Blue	BC Body Color
B Flat Black	I Steel	P Orange	W Transparent Blue	IC Interior Color
C Semi-Gloss Black	J Brass	Q Yellow	X Lt. Green	▲ Semi-Gloss
D White	K Gold	R Tan	Y Dark Green	△ Gloss
E Flat White	L Amber	S Brown	Z Gray	▲ Metallic
F Silver	M Transparent Amber	T Lt. Blue	AA Purple	
G Chrome (Bright Silver)	N Red	U Med. Blue	BB Beige	

SYMBOLS

- 1** Assembly Sequence
- 49** Part Number
- 17** Apply Decal



Ford Motor Company Trademarks and Trade Dress used under license to Round 2, LLC. All rights reserved. Distributed by Round 2 LLC. Goodyear (and winged foot design) and Blimp are trademarks of The Goodyear Tire & Rubber Company used under license by Round 2, LLC, South Bend, IN 46628. ©2020 The Goodyear Tire & Rubber Company. AMT and design and Round 2 and design are registered trademarks of Round 2, LLC. ©2020 Round 2, LLC, South Bend, IN 46628 USA. Product and packaging designed in the USA. Made in China. All rights reserved.

ENGINE

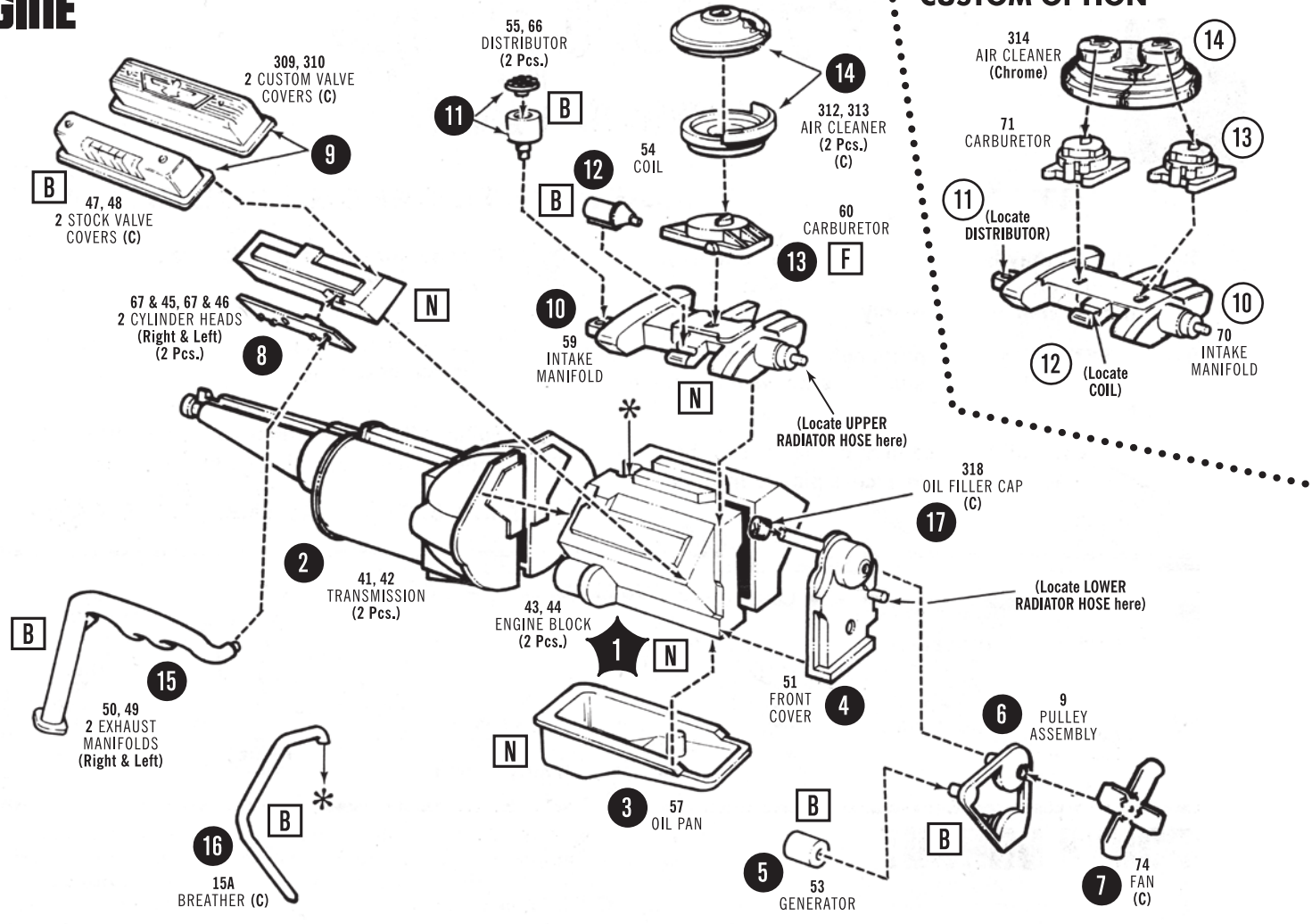

WIRING

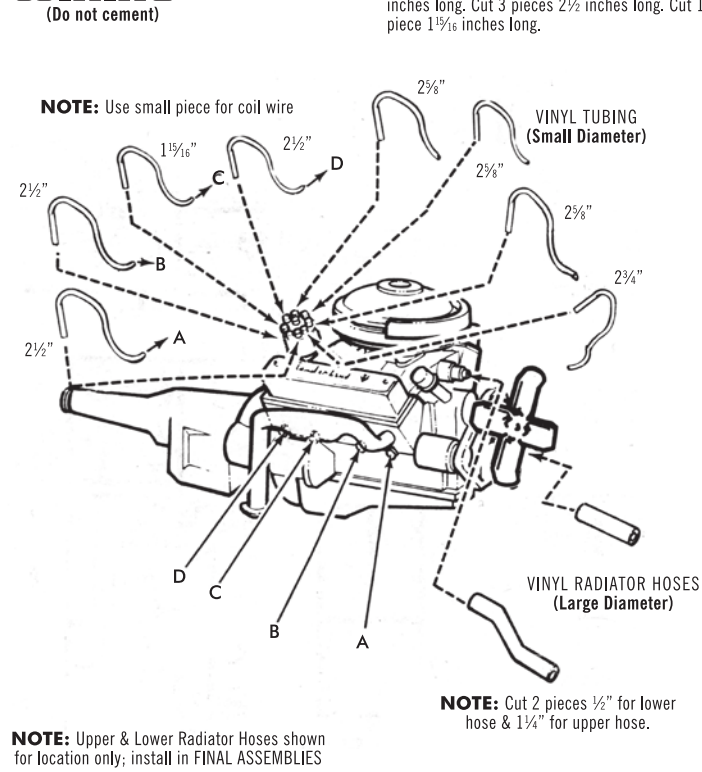

INTERIOR

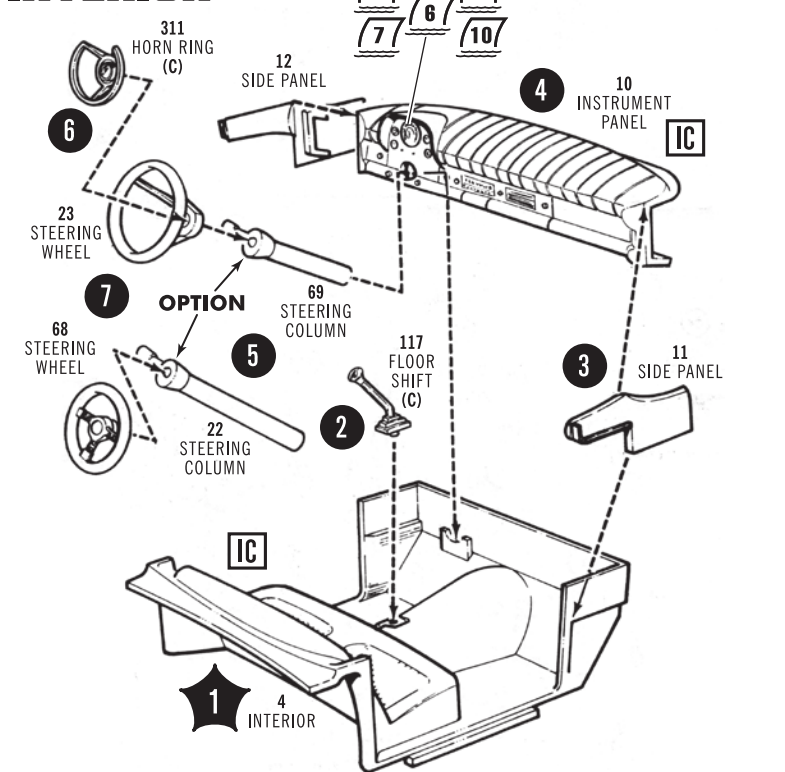

WHEELS

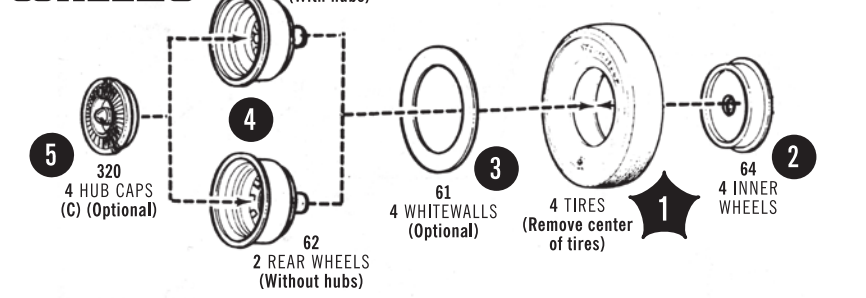

CHASSIS SHOWN UPSIDE DOWN

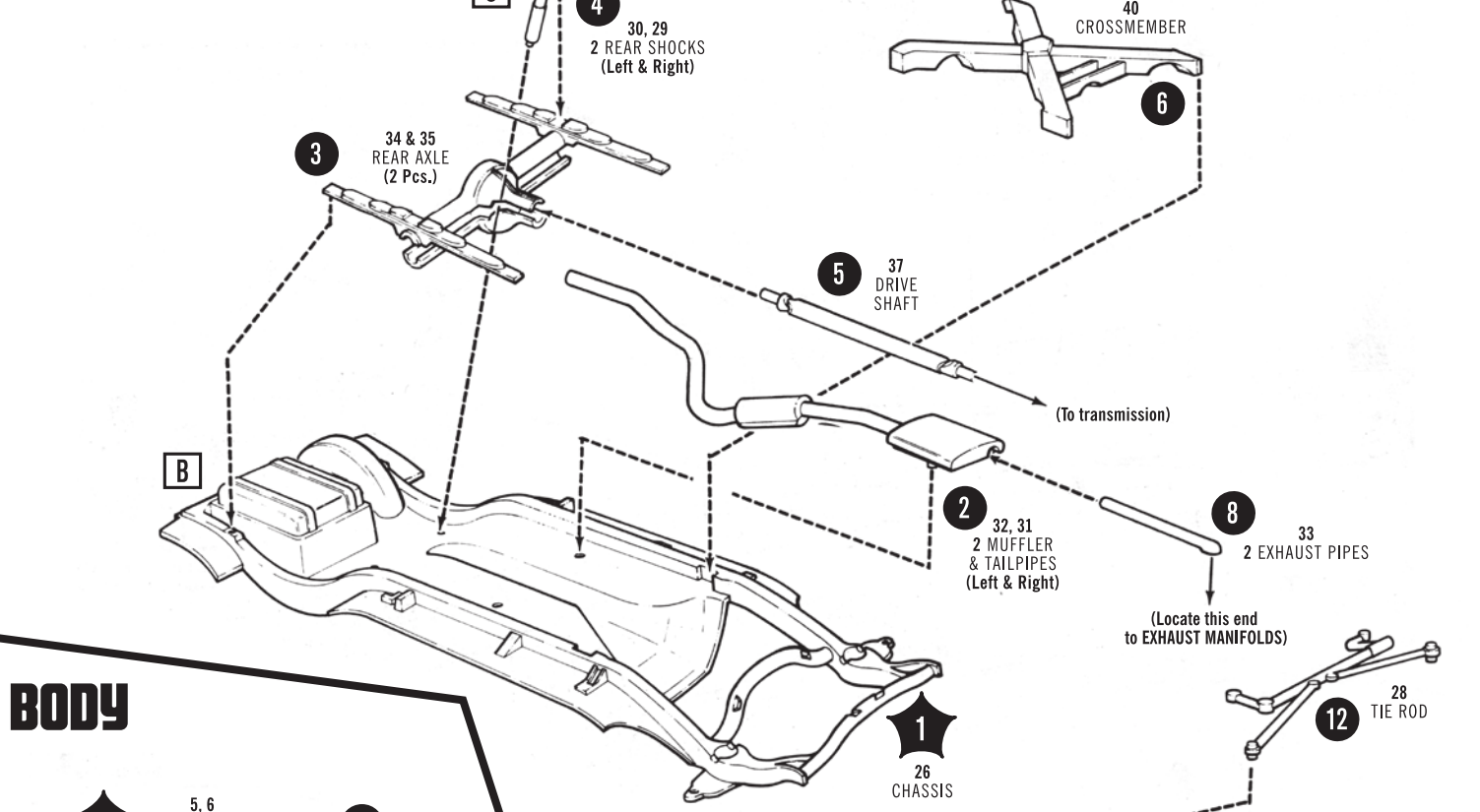

BODY

