

P-40E WARHAWK



WARRANTY.....

Top Flite Models guarantees this kit to be free of defects in both material and workmanship at the date of purchase. This warranty does not cover any component parts damaged by use or modification. In no case shall Top Flite's liability exceed the original cost of the purchased kit. Further, Top Flite reserves the right to change or modify this warranty without notice.

In that Top Flite has no control over the final assembly or material used for final assembly, no liability shall be assumed nor accepted for any damage resulting from the use by the user of the final user-assembled product. By the act of using the user-assembled product the user accepts all resulting liability.

If the buyer is not prepared to accept the liability associated with the use of this product, he is advised to immediately return this kit in new and unused condition to the place of purchase.



**Top Flite Models
P.O. Box 721
Urbana, IL 61801**

Technical Assistance - Call (217)398-8970

READ THROUGH THIS INSTRUCTION BOOK FIRST. IT CONTAINS IMPORTANT INSTRUCTIONS AND WARNINGS CONCERNING THE ASSEMBLY AND USE OF THIS MODEL.

TABLE OF CONTENTS

METRIC CONVERSION CHART	2
INTRODUCTION	3
Precautions	3
DIE PATTERNS	4,5
DECISIONS YOU MUST MAKE	6
Engine and Mount Selection	6
Retracts	6
Wheel Selection	6
Flaps.....	6
Drop Tank	6
Static Display Propeller	6
Supplies and Tools	7
Other Items Required	7
Common Abbreviations	7
Types of Wood.....	7
TIPS FOR COMPETITION- MINDED MODELERS	7
Deviations from scale	7
Scale Documentation	8
Scale Retracts and Doors	8
GET READY TO BUILD	8
Build the Horizontal Stabilizer	8
Build the Fin	11
Build the Elevators.....	12
Build the Rudder.....	13
BUILD THE WING	15
Install the Center Rib (W-1)	18
Preparing for the Flaps.....	19
Join the Wing Panels.....	21
Fixed Landing Gear Assembly	22
Mount the Landing Gear.....	23
Sheet the Bottom of the Wing	24
Sheet the Top of the Wing	25
Wing Completion	26
Build the Flaps.....	27
Build the Ailerons	28
BUILD THE FUSELAGE	29
Build the Fuselage Top.....	32
Mount the Wing to the Fuselage	36
Attach the Stab and Fin.....	37
Build Fuselage Bottom	37
Build Top Cowling	38
Build the Wing Fillet.....	39
Build the Wing Belly Pan	41
Fit the Flaps.....	41
Build the Cowl	42
Build the Landing Gear Pods.....	44
Fuel Proofing	45
Balance the Airplane Laterally.....	45
Retracts	45
FINISHING	45
Colors	46
Finishing Techniques.....	46
Apply the Decals	48
Draw on the Panel Lines	48
Final Clear Coat	49
Exhaust Stacks.....	49
Hinging	49
Final Engine Installation	49
Final Control Hardware Hookup	50
Cockpit Finishing	51
Install Receiver, Switch, and Battery	52
Balance Your Model.....	52
Final Hookups and Checks	53
PREFLIGHT	53
AMA SAFETY CODE	54
FLYING	54
2-VIEW DRAWING	56

METRIC CONVERSIONS

In. x 25.4 = mm (conversion factor)

1/64"	= .4 mm
1/32"	= .8 mm
1/16"	= 1.6 mm
3/32"	= 2.4 mm
1/8"	= 3.2 mm
5/32"	= 4 mm
3/16"	= 4.8 mm
1/4"	= 6.4 mm
3/8"	= 9.5 mm
1/2"	= 12.7 mm
5/8"	= 15.9 mm
3/4"	= 19 mm
1"	= 25.4 mm
2"	= 50.8 mm
3"	= 76.2 mm
6"	= 152.4 mm
12"	= 304.8 mm
15"	= 381 mm
18"	= 457.2 mm
21"	= 533.4 mm
24"	= 609.6 mm
30"	= 762 mm
36"	= 914.4 mm

WARNING! THIS IS NOT A TOY!

The model you will build from this kit is not a toy! It is capable of serious bodily harm and property damage. **IT IS YOUR RESPONSIBILITY AND YOURS ALONE** - to build this kit correctly, properly install all R/C components to test fly the model and fly it **ONLY** with experienced, competent help in accordance with all safety standards as set down in the Academy on Model Aeronautics Safety Code. It is suggested that you join the AMA to become properly insured before you attempt to fly the model. **IF YOU ARE JUST STARTING R/C MODELING, CONSULT YOUR LOCAL HOBBY SHOP OR WRITE TO THE ACADEMY OF MODEL AERONAUTICS TO FIND AN EXPERIENCED INSTRUCTOR IN YOUR AREA.**

Academy of Model Aeronautics
5151 E. Memorial Drive
Muncie, IN 47302 (800)435-9262

INTRODUCTION

Thank you for purchasing the **Top Flite® GOLD EDITION™ P-40E Warhawk**.

The Top Flite P-40E is an excellent sport scale model that is just as "at home" sport flying as it is in competition. Its exact scale outline allows you to detail it out and take it into serious competition. Its modern construction and refined aerodynamics, incorporating features such as built-in washout and computer designed airfoils that progressively change from root to tip, give you a plane that will build straighter and fly better than warbirds of the past.

The **Gold Edition** Warhawk is approximately 1/7th scale. The exact scale ratio is 1:6.9. The trim scheme used on the model pictured on the box duplicates that used by the legendary Flying Tigers. Three large sheets of decals are included to help you duplicate this scheme. You can cover your P-40 with olive drab, tan, and grey MonoKote®, but, to get truly authentic results, you must paint the model. Helpful information on painting can be found in the **Finishing Section**.

The Top Flite Warhawk makes an excellent scale competition aircraft. The front end of this model has been specially engineered to allow you to completely hide most engines in the recommended range. The large cowling will even completely hide an O.S. 1.20 Surpass. The cowling is designed to use the scale cooling air entrance and exit to cool your model engine. Engines such as the O.S. .61 SF (2c) and O.S. 1.20 Surpass (4c) have been flown in the Warhawk and required no additional cooling. A special 2-cycle muffler with headers to fit several of the recommended engines has been specifically designed for and tested in the P-40. This muffler provides good sound reduction while fitting entirely inside the cowling. More information on the recommended engines and related items can be found in the **Engine and Mount Selection Section**.

Please inspect all parts carefully before starting to build! If any parts are missing, broken or defective, or if you have any questions about building or flying this model, please call us at (217) 398-8970 and we'll be

glad to help. **If you are calling for replacement parts, please look up the part numbers and the kit identification number (stamped on the end of the carton) and have them ready when calling.**

PRECAUTIONS

1. You must build the plane **according to the plans and instructions**. Do not alter or modify the model, as doing so may result in an unsafe or unflyable model. In a few cases the plans and instructions may differ slightly from the photos. In those instances you should assume the plans and written instructions are correct.
2. You must take time to **build** straight, true, and strong.
3. You must use a proper R/C **radio** that is in first class condition, the correctly sized **engine** and correct **components** (fuel tank, wheels, etc.) throughout your building process.
4. You must properly **install** all R/C and other components so that the model operates properly on the ground and in the air.
5. You must **test** the operation of the model before the first and each successive flight to insure that all equipment is operating, and you must make certain that the model has remained structurally sound. Be sure to check external nylon clevises often and replace if they show signs of wear.
6. You must **fly** the model **only with the competent help** of a well experienced R/C pilot if you are not already an experienced R/C pilot at this time.

DIE-CUT PATTERNS

P406F01

1 PER KIT

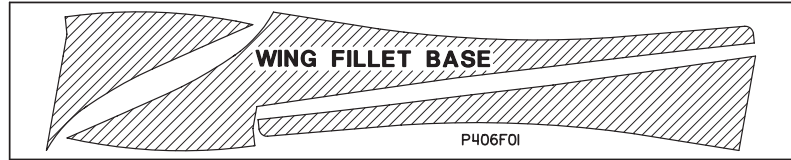

1/32" X 24-7/8" X 5" PLY

P406F02

1 PER KIT

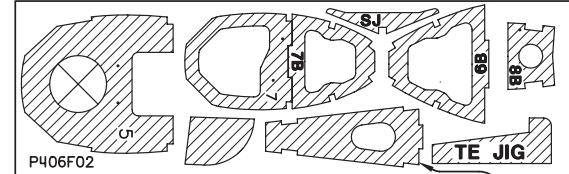

1/8" X 5-1/2" X 17-3/4" PLY

STAB SUPPORT CRUTCH

P406F03

1 PER KIT

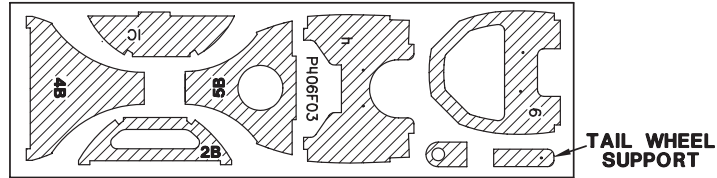

1/8" X 5-1/2" X 17-3/4" PLY

TAIL WHEEL SUPPORT

P406F04

1 PER KIT

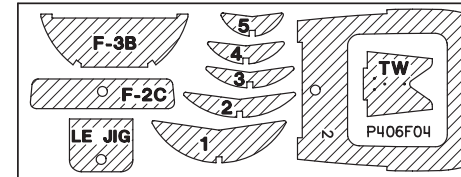

1/8" X 5-1/2" X 14-1/2" PLY

P406F05

1 PER KIT

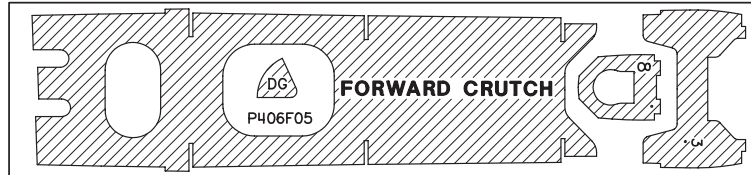

1/8" X 5-1/2" X 23-5/8" PLY

P406F06

1 PER KIT

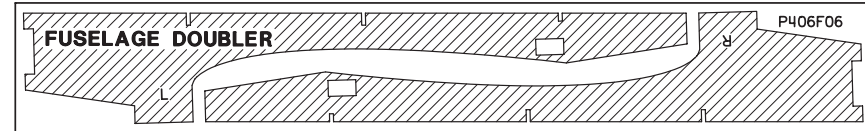

1/8" X 4-1/8" X 27" PLY

P406F07

1 PER KIT

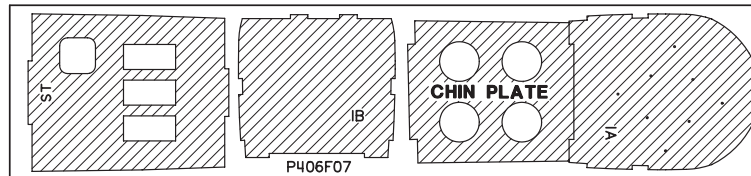

1/8" X 5-1/2" X 23-5/8" PLY

P406F08

2 PER KIT



3/32" X 3" X 24" BALSA

P406F10

1 PER KIT

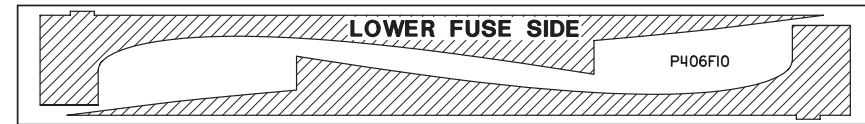

1/8" X 3-3/4" X 27" BALSA

P406F09

1 PER KIT

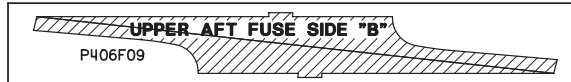

3/32" X 2-3/4" X 18" BALSA

P406S03

1 PER KIT

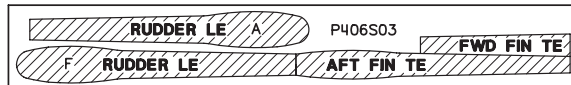

3/16" X 2-3/4" X 18" BALSA

P406S02

1 PER KIT

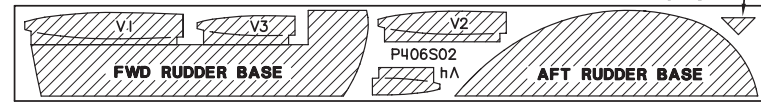

3/32" X 3" X 24" BALSA

FIN TRIANGLE

DIE-CUT PATTERNS

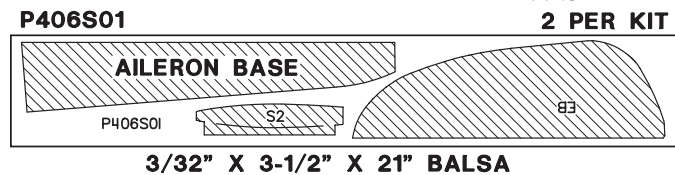
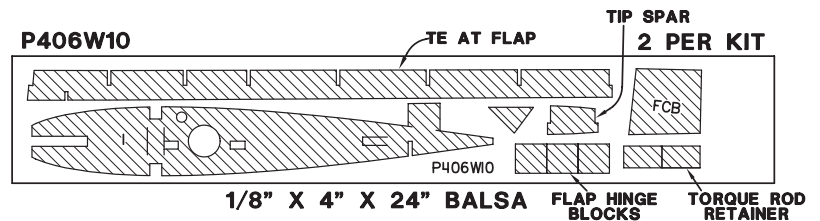
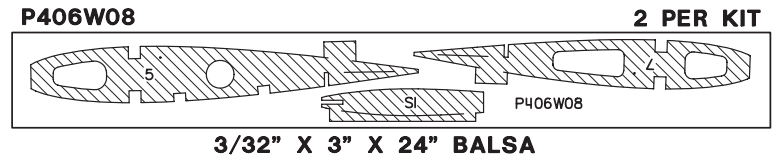
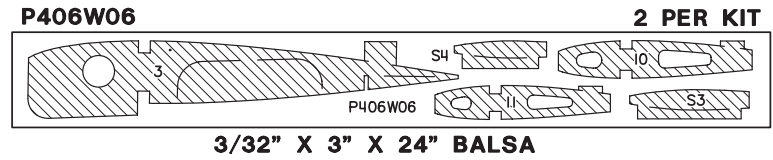
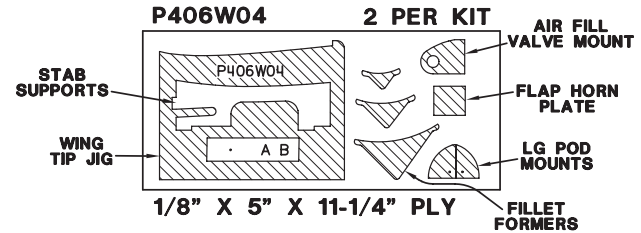
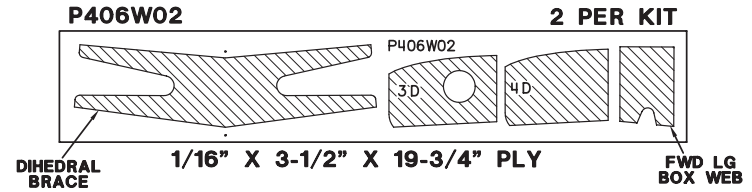
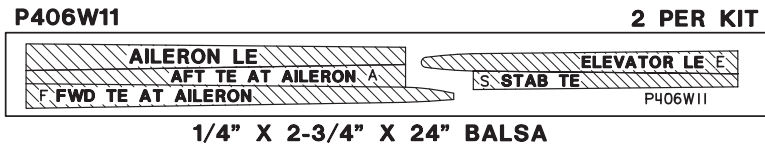
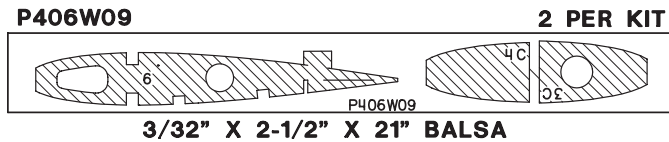
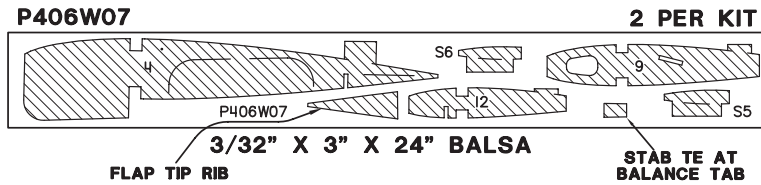
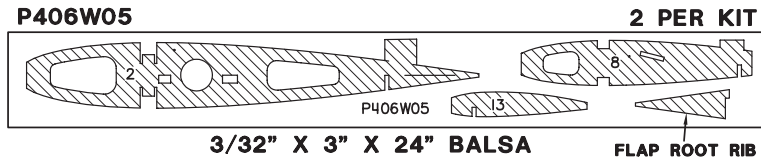
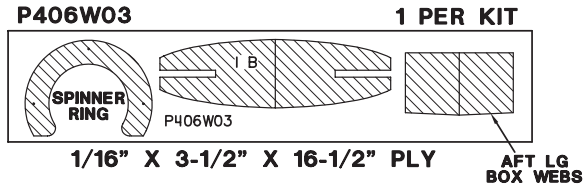
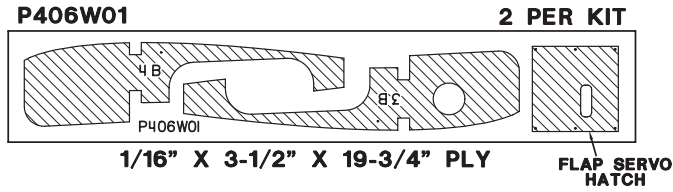

NOTE: We, as the kit manufacturer, can provide you with a top quality kit and great instructions, but ultimately the quality and flyability of your finished model depends on how **you** build it. Therefore, we cannot in any way guarantee the performance of your completed model, and no representations are expressed or implied as to the performance or safety of your completed model.

Remember: Take your time and follow directions to end up with a well-built model that is straight and true.

DECISIONS YOU MUST MAKE EARLY IN THE BUILDING SEQUENCE

ENGINE AND MOUNT SELECTION

The recommended engine size range is as follows:

.60 to .91 cu. in. **2-cycle**

.90 to .120 cu. in. **4-cycle**

The Warhawk will fly well with any of the recommended engines. The 4-Cycle engines and most .90 2-Cycle engines will turn a larger prop at lower RPM's. This is often desirable for scale realism. Many .60 2-Cycle engines produce about as much horsepower as the popular .90 2-Cycle engines and will fly the Warhawk fine. If you use a .60 2-Cycle, a Schnuerle ported engine is preferred. The prototype P-40 with all of the options, including flaps, retracts, drop tank, paint etc., has been flown with an O.S. .61 SF. This combination works fine and gives very realistic

scale power. Most modelers are accustomed to a larger power reserve and would probably prefer more power if they load up their P-40 with all of the extras.

Even though the P-40 is designed to house the engine inverted, a modeler desiring a more utilitarian setup can mount his engine with the cylinder head sticking out the right side of the model. The same engine centerline should be used.

The mount selection is up to you. If you use an O.S. 1.20 4-cycle, the plans show (and the firewall is spaced for) a **J-tec No. JT-122 SV** (JTEG8450). The included mount will hold many 2-Cycle engines such as the O.S. .61 SF.

A special muffler and header is available that will fit inside your cowling. It is primarily designed for 2-cycle engines mounted inverted.

*Header for O.S. .61SF (TOPQ7920)

*Header for SuperTigre S61K & S75K (TOPQ7925)

*Muffler for above (TOPQ7915)

RETRACTS

The choice whether or not to use fixed gear or retracts is up to you. Retracts offer good looks and great flight realism with the added expense and complication. The model is designed to use the Robart #615 (ROBQ1815) rotating retracts, as these offer the easiest installation and most reliable operation. More information on retracts is found in the "Tips for Competition Minded Modelers" section and in the construction sequence. For item numbers, see "Other Items Required", page 7.

WHEEL SELECTION

The true scale tire size is 4-5/8". The **recommended** range of tire sizes is **3-1/4" to 4"**. The 4" wheels fit comfortably into the wing when

retracted. If you use fixed gear, you may choose to use the smaller tires to reduce drag in the air. Robart 4" (ROBQ1537) main wheels are very close to scale appearance for a P-40. A 1-1/4" tail wheel is scale and recommended.

FLAPS

This model is designed to incorporate split flaps that are very scale. They are not difficult to assemble, but they do require good craftsmanship if they are to fit well. They add a good deal to the model's flight characteristics and scale appeal while causing no bad effects. No trim correction of any kind is needed when they are used with the recommended throws. The flaps add drag and lift to the model on landing approaches, which gives the plane a very steady, locked-in feel. The flaps require one channel, a Y-harness, and two standard or mini servos. They are highly recommended for those who wish to install them. More information on the use of the flaps may be found in the **Flying Section**.

DROP TANK

P-40s in combat used drop tanks most of the time. Top Flite has made a correctly sized, vacuum-formed drop tank available for your warbird. The tank comes with a release mechanism and is easy to assemble and install. The drop tank will add a great deal of realism to your Warhawk. Part #TOPQ7900

STATIC DISPLAY PROPELLER

When displaying your model, nothing adds more realism than a good looking scale propeller. Top Flite has a 3-bladed scale propeller available for your P-40. Remember, this propeller is for static display only; do not attempt to run the engine with it mounted. Part # TOPQ7907

SUGGESTED SUPPLIES AND TOOLS

We recommend only Top Flite Supreme™ glues for the assembly of our models.

- 2 oz. CA [thin] (TOPR1003)
- 2 oz. CA+ [thick] (TOPR1008)
- 6-Minute Epoxy (TOPR1040)
- 30-Minute Epoxy (TOPR1043)
- Hand or Electric Drill
- Drill Bits: 1/16", 3/32", 1/8", 5/32", 3/16", 13/64", 1/4", 17/64"
- Sealing Iron (Top Flite) (TOPR2100)
- Heat Gun (Top Flite) (TOPR2000)
- Hobby Saw (X-acto Razor Saw)
- X-acto Knife, #11 Blades
- Pliers
- Screw Drivers
- T-Pins
- String
- Straightedge with length graduations
- Masking Tape (Required for construction)
- Sandpaper (coarse, medium, fine grit)*
- T-Bar Sanding Block (or similar)
- Waxed Paper
- Lightweight Balsa Filler such as Hobbico® HobbyLite™ (HCAR3400)
- 1/4-20 Tap, Tap Wrench
- Isopropyl Rubbing Alcohol (70%)
- Dremel Moto Tool or similar (optional)
- Razor Plane

***NOTE:** On our workbench, we have four 11" T-Bar sanders, equipped with #50, #80, #150 and #220-grit sandpaper. This setup is all that is required for almost any sanding task. Sanding blocks can be made from balsa for sanding hard to reach spots. We also keep some #320-grit wet-or-dry sandpaper handy for finish sanding before covering.

OTHER ITEMS REQUIRED

- Four to seven channel radio with 4 to 8 servos.
- Engine (see page 6)
- Propellers (see engine instructions for recommended sizes).
- Pilot figure (1/7th or 2" scale recommended)
- 4" P-40 Top Flite spinner
#TOPQ5401 red, #TOPQ5400 white
- Fuel Tank (Most 10 to 16 oz. tanks will fit)
- 3-1/4" to 4" Main Wheels (2) (see page 6)
- 1-1/4" Tail wheel
- 3/16" Wheel Collars (4 for fixed gear main wheels)
- 3/32" Wheel Collars (2 for tail wheel)
- Top Flite Super MonoKote (2 rolls) Clear (see **Finishing Section**)
- Paint (see **Finishing Section**)
- Silicone Fuel Tubing
- Latex Foam Rubber Padding (1/4" thick)

Optional:

- Drop Tank.....TOPQ7900
- Static Prop.....TOPQ7907
- Retracts.....Robart #615
- Air Control Kit.....Robart #188
- Robostruts.....Robart #650
- Engine Mount.....(see page 6)

COMMON ABBREVIATIONS USED IN THIS BOOK AND ON THE PLANS:

- deg. = Degrees
- Elev = Elevator
- Fuse = Fuselage
- LE = Leading Edge (front)

- LG = Landing Gear
- Lt = Left
- Ply = Plywood
- Rt = Right
- Stab = Stabilizer
- TE = Trailing Edge (rear)
- " = Inches

TYPES OF WOOD

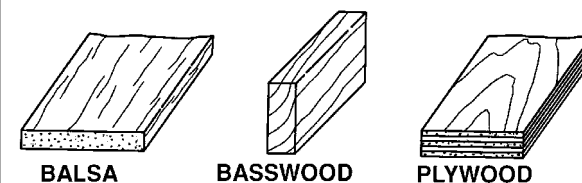

TIPS FOR COMPETITION-MINDED MODELERS

DEVIATIONS FROM SCALE

The rudder hinge line has been simplified to allow you to use conventional model hinging techniques. The elevator hinge line near the tip of the stab was changed slightly to simplify the elevator shape.

If you plan to compete with the trim scheme shown on the box, here are a few things to consider:

The full size P-40 that was duplicated is a P-40E which was restored and is still in existence. It matches the Koku Fan 3-view very well, with a few exceptions.

The most serious deviation is in the rear portion of the canopy. The rear window recesses (White ABS plastic in the model kit) were removed from the full scale aircraft. This is presumably to allow for a passenger. If you plan to enter serious competition, you will probably want to modify your kit to eliminate these panels. We chose to have the kit build as a stock P-40E.

The P-40 was equipped with a variety of guns. The guns in the photos differ from the ones on the 3-view. This is not a problem; just duplicate the ones in the photos as we did on our prototypes using 3/16" brass tubes.

Always work from the photos of the full size aircraft and the proper 3-view drawing when finishing your model because that is what you will use for documentation.

SCALE DOCUMENTATION

This model was designed using the Koku-Fan 3-view drawings as the reference for outline. This fact makes it preferable to use those drawings for scale documentation. The drawings and many Warhawk photo packs are available from:

Scale Model Research
3114 Yukon Ave
Costa Mesa, CA 92626
(714) 979-8058

The trim scheme shown on the box is from photo pack #588 (54 pictures \$35) -or- #588a (16 pictures \$16) +\$3 S&H

SCALE RETRACTS AND DOORS

The retract landing gear pivot location shown on the plans is correct. The stance of the model (and strut length) shown with the gear down is correct. Keep in mind that the Warhawk's gear,

like that in most modern aircraft, compresses under the weight of the aircraft and extends when the aircraft takes off. This fact means that the rigid struts commonly used on models will not fold into the scale locations. The normal way to deal with this problem in models is to set up the model to have the proper stance, and then have the wheel retract into a position short of the scale location. The only other reasonable way to overcome this problem is to use oleo struts (such as Robart Robostruts) that have springs light enough to compress under the weight of the model and thus function in a scale fashion.

The full scale P-40 uses landing gear doors on the pods. We have not made these functional on any of our models so we cannot offer any help on implementing these.

GET READY TO BUILD

NOTE: When you see "CA," use super thin Supreme glue. When you see "CA+," use thick Supreme glue.

- 1. Unroll the plan sheets. Re-roll the plans inside out to make them lie flat.
- 2. Remove all parts from the box. As you do, identify the name of each part by comparing it with the plans and the parts list at the back of this book. Using a felt tip or ball point pen, write the part **name** or **size** on each piece to avoid confusion later. Use the die-cut patterns shown on pages 4 and 5 to identify the die-cut parts and mark them **before** punching out. Save all scraps. If any of the die-cut parts are difficult to punch out, do not force them! Instead, first cut around the parts with a sharp hobby knife. After punching out the die-cut parts, use your T-Bar or sanding block to **lightly** sand the edges to remove any die-cutting irregularities.

- 3. As you identify and mark the parts, separate them into groups, such as **fuse** (fuselage), **wing**, **fin** and **stab** (stabilizer), and **hardware**.

BUILD THE HORIZONTAL STABILIZER

- 1. Work on a flat surface over the plans covered with waxed paper. Refer to the plans to identify the parts and their locations.

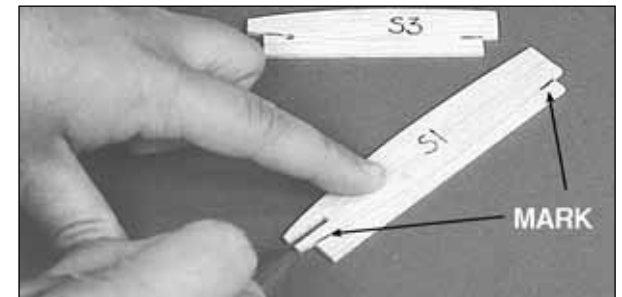

- 2. Punch out both sets of the die-cut 3/32" balsa ribs **S-1** to **S-6**. There is a jig tab on the bottom edge of each of these ribs. If any of these break off, carefully glue them back on with CA. Lightly sand any imperfections. You may need to finish cutting the notch in the forward portion of S-1 for the **Stab Joiner (SJ)** with a knife. Use a pen to mark the extensions of the bottom edge of the ribs across the fore and aft ends of the jig tabs. These will help you when you trim off the jig tabs later.
- 3. The stab **Trailing Edges (S)** are die-cut from 1/4" balsa. Since some crushing may happen when die-cutting wood of this thickness, they are supplied slightly long and can be trimmed. True up the ends of these pieces with sandpaper. Also true up the top and bottom edges of these pieces with a T-bar.

- ❑ 4. The stab and fin **Leading Edges (LE's)** are cut to length from the 1/4" x 30" tapered balsa stock. Cut two pieces about 1/4" longer than the length shown on the plans for the stab LE. 

***HINT:** Bevel the front edge of the stab and fin ribs to match the sweep angle of the LE stock. This will give you a better fit and a stronger glue joint.*

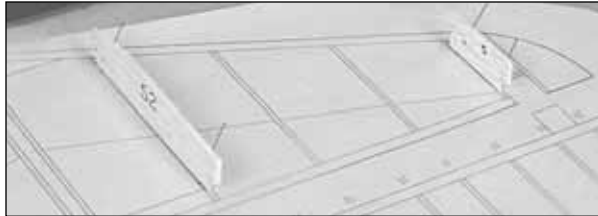

- ❑ 5. Starting with the right half of the stab, pin ribs **S-2** and **S-5** to the building board over their locations on the plans.

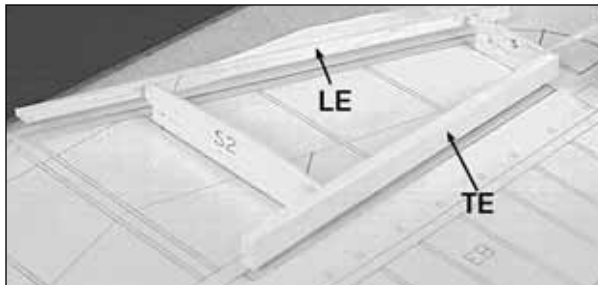

- ❑ 6. Center the **LE** vertically on the front edge of ribs S-2 and S-5. Glue it in place with CA.

- ❑ 7. Center the **TE** vertically on the back edge of ribs S-2 and S-5. Glue it in place with CA.



- ❑ 8. Glue ribs **S-3** and **S-4** in their places. All of the jig tabs should rest on the work surface.

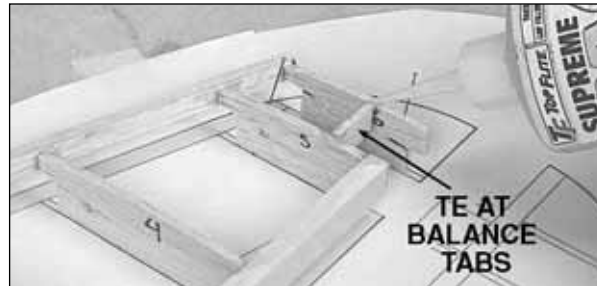

- ❑ 9. Glue rib **S-6** to the LE. Glue the die-cut 3/32" balsa **TE at Balance Tab** between ribs S-5 and S-6 at the location shown on the plans.

- ❑ 10. Trim the LE and TE near the stab center so they match the endpoints shown on the plans.



- ❑ 11. Repeat steps 5 through 10 to build the **left** half of the stab. The left half of the stab is built beside the right half and the two halves do not touch for now.

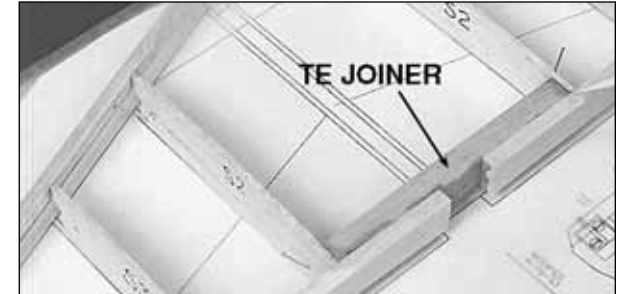

- ❑ 12. Trim the 3/8" x 9/16" x 4-1/2" hard balsa stab **TE Joiner**, if necessary, to fit between the S-2's. **Securely** glue it to the stab TE's and the S-2's using CA.



- ❑ 13. Check the fit of the die-cut 1/8" plywood **Stab Joiner (SJ)** and adjust if required for a good

fit to the stab LE's. Place the Stab Joiner into the slots in the two S-1's and work the whole assembly into position. Make sure all parts are properly aligned and the S-1 rib jig tabs contact the work surface. Glue in the Stab Joiner and the S-1's using CA.

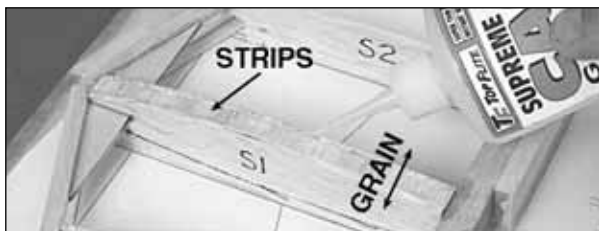

14. Cut two 1/4" wide cross grain strips off the end of a 1/16" x 3" x 30" wing sheet. Glue these strips between the two S-1 ribs flush with their top edges. These strips will reinforce the stab skins where they join at the center and strengthen the stab.

15. Use CA+ to reinforce any glue joints that do not look strong.

16. Carefully remove the stab from the building board but try not to damage the jig tabs, as they will be useful until after the top of the stab is sheeted.

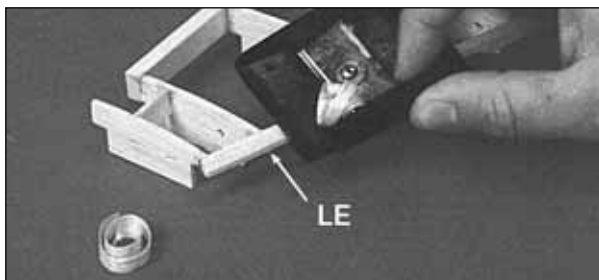

17. Use a razor plane and a sanding block to cut down the top surface of the LE (particularly toward the tip) until it is even with the ribs. Sand

the TE, if required, to have a smooth transition from the ribs.

TIPS FOR MAKING WING AND STAB SKINS

A. Wherever practical, pre-join the balsa sheets to make a "skin" before attaching them to the structure.

B. Many modelers like to sort the wood so they can put the best wood with the most even grain structure on the top of the wing and stab.

C. Make your skin larger than needed to allow for misalignment. On a large surface like the wing, 3/8" extra is suggested.

D. To make skins the following steps are recommended:

1. True up the edges of the sheets with a metal straight edge and a sharp knife or a "T-Bar" sanding block.

2. Test fit the sheets together to make sure they match well.

3. Glue the sheets together with CA over a flat surface covered with waxed paper. A quick wipe of the joint with a fresh paper towel will remove excess glue and make sanding easier. Mark the poorest surface that you think should be the inside of the sheet with an "I".

4. Place the skin on a large flat surface and sand it with a large flat sanding block and fresh, sharp 220 paper.

5. Trim the perimeter of the sheet to even things out.

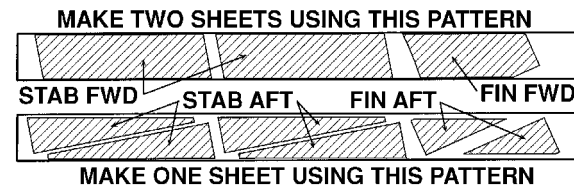

18. Make four stab skins from three 1/16" x 3" x 30" balsa wing sheet pieces. See the sketch for the proper layout on the wood. Refer to the plans for the exact shapes and sizes, but remember to make the skins slightly oversize.

19. Pin the stab structure onto the flat building surface. Test fit the skins over the structure. Make sure the skins meet well at the center. Adjust them if necessary.



20. Apply an even bead of CA+ to the upward facing edges of the structure. Place the skin in its proper position and press it firmly down until the glue has set. Take your time here as a strong joint is critical. Repeat this step for the other top skin.

21. Remove the stab from the building board. Trim off the jig tabs with a sharp knife. Trim and

blend the LE and TE to the ribs as you did before and sand the bottom edges of the ribs lightly with a T-bar sander. Check all glue joints, adding glue as necessary

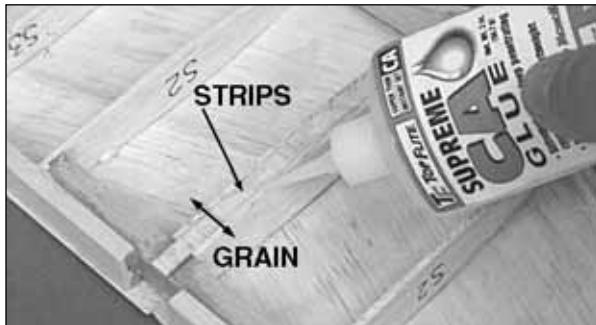

22. Cut two 1/4" wide strips off the end of a 1/16" x 3" x 30" wing sheet. Glue these strips between the two S-1 ribs flush with their bottom edges.

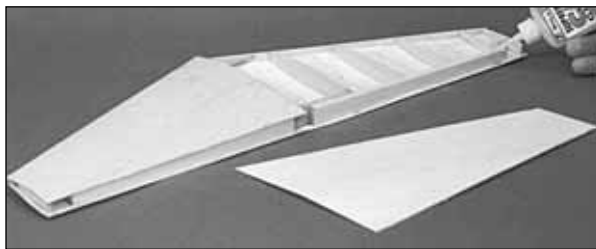

23. It is **important** to get a good glue bond between the stab structure and the bottom stab skins. Apply a heavy bead of CA+ to all of the upward facing edges of one side of the stab structure. Place a skin on the structure and hold it in place with your hands until the glue sets. Repeat this for the other bottom skin. Be careful not to bend or twist the stab during this step.



24. True up the ends of the stab with a sanding block. Round the leading edge of the stab to match the cross section on the plan.



25. Glue on the 5/8" thick shaped balsa **Stab Tips**. Use a razor plane and a sanding block to airfoil them to match the stab. You may contour the tip to its final shape now, or wait until the model is nearer completion.



26. Cut away the skin in the area of the balance tabs. True up the skin with a T-bar.

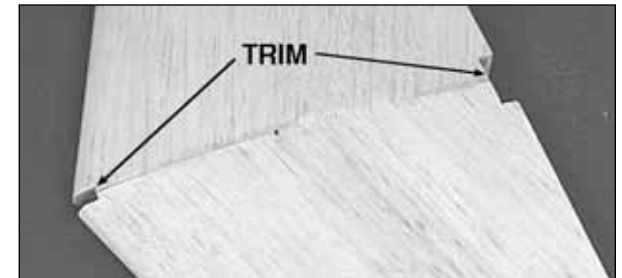

27. Cut away the skin at the center of the stab at the LE and TE as shown in the photo

BUILD THE FIN

1. Cut a 6-5/8" length of the tapered 1/4" balsa stabilizer LE stock. Notice that the fin LE protrudes through the stab.

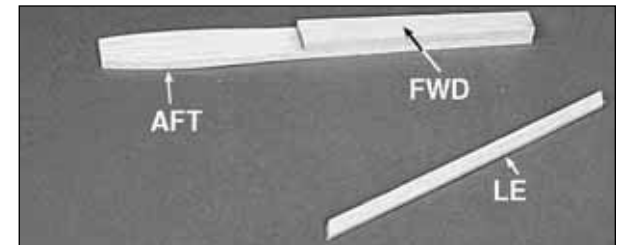

2. Glue the die-cut 3/16" balsa **Fwd** and **Aft Fin TE's** together with CA. Since these pieces are thick and die-cut, they will probably require a little touch up and blending with a sanding block.

3. Punch out the die-cut 3/32" balsa ribs **V-1** through **V-4**. Be sure to preserve their jig tabs.

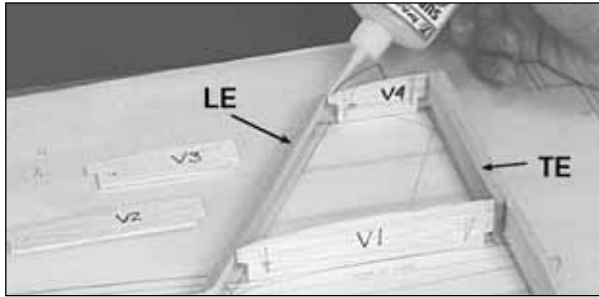

4. Pin ribs V-1 and V-4 to the building board over their proper locations. Center the LE vertically on the front of the ribs and glue it in place.

5. Center the Fin TE vertically on the aft edge of the ribs and glue it in place.



6. Put ribs V-2 and V-3 into their places and glue them. Remember, all jig tabs should contact the work surface.

7. Glue the die-cut 3/32" balsa **Fin Triangle** into the corner of V-4 and the Trailing Edge.

8. Apply extra CA+ glue to any joints that do not appear to be well glued.

9. Blend the LE to match the ribs on the upward facing (left) fin side. Sand the TE, if necessary, to blend smoothly with the ribs.

10. Make a skin for each side of the fin using the 1/16" balsa sheet left over from the stab skins. Make the skin so it overhangs past V-1 about 1/2"; this will allow fitting to the stab later. See the sketch on page 11.

11. With the structure flat on the table, glue on the left skin.



12. Trim off the jig tabs and blend the LE and TE to the ribs on the right side of the fin.

13. Glue on the right skin. Be sure to get a good bond between the ribs and the skin.

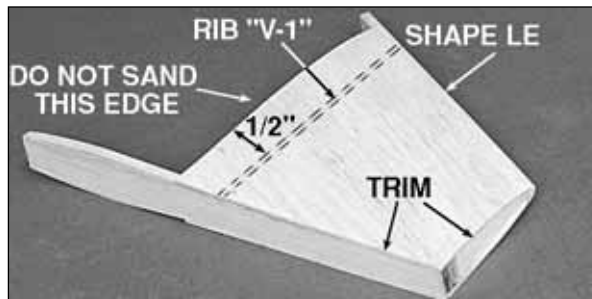

14. True up the edges of the fin sheeting with

a sanding block. Shape the LE to match the cross-section on the plans.



15. Glue the shaped 3/4" balsa **Fin Tip** to the top of the fin at the location shown on the plans. Use a razor plane and a sanding block to do the initial shaping of the tip. Final shaping should be done later, with the fin taped to the rudder.

BUILD THE ELEVATORS

NOTE: Build both elevators using the following steps:

1. Place the die-cut 3/32" balsa **Elevator Bases (EB)** on the plans and mark the "Rib" locations on both sides using the "tick" marks on the plans.

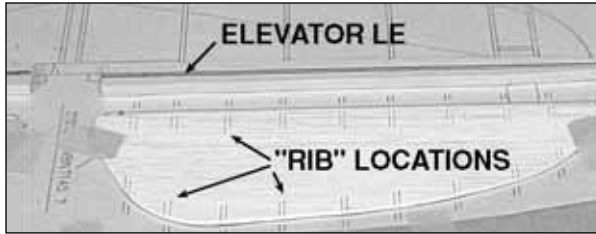

□ □ 2. Draw a centerline on both surfaces of the die-cut 1/4" balsa **Elevator LE (E)**. Draw two parallel lines 1/16" away from center line on the aft side.

□ □ 3. Hold the Elevator Base centered between the lines on the Elevator LE. Use CA to glue the Elevator Base to the LE.

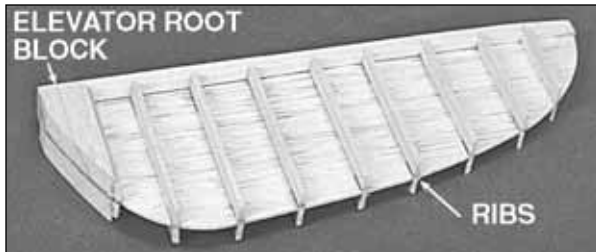

□ □ 4. Cut "**ribs**" from the 3/32" x 3/8" x 36" balsa sticks and glue them onto both sides of the elevator base at the locations you previously marked.

□ □ 5. Glue a 3/8" thick shaped balsa **Elevator Root block** to each side of the Elevator Base.

□ □ 6. Refer to the photos on this page and the cross-sections on the plans to obtain the shape of the elevators. Use a razor plane and sanding

block to "rough in" the shape of the elevators. Trial fit the elevators to the stab for final shaping.

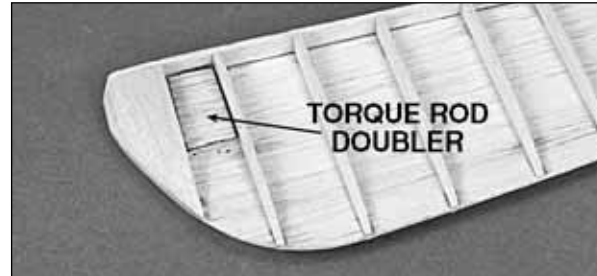

□ □ 7. Glue a die-cut 1/8" balsa elevator **Torque Rod Doubler** to both sides of the Elevator Base as shown on the plans.



□ □ 8. Cut a pocket in the bottom of the right elevator to match the 1/4" x 1/2" x 5/8" **Elevator Horn Block**. Check the plans for the proper location.

□ □ 9. Glue, using 6-minute epoxy, the birch plywood Elevator Horn Block in the pocket on the bottom side of the right elevator. Shape the Elevator Horn Block edge to match the elevator.



□ □ 10. Place the elevator over the plans and mark position of the 5/8" x 5/8" x 11/16" balsa **Counter Balance Block** on the elevator LE. Glue the Counter Balance Block in place. Shape the front of the block to a full radius. Allow approximately 1/16" clearance on both sides of the counter balance block in the stab opening.

□ □ 11. Shape the **Elevator LE** to a "V" shape to allow elevator travel. See the cross-section on the plans for the correct shape.

□ □ 12. Tape the elevators to the stabilizer. Hold the bent 1/8" **Elevator Joiner Wire** up to the elevator and mark the location of the holes (see the plans for the joiner location).

□ □ 13. Remove the elevators from the stabilizer. Drill 1/8" holes in the elevators for the Joiner wire. Make slots inboard of the holes to allow the wire to be inset into the elevators.

□ □ 14. Test fit the joiner wire into the elevators. Check to see if the elevators align with each other properly. Make adjustments if required.

BUILD THE RUDDER

□ 1. Glue the two die-cut 3/16" balsa **Rudder LE's** together with CA+. Even up the edges with a sanding block, but save any tapering for later.

2. Draw a centerline on the aft surface of the LE. Draw two parallel lines 1/16" away on both sides of the centerline.



3. Glue the die-cut 3/32" balsa **FWD Rudder Base** to the die-cut 3/32" balsa **AFT Rudder Base**.

4. Align the Rudder Base over the plans and mark the "Rib" locations on both sides of the Rudder Base.



5. Hold the Rudder Base centered on the rudder LE. Apply CA to the joint.

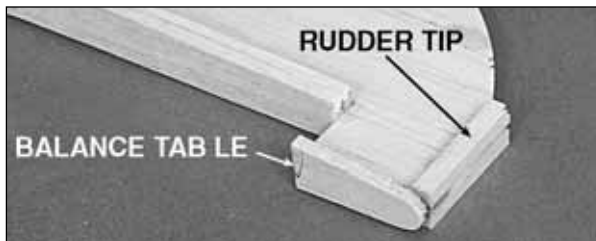

6. Center the 1/4" x 3/4" x 2" balsa rudder **Balance Tab LE** on the top of the rudder plate. Glue it with CA.

7. Glue a 1/4" x 1/4" x 1-3/4" stick balsa **Rudder Tip** to each side of the top of the rudder plate.

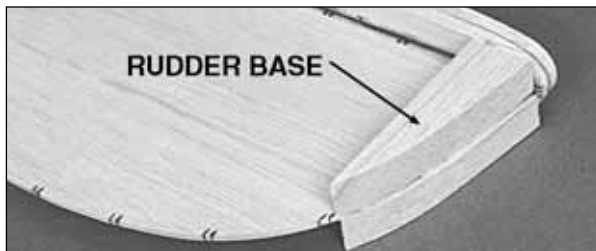

8. Glue a 1/2" thick shaped balsa **Rudder Base** to each side of the bottom of the rudder plate.



9. Cut "ribs" from the 3/32" x 1/2" x 36" balsa sticks and glue them onto both sides of the rudder at the locations you previously marked.

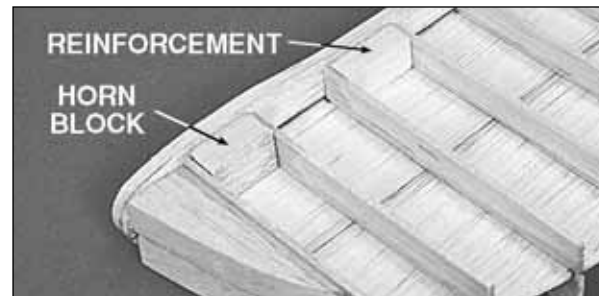

10. Glue the a 3/8" x 1/2" x 1-1/16" balsa **Rudder Reinforcement Stick** to each side of the rudder at the location shown on the plans. These will strengthen the rudder when the slot to clear the elevator joiner wire is cut out.

11. Glue the 1/2 x 5/8" x 15/16" hard balsa **Rudder Horn Block** to the left side of the rudder where it is shown on the plans.

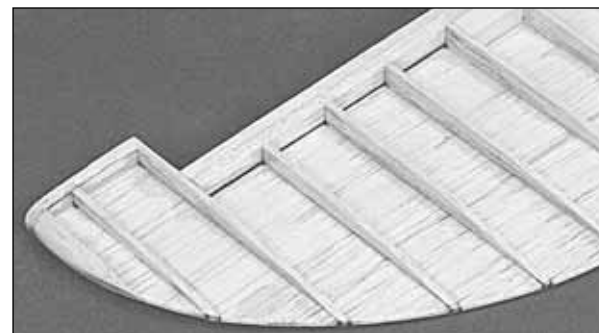

12. Refer to the photos and the cross-

sections on the plans to obtain the shape of the rudder. Use a razor plane and sanding block to “rough in” the shape of the rudder. Final shaping and fitting should be done after the fin is glued onto the fuselage, but you may wish to tape the rudder to the fin at this point to blend the upper ends of both.

BUILD THE WING

NOTE: The wing halves are built “**UPSIDE-DOWN**” on the plans. The jig tabs are attached to what is, in the end, the **TOP** surface of the wing.

NOTE: Since it is the standard convention to show the **Top View** of the wing, and the wing panels are built upside-down, the **LEFT** wing panel is built over the **RIGHT** Wing Top View and vice-versa. This does not present any problems; just be sure to build a left and a right wing panel.

❑ 1. Place the wing plan on your building board and cover it with waxed paper (you may wish to cut apart the wing panel sections of the plan to make handling easier.)

❑ 2. Hold the four 1/4” x 3/8” x 36” hard balsa **Spars** over the wing plans. Mark the spars about 1/4” longer than they need to be. Cut off the spars at the marks and save the scraps for the flap and aileron servo mounts.

❑ 3. Punch out all the die-cut 3/32” balsa wing **Ribs**. Smooth out any imperfections with sandpaper. Be sure to keep the jig tabs attached to the ribs.

❑ 4. Ribs W-1 through W-8 have punch marks just aft of the spar that locate the aileron pushrods for you. Drill a 3/16” hole at each of these marks.

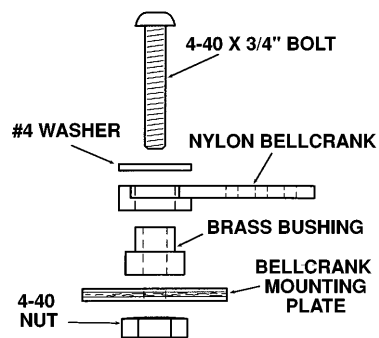
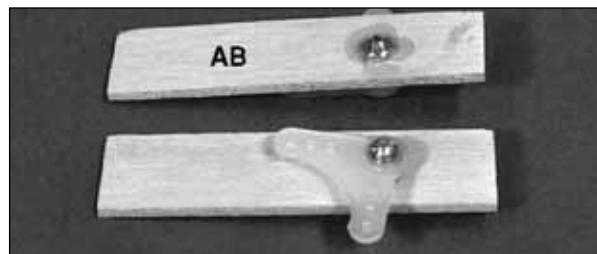

❑ 5. Drill 1/8” holes through the punch marks in the two die-cut 1/8” plywood **Aileron Bellcrank Plates (AB)**. Assemble the bellcrank parts as shown in the sketch. **Be sure to put a drop of 6-minute epoxy on the 4-40 nut and threads to prevent the bellcrank from vibrating loose.**



❑ 6. Taper one end of each of the four 1/8” x 3/8” x 17-1/2” balsa **Spar Doublers** to match the spar detail drawing on the plans. Glue a Spar Doubler to each Spar with the root (non-tapered) end of the doubler aligned with the root end of the spar.

NOTE: The top edge of the **FWD TRAILING EDGE AT AILERON** curves more than the bottom edge at the tip. Since the wing is being built upside down, the more curved edge faces down next to the plans.



❑ 7. Center the die-cut 1/4” balsa **Aft Trailing Edge at Aileron (A)** on the die-cut 1/4” balsa **Forward Trailing Edge at Aileron (F)** and glue them together with CA. Be **sure** to make a **left** and a **right** trailing edge. Use a sanding block to taper the two pieces slightly as shown in the cross-sectional drawing on the plan. These pieces are die-cut slightly long to allow you to trim off any imperfections.

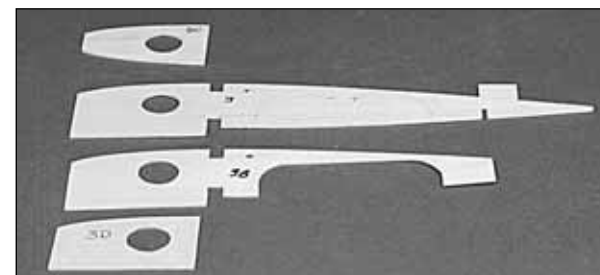

❑ 8. Each of the W-4 and W-3 ribs is made up of four laminations. Refer to the plans for the proper

order of the parts (e.g. 4C, 4, 4B, 4D.) Use CA+ to glue the parts together. Be **sure** to make a **left** and a **right** of each rib assembly.

☐ 9. Enlarge the pushrod hole in each W-8 until it is a 5/16" x 5/16" square hole. This will provide clearance for the clevis.

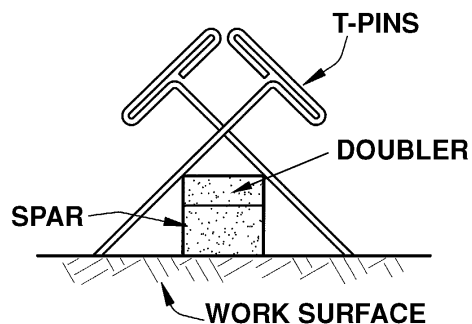

☐ 10. Pin a **Spar** assembly to the building board at three or four locations using the cross-pinning technique shown in the sketch.



☐ 11. Glue the die-cut 3/32" balsa ribs **W-2** through **W-12** to the spar. These should be vertical and aligned over their appropriate locations as indicated on the plans. The jig tabs located near the aft end of the ribs should all contact the work surface.



☐ 12. Glue the aileron trailing edge assembly to the aft edge of ribs W-8 through W-12. The upward facing edges of the ribs and the top surface of the trailing edge should be even, and all of the jig tabs should touch the work surface. **NOTE:** The inboard end of the aileron TE extends approximately 5/8" inboard of rib W-8, as shown on the plan.

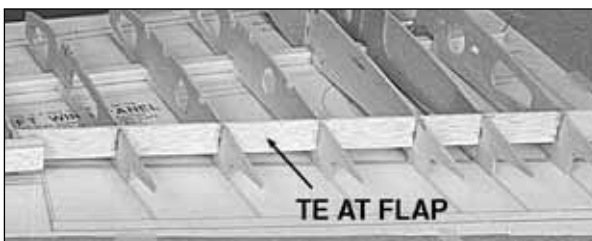

☐ 13. Test fit the die-cut 1/8" balsa **TE At Flap** to the wing ribs. You will probably have to angle the notches with your hobby knife to match the forward sweep of the trailing edge. Place the TE At Flap back into the wing rib structure but do not glue yet.

☐ 14. Sight down the TE of the wing from the root end; make sure all the ribs are aligned at the same height. Use paper to shim under the jig tabs of any ribs that are low. This will put the TE's of the ribs in line.

☐ 15. When the TE At Flap is fitting in place well, with all of the rib TE's aligned, glue it in with CA+.

NOTE: Do steps 16 and 17 for a plane without operating flaps. Skip these steps for a plane with operational flaps.

☐ 16. Cut the ends of the tapered 1/2" x 19" balsa **Flap TE** about 1/8" longer than it is shown on the plan. **Note:** This Flap TE is not used if you build operating flaps.

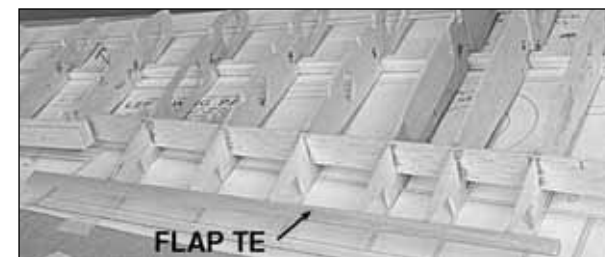

☐ 17. Glue the **Flap TE** to ribs W-2 and W-7. The Flap TE should be centered vertically on the aft edges of the ribs and should be symmetrically aligned with the top and bottom of the ribs. Make sure all the jig tabs are contacting the work surface. A metal straightedge can be placed on the structure over the jig tabs to hold them down evenly.

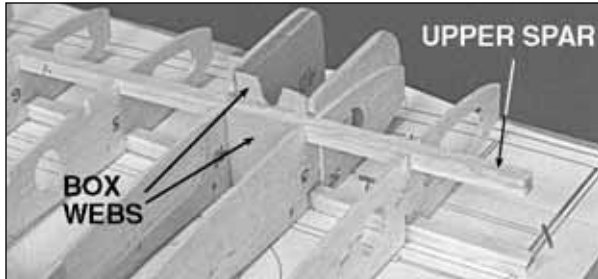

18. Work the **Upper Spar** assembly into place, making sure it fits well. Put some weights on top of the structure to make sure it is held onto the work surface. Fit the die-cut 1/16" plywood **Fwd** and **Aft LG Box Webs** between W-3 and W-4 to confirm the angle of these ribs. Use CA to glue in the top spar. Thoroughly glue the Fwd and Aft LG Box Webs to the spars as well as W-3 and W-4.

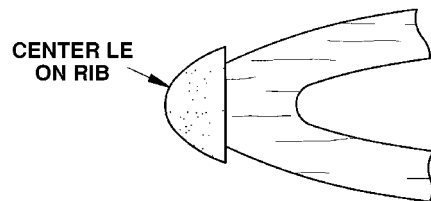
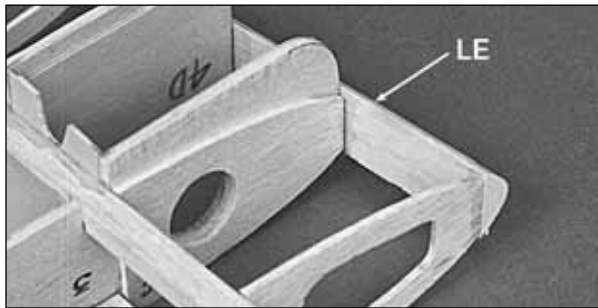

19. Hold the shaped balsa **Leading Edge** centered vertically on the front edge of the ribs. Use CA to glue it in place.

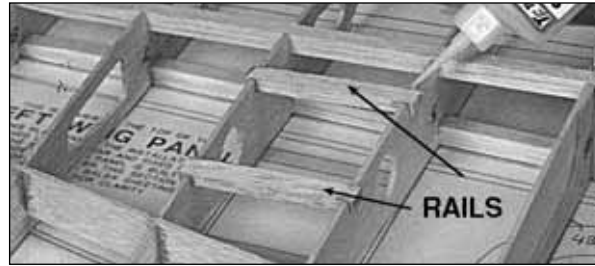

20. If you are going to use flaps, trim the 1/4" x 3/8" balsa stock left over from the wing spars to the length shown on the plans for the **Flap Bay Rails**. Glue the rails into the notches in W-5 and W-6 with CA. If you do not plan to use flaps, you should fill the notches with scrap wood.

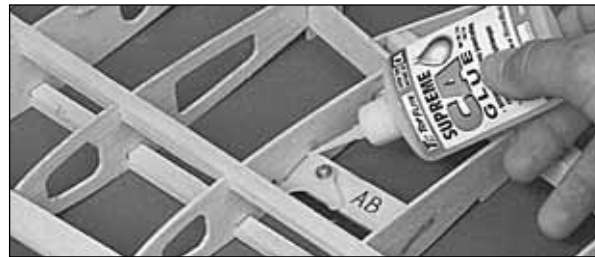

21. Glue the aileron bellcrank assembly into the slots in ribs W-8 and W-9. The bellcrank should face away from the building board as shown in the photo.



22. Glue the die-cut 1/8" balsa **Corner**

Brace into the corner of W-8 and the Trailing Edge.

Note: Do steps 23 and 24 for a plane without operating flaps. Skip them for a plane with operating flaps.



23. Test fit, then glue in the die-cut 3/32" balsa **Flap Tip Rib** at the location shown on the plans.



24. Glue in the die-cut 3/32" balsa **Flap Root Rib**.



☐ ☐ 25. Trim the 1/16" balsa **Shear Webs** to fit behind the spar between ribs W-4 through W-12. Glue them in place with CA+. Wick CA- into all the joints of the Shear Webs and the Spars to make sure they are well bonded. It is not important to glue the shear webs to the ribs.

☐ ☐ 26. Cut a 13" length of **Outer Pushrod Tube**. Rough up the outside of the tube with 220 grit sandpaper. Feed the tube through the holes in the ribs as shown on the plans. Use CA to glue the tube in place.

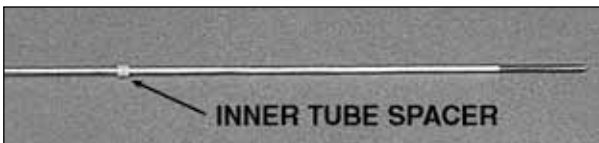

☐ ☐ 27. Cut three lengths of **Inner Pushrod Tube** about 5/16" long and slide them onto a .074" x 36" threaded one end wire, at the intervals shown on the plans. Carefully apply a small drop of CA to secure each short tube if they are not very snug on the wire.

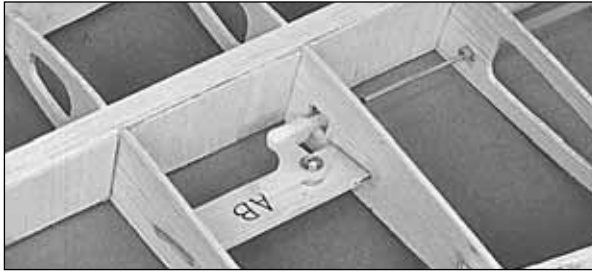

☐ ☐ 28. Snap a **Nylon Clevis with Clevis Retainer** securely onto the bellcrank. Feed the wire assembly into the wing and screw the threaded end well into the clevis. **Hint:** The wire is extra long. After the threaded end starts threading into the clevis, you may bend over the excess wire and use it as a handle to turn the wire the rest of the way into the clevis. Be sure to hold the clevis securely with pliers while threading the wire into it to keep from stressing the clevis pin. Cut off the excess wire about 1-1/4" beyond the root end of the spar.



INSTALL THE CENTER RIB (W-1)

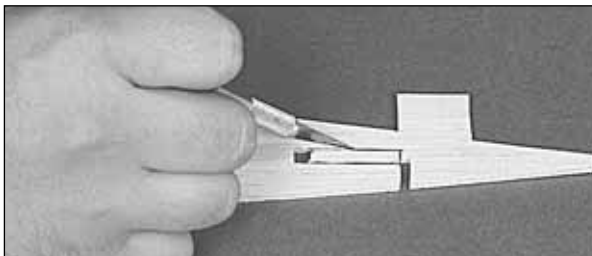

☐ ☐ 29. Finish cutting the slot in the aft part of the two **W-1** ribs for the **Wing Bolt Plate**.

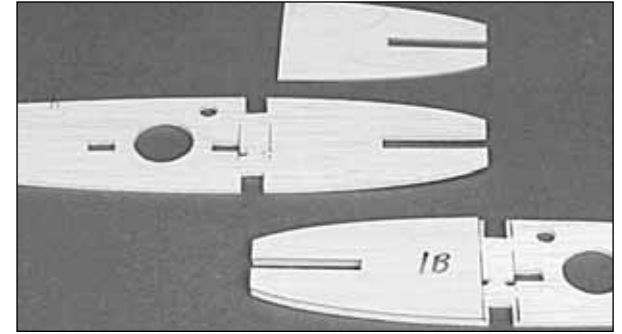

☐ ☐ 30. Glue the die-cut 1/16" ply **W-1B** doubler ribs to the W-1's. Be **sure** to make a left and a right.



☐ ☐ 31. Glue the die-cut 1/8" balsa **Fwd Center Brace (FCB)** to rib W-2 over its location on the plans.

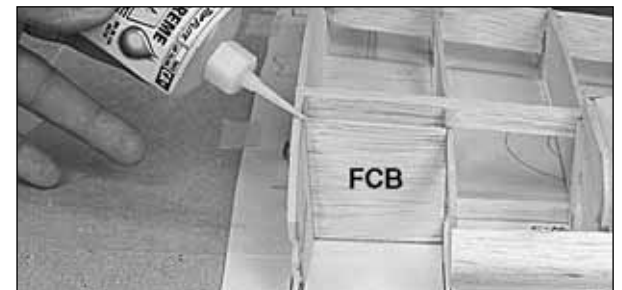

☐ ☐ 32. Place rib W-1 into position. Glue it in place with CA+. **NOTE:** FCB sets W-1 at the correct angle.



33. Glue the $\frac{3}{8}$ " x $1\text{-}\frac{3}{16}$ " x $2\text{-}\frac{1}{2}$ " balsa **Center LE Block** to the front of W-1 and the LE. Cut a **V-notch** in the Center LE Block centered on the dowel notch in W-1. This notch will assist you in drilling for the dowel later.

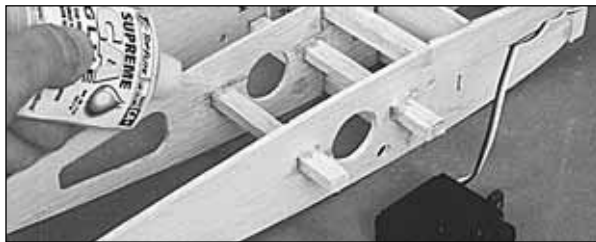

34. Insert the $\frac{1}{4}$ " x $\frac{3}{8}$ " balsa **Servo Mount Rails** (left over from the wing spars) into the slots in W-1 and W-2. Adjust the aft rail's position to allow the servo you will use to fit comfortably. Glue the rails in place.



35. Trim the spars, the servo mounts, and the LE Block flush with W-1.

INSTALL THE CENTER TE BLOCK

Do steps 1 and 2 if you are **NOT** building operating flaps.

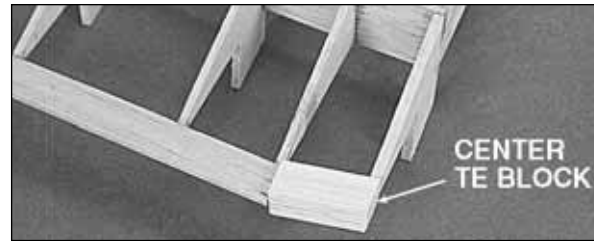

1. Glue the $\frac{3}{8}$ " x $\frac{1}{2}$ " x $1\text{-}\frac{1}{4}$ " **Center TE Block** to the TE of rib W-1 and the Flap TE.
2. Trim off the end of the Center TE Block flush with W-1. The block should be shaped after the wing is joined and sheeted.

PREPARE THE WING PANELS FOR THE FLAPS

Do steps 1 through 14 if you are building operating flaps.



1. Remove the wing panel from the building board. Use a T-bar with fresh 220 grit sandpaper to blend away any unevenness from the structure. Pay special attention to the trailing edge of the wing. It is important to make the trailing edge as straight as possible so the split flaps will fit well.

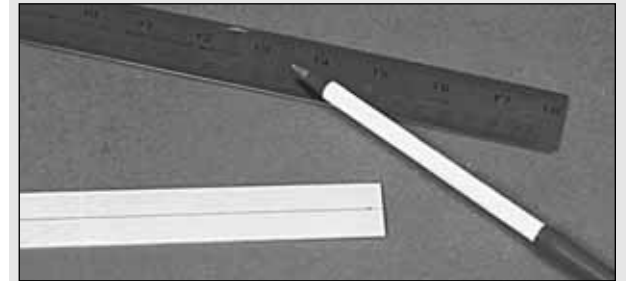

2. Draw a centerline down the $\frac{1}{16}$ " x 1" x 19" plywood **TE Strip**.

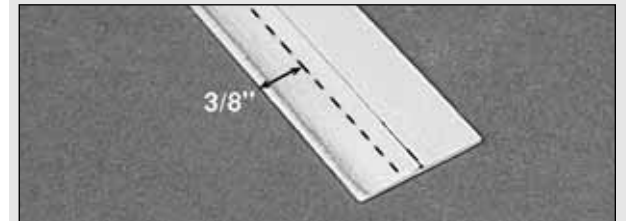

3. Use a T-bar with sharp 150 or 220 grit paper to bevel the aft $\frac{3}{8}$ " of the TE Strip. This will allow the TE to be only $\frac{3}{32}$ " thick when the flaps are shut. See the cross-section on the plans for the correct thickness and angle.

4. Locate the two $\frac{3}{32}$ " x $\frac{5}{8}$ " x 18" balsa **TE Jig Strips**. Check the straightness of these jigs by holding them up on edge on a flat table. True them up with a knife and a metal straight edge if required.

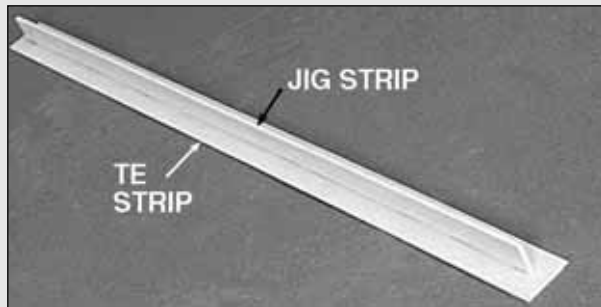

□ □ 5. Place the TE Strip with the beveled and centerline-marked side down on a very flat table. Glue a TE Jig Strip to the TE Strip. The jig strip will keep the TE straight until the wing is complete. Do **not** use excessive glue because it will have to be sanded off later.



□ □ 6. Glue the TE assembly to the wing structure. The aft end of ribs W-2 through W-7 should align with the centerline you drew on the TE Strip. Do not force the ribs to touch the TE Strip. This will cause the TE to warp when you remove the Jig later; just fill any slight gaps with glue.

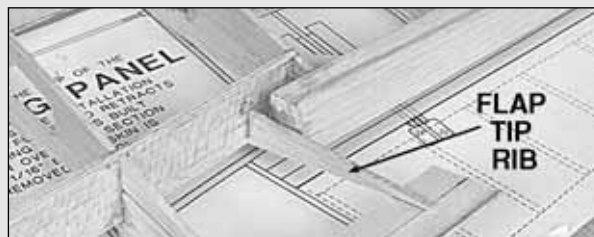
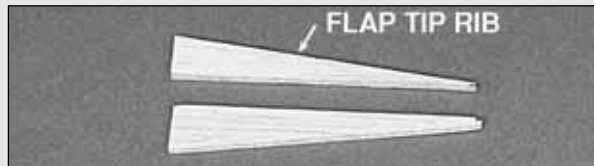

□ □ 7. Cut the die-cut 3/32" balsa **Flap Tip Rib** in half along its centerline. Align half of the rib over the plans and glue it in as shown in the photo.

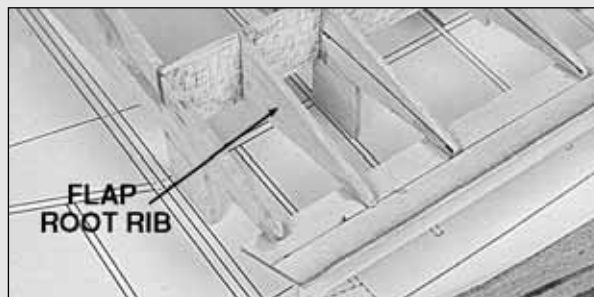

□ □ 8. Align the die-cut 3/32" balsa **Flap Root Rib** over its location on the plan and glue it in with CA+.



□ □ 9. Trim off the ends of the TE Strip flush



with the W-1 rib and the Flap Tip Rib.

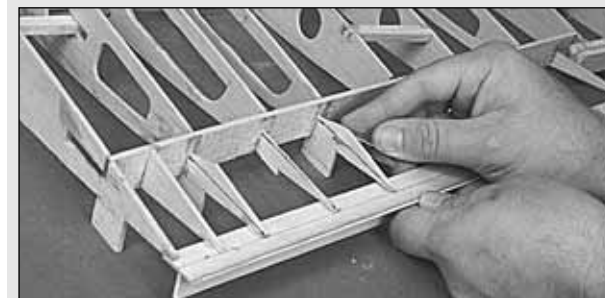

□ □ 10. Use a razor saw and a single edge razor blade to trim off the **bottom** half of ribs W-2 to W-7 (behind the TE at Flap). The **bottom** side is the side opposite the jig tabs.



□ □ 11. Use a T-bar sander to even up the ribs inside the flap bay.

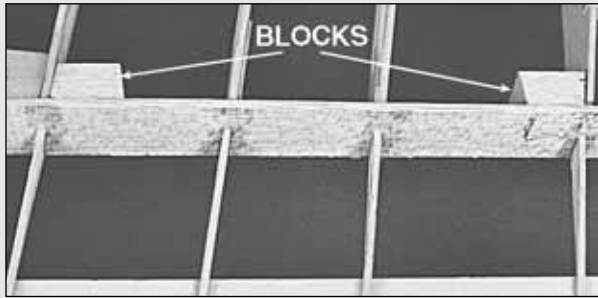

12. Cut the 5/8" X 5/8" X 6" balsa stick into six equal blocks. Fit and glue these Flap Hinge Blocks in place where shown on the wing plan.

13. Mark the locations of the hinge blocks on the TE to help you find them later.

14. Decide how you want to route the flap servo extension wires. You will need to go through or around the wheel well. Add passageways for the extension in W-3 and W-4 if needed.

NOTE: Actual flap construction will begin on page 27.

Repeat the previous wing sections (starting on page 16) to build the other wing panel. Use the other half of the wing plan, and remember to build a right and a left wing panel.

JOIN THE WING PANELS

1. Trim the ends of the spars and LE's of both panels even with rib W-12. Excess overhang will affect the dihedral angle.



2. Cut away the portion of rib W-1 around the spars as shown in the photo. This will allow the dihedral braces to pass through.

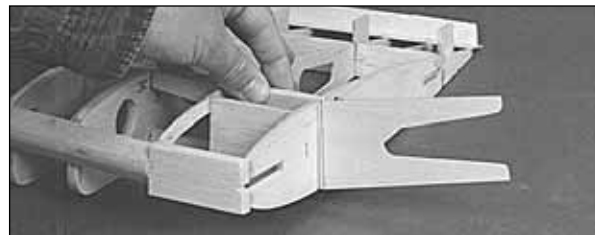

3. Test fit the die-cut 1/16" plywood **Dihedral Braces** into each wing half. Make sure the Brace centerline can go all the way to the wing centerline. Trim the ends of the Braces slightly, if required.

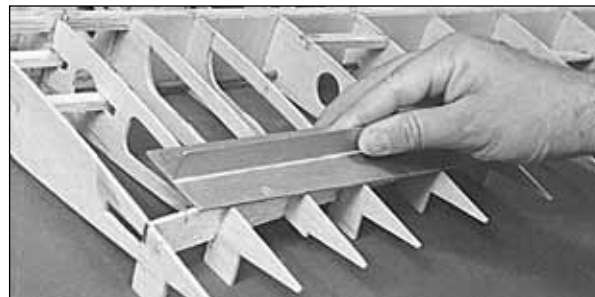

4. Trim the jig tabs off all of the wing ribs **except W-1 and W-12**. Use a T-bar to blend the airfoil where the jig tabs were removed.



5. Drill two 1/4" holes in the shaped 1/4" plywood **Wing Bolt Plate** at the locations shown on the wing plan.

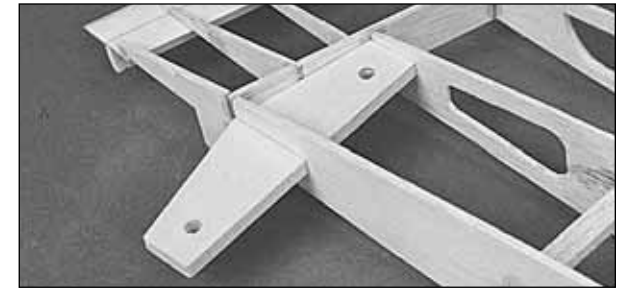

6. Test fit the 1/4" plywood **Wing Bolt Plate** into each wing panel. Make adjustments, if necessary, until the Wing Bolt Plate fits well.

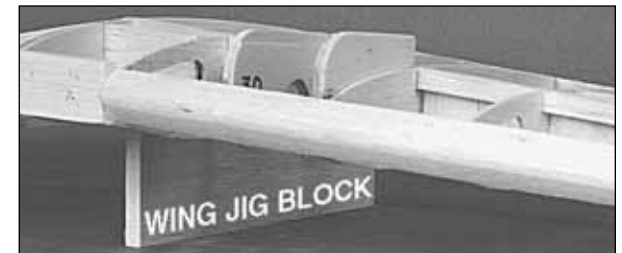

7. Assemble the two wing halves, the two **Dihedral Braces**, and the **Wing Bolt Plate** together.

Place the 3/8" x 2-5/8" x 10" balsa **Wing Jig Block** under W-1. The W-1 jig tabs and the spar at W-1 should contact the Wing Jig Block. The W-12 jig tabs and the spar at W-12 should contact your flat work table.



□ 8. When you have confirmed that all of the parts fit well, disassemble the wing parts. Coat the inside of the Dihedral braces and the area of the Spars that they contact with a thin film of 30-minute epoxy. Reassemble the wing parts onto the jig block. Align the two W-1 ribs with each other and glue them together with CA. Make sure the wing is properly jugged. Clamp the Dihedral braces to the Spars with clamps or masking tape.

□ 9. Apply a fillet of 30-minute epoxy around the Wing Bolt Plate.

□ 10. Use 30-minute epoxy to fill any gaps where the Spars join in the middle.

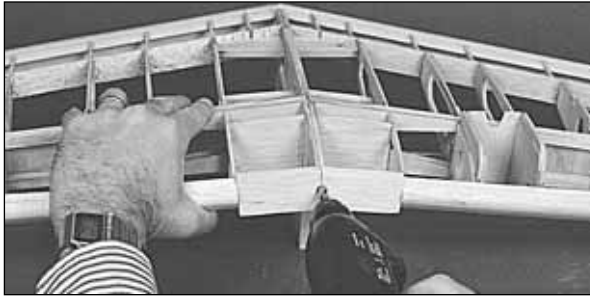

□ 11. Drill a 3/16" pilot hole through the wing LE for the 5/16" **Wing Dowel**. Gradually enlarge the hole to 5/16" keeping the drill centered on the two W-1 ribs.



□ 12. Make a 1/16" balsa shear web to fit between W-2 and W-3. Glue it to the Dihedral Brace on the aft side of the spar.



□ 13. Make the aileron pushrods from the 4" threaded end rod. Use a **Nylon Clevis** with a Clevis Retainer on the horn end and a Z-bend on the Bellcrank end. Make them the length shown on the wing plan top view.

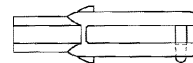

□ 14. Drill out the outer hole in the bellcranks with a 5/64" drill bit. Test fit the pushrod into the bellcrank.

FIXED LANDING GEAR ASSEMBLY

Do the following six steps to make a left and a right fixed gear assembly.

NOTE: The fixed gear is slightly shorter than scale to improve ground handling.

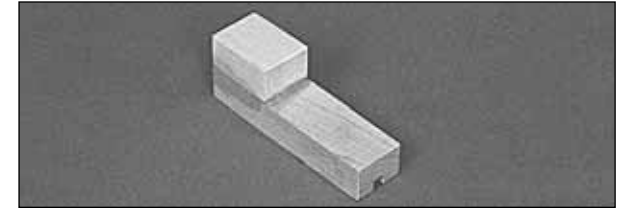

□ □ 1. Use 30-minute epoxy to glue the 3/4" x 5/8" x 1" hardwood **Landing Gear Block** to one end of the slotted 1/2" x 3/4" x 2-3/4" hardwood **Landing Gear Rail** as shown on the plan and in the photo.

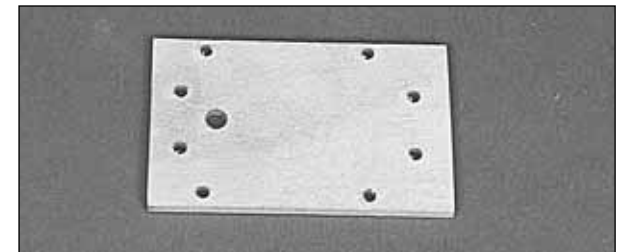

□ □ 2. Locate the 1/8" x 1-11/16" x 2-3/4" birch plywood **Landing Gear Plate**. Use the template provided on the wing plan to mark the hole locations. Drill the holes to the sizes indicated on the template.

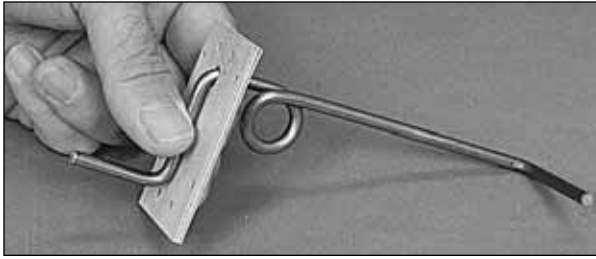

- 3. Test fit the bent **Landing Gear** wire through the Landing Gear Plate. Chamfer the hole in the plate for the wire, if required, until the wire will lie fairly flat on the plate.

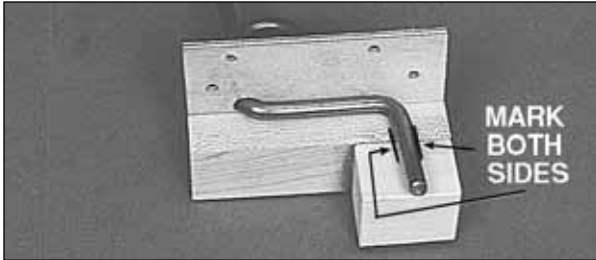

- 4. Hold the Landing Gear Rail assembly up to the Landing Gear Plate and wire. Mark the location where the wire will insert into the Landing Gear Rail.

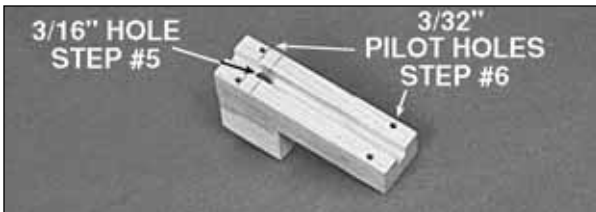

- 5. Drill the Landing Gear Rail assembly with a 3/16" drill. Test fit the parts together and chamfer the hole entries as required for a good fit. **Note:** Small gaps will be pulled together when the parts are screwed together.

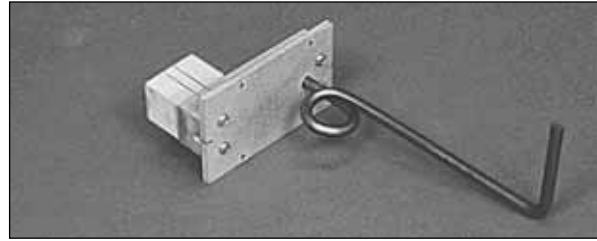

- 6. Mark the locations for the #4 screws. Drill 3/32" pilot holes at the locations you marked. Screw the parts together with #4 x 1/2" **Sheet Metal Screws**.

MOUNT THE LANDING GEAR

Do the following eight steps for Retract and Fixed Gear.

If you are using fixed gear, just substitute the fixed gear assemblies for the retracts. They mount the same way.

NOTE: By mounting the retracts to the rails first, then gluing the rails into the structure, the retract frames will be relaxed. If you glue the rails in by themselves, the frame is likely to be bent when you tighten the mounting screws; this will cause the retracts to bind.



- 1. Fit the 1/4 x 5/16" x 3-1/8" **Landing Gear Rails** and the retracts between ribs W-3 and W-4 as shown in the picture. Mark the locations of the retract (or fixed gear) mounting screws.

- 2. Remove the Rails and drill the locations you marked with a 7/64" bit.

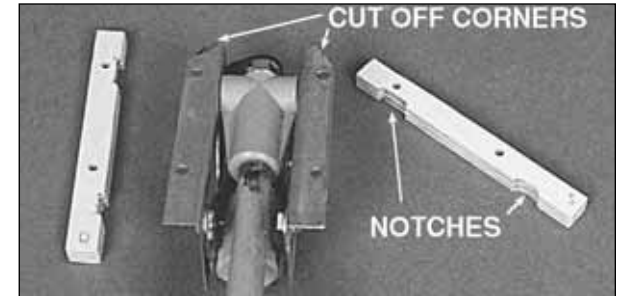

- 3. Mark the locations of any notches you need to make in the rails to facilitate retract removal. Make these notches with a Dremel® Moto-Tool®.

NOTICE how the front corners of the retract mounting lugs have been cut off at an angle. This provides more clearance for the landing gear pods. The corners may be cut off using a cutoff wheel. Be sure to use safety glasses when using a cutoff wheel.

- 4. Mount the retracts (or fixed gear assemblies) to the rails with #6 x 1/2" sheet metal screws.



- 5. Test fit both retracts with rails into the wing structure. View the struts from all angles to check

their alignment. View the struts from the front of the wing. The two struts should be parallel and therefore perpendicular to the ground. Make slight adjustments to the rails or structure until the landing gear fits well.

❑ 6. Glue in the retract rails with a generous amount of 30-minute epoxy. Be careful not to glue in the retracts (or fixed gear).

❑ 7. After the glue has cured, remove the landing gear and apply a fillet of 30-minute epoxy to all of the plywood joints in the landing gear box area.

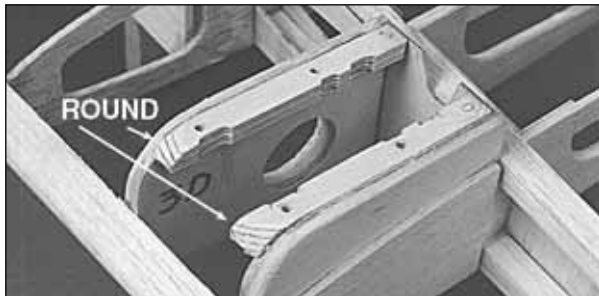

❑ 8. Round the front edges of the Landing Gear Rails as shown in the photo. This will provide clearance for the Landing Gear Pods.

SHEET THE BOTTOM OF WING

❑ 1. Sort through the remaining 1/16" x 3" x 30" wing sheeting. Pick out the best 8 sheets and set them aside for the top of the wing.

NOTE: The wing sheeting process described here has you sheet the wing

from the spar forward with one skin (2 skins for the bottom because of the landing gear bay). You will then sheet the wing from the spar back with another skin. This technique is a good compromise between sheeting the wing with individual sheets, and making one complete skin for the entire wing panel. It allows you to presand all of the seams that are over open structure and it is easier to align and glue than a complete one-piece skin.

NOTE: All balsa sheeting will usually bend when it is cut from the log since stresses are relieved. For best results, trim the edges of the wing sheeting with a long metal straight edge and a sharp knife before joining them.

❑ 2. Lay waxed paper over a flat smooth work surface. You will join the wing skins on this surface.

NOTE: Do the following steps for both the right and left wing halves.

NOTE: The bottom of the wing must be sheeted with the wing on the jig tabs and the Wing Jig Block to avoid twists.

❑ 3. Edge glue two 1/16" x 3" x 30" balsa wing sheets together with CA for both the top and bottom wing surfaces. **Hint:** A quick wipe of a paper towel while gluing the sheets will soak up most of the excess CA and make sanding the seams easier.

NOTE: The steps below show the sheeting of a wing with functioning

flaps. The wing without functioning flaps is done the same way, but it will look slightly different. When sheeting a wing without functioning flaps, make the skin aft of the spar so it covers the structure all the way back to the Flap TE.

❑ 4. LIGHTLY sand both sides of the skin over the work surface with a sanding block and sharp 220 sandpaper.

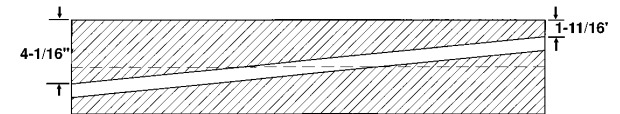

❑ 5. Mark the skin as shown in the sketch above. Cut the sheet in half diagonally and use the pieces for the bottom forward portions of the wing.



❑ 6. Cut off a piece of the sheet you made in the above step large enough to sheet the area inboard of W-3. Glue the sheet in place. The aft edge of the sheeting should extend back to the approximate centerline of the spar.



7. Use the leftover sheet from the previous step to sheet the forward portion of the wing outboard of W-4.

8. Edge glue three (or four for fixed flaps) 1/16" x 3" x 30" balsa wing sheets together and sand the seams. Tape the sheet to the bottom surface of the wing along the edge created by the forward sheeting. Mark the perimeter of the sheet from the inside with a pen. Cut the sheet down close to the correct size.

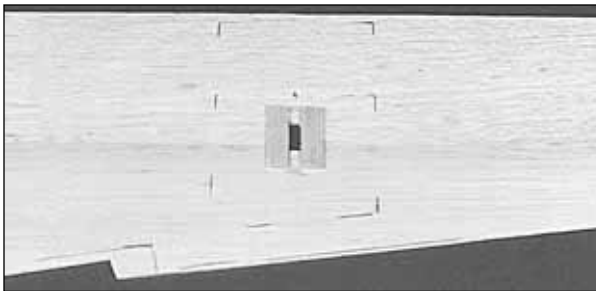

9. Use the plans to help you locate the aileron pushrod exit. Cut out an opening and reinforce the skin from the inside with two small strips of 1/16" scrap balsa.

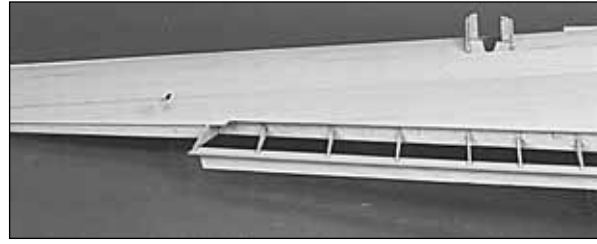

10. Tape the skin to the bottom of the wing structure so it is aligned along the spar. Make sure it fits well, especially at the root rib (W-1). Remove the skin from the structure.

11. Apply a bead of CA+ to all of the structure the skin will touch.



12. Attach the aileron pushrod to the bellcrank and position the skin onto the structure. Gently press the wing skin down onto the wing structure.

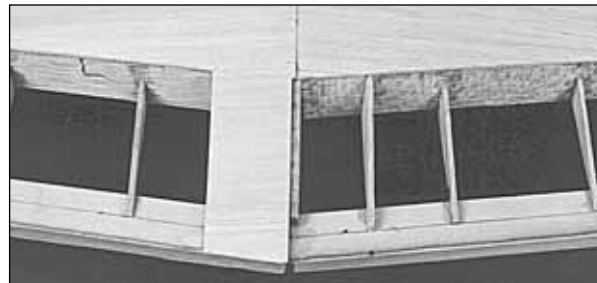

13. Sheet any remaining openings in the bottom wing skin such as the Trailing Edge between the flaps (for the operating flap option).

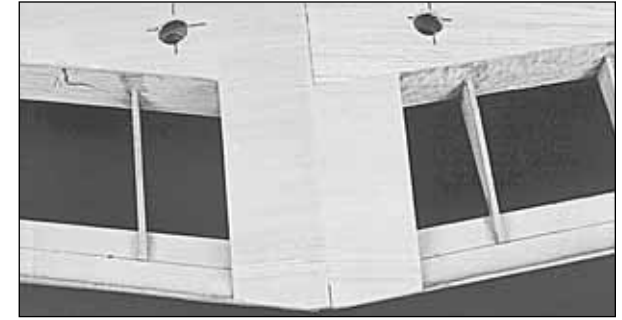

14. Use a punch to mark the hole locations in the bottom wing skin for the wing bolts. Start these holes so you can find the location later, after the top wing skin is applied.

SHEET THE TOP OF THE WING

***NOTE:** This kit includes a special wing jig to hold the wing at the proper washout angle while you apply the final wing skin. Twisted wings are a major cause of bad flight characteristics. Dihedral angles can vary slightly; so if your tip jigs require adjustment, just be sure that both tip jigs are modified the same, and are therefore identical. Be careful not to change the washout angle (the angle of attack of the tip ribs) if you adjust the jigs.*

1. Make the skins for the top of the wing forward of the spar using the same method that you used on the bottom of the wing (Page 24, Step 6.)

2. Trim the remaining jig tabs of W-1 and W-12. Blend any inconsistencies in the top wing surface away with a T-bar and 220 grit paper.

3. Temporarily place the 5/16 x 3-1/8" **Wing Dowel** into the hole you drilled into the LE (do not glue it yet).

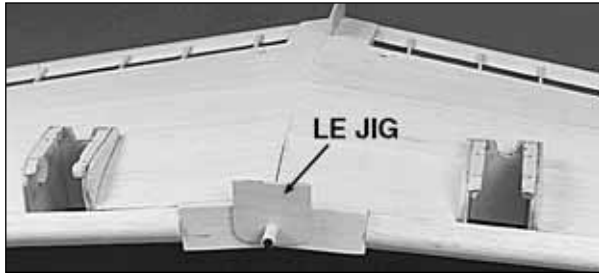

- 4. Slide the die-cut 1/8" Plywood **LE Jig** over the dowel.



- 5. Tack glue the die-cut 1/8" Plywood **TE Jig** to the bottom of the wing at the center as shown in the photo.



- 6. Place a die-cut 1/8" plywood **Tip Jig** under each W-12 rib. You may tape or tack glue the wing to the jig if you wish.

- 7. Check the fit of the forward skin to the wing structure. Make adjustments if required.

- 8. Apply a bead of CA+ to the wing structure and glue the forward wing skin in position.

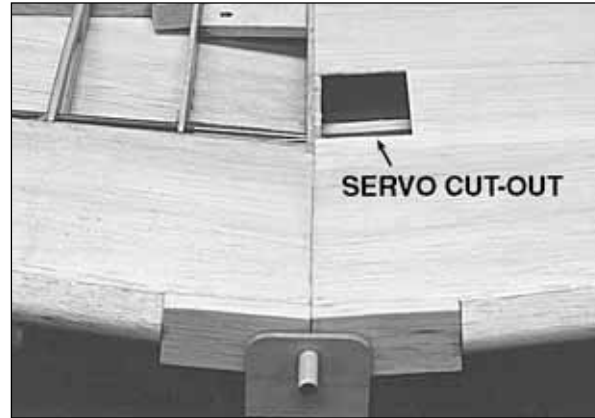

- 9. Make a skin for the aft portion of the wing from four 1/16" x 3" x 30" balsa sheets. Trim it to fit over the remaining open structure. Make a skin for the other panel and trace the first wing skin shape onto it.

***HINT:** You may find it easier to start cutting out the opening for the Aileron and Drop tank (optional) servos at the center of the wing when only one top aft skin is glued on.*

- 10. Apply a bead of CA+ to the wing structure and glue the aft wing skin in position. Glue both right and left sheets in place.

- 11. At this point, you should have the main wing structure fully sheeted. You may now remove the wing from the jig.

- 12. Add a bead of CA+ to the center joint to add more strength at this critical area.

- 13. Cut adequate clearance holes for the wing bolts in the top wing skin.

WING COMPLETION

- 1. Trim the sheeting where it protrudes past the edge of the structure. It is preferred that you trim the tip of the wing sheeting to the **center** of rib W-12. This will allow you to sheet the section between W-12 and W-13 more easily.

- 2. Razor plane and sand the wing Leading Edge until it blends into the airfoil well. Final sanding near the tip should be done later, after the tip is installed.

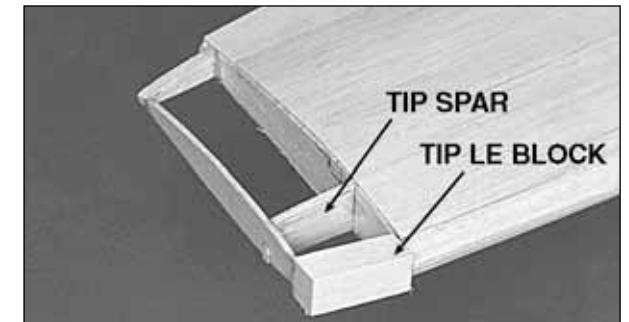

- 3. Glue the die-cut 1/8" balsa **Tip Spar** and the die-cut 3/32" balsa rib **W-13** to the tip of the wing as shown in the photo.

- 4. Glue the shaped 3/4" balsa **Tip LE Block** to the front of the wing.

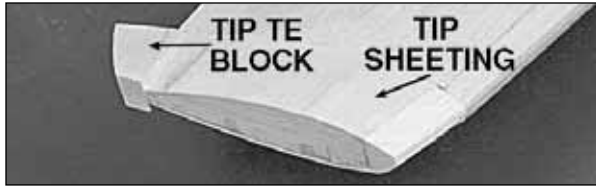

- 5. Apply 1/16" balsa sheeting to the tip section.
- 6. Glue the shaped 5/8" balsa **TIP TE Block** to the aft part of the wing tip.
- 7. Square off the tip of the wing with a T-bar.
- 8. Glue the shaped 1" balsa **Wing Tip** to the tip of the wing as shown on the plans.



- 9. Shape the tip of the wing with a razor plane and a sanding block. Do not final shape the aft portion of the tip until after the ailerons are built. This will allow you to properly blend them together.

BUILD THE FLAPS

- 1. Place the **Flap** section of the plans on a flat work surface and cover it with waxed paper.
- 2. Position a 1/16" x 3" x 30" balsa sheet over the proper location on the plan. Mark the length and width on the balsa sheet.

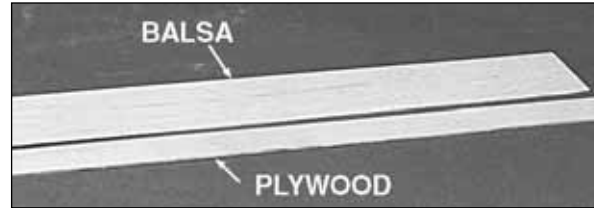

- 3. Cut the **Aft Flap Section** from 1/16" x 1" x 18-1/2" plywood. Match the Aft section edge to the balsa forward section edge. Sand the edges for a clean match.
- 4. Glue the sections together and mark the final size from the plans. Cut the flap sheet down to the proper size.

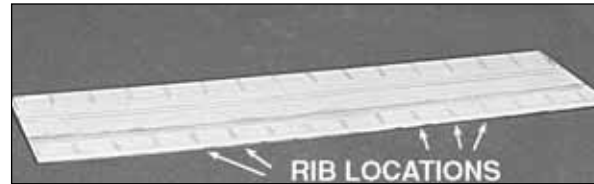

- 5. Mark the "**Rib and Spar Locations**" on the sheeting from the plans. **NOTE:** The ribs do not extend to the aft edge of the plywood.

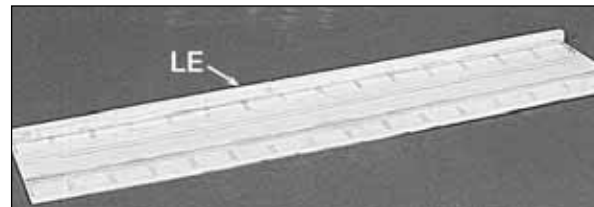

- 6. Cut the **Flap LE** from the 3/16" x 5/16" x 36" balsa stick. Place the LE and sheeting over the plans to check proper length and angles. Glue the LE on top of the sheeting aligned with the forward edge.

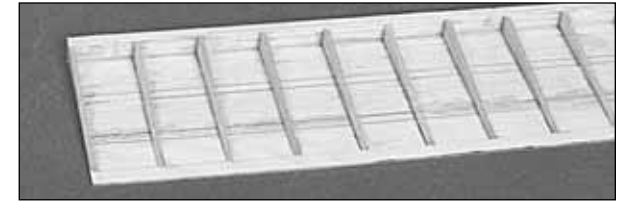

- 7. Cut 2-3/4" flap ribs from the 3/32" x 3/8" x 30" balsa **sticks**. Glue the Ribs to the sheeting at the locations you marked earlier. **NOTE:** The Ribs may be angle cut before gluing or sanded to shape after gluing.

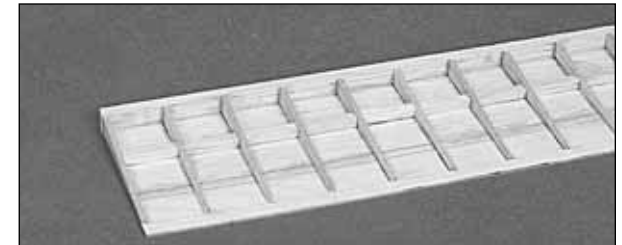

- 8. Fit and glue the **Fwd Flap Stringers**. They are pre-cut 3/16" x 3/16" x 15/16" balsa sticks.

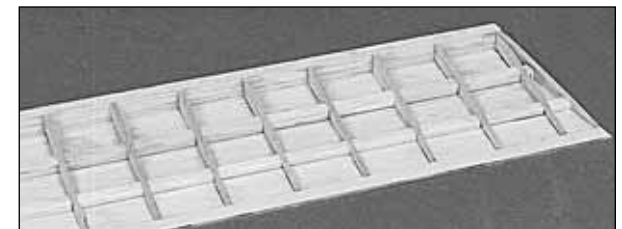

- 9. Fit and glue the **Aft Flap Stringers**. They are pre-cut 1/8" x 3/16" x 15/16" balsa sticks.

- 10. Use a sanding block to shape the ribs. The sanded surface of the ribs and all stringer surfaces will be flat when shaping is complete.

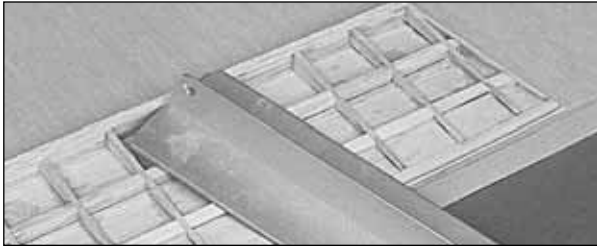

11. Place the TE on the edge of the work surface. Use a sanding block to feather the edge of the birch TE to approximately 1/32" thick. **HINT:** The TE will change color from light to dark to light when properly sanded.

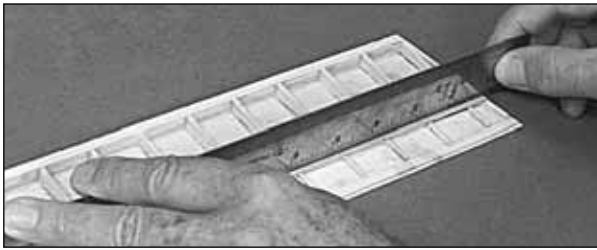

12. Lay the flap on a flat surface and glue a 1/32" x 3/16" x 18" **Plywood Cap Strip** to the top of each of the two stringers and to the LE (refer to the rib W-5 cross-section on the wing plan). **NOTE:** Hold the cap strips flat with a straightedge until glue cures. The Cap Strips make the flaps resistant to warping.



13. Glue the die-cut 1/8" balsa **Flap Hinge Doublers** to the flaps at the locations shown on plans.

14. Glue the die-cut 1/8" plywood **Flap Horn Plates** to the flaps at the locations shown on plans. **Note:** These are located in different bays on the right and left flaps.

BUILD THE AILERONS



1. Draw a center line on the die-cut 1/4" balsa **Aileron LE** and a line on each side 1/16" from the center line. Also draw a center line on the other side of the Aileron LE; this will help you "V" the leading edge later.

2. Place the die-cut 3/32" balsa **Aileron Base** on the plans and mark the "Rib Locations."

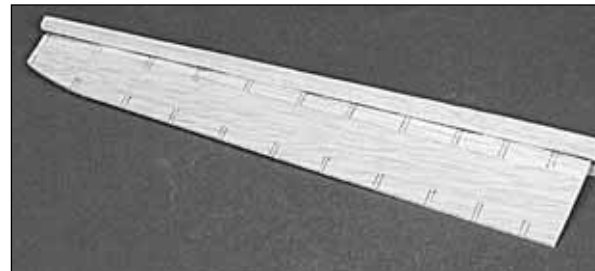

3. Place the Aileron Base between the lines you drew on the LE center line and glue with CA. **NOTE:** The Aileron LE is die-cut longer than the Aileron Base to allow final trimming on both ends.

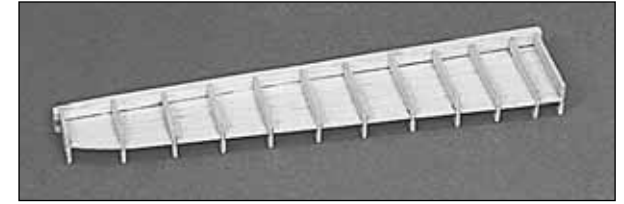

4. Cut "Ribs" from the 3/32" x 3/8" x 36" balsa sticks. Glue the Ribs to both sides of the Aileron Base between the marks.

5. Refer to the plans for aileron cross-section shape. Use a razor plane and a sanding block to shape the ailerons. Test fit the Aileron to the wing for final shaping.

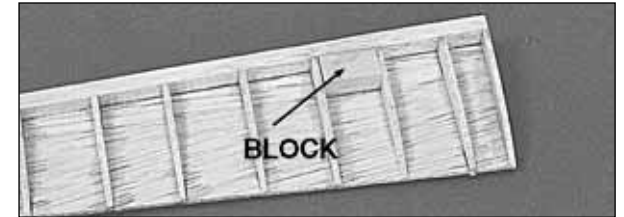

6. Refer to the plans for the **Aileron Control Horn Block** locations on the **bottom** of the ailerons. Glue the 3/8" x 1/2" x 7/8" hard balsa **Aileron Control Horn Blocks** in place.

7. Shape the Aileron Control Horn Blocks to match the aileron contour.

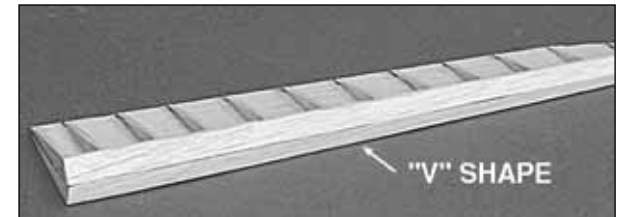

8. Shape the **Aileron LE** in a "V" shape to

allow proper aileron travel (refer to the cross-section at rib W-10 on the wing plan for the correct shape).

☐ 9. Tape the aileron to the wing and blend the aft portion of the wing tip and the aileron to create a smooth transition.

BUILD THE FUSELAGE

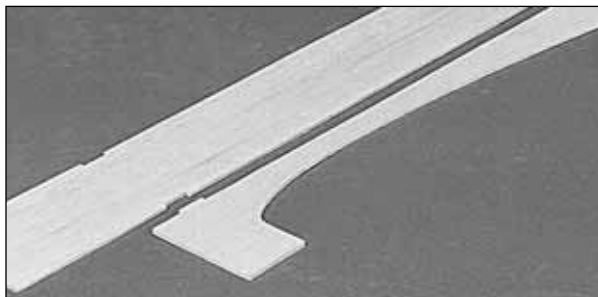

☐ 1. Test fit the shaped 1/8" balsa **Main Fuselage Side** to the die-cut 1/8" balsa **Lower Fuselage Side**. For a straight fuselage it is important to have the fuselage sides straight and both sides the same. Reassemble the parts and check them against the fuselage side view on the fuselage plan for proper alignment. Use CA and CA+ to glue the parts together. Use a quick wipe with a paper towel to remove any excess glue, as this will make sanding easier. Keep in mind that you are making a left and a right fuselage side.

☐ 2. Inspect the two fuselage sides. Choose the Right and Left sides so the best surfaces will face outward. Mark the inside of the appropriate part RI and LI (for Right Inside and Left Inside.)

IMPORTANT NOTICE: Compare the two die-cut 1/8" Plywood Fuse Doublers. Label the shorter one "R" (right) and the longer one "L" (left). This will set the right thrust in the firewall.

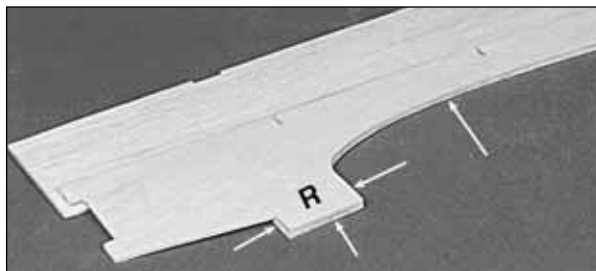

☐ 3. Glue the **Fuselage Doublers** to the fuselage sides. Use the wing saddle curve and the forward tab (see arrows) for proper positioning.

Tape the Fuselage Bottom View over your flat building board (we recommend cutting that part of your plan loose to make it easier to handle). Cover the bottom view with waxed paper.

Important Note: You are building the fuselage upside-down over the Bottom View. This aircraft has right thrust built in. Since the fuse is built upside-down, this will appear as left thrust until it is flipped over. Just follow the instruction sequence and everything will be fine.



☐ 4. Pin the die-cut 1/8" plywood **Forward Crutch** over its location on the plans. Make sure the front edge of the crutch matches the plans for the correct thrust angle.

NOTE: Some formers are not symmetrical and must be glued in with the proper orientation. Glue in all the formers with the identification numbers toward the FRONT of the model and they will all be correct.

☐ 5. Drill 3/16" holes through the punch marks in formers F-3, F-4, F-5, F-6, F-7, and F-8. These holes are for the pushrod routing and anchoring. You may confirm these locations using the cross-sections on the fuselage plans.

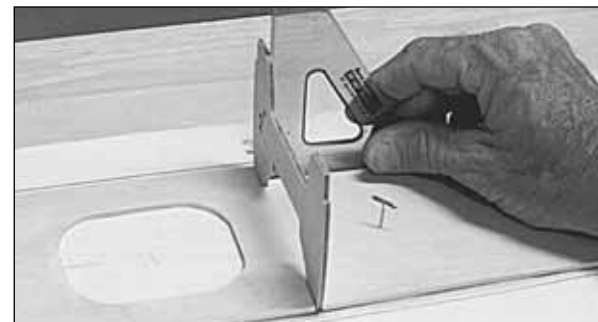

☐ 6. Glue the 1/8" plywood Former **F-3** to the forward crutch at its location on the plans. It should be perpendicular to the crutch with its number facing forward.

NOTE: It is helpful to keep some weight on the crutch while building the fuselage to keep it flat on the building board.

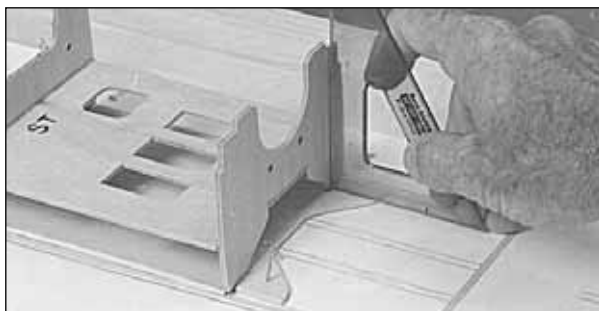

- ❑ 7. Glue in the die-cut 1/8" plywood Former **F-4** and the die-cut 1/8" plywood **Servo Tray (ST)**. F-4 must also be perpendicular to the crutch.

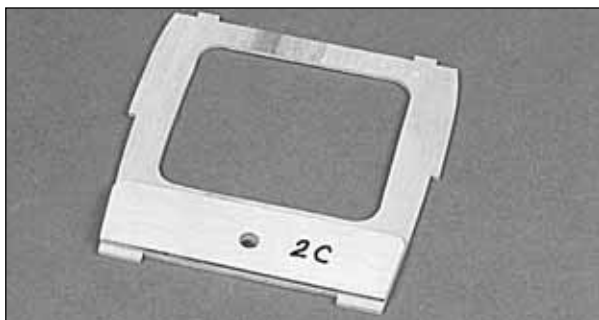

- ❑ 8. Glue the die-cut 1/8" plywood sub-former **F-2C** to the forward side of Former F-2. Make sure the dowel hole is aligned. Glue F-2 in place. F-2 must also be perpendicular to the crutch.

- ❑ 9. Place the die-cut 1/8" plywood Former **F-1B** in its location, but do not glue it since its slant is set by the fuselage sides. Test fit the die-cut 1/8" plywood **Chin Plate** on top of formers **F-1** and **F-2**.



- ❑ 10. Place the **Left Fuselage** side in position. Make sure its edge is down on the building board and tack glue it at the following places: the lock notch near the front of the crutch; the edge at the front of the wing saddle; the top of F-2, F-3, and F-4.

- ❑ 11. Work the **Right Fuselage** side into place. Check to see that all the notches are properly engaged and, if need be, make adjustments. Glue the Right Fuselage side at the same places you glued the Left Fuselage side in the previous step.

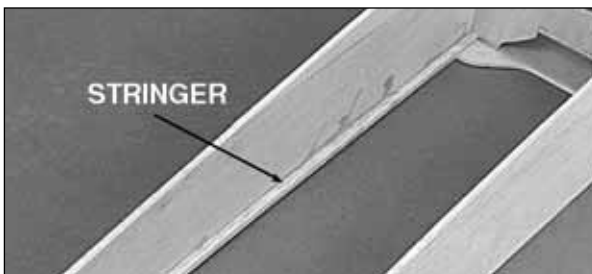

- ❑ 12. Locate two 3/16" x 3/16" x 18" balsa **Stringers**. They run from F-4 to F-8. Insert the stringers into the slots between the crutch and the fuselage sides. Glue the stringers along the edge of the fuselage sides next to the plans.

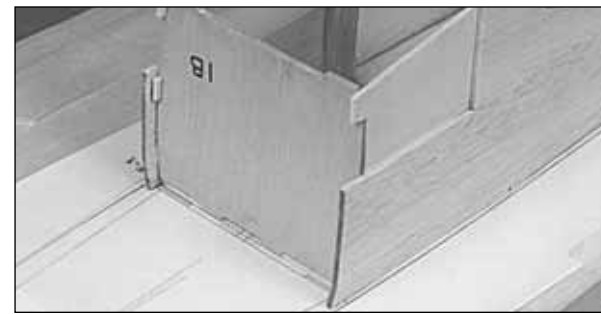

- ❑ 13. Place the die-cut 1/8" plywood Former **F-1B** between the fuselage sides. Check fit of the **Chin Plate**. Glue in Former F-1B, making sure it is seated flush with the tabs on the forward crutch and is positioned against the fuselage side doublers.



- ❑ 14. CA the **Chin Plate** to F-1B and F-2. **NOTE:** Check the angle on the forward edge of the Chin Plate, and make sure it matches the plans and the angle on the front of the crutch.



- ❑ 15. Epoxy the 1/2" x 3/4" x 7/8" hardwood

Fuselage Bolt Blocks into the notches in the fuselage side doublers at Former F-4. Use epoxy to make a small fillet around the sides of the bolt blocks. Also make an epoxy fillet between the bolt block and Former F-4.

❑ 16. Use CA+ to finish gluing the fuselage sides to Formers F-1B, F-2, F-3 and F-4.

❑ 17. Drill 5/64" holes through the forward two punch marks in the die-cut 1/8" plywood **Tail Wheel Plate (TW)**. Drill 1/8" holes through the two AFT punch marks for nylon tail wheel support pegs (see below).

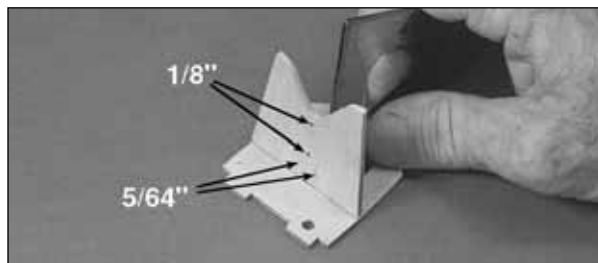

❑ 18. Glue the die-cut 1/8" plywood **Tail Wheel Plate (TW)** to former F-8, making sure they are perpendicular. Make sure the number on F-8 faces down.



❑ 19. Place the 5/8" long piece of 1/8" O.D. brass tubing over the top end of the wire. Squeeze the exposed end of the tube firmly with pliers to flatten it. Check the parts over the fuselage top

view to make sure they match up well. Silver solder the brass tube to the wire (see below).

TIPS FOR SILVER SOLDERING

Use this process when soldering metal to metal such as brass tube to wire, or pushrod ends to wire.

- Thoroughly clean the items to be soldered with alcohol or degreasing solvent.
- Roughen the area to be soldered with fine sandpaper, then clean again.
- Assemble the items to be soldered.
- Apply a small amount of soldering flux. Acid based flux works best when one or more of the items is steel.
- Heat the metal with a soldering gun or iron, and apply solder to the metal. The metal must get hot enough to melt the solder and the solder must flow freely into the joint.
- Do not move the parts until the solder has cooled.
- Clean off the excess flux with alcohol or solvent. Coat the parts with a very fine film of oil.
- Test the joint by pulling hard.

❑ 20. Mark the location for mounting the **Metal Ball** on the flat of the Brass Tube. Drill a 1/16" hole at the mark.

❑ 21. Attach the ball permanently on the tail gear with the **Small Nut** provided. Put a drop of 6-minute epoxy on the threads to prevent it from vibrating loose.

❑ 22. Use the **4-40 Set Screw** to set the collar at the height shown on the fuselage side view, but orient the set screw so small adjustments can be made later if required.

❑ 23. Roughen the tubular **Nylon Bearing** on the tail wheel wire with sandpaper so glue will stick to it.



❑ 24. Put a small drop of 6-minute epoxy on the Nylon Bracket where the bolt holes are. Screw the Nylon Bracket to **TW** with two **#4 x 3/8" Sheet Metal Screws**. Then put a drop of epoxy on the threads of the Sheet Metal Screws to prevent them from vibrating loose.



❑ 25. Pin the die-cut 1/8" plywood **Stab Support Crutch** to the plans at its location. The fuselage sides will protrude aft of the Stab Support Crutch by approximately 3/8". Glue F-8 to the front edge of the Stab Support Crutch; it should be perpendicular to the building board.

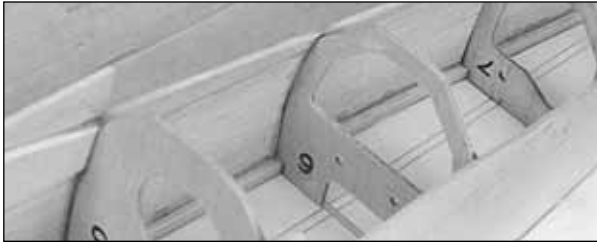

❑ 26. Glue in Formers **F-5**, **F-6**, and **F-7** at the locations marked on the plans. Make sure the formers are perpendicular to the building board. Pull the fuselage sides together at the aft end, and glue them to **F-8** and the **Stab Support Crutch**.

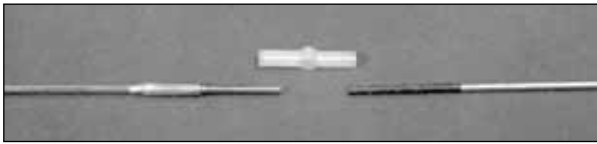

❑ 27. Cut 3" off one end of the **.074 x 35" Threaded Both End Rod**. Place a **brass Threaded Coupler** over the unthreaded end of the 3" piece. Measure the length of the assembly. Cut off the wire until the total assembled length is 3-1/2". Silver solder the brass coupler to the wire.

❑ 28. Screw the threaded end of the remaining 32" rod well into the end of the **Nylon Two-Ended Ball Link Socket**.

❑ 29. Cut out **Pushrod Tube** for rudder to the length shown on the plans and slide it through formers **F-8**, **F-7**, **F-6**, **F-5** and **F-4**. The **Rudder** outer pushrod tube protrudes through former **F-4** approximately 3/4" and through former **F-8** approximately 3/8". Roughen the outer pushrod tube at the formers so the adhesive will stick. Glue the pushrod tube in place with **CA+**.

❑ 30. Slide 5/16" lengths of **Inner Pushrod Tube** over the 32" pushrod wire. Space them approximately 2" apart. See the side view of the plans for proper spacings.

❑ 31. Insert the pushrod wire into the rudder outer tube and snap the ball link on the tail wheel steering arm.



❑ 32. Mark and cut out the rudder pushrod exit where shown on the fuselage plans. Bevel the exit with a sharp knife at the front from the inside and at the back from the outside.

NOTE: A Molded Hooded Pushrod Exit may be used instead of the outer Pushrod tube.

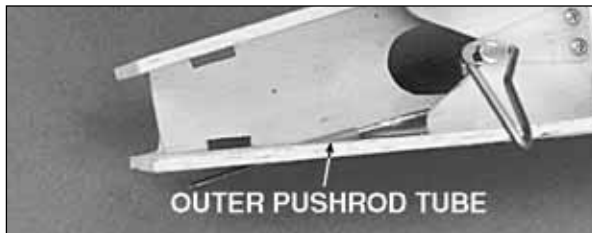

❑ 33. Cut a 1-1/4" piece of outer Pushrod Tube from the tubing supplied in the kit. Slide the tube into the pushrod exit slot through the fuselage side. Approximately 1/4" of the tube should be inside the fuselage. Trim the Pushrod Tube flush with the outside surface of the fuselage side. Glue the Pushrod Tube securely in place with **CA+**.

❑ 34. Screw the 3-1/2" piece of pushrod into the open end of the **Nylon Ball Link**. Position the brass coupler end so that it is inside the fuselage. Check the plans for the proper bend in the pushrod and bend to match.

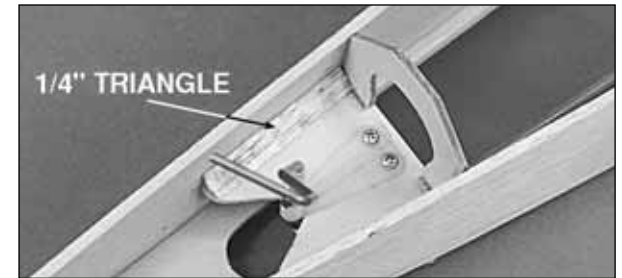

❑ 35. Cut two 2" lengths of 1/4" balsa **Triangle Stock** and glue them in place to reinforce the joints of **TW** and the fuselage sides.

❑ 36. Check all of the fuselage glue joints and re-glue any weak joints at this time.

BUILDING THE FUSELAGE TOP

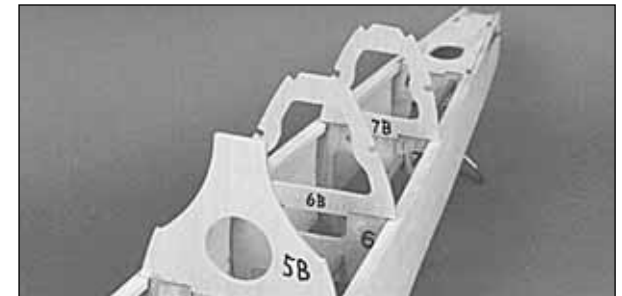

❑ 1. Glue the die-cut 1/8" **Former Tops F-5B**, **F-6B** and **F-7B** to the tops of their respective formers.

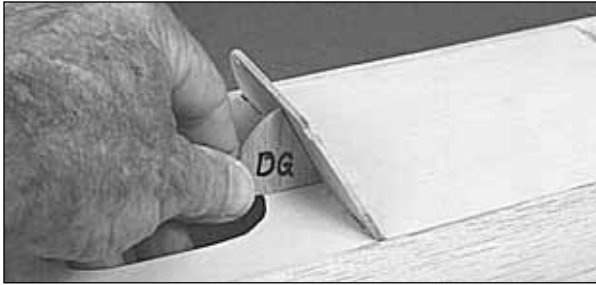

- 2. Use the die-cut 1/8" plywood **Dash Gauge (DG)** to set the angle of the die-cut 1/8" Former **F-3B**. Glue Former **F-3B** securely at set angle. Do not glue in the dash gauge.



- 3. Glue in the 1/8" die-cut plywood former top **F-2B**. Make sure F-2B is perpendicular to the crutch.
- 4. There are **punch marks** in the die-cut 1/8" plywood **Former F-1A** (Firewall). These locate the engine center lines. Draw lines connecting the points as shown in the photo at step 6.
- 5. The centerline of the engine is positioned on the horizontal and vertical lines on the firewall. The engine is offset to the left side of the model. This allows the spinner to be on the centerline of the model, despite the right thrust.

NOTE: The lines through the punch marks set the proper amount of engine offset and engine tilt to clear the exhaust header. Any changes must be

rotated about the intersection of the lines shown, which indicate the engine centerline.

NOTE: If you use the included adjustable engine mount, place it on the engine to determine proper spacing. You should use the 4 holes indicated by the punch marks on F-1A regardless of the width the mount is adjusted to. In most cases, you will be required to use the included spacer plates when using this mount. Refer to the fuselage bottom view on the plans for a typical 2-cycle installation.

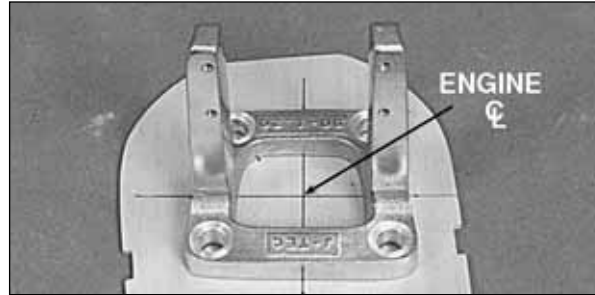

- 6. Mark the locations of the mounting bolts for your engine mount. **NOTE:** If using the adjustable engine mount, make sure the centerline on the firewall is centered between the "tick marks" on the mount. You may find it convenient to also mark locations for the fuel lines and the throttle pushrod at this time. Epoxy F-1A in place and drill pilot holes for the engine mount bolts. **NOTE:** Photo shows J-Tec JT-122(SV) engine mount.
- 7. Slide **F-1C** into place behind F-1A. The tops of F-1A and F-1C should be even. Make any adjustments to F-1C until it fits well. Glue F-1C in place.
- 8. Install the 1/8" x 3/4" x 3" **Firewall Backup** strips to backup the firewall where the bolts for your mount pass through. Refer to the firewall cross-section on the plans for a typical location.

- 9. This is a good time to apply fuel proofing inside the nose section. 30-minute epoxy works great for this.

- 10. If you have all your engine mount parts available, install them temporarily now and pull in any blind nuts, etc., into place.

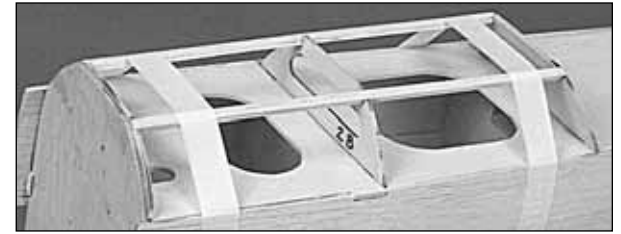

- 11. Cut a 3/16" x 3/16" x 24" balsa **Stringer** in half. Install the Stringers in the slots on the top of the fuselage.

- 12. Cut the **Forward Deck Sheeting** out of 3/32" x 2-1/4" x 24" balsa sheet. **NOTE:** The Fwd Deck Sheeting at the base of the dash extends approximately 1/4" aft (see plans). The sheeting should extend past the firewall and be trimmed square to the fuselage sides about 1/4" in front of the firewall.



- 13. Glue a Forward Deck Sheet to the fuselage along the top edge of the fuselage side. Wet the deck sheeting using a damp paper towel. Apply CA+ to the formers and stringers. Bend the wood around and attach it to formers **F-2** and **F-3** first. You may hold the sheeting in place with masking tape.

- ❑ 14. Bend the sheeting around so it conforms with F-1. Apply some additional CA to the joint.
- ❑ 15. Trim the sheeting to the edge of the stringers along the top edge of the forward deck.



- ❑ 16. Sand the sheeting and the stringers to match the flat tops of formers F-1, F-2 and F-3.
- ❑ 17. Test fit the 1/4" x 3" x 12" **Fwd Deck Top** to the top surface, and then glue it in place. Make sure the Fwd Deck Top's aft edge lines up with Fwd Deck Sheeting's aft edge towards the cockpit. Trim the front end of the Deck Top even with the sheeting near the firewall. Refer to the Fuselage Side View on the plans.

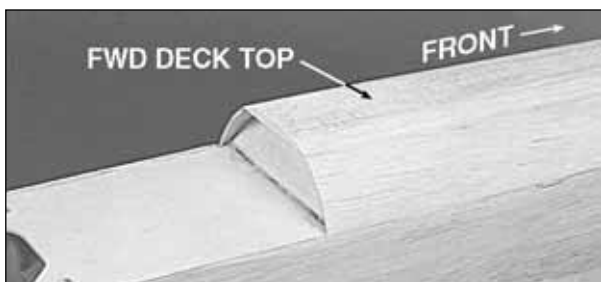

- ❑ 18. Refer to the plan cross-sections for shaping the **FWD Deck Top**. Use the canopy to assist in final shaping. **NOTE:** There is a transition from the canopy to the firewall from a fairly flat Deck top shape at the Canopy to an almost round one at the firewall. Use a razor plane and sanding block to shape the FWD Deck Top.

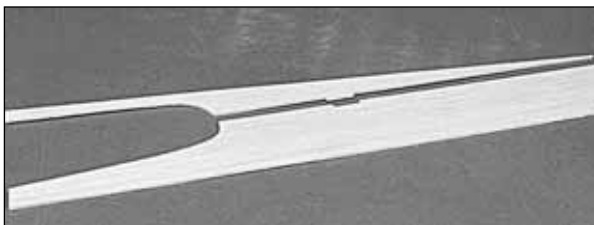

- ❑ 19. Test fit the two die-cut 3/32" balsa **Upper Aft Fuselage Side** sections together and make any necessary adjustments. Glue the two pieces together and lightly sand both sides.

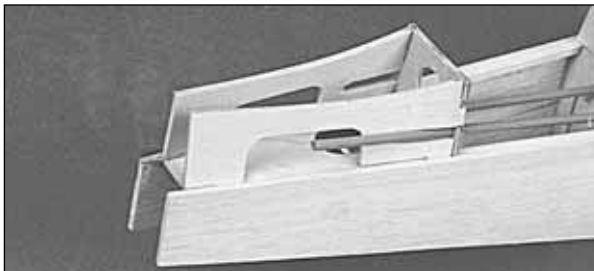

- ❑ 20. Glue in the die-cut 1/8" plywood former **F-8B** and the two die-cut 1/8" plywood **Stab Supports**. Make sure F-8B is locked onto the forward tabs of the Stab Support. The Stab Supports must be well seated since they set the stab incidence.

- ❑ 21. Insert the elevator Outer Pushrod Tube through the slot in the stabilizer support, F-8, F-7, F-6, F-5, and F-4. The tube must extend approximately 3/4" through Former F-4. **NOTE:** The Elevator Pushrod Tube must extend far enough past the stabilizer support so it can be trimmed flush with the outside of the Upper Aft Fuselage Side. See photo in step 20.



- ❑ 22. Glue the 3/16" x 3/16" balsa **Stringers** in the slots provided in **Formers F-6B, F-7B and F-8B**. **NOTE:** The top two stringers are 18" long and extend forward past former F-6B approximately 3" and aft beyond former F-8B approximately 1". The top two stringers will extend past the length of the top block at former F-8B. The side stringers are cut from a 24" stick and run from former F-6B to F-8B and interlock with the Stab Supports.



- ❑ 23. Sand the tabs on **Former F-8B** where it locks to the Stab Supports until the side edge of F-8 is cut down even with the sides of the Stab Supports.
- ❑ 24. Hold the **Upper AFT Fuse Sides** in place and check the fit. Sand the bottom edge until they fit properly. Install die-cut 1/8" ply Former **F-4B** in place at the angle shown on the fuselage side view on the plan.

NOTE: *There will be a small ledge where the upper aft fuse side mates with the main fuse side. This will be sanded away in the final sanding.*

- ❑ 25. Glue the Upper Aft Fuse Sides at their bottom edge only with CA.



- ❑ 26. Moisten the Upper Aft Fuse Sides with a damp paper towel. Form both the right and left Upper Aft Fuse Sides against the formers and hold in place with long strips of masking tape.

- ❑ 27. Glue the Upper Aft Fuse Sides to the formers and stringers.

- ❑ 28. Glue the Upper Aft Fuse Side to the corners of former F-4B.

- ❑ 29. Sand the **Upper Aft Fuse Sides** and **Stringers** flat down to the tops of the formers. **NOTE:** The fuselage sides around the side window cutouts become very thin. Use caution so they will not break away.

- ❑ 30. Place the 1/4" x 1-1/2" x 18" balsa sheet on top of the Upper Aft Fuselage Sides. Check the plans for the proper length. Hold in place and trace along the Upper Aft Fuselage sides onto the 1/4" balsa sheet. Rough cut the Aft Deck Top to shape

NOTE: The Aft Deck Top is constructed of two separate blocks because of the change of angle along the top surface.



- ❑ 31. Glue the aft portion of the **Aft Deck Top** to the fuselage. Use a razor plane and sanding block to shape edges of the Deck Top to blend with the fuselage sides. **NOTE:** Do not round the top surface at this time.

- ❑ 32. Cut the front portion of the Aft Deck Top from the remaining piece of the 1/4" x 1-1/2" x 18" balsa sheet. Match the ends of the two Deck Top Blocks for a good joint and glue in place.

- ❑ 33. Shape the forward section of the Deck Top to match the fuselage sides as you did in step #29. Do not round the top surface at this time.



- ❑ 34. Trim the vacuum formed **Window Recess** parts and test fit into the openings. The openings in the fuse sides may need enlarging for a proper fit.

NOTE: There is a Left and Right Window Recess part.

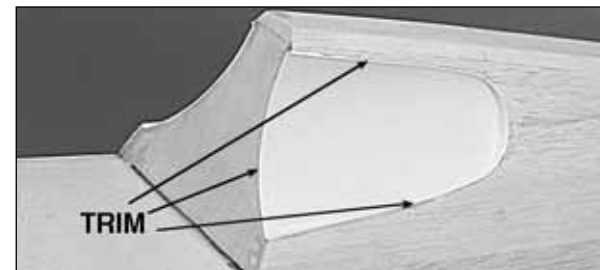

- ❑ 35. Glue the Window Recess Inserts in place and trim to match the fuse sides and Former F-4B.



- ❑ 36. Cut the **Cockpit Side Rails** from the 1/8" x 5/8" x 6-1/4" balsa sticks. Glue the side rails in place where shown on the Side View on the Fuselage Plans.

- ❑ 37. Shape the Cockpit Side Rails to blend into the fuselage sides.

- ❑ 38. Finish shaping the Aft Deck Top to the contour shown on the plans. Use a razor plane and sanding block for final shaping. Trim the canopy to the proper shape (refer to page 51 for a photo of the trimmed canopy). Check the fit of the canopy to the fuselage and adjust the fuselage as required for a good fit.

MOUNT THE WING TO THE FUSELAGE

❑ 1. Run a 5/16" drill through Formers F-2 and F-2C to clean out the holes so the dowel will fit through.

❑ 2. Round the ends of the 5/16" Diameter x 3-1/8" hardwood **Wing Dowel**.

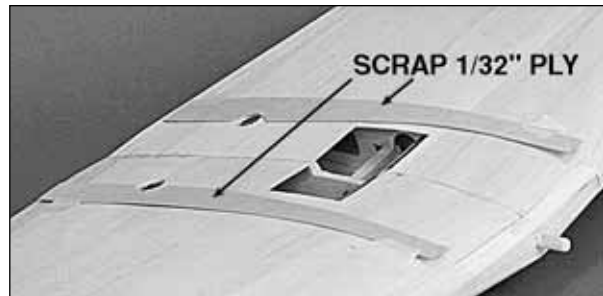

❑ 3. Tape some scrap 1/32" plywood (from the wing fillet base die-cut sheet) to the wing skin where it will intersect the fuselage to simulate the die-cut 1/32" plywood Fillet Base. Test fit the wing to the fuselage. If there is much interference preventing the wing from comfortably fitting down on the saddle, shape the wing dowel hole in F-2 oblong and adjust the dowel slot in the wing structure until the interference is gone.

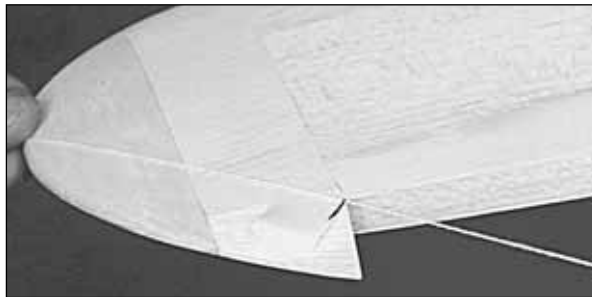
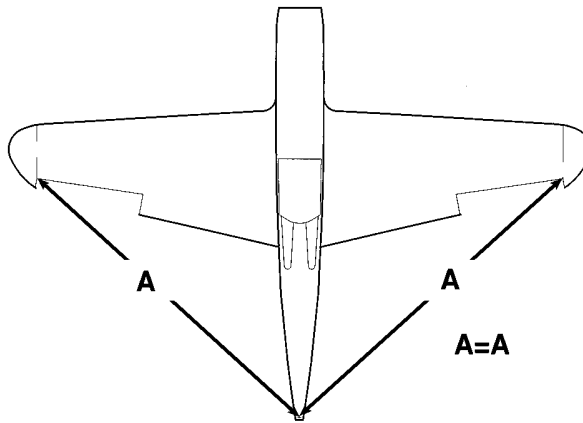

❑ 4. Put the wing in position on the fuselage. Hold a string (with one end attached to a pin at the tail) up to one of the wing tips. Put a piece of tape on the string to mark the intersection of the string and the wing tip. Swing the string over to the other wing tip and check to see if the distances are the same (see diagram). Adjust the position of the trailing edge of the wing until the wing is properly aligned.

NOTE: Make sure the wing is held securely and cannot shift while you are drilling the mounting holes.



❑ 5. With the wing aligned and taped in place, mark the center of the wing mount holes on the mount blocks with a #10 (or 13/64") drill.



❑ 6. Remove the wing to prevent damage to the wing and mounting holes. Finish drilling the holes

with a #10 (13/64") drill bit through the wing mount blocks. Tap the holes with a 1/4"-20 tap.

ATTACH THE STAB AND FIN

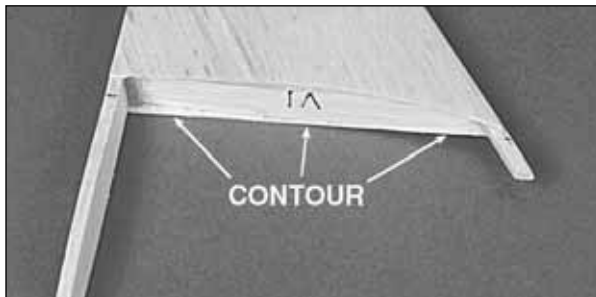

❑ 1. Contour the fin sheeting that protrudes past **V-1** to fit against the top of the horizontal stabilizer. Use the photo and the plans as references.



❑ 2. Test fit the fin and stab to the fuselage. The notch in the trailing edge of the stab should align with the plywood Stab Supports as shown in the photo. Make slight adjustments to the fuselage as required for a good fit.

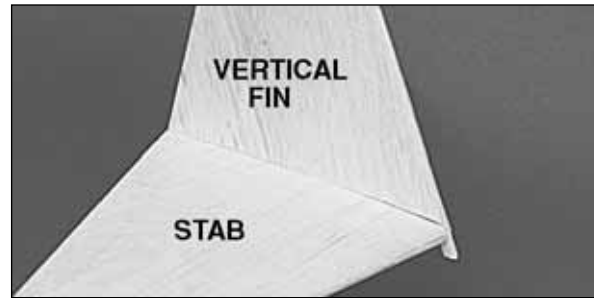

❑ 3. Glue the fin to the stab with 30-minute epoxy. Make sure they are properly aligned and perpendicular to each other. Allow the epoxy to cure.

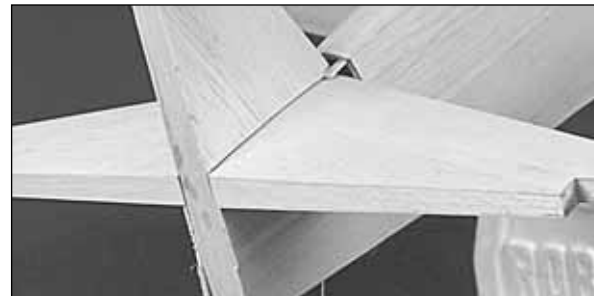

❑ 4. Glue the Stab/Fin assembly to the fuselage. View the plane from the top and the rear. Make sure the stab and fin are properly aligned with the wing and fuse. Use epoxy in the stab saddle area. CA may be used to glue the fin post to the fuselage sides.

❑ 5. Inspect the joint of the stabilizer and the plywood stab supports through the open bottom of the fuselage. If the joint does not appear to be well glued, apply a small fillet of 30-minute epoxy to the joint.

BUILD FUSELAGE BOTTOM

❑ 1. Use the pattern on the plans to assist you in cutting out the **Aft Fuselage Bottom** from the 1/8" x 2-1/4" x 24" balsa sheet.

❑ 2. Drill a 1/8" hole in the die-cut 1/8" plywood **Tail Wheel Support** at the punch mark location. Place the **Tail Wheel Support** over the tail wheel wire. Leave the support loose at this time.

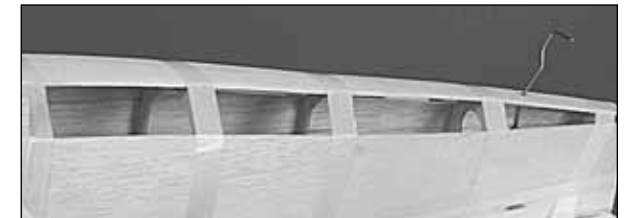

❑ 3. Align the **Aft Fuselage Bottom** on the formers F-5, F-6, F-7, F-8 and the Fin TE. Wet the outside surface of the sheeting. Use tape to hold the sheeting in place after it is formed properly.

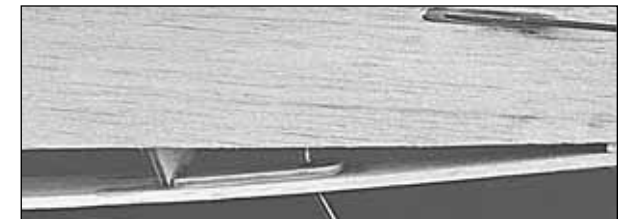

❑ 4. Glue the **Aft Fuselage Bottom** to formers. Use epoxy to glue the Tail Wheel Support to F-8 and the **Aft Fuselage Bottom**.

❑ 5. Sand the fuselage sides and the Aft Fuselage Bottom at an angle that matches the formers to provide a flat surface for the corner blocks to set on.

❑ 6. Cut the **Corner Blocks** from the 1/4" x 2-1/2" x 24" balsa blocks. Use the pattern furnished on the plans.



❑ 7. Fit the Corner Blocks and glue them in place. Use a razor plane and a sanding block to shape the bottom of the fuselage. Check the plans for the proper contour.

BUILD THE TOP COWLING

NOTE: The sequence below shows the installation of an O.S. 1.20 Surpass 4-cycle engine with pump on a J-Tec JT-122SV shock absorbing mount. See fuselage plan for an alternate engine installation.

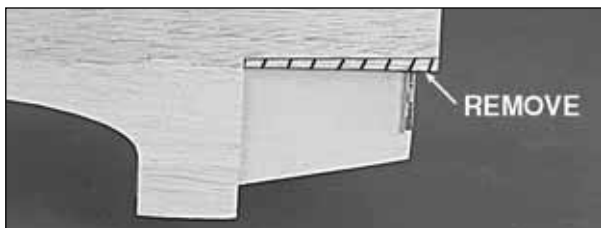

❑ 1. Measure the hatched area on the plans for the dimensions of the notched area of the fuselage

sides to be removed. **NOTE:** The hatched sections of balsa must be removed from both sides of the fuselage to allow proper alignment between the fuselage sides and the cowl sides.

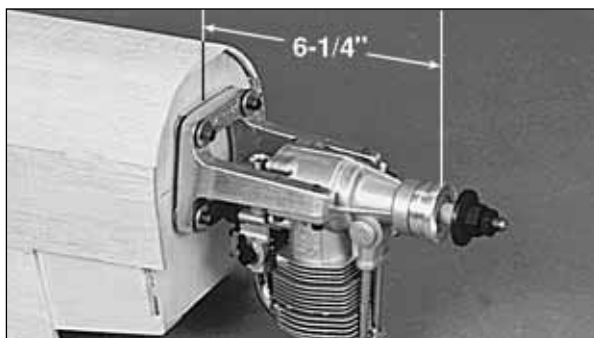

❑ 2. Bolt the Engine Mount to the firewall. If the mount you are using is different than the J-Tec JT-122(SV), please refer to the bottom view of the plans for an optional installation. **NOTE:** All engines must be positioned so the thrust backplate is 6-1/4" from the centerline marked on the firewall.

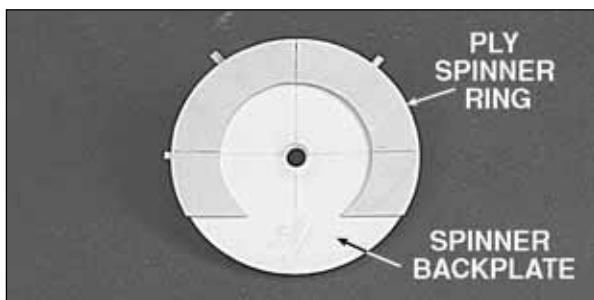

❑ 3. Draw a line between the "punch marks" on the die-cut 1/16" plywood **Spinner Ring**. This is the center line of the spinner.

❑ 4. Glue scraps of 1/16" (or 3/32" for soft mounted engines) balsa to the spinner ring to act as a spacer for the spinner.



❑ 5. Tack glue the spacers on the spinner ring to the **Backplate** of the spinner. Mount the spinner backplate to the engine.

❑ 6. Align the Spinner Ring bottom level with the fuselage structure as shown in photo.



❑ 7. Trim the shaped 1/2" balsa **Cowl Sides** so they fit between the fuselage sides and the spinner ring. The bottom of the sides should be aligned with the fuselage sides and the bottom of the spinner ring. Notice on the **top view** of the fuselage plans how the cowl sides protrude outward from the structure about 1/8" at the spinner ring and at the firewall to allow for shaping. **Note:** Make sure that you do not get the cowl sides mixed up with the cowl corners, used in step 11 on page 39. The cowl corners are symmetrical, the cowl sides are not. If the bottom edges do not line-up properly, as shown in the photo, you are most likely using the wrong part.

❑ 8. Tack glue both of the Cowl Sides in place. View the cowl sides and the spinner ring from the front to make sure they are on straight. Securely glue the Cowl Sides in place.

- ❑ 9. Fit the shaped 1/2" balsa **Cowl Top** in position. Glue securely in place. **NOTE:** Remove the engine from the mount to prevent any chips or sanding dust from entering the engine.



- ❑ 10. Carefully cut the corners of the cowl sides and cowl top at an angle as shown in the photo. Use a sanding block and coarse sandpaper to finish making a flat area for the Cowl Corners to fit on.



- ❑ 11. Adjust the shaped 1/2" balsa **Cowl Corners** so they fit as shown. Glue the corners in place.

NOTE: Shape the cowl blocks from the center of the blocks towards the fuselage and from the center of the blocks towards the spinner ring. The most material removal is at the ends of the blocks.



- ❑ 12. Use a razor plane and a sanding block to shape the nose. You will want to use the spinner and the vacuum formed scale carburetor intake to check for correct shape.

BUILD THE WING FILLET

NOTE: There are many techniques to build a wing fillet. Some modelers prefer to carve the entire fillet from balsa, others use a mixture of epoxy and micro balloons to finish the fillet. If you have a favorite technique, feel free to use it. The technique described below works fine for most modelers.

- ❑ 1. Remove the die-cut 1/32" plywood **Wing Fillet Bases** from their blanks. Clean up all edges if necessary.

NOTE: There is left and right wing fillet. The left wing fillet is die-cut in one piece. The right wing fillet pieces may be taped together and then glued in place at time of installation.



- ❑ 2. Tape a layer of **Waxed Paper** or plastic food wrap to the top surface of the wing in the wing saddle area (the shims used earlier to simulate the thickness of the fillet base in earlier steps should be removed). Bolt the wing onto the fuselage. Check to make sure there are no misfits in the wing saddle and make adjustments if needed.

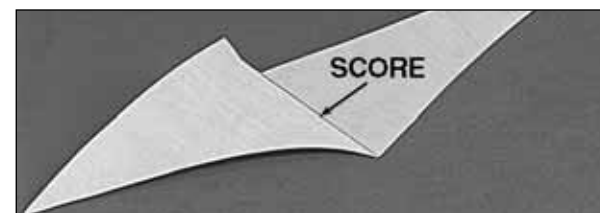

- ❑ 3. Score the bottom of the 1/32" plywood **Wing Fillet Base** as shown in the photo. Do not cut more than 1/3 of the way through the plywood fillet base. Crease wing fillet bases on score line slightly. **NOTE:** The score line on the wing fillet bases are at the TE of the wing.

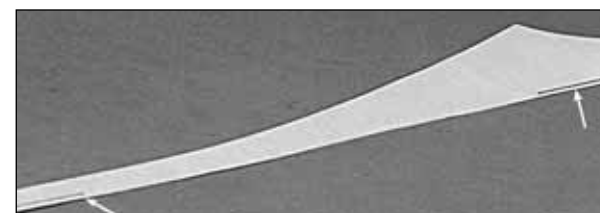

- ❑ 4. Mark the inside edge of Wing Fillet Base approximately 1/8" in from edge at the front and back of the fillet base.

5. Loosen the wing bolts and slide the Wing Fillet Bases between the fuselage and the wing on both sides of the fuselage. **Align** the fillets to the 1/8" marks and tighten the wing bolts firmly. **NOTE:** The wing fillets must be built with the wing bolted in place to obtain the correct wing dihedral angle.

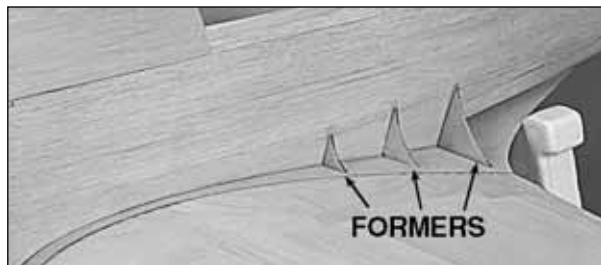

6. Position the die-cut 1/8" plywood **Wing Fillet Formers** at the locations shown on the plans. There are three formers per side. Glue the formers in place.



7. Glue the wing fillet to the wing saddle area of the fuselage. The part of the wing fillet that is behind the wing is easier to glue with the model inverted.

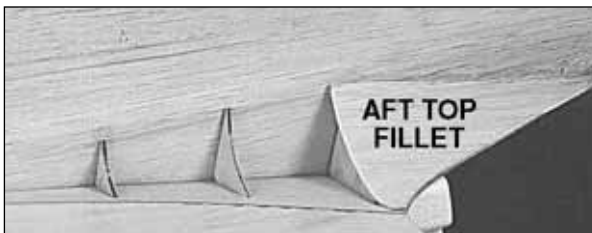

8. Use the pattern furnished on the plans to cut the two **Aft Top Fillets** from 1/16" balsa sheet. Test fit them between the fuselage side and the wing fillet base. Check the cross-sections on the plans for the proper fillet curve.

9. Sand the **Aft Top Fillets** for proper fit and feather the edges to match the fuselage sides and the wing fillet bases. Glue the fillet in place and make sure the fillet is conformed to the fillet formers and matches the wing fillet base edge.



10. Use the pattern furnished on plans to cut the two **Forward Fillets** from 1/16" balsa sheet. Test fit the Forward Fillets to the wing and the fillet base.

11. Match the Fwd Fillet to the Aft Fillet and glue in place. Make sure the two fillet ends match for a smooth transition.

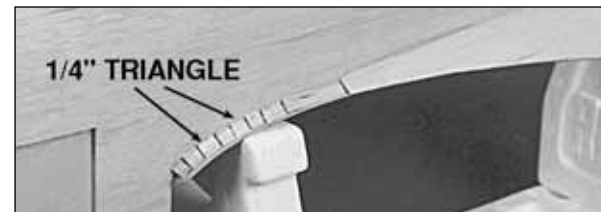

12. Cut short sections of 1/4" balsa triangle to use as fill for the remaining area on wing fillet base. Glue the triangle sections in place.



13. Use the pattern furnished on plans to cut the two **Aft Bottom Fillets** from 1/16" balsa sheet. Glue the Aft Bottom Fillets to the 1/32" plywood Fillet Base and to the bottom of the fuselage as shown in the photo.



14. Fill all seams and contour the fillet as shown in the photos. **NOTE:** Hobbico Hobblyite filler was used on the model in the photo.

BUILD THE WING BELLY PAN

- ❑ 1. Check the plans for the locations of die-cut 1/8" plywood **Belly Formers B-1, B-2, B-3, B-4** and **B-5**. Mark locations on the bottom of the wing.



- ❑ 2. Position the formers at the locations marked on the wing. **TIP:** Use a 3/16" square balsa stringer to assist in alignment of the formers to the centerline of the fuselage.

- ❑ 3. Glue the 3/16" square stringer to all formers. Cut the stringer off flush with the front of Former B-1 and the back of Former B-5.

If you are installing a drop tank, make provisions to install the drop tank now. Refer to the fuselage side view on the plans for more details of the drop tank and cable release installation. (The drop tank kit includes instructions for tank assembly.)



- ❑ A. Reinforce the 3/16" stringer as shown.

Make a slot for the forward tab on the release mechanism (the aft tab must be cut off).

- ❑ B. Route a thin cable to the tank release servo. Tin the cable with silver solder at the release end and put a Z-bend in it. See the fuselage plan.

- ❑ C. Test fit the Release to the bottom of the belly pan and drill holes for the #2 mounting screws. Remove the release. It should be reinstalled during final gear-up.

- ❑ 4. Use the pattern provided on the plans for cutting the sheeting from 1/16" balsa sheet.



- ❑ 5. Test fit the balsa sheeting at the center of the stringer and check the edge mating to the wing. Wet the sheeting with a wet paper towel to assist in forming the sheeting. Glue the sheeting in place.

NOTE: The seam at the wing and belly sheeting will require filler to provide a smooth transition from the belly pan to the wing.

- ❑ 6. Glue the shaped 1/4" balsa **Front Belly Pan Block** to Former B-1. **NOTE:** The front block must be flush with the LE of the wing. Shape the Front Belly Block to match sheeting of the Belly Pan. Filler may be used to blend the front Belly Block into the wing LE. Sand the edges of the Front Belly Block to form a radius of approximately 3/16" to provide good cooling airflow.



- ❑ 7. Shape the Aft Belly Block and glue in place. Final sand the Aft Belly Block to blend into the contours of the Wing Belly Pan. **NOTE:** Mark contour on the front of the Aft Belly Block, using the Former B-5 as a guide.

FIT THE FLAPS

Do these steps for operating Flaps



- ❑ 1. Mark the locations of the pivot hinges on the wing and flap. Check the wing plans (including the cross-section) for locations.

- ❑ 2. Use a T-bar to sand the edges of the sheeting flush with the Aft TE at flap.



- ❑ 3. Test fit the flap in the wing opening. Check the ends of the flap for approximately 1/16"

clearance. The TE of the flap must match the wing TE. **NOTE:** The flap should lay flat against the trailing edge of the wing.



4. When the fit is good, install the pivot hinges (GPMQ4002). Drill 1/8" holes at the hinge locations. Use a sharp #11 knife to cut a notch in the leading edge of the flap at the hinge locations. This will allow the pivot hinge pivot point to be in the **center of the radius of the flap LE** (refer to the cross-sections on the wing plan).

***NOTE:** The hinges are not glued in until after the finish has been applied.*



5. Plug the flap with the hinges into the wing. Check its fit and run the flap through its complete range of motion. Make any required adjustments until the flap swings freely through its range of motion (remember the flap must close against the wing TE).

BUILD THE COWL

NOTE: The general procedure for the preparation of vacuum-formed plastic parts is as follows...

- A. Examine the part carefully to find the molded-in cut-off lines. These lines are visible on the inside.
- B. To avoid cutting away too much material, start by cutting away just the excess material, but staying approximately 1/8" away from the marked cut-off lines. A small hobby scissors, designed for cutting plastic, works very well for making these initial cuts.
- C. Then carefully trim the plastic down to within 1/32" of the molded-in cut-off lines. You can use various straight and rounded sanding blocks to true up the edges.
- D. Trial fit the parts together and sand the edges as necessary to achieve a good fit.



1. Mark the two vacuum formed **Cowl Halves** approximately 1/8" from molded in trim line. Be careful not to cut off the lap joint on the bottom of the right cowl side. Check trim lines closely to make sure you are allowing some excess material outside the trim lines. Removal of the excess plastic will allow for easier fitting and final trimming.



2. Trim the **Cowl Front** vacuum formed part as you did to the Cowl Halves.

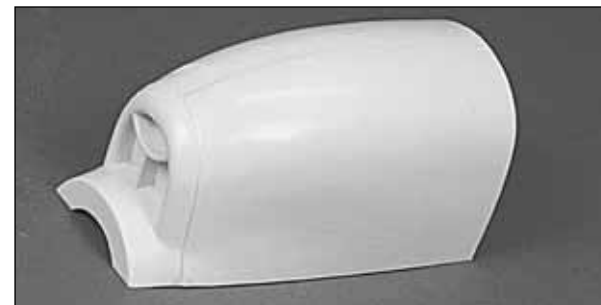
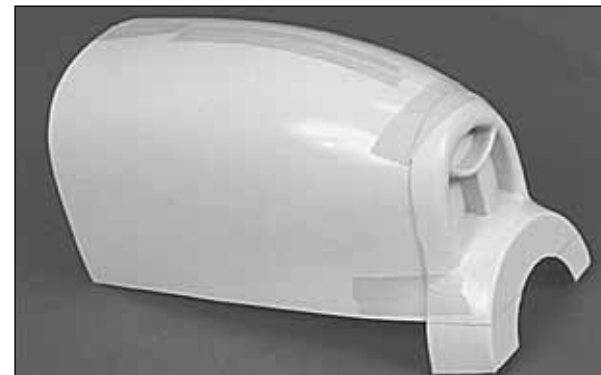

3. Tape the Cowl Halves and the Cowl Front together for a test fit. Check all parts and their trim lines for alignment. **NOTE:** The Cowl Halves overlap at the bottom and the Cowl Front overlaps both Cowl Halves.

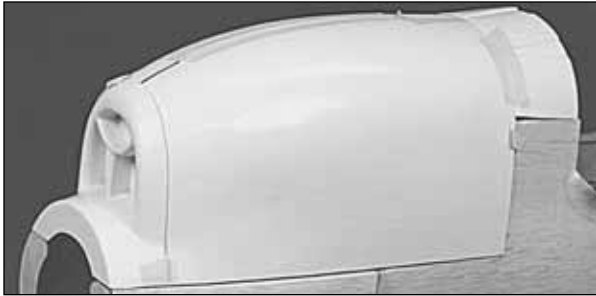

- ❑ 4. Test fit the taped together parts on the fuselage. Trim the cowl parts as necessary for a better fit.
- ❑ 5. Tack glue the cowl halves and cowl front together. Remove all tape and finish gluing all parts together.
- ❑ 6. Place the cowl on the fuselage and check the fit. Finish trimming the perimeter of the cowl so it fits well on the fuselage.
- ❑ 7. Sand the entire cowl with #220 grit sandpaper. The glossy finish on the plastic parts must be roughed up slightly to allow the filler and primer to stick properly.

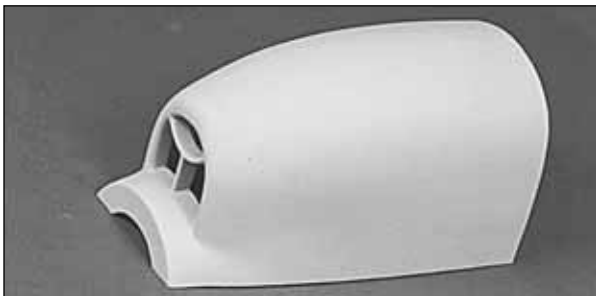

- ❑ 8. Use “**BONDO®**” (Automotive Body Filler) or a filler of your choice to fill the seams of the plastic parts. Keep the amount of filler to a minimum because of weight.

- ❑ 9. Cut out the three recessed Air Intake Ports in the cowl front. These ports must be open to allow air flow for engine cooling.

- ❑ 10. Trim the vacuum formed **Cowl Flaps**. Make sure you begin by trimming approximately 1/8” outside the finished trim line.



- ❑ 11. Place the main cowl on the fuselage and tape in place. Hold the Cowl Flaps in place and mark both sides to match the fuselage sides. **HINT:** Align the cowl flaps to the main cowl with the center recessed area on the cowl flaps centered on the seam of the main cowl.

- ❑ 12. Glue the Cowl Flaps in place when they are aligned with the fuselage.

- ❑ 13. Sand the inside of the **Cowl** with a coarse sandpaper to roughen the plastic so epoxy will adhere. Clean the inside of the main Cowl with alcohol to remove all dirt and sanding dust.

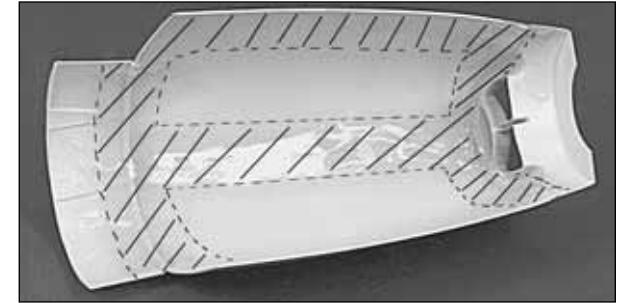

- ❑ 14. Apply the strips of **Fiberglass Cloth** (provided) with 30-minute Epoxy to reinforce all internal seams **and edges** of the cowl assembly.

- ❑ 15. Spray the finished sanded cowl with a sandable primer. **NOTE:** It is very important to use a primer that is compatible with the type of paint to be used for the final finish.

- ❑ 16. Place the cowl assembly on the fuselage and mark the locations for the mounting holes. If the engine is installed also mark the location for the needle valve clearance hole. The access hole for the Glow plug can be eliminated by using a remote Glow Plug Adapter.

- ❑ 17. Mark the Cowl mounting hole locations on the Fuselage. Adjust the location of the front holes if required to clear your engine or exhaust system.



- ❑ 18. Glue in the 1/4” plywood **Forward Cowl Mount Blocks** at the location you marked. Make shims for the aft part of the cowling as shown in the photo from scrap 1/32” or 1/16” plywood.

BUILDING THE LANDING GEAR PODS

❑ 1. Match the vacuum formed Landing Gear Pod parts. There are two parts to each pod and there is a **Left** and a **Right** of each part. Look at the photos for assistance in matching the parts.



❑ 2. Trim the landing gear pods approximately 1/8" from trim line to remove excess plastic. Then carefully trim down to the trim lines.



❑ 3. Test fit the **Pod Bottom** and the **Pod Front** together. There is a lap joint where the front

overlaps the bottom. Trim the Pod Fronts exactly to the trim lines where the two parts fit together.



❑ 4. Glue the Pod Front to the Pod Bottom, removing any tape you may have used to hold the parts together.



❑ 5. Test fit the pod assembly to the wing. Sand the inside edge of the overlap joint if necessary until the part lies flat on the wing surface.



❑ 6. Fill the seam with "**BONDO**" (Automotive Body Filler) or a filler of your choice. Sand smooth and spray with a primer that is compatible with the paint you are going to use for the finish.



❑ 7. Place the pod assembly over the landing gear mount on the wing and trace the opening that is needed to clear the "Fixed" or "Retractable" gear struts.



❑ 8. Cut out the opening in the pod assembly required for your type of landing gear. **HINT:** Cut the opening as small as possible to start with. The opening can be made larger easier than it can be made smaller.



9. Place the die-cut 1/8" plywood **Pod Mounts** at the rear of the gear pods, against the landing gear support braces. The gear pods must be installed over the landing gear mounts on the wing. Tack glue the plywood Pod Mounts to the Gear Pods.

10. Mark and Drill 1/8" clearance holes in the Pod Mounts only.

11. Install the Gear Pods over the landing gear mounts on the wing. Transfer the mounting holes of the pod mounts to the landing gear supports on the wing.

12. Drill 5/64" holes in the landing gear supports. Use #4 sheet metal screws to secure the landing gear pods in place.

FINISH PREPARATION

FINAL SANDING

Nearly every imperfection in your wood structure will show through the covering material; therefore, before covering, you should make a final check of the entire structure. Fix any "dings," then sand the entire structure smooth using progressively finer grades of sandpaper.

FUEL PROOFING

Fuel proofing may be done after covering.

1. Fuel proof the firewall area and the inside of the cowl top. Grey (mix black and white) K&B epoxy paint or 30-minute epoxy is recommended.

2. Fuel proof the inside of the fuselage forward of F-3 and the wing saddle area. 30 minute epoxy and a bent epoxy brush was used for this on the prototypes.

3. Fuel proof any external exposed wood (e.g., flap pushrod exits).

BALANCE THE AIRPLANE Laterally

SPECIAL NOTE: Do not confuse this procedure with "checking the C.G." or "balancing the airplane fore and aft." That very important step will be covered later in the manual.

Now that you have the basic airframe nearly completed, this is a good time to balance the airplane **laterally** (side-to-side). Here is how to do it:

1. Temporarily attach the wing and engine (with muffler) to the fuselage.

2. With the wing level, lift the model by the engine propeller shaft and the fin post (this may require two people). Do this several times.

3. If one wing always drops when you lift the model, it means that side is heavy. Balance the airplane by gluing weight to the other wing tip. **NOTE: An airplane that has been laterally balanced will track better in loops and other maneuvers.**

RETRACTS

1. Mark on the lower wing skin the location of your strut and tire. Make a small cut-out to confirm the correct location.

2. Gradually increase the size of the cut-out until the strut and wheel fit properly.

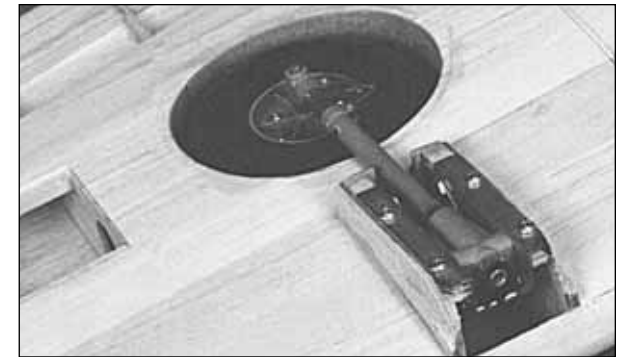

4. You may make wheel well liners from vertical grain 1/64" plywood (supplied) -OR- you may leave your wheel wells open.

5. Fuel proof the inside of the wing.

6. Hook up the air lines to the retracts and route them to the center of the wing.

7. Bolt in the retracts, hook them up, and test their operation.

FINISHING

The P-40 requires painting to obtain the scheme shown on the box. There are other schemes used on P-40s which would not require as much painting; however, most of these are not as attractive.

Here is a brief bibliography of some of the many books available that have useful P-40 information.

1. **Curtiss P-40 in Action**, Squadron/Signal Publication, Aircraft No. 26.

Good general P-40 information. Has many black and white photos and color illustrations of various P-40's. Very helpful.

2. **49th Fighter Group**, Squadron/Signal Publications, #6171

Lots of black and white photographs and lots of color illustrations of various P-40's. It also has wartime stories about flying P-40's. Very nice.

3. **The Pictorial History of the Flying Tigers**, Moss Publications, by Larry M. Pistole. A historical look at the Flying Tigers. Many decent (but old) black and white photos, mostly of "B" and "C" models. Some "E" model photos and a small number of color photos are also included. It is a very interesting book, but is not extremely useful for documentation purposes.

COLORS

These are the federal standard colors used by the Flying Tigers on their P-40's. They are available in Model Master Paints.

TAN FS30219
GREEN FS34102
GREY FS36622

FINISHING TECHNIQUES

There are many techniques to prepare the structure for painting. Probably the most durable finish is the "glassed" surface. "Glassing" the

wooden structure involves coating the wooden surfaces with a lightweight fiberglass cloth (usually 3/4 oz.) and a coating resin (epoxy or polyester). There are many articles on glassing aircraft and we will not go into this technique in detail.

The technique we will describe here is how the model pictured on the box was finished. In general, it involves covering the model with clear MonoKote covering, then priming and painting it.

PAINTED MONOKOTE FINISHING TECHNIQUE

Advantages and Disadvantages of the painted MonoKote finish compared to a glassed finish.

Advantages

1. Preparation for the MonoKote covering is familiar to most modelers.
2. The model will usually be lighter than a glassed model.
3. You will need to do less sanding compared to a glassed model. This saves time.

Disadvantages

1. You will need to MonoKote or seal difficult areas such as fillets.
2. The paint does not adhere quite as well as it does to fiberglass.

OVERVIEW OF THE PROCESS

1. Prepare and sand the structure.
2. Cover the structure with clear MonoKote.
3. Scuff up the MonoKote.
4. Prime the structure.
5. Sand the primer.
6. Paint the colors.
7. Clear coat (gloss) the aircraft.
8. Wet sand the clear coat .
9. Apply the decals and panel lines.
10. Apply the final clear coat (satin).

Description of Materials Used

Hobbico HobbyLite Filler - for filling dents and cracks and shaping fillets.

Clear Top Flite MonoKote Covering - for covering the structure. **NOTE:** the clear MonoKote sticks to the wood extremely well.

Top Flite LusterKote™ Primer - for filling minor imperfections and preparing the covering for painting.

Model Master Plastic Enamel colors - These paints are available in the proper federal standard colors to match the authentic Flying Tigers aircraft. These paints are not what you would consider fuel proof, so you must subsequently coat the aircraft with a fuel proof clear paint.

K & B Clear - the K & B paints are about the most fuel proof and durable paints available. They contain very strong solvents which will help blend-in overspray of the model master colors. Both gloss and satin hardeners are available for the K & B paints.

NOTE: The technique described here has been thoroughly tested on our prototype models. As with any paint system you have not used before, we highly recommend you paint a test piece using the exact system you will use on your model. No "reactions" were encountered using the materials described here, but if you substitute for any of them, you should test all of the materials on a test piece.

Tips for preventing paint peeling over MonoKote:

1. Stick the MonoKote to solid wood structures thoroughly with an iron equipped with a Top Flite Hot Sock™.
2. Scuff the MonoKote thoroughly with a Scotch Scuff Pad.
3. Clean the surface with Isopropyl Alcohol before priming.
4. Use very little primer, especially over open structures (elevators, etc.).
5. Use a high quality, low tack, vinyl based tape (available at auto painting stores) for masking. Use narrow tape and lots of non-adhesive paper when masking.
6. Always remove the tape by peeling it up **very slowly**. Pull the tape back over itself.

The finish obtained using this technique is of very high quality, and is very durable and chip resistant after the K & B Clear coat has been applied.

COVER THE STRUCTURE WITH MONOKOTE

Make sure the structure is smoothly sanded with 320 grit sandpaper. Remove all dust from the structure so the MonoKote will stick well.

Cover the aircraft with clear MonoKote using the sequence below. Make sure the MonoKote is thoroughly stuck down to the structure and all of the edges are sealed.

NOTE: When covering areas that involve fillets and sharp junctions, like the tail section of the P-40, cut narrow strips (3/8" to 5/8") and apply them in the corners before covering the major surfaces. The larger pieces of MonoKote will overlap and capture these smaller surfaces. This technique also bypasses the need to cut the MonoKote in these areas after it has been applied. DO NOT, under any circumstances, attempt to cut the covering material after it has been applied to the fin and stab, except around the leading and trailing edges and the tip. Modelers who do this often cut through the covering and part-way into the balsa stab skin. This can weaken the stab to the point where it may fail in flight!

Recommended Covering Sequence:

1. Tail Fillet Strips as described in the preceding note
2. Rudder left side
3. Rudder right side
4. Bottom of elevators
5. Top of elevators
6. Stab bottom
7. Stab top
8. Wing fillet (on fuselage)*
9. Fuse bottom
10. Fuse sides
11. Fuse top
12. Fin left side
13. Fin right side
14. Ends of ailerons and flaps
15. Bottom of ailerons and flaps
16. Top of ailerons and flaps
17. TE surfaces of wing (at ailerons and flaps)
18. Fuselage fairing (on bottom of wing)
19. Bottom of left wing panel
20. Bottom of right wing panel
21. Top of left wing panel (overlap covering 1/4" at wing LE)
22. Top of right wing panel (overlap covering 1/4" at the LE)

*When covering concave surfaces, follow the iron with a damp cloth, pressing the covering down.

APPLY THE PRIMER

Spray the entire aircraft with a thin coat of primer. Add a second coat of primer to areas that need it, such as seams in the MonoKote. Also apply primer to the plastic parts to prepare them for paint.

NOTE: Keep the primer very thin over open structures such as the elevators.

Sand the primer with 320 and 400 grit sandpaper using a block where possible. Most of the primer should be sanded off.

APPLY THE COLORS

We recommend gluing the hinges in and attaching all of the control surfaces **except** the flaps before proceeding. See the **Hinging** section on page 49.

NOTE: The Model Master colors are available in both spray cans and bottles. The use of bottled paint will be described here.

If you use Model Master colors, combine the small bottles of paint into a larger bottle and mix them thoroughly to make sure the color is uniform. The Model Master paints will need to be thinned some in order to spray well.

NOTE: The Model Master colors will flow out better and have less chalky overspray if you use a painting device which sprays a larger volume of paint (a touch up gun sprays more than an airbrush). Use a larger paint gun where possible, such as on the base colors.

Spray the **grey** parts of the aircraft first. The inside of the flaps and wheel wells may be painted grey with a brush. Wet sand any rough parts with 400 to 600 grit sandpaper.

Mask off the grey parts and apply the **tan** to the aircraft. Wet sand any rough places in the tan with 400 to 600 grit sandpaper.

Spray the **green** portions of the model. You may need to do some alternating passes of green and tan to get the scheme the way you want it.

HINT: Use a soft paper towel and circular Cycles to burnish off unwanted overspray. Use a Tack Rag to remove the remaining dust.

The K & B Clear will melt away much of the unevenness that will appear in the areas you touch up with green and tan. Apply isopropyl (rubbing) alcohol to the model with a paper towel to "preview" what it will look like when sprayed with clear.

APPLY A COAT OF CLEAR

Use a touch-up spray gun to coat the aircraft with a medium coat of clear. We recommend you use gloss hardener in K & B clear for this intermediate coat of clear because it will wet out better and the decals will apply more transparently over gloss clear than satin clear.

K & B paints are not difficult to use if you have spray equipment. Use equal parts of paint (A) and hardener (B), mix well, and thin. (Use K & B thinner that is about 30 to 40 percent of the volume of parts A and B combined.)

Wet sand the entire plane with 600 grit sandpaper. Touch up any colored areas that need adjusting and reapply clear over those areas.

APPLY THE DECALS

NOTE: The decal sheet does not give you everything you need to completely trim your model, but it does provide all the intricate detailing and difficult items.

- 1. Study the plans and the photos on the box to decide where to place the decals.
- 2. Thoroughly clean your airplane before applying decals.

- 3. Trim the decals as close as practical. Carefully apply the decals to the model.

NOTE: Certain decals are provided that you may use at your discretion.

The shark mouth decals are easy to apply as long as you are very careful. It may be necessary to cut relief slits in the decal in order for it to conform properly to the curves of the cowling. Apply the decals up to the seam of the cowl sides and cowl front and then paint the front to match the photo on the box.

DRAW THE PANEL LINES ON THE MODEL (OPTIONAL)

Inked-on panel lines are easy to draw, and enhance the model's appearance. For the most accurate results, refer to the Koku Fan 3-view drawing for placement of the lines. You may also use the pictures on the box for reference.

Mix black and white ink to obtain a medium grey colored ink. Normal ink for Rapidograph pens for use on mylar works fine. Load the ink into a .5 to .7mm technical drafting pen. Use a thin plastic ruler to guide the pen.

HINT: Apply a strip or two of masking tape to the bottom side of the ruler about 1/8" from the edge. The tape will add friction so the ruler won't slide, and will keep the ink from wicking under the ruler.

The ink will prevent you from cleaning the model with any solvents, so be careful not to get too many finger prints or oils on the surface.

FINAL CLEAR COAT

The model should have a satin or flat finish for best appearance. K & B clear with satin hardener was used on the prototypes with good results. It is very fuelproof and durable. Hobbypoxy clear is very similar and it is available with a true "flat" hardener.

Spray a light to medium coat of clear on all of the parts of the model.

EXHAUST STACKS

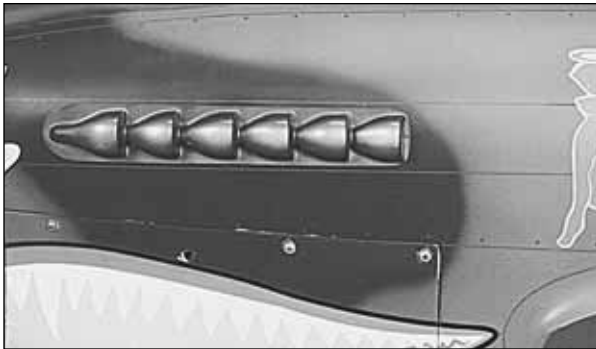

1. Trim the **Exhaust Stacks** as closely as you can.
2. Paint the exhaust stacks. Aluminum Chevron Perfect paint was used on the prototypes. You may "weather" them with some dark paint.
3. Mark the perimeter of the stacks on the fuselage. Use a pin to perforate the covering underneath the stacks.
4. Rough up the underside of the plastic stacks with sandpaper.
5. Glue on the stacks. CA glue was used on the prototypes.

HINGING

NOTE: *Hinging is usually done after covering and priming, but before color application. The hinge locations are shown on the plans.*

1. Cut 24 hinges (3/4" x 1") from the 2" x 9" CA hinge strip. Trim off the corners for easier insertion as shown in the sketch.

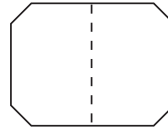

HINGE THE ELEVATOR

2. Test fit the elevators to the stabilizer with all of the hinges and the wire joiner in place. Make sure the elevators are both set at the same angle. Make adjustments if necessary.
3. Work a generous amount of 30-minute epoxy into the wire joiner holes in the elevators. Install the wire joiner and wipe away any excess epoxy.
4. Install the elevators onto the stab and glue the hinges in place using 4-6 drops of thin CA on each side of the hinge.

THERE SHOULD BE NO HINGE GAP

HINGE THE AILERONS AND RUDDER

5. Hinge the Ailerons and rudder using the same technique as the elevators, except, they do not have any wire torque rods, so they don't require any epoxy.
6. Flap hinge installation is covered in the Flap Fitting Section. On the prototypes, the flap hinges were epoxied in **after** the final clear coat was applied.

FINAL ENGINE INSTALLATION

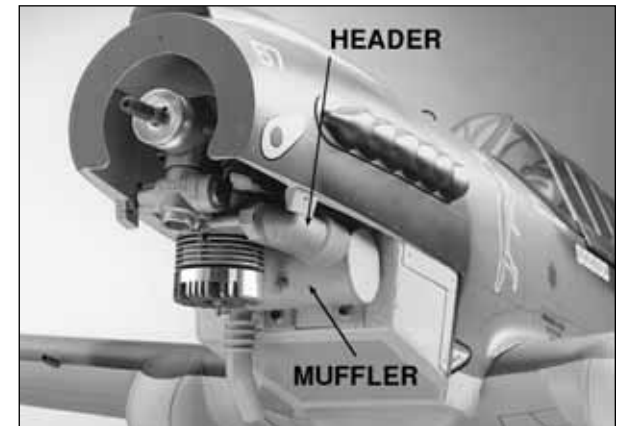

The above photo shows the installation of a O.S. .61SF along with Top Flite's custom muffler and header (See page 6 for part #'s). A remote glow plug adaptor, fueler valve, and air valve may be mounted as shown in the photo below. A Hobbico exhaust deflector (HCAP2175) can be used to divert the fumes out of the cowl.

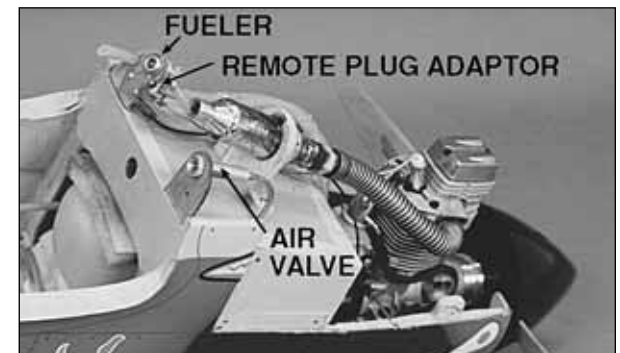

The above photo shows the installation of the O.S. 120 Surpass 4-Cycle along with a remote glow valve, fueler valve, and an air valve.

NOTE: If the flexible pipe is bent as shown in the photo, it will fail after minimal use. We recommend that you use the O.S. inside header (OSMG2622). (*This part was not available when this photo was taken.)

Here are a few options when using an O.S. 1.20 4-Cycle:

- A. Use the stock exhaust system and have it exit the left side of the cowing.
- B. Use the O.S. inside header and flexible extension (OSMG2682). The flexible extension can be used with or without the muffler attached.

FINAL CONTROL HARDWARE HOOKUP



- 1. Glue the 5/16" x 3/4" x 7/8" hardwood **Flap Servo Mounting Blocks** to the die-cut 1/6" plywood **Flap Servo Hatches**. Install the flap servos as shown in the above photo and on the plans.



- 2. Install the flap and aileron horns in line with the pushrod exits as shown on the plans. Drill 1/16" holes at the proper horn locations, then saturate the holes with CA glue. Screw the horns in place with #2 x 3/8" Sheet Metal Screws.



- 3. Hook up and adjust the aileron and flap linkages. Two .074 x 4" **Threaded End Rods** are provided to make the flap pushrods. The flap pushrods may be connected to the servos using Z-bends, or solder-on clevises (not included.) Refer to the **Control Surface Throws** section (page 51) for movement recommendations.

- 4. The **Rudder** is hooked up using a **Small Control Horn** (cut down to two holes) and a **Nylon Clevis**. Refer to the plans for the proper location. Mark the location of the horn and drill two 1/16" pilot holes part way through the rudder. Thoroughly saturate the holes with CA. Put a drop of CA on the back of the horn and screw the horn onto the rudder with two #2 x 3/8" **Sheet Metal Screws**.



- 5. The **retract switch valve**, tank, and servo installation can be seen in the photo above. Die-cut parts are supplied to mount the valve. The tank fits in the built-in cradle in formers F-3 and F-4, and it can be secured with two #2 x 3/8" screws and a rubber band (not supplied) or silicone glue/sealant.

- 6. Solder-on threaded couplers and nylon clevises are recommended for internal **elevator** and **rudder servo** hookups. Refer to the photos and plans for proper servo and horn orientation.

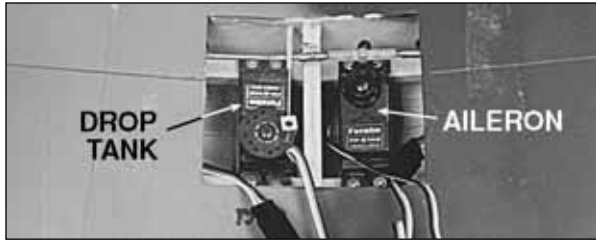

7. The **aileron** and optional **drop tank** servo hook-ups can be seen in the above photo. The aileron servo uses a **Two-ended ball link connector** and **Threaded Couplers**. You may want to relieve the notch in W-1 to allow for some extra clearance. The drop tank release system uses a quick connector to hook the release cable to the servo.

8. A **throttle** linkage is not included, but a plastic pushrod (GPMQ3714) such as the one shown in the previous steps works well for most installations.

COCKPIT FINISHING (Basic cockpit)

1. Sand the inside of the cockpit around the edges with 320 grit sandpaper. True up any uneven edges in the cockpit area.

2. Test fit the pilot into the model. Our Williams Brothers scale pilot required a 3/8" block under him to adjust his height. Assemble and paint your pilot.

3. You may make a head rest from scrap balsa like the one shown in the in the photos.

4. Paint the interior of the cockpit. An alternative to paint is to cover the inside of the cockpit with a fine grit black sandpaper for a textured finish. If you use the sandpaper technique, it is still advisable to paint the cockpit corners black first.

5. Install the **instrument panel decal**. It may be applied directly to the existing panel. **Hint:** For best results, stick the decal to a scrap piece of 1/64" to 1/16" plywood, trim it to shape, then glue it in place.



6. Check the fit of the canopy to the fuselage. Trim the canopy to the proper line. Glue a strip of 3/32" balsa to the inside of the canopy where shown. Sand the strip down until it contacts the fuselage when the remainder of the canopy has a nice relaxed fit.



7. Paint the frame of the canopy. This can be done from the inside or the outside; the choice is yours. The prototype was painted on the outside, since the glue seems to stick better if the inside is roughed up with sandpaper and unpainted. Painting the frame from the outside also allows you to obtain a flat finish. **HINT:** "Frisk Film" which is available at art supply stores is excellent for masking off the window panes. It can be cut (carefully) right on the canopy with a sharp #11 blade.

8. Glue the canopy to the model. We recommend using RC-56 glue or 6-minute Epoxy to glue on the canopy, but if you have a favorite technique, use it. You should remove a small strip of MonoKote (if applicable) from under the frame for good glue adhesion. Use masking tape to hold the canopy in place while the glue sets.

CONTROL SURFACE THROWS:

We recommend the following control surface throws:

NOTE: Throws are measured at the **widest part** of the elevators, rudder, ailerons and flaps.

ELEVATOR:

(High Rate)	11/16" up	11/16" down
(Low Rate)	9/16" up	9/16" down

RUDDER:

(High Rate)	1-1/2" right	1-1/2" left
(Low Rate)	1-1/4" right	1-1/4" left

AILERONS:

(High Rate)	5/8" up	5/8" down
(Low Rate)	1/2" up	1/2" down

FLAPS:

(Full Down)	1-1/2" down
-------------	-------------

NOTE: If your radio does not have "dual rates," then set up the control surfaces to move at or slightly less than **high rate** throws.

NOTE: *The balance and surface throws for this aircraft have been extensively tested. We are confident that they*

represent the settings at which the P-40 flies best. Please set up your aircraft to the specifications listed above. If, after a few flights, you would like to adjust the throws to suit your tastes, that is fine. Most warbirds such as the P-40 have large elevators and do not require much throw. Too much throw can force the plane into a stall, so remember... "More is not better."

INSTALL RECEIVER, SWITCH AND BATTERY

- 1. Wrap your receiver and battery in plastic bags, then wrap with foam rubber.

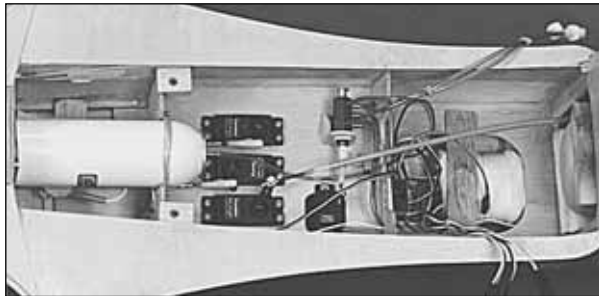

- 2. Install the **battery** and **receiver** in the fuselage. **NOTE:** The receiver was put through the lightening hole in the crutch between formers F-3 and F-4. The battery position should be selected to balance the aircraft.

- 3. Route the receiver **antenna** in one of the following ways:

- A. Route the antenna along the inside of the fuselage side and out of the fuselage top, just behind the canopy. Anchor the antenna to the top of the fin with a rubber band.

- B. Insert the antenna into a "pushrod guide tube" (not included) and tape it securely at the aft end. Install the tube and antenna into the aft portion of the fuselage through the lightening holes in the fuselage formers. The entire length of the antenna should be extended relatively straight.

BALANCE YOUR MODEL

NOTE: This section is VERY important and must not be omitted! A model that is not properly balanced will be unstable and possibly unflyable.

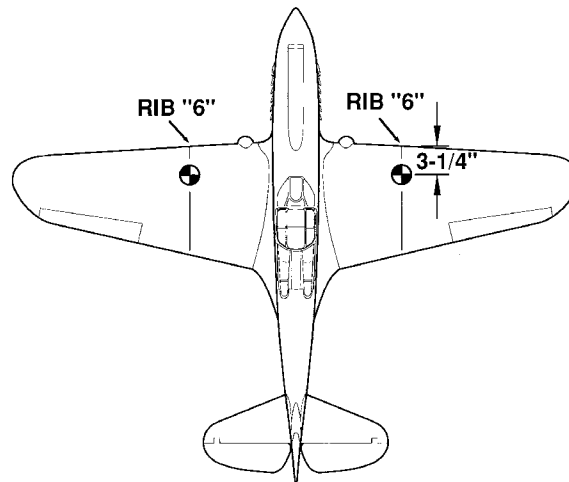

- 1. Accurately mark the balance point on the **top** of the wing on both sides of the fuselage. The balance point is shown on the plan (**CG**), and is located **3-1/4 inches** back from the leading edge at the location of rib #6 as shown in the sketch and

on the plans. Hint: Use the full-sized wing plan to help you accurately locate the proper **CG** on the wing. This is the balance point at which your model should balance for your first flights. Later, you may wish to experiment by shifting the balance up to **1/4" forward or back** to change the flying characteristics. Moving the balance **forward** may improve the smoothness and arrow-like tracking, but it may then require more speed for takeoff and make it more difficult to slow down for landing. Moving the balance **aft** makes the model more agile with a lighter and snappier "feel" and often improves knife-edge capabilities. In any case, **please start at the location we recommend and do not at any time balance your model outside the recommended range.**

- 2. With the wing attached to the fuselage, all parts of the model installed (ready to fly), an **empty** fuel tank, and the landing gear down (extended), hold the model upside down with the stabilizer level.

- 3. Lift the model at the CG marks. If the tail drops when you lift, the model is "tail heavy" and you must add weight* to the nose to balance. If the nose drops, it is "nose heavy" and you must add weight* to the tail to balance. **NOTE:** Nose weight may be easily added by gluing strips of lead into the engine compartment. Tail weight may be added by using Great Planes (GPMQ4485) "stick-on" lead weights, and, later, if the balance proves to be OK you can open the fuse bottom and glue these in permanently.

*If possible, first attempt to balance the model by changing the position of the receiver battery and receiver. If you are unable to obtain good balance by doing so, **then** it will be necessary to add weight to the nose or tail to achieve the proper balance point.

FINAL HOOKUPS AND CHECKS

- ❑ 1. Make sure the control surfaces move in the proper direction as illustrated in the following diagram.

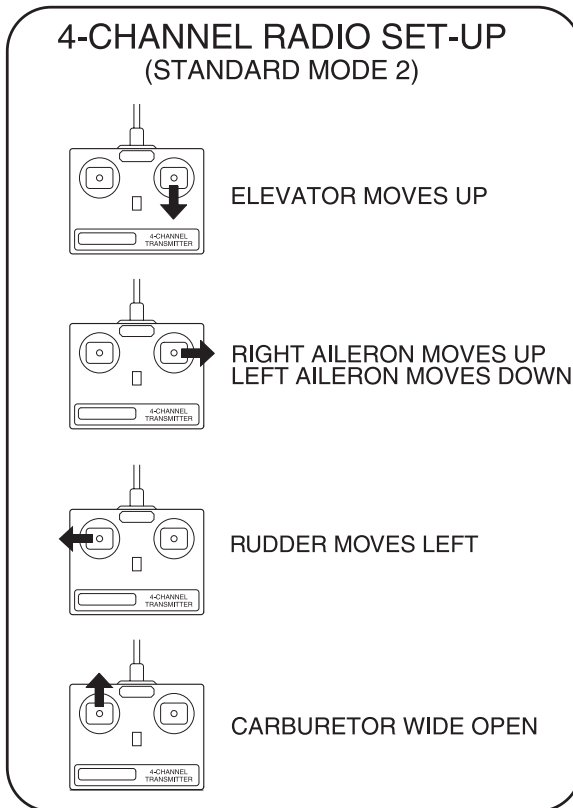

- ❑ 2. Adjust your pushrod hookups as necessary to provide the proper control surface movements as listed on Page 52.

***NOTE:** These control surface “throws” are thoroughly tested and provide the

best starting point for the first flights with your P-40. After initial testing, you may wish to change the throws slightly to provide the smoothness or quickness that you prefer.

PRE-FLIGHT

CHARGE THE BATTERIES

Follow the battery charging procedures in your radio instruction manual. You should **always** charge your transmitter and receiver batteries the night before you go flying, and at other times as recommended by the radio manufacturer.

BALANCE THE PROP

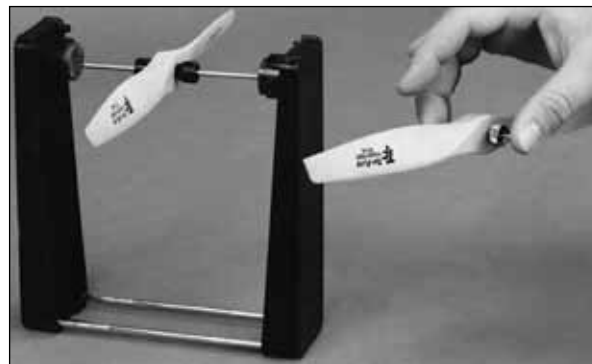

A properly balanced prop is a must for top engine performance. This can be easily done by using the Top Flite Power Point® Magnetic Prop Balancer™. This precision balancing device is incredibly accurate and perfect for precision balancing most styles of props and accessories.

FIND A SAFE PLACE TO FLY

1. The best place to fly your R/C model is an AMA (Academy of Model Aeronautics) chartered club field. Ask your hobby shop dealer if there is such a club in your area and join. Club fields are set up for R/C flying and that makes your outing safer and more enjoyable. The AMA also can tell you the name of a club in your area. We recommend that you join AMA and a local club so you can have a safe place to fly and have insurance to cover you in case of a flying accident. (The AMA address is listed on the page 3 of this instruction book). If a club is not available, you need to find a large, grassy area at least 6 miles away from any other R/C radio operation like R/C boats and R/C cars and away from houses, buildings and streets. A schoolyard may look inviting but it is too close to people, power lines and possible radio interference.

Please note: This is not a beginner's model; therefore, if you are not an experienced, competent R/C pilot, you must seek out a qualified instructor and learn to fly well before attempting to fly this model.

GROUND CHECK THE MODEL

If you are not thoroughly familiar with the operation of R/C models, ask an experienced modeler to check to see that you have the radio installed correctly and that all the control surfaces do what they are supposed to. The engine operation also must be checked and the engine “broken-in” on the ground by running the engine for at least two tanks of fuel. **Follow the engine manufacturer's recommendations for break-in.** Do not attempt to fly the model until you have the engine running reliably at all throttle settings and delivering full power. Check to make sure all screws remain tight, that the hinges are secure and that the prop is on tight.

RANGE CHECK YOUR RADIO

Wherever you do fly, you need to check the operation of the radio before every time you fly. This means with the transmitter antenna collapsed and the receiver and transmitter on, you should be able to walk at least 100 feet away from the model and still have control. Have someone help you. Have them stand by your model and, while you work the controls, tell you what the various control surfaces are doing.

Repeat this test **with the engine running** at various speeds with an assistant holding the model. If the control surfaces are not always acting correctly, **do not fly!** Find and correct the problem first.

ENGINE SAFETY PRECAUTIONS

NOTE: *Failure to follow these safety precautions may result in severe injury to yourself and others.*

Keep all engine fuel in a safe place, away from high heat, sparks or flames, as fuel is very flammable. Do not smoke near the engine or fuel; and remember that the engine exhaust gives off a great deal of deadly carbon monoxide. Therefore **do not run the engine in a closed room or garage.**

Get help from an experienced pilot when learning to operate engines.

Use safety glasses when starting or running engines.

Do not run the engine in an area of loose gravel or sand as the propeller may throw such material in your face or eyes.

Keep your face and body, and all spectators away from the plane of rotation of the propeller as you start and run the engine.

Keep items such as these away from the prop: loose clothing, shirt sleeves, ties, scarfs, long hair

or loose objects (pencils, screw drivers) that may fall out of shirt or jacket pockets into the prop.

Use a "chicken stick" device or electric starter; follow instructions supplied with the starter or stick. Make certain the glow plug clip or connector is secure so that it will not pop off or otherwise get into the running propeller.

Make all engine adjustments from **behind** the rotating propeller.

The engine gets hot! Do not touch it during or after operation. Make sure fuel lines are in good condition so fuel is not leaked onto a hot engine causing a fire.

To stop the engine, cut off the fuel supply by closing off the fuel line or follow the engine manufacturer's recommendations. Do not use hands, fingers or any body part to try to stop the engine. Do not throw anything into the prop of a running engine.

AMA SAFETY CODE

Read and abide by the following Academy of Model Aeronautics Official Safety Code:

GENERAL

1. I will not fly my model aircraft in competition or in the presence of spectators until it has been proven to be airworthy by having been previously successfully flight tested.

2. I will not fly my model aircraft higher than approximately 400 feet within 3 miles of an airport without notifying the airport operator. I will give right of way to, and avoid flying in the proximity of, full scale aircraft. Where necessary an observer shall be used to supervise flying to avoid having models fly in the proximity of full scale aircraft.

3. Where established, I will abide by the safety rules for the flying site I use, and I will not willfully and deliberately fly my models in a careless, reckless and/or dangerous manner.

RADIO CONTROL

1. I will have completed a successful radio equipment ground check before the first flight of a new or repaired model.

2. I will not fly my model aircraft in the presence of spectators until I become a qualified flyer, unless assisted by an experienced helper.

3. I will perform my initial turn after takeoff away from the pit, spectator and parking areas, and I will not thereafter perform maneuvers, flights of any sort or landing approaches over a pit, spectator or parking area.

FLYING

The Top Flite P-40E is a great flying sport scale airplane that flies smoothly and predictably, yet is highly maneuverable. It does **not** have the self-recovery characteristics of a primary trainer. Therefore you must either have mastered the basics of R/C flying or seek the assistance of a competent R/C pilot to help you with your first flights.

TAKEOFF: If you have dual rates on your transmitter, set the switches to "high rate" for takeoff, especially when taking off in a cross wind. We recommend that you **do not** use flaps for the takeoff. Although this P-40 has good low speed characteristics, you should always build up as much speed as your runway will permit before lifting off, as this will give you a safety margin in

case of a “flame-out.” When you first advance the throttle and the tail begins to lift, the plane will start to turn left (a characteristic of all “tail draggers.”) Be ready for this, and correct by applying sufficient right rudder to hold it straight down the runway. The left-turning tendency will go away as soon as the tail is up and the plane picks up speed. Be **sure** to allow the tail to come up. Depending on the surface you are flying off of, you will need to apply very little to no up elevator until flying speed is obtained. CAUTION: holding the tail on the ground with too much up elevator will cause the Warhawk to become airborne prematurely at an angle of attack at which the wing is stalled.

When the plane has sufficient flying speed, lift off by smoothly applying up elevator (don’t “jerk” it off to a vertical climb!), and climb out gradually.

FLYING: We recommend that you take it easy with your Warhawk for the first several flights and gradually “get acquainted” with this realistic warbird as your engine gets fully broken-in. Add and practice one maneuver at a time, learning how she behaves in each. For ultra-smooth flying and normal maneuvers, we recommend using the “low rate” settings as listed on page 51. “High rate” elevator may be required for crisp snap rolls and spins. “High rate” rudder is best for knife edge.

LANDING: When it’s time to land, fly a normal landing pattern and approach. The Warhawk will probably bleed off airspeed more rapidly than the sport planes you are used to. For this reason, keep a few clicks of power on until you are over the runway threshold. For your first landings, plan to land slightly faster than stall speed and on the main wheels, as this is the easiest way to land your Warhawk. Later, with a little technique, you will find you can make slow, 3-point landings.

If you have flaps, lower them on the downwind leg of your approach. Full flaps make the P-40

very steady in the landing pattern. Just carry a little extra power to make up for the extra drag. The extra drag of the flaps also allows you to make shorter, steeper approaches. Touch-and-go’s and go-arounds can be accomplished with full flaps, but be ready to use a little more up elevator. It is **preferred** to have the flaps raised for takeoffs and climb outs because the plane will accelerate and climb better. If you have to go around, and your flaps are lowered, it is better to gain some altitude and airspeed before raising the flaps.

CAUTION

(THIS APPLIES TO ALL R/C AIRPLANES):

If, while flying, you notice any unusual sounds, such as a low-pitched “buzz,” this may be an indication of control surface “flutter.” Because flutter can quickly destroy components of your airplane, any time you detect flutter you must immediately cut the throttle and land the airplane! Check all servo grommets for deterioration (this will indicate which surface fluttered), and make sure all pushrod linkages are slop-free. If it fluttered once, it probably will flutter again under similar circumstances unless you can eliminate the slop or flexing in the linkages. Here are some things which can result in flutter: Excessive hinge gap; not mounting control horns solidly; sloppy fit of clevis pin in horn; elasticity present in flexible plastic pushrods; side-play of pushrod in guide tube caused by tight bends; sloppy fit of Z-bend in servo arm; insufficient glue used when gluing in the elevator joiner wire or aileron torque rod; excessive flexing of aileron, caused by using too soft balsa aileron; excessive “play” or “backlash” in servo gears; and insecure servo mounting.

Have a ball! But always stay in control and fly in a safe manner.

GOOD LUCK AND GREAT FLYING!

If you enjoyed building the Top Flite P-40E, try one of these other Gold Edition kits as your next project.



(TOPA0110) Top Flite P-51D Mustang



(TOPA0101) Top Flite F4U Corsair

TWO-VIEW DRAWING

Use this layout for trim
scheme planning only.
Not suitable for scale
documentation.

