

TEN SCITE





Notice

All instructions, warranties and other collateral documents are subject to change at the sole discretion of Horizon Hobby, Inc. For up-to-date product literature, visit www.horizonhobby.com and click on the support tab for this product.

Meaning of Special Language

The following terms are used throughout the product literature to indicate various levels of potential harm when operating this product:

NOTICE: Procedures, which if not properly followed, create a possibility of physical property damage AND a little or no possibility of injury.

CAUTION: Procedures, which if not properly followed, create the probability of physical property damage AND a possibility of serious injury.

WARNING: Procedures, which if not properly followed, create the probability of property damage, collateral damage, and serious injury OR create a high probability of superficial injury.



WARNING: Read the ENTIRE instruction manual to become familiar with the features of the product before operating. Failure to operate the product correctly can result in damage to the product, personal property and cause serious injury.

This is a sophisticated hobby product and NOT a toy. It must be operated with caution and common sense and requires some basic mechanical ability. Failure to operate this Product in a safe and responsible manner could result in injury or damage to the product or other property. This product is not intended for use by children without direct adult supervision. Do not attempt disassembly, use with incompatible components or augment product in any way without the approval of Horizon Hobby, Inc. This manual contains instructions for safety, operation and maintenance. It is essential to read and follow all the instructions and warnings in the manual, prior to assembly, setup or use, in order to operate correctly and avoid damage or serious injury.

Introduction

Thank you for choosing the TEN-SCTE. We are confident you will be satisfied with the performance of this durable and resilient vehicle. Please read through the entire manual before setting up and using your vehicle.

Register your Losi® Product Online

Register your TEN-SCTE now and be the first to find out about the latest options parts, product updates and more. Log on to www.LOSI.com and follow the product registration link to stay connected.

Getting Ready

Thoroughly read all the enclosed material, precautions and follow instructions to avoid damaging your new RC vehicle. If you choose to not follow these steps or instructions, it will be considered negligence. If after review of this manual and prior to running your TEN-SCTE, you determine this RC vehicle is not what you want—Do Not proceed and Do Not run the TEN-SCTE. If the TEN-SCTE has been run, your local hobby store will not be able to process a return or accept it for exchange.

Safety Precautions and Guidelines

Age Recommendation: Not for children under 14 years. This is not a toy.

Always operate this RC model in a safe, reasonable and cautious fashion. When driving the TEN-SCTE avoid someone being hit by the vehicle. You may cause serious injury to another person, or to personal property should you make contact while running the TEN-SCTE.

General

- This RC Vehicle is not intended for use on public highways or roads.
- Avoid areas that have many pedestrians or crowds of people.
- Keep in mind that this vehicle is radio controlled and can experience moments of radio loss or interference, provide for a margin of error at all times.
- Be aware that the motor and batteries of this RC vehicle will get HOT during each use. Be careful not to burn yourself.

Batteries and Charging

The TEN-SCTE uses rechargeable batteries such as NiMH. These batteries all have special requirements to preserve performance and last.

- Read all instructions provided by the manufacturer of the batteries.
- Never allow minors to charge battery packs.
- Always check to ensure the polarity of battery connection is correct.
- Never leave batteries unattended while charging.
- Never charge a battery while it is installed in the TEN-SCTE.
- Do not charge any battery that appears to have any damage.
- If there are exposed wires, do not charge or use the battery until you install shrink-wrap or replace the complete wire.

When charging NiMH batteries, select a charger to meet your requirements. You need a charger that is a 100-240V wall charger or one which requires a 12V power supply. Follow the charger manufacturer's instructions and precautions during each use.

Quick Start

Note: Please read the entire manual to gain a full understanding of the TEN-SCTE vehicle, fine-tuning the setup and performing maintenance.

1. Read the safety precautions found on this page.
2. Charge the battery pack you have chosen (NOT INCLUDED). Refer to the Manufacturer's Supplied instructions for battery charging information.
3. Install the AA batteries into the Transmitter. Use alkaline or rechargeable batteries only.
4. Install a fully charged battery pack.
5. Turn on the transmitter and then the vehicle. Always turn the transmitter on before the vehicle and turn it off after the vehicle has been turned off.
6. Check steering. Verify that the servo is functioning properly.
7. Driving the TEN-SCTE.
8. Performing maintenance of the TEN-SCTE.

Peak Detection Charger

Peak detection chargers monitor the battery during charging and automatically shut off upon full charge. You can either purchase a peak detection charger that plugs into a household AC wall socket or one that requires you to also purchase a 12V power supply.

If using a charger other than a peak detection charger, make sure your battery is fully discharged prior to charging. Many of these have a 15–20 minute timer that allows you to set a charge time. If the battery is not fully discharged, you can potentially over-charge your battery pack. Do not charge any battery unattended, and monitor for heat build up. If the battery pack is more than warm to the touch, immediately discontinue charging. Read all safety precautions supplied by the charger and battery manufacturer.

Supplied and Required Equipment

Supplied tools:



Wheel Wrench

Four (4) Hex "L" Wrench Set

.050-inch, 1/16-inch, 5/64-inch, and 3/32-inch

Shock Bottom wrench

Turnbuckle/Shock Top wrench



The Losi TEN-SCTE Overview

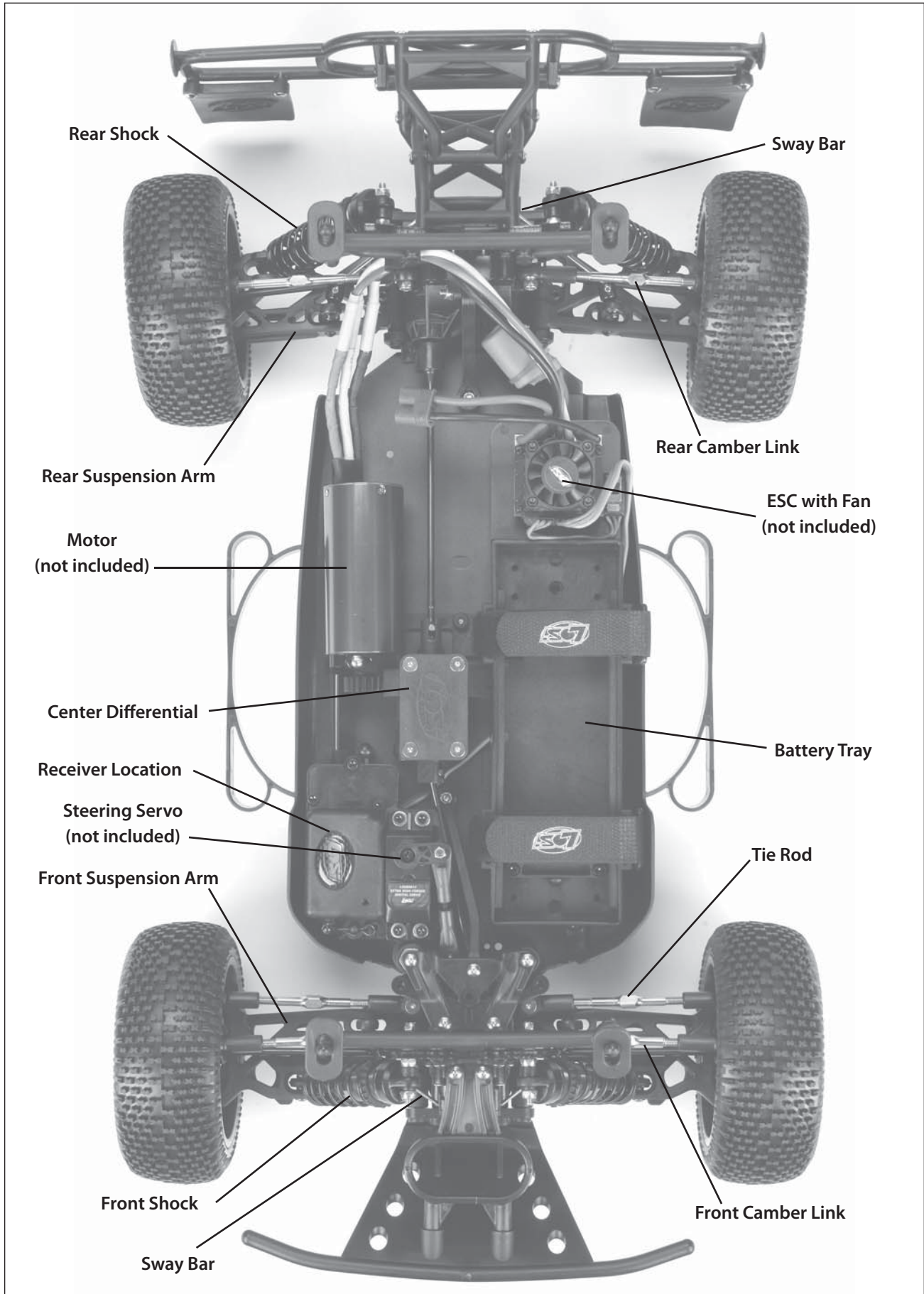

Tools You Will Find Handy



In addition to the tools included with the TEN-SCTE, you will find the following both useful and in some cases necessary.

- Small flat blade and Phillips screwdrivers
- Needle-nose pliers
- Quality .050-inch, 1/16-inch, 5/64-inch, 3/32-inch, 1.5mm and 2.5mm hex (Allen) drivers

Required Equipment:

Electronic Speed Control - We recommend the Xcelorin® Sensored Brushless Speed Control

Motor - Any 550-sized motor

Battery - We recommend the Xcelorin 7.4V 60C 2S 6000mAh LiPo (LOS9877)

Charger - We recommend the Xcelorin MultiPro™ Intelligent LiPo Balancing Charger (LOS9606)

Servo - Preferably Spektrum™ S6040

Pinion Gear - Any Mod 1 Pinion Gear

Note: We recommend a Losi LOSA3576 16T pinion gear for 4.5T 550 can motor, or a Losi LOSA3577 17T pinion gear for 5.5T 550 can motor.

Two Channel Radio - We recommend a Spektrum DX3R or DX3S transmitter and matching receiver.

Paint (always test the paint on material removed from the body to make sure the paint and body material are compatible.)

Basic Electronics Installation Instructions



Caution: Please be sure to follow the electronics manufacturers guidelines when installing and setting up your radio, motor, servo, electronic speed control, and battery.

Motor Installation: Follow diagram below

1. Install motor adapter onto motor with two supplied M3x10mm screws.
2. Install pinion gear (recommendations supplied earlier).
3. Slide motor with adapter into motor mount, set mesh, and tighten using 5-40 x 3/8 button head screw. Be sure to use threadlock.

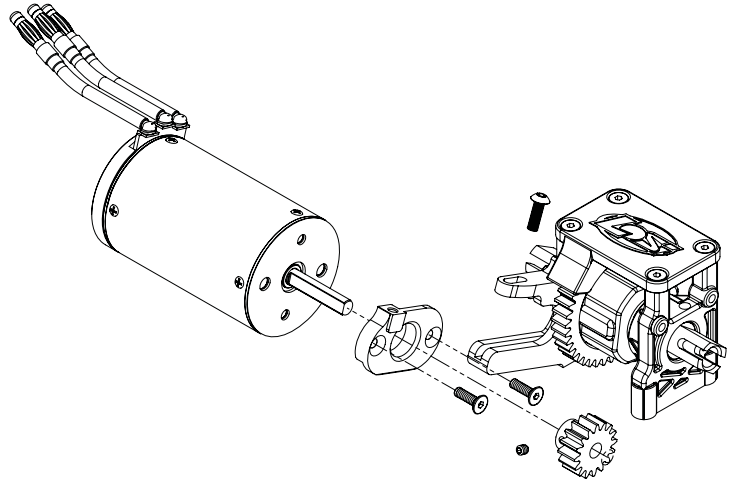

Receiver and Electronic Speed Control Installation:

Install with double-sided tape. Be sure to route wires so they will not get caught in the spur gear.

Servo Installation: (use following diagrams)

1. Install servo as shown in diagram using the four supplied 4-40 x 1/2 in screws and washers. Please look at supplied chart to determine if spacers are needed.
2. Choose correct servo horn adapter using servo horn chart and press onto servo.
3. After servo is centered, install servo horn on servo using the screw provided with your servo so that in the centered position the servo horn is parallel to the servo saver arm.

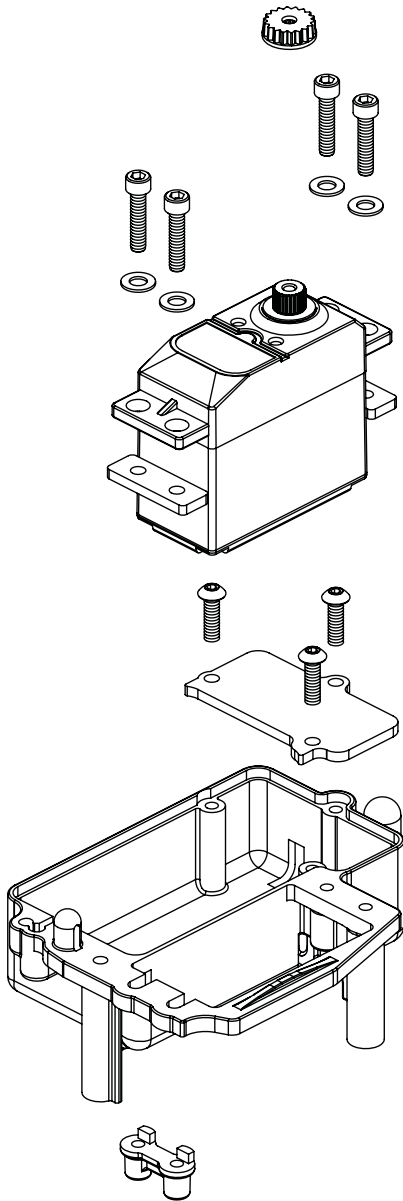

Before Running Your TEN-SCTE

1. Break in the differentials. While holding the chassis with only the left side tires firmly on the ground, give the car about one eighth throttle, for 30 seconds. The right side tires should spin freely during this time. Repeat this with only the right side tires firmly on the ground, allowing the left side tires to spin freely. Repeat this 2-3 times.
2. Check for free suspension movement. All suspension arms and steering components should move freely. Any binds will cause the car to handle poorly.
3. Set the ride height. Set the ride height of your truck with all components installed so that the bottom of the chassis is 29.5mm from the ground in the front and 24.5mm in the rear by adjusting the shock collars.
4. Set the camber. Adjusting the camber tie rod length changes the camber. Set the front tires to have 0 degrees of camber at ride height. Set the rear tires to have 2.5 degrees of negative camber at ride height.
5. Set the front toe-in. Adjust the steering tie rods so that when the servo is centered on the transmitter, the front tires are both pointing straight.
6. Charge a battery pack. Charge a battery pack as per the battery manufacturers and/or charger manufacturers' instructions.
7. Adjust the electronic speed control. Follow the manufacturers instructions to setup and adjust the speed control for your TEN-SCTE.
8. Set the transmitter steering trim. Follow the manufacturers instructions to set the steering trim/subtrim so that the vehicle goes straight with no input to the steering.
9. Set the transmitter steering endpoints. Follow the manufacturers' instructions to set the endpoints so that the servo hits full steering upon reaching full input from the transmitter.

Driving the TEN-SCTE

Always follow these precautions when running your TEN-SCTE.

Do not run the TEN-SCTE at dusk or in the dark when visibility is limited.

Do not attempt to run this model if it will be out of sight for any amount of time.

Do not run this model near a crowd of people.

Always check for proper radio function and battery condition before operating.

Check to make sure the tires are securely glued to the rims.

Check the model thoroughly for loose nuts, bolts and screws before and after running.

Make sure you use proper dirt tires if running off-road.

Never run the model with old or discharged batteries.

Leave plenty of room to stop the model. It will take as much room to stop as it did to accelerate.

Servo Manufacturer, Make/Model		Servo Spacer	Servo Horn
JR	All (DZ9100T/S Needs Spacer)	No	23T
Airtronics Sanwa	94357Z, 94358Z, 94649Z, 94360Z, 94452Z, 94758Z, 94737Z, 94738Z	Yes	23T
	94102Z, 94112Z	Yes	
Hitec	All	No	24T
Futaba	All (S9102 DOES NOT FIT)	No	25T
KO PROPO	PDS-2123, 2344, 2363, 2365, 2366	No	23T
		No	

Tuning, Adjusting and Maintaining the TEN-SCTE

Periodically examine your TEN-SCTE for the following:

- Keep your vehicle clean using a brush to remove dirt and dust.
- Look for cracks in the suspension arms and other molded parts.
- Check that the tires are still glued to the wheels.
- Check that all the wheel bearings are clean and lubricated.
- Using your tools, attempt to tighten all the screws and nuts.
- Verify that the Camber Links and Steering linkage are not bent.
- Check that the Toe and Camber settings are as desired and equal.
- Check the Drivetrain:
 - Check the Spur gear for wear.
 - Check the Pinion gear.
- Take the shocks off the vehicle and check, especially if they appear to be leaking as it is time to rebuild them.
- Look over all the wiring and connections for bare wire or any place which could lead to a short circuit.

After you become familiar with driving your TEN-SCTE, you may need to reset or make adjustments for better driving performance.

Just as in a real car, alignment is an important factor in your vehicle's handling. When you are ready to make adjustments it is a good idea to have a flat work space to place your vehicle on. This will enable you to easily and more quickly make both Toe-in and Camber adjustments. These adjustments should be set with the vehicle sitting at its normal ride height.

Three-Position Battery Tray: Your TEN-SCTE comes with a three-position battery tray to alleviate the need for foam blocks. You can move the included battery stops in order to run the battery in a back, middle, or forward position. Please see pictures as follows.

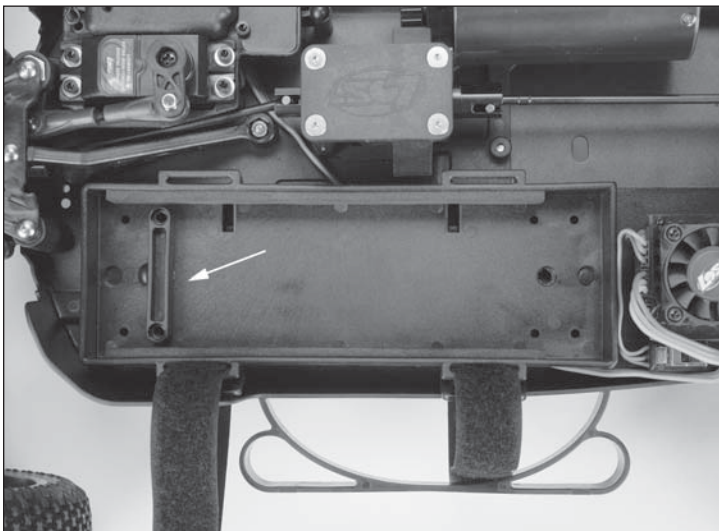

BACK

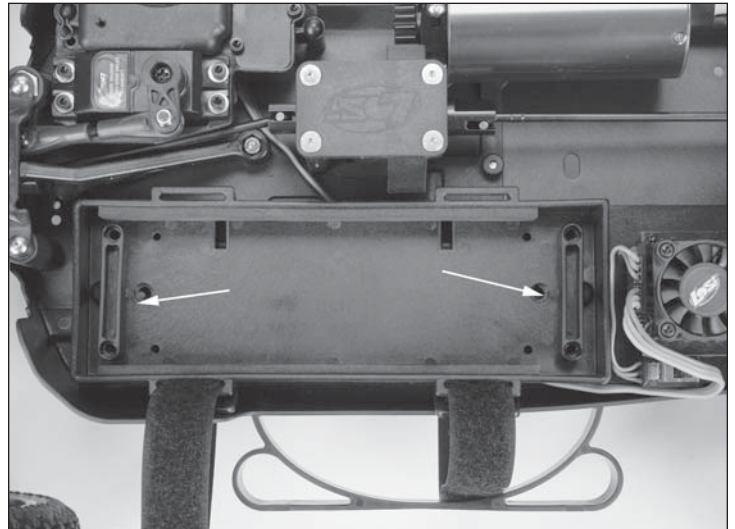

MIDDLE

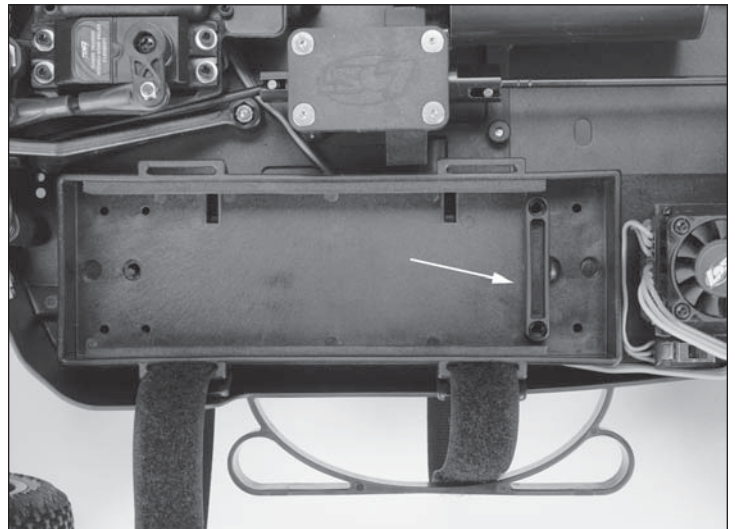

FORWARD



Maintenance

In addition to the service needs pointed out in this guide, you should try to maintain your new TEN-SCTE for proper performance and to prevent wear. If dirt gets in the moving parts it can seriously hinder the performance of the model. Use compressed air, a soft paintbrush and/or a toothbrush to remove dirt and dust. Avoid using solvents, if possible, as this can actually wash the dirt into bearings and areas not accessible without disassembly, causing additional wear. We suggest you follow these basic guidelines.

- Remove as much freestanding dirt and dust as noted above.
- Never leave the battery plugged in while vehicle is not running.
- Inspect the chassis for worn, broken or binding parts and repair as necessary.

Maintaining Differentials:

1. Remove differential from vehicle using exploded view.
2. Clean loose dirt off using brush.
3. Open differential as shown in diagram.
4. Clean out internals using motor spray.
5. Fill with oil to your liking and reverse steps to reinstall.

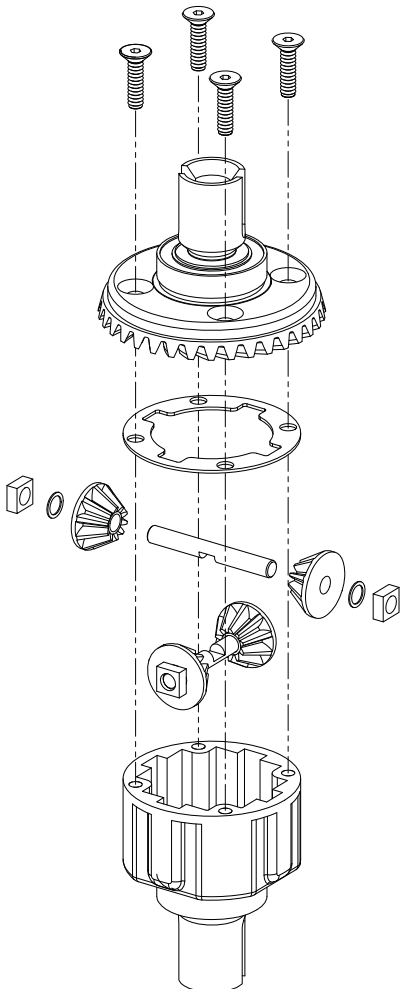

Tuning the Front End of the TEN-SCTE

Shock Location: The TEN-SCTE has three mounting locations on the front shock tower. The position can be easily adjusted by simply moving the top of the shock to another hole. The standard location works best on most surfaces. Moving the top of the shock inward a hole will slow steering response and make the TEN-SCTE smoother in bumps. The standard position on the arm is middle, which offers the best balance. Running the inside shock location will give the TEN-SCTE more steering into the turn and less steering on corner exit. Running the shock location outside on the front arm will give you less overall steering into the turn and keep the front end flatter through the turn, making the TEN-SCTE smoother and easier to drive. This can be used on high-traction surfaces. Keep in mind as you move the shocks in on the arm this will require internal limiters to obtain the correct suspension travel. For the inside location a total of .200-inch limiter works great. Losi sells a shock spacer set (LOSA5050) that includes .030-inch, .060-inch, .090-inch and .120-inch spacers.

All of the Camber and Steering linkages feature left and right-hand threads at either end like a turnbuckle to make adjustments easy. The side with right-hand threads has a small groove machined into it. Use the plastic turnbuckle wrench supplied with the TEN-SCTE to adjust these. Using the right-hand threaded side as your reference: if you turn the link to the right (clockwise) you will make it shorter. If you turn it to the left (counterclockwise) you will make it longer. If you will be making a lot of adjustments-you should consider using the LOSA99165 Aluminum Turnbuckle Wrench.

Static Camber: This refers to the angle of the wheels/tires relative to the surface (viewed from either the front or back). Negative camber means that the top of the tire leans in toward the chassis. Positive camber means the top of the tire leans out, away from the chassis. Camber can be precisely measured with after-market camber gauges, sold at a local hobby shop. It can be measured (roughly) using any square (to the ground) object by checking the gap between the square edge and the top of the tire. Testing has shown that 1 degree of negative camber is best for most track conditions. Increasing negative camber (in the range of 1-2 degrees) will generally increase steering. Decreasing negative camber (in the range of 0-1 degree) will generally decrease steering and the TEN-SCTE will feel easier to drive as a result. This is, most often, a very critical adjustment in tuning your TEN-SCTE that can be made quickly and easily.

Inboard Camber Location: The TEN-SCTE has two different inner locations with vertical adjustment for the front camber tie rod. In general, the lower or further out the inside position is, relative to the outside, the more camber gain (total camber change through the total throw of the suspension) is present. This is an adjustment that is difficult to make a generic statement as it can have slightly different results in various conditions. The following is a summary of how this adjustment will usually impact the handling of the TEN-SCTE. A longer front camber link will usually make the TEN-SCTE feel stiffer. This will help keep the TEN-SCTE flatter with less roll, but can make the TEN-SCTE handle worse in bumpy conditions. It also will make the TEN-SCTE easier to drive. A shorter front camber link will result in more front end roll, which will provide more steering on tighter turns with the loss of some stability. You will also lose some high-speed steering but might gain some more steering response. Too short of a front link may make the TEN-SCTE feel "twitchy" or "wandery" meaning that it may be difficult to drive straight at high speed.

Toe-In/Out: This is the parallel relationship of the front tires to one another. Toe-in/out adjustments are made by changing the overall length of the steering tie rods. Toe-in (the front of the tires point inward, to a point in front of the front axle) will make the TEN-SCTE react a little slower, but have more steering from the middle of the turn, out. The opposite is true with toe-out (the front of the tires point outward, coming to a point behind the front axle), the TEN-SCTE will turn into the corner better but with a decrease in steering from the middle of the turn, out. Toe-in will help the TEN-SCTE to "track" better on long straight high-speed runs, where toe-out has a tendency to make the TEN-SCTE wander. We recommend to run between 0-degree of toe-in/out to 1 degree of toe-in.

Differentials: The TEN-SCTE comes equipped with grease in all three differentials. You can switch to oil. Thinner front oil increases off-power steering, but if the oil is too thin the steering will become grabby and inconsistent. Thicker front differential oil increases off-power stability and increases on-power steering. Thinner center differential has less forward drive, can unload more under acceleration and is easier to drive on rough and slick tracks. Thicker center differential has more acceleration, increases on-power steering, and less off-power steering. Thinner rear differential has more cornering traction and increases steering in the middle of the turn. Thicker rear differential has less steering in the middle of the turn and more forward traction.

Tuning the Rear End of the TEN-SCTE

Shock Location: Moving the shocks out on the arm will result in less forward traction and let the TEN-SCTE make more of an arc through the exit of the turn. In general, when changing shock locations on the arm, it will be necessary to go down one spring rate when moving out on the arm.

Static Camber: Having the same definition as for the front end and measured in the same fashion, rear camber can also be a critical tuning feature. Testing has shown that running a small amount of negative camber (.5-1 degree) is best. Increasing negative rear camber (in the range of 1.5-3 degrees) will increase stability and traction in corners, but decrease high-speed stability. Decreasing rear camber (in the range of 0-1.5 degrees) will decrease stability and traction in corners, but will increase high-speed stability.

Inboard Camber Location: The TEN-SCTE has two inner camber link locations. These locations work in the same fashion and have the same effect as noted for the front. You will find that you will get more noticeable changes with the outer locations in the hub. In general the upper hole will make the TEN-SCTE more stable and keep the front end flatter. This works well on higher traction surfaces. The lower location will make the steering more aggressive which works well on lower traction surfaces. This can be good in some conditions but can also make the TEN-SCTE difficult to drive in others.

Outboard Camber Location: Running the camber link in the inside position on the hub will generate more rotation entering a turn, but decrease steering on exit. Running the camber link in the furthest outer position on the hub will generate more stability entering a turn and increase steering on exit.

Toe-In: Having the same definition as for the front end, the toe-in can be adjusted on the TEN-SCTE with the rear hubs. The stock toe-in is 3 degrees of inboard per side and 0 degrees in the hub. Increasing rear toe-in will increase forward traction and initial steering, but reduce straightaway speed. Decreasing rear toe-in will decrease forward traction and "free-up" the TEN-SCTE. Less toe-in can be used to gain top speed.

Ride Height: This is the height of the chassis in relation to the surface. It is an adjustment that affects the way your TEN-SCTE jumps, turns and goes through bumps. To check the ride height, drop one end (front or rear) of the TEN-SCTE from about a 5 to 6-inch height onto a flat surface. Once the TEN-SCTE settles into a position, check the height of that end of the TEN-SCTE in relationship to the surface. To raise the ride height, lower the shock adjuster nuts on the shock evenly on the end (front or rear) of the TEN-SCTE that you are working on. To lower the ride height, raise the shock adjuster nuts. Both left and right nuts should be adjusted evenly. Check the setup sheet included and for additional setup information visit www.losi.com.



Use the same technique to adjust the rear ride height. Again, refer to the included setup sheet. Every driver likes a little different feel so you should try small ride height adjustment to obtain the feel you like. This should be the last adjustments you make after everything else is dialed in. Note: Do not use ride height adjustments as a substitute for a spring rate change. If your TEN-SCTE needs a softer or firmer spring, change the spring. Do not think that simply moving the shock nuts will change the spring stiffness as it will NOT!

Wheels and Tires

The tires come pre-mounted with the vehicle and should be checked to make certain they stay glued to the wheels. The wheel spinning speeds this vehicle is capable of tend to pull the rubber tire away from the rim. When a tire or tires come loose from the rim you will notice the vehicle is hard to control.

Tip the vehicle on its side and using both hands to hold one wheel at a time, use your thumb to press the tire away from the rim. If you see a tire pull away from the rim, use Losi Tire Glue (LOSA7880 thick or LOSA7881 thin) to reglue. It only takes a small drop of glue generally. Be careful—this is CA-type glue and you do not want to glue your fingers to the wheel and tire.

Use safety goggles when gluing tires.

Check the mounting of the tire periodically to ensure proper performance and handling.

Troubleshooting your TEN-SCTE

Many questions are the result of simple user errors or minor adjustments which are easily addressed. If after reading below you cannot resolve your problem, then please contact the appropriate Horizon product support department.

Servicing Your Shocks

From time to time you should check your shocks for adequate fluid. If the fluid is low, or it is getting dirty, you should change the fluid in the shocks. You may also want to change the shock fluid and or the pistons to better address the conditions you are running on. Regardless of what the reason you will want to follow these simple steps to service, refill, and bleed your TEN-SCTE shocks. If you are cleaning or changing the fluid, you will find the LOSA99217 Nitrotec™ Spray Cleaner to be the quickest and easiest way to remove oil fluid and dirt safely.

1. If you are changing the pistons, clean the threads on the end of the shock shaft and apply threadlock (LOSA99202) to the threads.
2. Install the small shock piston washer and shock piston using the 4-40 mini lock nut on the shock shaft to secure them.
3. Put a drop of shock fluid on the shaft before replacing it in the shock body.
4. If you are changing the shock end, use the shock tool provided with the TEN-SCTE to hold the shaft. You will see that this plastic tool has serrations on both sides that allow you to hold it with a pair of pliers and not scratch up the micro finished surface. This method works very well to protect the shock shafts from damage.
5. After installing, make sure the shaft is fully extended when filling the shock.
6. Fill the shock body with 30–35-weight shock fluid until it is to the top of the Body.
7. Work the shock shaft up and down a few times. This will release the air bubbles trapped beneath the piston.
8. Place the filled shock, in the upright position, off to the side for a few minutes until the air bubbles escape from the fluid.
9. Once all the air bubbles are out of the fluid, gently place the shock bladder onto the top of the shock. Some fluid will “bleed” from around the bladder.
10. Screw the shock cap onto the body until a little resistance is felt.
11. Slowly push the shock shaft up. This will allow excess fluid to bleed out.
12. Tighten the cap all the way down using the shock tools included in your kit.
13. Move the shock shaft up and down. The shaft should be easy to push up into the body of the shock.
14. If increased pressure is felt towards the top, there is too much oil in the shock. Loosen the shock cap and bleed the shock as done in steps 11 and 12.
15. Make sure each pair (front/rear) of shocks has the same rebound and compression. This is checked by holding one shock in each hand horizontally and pushing them together by the shock end. Watch carefully to ensure that both compress evenly. Now release both shocks and again watch carefully as they should rebound the same.

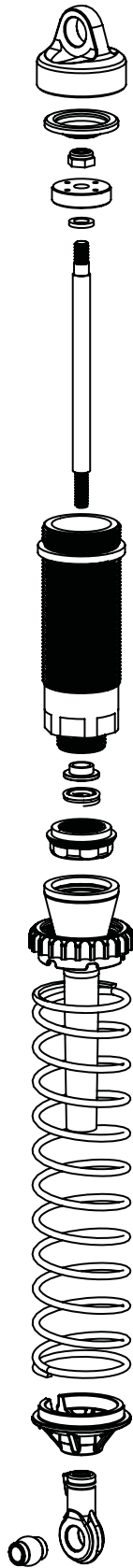

Warranty and Repair Policy

Warranty Period

Exclusive Warranty- Horizon Hobby, Inc., (Horizon) warranties that the Products purchased (the "Product") will be free from defects in materials and workmanship at the date of purchase by the Purchaser.

Limited Warranty

Horizon reserves the right to change or modify this warranty without notice and disclaims all other warranties, express or implied.

(a) This warranty is limited to the original Purchaser ("Purchaser") and is not transferable. REPAIR OR REPLACEMENT AS PROVIDED UNDER THIS WARRANTY IS THE EXCLUSIVE REMEDY OF THE PURCHASER. This warranty covers only those Products purchased from an authorized Horizon dealer. Third party transactions are not covered by this warranty. Proof of purchase is required for all warranty claims.

(b) Limitations- HORIZON MAKES NO WARRANTY OR REPRESENTATION, EXPRESS OR IMPLIED, ABOUT NON-INFRINGEMENT, MERCHANTABILITY OR FITNESS FOR A PARTICULAR PURPOSE OF THE PRODUCT. THE PURCHASER ACKNOWLEDGES THAT THEY ALONE HAVE DETERMINED THAT THE PRODUCT WILL SUITABLY MEET THE REQUIREMENTS OF THE PURCHASER'S INTENDED USE.

(c) Purchaser Remedy- Horizon's sole obligation hereunder shall be that Horizon will, at its option, (i) repair or (ii) replace, any Product determined by Horizon to be defective. In the event of a defect, these are the Purchaser's exclusive remedies. Horizon reserves the right to inspect any and all equipment involved in a warranty claim. Repair or replacement decisions are at the sole discretion of Horizon. This warranty does not cover cosmetic damage or damage due to acts of God, accident, misuse, abuse, negligence, commercial use, or modification of or to any part of the Product. This warranty does not cover damage due to improper installation, operation, maintenance, or attempted repair by anyone other than Horizon. Return of any Product by Purchaser must be approved in writing by Horizon before shipment.

Damage Limits

HORIZON SHALL NOT BE LIABLE FOR SPECIAL, INDIRECT OR CONSEQUENTIAL DAMAGES, LOSS OF PROFITS OR PRODUCTION OR COMMERCIAL LOSS IN ANY WAY CONNECTED WITH THE PRODUCT, WHETHER SUCH CLAIM IS BASED IN CONTRACT, WARRANTY, NEGLIGENCE, OR STRICT LIABILITY. Further, in no event shall the liability of Horizon exceed the individual price of the Product on which liability is asserted. As Horizon has no control over use, setup, final assembly, modification or misuse, no liability shall be assumed nor accepted for any resulting damage or injury. By the act of use, setup or assembly, the user accepts all resulting liability.

If you as the Purchaser or user are not prepared to accept the liability associated with the use of this Product, you are advised to return this Product immediately in new and unused condition to the place of purchase.

Law: These Terms are governed by Illinois law (without regard to conflict of law principals).



Warranty Services

Questions, Assistance, and Repairs

Your local hobby store and/or place of purchase cannot provide warranty support or repair. Once assembly, setup or use of the Product has been started, you must contact Horizon directly. This will enable Horizon to better answer your questions and service you in the event that you may need any assistance. For questions or assistance, please direct your email to productsupport@horizonhobby.com, or call 877.504.0233 toll free to speak to a Product Support representative. You may also find information on our website at www.horizonhobby.com.

Inspection or Repairs

If this Product needs to be inspected or repaired, please use the Horizon Online Repair Request submission process found on our website or call Horizon to obtain a Return Merchandise Authorization (RMA) number. Pack the Product securely using a shipping carton. Please note that original boxes may be included, but are not designed to withstand the rigors of shipping without additional protection. Ship via a carrier that provides tracking and insurance for lost or damaged parcels, as Horizon is not responsible for merchandise until it arrives and is accepted at our facility. An Online Repair Request is available at www.horizonhobby.com <http://www.horizonhobby.com> under the Repairs tab. If you do not have internet access, please contact Horizon Product Support to obtain a RMA number along with instructions for submitting your product for repair. When calling Horizon, you will be asked to provide your complete name, street address, email address and phone number where you can be reached during business hours. When sending product into Horizon, please include your RMA number, a list of the included items, and a brief summary of the problem. A copy of your original sales receipt must be included for warranty consideration. Be sure your name, address, and RMA number are clearly written on the outside of the shipping carton.

Notice: Do not ship batteries to Horizon. If you have any issue with a battery, please contact the appropriate Horizon Product Support office.

Warranty Inspection and Repairs

To receive warranty service, you must include your original sales receipt verifying the proof-of-purchase date. Provided warranty conditions have been met, your Product will be repaired or replaced free of charge. Repair or replacement decisions are at the sole discretion of Horizon.

Non-Warranty Repairs

Should your repair not be covered by warranty the repair will be completed and payment will be required without notification or estimate of the expense unless the expense exceeds 50% of the retail purchase cost. By submitting the item for repair you are agreeing to payment of the repair without notification. Repair estimates are available upon request. You must include this request with your repair. Non-warranty repair estimates will be billed a minimum of ½ hour of labor. In addition you will be billed for return freight. Horizon accepts money orders and cashiers checks, as well as Visa, MasterCard, American Express, and Discover cards.

By submitting any item to Horizon for inspection or repair, you are agreeing to Horizon's Terms and Conditions found on our website under the Repairs tab.

United States

(Electronics and engines)
Horizon Service Center
4105 Fieldstone Rd
Champaign, Illinois
61822 USA
877-504-0233

Online Repair Request visit:
www.horizonhobby.com/repairs

(All other products)
Horizon Product Support
4105 Fieldstone Rd
Champaign, Illinois
61822 USA
productsupport@horizonhobby.com
877-504-0233

United Kingdom

Horizon Hobby Limited
Units 1-4 Ployters Rd
Staple Tye
Harlow, Essex
CM18 7NS
United Kingdom
sales@horizonhobby.co.uk
+44 (0) 1279 641 097

Germany

Horizon Technischer Service
Hamburger Str. 10
25335 Elmshorn
Germany
service@horizonhobby.de
+49 4121 46199 66

France

Horizon Hobby SAS
14 Rue Gustave Eiffel
Zone d'Activité du Réveil Matin
91230 Montgeron
infofrance@horizonhobby.com
+33 (0) 1 60 47 44 70

Compliance Information for the European Union



INSTRUCTIONS FOR DISPOSAL OF WEEE BY USERS IN THE EUROPEAN UNION

This product must not be disposed of with other waste. Instead, it is the user's responsibility to dispose of their waste equipment by handing it over to a designated collection point for the recycling of waste electrical and electronic equipment. The separate collection and recycling of your waste equipment at the time of disposal will help to conserve natural resources and ensure that it is recycled in a manner that protects human health and the environment. For more information about where you can drop off your waste equipment for recycling, please contact your local city office, your household waste disposal service or where you purchased the product.



REPLACEMENT PARTS LIST

Part Number	Description		
LOSB2021	Front Suspension Arm Set: 10-T	LOSB3572	Rear Ring and Pinion Gear Set: 10-T
LOSB2022	Rear Suspension Mount Cover: TEN-SCTE	LOSB3574	Axle (2): TEN-SCTE
LOSB2023	Rear Suspension Arm Set: 10-T	LOSB3578	Center Rear Drive Shaft: TEN-SCTE
LOSB2100	Front Spindles and Carriers: 10-T	LOSB3592	Differential Standoff: TEN-SCTE
LOSB2103	Rear Hubs and Spacers: 10-T	LOSB4003	F/R Camber/Steering Turnbuckle Set: 10-T
LOSB2123	Steering Bellcrank Set: 10-T	LOSB4023	Rod End Set (15): 10-T
LOSB2124	Steering Posts/Tube and Hardware: 10-T	LOSB4022	Camber and Steering Ball Set (12): 10-T
LOSB2163	Front Shock Towers and Caps: 10-T	LOSB4109	Suspension Hinge and King Pin Set (10): 10-T
LOSB2170	Rear Shock Tower: 10-T	LOSB4210	Steering/Throttle/Brake Link Set: 10-T
LOSB2211	Front and Rear Pin Mount Cover Set: 10-T	LOSB7018	Wheel Set (2): TEN-SCTE
LOSB2213	Pivot Pin Mount Set (4): 10-T	LOSB7019	Beadlock Ring with Screws, Chrome:XXX-SCT/ TEN-SCTE (2)
LOSB2222	Front and Rear Sway Bar Set: 10-T	LOSB8028	TEN-SCTE Body, Clear
LOSB2278	Chassis Brace and Spacer Set (3): 10-T	LOSA4006	Antenna Kit
LOSB2279	Steering Drag Link and Hardware: 10-T	LOSA6204	4-40 x 1/2 Cap Screws
LOSB2359	Radio Tray with Switch Cover Blank and Receiver Cover: TEN-SCTE	LOSA6206	4-40 x 3/8 Cap Screws
LOSB2411	Chassis: TEN-SCTE	LOSA6227	4-40 x 1/8 Setscrews
LOSB2412	Top Brace: TEN-SCTE	LOSA6229	4-40 x 3/8 Button Head Screws
LOSB2413	Motor Mount with Adapter: TEN-SCTE	LOSA6240	5-40 x 1/2 Cap Screws
LOSB2414	Body Posts: TEN-SCTE	LOSA6250	4mm and 5mm Setscrews
LOSB2415	Battery Tray with Stop Tab, Foam Pad and Screws: TEN-SCTE	LOSA6254	2-56 x 1/4 Cap Screws
LOSB2416	Battery Straps (2): TEN-SCTE	LOSA6256	4-40 x 1/2 Button Head Screws
LOSB2417	Rear Bumper Pack: TEN-SCTE	LOSA6264	8-32 x 3/8 Flat Head Screws
LOSB2418	Rear Mud Flap (2): XXX-SCT/TEN-SCTE	LOSA6270	5-40 x 3/8 Flat Head Screws
LOSB2419	Sideguards: TEN-SCTE	LOSA6271	5-40 x 1/2 Flat Head Screws
LOSB2421	Front Bumper Pack: TEN-SCTE	LOSA6272	5-40 x 3/4 Flat Head Screws
LOSB2825	Front Shock Body Set: 10-T	LOSA6275	5-40 x 5/8 Flat Head Screws
LOSB2826	Rear Shock Body Set: 10-T	LOSA6277	5-40 x 3/8 Button Head Screws
LOSB2845	Front and Rear Shock Shaft Set: 10-T	LOSA6278	5-40 x 1/2 Button Head Screws
LOSB2904	Front and Rear Shock Plastics and Ball Set (4): 10-T	LOSA6279	5-40 x 3/4 Button Head Screws
LOSB2905	Front and Rear Shock Boots (8): 10-T	LOSA6282	5-40 x 7/8 Button Head Screws
LOSB2906	Shock Rebuild Set (2): 10-T	LOSA6286	5-40 x 5/8 Button Head Screws
LOSB2961	Front and Rear Spring Set (4)-Med (Black): 10-T	LOSA6290	8-32 x 1/2 Button Head Screws
LOSB3104	Front and Rear Gearbox Set: 10-T	LOSA6293	8-32 x 1/4 Setscrews
LOSB3436	40T Spur Gear, Mod 1: TEN-SCTE	LOSA6295	10-32 x 3/8 Setscrews
LOSB3495	Wheel Hex (4) with Pins: TEN-SCTE	LOSA6298	8-32 x 1/8 Setscrews
LOSB3536	Center Differential Mount and Shock Tool Set: 10-T	LOSA6299	5-40 x 1/8 Setscrews
LOSB3542	Differential Housing and Seal Set: 10-T	LOSA6302	5-40 Steel Lock Nuts
LOSB3553	Center Differential Outdrive Set: 10-T	LOSA6350	#4 and 1/8-Inch Hardened Washer (24)
LOSB3555	Center Front CV Driveshaft Assembly: 10-T	LOSA6907	5 x 8 x 2.5 Ball Bearing (2)
LOSB3556	Center CV Driveshaft Couplers: 10-T	LOSA6947	5 x 11 Sealed Ball Bearings (2)
LOSB3563	F/R Differential Outdrive and Hard Set (2)	LOSA6954	5 x 10 x 4 Sealed Ball Bearings (2)
LOSB3564	F/R CV Driveshafts and Couplers (2): 10-T	LOSA6956	12 x 18 x 4 Sealed Ball Bearings (2)
LOSB3565	F/R CV Couplers (4): 10-T	LOSA6957	10 x 15 x 4 Sealed Ball Bearings with Plastic Retainer (2)
LOSB3568	Differential Seals/Pin and Gasket: 10-T	LOSA6958	6 x 12 x 4 Sealed Ball Bearings with Plastic Retainer (2)
LOSB3569	Differential Gear Set with Hardware: 10-T	LOSA7215	Eclipse SCT Tires with Foams
LOSB3571	Front Ring and Pinion Gear Set: 10-T		



OPTIONAL PARTS LIST

Part Number	Description		
LOSA5224	Certified Shock Fluid 30 wt.	LOSB2167	Front Shock Tower, Machined Aluminum: TEN
LOSA5225	Certified Shock Fluid 35 wt.	LOSB2171	Rear Shock Tower, Machined Aluminum: TEN
LOSA5226	Certified Shock Fluid 40 wt.	LOSB2172	Rear Shock Tower, Carbon, 4mm: TEN
LOSA99004	Losi Cargo Bag	LOSB2173	Front Shock Tower, Carbon, 4mm: TEN
LOSA99006	Losi Pit Roller Carrier/Pit Boxes	LOSB2130	Rear Hubs, Aluminum: TEN
LOSA99013	Losi Large Pit Mat	LOSB2223	Front Chassis Brace, Aluminum: TEN
LOSA99015	Losi Pit Apron	LOSB2224	Rear Chassis Brace, Aluminum: TEN
LOSA99104	Losi Wrench Set US (4 pc)	LOSB2846	Shock Tops, Aluminum (2): TEN
LOSA99165	Aluminum Turnbuckle Wrench	LOSB2907	One-Piece Shock Standoffs: TEN
LOSA99772	Camber Gauge	LOSB2908	Shock Collars, Aluminum (2): TEN
LOSA99173	Ride Height Gauge	LOSB2909	Piston Pack (2), Ten-T, TEN-SCTE
LOSA99174	Car Stand	LOSB2960	Front and Rear Spring Set (4)–Soft (Silver): 10-T
LOSA99202	Losi-Lok Threadlock, Blue	LOSB2962	Front and Rear Spring Set (4)–Firm (Gold): 10-T
LOSA99203	High-Pressure Black Grease	LOSB4112	Adjustable Front Hinge Pin Holder Set: TEN
LOSA99217	Nitrotec Cleaner Spray	LOSB4113	Adjustable Rear Hinge Pin Holder Set: TEN

Name: Ten-SCTE		Date: 10/06/10	Event:
City:		Track:	
State:			
Track	<input checked="" type="checkbox"/> Indoor	<input type="checkbox"/> Tight	<input checked="" type="checkbox"/> Smooth
Conditions	<input type="checkbox"/> Outdoor	<input checked="" type="checkbox"/> Open	<input type="checkbox"/> Rough
		<input checked="" type="checkbox"/> Hard Packed	<input type="checkbox"/> Blue Groove
		<input type="checkbox"/> Loose/Loamy	<input type="checkbox"/> Dry
		<input type="checkbox"/> Wet	<input type="checkbox"/> Low Bite
		<input type="checkbox"/> Dusty	<input checked="" type="checkbox"/> Med Bite
			<input type="checkbox"/> High Bite
			<input type="checkbox"/> Other _____

Front Suspension

Toe: **1 degrees OUT**

Ride Height: **29.5mm**

Camber: **0 degree**

Caster: **Stock/20 degrees**

Sway Bar: **2.0mm**

Piston/Oil: **4 holes @ 1.07mm/40 wt**

Spring: **Gold/Hard**

Limiters/Droop: _____

Overall Shock Length: **85mm Center to Center**

Steering Ackerman: **Long**

Bump Steer: **Up**

Camber Link: **Position 1**

Shock Location: **Position 1 / Outside**

Front Diff Fluid: **Grease**

Center Diff Fluid: **Grease**

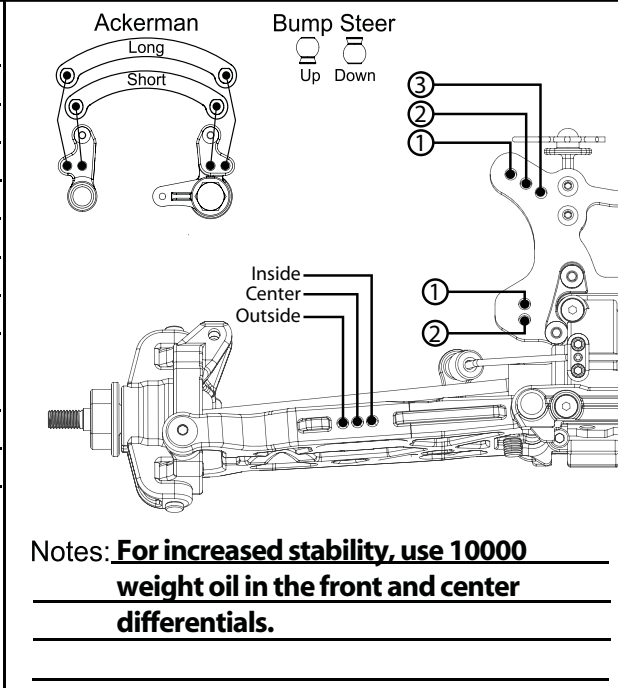

Rear Suspension

Toe: **3 degrees**

Anti-Squat: **2 degrees**

Ride Height: **24.5mm**

Camber: **-2.5 degrees**

Rear Hub Spacing: **All the way back**

Sway Bar: **1.8mm**

Piston/Oil: **4 holes @ 1.09mm/30 wt**

Spring: **Black/Medium**

Limiters/Droop: _____

Overall Shock Length: **100.8mm Center to Center**

Camber Link: **Position 2 - A**

Shock Location: **Position 2 - Inside**

Rear Diff Fluid: **Grease**

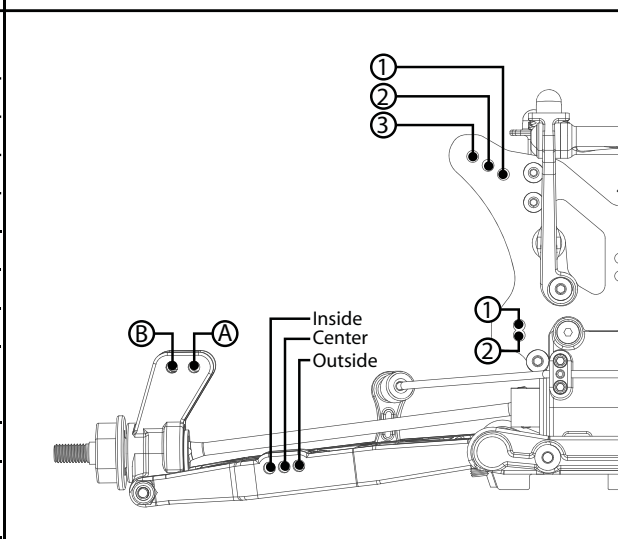

Electronics

Motor: **Losi 3.4**

ESC: _____

Battery: **Stock** Gearing: _____

Notes

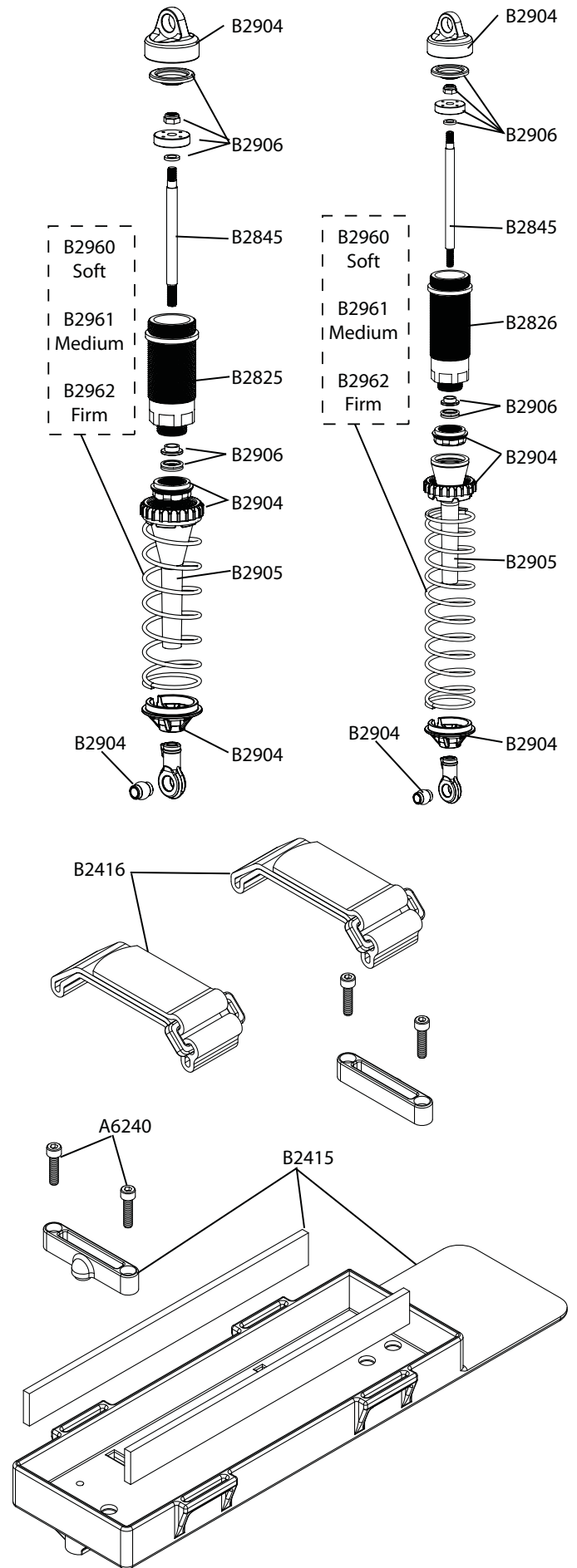
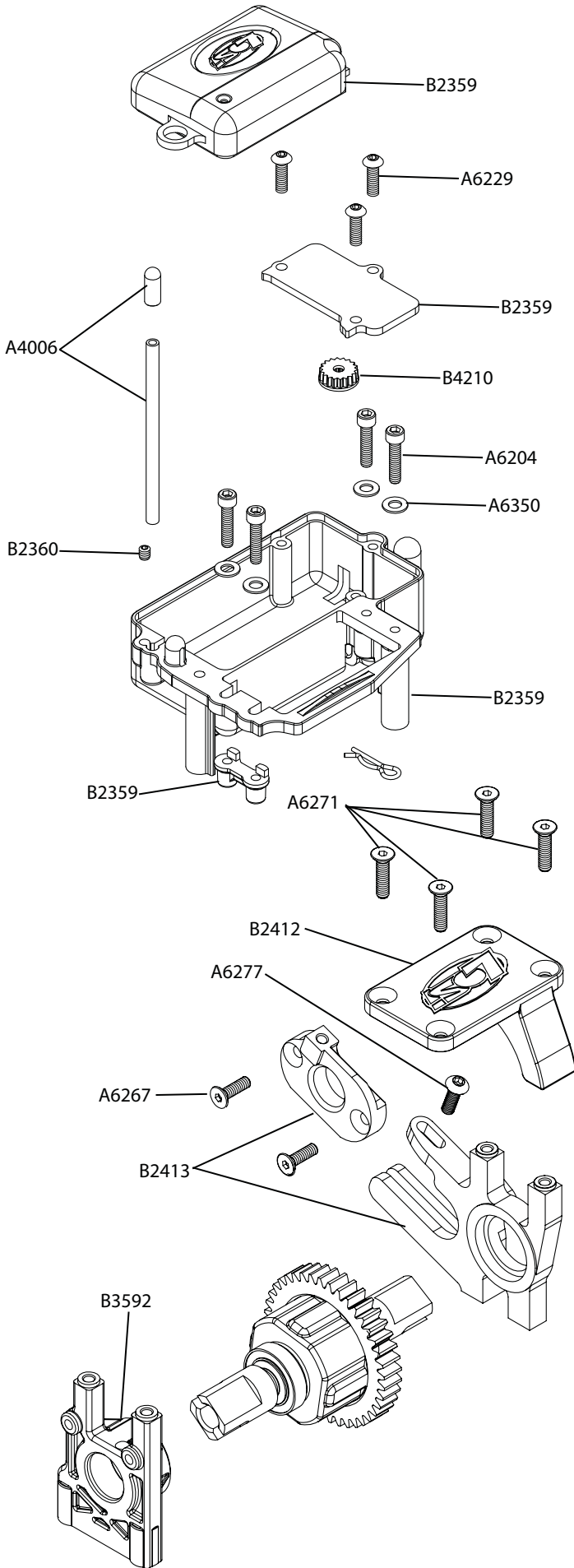

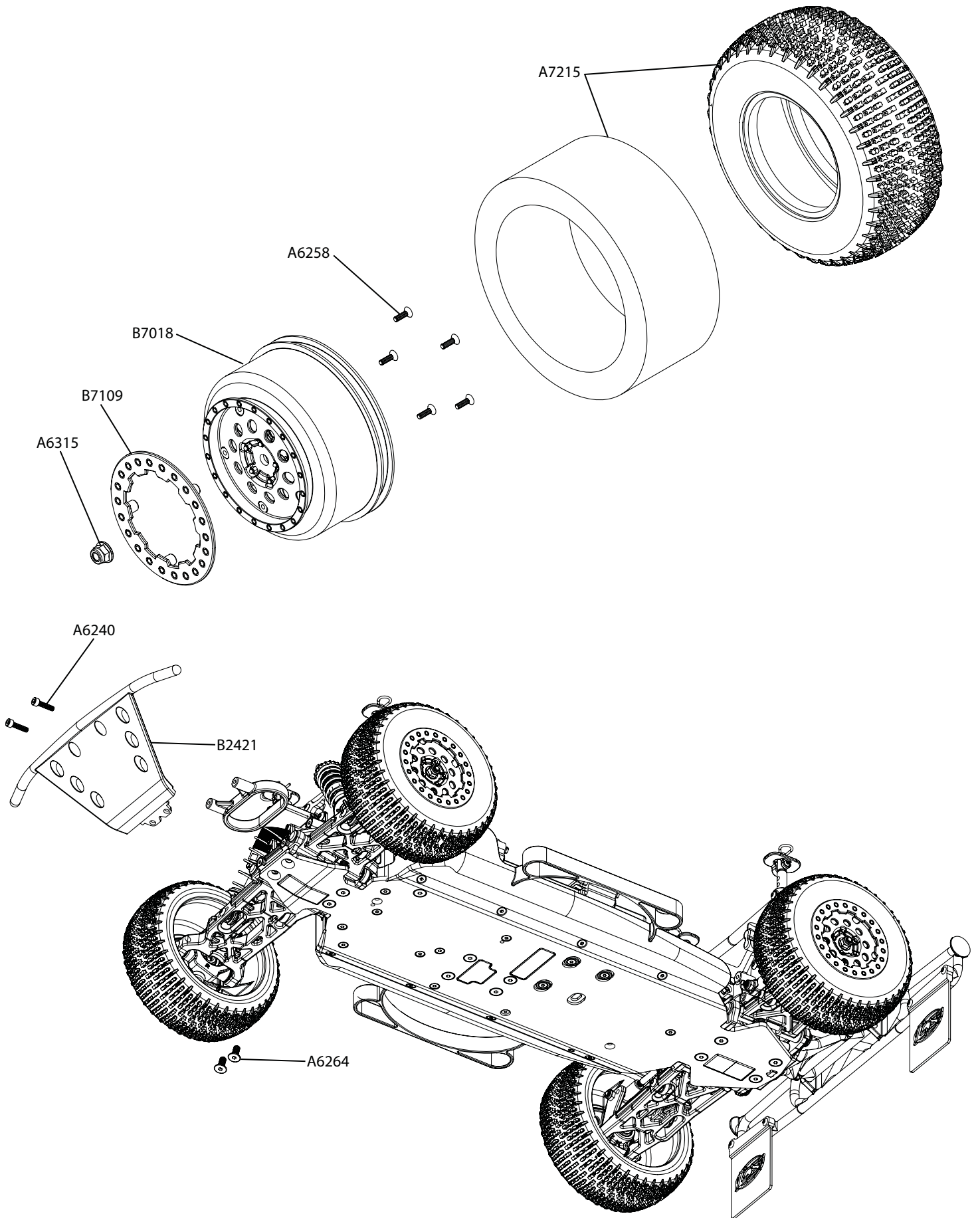



TEN SCITE



©2010 Horizon Hobby, Inc.
Not responsible for typographical errors.

*The Spektrum trademark is used with permission of Bachmann Industries, Inc.
Losi, Xcelorin and MultiPro are trademarks or registered trademarks of Horizon Hobby, Inc.
Airtronics® is a registered mark of Sanwa Electronic Instrument Co., Ltd., Osaka, Japan.
Futaba is a registered trademark of Futaba Denshi Kagyo Kabushiki Kaisha Corporation of Japan
KO PROPO® is a registered trademark of Kondo Kagaku Co., Ltd., Tokyo, Japan.*

Printed 11/2010
30160.I