

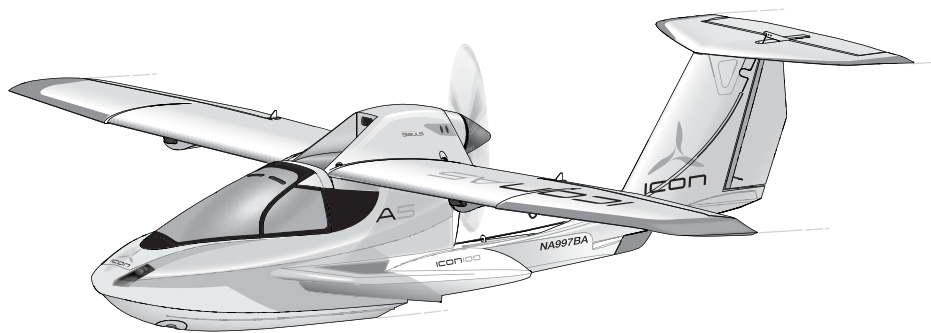

ULTRA
MICRO
SERIES

Ultra Micro ICON A5



ICON, the ICON logo, ICON A5 and its body design are trademarks or registered trademarks of ICON Aircraft, Inc. and are used with permission by Horizon Hobby, Inc.

*Instruction Manual / Bedienungsanleitung
Manuel d'utilisation / Manuale di Istruzioni*



NOTICE

All instructions, warranties and other collateral documents are subject to change at the sole discretion of Horizon Hobby, Inc. For up-to-date product literature, visit www.horizonhobby.com and click on the support tab for this product.

Meaning of Special Language:

The following terms are used throughout the product literature to indicate various levels of potential harm when operating this product:

NOTICE: Procedures, which if not properly followed, create a possibility of physical property damage AND little or no possibility of injury.

CAUTION: Procedures, which if not properly followed, create the probability of physical property damage AND a possibility of serious injury.

WARNING: Procedures, which if not properly followed, create the probability of property damage, collateral damage and serious injury OR create a high probability of superficial injury.



WARNING: Read the ENTIRE instruction manual to become familiar with the features of the product before operating. Failure to operate the product correctly can result in damage to the product, personal property and cause serious injury.

This is a sophisticated hobby product. It must be operated with caution and common sense and requires some basic mechanical ability. Failure to operate this Product in a safe and responsible manner could result in injury or damage to the product or other property. This product is not intended for use by children without direct adult supervision. Do not use with incompatible components or alter this product in any way outside of the instructions provided by Horizon Hobby, Inc. This manual contains instructions for safety, operation and maintenance. It is essential to read and follow all the instructions and warnings in the manual prior to assembly, setup or use in order to operate correctly and avoid damage or serious injury.

Age Recommendation: Not for children under 14 years. This is not a toy.

Welcome to the world of amphibious RC flight! Equipped with removable landing gear for amphibious operation, you'll be able to have equal fun flying from the water or your favorite landing strip. Not only is the ParkZone® Ultra Micro ICON A5 aircraft a licensed replica of the most exciting light sport airplane in general aviation, it boasts a near-perfect scale outline and a special hull design that makes water takeoffs and landings remarkably easy to master. With its included 2500kv brushless motor and 2S 180mAh 20C Li-Po battery, the Ultra Micro ICON A5 has ample power for getting up on plane and off the water.

We encourage you to spend the time to read the contents of this manual. In addition to step-by-step assembly instructions, it contains important preflight and setup tips as well as a handy troubleshooting guide. It's all here to make sure your first flight, and every one after, is as rewarding as can be.

Box Contents

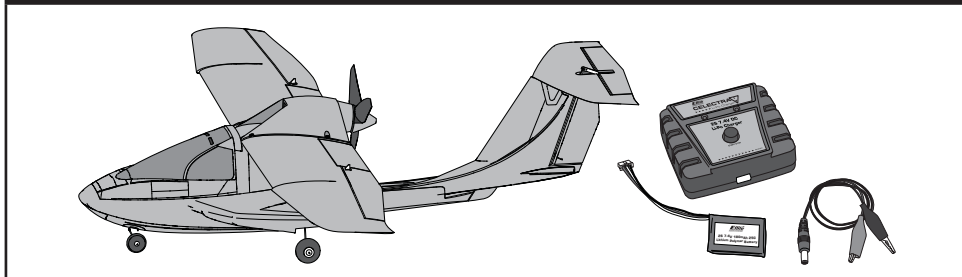
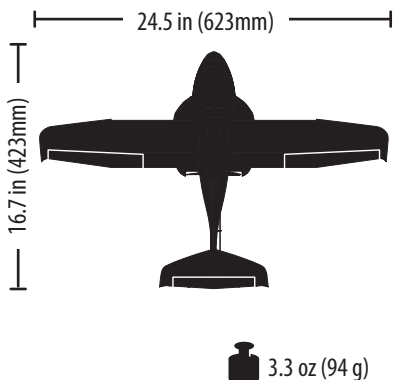

Table of Contents

Charging the Battery	4	Motor Service	11
Charging Warnings.....	5	Removing and Installing the Landing Gear.....	12
AS3X® System Delivers		Additional Safety Precautions and Warnings	12
Breakthrough Performance	6	Flying Tips and Repairs.....	13
Transmitter and Receiver Binding	6	Post Flight Checklist.....	14
Installing the Flight Battery	7	Troubleshooting Guide	14
Connecting the Battery and Arming the ESC	7	Limited Warranty.....	16
Preflight Checklist	8	Warranty and Service Information	17
Control Centering	8	Compliance Information for the	
Settings for Control Horns.....	8	European Union	18
Control Direction Test.....	9	Replacement Parts	69
Control Rates	10	Optional Parts and Accessories	70
Adjusting the Center of Gravity (CG)	10		

Specifications



Installed		Motor: BL180 Brushless Outrunner Motor, 2500Kv (EFLUM180BL2)
Installed		Receiver: DSM2®/DSMX® 6-Channel AS3X® Receiver/ESC (SPMSA6410NBL)
Installed		Servos: (2) 2.3-Gram Performance Linear Long Throw Servos (SPMSA2030L) (2) 2.3-Gram Linear Long Throw Offset Servos (SPMSA2030LO)
Included		Battery: 180mAh 2S 20C Li-Po (EFLB1802S20)
Included		Charger: 2S 7.4V Li-Po Battery Charger (EFLUC1007)
Sold Separately		Recommended Transmitter: DSM2/DSMX 4-Channel Transmitter

To register your product online, go to www.parkzone.com

Charging the Battery

Your aircraft comes with a 2-Cell 7.4V 180mAh 20C Li-Po battery and a Celestra™ 2S 7.4V DC Li-Po charger that requires a 12V (11V-14V) DC power source.

Refer to the charging warnings. It is recommended to charge the battery pack while you are inspecting the aircraft. The flight battery will be required to confirm proper aircraft operation in future steps.

Please visit www.horizonhobby.com for optional battery adapters.

Battery Charging Process

NOTICE: Charge only batteries that are cool to the touch and are not damaged. Look at the battery to make sure it is not damaged e.g., swollen, bent, broken or punctured.

The connector of the battery is specifically designed to allow it to fit into the charge port one way to prevent reverse polarity connection. However, check for proper alignment and polarity before proceeding.

1. Gently press the battery connector into the charge port located on the front of the charger.
2. Press the button on the charger. The red LED will illuminate, indicating charging has begun.
3. Disconnect the battery from the charger when the green LED turns solid. The battery is fully charged.

Charging a fully discharged (not over-discharged) 180mAh battery takes approximately 50–60 minutes at the charger's 300mA charge rate. The included battery can be charged at a rate of up to 3C (540mA).

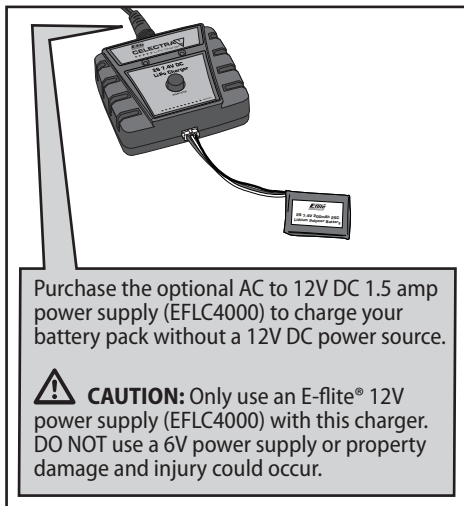

⚠ CAUTION: Once charging is complete, immediately remove the battery. Never leave a battery connected to the charger.

⚠ CAUTION: Only use a charger specifically designed to charge a Li-Po battery. Failure to do so could result in fire causing injury or property damage.

⚠ CAUTION: Never exceed the recommended charge rate.

LED Functions under normal operation

- | | |
|--|----------------------|
| 1. Green LED blinking quickly with power connected but without battery | Standby |
| 2. Green LED blinking slowly | Battery is connected |
| 3. Blinking red LED at varying speeds | Charging |
| 4. Red and green LED blinking simultaneously | Balancing |
| 5. Solid green LED | Full Charge |
| 6. Red and green LED flashing rapidly | Error |

Charging Warnings

The Battery Charger (EFLUC1007) included with your aircraft has been designed to safely charge the Li-Po battery.

 **CAUTION:** All instructions and warnings must be followed exactly. Mishandling of Li-Po batteries can result in a fire, personal injury and/or property damage.

- By handling, charging or using the included Li-Po battery, you assume all risks associated with lithium batteries.
 - If at any time the battery begins to balloon or swell, discontinue use immediately. If charging or discharging, discontinue and disconnect. Continuing to use, charge or discharge a battery that is ballooning or swelling can result in fire.
 - Always store the battery at room temperature in a dry area for best results.
 - Always transport or temporarily store the battery in a temperature range of 40–120° F (5–49° C). Do not store the battery or model in a car or direct sunlight. If stored in a hot car, the battery can be damaged or even catch fire.
 - Always charge batteries away from flammable materials.
- Always inspect the battery before charging.
 - Always disconnect the battery after charging, and let the charger cool between charges.
 - Always constantly monitor the temperature of the battery pack while charging.
 - **ONLY USE A CHARGER SPECIFICALLY DESIGNED TO CHARGE LI-PO BATTERIES.** Failure to charge the battery with a compatible charger may cause a fire resulting in personal injury and/or property damage.
 - Never discharge Li-Po cells to below 3V under load.
 - Never cover warning labels with hook and loop strips.
 - Never leave charging batteries unattended.
 - Never charge batteries outside recommended levels.
 - Never charge damaged batteries.
 - Never attempt to dismantle or alter the charger.
 - Never allow minors to charge battery packs.
 - Never charge batteries in extremely hot or cold places (recommended between 40–120° F or (5–49° C) or place in direct sunlight.

Low Voltage Cutoff (LVC)

When a Li-Po battery is discharged below 3V per cell, it will not hold a charge. The aircraft's ESC protects the flight battery from over-discharge using Low Voltage Cutoff (LVC). Before the battery charge decreases too much, LVC removes power supplied to the motor. Power to the motor quickly decreases and increases, showing that some battery power is reserved for flight control and safe landing.

When the motor power pulses, land the aircraft immediately and recharge the flight battery.

Disconnect and remove the Li-Po battery from the aircraft after use to prevent trickle discharge. Fully charge your Li-Po battery before storing it. During storage, make sure the battery charge does not fall below 3V per cell.

LVC does not prevent the battery from over-discharge during storage.

For your first flights, set your transmitter timer or a stopwatch to 4 minutes. Adjust your timer for longer or shorter flights once you have flown the model. Flights of 6 minutes or more are achievable if using proper throttle management.

NOTICE: Repeated flying to LVC will damage the battery.

AS3X® System Delivers Breakthrough Performance

Horizon Hobby has always made RC sport, scale and unique aircraft with the kind of performance experts appreciate. Now the exclusive Artificial Stability – 3 aXis (AS3X) system helps take performance expectations in ultra micro aircraft a quantum leap higher.

Based on the successful use of MEMS sensor technology within the AS3X Stabilization System essential to Blade® ultra micro flybarless helicopters, the specifically tuned

AS3X System for airplanes helps invisibly correct for turbulence, torque and tip stalls when encountered. Furthermore, the outstanding control agility delivers an ultra smooth, locked-in feel that obeys your every command with performance that's natural feeling. It's so gratifying, in fact, that it's as though you're the RC pilot of an expertly tuned, giant-scale model.

AS3X will change the way you'll want to fly now and in the future. To see what we mean, go to www.E-fliteRC.com/AS3X.

Transmitter and Receiver Binding

Binding is the process of programming the receiver to recognize the GUID (Globally Unique Identifier) code of a single specific transmitter. You need to 'bind' your chosen Spektrum™ DSM2/DSMX technology equipped aircraft transmitter to the receiver for proper operation.

For a list of compatible DSM2/DSMX transmitters, please visit www.bindnfly.com.



CAUTION: When using a Futaba® transmitter with a Spektrum DSM module, you must reverse the throttle channel and rebind. Refer to your Spektrum module manual for binding and failsafe instructions. Refer to your Futaba transmitter manual for instructions on reversing the throttle channel.

✓ Binding Procedure Reference Table

1.	Refer to your transmitter's unique instructions for binding to a receiver.
2.	Make sure the flight battery is disconnected from the aircraft.
3.	Ensure the transmitter is powered OFF.
4.	Connect the flight battery to the aircraft. The receiver LED will begin to flash (typically after 5 seconds).
5.	Make sure the transmitter controls are at neutral and the throttle is in the low position.
6.	Put your transmitter into bind mode.
7.	After 5 to 10 seconds, the receiver status LED will become solid, indicating that the receiver is bound to the transmitter. If the LED does not turn solid, refer to the Troubleshooting Guide at the end of the manual.

For subsequent flights, power ON the transmitter for 5 seconds before connecting the flight battery.

Installing the Flight Battery

1. Remove the magnetic canopy.
2. Install the battery all the way to the front of the battery compartment.
3. Refer to the "Connecting the Battery and Arming the ESC" section below.
4. Reinstall the canopy.

⚠ CAUTION: Always disconnect the Li-Po battery from the aircraft receiver when not flying to avoid over-discharging the battery. Batteries discharged to a voltage lower than the lowest approved voltage may become damaged, resulting in loss of performance and potential fire when batteries are charged.

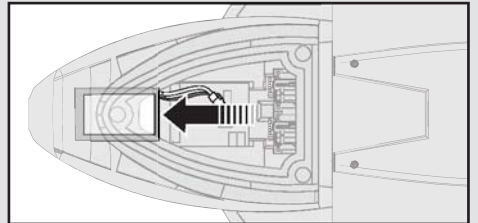
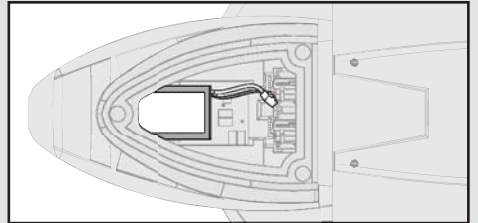
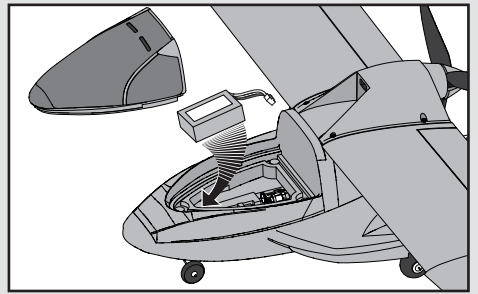

Connecting the Battery and Arming the ESC

Arming the ESC also occurs after binding as previously described, but subsequent connection of a flight battery requires the steps below.

If you accidentally connect the battery while the throttle is fully opened, a musical tone will sound after 5 seconds. Disconnect the battery immediately.

The AS3X system will not activate until the throttle stick or trim is increased for the first time. Once active, the control surfaces may move rapidly and noisily on the aircraft. This is normal. The AS3X system will remain active until the battery is disconnected.

⚠ CAUTION: Always keep hands away from the propeller. When armed, the motor will turn the propeller in response to any throttle movement.

Lower throttle and throttle trim to lowest settings.

Power ON the transmitter, then wait 5 seconds.



Install flight battery and connect it to the ESC.

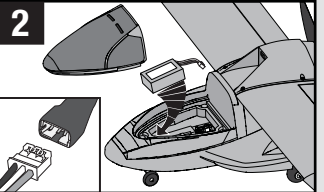

Keep plane immobile and away from wind for 5 seconds.

- Series of tones

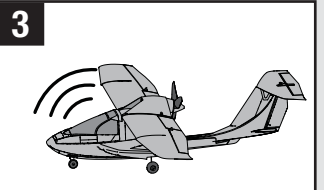

Preflight Checklist

✓	
	1. Charge the flight battery.
	2. Install the flight battery in the aircraft (once it has been fully charged).
	3. Bind the aircraft to the transmitter.
	4. Make sure the linkages move freely.
	5. Perform the Control Direction Test with the transmitter.

✓	
	6. Adjust the center of gravity.
	7. Perform a radio system Range Check
	8. Find a safe and open area.
	9. Plan flight appropriate for flying location.

Control Centering

Before first flights, or in the event of an accident, make sure the flight control surfaces are centered. Adjust the linkages mechanically if the control surfaces are not centered.

Use of the transmitter trims will not correctly center the aircraft control surfaces due to the mechanical limits of linear servos.

1. Make sure the control surfaces are neutral when the transmitter controls and trims are centered. The transmitter sub-trim must be set to zero.
2. When needed, use a pair of pliers to carefully bend the metal of the linkage (see illustration).
3. Make the U-shape narrower to make the connector shorter. Make the U-shape wider to make the linkage longer.

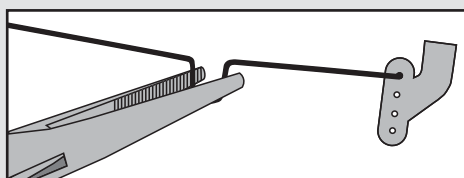

Centering Controls After First Flights

For best performance with AS3X, it is important that excessive trim is not used. If the aircraft requires excessive transmitter trim (4 or more clicks of trim per channel), return the transmitter trim to zero and adjust the linkages mechanically so that the control surfaces are in the flight trimmed position.

Settings for Control Horns

The illustration shows factory settings for linkages on the control horns. After flying, if you want to modify control throw, carefully adjust the linkage positions for desired control response.

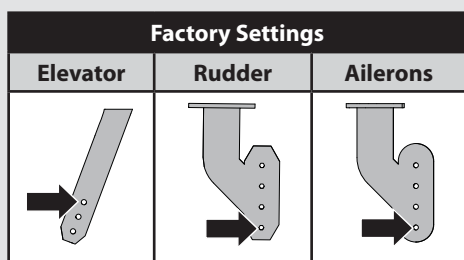

Control Direction Test

Bind your aircraft and transmitter before doing these tests. Move the controls on the transmitter to make sure the aircraft control surfaces move correctly. **Always keep throttle at the low position during testing.**

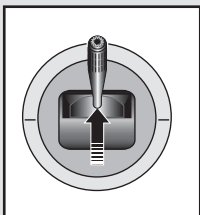

Down Elevator

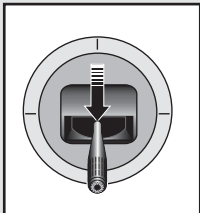
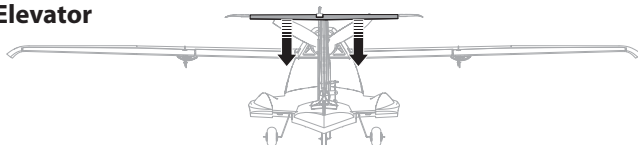

Up Elevator

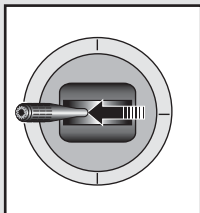
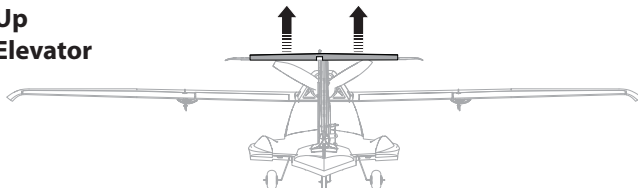

Left Aileron

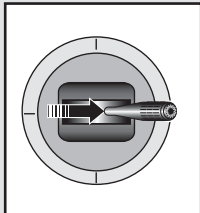
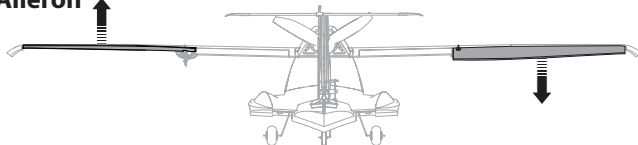

Right Aileron

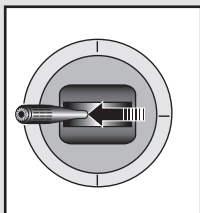
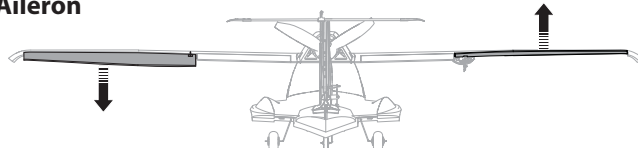

Left Rudder

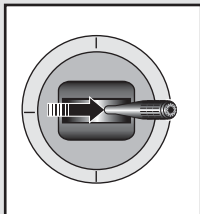
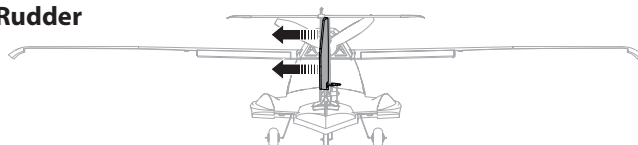

Right Rudder

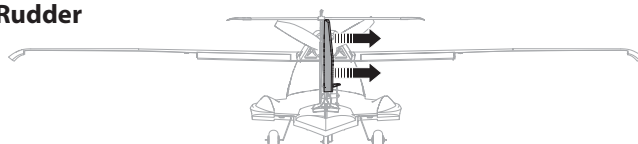

Control Rates

We recommend using a DSM2/DSMX aircraft transmitter capable of dual rates. Adjust according to individual preferences after initial flight.

It is normal for linear servos to make noise. Noise is not an indication of a faulty servo.

To achieve the proper Low Rate settings when using a programmable DSM2/DSMX aircraft transmitter, set the low rate value to 70% for the aileron, elevator and rudder.

NOTICE: Do not set your transmitter travel adjust over 100%. If the TRAVEL ADJUST is set over 100%, it will not result in more control movement, it will overdrive the servo and cause damage.

	High Rate	Low Rate
Aileron	100%	70%
Elevator	100%	70%
Rudder	100%	70%

Adjusting the Center of Gravity (CG)

The CG location is **21mm** back from the leading edge at the wing root.

This CG location has been determined with the included 2S 180mAh 7.4V Li-Po battery installed in the battery cavity.

Balance the model on the underside of each wing to find the center of gravity.

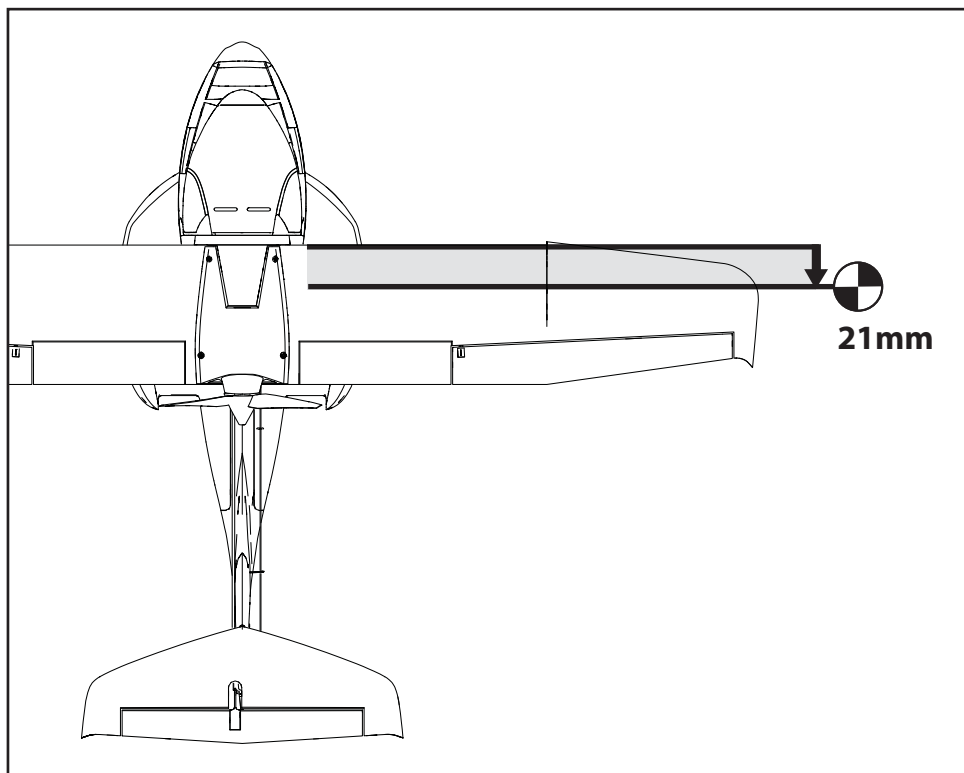

Motor Service

⚠ CAUTION: DO NOT handle propeller parts while the flight battery is connected. Personal injury could result.

Disassembly

1. Remove the spinner (A) from the propeller (B). Glue residue will need to be cleaned from the spinner or propeller if these parts are used again.
2. Carefully remove the screw (C) and propeller (B) from the motor shaft (D).
3. Remove the 4 screws from the cowling (E).
4. Carefully remove the cowling from the fuselage.
5. Remove the top screw (F) from the firewall (G) and motor (H). The motor magnets may attract screws to the motor.
6. Disconnect the motor wire connector from the ESC/receiver connector.

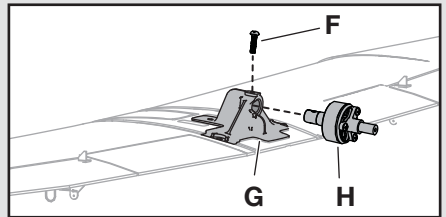
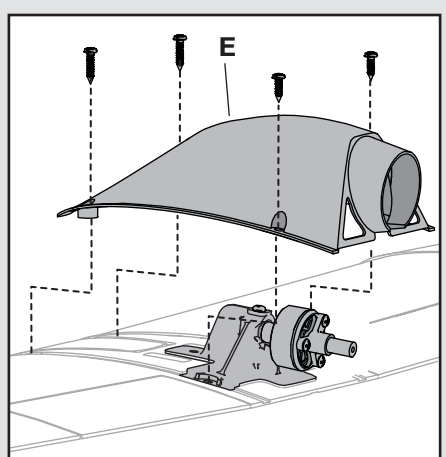
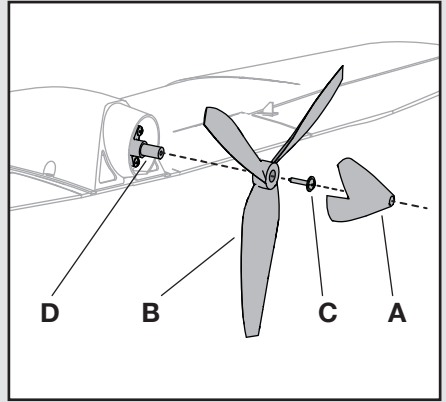

Assembly

Assemble in reverse order.

- Connect the motor to the ESC/receiver.
- Make sure the propeller size numbers (100 x 100) face the motor.
- Install the spinner on the propeller using foam-compatible CA (Cyanoacrylate adhesive).

Removing and Installing the Landing Gear

To remove the factory-installed landing gear, gently pull the landing gear out of the fuselage.

Install in reverse order, making sure the landing gear is fully seated in the fuselage.

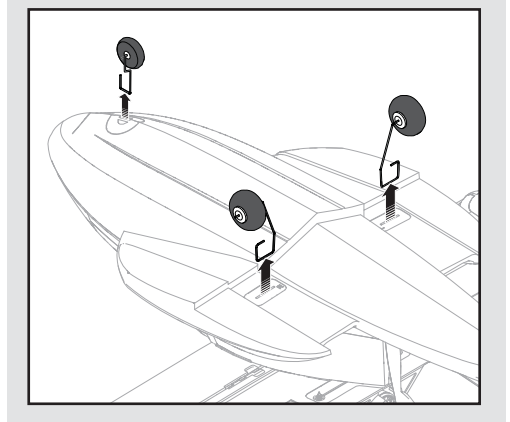

Additional Safety Precautions and Warnings

As the user of this product, you are solely responsible for operating it in a manner that does not endanger yourself and others or result in damage to the product or the property of others.

- Always keep a safe distance in all directions around your model to avoid collisions or injury. This model is controlled by a radio signal subject to interference from many sources outside your control. Interference can cause momentary loss of control.
- Always operate your model in open spaces away from full-size vehicles, traffic and people.
- Always carefully follow the directions and warnings for this and any optional support equipment (chargers, rechargeable battery packs, etc.).
- Always keep all chemicals, small parts and anything electrical out of the reach of children.
- Always avoid water exposure to all equipment not specifically designed and protected for this purpose. Moisture causes damage to electronics.
- Never place any portion of the model in your mouth as it could cause serious injury or even death.
- Never operate your model with low transmitter batteries.
- Always keep the aircraft in sight and under control.
- Always use fully charged batteries.
- Always keep the transmitter powered ON while the aircraft is powered.
- Always remove batteries before disassembly.
- Always keep moving parts clean.
- Always keep parts dry.
- Always let parts cool after use before touching.
- Always remove batteries after use.
- Always ensure failsafe is properly set before flying.
- Never operate aircraft with damaged wiring.
- Never touch moving parts.

Flying Tips and Repairs

Flying

We recommend flying your ICON A5 outside in no greater than moderate winds. Always avoid flying near houses, trees, wires and buildings. You should also be careful to avoid flying in areas where there are many people, such as busy parks, schoolyards or soccer fields. Consult local laws and ordinances before choosing a location to fly your aircraft.

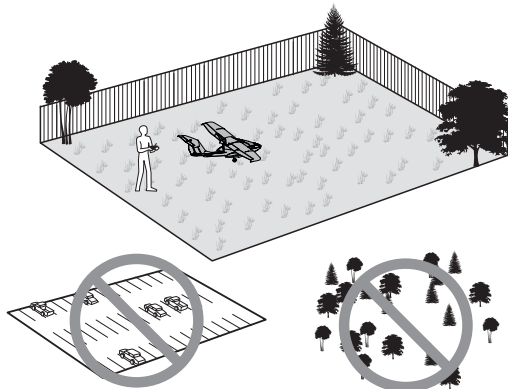

Takeoff

Place the aircraft in position for takeoff (facing into the wind if flying outdoors). Gradually increase the throttle to full and steer with the rudder. Pull back gently with the elevator and climb to check trim. Once the trim is adjusted, begin exploring the flight envelope of the aircraft.

Takeoff from Water

Refer to the Removing and Installing the Landing Gear section to remove the factory-installed landing gear before flying on water.

To take off on water, steer with the rudder and slowly increase the throttle. Keep the wings level on takeoff using the ailerons. Hold a small amount (1/4–1/3) of up elevator and the aircraft will lift off once flying speed is reached. Avoid rapidly increasing the throttle as torque from the motor may cause the aircraft to roll to the left when on water.

When taxiing, you must use some throttle to create propeller blast over the rudder to steer, as there is no water rudder.

Avoid taxiing cross wind if there is a breeze, as this can cause the aircraft to flip over if the wind gets under the upwind wing. Taxi 45 degrees into the direction of the wind (not perpendicular to the

wind) and use aileron to hold the upwind wing down. The wind naturally turns the aircraft to face into the wind when taxiing.

 **CAUTION:** Never go alone to get a downed model in the water.

If at any time water splashes into the fuselage, bring the aircraft to shore, remove the canopy and immediately remove any water that may have gotten into the fuselage. Leave the canopy off overnight to let the inside dry out and to prevent moisture damage to the electronic components.

Landing

Make sure to land into the wind. Fly the aircraft to approximately 6 inches (15cm) or less above the surface, using a small amount of throttle for the entire descent. Keep the throttle on until the aircraft is ready to flare. During flare, keep the wings level and the aircraft pointed into the wind. Gently lower the throttle while pulling back on the elevator to set the aircraft gently on the surface.

Over Current Protection (OCP)

The ICON A5 ESC is equipped with Over Current Protection (OCP). OCP protects the ESC from overheating and stops the motor when the transmitter throttle is set too high and the propeller cannot turn. OCP will only activate when the throttle is positioned just above 1/2 throttle. After the ESC stops the motor, fully lower the throttle to re-arm the ESC.

Failure to lower the throttle stick and trim to the lowest possible positions during a crash could result in damage to the ESC in the receiver unit, which may require replacement.

NOTICE: Crash damage is not covered under warranty.

Repairs

Repairs can be made using foam-compatible CA glue (Cyanoacrylate adhesive) or clear tape. Only use foam-compatible CA glue, as other types of glue can damage the foam. When parts are not repairable, see the Replacement Parts List for ordering by item number.

NOTICE: Use of foam-compatible CA accelerant on your aircraft can damage paint. DO NOT handle the aircraft until accelerant fully dries.

For a listing of all replacement and optional parts, refer to the list at the back of this manual.

Post Flight Checklist

✓	
	1. Disconnect the flight battery from the ESC (Required for safety and battery life).
	2. Power OFF the transmitter.
	3. Remove the flight battery from the aircraft.

✓	
	4. Recharge the flight battery.
	5. Store the flight battery apart from the aircraft and monitor the battery charge.
	6. Make note of the flight conditions and flight plan results, planning for future flights.

Troubleshooting Guide

AS3X

Problem	Possible Cause	Solution
Control surfaces not at neutral position when transmitter controls are at neutral	Control surfaces may not have been mechanically centered from factory	Center control surfaces mechanically by adjusting the U-bends on control linkages
	Aircraft was moved after the flight battery was connected and before sensors initialized	Disconnect and reconnect the flight battery while keeping the aircraft still for 5 seconds
Model flies inconsistently from flight to flight	Trims are moved too far from neutral position	Neutralize trims and mechanically adjust linkages to center control surfaces
Controls oscillate in flight, (model rapidly jumps or moves)	Propeller is unbalanced, causing excessive vibration	Remove propeller and rebalance or replace it if damaged
	Prop screw is too loose, causing vibration	Tighten the prop screw

Problem	Possible Cause	Solution
Aircraft will not respond to throttle but responds to other controls	Throttle stick and/or throttle trim is too high	Reset controls with throttle stick and throttle trim at lowest setting
	Throttle channel is reversed	Reverse throttle channel on transmitter
	Motor is disconnected from receiver	Open fuselage and ensure the plug for the motor is properly installed
Extra propeller noise or extra vibration	Damaged propeller, spinner or motor	Replace damaged parts
	Prop screw is too loose	Tighten the prop screw
Reduced flight time or aircraft underpowered	Flight battery charge is low	Completely recharge flight battery
	Propeller is installed backwards	Install propeller with numbers facing forward
	Flight battery is damaged	Replace flight battery and follow flight battery instructions
	Flight conditions may be too cold	Make sure battery is warm before use
	Battery capacity is too low for flight conditions	Replace battery or use a larger capacity battery

Troubleshooting Guide (continued)

Problem	Possible Cause	Solution
LED on receiver flashes rapidly and aircraft will not bind to transmitter (during binding)	Transmitter is too near aircraft during binding process	Power off transmitter, move transmitter a larger distance from aircraft, disconnect and reconnect flight battery to aircraft and follow binding instructions
	Bind switch or button was not held while transmitter was powered on	Power off transmitter and repeat bind process
	Aircraft or transmitter is too close to large metal object, wireless source or another transmitter	Move aircraft and transmitter to another location and attempt binding again
LED on receiver flashes rapidly and aircraft will not respond to transmitter (after binding)	Less than a 5-second wait between first powering on transmitter and connecting flight battery to aircraft	Leaving transmitter on, disconnect and reconnect flight battery to aircraft
	Aircraft is bound to a different model memory (ModelMatch™ radios only)	Select correct model memory on transmitter and disconnect and reconnect flight battery to aircraft
	Flight battery/transmitter battery charge is too low	Replace/recharge batteries
	Transmitter may have been bound to a different model (or with a different DSM Protocol)	Select the right transmitter or bind to the new one
	Aircraft or transmitter is too close to large metal object, wireless source or another transmitter	Move aircraft and transmitter to another location and attempt connecting again
Control surface does not move	Control surface, control horn, linkage or servo damage	Replace or repair damaged parts and adjust controls
	Wire damaged or connections loose	Do a check of wires and connections; connect or replace as needed
	Flight battery charge is low	Fully recharge flight battery
	Control linkage does not move freely	Make sure control linkage moves freely
Controls reversed	Transmitter settings reversed	Do the Control Direction Test and adjust controls on transmitter appropriately
Motor loses power	Damage to motor or power components	Do a check of motor and power components for damage (replace as needed)
Motor power quickly decreases and increases then motor loses power	Battery power is down to the point of receiver/ESC Low Voltage Cutoff (LVC)	Recharge flight battery or replace battery that is no longer performing
Servo locks or freezes at full travel	Travel adjust value is set above 100% overdriving the servo	Set Travel adjust to 100% or less and/or set sub trims to Zero and adjust linkages mechanically
Motor/ESC will not operate after crash landing	OCP stops motor when propeller is obstructed from movement	Fully lower throttle to allow operation
Receiver/motor will not function	Internal electronics are wet	Allow electronics to completely dry. If they still do not function, replace as needed.

Limited Warranty

What this Warranty Covers

Horizon Hobby, Inc. ("Horizon") warrants to the original purchaser that the product purchased (the "Product") will be free from defects in materials and workmanship at the date of purchase.

What is Not Covered

This warranty is not transferable and does not cover (i) cosmetic damage, (ii) damage due to acts of God, accident, misuse, abuse, negligence, commercial use, or due to improper use, installation, operation or maintenance, (iii) modification of or to any part of the Product, (iv) attempted service by anyone other than a Horizon Hobby authorized service center, (v) Product not purchased from an authorized Horizon dealer, or (vi) Product not compliant with applicable technical regulations.

OTHER THAN THE EXPRESS WARRANTY ABOVE, HORIZON MAKES NO OTHER WARRANTY OR REPRESENTATION, AND HEREBY DISCLAIMS ANY AND ALL IMPLIED WARRANTIES, INCLUDING, WITHOUT LIMITATION, THE IMPLIED WARRANTIES OF NON-INFRINGEMENT, MERCHANTABILITY AND FITNESS FOR A PARTICULAR PURPOSE. THE PURCHASER ACKNOWLEDGES THAT THEY ALONE HAVE DETERMINED THAT THE PRODUCT WILL SUITABLY MEET THE REQUIREMENTS OF THE PURCHASER'S INTENDED USE.

Purchaser's Remedy

Horizon's sole obligation and purchaser's sole and exclusive remedy shall be that Horizon will, at its option, either (i) service, or (ii) replace, any Product determined by Horizon to be defective. Horizon reserves the right to inspect any and all Product(s) involved in a warranty claim. Service or replacement decisions are at the sole discretion of Horizon. Proof of purchase is required for all warranty claims. SERVICE OR REPLACEMENT AS PROVIDED UNDER THIS WARRANTY IS THE PURCHASER'S SOLE AND EXCLUSIVE REMEDY.

Limitation of Liability

HORIZON SHALL NOT BE LIABLE FOR SPECIAL, INDIRECT, INCIDENTAL OR CONSEQUENTIAL DAMAGES, LOSS OF PROFITS OR PRODUCTION OR COMMERCIAL LOSS IN ANY WAY, REGARDLESS OF WHETHER SUCH CLAIM IS BASED IN CONTRACT, WARRANTY, TORT, NEGLIGENCE, STRICT LIABILITY OR ANY OTHER THEORY OF LIABILITY, EVEN IF HORIZON HAS BEEN ADVISED OF THE POSSIBILITY OF SUCH DAMAGES. Further, in no event shall the liability of Horizon exceed the individual price of the Product on which liability is asserted. As Horizon has no control over use, setup, final assembly, modification or misuse, no liability shall be assumed nor accepted for any resulting damage or injury. By the act of use, setup or

assembly, the user accepts all resulting liability. If you as the purchaser or user are not prepared to accept the liability associated with the use of the Product, purchaser is advised to return the Product immediately in new and unused condition to the place of purchase.

Law

These terms are governed by Illinois law (without regard to conflict of law principals). This warranty gives you specific legal rights, and you may also have other rights which vary from state to state. Horizon reserves the right to change or modify this warranty at any time without notice.

WARRANTY SERVICES

Questions, Assistance, and Services

Your local hobby store and/or place of purchase cannot provide warranty support or service. Once assembly, setup or use of the Product has been started, you must contact your local distributor or Horizon directly. This will enable Horizon to better answer your questions and service you in the event that you may need any assistance. For questions or assistance, please visit our website at www.horizonhobby.com, submit a Product Support Inquiry, or call the toll free telephone number referenced in the Warranty and Service Contact Information section to speak with a Product Support representative.

Inspection or Services

If this Product needs to be inspected or serviced and is compliant in the country you live and use the Product in, please use the Horizon Online Service Request submission process found on our website or call Horizon to obtain a Return Merchandise Authorization (RMA) number. Pack the Product securely using a shipping carton. Please note that original boxes may be included, but are not designed to withstand the rigors of shipping without additional protection. Ship via a carrier that provides tracking and insurance for lost or damaged parcels, as Horizon is not responsible for merchandise until it arrives and is accepted at our facility. An Online Service Request is available at http://www.horizonhobby.com/content/_service-center_render-service-center. If you do not have internet access, please contact Horizon Product Support to obtain a RMA number along with instructions for submitting your product for service. When calling Horizon, you will be asked to provide your complete name, street address, email address and phone number where you can be reached during business hours. When sending product into Horizon, please include your RMA number, a list of the included items, and a brief summary of the problem. A copy of your original sales receipt must be included for warranty consideration. Be sure your name,

address, and RMA number are clearly written on the outside of the shipping carton.

NOTICE: Do not ship LiPo batteries to Horizon. If you have any issue with a LiPo battery, please contact the appropriate Horizon Product Support office.

Warranty Requirements

For Warranty consideration, you must include your original sales receipt verifying the proof-of-purchase date. Provided warranty conditions have been met, your Product will be serviced or replaced free of charge. Service or replacement decisions are at the sole discretion of Horizon.

Non-Warranty Service

Should your service not be covered by warranty, service will be completed and payment will be required without notification or estimate of the expense unless the expense exceeds 50% of the retail purchase cost. By submitting the item for service you are agreeing to payment of the service without notification.

Service estimates are available upon request. You must include this request with your item submitted for service. Non-warranty service estimates will be billed a minimum of ½ hour of labor. In addition you will be billed for return freight. Horizon accepts money orders and cashier's checks, as well as Visa, MasterCard, American Express, and Discover cards. By submitting any item to Horizon for service, you are agreeing to Horizon's Terms and Conditions found on our website http://www.horizonhobby.com/content/_service-center_render-service-center.

ATTENTION: Horizon service is limited to Product compliant in the country of use and ownership. If received, a non-compliant Product will not be serviced. Further, the sender will be responsible for arranging return shipment of the un-serviced Product, through a carrier of the sender's choice and at the sender's expense. Horizon will hold non-compliant Product for a period of 60 days from notification, after which it will be discarded.

Warranty and Service Information

Country of Purchase	Horizon Hobby	Phone Number/Email Address	Address
United States of America	Horizon Service Center (Repairs and Repair Requests)	servicecenter.horizonhobby.com/RequestForm/	4105 Fieldstone Rd Champaign, Illinois 61822 USA
	Horizon Product Support (Product Technical Assistance)	www.quickbase.com/db/bgjh7ey8c?a=GenNewRecord 888-959-2305	
	Sales	sales@horizonhobby.com 888-959-2305	
United Kingdom	Service/Parts/Sales: Horizon Hobby Limited	sales@horizonhobby.co.uk +44 (0) 1279 641 097	Units 1-4 , Ployters Rd, Staple Tye Harlow, Essex, CM18 7NS, United Kingdom
Germany	Horizon Technischer Service	service@horizonhobby.de	Christian-Junge-Straße 1 25337 Elmshorn, Germany
	Sales: Horizon Hobby GmbH	+49 (0) 4121 2655 100	
France	Service/Parts/Sales: Horizon Hobby SAS	infofrance@horizonhobby.com +33 (0) 1 60 18 34 90	11 Rue Georges Charpak 77127 Lieusaint, France
China	Service/Parts/Sales: Horizon Hobby – China	info@horizonhobby.com.cn +86 (021) 5180 9868	Room 506, No. 97 Changshou Rd. Shanghai, China 200060

Compliance Information for the European Union

Declaration of Conformity

(in accordance with ISO/IEC 17050-1)

No. HH2013072402

Product(s): PKZ UMS Icon A5 BNF

Item Number(s): PKZU2380

Equipment class: 1

The object of declaration described above is in conformity with the requirements of the specifications listed below, following the provisions of the European R&TTE directive 1999/5/EC, EMC Directive 2004/108/EC and LVD Directive 2006/95/EC

EN 301 489-1 V1.9.2: 2012

EN 301 489-17 V2.1.1: 2009

EN60950-1:2006+A11:2009+A1:2010+A12: 2011

EN55022:2010 + AC:2011

EN55024: 2010



Signed for and on behalf of:
Horizon Hobby, Inc.
Champaign, IL USA
July 24, 2013

Robert. Peak
Chief Financial Officer
Horizon Hobby, Inc.



Instructions for disposal of WEEE by users in the European Union

This product must not be disposed of with other waste. Instead, it is the user's responsibility to dispose of their waste equipment by handing it over to a designated collections point for the recycling of waste electrical and electronic equipment. The separate collection and recycling of your waste equipment at the time of disposal will help to conserve natural resources and ensure that it is recycled in a manner that protects human health and the environment. For more information about where you can drop off your waste equipment for recycling, please contact your local city office, your household waste disposal service or where you purchased the product.

Replacement Parts • Ersatzteile • Pièces de rechange • Pezzi di ricambio

Part # • Nummer Numéro • Codice	Description	Beschreibung	Description	Descrizione
EFLUP1001003B	100 x 100mm 3 Blade Propeller	100 x 100mm 3Blattpropeller	Hélice 3 pales 100 x 100mmmm	Elica 3 pale 100x 100mm mm
PKZU2308	Spinner Set (3): UM Icon A5	UM Icon A5: Spin- ner Set (3)	Set de cônes (3): UM Icon A5	Set ogiva (3): UM Icon A5
PKZU2370	Ultra Micro Civil- ian Pilot	Ultra Micro Zivil- pilot	Pilote civil: UM Icon A5	Pilota civile Ultra Micro
PKZU2367	Fuselage w/hatch and pilot: UM Icon A5	UM Icon A5: Rumpf m. Haube u. Pilot	Fuselage avec bulle et pilote: UM Icon A5	Fusoliera con capot- tina e pilota: UM Icon A5
PKZU2305	Canopy Hatch: UM Icon A5	UM Icon A5: Kabi- nenhaube	Bulle : UM Icon A5	Capottina: UM Icon A5
PKZU2320	Main Wing: UM Icon A5	UM Icon A5: Tragfläche	Aile: UM Icon A5	Ala Principale: UM Icon A5
PKZU2325	Complete Tail w/ Accessories: UM Icon A5	UM Icon A5: Leitwerk m. Zbh.	Stabilisateur complet avec accessoires : UM Icon A5	Coda completa di accessori: UM Icon A5
PKZU2303	Landing Gear Set: UM Icon A5	Fahrgestellsatz: UM Icon A5	Jeu de train d'atterrissage : UM Icon A5	Set carrello di atterraggio: UM Icon A5
PKZU2326	Pushrod Set: UM Icon A5	UM Icon A5: Schubstangensatz	Jeu tringleries : UM Icon A5	Set asta di spinta: UM Icon A5
PKZU2302	Decal Sheet: UM Icon A5	Parkzone UM Icon A5: Dekorbogen	Planche de décalcomanies : UM Icon A5	Foglio con decalcomanie: UM Icon A5
EFLB1802S20	2S 7.4V 20C 180mAh Li-Po Battery	2S-7,4V-20C 180mAh-Li-Po-Akku	Batterie Li-Po 180 mAh 20C 7,4V 2S	Batteria Li-Po 2S da 7,4V, 20C 180 mAh
EFLUC1007	Celectra 2S 7,4 V DC Li-Po Charger	Celectra 2S 7,4 V DCLi-Po Ladegerät	Chargeur Celectra DC 7,4V 2S	Celectra 2S 7,4 V DC Caricabatterie Li-Po
EFLUC1008	Power Cord for EFLUC1007	Anschlußstecker mit Krokodilklemmen für EFLUC1007	Câble d'alimentation EFLUC1007	Cavo alimentazioneper EFLUC1007
SPMAS6410NBL	DSM2/DSMX UM 6-Channel AS3X Receiver/ESC	DSM2/X 6 Kanal UM AS3X Empfänger/ Regler	Module RX 6voies/ AS3X/ESC	Ricevitore/ESC DSM2/X 6 ch UM AS3X
SPMSA2030L	2.3-Gram Performance Linear Long Throw Servo	Spektrum 2,3-Gramm Performance Linear Servo m. langem Ruderweg	Servo 2.3g linéaire longue course performant	Ottimo servo lineare a corsa lunga da 2,3 Grammi
SPMSA2030LO	2.3-Gram Linear Long Throw Offset Servo (Ailerons)	2,3 Gramm Linear Offset Servo (Querruder)	Servo linéaire offset course longue 2,3 g (Ailerons)	Servo di offset corsa lunga lineari a prestazioni elevate da 2,3 grammi (Alettoni)
SPM6836	Replacement Servo Mechanics: 2.3- Gram 2030L	Spektrum Ersatzgetriebe Servo: 2.3-Gramm 2030L	Mécanique de servo servo : 2.3g 2030L	Servo di ricambio Meccanica: 2.3- Gram 2030L

Part # • Nummer Numéro • Codice	Description	Beschreibung	Description	Descrizione
EFLUM180BL2	180 Brushless Outrunner Motor 2500Kv	180 Brushless Outrunner Motor 2500Kv	Moteur à cage tournante sans balai 180, 2500 Kv	Motore outrunner brushless 180 da 2.500 Kv
EFLU4167	Prop Adapter: UMX Sbach	Parkzone Propeller Adapter: UMX Sbach 342	Adaptateur d'hélice: UMX Sbach	Adattatore elica: UMX Sbach

Optional Parts and Accessories • Optionale Bauteile und Zubehör • Pièces et accessoires optionnels • Componenti e accessori opzionali

Part # Nummer Numéro Codice	Description	Beschreibung	Description	Descrizione
EFLA700UM	Charger Plug Adapter EFL	E-flite Ladekabel Adapter EFL	Adaptateur de charge EFL	Adattatore spina caricatore EFL
EFLA7001UM	Charger Plug Adapter THP	E-flite Ladekabel Adapter TP	Adaptateur de charge THP	Adattatore spina caricatore THP
EFLC3025	Celectra 80W AC/ DC Multi-Chem- istry Battery Charger	E-flite 80W AC/ DC Multi-Akku Ladegerät - EU	Chargeur Celectra 80W AC/DC	Celectra 80W AC/DC Caricatore multiplo
EFLA111	Li-Po Cell Voltage Checker	E-flite Li-Po Cell Volt Checker	Contrôleur de tension Li-Po	Tester tensione bat- terie LiPo
EFLC4000/AU/ EU/UK	AC to 12V DC 1.5 amp Power Supply (Based upon your sales Region)	AC zu 12V DC 1,5 Ampere Netz- stecker (Basierend nach Vertriebsregion)	Alimentation CA vers 12 V CC, 1,5 A (En fonc- tion de votre région)	Alimentatore da CA a 12 V CC, 1,5 Amp (in base al Paese di vendita)
	DX4e DSMX 4-channel Transmitter	Spektrum DX4e DSMX 4 Kanalsender ohne Empfänger	Emetteur DX4e DSMX 4 voies	DX4e DSMX Trasmettitore 4 canali
	DX5e DSMX 5-channel Transmitter	Spektrum DX5e DSMX 5 Ka- nalsender ohne Empfänger	Emetteur DX5e DSMX 5 voies	DX5e DSMX Trasmettitore 5 canali
	DX6i DSMX 6-Channel Trans- mitter	DX6i DSMX 6-Kanal Sender	Emetteur DX6i DSMX 6 voies	DX6i DSMX Trasmettitore 6 canali
	DX7s DSMX 7-Channel Transmitter	Spektrum DX7s 7 Kanal Sender	Emetteur DX7s DSMX 7 voies	DX7s DSMX Trasmettitore 7 canali
	DX8 DSMX Transmitter	Spektrum DX8 nur Sender	Emetteur DX8 DSMX 8 voies	DX8 DSMX Solo trasmettitore

© 2013 Horizon Hobby, Inc.

ParkZone, AS3X, Blade, E-flite, Celectra, DSM, DSM2, DSMX, Bind-N-Fly and ModelMatch are trademarks or registered trademarks of Horizon Hobby, Inc.

The Spektrum trademark is used with permission of Bachmann Industries, Inc.

Futaba is a registered trademark of Futaba Denshi Kogyo Kabushiki Kaisha Corporation of Japan.

ICON, the ICON logo, ICON A5 and its body design are trademarks or registered trademarks of ICON Aircraft, Inc. and are used with permission by Horizon Hobby, Inc.

All other trademarks, service marks and logos are property of their respective owners.

US D578,146. US 7,898,130. PRC ZL 200720069025.2. Other patents pending.



parkzone[®]



www.parkzone.com
PKZU2480