



Fly First Class™

Pulse XT 60 ARF

ASSEMBLY MANUAL



Specifications

Wingspan..... 70 in (1778mm)
 Wing Area 885 sq in (5710 sq cm)
 Length..... 57.3 in (1455mm)
 Weight..... 7–8 lb (3.18 kg–3.63 kg)

Engine..... .91–1.00 Four-Stroke
60–.75 Two-Stroke
 Power 60 Electric
 Radio..... 4-Channel w/5 Servos (4 for electric)

Table of Contents

Using the Manual	3
Required Tools and Adhesives	3
UltraCote Covering Colors	3
Before Starting Assembly	3
Radio and Power Systems Requirements	4
Recommended Servo Extensions	4
Recommended JR, JR SPORT and Spektrum Systems	4
Recommended Setup—2-Stroke Glow	5
Recommended Setup—4-Stroke Glow	5
Recommended Setup—Electric	5
FS One	5
Field Equipment	5
Warranty Information	6
Contents of Kit / Replacement Parts	8
Section 1: Aileron Servo Installation	9
Section 2: Landing Gear Installation	15
Section 3: Rudder and Elevator Installation	18
Section 4: Glow Engine and Cowling Installation	24
Section 5: Electric Motor and Cowling Installation	33
Section 6: Receiver Installation	37
Section 7: Canopy and Wing Installation	38
Section 8: Control Throws	41
Section 9: Recommended Center of Gravity (CG)	42
Section 10: Pre-Flight	43
Section 11: Adjusting the Engine	43
Section 12: Range Testing Your Radio	43
2008 Official AMA National Model Aircraft Safety Code	44

Using the Manual

This manual is divided into sections to help make assembly easier to understand, and to provide breaks between each major section. In addition, check boxes have been placed next to each step to keep track of each step completed. Steps with a single box () are performed once, while steps with two boxes () indicate that the step will require repeating, such as for a right or left wing panel, two servos, etc. Remember to take your time and follow the directions.

Required Tools and Adhesives

Tools

- Felt-tipped pen or pencil
- Adjustable wrench
- Hobby knife
- Ruler
- Soldering iron
- Hex wrench: 3/32-inch, 7/64-inch
- Drill bit: 5/64-inch (2mm), 11/64-inch (4.5mm), 5/32-inch (4mm)
- Flat screwdriver
- Drill
- Masking tape
- Sandpaper
- Solder
- Phillips screwdriver: #1, #2

Adhesives

- Formula 560 Canopy Glue (PAAPT56)
- Thin CA (cyanoacrylate) Glue (PAAPT07)
- Pacer Z-42 Threadlock (PAAPT42)
- CA Remover/Debonder (PAAPT16)

UltraCote Covering Colors

- Black HANU874
- Cub Yellow HANU884
- True Red HANU866

Before Starting Assembly

Before beginning the assembly of the Pulse XT 60, remove each part from its bag for inspection. Closely inspect the fuselage, wing panels, rudder, and stabilizer for damage. If you find any damaged or missing parts, contact the place of purchase.

If you find any wrinkles in the covering, use a heat gun or sealing iron to remove them. Use caution while working around areas where the colors overlap to prevent separating the colors.



HAN101 – Sealing Iron

**HAN141 – Sealing Iron
Sock**



HAN100 – Heat Gun

HAN150 – Covering Glove

Radio and Power Systems Requirements

- 4-channel radio system (minimum) w/receiver
- 1500mAh Ni-MH 4-cell (JSP91030)
- JR Standard Switch (JSP98010) or JR Chargeswitch (JRPA004)
- DS821 Digital Sport Servo (JRPS821) (5) or equivalent (4 when building electric version)
- In-line fuel filter (DUB340)
- 1/4-inch Protective Foam (for receiver) (DUB513)

Recommended Servo Extensions

4-channel Radio System

Aileron

Y-harness (JSP98020)

6-inch Servo Extension JSP98110 (2)

5-channel Radio System

Aileron

3-inch Servo Extension JSP98100 (2)

6-inch Servo Extension JSP98110 (2)

Recommended JR, JR SPORT and Spektrum Systems

- X9303 2.4
- XP9303
- XP7202
- XP6102
- DX7
- DX6i



JR XP7202



JR XP6102



Spektrum DX7



JR X9303 2.4



Spektrum DX6i

Spektrum is used with permission of
Bachmann Industries, Inc.

Recommended Setup—2-Stroke Glow

- Evolution® .61NT with Muffler (EVOE0610)
- Evolution Propeller: 11 x 7, 12 x 6 (EVO11070, EVO12060))



**Evolution .61NT
EVOE0610**

Recommended Setup—4-Stroke Glow

- Saito™ 1.00 AAC w/Muffler (SAIE100 or SAIE100GK)
- Evolution Propeller: 14 x 8 (EVO14080)



**Saito 1.00 AAC
SAIE100**

Recommended Setup—Electric

- E-flite® Power 60 BL Outrunner Motor (EFLM4060A)
- 60-Amp Pro Switch-Mode BEC Brushless ESC (EFLA1060)
- Thunder Power 6S 3850–5000mAh Li-Po battery pack
- APC Propeller: 16 x 8 (APC16080E)



**Power 60 Brushless
Outrunner Motor, 400Kv
EFLM4060A**

FS One

With FS One® you get more than photorealistic fields, gorgeous skies and realistic-looking aircraft. You get incredibly advanced aerodynamic modeling that simulates every possible aspect of real-world flight.



HANS2000



HANS4010

Field Equipment

- Propeller
- Glow Plug Wrench (HAN2510)
- Glow Plug (EVOGP1)
- Flight Pack Field Box (HAN130)
- Mosfet Power Panel (HAN106)
- Fuel
- Extra Long Glow Plug Igniter w/Charger (HAN7115)
- Manual Fuel Pump (HAN118)
- PowerPro HD 12V Starter (HAN162)
- 12-volt 7Ah Sealed Battery (HAN102)

Warranty Information

Warranty Period

Exclusive Warranty- Horizon Hobby, Inc., (Horizon) warrants that the Products purchased (the "Product") will be free from defects in materials and workmanship at the date of purchase by the Purchaser.

Limited Warranty

(a) This warranty is limited to the original Purchaser ("Purchaser") and is not transferable. REPAIR OR REPLACEMENT AS PROVIDED UNDER THIS WARRANTY IS THE EXCLUSIVE REMEDY OF THE PURCHASER. This warranty covers only those Products purchased from an authorized Horizon dealer. Third party transactions are not covered by this warranty. Proof of purchase is required for warranty claims. Further, Horizon reserves the right to change or modify this warranty without notice and disclaims all other warranties, express or implied.

(b) Limitations- HORIZON MAKES NO WARRANTY OR REPRESENTATION, EXPRESS OR IMPLIED, ABOUT NON-INFRINGEMENT, MERCHANTABILITY OR FITNESS FOR A PARTICULAR PURPOSE OF THE PRODUCT. THE PURCHASER ACKNOWLEDGES THAT THEY ALONE HAVE DETERMINED THAT THE PRODUCT WILL SUITABLY MEET THE REQUIREMENTS OF THE PURCHASER'S INTENDED USE.

(c) Purchaser Remedy- Horizon's sole obligation hereunder shall be that Horizon will, at its option, (i) repair or (ii) replace, any Product determined by Horizon to be defective. In the event of a defect, these are the Purchaser's exclusive remedies. Horizon reserves the right to inspect any and all equipment involved in a warranty claim. Repair or replacement decisions are at the sole discretion of Horizon. This warranty does not cover cosmetic damage or damage due to acts of God, accident, misuse, abuse, negligence, commercial use, or modification of or to any part of the Product. This warranty does not cover damage due to improper installation, operation, maintenance, or attempted repair by anyone other than Horizon. Return of any goods by Purchaser must be approved in writing by Horizon before shipment.

Damage Limits

HORIZON SHALL NOT BE LIABLE FOR SPECIAL, INDIRECT OR CONSEQUENTIAL DAMAGES, LOSS OF PROFITS OR PRODUCTION OR COMMERCIAL LOSS IN ANY WAY CONNECTED WITH THE PRODUCT, WHETHER SUCH CLAIM IS BASED IN CONTRACT, WARRANTY, NEGLIGENCE, OR STRICT LIABILITY. Further, in no event shall the liability of Horizon exceed the individual price of the Product on which liability is asserted. As Horizon has no control over use, setup, final assembly, modification or misuse, no liability shall be assumed nor accepted for any resulting damage or injury. By the act of use, setup or assembly, the user accepts all resulting liability.

If you as the Purchaser or user are not prepared to accept the liability associated with the use of this Product, you are advised to return this Product immediately in new and unused condition to the place of purchase.

Law: These Terms are governed by Illinois law (without regard to conflict of law principals).

Safety Precautions

This is a sophisticated hobby Product and not a toy. It must be operated with caution and common sense and requires some basic mechanical ability. Failure to operate this Product in a safe and responsible manner could result in injury or damage to the Product or other property. This Product is not intended for use by children without direct adult supervision. The Product manual contains instructions for safety, operation and maintenance. It is essential to read and follow all the instructions and warnings in the manual, prior to assembly, setup or use, in order to operate correctly and avoid damage or injury.

Questions, Assistance, and Repairs

Your local hobby store and/or place of purchase cannot provide warranty support or repair. Once assembly, setup or use of the Product has been started, you must contact Horizon directly. This will enable Horizon to better answer your questions and service you in the event that you may need any assistance. For questions or assistance, please direct your email to productsupport@horizonhobby.com, or call 877.504.0233 toll free to speak to a service technician.

Inspection or Repairs

If this Product needs to be inspected or repaired, please call for a Return Merchandise Authorization (RMA). Pack the Product securely using a shipping carton. Please note that original boxes may be included, but are not designed to withstand the rigors of shipping without additional protection. Ship via a carrier that provides tracking and insurance for lost or damaged parcels, as **Horizon is not responsible for merchandise until it arrives and is accepted at our facility**. A Service Repair Request is available at www.horizonhobby.com on the "Support" tab. If you do not have internet access, please include a letter with your complete name, street address, email address and phone number where you can be reached during business days, your RMA number, a list of the included items, method of payment for any non-warranty expenses and a brief summary of the problem. Your original sales receipt must also be included for warranty consideration. Be sure your name, address, and RMA number are clearly written on the outside of the shipping carton.

Warranty Inspection and Repairs

To receive warranty service, you must include your original sales receipt verifying the proof-of-purchase date. Provided warranty conditions have been met, your Product will be repaired or replaced free of charge. Repair or replacement decisions are at the sole discretion of Horizon Hobby.

Non-Warranty Repairs

Should your repair not be covered by warranty the repair will be completed and payment will be required without notification or estimate of the expense unless the expense exceeds 50% of the retail purchase cost. By submitting the item for repair you are agreeing to payment of the repair without notification. Repair estimates are available upon request. You must include this request with your repair. Non-warranty repair estimates will be billed a minimum of ½ hour of labor. In addition you will be billed for return freight. Please advise us of your preferred method of payment. Horizon accepts money orders and cashiers checks, as well as Visa, MasterCard, American Express, and Discover cards. If you choose to pay by credit card, please include your credit card number and expiration date. Any repair left unpaid or unclaimed after 90 days will be considered abandoned and will be disposed of accordingly. **Please note: non-warranty repair is only available on electronics and model engines.**

Electronics and engines requiring inspection or repair should be shipped to the following address:

Horizon Service Center
4105 Fieldstone Road
Champaign, Illinois 61822

All other Products requiring warranty inspection or repair should be shipped to the following address:

Horizon Product Support
4105 Fieldstone Road
Champaign, Illinois 61822

Please call 877-504-0233 with any questions or concerns regarding this product or warranty.

Safety, Precautions, and Warnings

This model is controlled by a radio signal that is subject to interference from many sources outside your control. This interference can cause momentary loss of control so it is advisable to always keep a safe distance in all directions around your model, as this margin will help to avoid collisions or injury.

- Always operate your model in an open area away from cars, traffic, or people.
- Avoid operating your model in the street where injury or damage can occur.
- Never operate the model into the street or populated areas for any reason.
- Never operate your model with low transmitter batteries.
- Carefully follow the directions and warnings for this and any optional support equipment (chargers, rechargeable battery packs, etc.) that you use.
- Keep all chemicals, small parts and anything electrical out of the reach of children.
- Moisture causes damage to electronics. Avoid water exposure to all equipment not specifically designed and protected for this purpose.

Contents of Kit / Replacement Parts

A. HAN4131	Fuselage w/Hatch	L. HAN4142	2 ⁷ / ₁₆ -inch (62mm) EP Motor Mounts
B. HAN4132	Left Wing Panel w/Aileron	M. HAN4144	2 ¹ / ₄ -inch (57mm) Yellow Spinner
C. HAN4133	Right Wing Panel w/Aileron	N. HAN1987	17 oz (500cc) Fuel Tank
D. HAN4134	Stabilizer and Elevator	O. HAN90M	Nylon Engine Mount 90–125
E. HAN4135	Fin and Rudder	P. HAN305	2 ³ / ₄ -inch (70mm) Pro-Lite wheels
F. HAN4136	Tinted Canopy		
G. HAN4137	Fiberglass Painted Cowl		
H. HAN4138	Fiberglass Paint Wheel Pants		
I. HAN4139	Aluminum Landing Gear w/o Wheels	Not Shown	
J. HAN4140	Anodized Aluminum Wing Tube	HAN4143	Decal Set
K. HAN4141	Pushrod Set	HAN4709	Tail wheel assembly w/1-inch (25mm) wheel

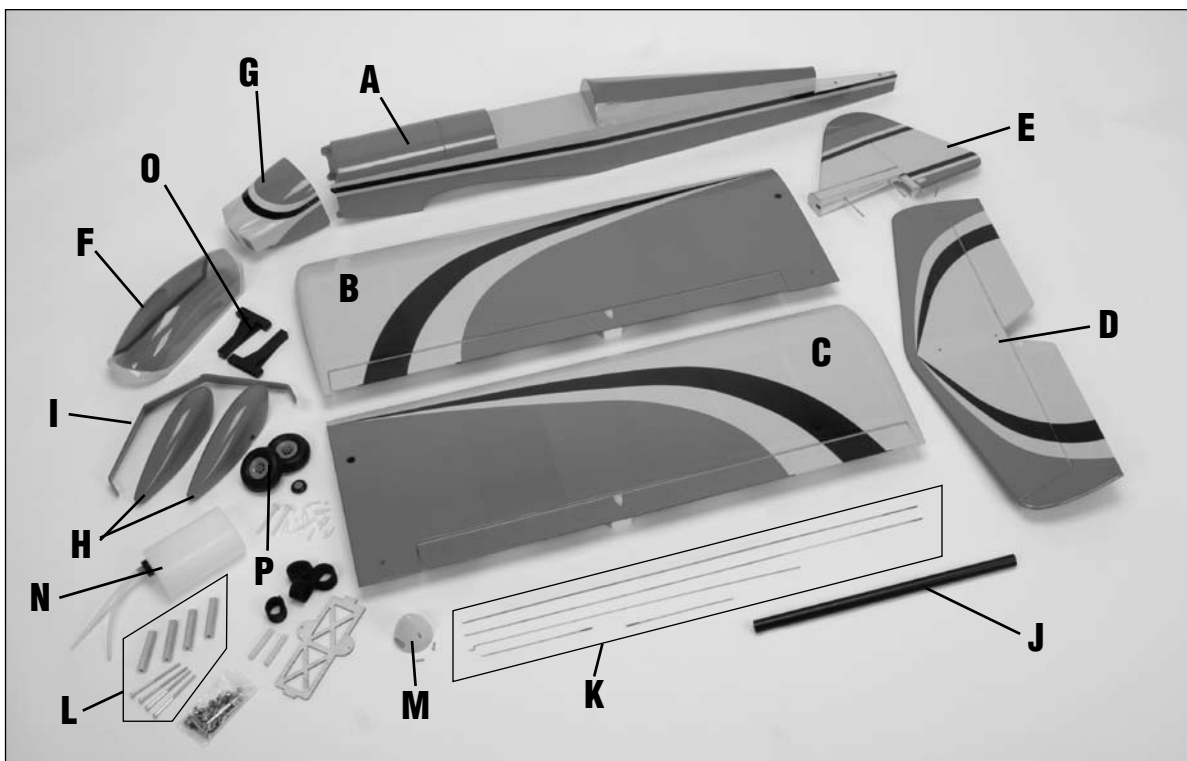

Section 1: Aileron Servo Installation

Required Parts

- Wing panel w/ailerons (right and left)
- Servo w/hardware (2)
- 6 1/4-inch (89mm) aileron linkage (2)

Required Tools and Adhesives

- Drill
- Thin CA
- Phillips screwdriver
- 180-degree servo arm
- Drill bit: 5/64-inch (2mm)

□□ Step 1a

Check to make sure the hinges have been securely glued into place. Gently pull on each aileron to make sure the hinges are secure. Avoid too much pressure which could cause damage to the wing and aileron.



□□ Step 1b

If any hinges are found to be loose, apply thin CA to the top and bottom of the loose hinge to secure its position.



□□ Step 2

Flex each aileron up and down a number of times to break in the hinges.

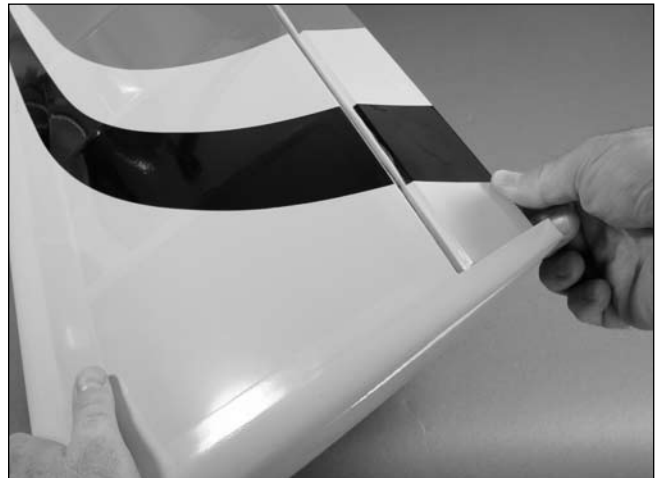

Note: Do not use accelerator when gluing hinges. The CA must be allowed to cure naturally so it can soak into the hinge,

Section 1: Aileron Servo Installation

□□ Step 3

Prepare the aileron servo by installing the grommets and brass eyelets provided with the servo. Plug the aileron servo into the receiver and use the radio system to center the servo. Install a 180-degree servo horn onto the aileron servo as shown.

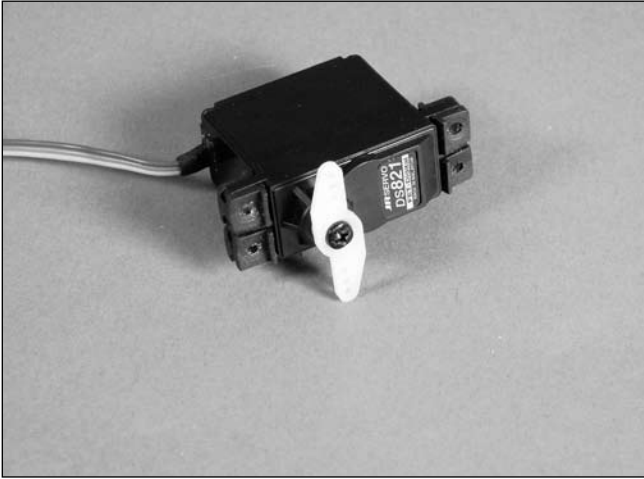

□□ Step 4

Use side cutters to remove one of the arms from the servo horn.

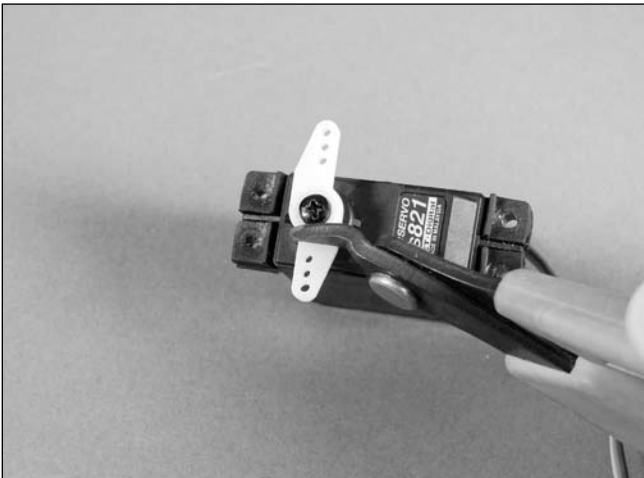

□□ Step 5

Use a 5/64-inch (2mm) drill bit to enlarge the outer hole of the servo arm.

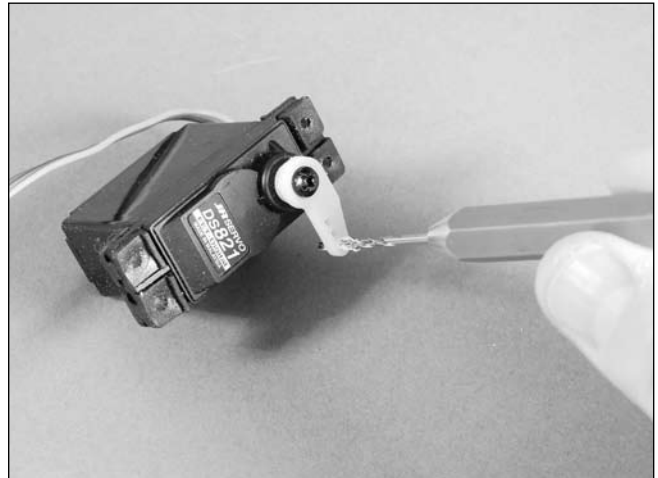

□□ Step 6

Secure a 6-inch (152mm) servo extension to the servo lead using a commercially available connector or string.

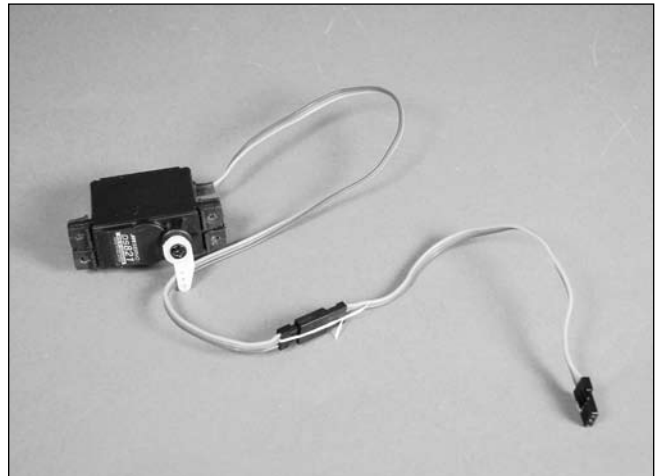

Section 1: Aileron Servo Installation

□ Step 7

Repeat Steps 3 through 7 to prepare a second aileron servo. Note the direction of the servo arm in relationship to the servo. You will be preparing a right and left aileron servo, which are mirror images of each other.

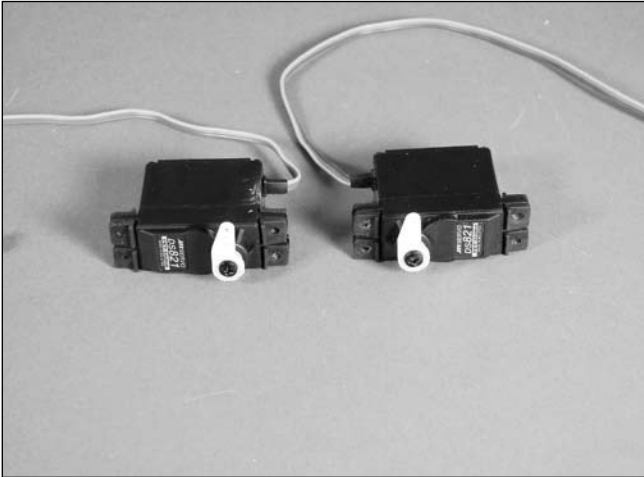

□□ Step 8

Thread one of the servo mounting screws into each of the pre-drilled holes for the aileron servo as shown. This will cut the threads into the wood in preparation for the following step.

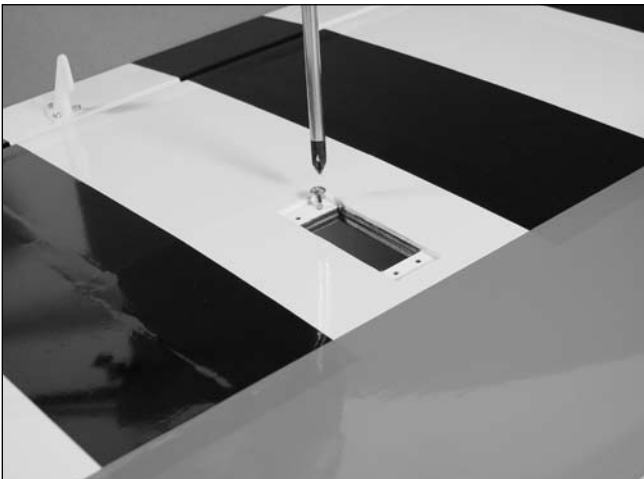

□□ Step 9

After cutting the threads into the wood, apply a few drops of thin CA to each of the four holes to harden the surrounding wood. This will provide a better surface for the screws and prevent vibration from loosening the screws in flight.



Section 1: Aileron Servo Installation

□□ Step 10

Tie a wheel collar to the end of a 12-inch (300mm) piece of string. Lower the wheel collar into the opening for the servo and allow it to fall through the wing, exiting the opening at the root of the wing as shown below.

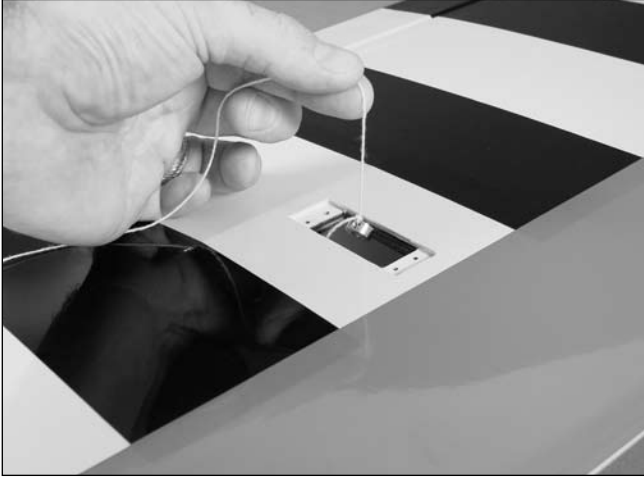

□□ Step 11

Tie the string that exits the servo opening to the servo extension. Use the string to pull the servo lead through the wing.

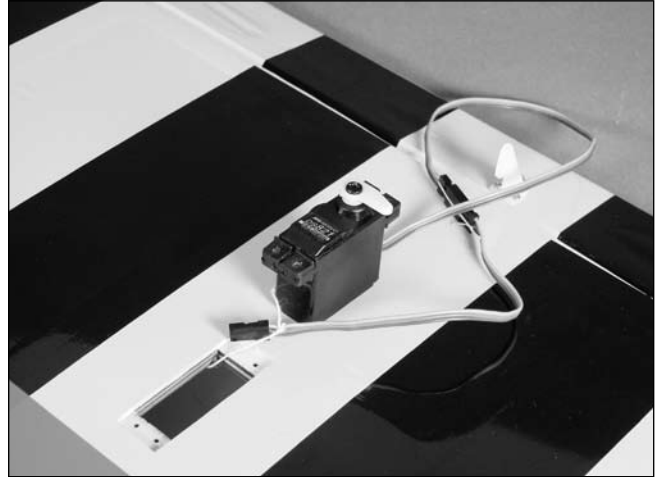

Hint: Use painter's tape to prevent the extension from falling back into the wing.

Section 1: Aileron Servo Installation

□□ Step 12

Secure the servo using the screws provided with the servo. The servo is positioned so the output of the servo faces the aileron, and the servo arm will face toward the wing tip.



□□ Step 13

Slide a clevis retainer onto one of the nylon clevises. Thread the clevis 14 turns onto the 6 ¹/₄-inch (160mm) threaded pushrod.

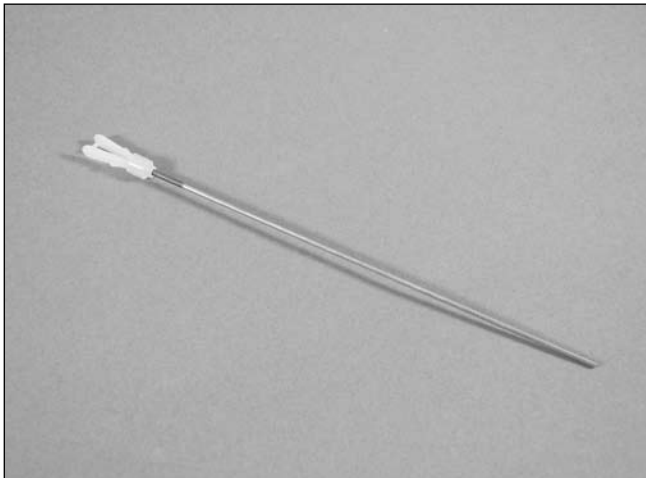

□□ Step 14

Attach the clevis to the center hole on the servo horn.



□□ Step 15

Center both the aileron servo and aileron. Use a felt-tipped pen to mark the pushrod where it crosses the outer hole of the servo arm.

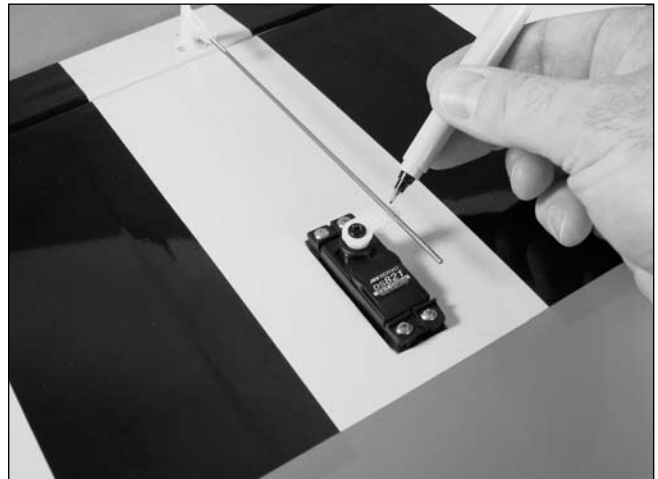

Section 1: Aileron Servo Installation

□□ Step 16

Use pliers to make a 90-degree bend at the mark made in the previous step.

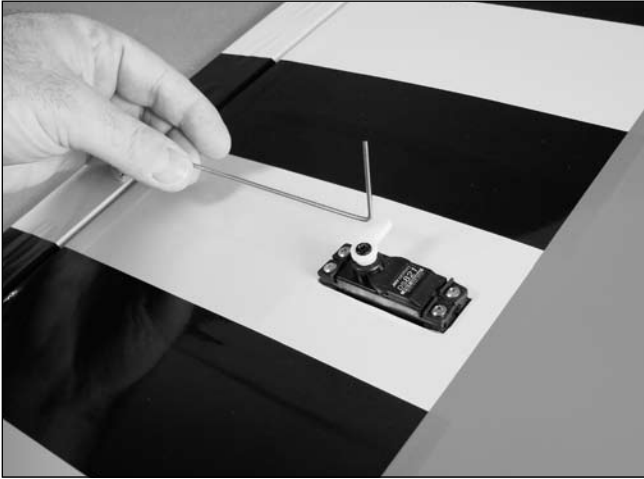

□□ Step 18

Use side cutters to trim the pushrod wire so only 1/16-inch (1.5mm) extends beyond the connector.

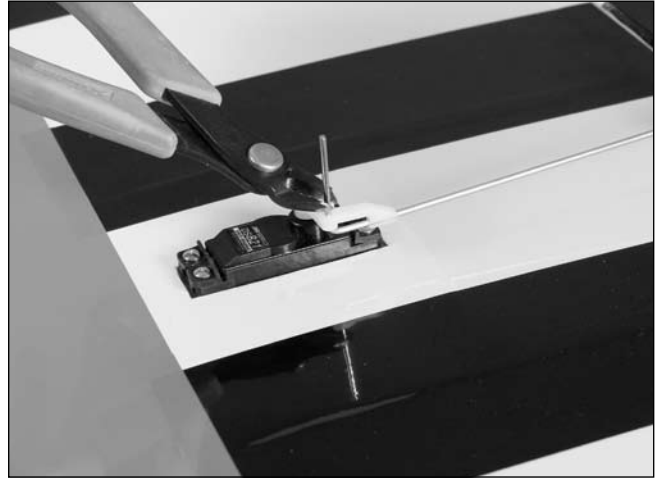

□□ Step 17

Secure the pushrod wire to the servo horn using a pushrod connector. The connector will slide onto the wire, then snap onto the wire under the servo arm.

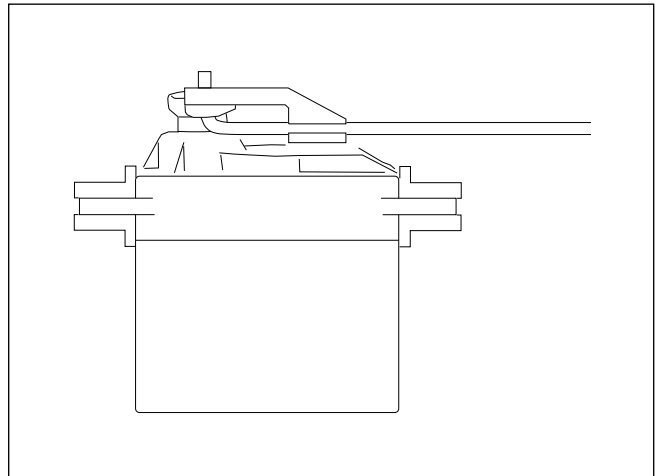
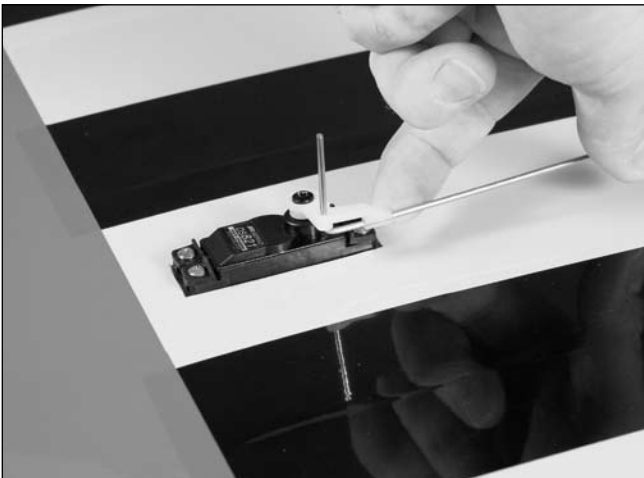

Hint: Use a flat file to remove any sharp edges at the end of the wire.

□ Step 19

Repeat Steps 8 through 18 for the remaining aileron servo and linkage.

Section 2: Landing Gear Installation

Required Parts

- Fuselage assembly
- Landing gear
- Wheel pant (left and right)
- Axle w/nut (2)
- 5/32-inch wheel collar w/setscrew (4)
- 1/16-inch wheel collar w/setscrew (2)
- Tail wheel, 1-inch (25mm)
- Main wheel, 2³/₄-inch (70mm) (2)

Required Tools and Adhesives

- Threadlock
- Adjustable wrench (2)
- Hex wrench: 3/32-inch, 7/64-inch
- Hex wrench: 1.5mm (supplied with kit)

□ Step 1

Attach the landing gear to the fuselage using two 6-32 x 1/2-inch socket head screws and two #6 washers. Note the landing gear is swept towards the rear of the fuselage as shown in the photo.

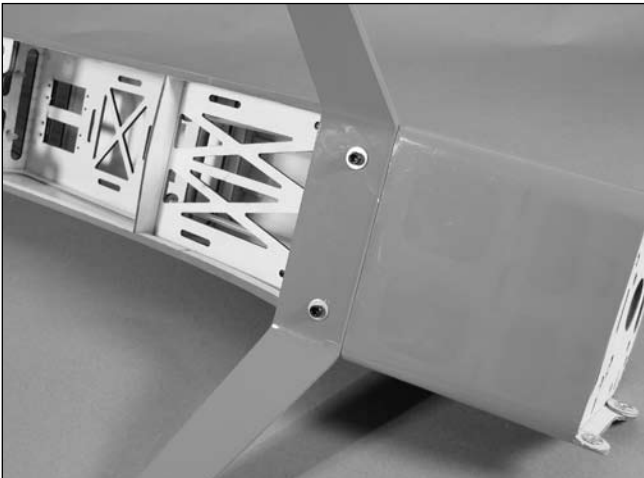

Note: Use threadlock on the screws to prevent them from vibrating loose in flight.

□□ Step 2

Use two adjustable wrenches to attach the axles to the landing gear.



□□ Step 3

Use a file to create a flat on the bottom of the axle. This will give the setscrews an area to bite into, helping prevent the loss of the wheel collars in flight.



Section 2: Landing Gear Installation

□□ Step 4

Secure one of the 5/32-inch wheel collars to the axle near the gear using a setscrew and the supplied hex wrench. The position of the wheel collar will be adjusted later in this section.



□□ Step 5

Slide the wheel onto the axle, then install a second wheel collar.



□□ Step 6

Slide the wheel pant over the axle and wheel. Use a 4-40 x 1/2-inch socket head screw and a #4 washer to secure the wheel pant to the landing gear.



Note: Use threadlock on the screws to prevent them from vibrating loose in flight.

□□ Step 7

Loosen the setscrews in the two wheel collars. Position the wheel so it is centered in the wheel pant, then use the wheel collars to secure the wheel. Make sure the wheel collars are not pressed too tightly against the wheel or it may not be able to roll freely.



Note: Use threadlock on the screws to prevent them from vibrating loose in flight.

□□ Step 8

Repeat Steps 2 through 7 for the remaining wheel and wheel pant installation.

Section 2: Landing Gear Installation

□ Step 9

The tail wheel follows the same procedure as the main wheels, except no wheel pant is involved. The two wheel collars used to secure the tail wheel are 1/16-inch.

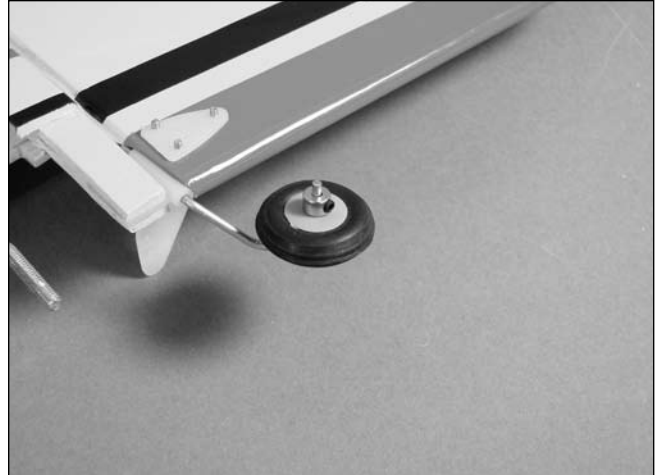
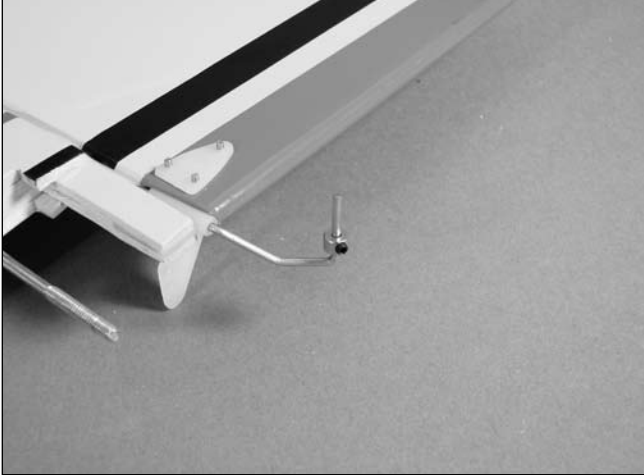

Note: Use threadlock on the setscrews to prevent them from vibrating loose in flight.

Section 3: Rudder and Elevator Installation

Required Parts

- Fuselage assembly
- Servo (2)
- 180-degree servo horn (2)
- 27 1/2-inch (698mm) threaded pushrod (2)

Required Tools and Adhesives

- Screwdriver: #1 Phillips
- Pin drill
- Drill bit: 5/64-inch (2mm)
- Threadlock
- Adjustable wrench

Step 1

Locate the rudder/fin and stabilizer/elevator. Check the hinges as described in Section 1, Steps 1 and 2.

Step 2

Place the stabilizer/elevator in position at the rear of the fuselage. Align the holes in the stabilizer with the holes in the fuselage.



Step 3

Slide the threaded studs from the fin into the holes in the stabilizer. The studs will then go through the holes in the fuselage.

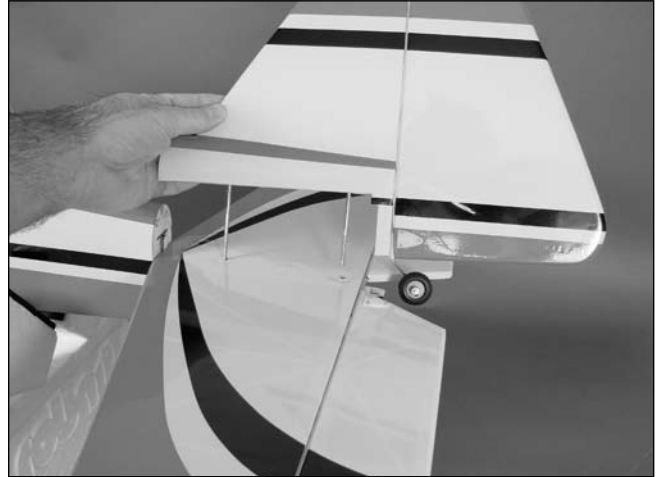

Step 4

Use two 6-32 lock nuts and two #6 washers to attach the tail to the fuselage. Do not over-tighten the nuts and damage the fuselage.

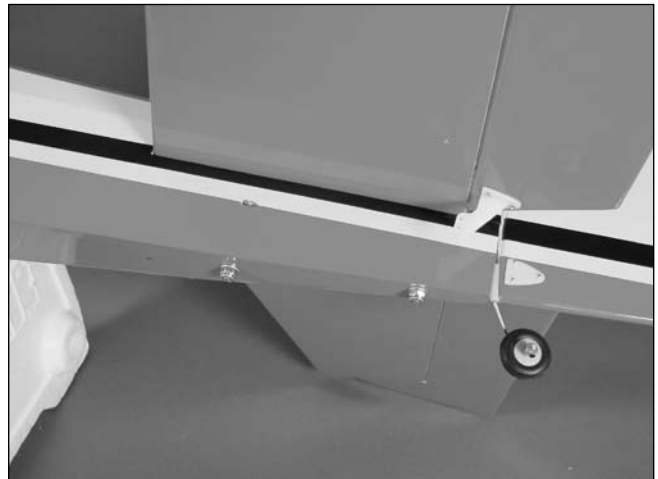

Section 3: Rudder and Elevator Installation

□ Step 5

Thread one of the servo mounting screws into each of the pre-drilled holes for the rudder and elevator servos as shown. This will cut the threads into the wood in preparation for the following step.



Note: If you are installing a glow engine, it is suggested to prepare the holes for the throttle servo at this time as well.

□ Step 6

After cutting the threads into the wood, apply a few drops of thin CA to each of the pre-drilled holes to harden the surrounding wood. This will provide a better surface for the screws and prevent vibration from loosening the screws in flight.



□□ Step 7

Prepare the rudder servo by installing the grommets and brass eyelets provided with the servo. Plug the rudder servo into the receiver and use the radio system to center the servo. Install a 180-degree servo horn onto the rudder servo as shown.

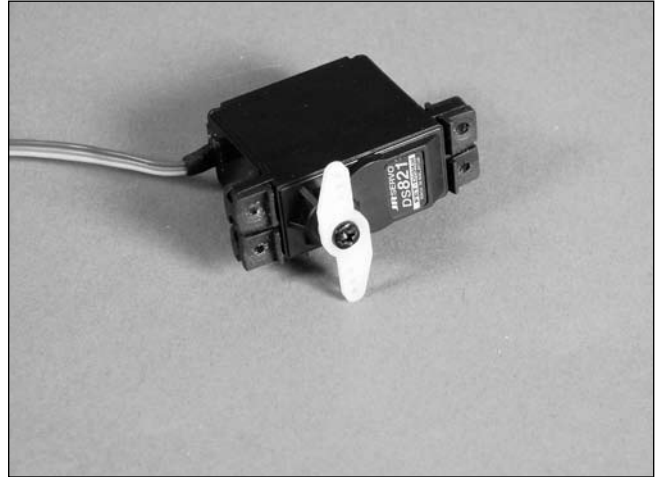

Note: The rudder and elevator servos are mirror images of each other. Use the following image to differentiate which servos are for rudder and elevator when performing the next steps.

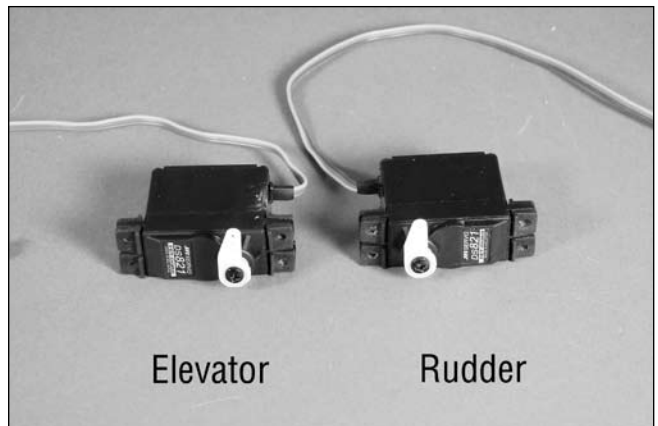

Section 3: Rudder and Elevator Installation

□□ Step 8

Use side cutters to remove one of the arms from the servo horn.

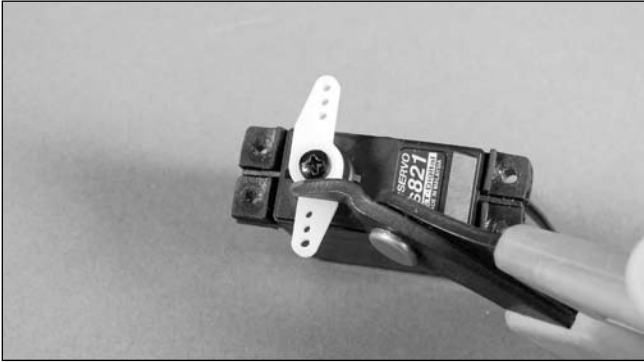

□□ Step 9

Use a 5/64-inch (2mm) drill bit to enlarge the outer hole of the servo arm.

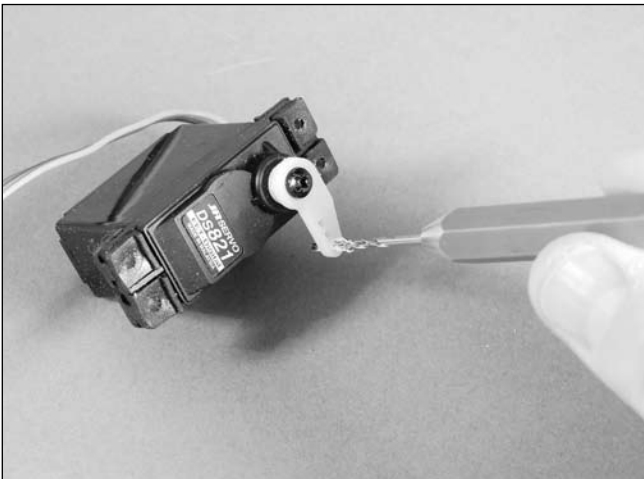

□ Step 10

Repeat Steps 7 through 9 to prepare the elevator servo. Note the direction of the servo arm in relationship to the rudder servo. The rudder and elevator servos are mirror images of each other.

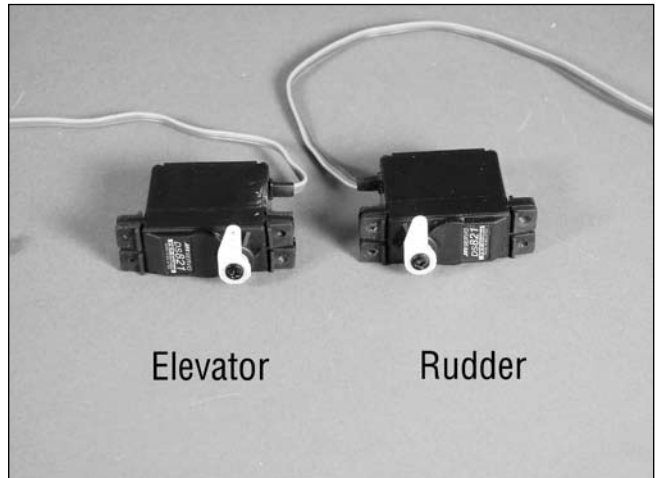

□ Step 11

Install the rudder and elevator servos using the hardware provided with the servos.



Section 3: Rudder and Elevator Installation

□ Step 12

Use low-tack tape to secure the elevators and rudder in the neutral position at this time.



□ Step 13

Slide a clevis retainer onto each one of the nylon clevises. Thread a clevis 14 turns onto each of the 27 1/2-inch (698mm) threaded pushrods.

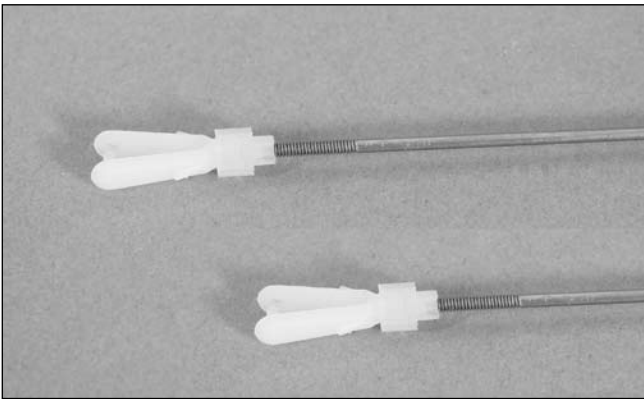

□ Step 14

Slide the pushrod into the hole on the right side of the fuselage.



□ Step 15

Attach the clevis to the center hole of the control horn.

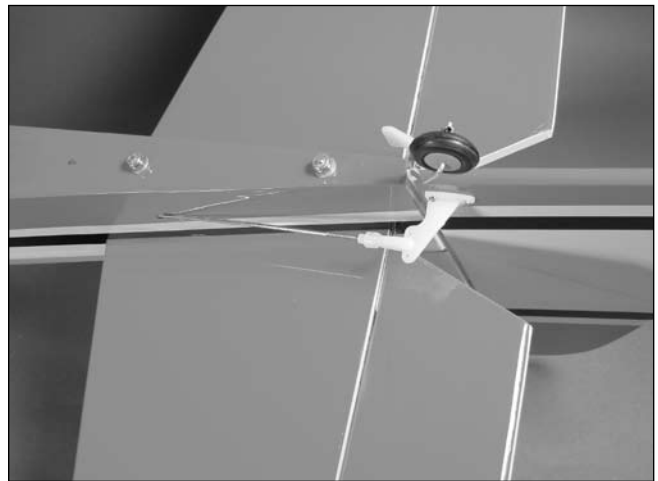

Section 3: Rudder and Elevator Installation

□□ Step 16

Center the rudder servo using the radio system. Use a felt-tipped pen to mark the pushrod where it crosses the outside servo arm hole.



□□ Step 17

Use pliers to make a 90-degree bend at the mark made in the previous step.



□□ Step 18

Secure the pushrod wire to the servo horn using a pushrod connector. The connector will slide onto the wire, then snap onto the wire under the servo arm.



□□ Step 19

Use side cutters to trim the pushrod wire so only 1/16-inch (1.5mm) extends beyond the connector.

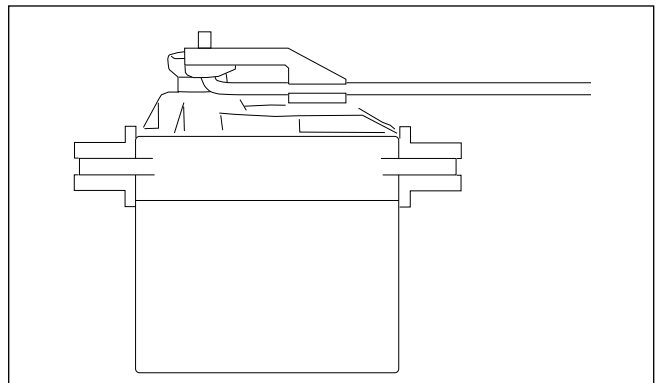

Hint: Use a flat file to remove any sharp edges at the end of the wire.

Section 3: Rudder and Elevator Installation

□ Step 20

Slide the pushrod into the hole on the left side of the fuselage.



□ Step 21

Attach the clevis to the center hole of the control horn.

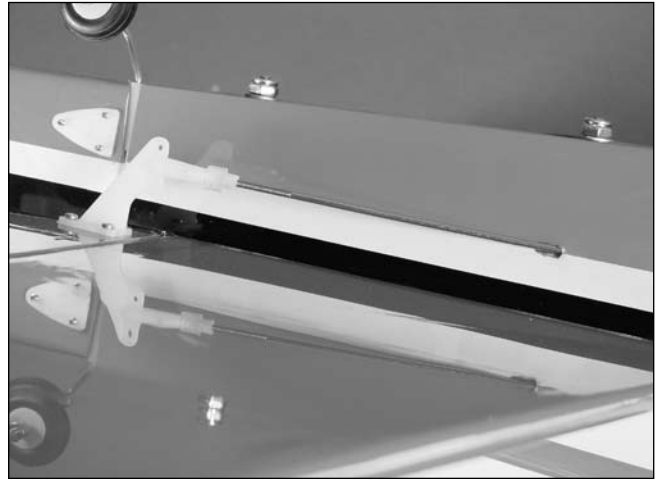

□ Step 22

Repeat Steps 17 through 20 to install the elevator linkage as shown in the photo.

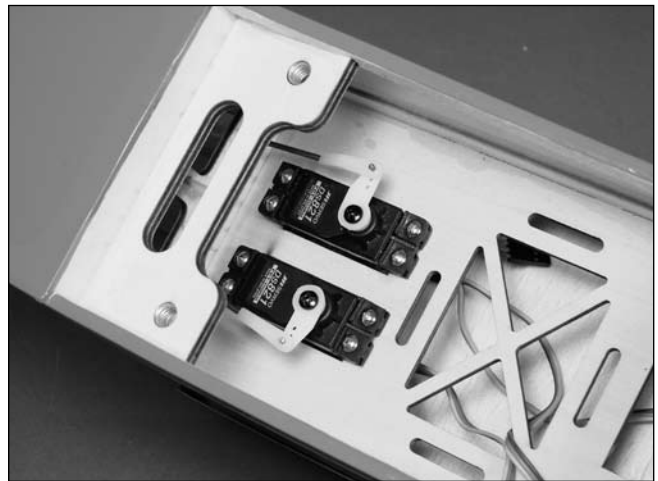

Section 4: Glow Engine and Cowling Installation

Required Parts

- Fuselage assembly
- Fuel tank
- 19³/₈-inch throttle pushrod
- Cowling
- #4 washer (4)
- Spinner assembly
- #8 washer (8)
- Throttle servo
- Hook and loop strap
- Standard servo arm
- 8-32 nylon lock nuts (4)
- 8-32 x 1 machine screw (4)
- 8-32 x 1¹/₄-inch machine screw (4)
- 4-40 x 3/8-inch socket head screw (4)
- Pushrod connector w/setscrew and snap keeper

Required Tools and Adhesives

- Screwdriver: #1 Phillips
- Pin drill
- Drill bit: 5/64-inch (2.5mm), 11/64-inch (4.5mm)
- Threadlock
- Hex wrench: 3/32-inch
- Propeller
- Rotary tool w/sanding drum
- Propeller reamer

□ Step 1

Attach the engine mount rails to the firewall using four 8-32 x 1-inch machine screws and four #8 washers.



Note: Use threadlock on the screws to prevent them from vibrating loose in flight.

□ Step 2

Position the engine on the engine mounting rails so the drive washer is 5³/₄-inch (146mm) forward of the firewall as shown.

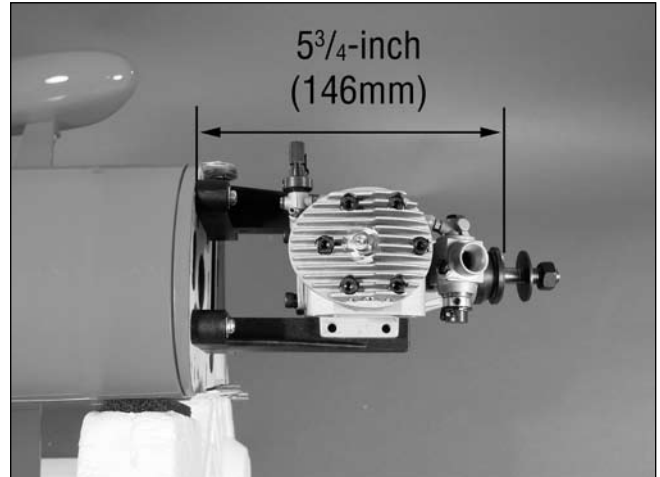

□ Step 3

Use a pencil to mark the locations for the four engine mounting screws onto the engine mounting rails.



Section 4: Glow Engine and Cowling Installation

□ Step 4

Drill the locations for the engine mounting screws using a drill and 11/64-inch (4.5mm) drill bit.

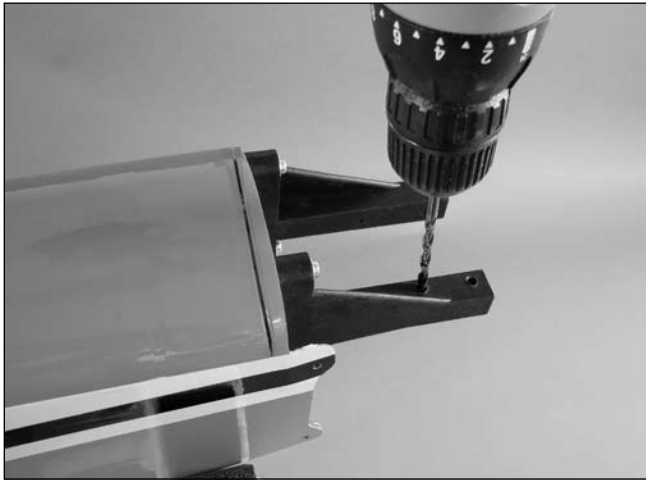

Hint: Using a drill press will guarantee the holes are parallel to the mounting rails.

□ Step 5

Secure the engine to the engine mounting rails using 8-32 x 1 1/4-inch machine screws, four #8 washers and four 8-32 lock nuts.

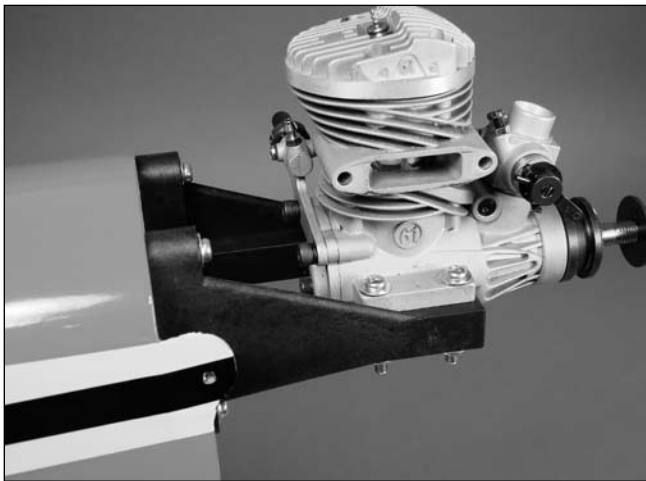

□ Step 6

Use a 5/64-inch (2mm) drill bit to enlarge the outer hole in the carburetor arm.



□ Step 7

Slide the brass connector into the hole. The connector will face outward as shown.

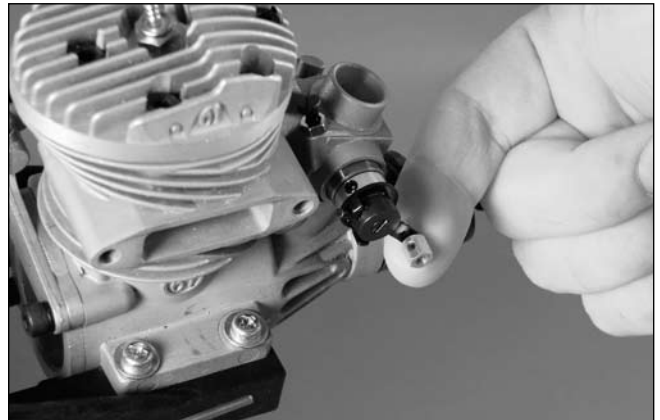

□ Step 8

Secure the connector using the nylon connector backplate.



Section 4: Glow Engine and Cowling Installation

Special Steps for 4-Stroke Installation

The following steps are required to provide clearance between the carburetor arm and engine mounting rail.

□ Step 1

Loosen the setscrew securing the carburetor arm to the carburetor. Trace the arc of the arm onto the engine mounting rail using a pencil.

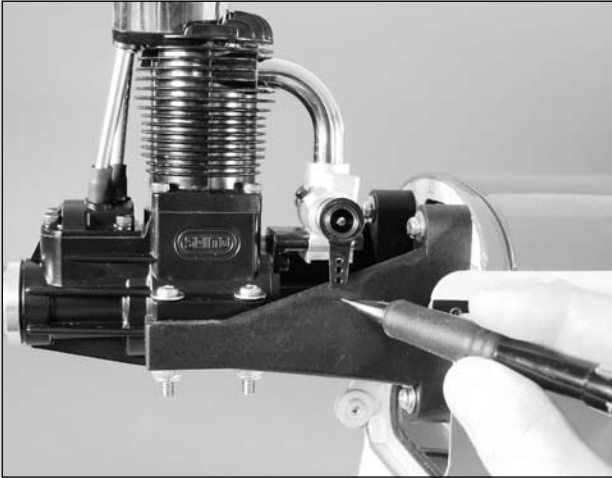

□ Step 2

Remove the engine mounting rail from the fuselage and engine. Use a rotary tool and sanding drum to remove the material from the engine mounting rail to provide clearance for the carburetor arm.



□ Step 3

Remove the carburetor arm from the carburetor. Use a 5/64-inch (2mm) drill bit to enlarge the outer hole in the carburetor arm.

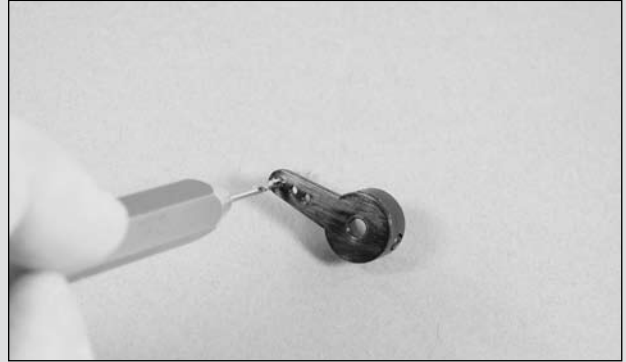

□ Step 4

Slide the brass connector into the hole. The connector will face outward as shown.

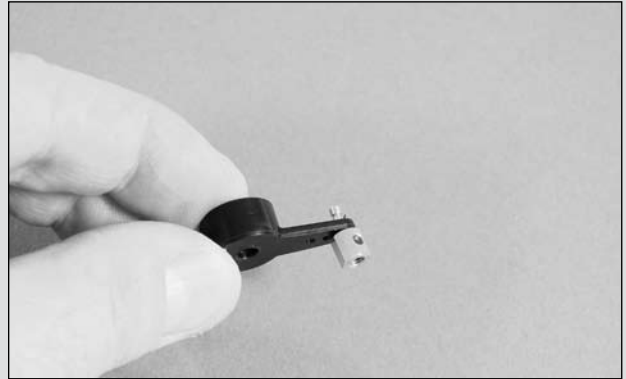

□ Step 5

Secure the connector using the nylon connector backplate.



Section 4: Glow Engine and Cowling Installation

□ Step 9

Slide the throttle pushrod into the pushrod tube on the same side of the fuselage as the carburetor arm.

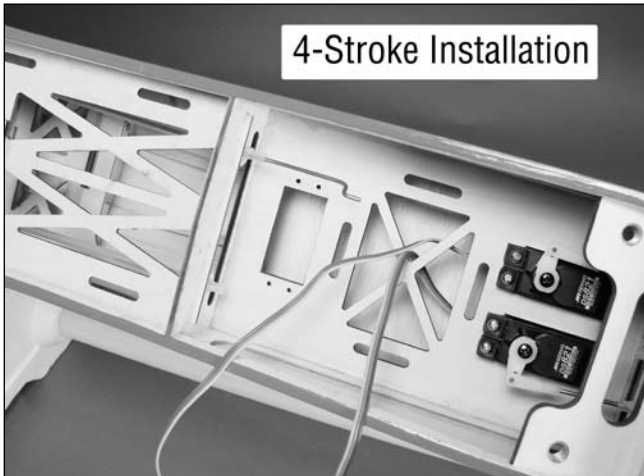

□ Step 10a

Slide the pushrod through the connector on the carburetor arm as shown. Do not tighten the screw at this time.

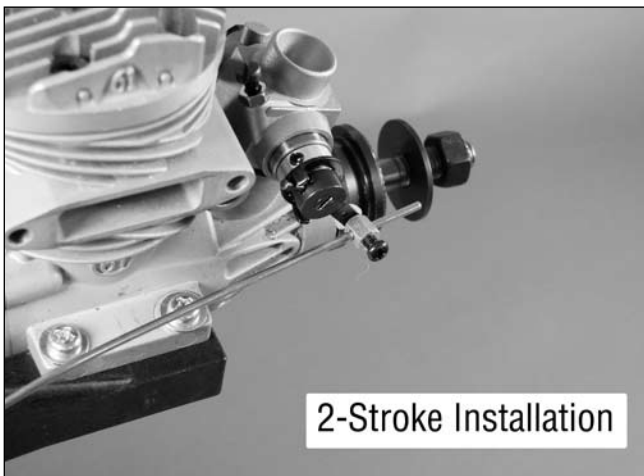

□ Step 10b

Slide the connector (and carburetor arm) onto the throttle pushrod. Re-attach the carburetor arm to the engine, making sure it is positioned to operate the carburetor properly.

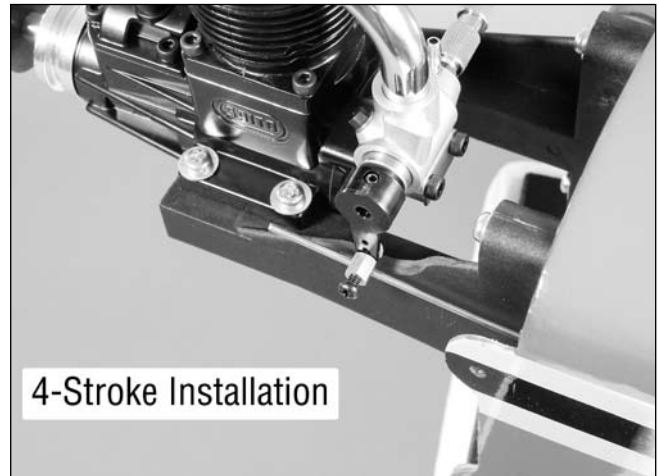

Note: The final setup of the throttle will take place later in the manual.

□ Step 11

Pass a hook and loop strap through the slots in the fuselage as shown.

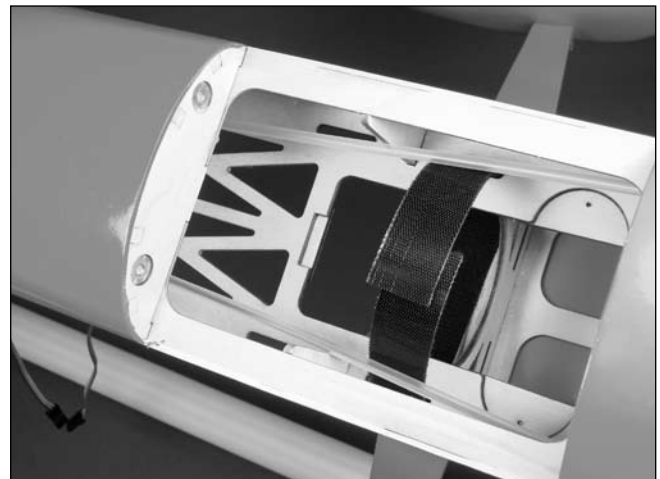

Section 4: Glow Engine and Cowling Installation

□ Step 12

Look carefully at the fuel tank to determine which tubes are for the carburetor and vent. Also check the direction of the vent line inside the fuel tank. The vent will face the top of the fuselage when the fuel tank is installed. Use the drawings below as a reference for the fuel lines.

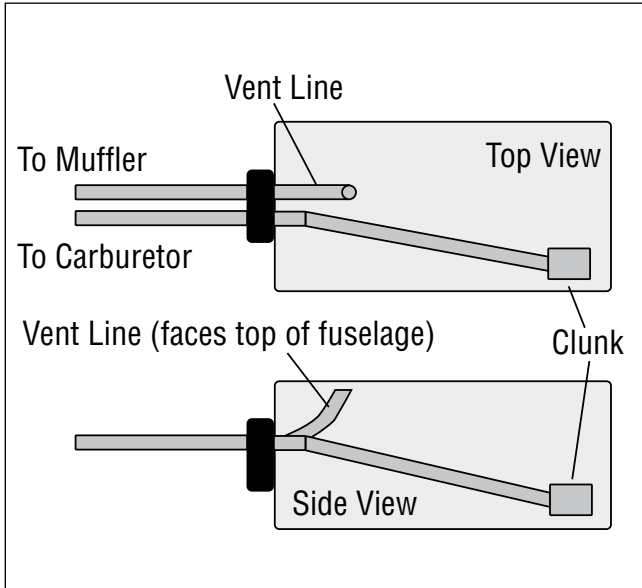

□ Step 13

Insert the fuel tank into the fuselage, noting that the vent line faces toward the top of the fuselage.



□ Step 14

Use a 5/64-inch (2mm) drill bit and pin drill to enlarge the outer hole of a standard servo arm as shown.

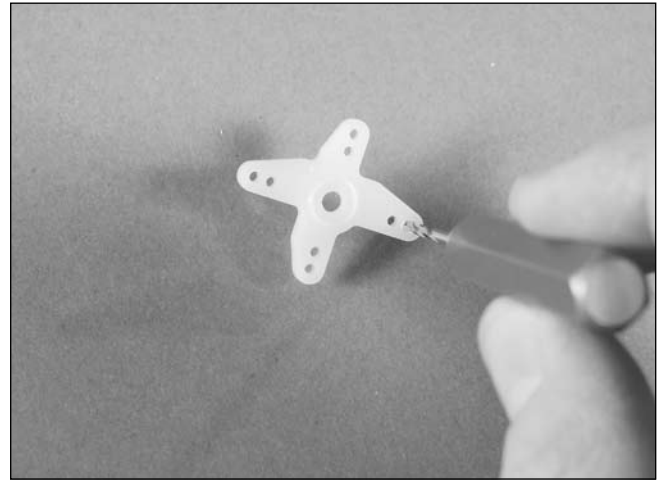

□ Step 15

Use side cutters to remove the excess arms from the servo horn so they don't interfere with the operation of the throttle servo.

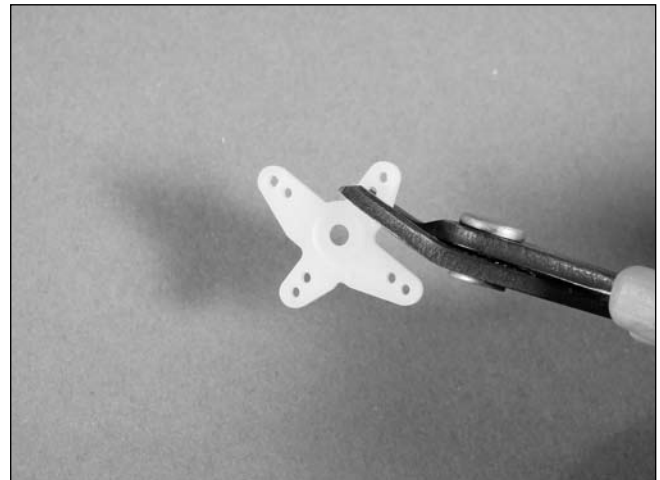

Section 4: Glow Engine and Cowling Installation

□ Step 16

Plug the throttle servo into the receiver. Center the throttle stick and trim at the transmitter. With the throttle servo centered, install the servo horn as shown in the photo.



□ Step 17

Install the throttle servo in the fuselage using the hardware provided with the servo. The output of the servo will be oriented toward the pushrod wire.



□ Step 18

With the throttle stick and trim centered, open the carburetor to the mid-throttle position. Tighten the screw that secures the pushrod wire at the carburetor.

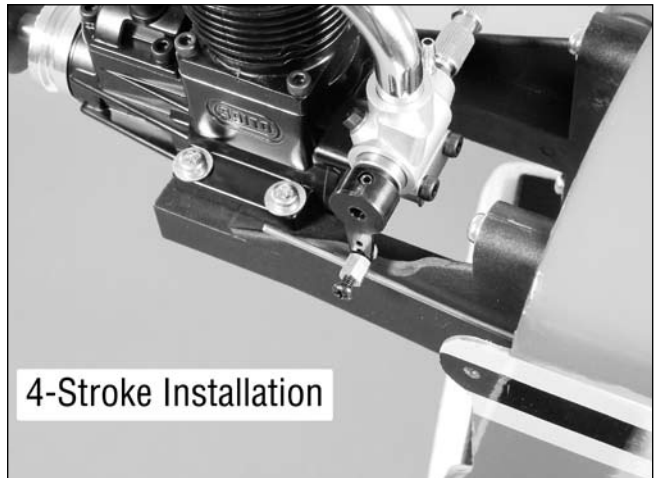

□ Step 19

Use the travel volumes in the transmitter to make sure you are achieving full throttle and not over throwing and binding the servo.

Section 4: Glow Engine and Cowling Installation

□ Step 20

Use side cutters to remove the excess pushrod wire that could interfere with the operation of your engine.



Note: Use threadlock on the screw to prevent it from vibrating loose in flight.

□ Step 21

Use cardstock to make a template that fits over your particular engine. The template should allow for clearance of the engine head, muffler, carburetor and any other items that might protrude outside the cowl.

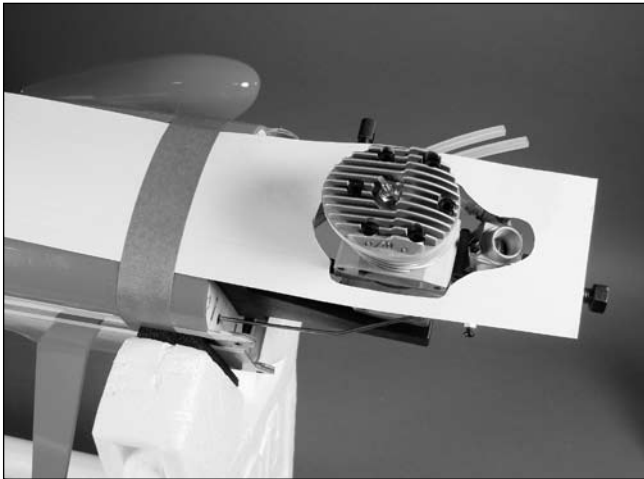

□ Step 22

Slide the cowl onto the fuselage. Use four 4-40 x 3/8-inch socket head screws and four #4 washers to secure the cowl to the fuselage. Use a felt-tipped pen to trace the outline from the template onto the cowl.



□ Step 23

Use hobby scissors and a rotary tool with a sanding drum to trim the cowl. It is better to remove as little material from the cowl as possible, then fit the cowl over the engine to finalize the trimming process.

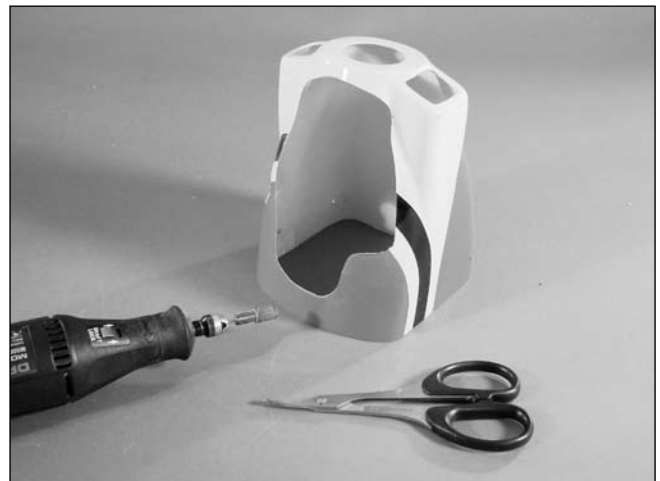

Section 4: Glow Engine and Cowling Installation

□ Step 24

Install the engine back onto the engine mount. Slide the cowling over the engine, trimming the cowl as necessary to fit over the engine and provide clearance for items such as the needle valve and muffler. The cowl can be secured using the four 4-40 x 3/8-inch socket head screws and four #4 washers at this time.



□ Step 25

Slide the spinner backplate onto the propeller shaft.

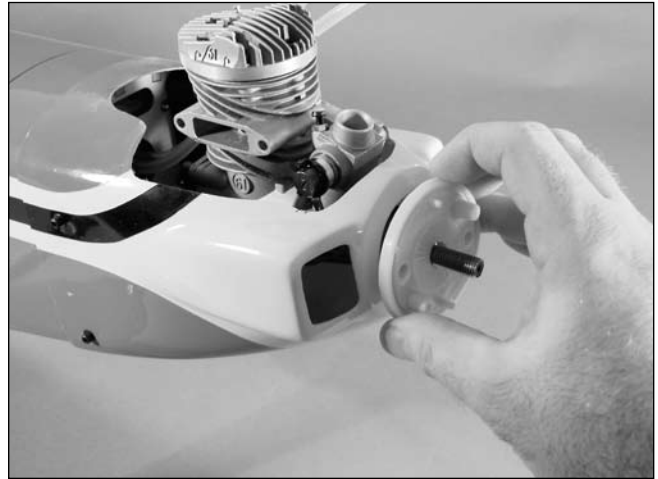

□ Step 26

Slide the propeller into position, aligning it with the pins on the spinner backplate.

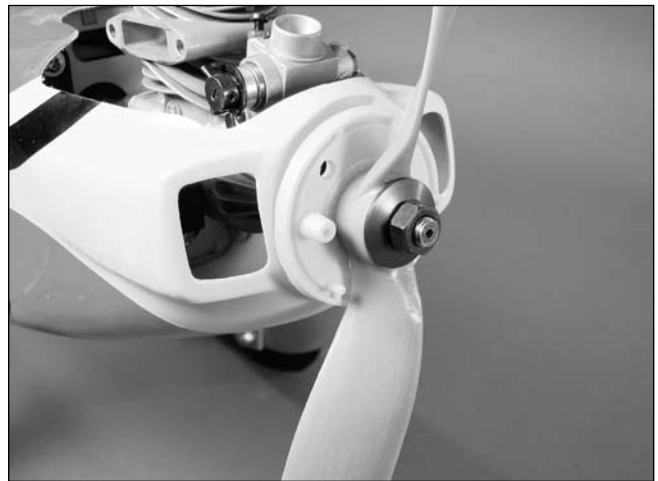

Section 4: Glow Engine and Cowling Installation

□ Step 27

Use a #1 Phillips screwdriver and the screws supplied with the spinner to secure the spinner cone to the backplate.



Note: The propeller must not contact the spinner cone. Adjust the position of the propeller on the backplate, or use a rotary tool and sanding drum to remove material from the spinner cone so the two do not contact each other.

□ Step 28

Attach the muffler as instructed in the manual for your particular engine.



□ Step 29

Connect the lines from the fuel tank to the engine. Make sure the vent line is attached to the muffler and the line from the clunk to the carburetor. Cut down the length of the line as necessary so it does not interfere with the operation of your engine.



Section 4: Glow Engine and Cowling Installation



Note: We install a Dubro inline fuel filter (DUB340) between the fuel tank and carburetor.

Section 5: Electric Motor and Cowling Installation

Required Parts

- Fuselage assembly
- Plywood battery tray
- Motor w/hardware
- Motor battery
- #4 washer (4)
- Spinner assembly
- Cowling
- Hook and loop strap (long) (2)
- 8-32 x 3-inch machine screw (4)
- 60-amp electronic speed control
- #4 x 3/8-inch sheet metal screw (2)
- 4-40 x 3/8-inch socket head screw (4)
- 2⁷/₁₆-inch (62mm) aluminum standoff (4)

Required Tools and Adhesives

- Hobby knife
- Drill
- Drill bit: 5/32-inch (4mm)
- Threadlock
- Hex wrench: 3/32-inch
- Propeller
- Phillips screwdriver: #1
- Propeller reamer
- Rotary tool w/sanding drum

□ Step 1

Use a hobby knife to remove the plywood from the openings in the firewall. This will allow cooling air to pass through the fuselage to keep the electronics cooler in flight.



Section 5: Electric Motor and Cowling Installation

□ Step 2

Route the two longer hook and loop straps through the slots inside the fuselage.

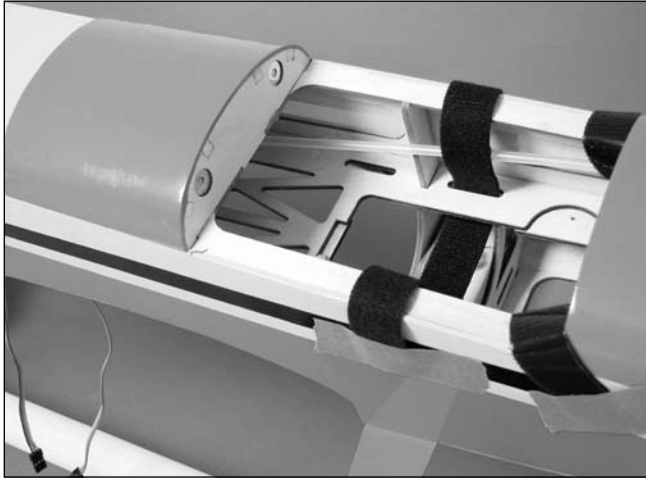

Hint: Low-tack masking tape can be used to keep the straps on the outside of the fuselage to ease the installation of the battery tray.

□ Step 3

Secure the ESC to the bottom of the battery tray using hook and loop tape.

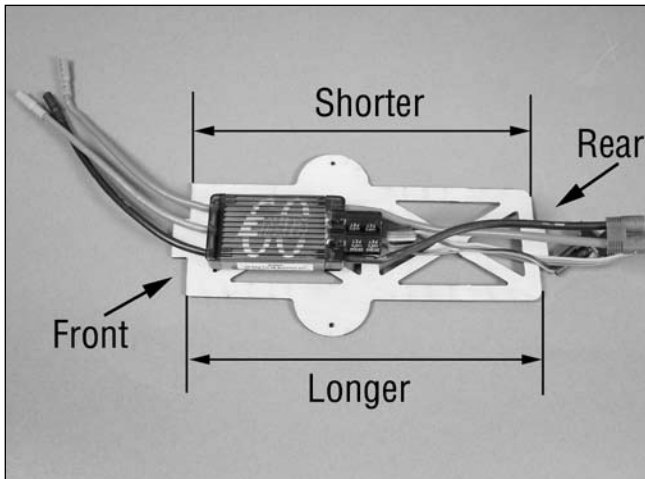

Note: The front edge of the battery tray is angled to match the thrust angle of the firewall. Use the photo to orient the battery tray correctly before attaching the ESC.

□ Step 4

Slide the battery tray into the fuselage with the ESC facing toward the bottom of the fuselage. Secure the battery tray in the fuselage using two #4 x 3/8-inch sheet metal screws.

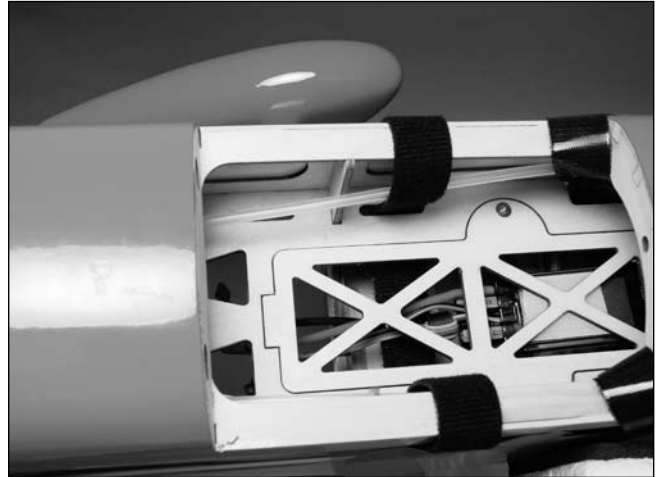

□ Step 5

Use a drill and 5/32-inch (4mm) drill bit to enlarge the mounting holes in the X-mount.

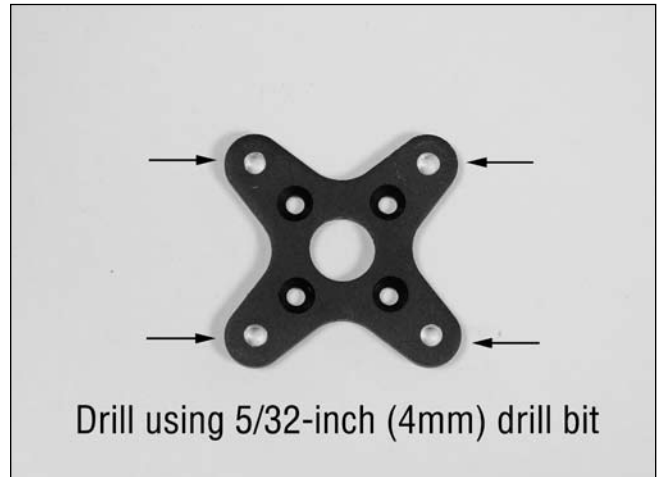

Section 5: Electric Motor and Cowling Installation

□ Step 6

Attach the X-mount to the motor using the screws provided with the motor.

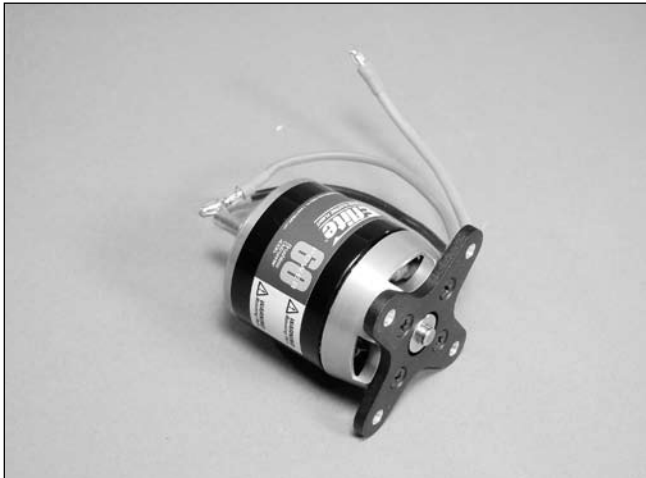

Note: Use threadlock on the screws to prevent them from vibrating loose in flight.

□ Step 7

Attach the motor to the firewall using four $2\frac{7}{16}$ -inch (62mm) aluminum standoffs and four 8-32 x 3-inch machine screws. Connect the motor to the ESC at this time as well.

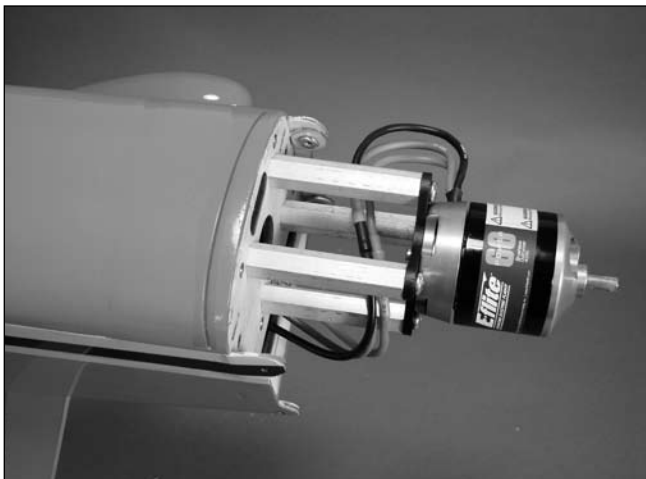

Note: Use threadlock on the screws to prevent them from vibrating loose in flight.

□ Step 8

Secure the motor battery inside the fuselage using the hook and loop straps.



Note: If the battery slides on the tray, it may change the Center of Gravity. To prevent the battery from moving, apply hook and loop tape to the battery and the battery tray. This will keep the battery from sliding on the tray.



Section 5: Electric Motor and Cowling Installation

□ Step 9

Slide the cowling onto the fuselage. Use four 4-40 x 3/8-inch socket head screws and four #4 washers to secure the cowling to the fuselage.



Note: Use threadlock on the screws to prevent them from vibrating loose in flight.

□ Step 10

Slide the spinner backplate onto the propeller shaft or adapter for your particular motor.



□ Step 11

Slide the propeller into position, aligning it with the pins on the spinner back plate.



□ Step 12

Use a #1 Phillips screwdriver and the screws supplied with the spinner to secure the spinner cone to the backplate.



Note: The propeller must not contact the spinner cone. Adjust the position of the propeller on the backplate, or use a rotary tool and sanding drum to remove material from the spinner cone so the two do not contact each other.

Section 6: Receiver Installation

Required Parts

- Fuselage assembly
- Receiver
- Y-harness or two 3-inch (76mm) extensions
- Hook and loop strap (short)
- Switch
- Receiver battery

Required Tools and Adhesives

- Foam rubber
- Masking tape

□ Step 1

Install the switch harness on the side of the fuselage. The covering will have to be removed from the fuselage using a hobby knife to expose the opening.

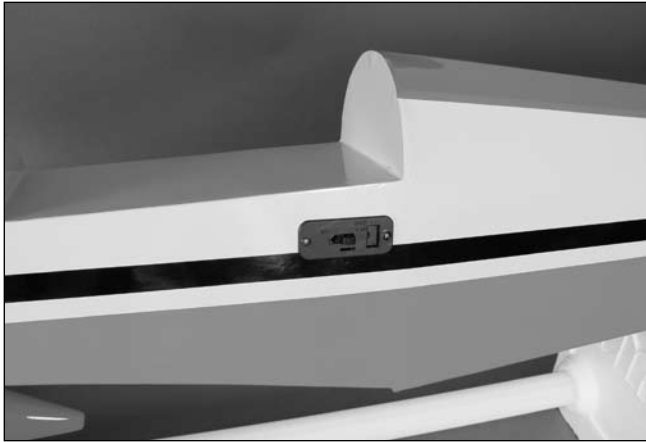

Note: A pre-cut opening for a smaller switch harness is located near the front of the cockpit of your model.

□ Step 2

Wrap the receiver in foam to protect it from vibration. Make the connections for any servos, extensions or switches to the receiver.



□ Step 3

Secure the receiver as shown using a hook and loop strap. When using a remote receiver, attach the receiver as described in the instructions provided with your radio system, placing it as far away from the main receiver and as high in the fuselage as possible.

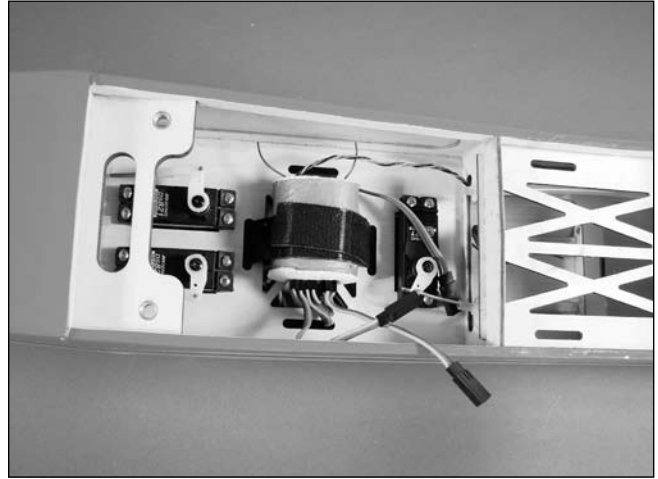

Note: An antenna tube has been installed in the fuselage between the servos to route the receiver antenna to the rear of the fuselage.

□ Step 4

Wrap the receiver battery in foam to protect it from vibration. Secure the receiver battery as shown using a hook and loop strap. The receiver battery can be moved rearward in the fuselage to correctly balance your aircraft if necessary.

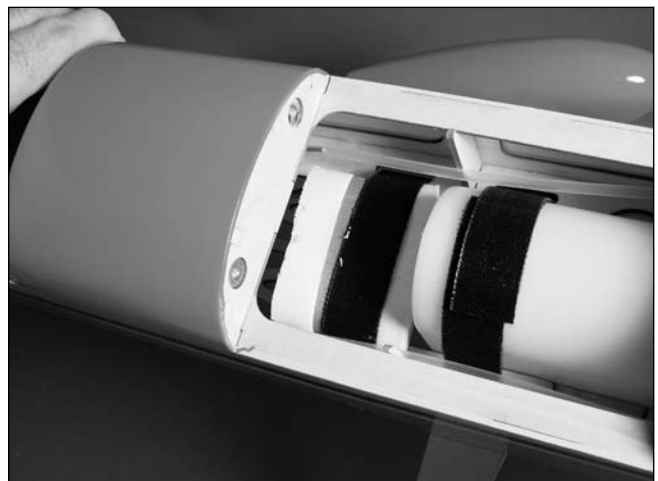

Section 7: Canopy and Wing Installation

Required Parts

- Fuselage assembly
- Canopy
- Wing panel (right and left)
- Wing dowel (2)
- Wing tube
- Plywood wing bolt plate
- 1/4-20 x 2-inch nylon wing bolt (2)
- 1³/₁₆-inch x 3/16-inch (81mm x 4.75mm) aluminum anti-rotation pin

Required Tools and Adhesives

- Low-tack masking tape
- Ruler
- 30-minute epoxy
- Medium sandpaper
- Paper towel
- Rubbing alcohol

□ Step 1

Position the canopy on the fuselage. Trace the outline of the canopy on the fuselage.



□ Step 2

Use medium sandpaper to scuff the fuselage and canopy where they contact each other. Use rubbing alcohol and a paper towel to remove any debris from the gluing area.



□ Step 3

Use canopy glue to secure the canopy to the fuselage. Low-tack tape is suggested to keep the canopy in position until the glue has fully cured.



Section 7: Canopy and Wing Installation

□ Step 4

Use 30-minute epoxy to glue the wooden dowel into the hole in the leading edge of the wing. Leave 1/2-inch (13mm) of the dowel protruding from the wing as shown. Glue dowels in both wing panels at this time.

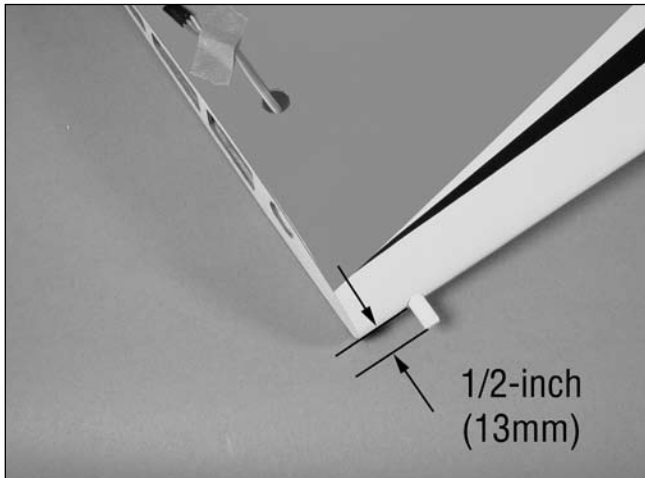

□ Step 5

Carefully slide the aluminum wing tube into the wing panel as shown. The tube will slide half way into the wing, as there is a stop inside the wing to prevent it from sliding in any further than necessary.

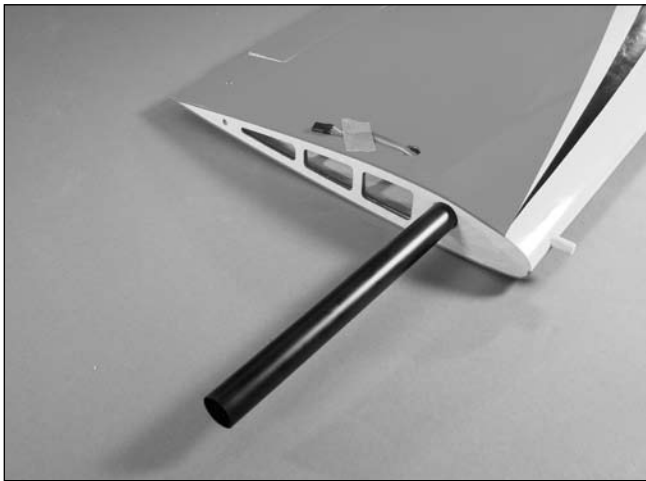

□ Step 6

Install the 1 3/16-inch x 3/16-inch (81mm x 4.75mm) aluminum anti-rotation pin in the hole near the trailing edge of the wing. Use medium CA to glue the pin in position so it will not fall out and get lost.

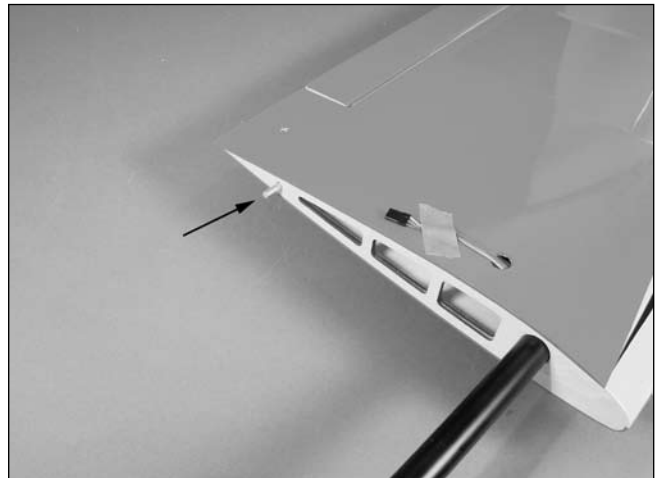

□ Step 7

Slide the remaining wing panel on the wing tube. Press the two wing panels tightly together.



Section 7: Canopy and Wing Installation

Step 8

Connect the extensions (or Y-harness) from the receiver to the aileron servos.

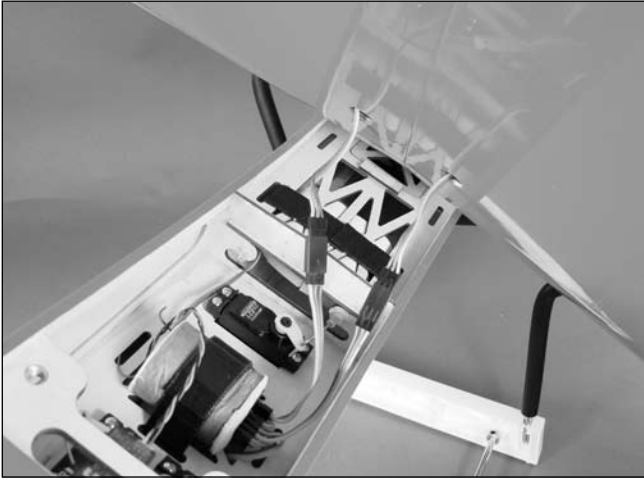

Step 9

Attach the wing to the fuselage using two 1/4-20 x 2-inch nylon wing bolts and the plywood wing bolt plate.

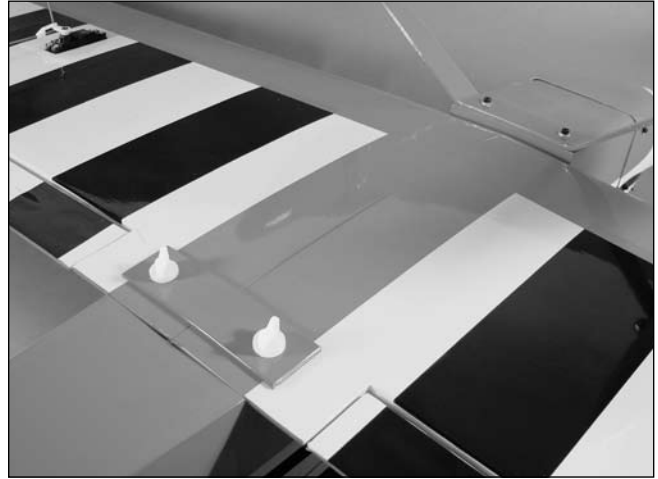

Section 8: Control Throws

The amount of control throw should be adjusted as closely as possible using mechanical means, rather than making large changes electronically at the radio. By moving the position of the clevis at the control horn toward the outermost hole, you will decrease the amount of control throw of the control surface. Moving it toward the control surface will increase the amount of throw. Moving the pushrod wire at the servo arm will have the opposite effect, moving it closer to center will decrease throw, and away from center will increase throw. Work with a combination of the two to achieve the closest or exact control throws listed.

Aileron Low Rate

14 degrees up/down

7/16-inch up/down

11mm up/down

Aileron High Rate

20 degrees up/down

5/8in up/down

16mm up/down

Elevator Low Rate

18 degrees up/down

3/4-inch up/down

19mm up/down

Elevator High Rate

25 degrees up/down

1 1/8-inch up/down

29mm up/down

Rudder Low Rate

22 degrees right/left

2 1/4-inch right/left

57mm right/left

Rudder High Rate

30 degrees right/left

3-inch right/left

76mm right/left

Note: All control throws are measured at the widest point of the control surface.

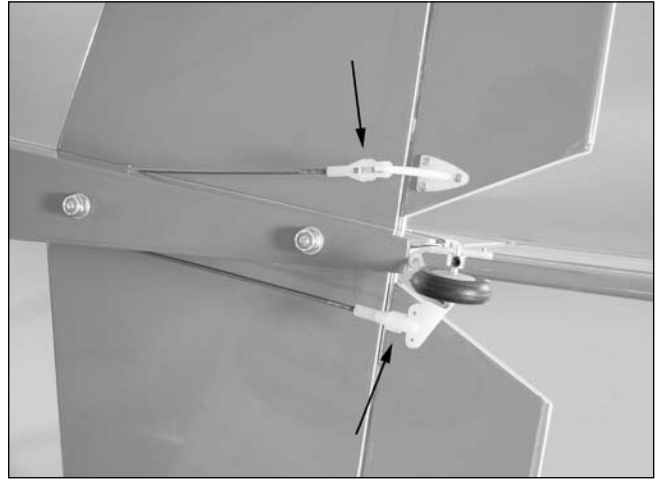

Once the control throws have been set, slide the clevis retainers over the clevis to prevent them from opening during flight.

Section 9: Recommended Center of Gravity (CG)

An important part of preparing the aircraft for flight is properly balancing the model. This is especially important when various engines are mounted.

Caution: Do not inadvertently skip this step!

□ Step 1

The recommended Center of Gravity (CG) location for the Pulse XT 60 is $3\frac{3}{8}$ inches (86mm) behind the leading edge of the wing against the fuselage. Mark the location of the Center of Gravity on the top of the wing.

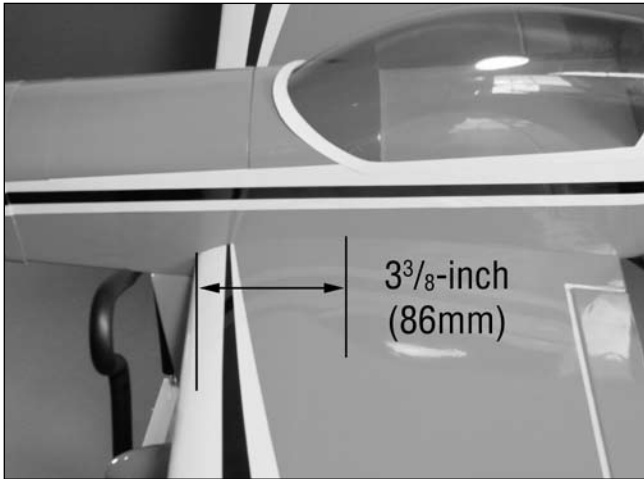

Note: The Center of Gravity can also be measured at the wing tips using the above measurements.

□ Step 2

When balancing a low-wing aircraft, it is best to balance it inverted as shown in the drawing below.

Place your aircraft on a balancing stand, or lift the model with your fingertips, at the marks made in the previous step. The aircraft should rest level or slightly nose down when balanced correctly. If necessary, move the battery pack or add weight to either the nose or the tail until the correct balance is achieved. Stick-on weights are available at your local hobby store and work well for this purpose.

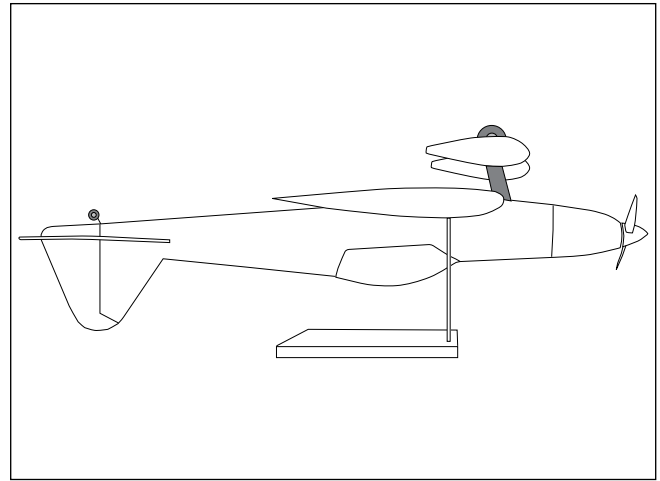

Note: The range for the Center of Gravity is $3-3\frac{3}{4}$ inches (76mm–95mm). You can change the Center of Gravity within this range based on your personal flight preference.

Section 10: Pre-Flight

Charge both the transmitter and receiver pack for your airplane. Use the recommended charger supplied with your particular radio system, following the instructions provided with the radio. In most cases, the radio should be charged the night before going out flying.

Check the radio installation and make sure all the control surfaces are moving correctly (i.e. the correct direction and with the recommended throws). Test run the engine and make sure it transitions smoothly from idle to full throttle and back. Also ensure the engine is tuned according to the manufacturer's instructions, and it will run consistently and constantly at full throttle when adjusted.

Check all the control horns, servo horns and clevises to make sure they are secure and in good condition. Replace any items that would be considered questionable. Failure of any of these components in flight would mean the loss of your aircraft.

Section 11: Adjusting the Engine

Step 1

Completely read the instructions included with your engine and follow the recommended break in procedure.

Step 2

At the field, adjust the engine to a slightly rich setting at full throttle and adjust the idle and low-speed needle so that a consistent idle is achieved.

Step 3

Before you fly, be sure that your engine idles reliably, transitions and runs at all throttle settings. Only when this is achieved should any plane be considered ready for flight.

Section 12: Range Testing Your Radio

Range check your radio system before each flying session. This is accomplished by turning on your transmitter with the antenna collapsed. Turn on the radio in your airplane. With your airplane on the ground, you should be able to walk 30 paces away from your airplane and still have complete control of all functions. If not, don't attempt to fly! Have your radio equipment checked out by the manufacturer.

2008 Official AMA National Model Aircraft Safety Code

GENERAL

1. A model aircraft shall be defined as a non-human-carrying device capable of sustained flight in the atmosphere. It shall not exceed limitations established in this code and is intended to be used exclusively for recreational or competition activity.
2. The maximum takeoff weight of a model aircraft, including fuel, is 55 pounds, except for those flown under the AMA Experimental Aircraft Rules.
3. I will abide by this Safety Code and all rules established for the flying site I use. I will not willfully fly my model aircraft in a reckless and/or dangerous manner.
4. I will not fly my model aircraft in sanctioned events, air shows, or model demonstrations until it has been proven airworthy.
5. I will not fly my model aircraft higher than approximately 400 feet above ground level, when within three (3) miles of an airport without notifying the airport operator. I will yield the right-of-way and avoid flying in the proximity of full-scale aircraft, utilizing a spotter when appropriate.
6. I will not fly my model aircraft unless it is identified with my name and address, or AMA number, inside or affixed to the outside of the model aircraft. This does not apply to model aircraft flown indoors.
7. I will not operate model aircraft with metal-blade propellers or with gaseous boosts (other than air), nor will I operate model aircraft with fuels containing tetranitromethane or hydrazine.
8. I will not operate model aircraft carrying pyrotechnic devices which explode burn, or propel a projectile of any kind. Exceptions include Free Flight fuses or devices that burn producing smoke and are securely attached to the model aircraft during flight. Rocket motors up to a G-series size may be used, provided they remain firmly attached to the model aircraft during flight. Model rockets may be flown in accordance with the National Model Rocketry Safety Code; however, they may not be launched from model aircraft. Officially designated AMA Air Show Teams (AST) are authorized to use devices and practices as defined within the Air Show Advisory Committee Document.
9. I will not operate my model aircraft while under the influence of alcohol or within eight (8) hours of having consumed alcohol.
10. I will not operate my model aircraft while using any drug which could adversely affect my ability to safely control my model aircraft.
11. Children under six (6) years old are only allowed on a flightline or in a flight area as a pilot or while under flight instruction.
12. When and where required by rule, helmets must be properly worn and fastened. They must be OSHA, DOT, ANSI, SNELL or NOCSAE approved or comply with comparable standards.

2008 Official AMA National Model Aircraft Safety Code

Radio Control

1. All model flying shall be conducted in a manner to avoid over flight of unprotected people.
2. I will have completed a successful radio equipment ground-range check before the first flight of a new or repaired model aircraft.
3. I will not fly my model aircraft in the presence of spectators until I become a proficient flier, unless I am assisted by an experienced pilot.
4. At all flying sites a line must be established, in front of which all flying takes place. Only personnel associated with flying the model aircraft are allowed at or in front of the line. In the case of airshows demonstrations straight line must be established. An area away from the line must be maintained for spectators. Intentional flying behind the line is prohibited.
5. I will operate my model aircraft using only radio-control frequencies currently allowed by the Federal Communications Commission (FCC). Only individuals properly licensed by the FCC are authorized to operate equipment on Amateur Band frequencies.
6. I will not knowingly operate my model aircraft within three (3) miles of any preexisting flying site without a frequency-management agreement. A frequency-management agreement may be an allocation of frequencies for each site, a day-use agreement between sites, or testing which determines that no interference exists. A frequency-management agreement may exist between two or more AMA chartered clubs, AMA clubs and individual AMA members, or individual AMA members. Frequency-management agreements, including an interference test report if the agreement indicates no interference exists, will be signed by all parties and copies provided to AMA Headquarters.
7. With the exception of events flown under official AMA rules, no powered model may be flown outdoors closer than 25 feet to any individual, except for the pilot and located at the flight line.
8. Under no circumstances may a pilot or other person touch a model aircraft in flight while it is still under power, except to divert it from striking an individual.
9. Radio-controlled night flying is limited to low-performance model aircraft (less than 100 mph). The model aircraft must be equipped with a lighting system which clearly defines the aircraft's attitude and direction at all times.
10. The operator of a radio-controlled model aircraft shall control it during the entire flight, maintaining visual contact without enhancement other than by corrective lenses that are prescribed for the pilot. No model aircraft shall be equipped with devices which allow it to be flown to a selected location which is beyond the visual range of the pilot.



Fly First Class™



© 2008 Horizon Hobby, Inc.
4105 Fieldstone Road
Champaign, Illinois 61822
(877) 504-0233
horizonhobby.com