

# SPITFIRE

## INSTRUCTION MANUAL

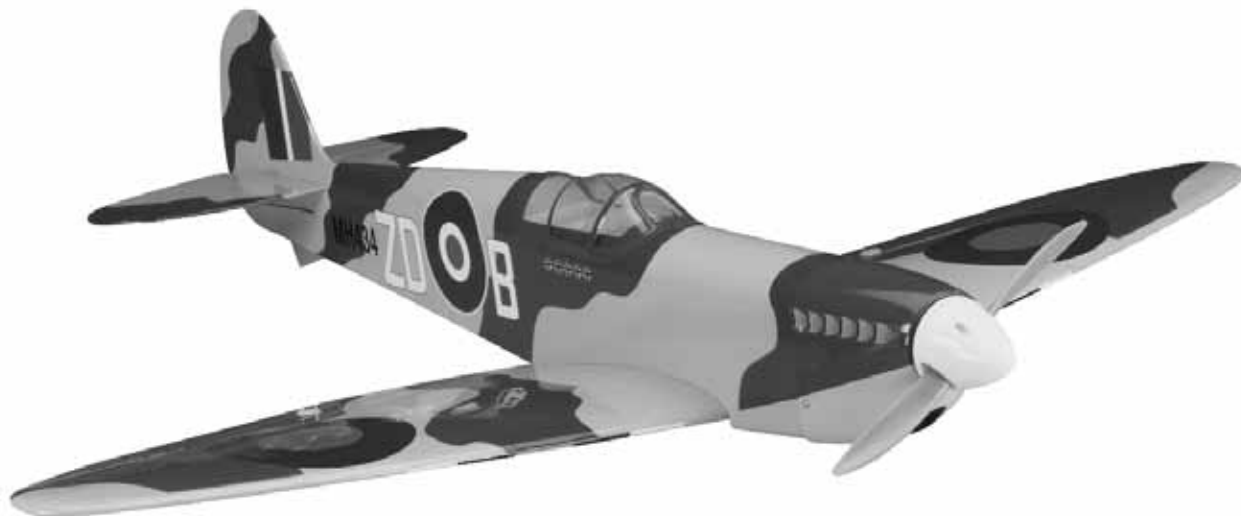

**Wingspan:** 39 in [990mm]  
**Wing Area:** 272 in<sup>2</sup> [17.5dm<sup>2</sup>]  
**Weight:** 40 – 48 oz [1130 – 1360g]  
**Wing Loading:** 21 – 25 oz/ft<sup>2</sup> [65 – 78g/dm<sup>2</sup>]  
**Length:** 35.5 in [895mm]  
**Radio:** 4-channel minimum w/4 to 5 micro servos and standard size receiver  
**Engine:** .25 cu in [4cc] two-stroke, 35-30-1450kV RimFire™ out-runner motor



### WARRANTY

**Great Planes® Model Manufacturing Co.** guarantees this kit to be free from defects in both material and workmanship at the date of purchase. This warranty does not cover any component parts damaged by use or modification. **In no case shall Great Planes' liability exceed the original cost of the purchased kit.** Further, Great Planes reserves the right to change or modify this warranty without notice.

In that Great Planes has no control over the final assembly or material used for final assembly, no liability shall be assumed nor accepted for any damage resulting from the use by the user of the final user-assembled product. By the act of using the user-assembled product, the user accepts all resulting liability.

**If the buyer is not prepared to accept the liability associated with the use of this product, the buyer is advised to return this kit immediately in new and unused condition to the place of purchase.**

To make a warranty claim send the defective part or item to Hobby Services at the address below:

Hobby Services  
3002 N. Apollo Dr. Suite 1  
Champaign IL 61822 USA

Include a letter stating your name, return shipping address, as much contact information as possible (daytime telephone number, fax number, e-mail address), a detailed description of the problem and a photocopy of the purchase receipt. Upon receipt of the package the problem will be evaluated as quickly as possible.

**READ THROUGH THIS MANUAL BEFORE STARTING CONSTRUCTION. IT CONTAINS IMPORTANT INSTRUCTIONS AND WARNINGS CONCERNING THE ASSEMBLY AND USE OF THIS MODEL.**

  
Champaign, Illinois  
(217) 398-8970, Ext 5  
airsupport@greatplanes.com

## TABLE OF CONTENTS

INTRODUCTION .....	2
AMA .....	2
SAFETY PRECAUTIONS.....	3
DECISIONS YOU MUST MAKE .....	3
Radio Equipment.....	3
Power System Recommendations .....	3
Batteries & Charger.....	4
Propeller .....	4
ADDITIONAL ITEMS REQUIRED.....	4
Required Hardware & Accessories .....	4
Adhesives & Building Supplies.....	4
Optional Supplies & Tools .....	4
Building Stand .....	5
IMPORTANT BUILDING NOTES .....	5
ORDERING REPLACEMENT PARTS .....	5
COMMON ABBREVIATIONS.....	6
METRIC CONVERSIONS .....	6
KIT INSPECTION .....	7
KIT CONTENTS .....	7
PREPARATIONS .....	8
BUILD THE WING .....	8
Install the Ailerons.....	8
Install the Aileron Servos & Pushrods.....	8
Join the Wing.....	11
BUILD THE FUSELAGE.....	12
Install the Horizontal Stabilizer, Elevator & Vertical Fin .....	12
Install the Elevator & Rudder Pushrods & Servos .....	14
Glow Engine, Fuel Tank & Radio Installation .....	15
Out-runner Motor, Battery & Radio Installation .....	18
FINISH THE MODEL .....	22
Install the Cowl.....	22
Final Assembly .....	22
Optional Landing Gear .....	24
Apply the Decals .....	25
GET THE MODEL READY TO FLY .....	25
Check the Control Directions .....	25
Set the Control Throws.....	25
Balance the Model (C.G.).....	26
Balance the Model Laterally .....	27
PREFLIGHT.....	27
Identify Your Model .....	27
Charge the Batteries .....	27
Balance the Propellers .....	27
Ground Check .....	27
Range Check.....	27
ENGINE / MOTOR SAFETY PRECAUTIONS .....	28
LITHIUM BATTERY HANDLING & USAGE .....	28
AMA SAFETY CODE (excerpts).....	28
CHECK LIST .....	29
FLYING .....	29
Fuel Mixture Adjustments.....	29
Takeoff .....	30
Flight.....	30
Landing.....	30

## INTRODUCTION

Congratulations on your purchase of one of the Great Planes Combat Class #2610 Fighters! The Combat Spitfire ARF is a great flying model suitable for combat flying or sport flying. Accommodations have been provided for both a glow engine and a brushless out-runner motor, and optional landing gear gives the sport flyer the comfort of paved runway landings.

For the latest technical updates or manual corrections to the Combat Spitfire ARF visit the Great Planes web site at [www.greatplanes.com](http://www.greatplanes.com). Open the "Airplanes" link, then select the Combat Spitfire ARF. If there is new technical information or changes to this model a "tech notice" box will appear in the upper left corner of the page.

## AMA

We urge you to join the AMA (Academy of Model Aeronautics) and a local R/C club. The AMA is the governing body of model aviation and membership is required to fly at AMA clubs. Though joining the AMA provides many benefits, one of the primary reasons to join is liability protection. Coverage is not limited to flying at contests or on the club field. It even applies to flying at public demonstrations and air shows. Failure to comply with the Safety Code (excerpts printed in the back of the manual) may endanger insurance coverage. Additionally, training programs and instructors are available at AMA club sites to help you get started the right way. There are over 2,500 AMA chartered clubs across the country. Contact the AMA at the address or toll-free phone number below.



**Academy of Model Aeronautics**  
5151 East Memorial Drive  
Muncie, IN 47302  
Tele: (800) 435-9262  
Fax (765) 741-0057  
Or via the Internet at:  
<http://www.modelaircraft.org>

**IMPORTANT!!!** Two of the most important things you can do to preserve the radio controlled aircraft hobby are to avoid flying near full-scale aircraft and avoid flying near or over groups of people.

## **PROTECT YOUR MODEL, YOURSELF & OTHERS...FOLLOW THESE IMPORTANT SAFETY PRECAUTIONS**

1. Your Combat Spitfire ARF should not be considered a toy, but rather a sophisticated, working model that functions very much like a full-size airplane. Because of its performance capabilities, the Combat Spitfire ARF, if not assembled and operated correctly, could possibly cause injury to yourself or spectators and damage to property.

2. You must assemble the model **according to the instructions**. Do not alter or modify the model, as doing so may result in an unsafe or unflyable model. In a few cases the instructions may differ slightly from the photos. In those instances the written instructions should be considered as correct.

3. You must take time to **build straight, true and strong**.

4. You must use an R/C radio system that is in first-class condition, and a correctly sized engine and components (fuel tank, wheels, etc.) throughout the building process.

5. You must correctly install all R/C and other components so that the model operates correctly on the ground and in the air.

6. You must check the operation of the model before **every** flight to insure that all equipment is operating and that the model has remained structurally sound. Be sure to check clevises or other connectors often and replace them if they show any signs of wear or fatigue.

7. If you are not an experienced pilot or have not flown this type of model before, we recommend that you get the assistance of an experienced pilot in your R/C club for your first flights. If you're not a member of a club, your local hobby shop has information about clubs in your area whose membership includes experienced pilots.

8. While this kit has been flight tested to exceed normal use, if the plane will be used for extremely high stress flying, such as racing, or if an engine larger than one in the recommended range is used, the modeler is responsible for taking steps to reinforce the high stress points and/or substituting hardware more suitable for the increased stress.

9. **WARNING:** The cowl included in this kit is made of fiberglass, the fibers of which may cause eye, skin and respiratory tract irritation. Never blow into a part to remove fiberglass dust, as the dust will blow back into your eyes. Always wear safety goggles, a particle mask and rubber gloves when grinding, drilling and sanding fiberglass parts. Vacuum the parts and the work area thoroughly after working with fiberglass parts.

We, as the kit manufacturer, provide you with a top quality, thoroughly tested kit and instructions, but ultimately the quality and flyability of your finished model depends on how you build it; therefore, we cannot in any way guarantee the performance of your completed model, and no representations are expressed or implied as to the performance or safety of your completed model.

**Remember: Take your time and follow the instructions to end up with a well-built model that is straight and true.**

## **DECISIONS YOU MUST MAKE**

This is a partial list of items required to finish the Combat Spitfire ARF that may require planning or decision making before starting to build. Order numbers are provided in parentheses.

### **Radio Equipment**

The Combat Spitfire ARF requires a minimum 4-channel radio system with four micro servos with a minimum of 35 oz.-in. [2.5 kg-cm] torque. If you are installing a glow engine, an additional micro servo is required for the throttle.

In addition, two 9" [230mm] servo extensions are required for the aileron servos. If you are using a radio system that does not support mixing functions, a Y-harness will also be required to connect the aileron servos to the receiver. Recommended part numbers are provided below:

- Futaba® S3115 Micro Precision Servo (FUTM0415)
- Futaba 9" Servo Extension J (FUTM3910)
- Futaba 6" Dual Servo Extension J (FUTM4130)

### **Power System Recommendations**

The recommended engine/motor size for the Combat Spitfire ARF is a .25 two-stroke engine or a RimFire™ C35-30-1450kV out-runner brushless motor. Engine and motor order numbers are provided below:

- O.S.® .25 FX Non-Ringed w/Muffler (OSMG0525)
- Great Planes RimFire 35-30-1450kV Out-runner Brushless Motor (GPMG4600)

If using the recommended brushless motor, the Great Planes SS-45 brushless ESC is required. Bullet connector adapters are also required. The adapters can be purchased pre-assembled, or the individual components can be purchased to make your own.

- Great Planes Silver Series 45A Brushless ESC 5V/2A BEC (GPMM1840)
- Great Planes 4mm Male to 3.5mm Female Bullet Connector Adapters (GPMM3123)

If you wish to make your own adapters, the following part numbers will be needed:

- Great Planes Gold Plated Bullet Connectors Female 3.5mm (GPMM3113)
- Great Planes Gold Plated Bullet Connectors Male 4mm (GPMM3114)
- W.S. Deans® Racing Silver Solder 1 oz. (WSDC4030)
- Hobbico® Soldering Iron 60 Watt (HCAR0776)

### Batteries & Charger

For a brushless motor installation, a 3200mAh 11.1V Lithium-Polymer battery pack or a 2000mAh 9.6V NiMH pack are recommended. Order numbers for the battery packs are provided below:

- Great Planes LiPo 3200mAh 11.1V 20C Discharge w/Balance (GPMP0623)
- Great Planes 8-Cell 9.6V 4/5 SC 2000mAh NiMH Custom (GPMP0352)

**Note:** A cell balancer is required for the LiPo battery pack listed above.

- Great Planes ElectriFly™ Equinox LiPo 1 to 5 Cell Balancer (GPMM3160)

A suitable charger is also required. The Great Planes PolyCharge4™ is designed for LiPo packs only, but is able to charge four LiPo packs simultaneously. The Great Planes Triton2™ charger will only charge one pack at a time, but is capable of charging NiCd, NiMH, LiPo, and lead acid batteries. Order numbers for both are provided below:

- Great Planes PolyCharge4 DC Only 4 Output LiPo Charger (GPMM3015)

or

- Great Planes ElectriFly Triton2 DC Comp Peak Charger (GPMM3153)

For an economical alternative to charge NiMH packs, we suggest:

- Great Planes ElectriFly Peak 400 DC 1-10C Peak Charger (GPMM3001)

### Propeller

If using the O.S. .25 FX glow engine or the Great Planes 35-30-1450kV RimFire out-runner motor, we suggest using a 9" x 6" propeller.

- APC 9" x 6" sport propeller (APCQ0906)

## ADDITIONAL ITEMS REQUIRED

### Required Hardware & Accessories

This is the list of hardware and accessories required to finish the Combat Spitfire ARF. Order numbers are provided in parentheses:

- R/C foam rubber (1/4" [6mm] – HCAQ1000, or 1/2" [13mm] – HCAQ1050)
- 3' [900mm] Standard silicone fuel tubing (GPMQ4131)

### Adhesives & Building Supplies

This is the list of Adhesives and Building Supplies that are required to finish the Combat Spitfire ARF:

- 1/2 oz. [15g] Thin Pro™ CA (GPMR6001)
- 1/2 oz. [15g] Medium Pro CA+ (GPMR6007)
- Pro 30-minute epoxy (GPMR6047)
- Masking tape (TOPR8018)
- Thread-locking compound (GPMR6060)
- Denatured alcohol (for epoxy clean up)
- Drill bits: 1/16" [1.6mm], 5/64" [2mm], 1/8" [3.2mm], 5/32" [4mm]
- Great Planes 10-Piece Metric Tap & Drill Set (GPMR8118, **Note:** 3mm tap & drill is needed for glow engine installation only)
- Tap handle (GPMR8120)
- R/C-56 canopy glue (JOZR5007)
- Small metal file
- #1 Hobby knife (HCAR0105)
- #11 Blades (5-pack, HCAR0211)
- Medium T-pins (100, HCAR5150)
- Top Flite® MonoKote® sealing iron (TOPR2100)
- Top Flite Hot Sock™ iron cover (TOPR2175)
- Liquid dish soap

### Optional Supplies & Tools

Here is a list of optional tools that will help you build the Combat Spitfire ARF:

- 1/2 oz. [15g] Thick Pro CA- (GPMR6013)
- 2 oz. [57g] spray CA activator (GPMR6035)
- 4 oz. [113g] aerosol CA activator (GPMR6034)
- CA applicator tips (HCAR3780)
- CA debonder (GPMR6039)
- Pro 6-minute epoxy (GPMR6045)
- Epoxy brushes 6, (GPMR8060)
- Mixing sticks (GPMR8055)
- Mixing cups (GPMR8056)
- Pliers with wire cutter (HCAR0630)
- Switch & Charge Jack mounting set (GPMM1000)
- Panel Line Pen (TOPQ2510)

- Rotary tool such as Dremel®
- Rotary tool reinforced cut-off wheel (GPMR8020)
- Servo horn drill (HCAR0698)
- Hobby Heat™ micro torch (HCAR0750)
- Dead Center™ Engine Mount Hole Locator (GPMR8130)
- Precision Magnetic Prop Balancer (TOPQ5700)
- AccuThrow™ deflection gauge (GPMR2405)
- CG Machine™ (GPMR2400)
- Hobbico flexible 18" ruler stainless steel (HCAR0460)
- Top Flite MonoKote trim seal iron (TOPR2200)
- Top Flite MonoKote heat gun (TOPR2000)
- Hobbico Pin Vise 1/16" collet w/6 bits (HCAR0696)
- Hobbico 7-Piece ball tip hex L-wrench Metric (HCAR0521)
- Great Planes clevis installation tool (GPMR8030)
- X-Acto® Extra Hands double clip (XACR4214)

### Building Stand



A building stand or cradle comes in handy during the build. We use the Robart Super Stand II (ROBP1402) for all our projects in R&D and it can be seen in pictures throughout this manual.

### IMPORTANT BUILDING NOTES

- When you see the term **test fit** in the instructions, it means that you should first position the part on the assembly **without using any glue**, then slightly modify or **custom fit** the part as necessary for the best fit.
- Whenever the term **glue** is written you should rely upon your experience to decide what type of glue to use. When a specific type of adhesive works best for that step, the instructions will make a recommendation.
- Whenever just **epoxy** is specified you may use **either** 30-minute (or 45-minute) epoxy **or** 6-minute epoxy. When 30-minute epoxy is specified it is **highly** recommended that you use only 30-minute (or 45-minute) epoxy, because you will need the working time and/or the additional strength.

- **Photos** and **sketches** are placed **before** the step they refer to. Frequently you can study photos in following steps to get another view of the same parts.

- The stabilizer and wing incidences and engine thrust angles have been factory-built into this model. However, some technically-minded modelers may wish to check these measurements anyway. To view this information visit the web site at [www.greatplanes.com](http://www.greatplanes.com) and click on "Technical Data." Due to manufacturing tolerances which will have little or no effect on the way your model will fly, please expect slight deviations between your model and the published values.

### ORDERING REPLACEMENT PARTS

Replacement parts for the Great Planes Combat Spitfire ARF are available using the order numbers in the **Replacement Parts List** that follows. The fastest, most economical service can be provided by your hobby dealer or mail-order company.

To locate a hobby dealer, visit the Hobbico web site at [www.hobbico.com](http://www.hobbico.com). Choose "Where to Buy" at the bottom of the menu on the left side of the page. Follow the instructions provided on the page to locate a U.S., Canadian or International dealer.

Parts may also be ordered directly from Hobby Services by calling (217) 398-0007, or via facsimile at (217) 398-7721, but full retail prices and shipping and handling charges will apply. Illinois and Nevada residents will also be charged sales tax. If ordering via fax, include a Visa® or MasterCard® number and expiration date for payment.

Mail parts orders and payments by personal check to:

Hobby Services  
3002 N Apollo Drive, Suite 1  
Champaign IL 61822

Be certain to specify the order number exactly as listed in the **Replacement Parts List**. Payment by credit card or personal check only; no C.O.D.

If additional assistance is required for any reason contact Product Support by e-mail at [productsupport@greatplanes.com](mailto:productsupport@greatplanes.com), or by telephone at (217) 398-8970.

**Description**  
Missing parts  
Instruction manual  
Full-size plans  
Kit parts listed below

**How to Purchase**  
Contact Product Support  
Contact Product Support  
Not available  
Hobby Supplier

**Replacement Parts List**

- GPMA2821 .....Wing Set
- GPMA2822 .....Fuse Kit
- GPMA2823 .....Tail Set
- GPMA2824 .....Cowl
- GPMA2825 .....Canopy
- GPMA2826 .....Landing Gear
- GPMA2827 .....Engine Mount
- GPMA2828 .....Decal Sheet
- GPMQ4515 .....2-1/4" White Plastic Spinner

**METRIC CONVERSIONS**

1" = 25.4mm (conversion factor)

1/64" = .4mm	3/4" = 19.0mm
1/32" = .8mm	1" = 25.4mm
1/16" = 1.6mm	2" = 50.8mm
3/32" = 2.4mm	3" = 76.2mm
1/8" = 3.2mm	6" = 152.4mm
5/32" = 4.0mm	12" = 304.8mm
3/16" = 4.8mm	18" = 457.2mm
1/4" = 6.4mm	21" = 533.4mm
3/8" = 9.5mm	24" = 609.6mm
1/2" = 12.7mm	30" = 762.0mm
5/8" = 15.9mm	36" = 914.4mm

**COMMON ABBREVIATIONS**

- Fuse = Fuselage
- Stab = Horizontal Stabilizer
- Fin = Vertical Fin
- LE = Leading Edge
- TE = Trailing Edge
- LG = Landing Gear
- Ply = Plywood
- " = Inches
- mm = Millimeters
- SHCS = Socket Head Cap Screw
- ESC = Electronic Speed Control

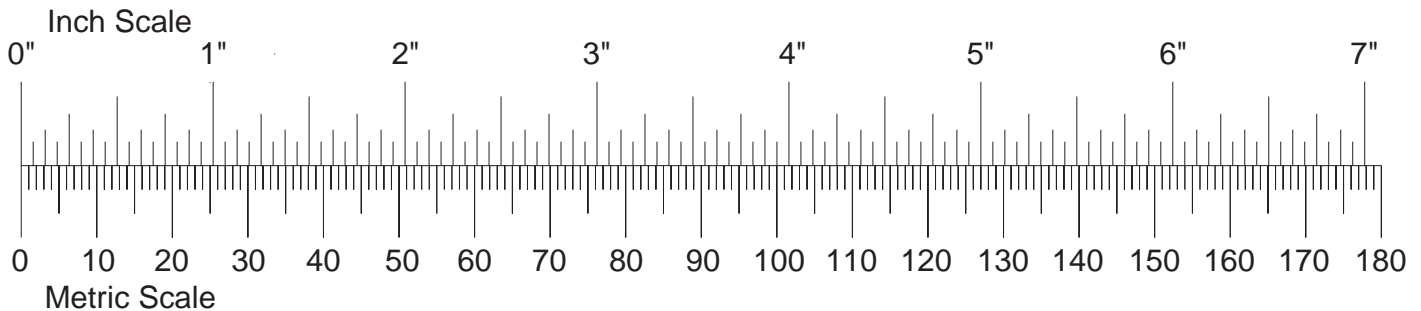

## KIT INSPECTION

Before starting to build, take an inventory of this kit to make sure it is complete and inspect the parts to make sure they are of acceptable quality. If any parts are missing or are not of acceptable quality, or if you need assistance with assembly, contact **Product Support**. When reporting defective or missing parts, use the part names exactly as they are written in the Kit Contents list.

**Great Planes Product Support:**  
3002 N Apollo Drive, Suite 1  
Champaign, IL 61822  
Telephone: (217) 398-8970, ext. 5  
Fax: (217) 398-7721  
E-mail: [airsupport@greatplanes.com](mailto:airsupport@greatplanes.com)

## KIT CONTENTS

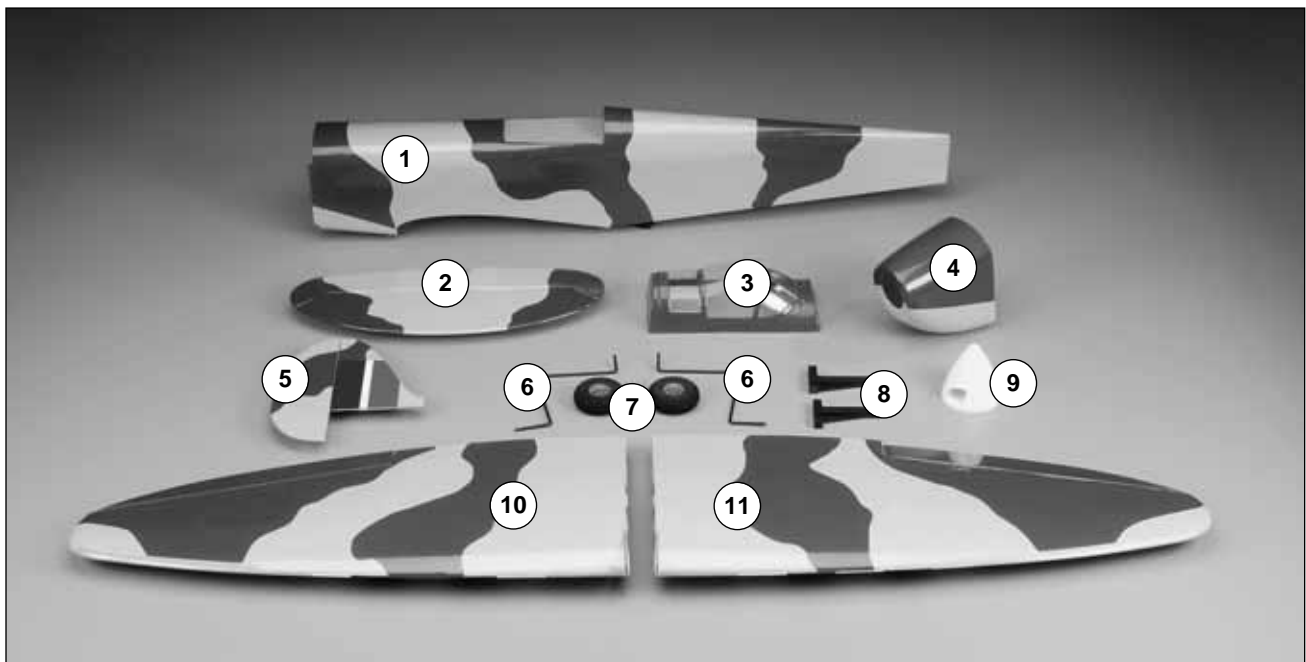

### Kit Contents

- |   |                                 |
|---|---------------------------------|
| 1 Fuselage                                      | 8 Engine Mount                  |
| 2 Horizontal Stabilizer & Elevator Halves (L&R) | 9 Spinner                       |
| 3 Canopy  | 10 Right Wing Panel (w/Aileron) |
| 4 Cowl  | 11 Left Wing Panel (w/Aileron)  |
| 5 Vertical Fin & Rudder                         |                                 |
| 6 Landing Gear (L&R)                            |                                 |
| 7 Main Wheels (2)                               |                                 |



## PREPARATIONS

1. If you have not done so already, remove the major parts of the kit from the box and inspect for damage. If any parts are damaged or missing, contact **Product Support** at the address or telephone number listed in the "**Kit Inspection**" section on page 7.

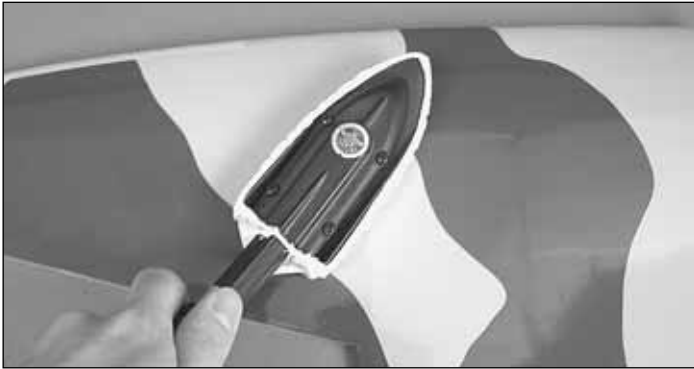

2. Remove the tape and separate all the control surfaces. Use a covering iron with a covering sock on medium/high heat to tighten the covering if necessary. Apply pressure over sheeted areas to **thoroughly** bond the covering to the wood.

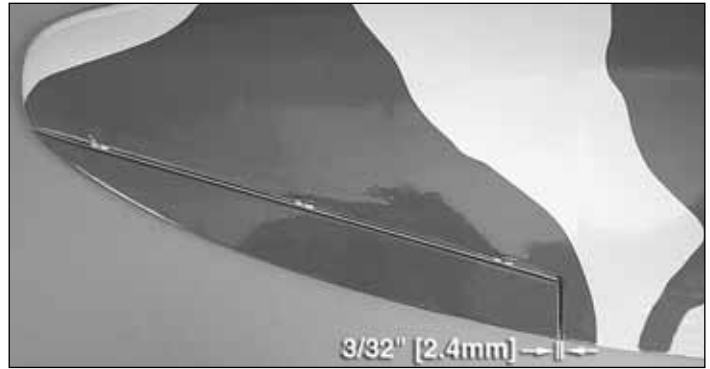

2. Join the ailerons to the wing panels. Position the ailerons so that there is a 3/32" [2.4mm] gap between the inside ends of the ailerons and the wing panels.
3. Remove the pins in the hinges. Adjust the ailerons so there is a small gap between the LE of the aileron and the wing. The gap should be small, just enough to see light through the gap or to slip a piece of paper through.

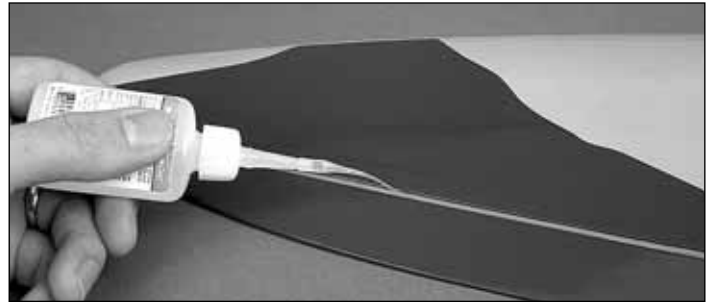

4. Apply six drops of thin CA to the top and bottom of each hinge without using accelerator. After the CA glue has hardened, confirm that the ailerons are secure by pulling on them and deflecting them up and down.

## BUILD THE WING

### Install the Ailerons

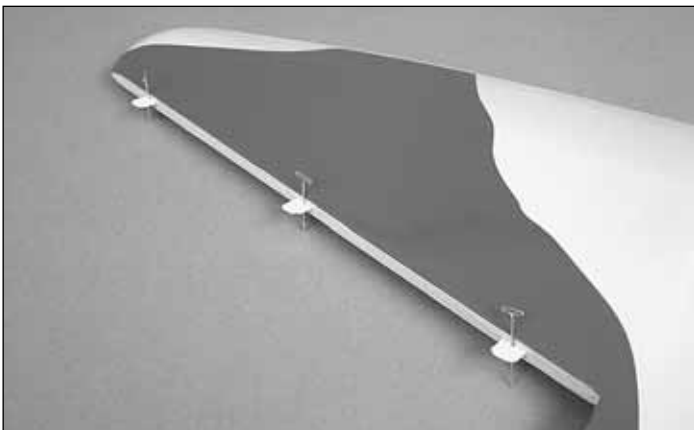

1. Test fit a CA hinge into each of the hinge slots in the **wing panels** and **ailerons**. If necessary, enlarge the slots with a hobby knife. When satisfied with the fit, insert a CA hinge halfway into each hinge slot in the wing panels. Push a pin through the middle of each hinge to keep them centered.

### Install the Aileron Servos & Pushrods

*There are servo bays in both the top and bottom of the wing panels. If you plan to install the optional landing gear (sport flying), install the servos on the bottom of the wings. If you plan to use the Combat Spitfire ARF for combat flying, you may choose not to install the optional landing gear. In this case, install the servos into the top of the wing panels to protect the servos during belly landings. The assembly procedure is the same for both.*



1. Locate and remove the covering from the **aileron servo bays** on the bottom (or top) of the wing panels using a sharp hobby knife.



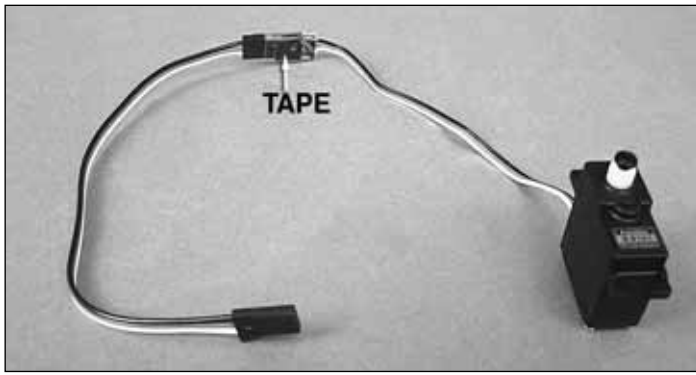

2. Attach a 9" [230mm] servo extension to each aileron servo. Secure the connection with tape or heat-shrink tubing (not included).



4. Install the rubber grommets and eyelets that were included with the servo. Mount the servo in the servo bay and drill a 1/16" [1.6mm] hole through each mounting hole location. Remove the servo and install and remove a servo mounting screw (included with your servo) into each hole. Apply a couple drops of thin CA into the holes to harden the wood. When the CA has hardened completely, install the servo into the servo bay using the servo mounting screws with the servo spline facing forward.

5. Repeat steps 3 and 4 for the other wing panel.

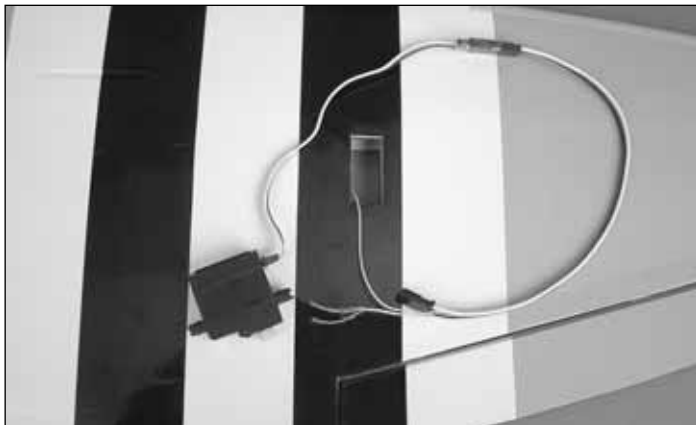

3. Pull the outside end of the servo wire string through the servo bay opening. Tie the string to the end of the servo extension. The other end of the string is taped to the root rib of the wing panel. Remove the tape and use the string to pull the servo wire through the wing panel.

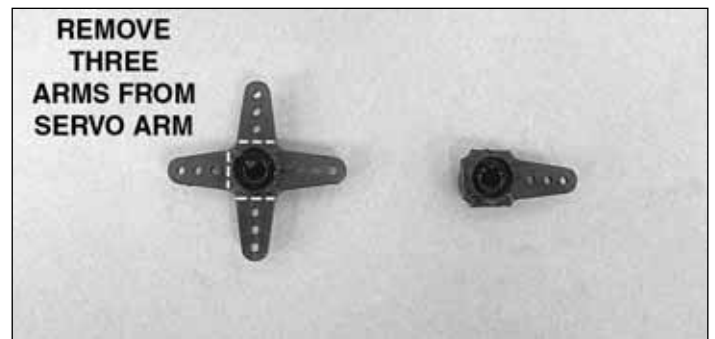

6. Cut three arms from a four-armed servo arm for each servo.



7. Use your radio system to center the servos. Install the servo arms perpendicular to the servo case pointing to the wing tips.

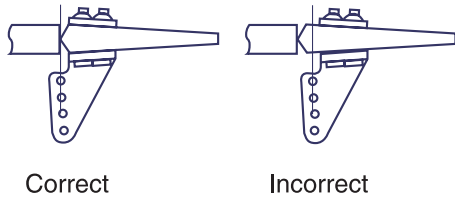

❑ 8. Place a control horn onto each aileron in line with the outer hole of the servo arm. We used a ruler as a straightedge. Position the horn so that the holes in the horn are centered above the aileron hinge line. Use a fine, felt-tip pen or a T-pin to mark the locations of the control horn screws onto the ailerons.

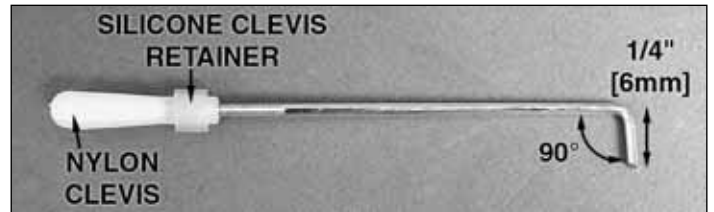

❑ 10. Locate a 2mm x 120mm pushrod wire threaded on one end. Screw a nylon clevis and a silicone clevis retainer onto the threaded end of the wire 20 full turns. Install the clevis onto the outer hole of the control horn. (If necessary, enlarge the hole with a 5/64" [2mm] bit.) Center the servo arm (perpendicular to the servo case) and center the aileron (use tape or small clamps to hold it in place). Mark the location where the wire crosses the outer hole in the servo arm. Bend the wire 90 degrees at this mark and cut the excess wire 1/4" [6mm] beyond the bend. Repeat this step for the other pushrod.

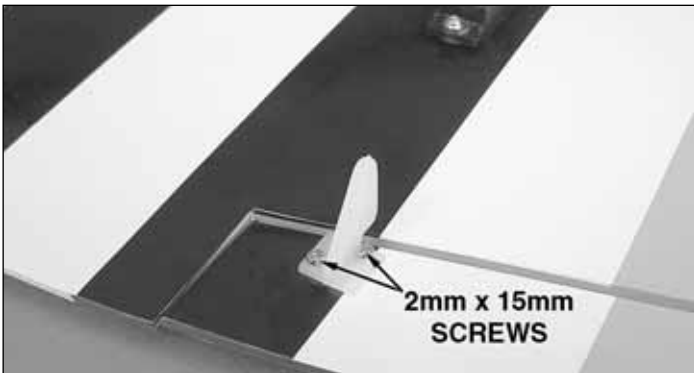

❑ 9. Drill holes at your marks through the ailerons using a 5/64" [2mm] drill bit. Install the control horns using 2mm x 15mm machine screws and the control horn backplates. The ends of the screws can be cut flush with the backplates.

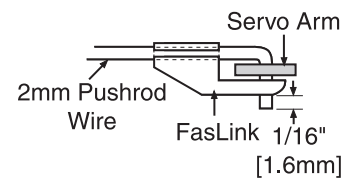
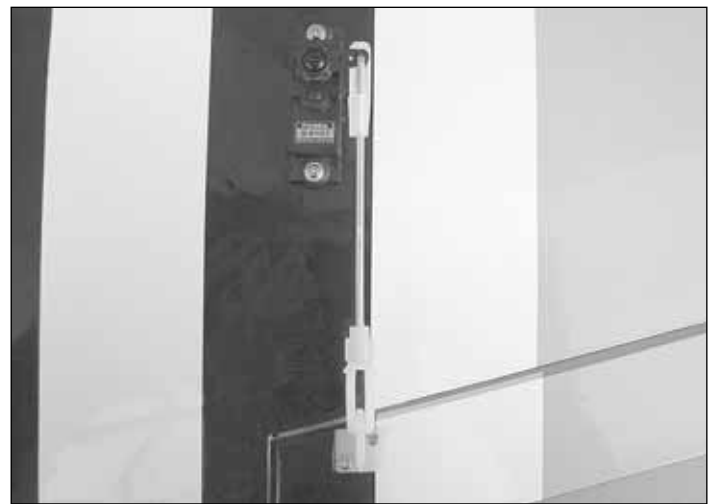

❑ 11. Enlarge the outer hole in the servo arm with a Hobbico Servo Horn Drill or a 5/64" [2mm] drill bit. Attach the clevis to the control horn, slide the silicone clevis retainer over the clevis and install the 90° bend in the wire into the servo arm and retain it with a nylon FasLink. Connect the pushrod for the other wing panel the same way.

## Join the Wing

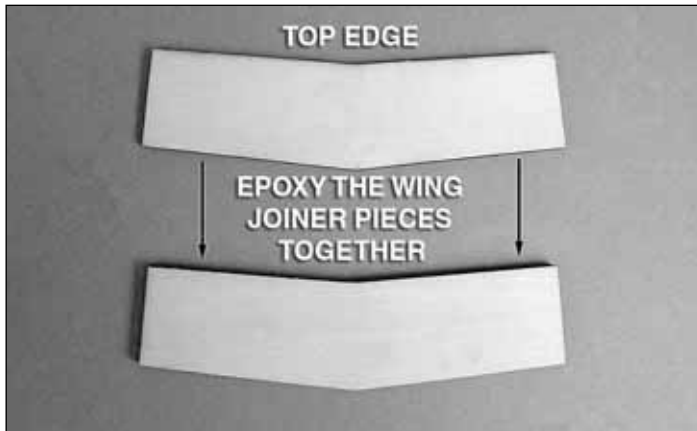

1. Locate the two plywood **wing joiners**. Mix up a small amount of epoxy and laminate the two pieces together. Join the pieces together, being sure the edges are as flush as possible. Use alcohol to wipe away any excess epoxy. Make note of the top side of the joiner. This should face the top of the wing panels when installed.

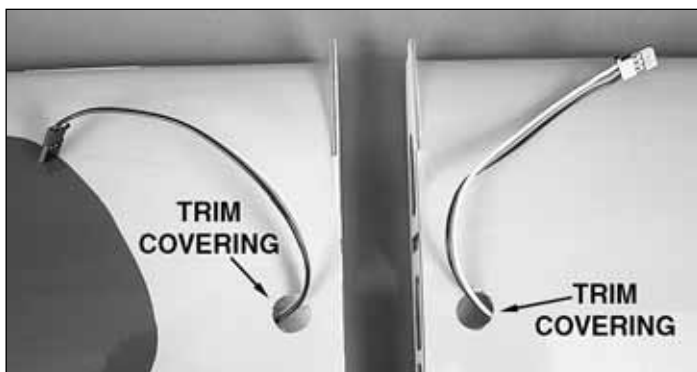

2. Trim the covering from the round servo wire exit holes on the tops of the wing panels. Feed the servo wires through the holes.



3. Test fit the joiner into both wing halves. The joiner should fit slightly loose to allow room for epoxy. If the joiner is too snug, sand the face, top or bottom as necessary for the proper fit.

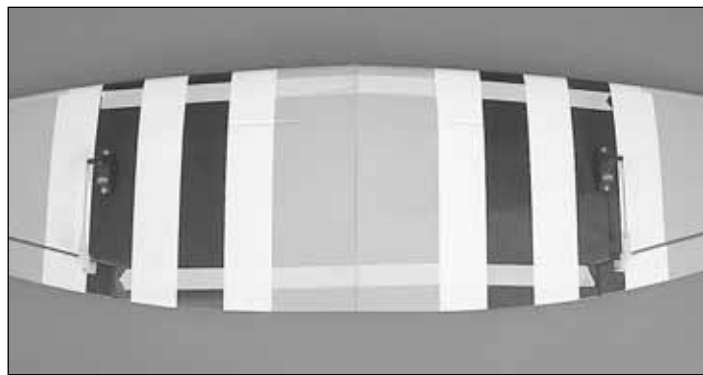

4. Trim the covering that overlaps onto the root ribs of each wing panel. Mix approximately 1/2 oz [15cc] of 30-minute epoxy. Apply a liberal amount of epoxy into the wing joiner pocket of each wing, the root rib of each wing and the joiner. Insert the wing joiner into the right wing panel and then slide the left panel onto the joiner. Push the two halves together firmly, making sure there are no gaps anywhere between the wing panels. Clean any excess epoxy from the wing surface with alcohol. Hold the wings together with masking tape until the epoxy has completely cured.



5. Locate and remove the covering from the wing bolt holes near the TE of the wing.

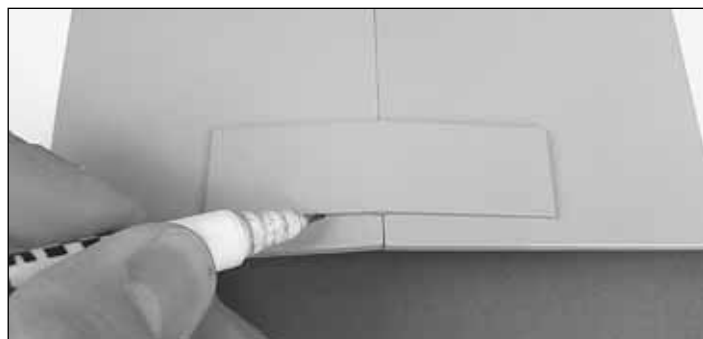

6. Align the **wing bolt plate** over the holes on the underside of the wing. There is a shallow perforation on the uncovered side of the wing bolt plate to allow you to bend the plate to match the dihedral of the wing. With the wing bolt plate centered over the holes, use a fine, felt-tip pen to trace around the plate onto the wing.



7. Trim the covering just inside your lines. Wipe away the lines with alcohol and glue the wing bolt plate to the wing. Continue the wing bolt holes through the wing bolt plate with a 5/32" [4mm] drill bit. A wood backer piece while drilling will help ensure clean-edged holes in the backplate.



### HOW TO CUT COVERING FROM Balsa

Use a soldering iron to cut the covering from wing. The tip of the soldering iron doesn't have to be sharp, but a fine-tip does work best. Allow the iron to heat fully.

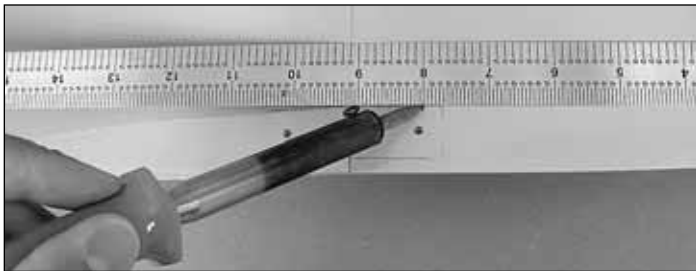

Use a straightedge to guide the soldering iron at a rate that will just melt the covering and not burn into the wood. The hotter the soldering iron, the faster it must travel to melt a fine cut. Peel off the covering.

## BUILD THE FUSELAGE

### Install the Horizontal Stabilizer, Elevator & Vertical Fin



1. Locate and remove the covering away from the fuselage for the **horizontal stabilizer** and **vertical fin**.

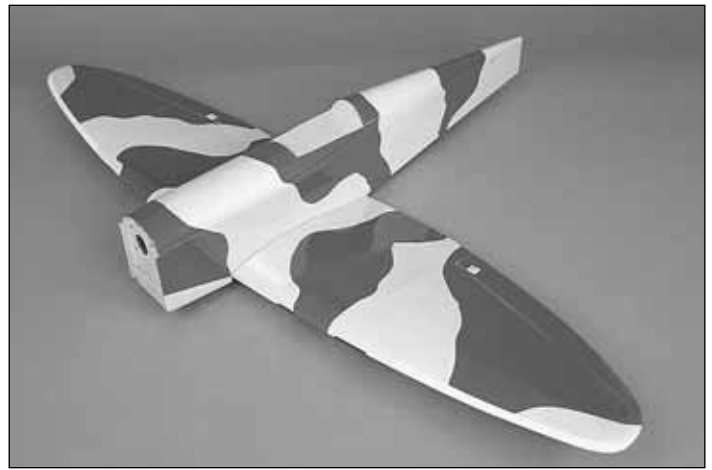

2. In order to properly align the stab in the fuse, the wing will need to be temporarily installed. Attach the wing using two 3mm x 25mm Phillips machine screws and two 3mm flat washers.

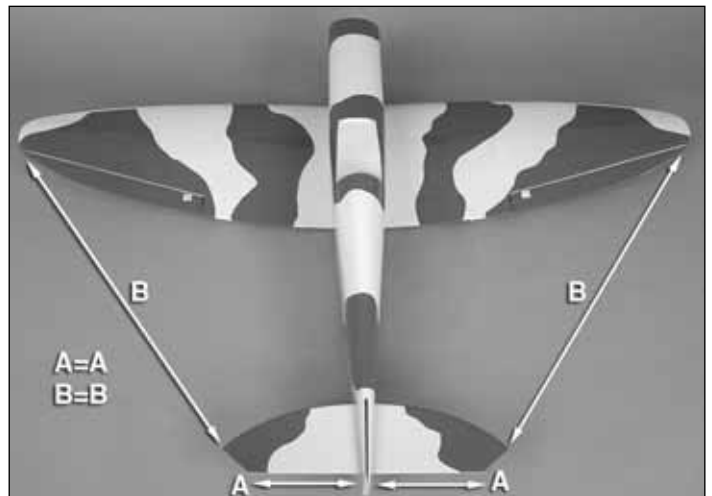

3. Insert the stab into the fuse. Position the stab so it is centered left and right in the fuse and the tips of the stab are an equal distance from the wing tips. Trace around the stab where it meets the fuse with a felt-tip pen.

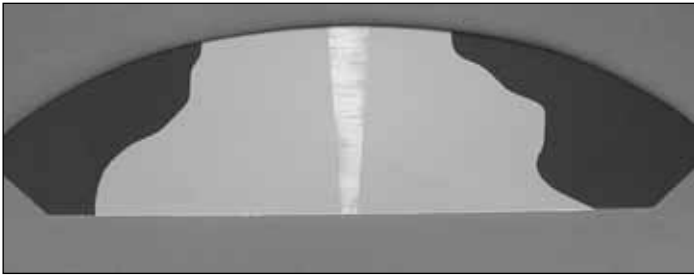

4. Cut the covering away 1/16" [1.6mm] inside the lines you drew.

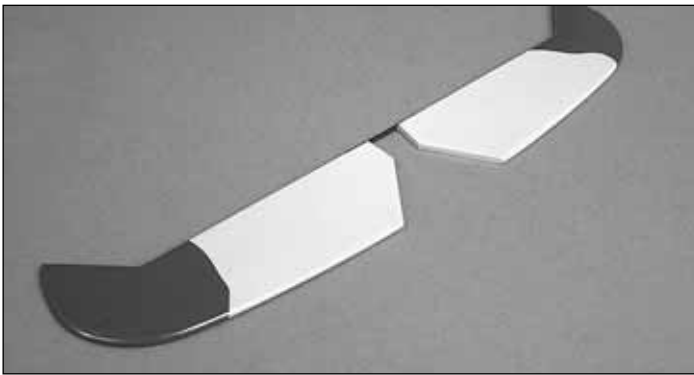
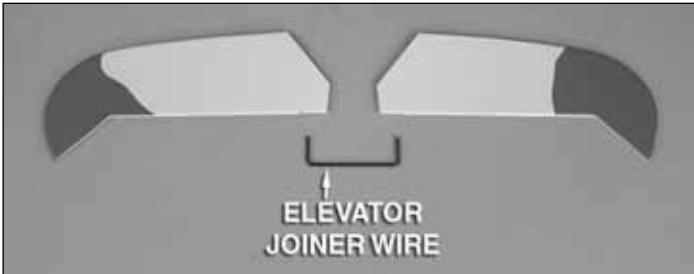

5. Before putting the **elevator joiner wire** into the stab slot, trim the covering from the grooves and elevator joiner wire holes at the TE of the **elevator halves**. Fit the elevator joiner wire into the elevators and lay them down on a flat work surface. Both elevators should lay flat. If not, gently twist the joiner wire until they do (remove the elevator joiner wire from the elevator halves before bending).



6. Insert the elevator joiner wire into the back of the stab slot along with the stab. Stand back several feet and view the model from the back. Confirm that the stab is aligned parallel with the wing. If necessary, lightly sand the **stab pocket** or add weight to one side of the stab to bring them parallel. When satisfied, glue the stab in place with epoxy. For a strong joint, apply epoxy to the inside of the stab pocket and onto the stab itself. Wipe away any excess epoxy with alcohol and let the epoxy cure undisturbed. Be sure that the epoxy does not contact the joiner wire.

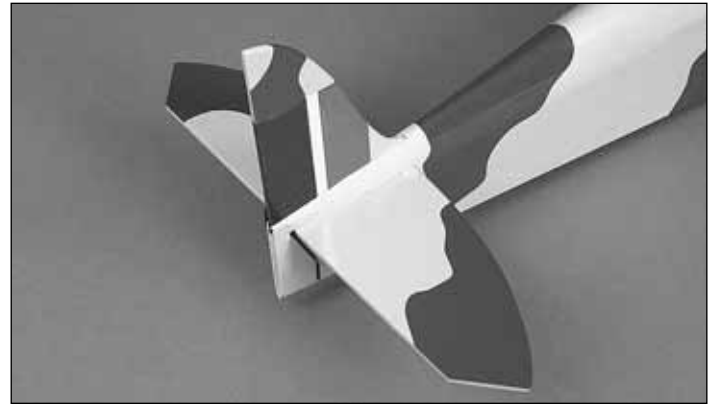

7. Fit the **vertical fin** into the fuse and trace around it onto the fin. Remove the fin and cut the covering away slightly beneath the lines you drew (leave the covering on the TE of the fin in place). Use epoxy to glue the fin in position.

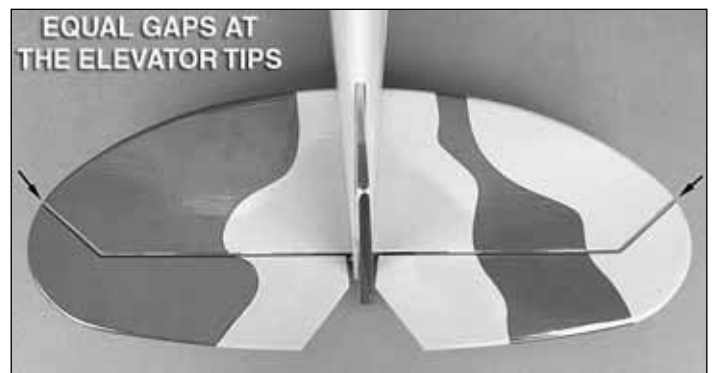

8. Insert a hinge half way into each hinge slot in the stab and keep them centered with a pin. Coat the ends of the elevator joiner wire with epoxy. Join the elevator halves to the stab by first fitting the joiner wire ends into the mating holes in the elevators, then fitting the CA hinges into place. Before wicking thin CA glue into the hinges, position the elevator halves so that the gaps between the stab ends and the elevator tips are equal.

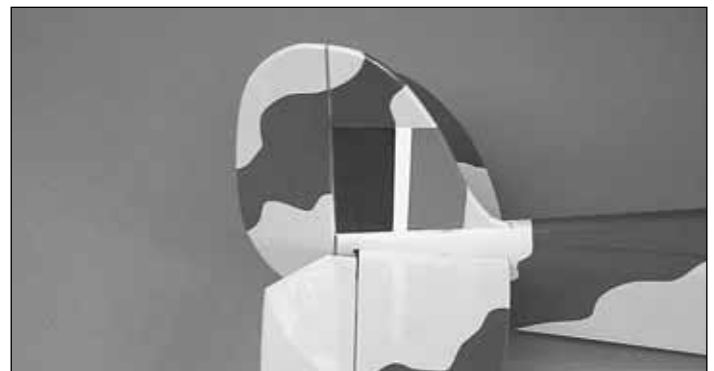

9. Join the **rudder** to the fuse and fin with CA hinges.



## Install the Elevator & Rudder Pushrods & Servos

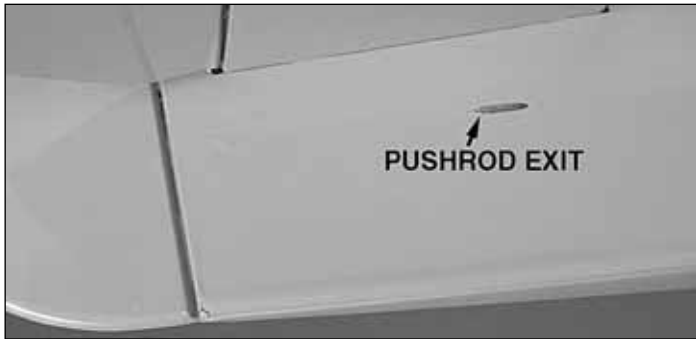

1. Locate and remove the covering from the pushrod exits on both sides of the fuse beneath the stab.

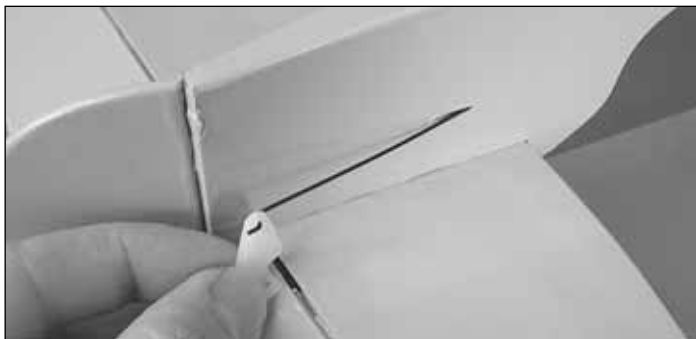

2. Insert one of the 19-3/4" [502mm] pushrod wires through the left pushrod exit slot into the fuse. Hook a nylon control horn onto the Z-bend in the pushrod wire. Align the control horn onto the underside of the left elevator half and position the holes over the hinge line at a slight inward angle matching the angle of the pushrod. When satisfied, mark the locations for the control horn mounting screws. Drill the holes using a 5/64" [2mm] drill bit and install the control horn with two 2mm x 15mm machine screws and a control horn backplate.

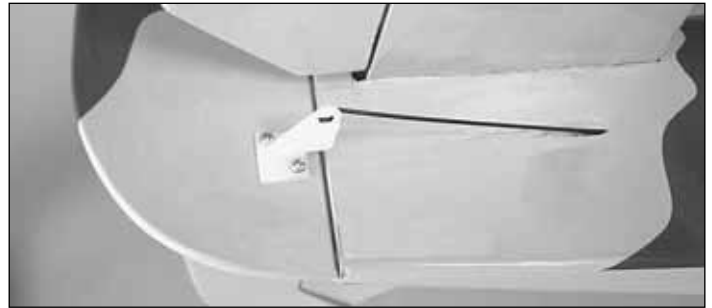

3. With the other 19-3/4" [502mm] pushrod, install a control horn on the right side of the rudder in the same manner.

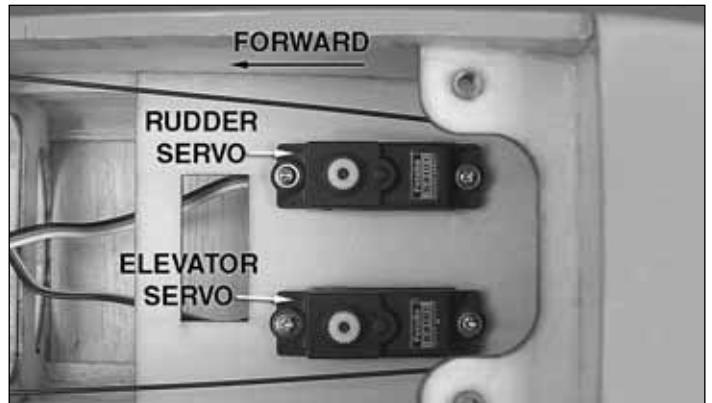

4. Using the hardware supplied with the servos, install the elevator and rudder servo into the fuse with the servo splines facing forward. Be sure to reinforce the servo mounting screw holes with thin CA.

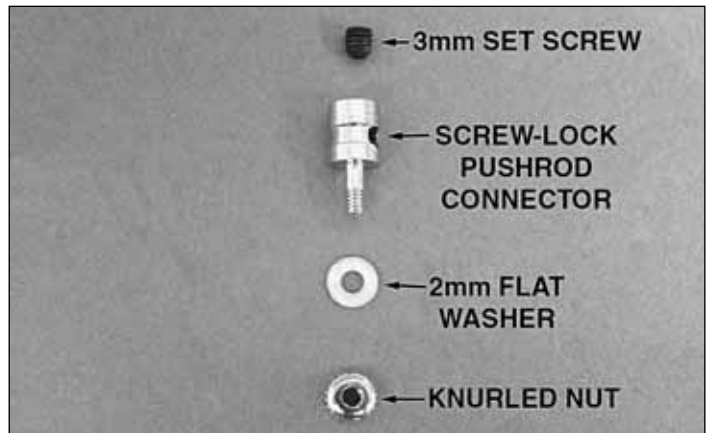

5. As you did with the ailerons, cut three arms from the elevator and rudder servo arms. Enlarge the outer hole of each

servo arm with a 5/64" [2mm] drill bit. Install a screw-lock pushrod connector into the outer hole of each servo arm. Tighten them to the servo arms with a 2mm flat washer, knurled nut, and **thread-locking compound**. The nut should be snug against the washer but still allow the pushrod connector to rotate freely in the servo arm hole. Slide the pushrod wires through the screw-lock pushrod connectors and attach the servo arms to the servos (perpendicular to the servo case pointing out) using the servo arm screws included with the servos. With the elevators and rudder centered, thread a 3mm set screw with thread-locking compound into the tops of the pushrod connectors and tighten it against the pushrod wires. Cut away the excess pushrod wires 1/4" [6mm] beyond the pushrod connectors.

## Glow Engine, Fuel Tank & Radio Installation

The Combat Spitfire ARF is designed to be flown with a .25 glow engine or an out-runner brushless motor. If you plan to install a brushless motor, skip this section as it only contains information relevant to installing a glow engine.

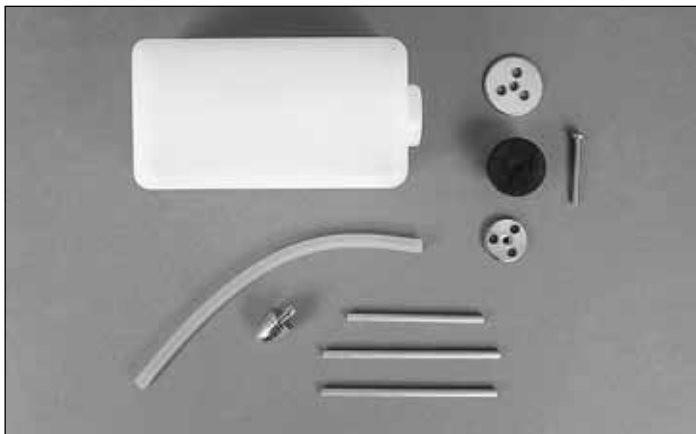

❑ 1. Remove the stopper from the fuel tank and shake out the contents.

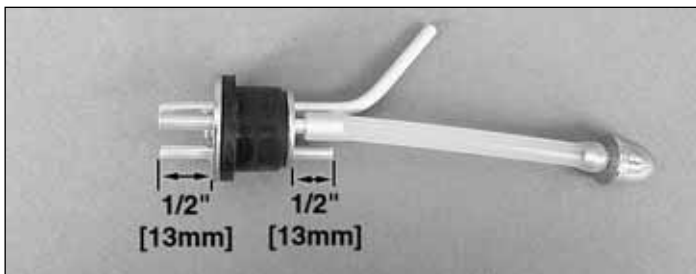

❑ 2. The fuel tank can be assembled as a two line system consisting of a vent (pressure) line to the muffler and a carb line. Filling and emptying of the tank would need to be done through the carb line, or an optional fuel fill valve (not included). The tank can also be assembled as a three line system having a vent line, carb line, and fill line. If installing a fill line, puncture the third hole in the top of the stopper above the sealed off fuel tube hole. The fill and carb lines should extend out 1/2" [13mm] beyond the stopper and the vent line should be bent upwards and left uncut. With the tubes installed in the stopper, fit the stopper plates loosely in place with the 3mm x 25mm phillips screw to hold the assembly together.

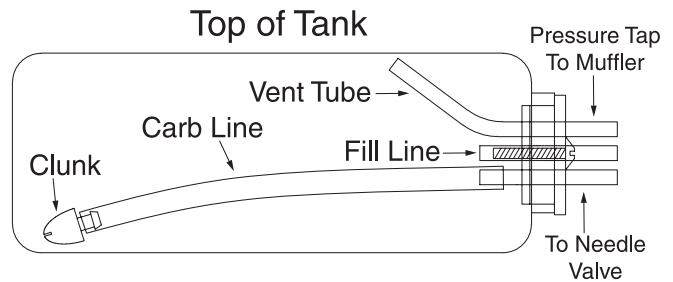

❑ 3. Fit the stopper assembly into the tank with the vent line pointing toward the top of the tank, but not touching. The fuel tubing and clunk (fuel pickup) on the carb line should almost reach the back of the tank but not touch. The clunk must be able to move freely inside the tank when assembled. Adjust the length of the fuel tubing accordingly. If you wish to use the fill line to drain the tank, attach a length of fuel tubing and an additional fuel clunk (not included) to the fill line inside the tank. When satisfied, tighten the 3mm x 25mm screw in the stopper to secure it in place (do not overtighten). Mark the side of the tank that must face up when installed in the plane, and we also suggest marking the tubes in the stopper.

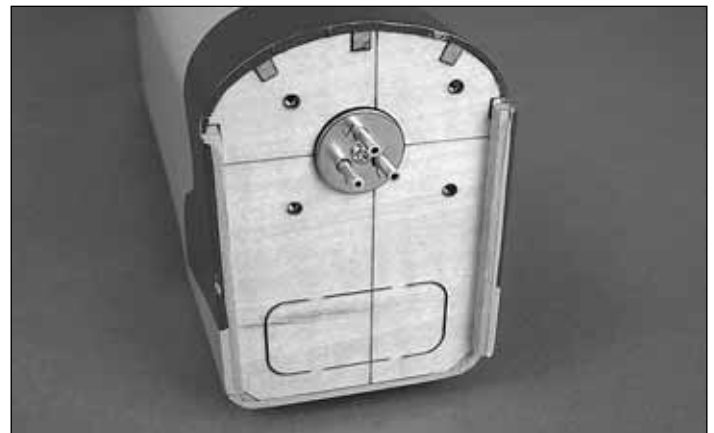

❑ 4. Insert the tank into the fuse with the correct side facing up. The neck of the tank should pass through the hole in the firewall.



❑ 5. Cut a piece from the included 6mm x 6mm stick to fit between the spars behind the fuel tank in order to secure the tank in place as shown. When satisfied with the fit, use CA to glue the stick in place.



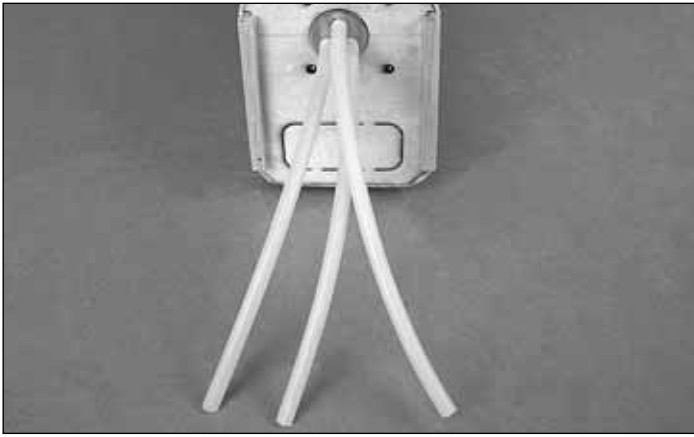

6. Attach a 6" [150mm] piece of fuel line to each of the metal tubes in the fuel tank.

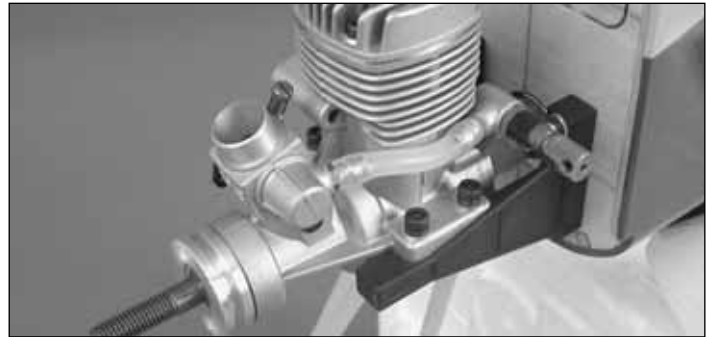
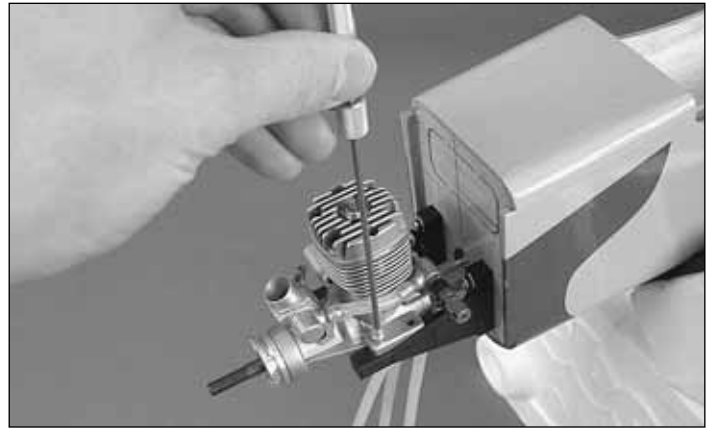

8. Position the front of the engine drive washer 3-3/4" [95mm] from the firewall. Mark the location of the engine mount holes onto the engine mount halves using a Dead Center™ Hole Locator (GPMP8130). Remove the engine from the mount and use a 3mm tap and drill set to create threads in the four mounting holes. Attach the engine to the mount using four 3mm x 20mm SHCS, four 3mm lock washers, and four 3mm flat washers.

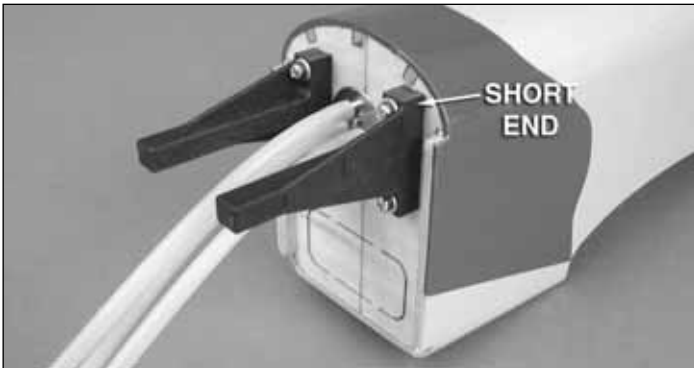

7. Using four 3mm x 16mm machine screws, four 3mm lock washers and four 3mm flat washers, attach the engine mount halves inverted to the firewall. The short end of the engine mount halves should face up.

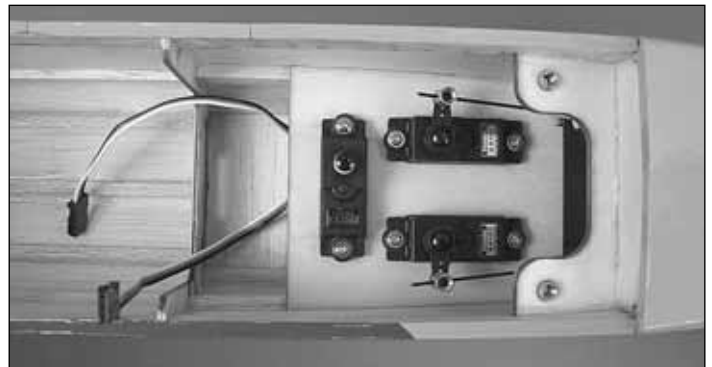
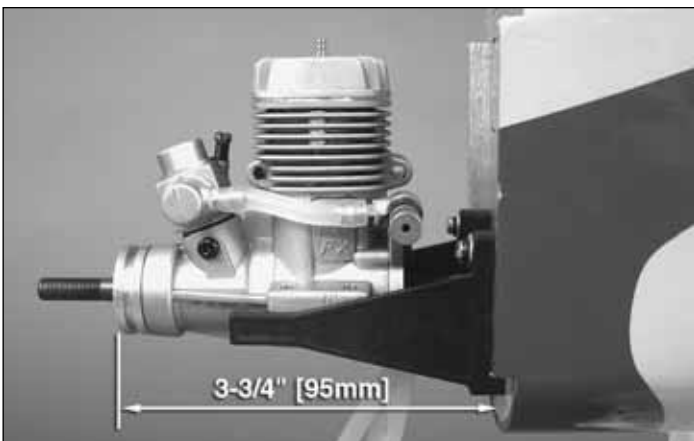

9. Install the throttle servo into the **throttle servo bay** with the servo splines facing the same side of the plane as the throttle arm on the engine.

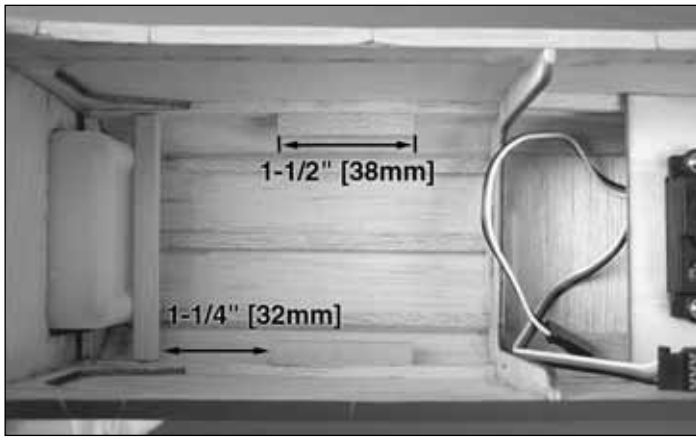

10. Cut two 1-1/2" [38mm] pieces from the included 6mm x 6mm stick. Glue them to the **fuse stringers** flush with the fronts approximately 1-1/4" [32mm] behind the stick holding the fuel tank in place.

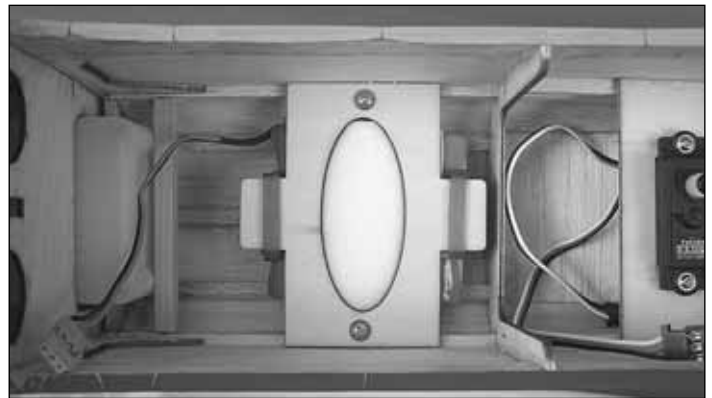

12. Fit the receiver tray onto the 6mm x 6mm sticks you glued in step 9. Drill a 5/64" [2mm] hole at each end of the receiver tray into the sticks. Attach the tray to the sticks using two 2.5mm x 10mm self-tapping screws. Cut another piece of foam rubber to fit your receiver. Secure the receiver to the tray with the foam rubber between them using the other rubber band.

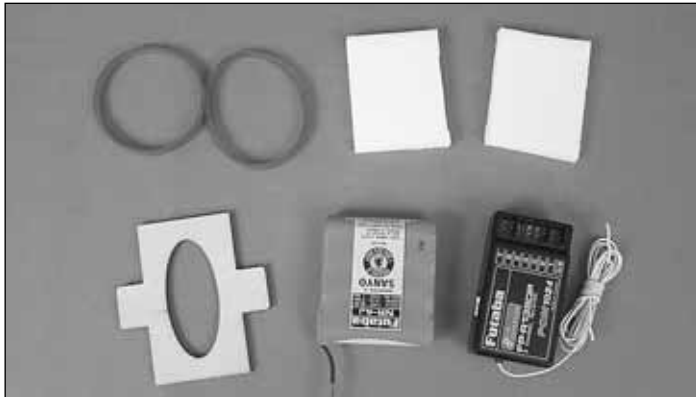

11. Prepare the radio installation by locating the **receiver tray**, two rubber bands, receiver, and receiver battery. You will also need some 1/4" [6mm] or 1/2" [13mm] foam rubber (not included). Cut a piece of foam rubber that fits your receiver battery pack and sandwich it between the pack and the receiver tray. With the pack centered on the top of the tray (tray is shown upside-down), use a rubber band looped onto the tray tabs to strap the pack in place as shown.

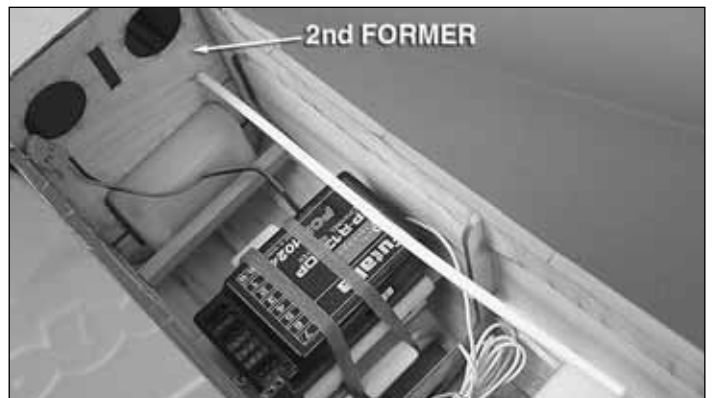
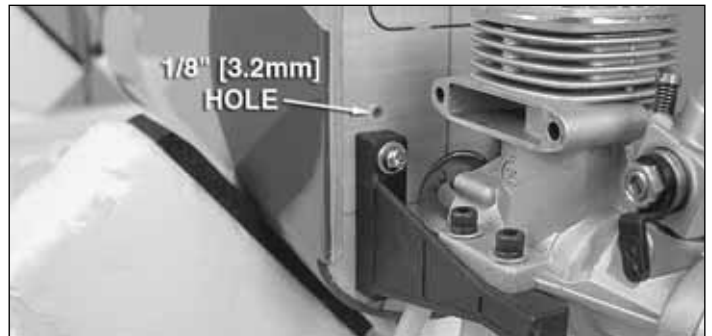

13. Drill a 1/8" [3.2mm] hole through the firewall inline with the throttle arm on the engine. **Important!! Do not drill into**

**the fuel tank!** The bottom of the tank is 7/8" [22mm] above the top of the cooling hole cutout. To allow for some error, be sure that your hole is 5/8" [16mm] or closer to the cooling hole cutout. If in doubt, remove the tank before drilling your hole. Drill a hole through the second fuse former inline with the first (a long drill bit is helpful here). Insert the 1/8" x 9-5/8" [3mm x 245mm] nylon pushrod tube through the holes. Use CA to glue the tube flush with the front of the firewall.

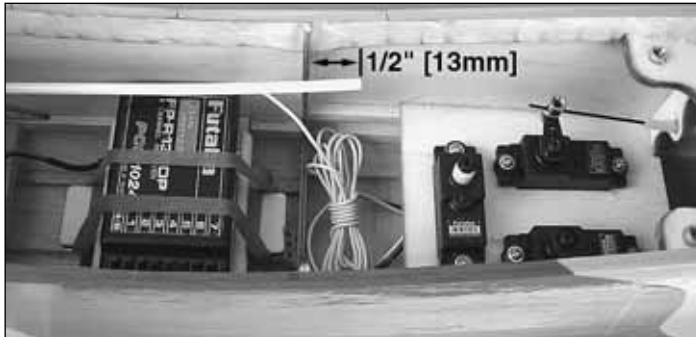

14. Cut off the excess pushrod tube 1/2" [13mm] behind the third fuse former.

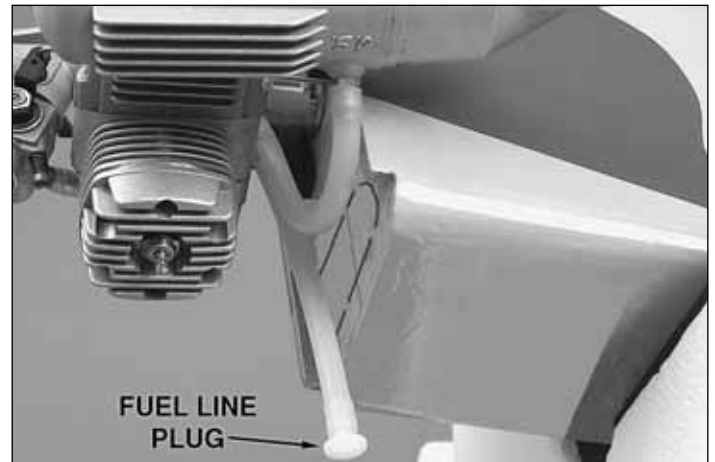

16. Run a bead of medium or thick CA glue along the brushless motor cooling hole cutout lines. Trim the fuel tubing to length and connect the vent line to the muffler and the carb line to the fuel inlet on the needle valve. A plastic fuel line plug has been provided to plug the fill line if you installed one.



15. Install the .039" x 13-3/4" [1mm x 350mm] throttle pushrod with Z-bend into the outer pushrod and connect the Z-bend to your engine throttle arm (you may need to remove the arm from the carburetor to do this). Install a screw-lock pushrod connector into the outer hole of the throttle servo arm and test fit it onto the servo. A **pushrod support** is provided and can be glued to the former just in front of the throttle servo. You may need to sand or cut this part to length depending on the pushrod position. When satisfied, slide the support onto the pushrod tube and glue it in place. Tighten the aft end of the throttle pushrod in the screw-lock pushrod connector (do not cut off the excess length of pushrod until you have used your radio system to center the servo and have made your adjustments to the pushrod length).

## Out-runner Motor, Battery & Radio Installation

*If you have installed a glow engine, skip this section as it only contains information relevant to installing a brushless motor.*

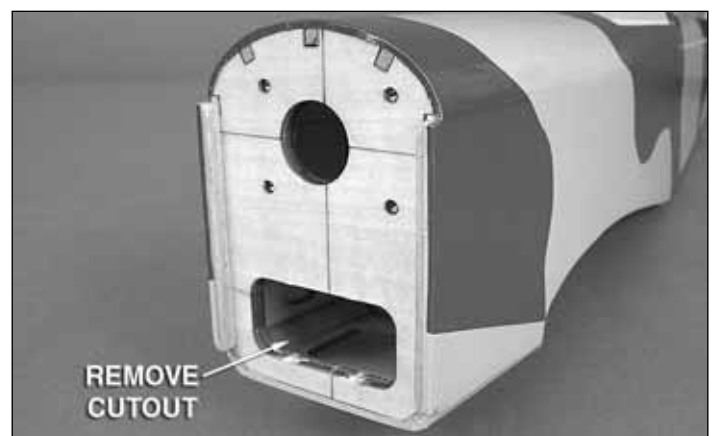

1. Cut the perforations along the cooling hole and remove the cutout.



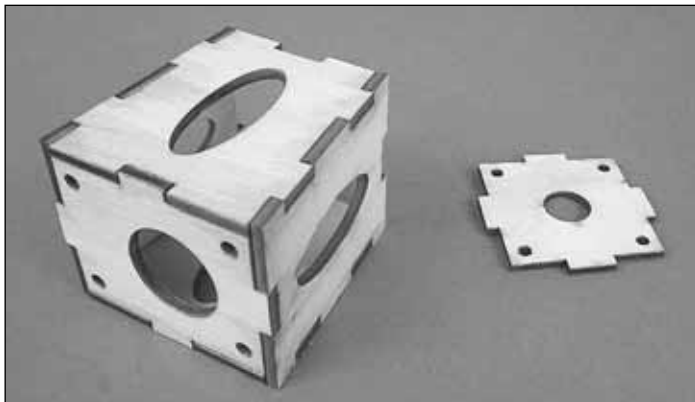
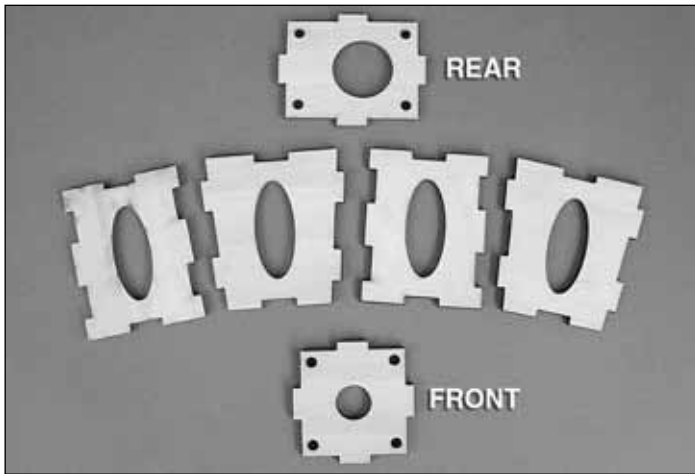

2. Locate the six brushless **motor mount adapter pieces**. Glue the back piece and the four side pieces together as shown. The tabs on the pieces will all interlock together.

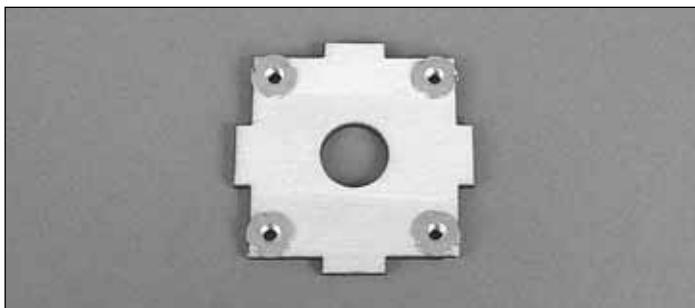

3. Install four 3mm blind nuts into the motor mount adapter front piece. Use a 3mm x 10mm screw and a 3mm flat washer to draw them tight into the holes.

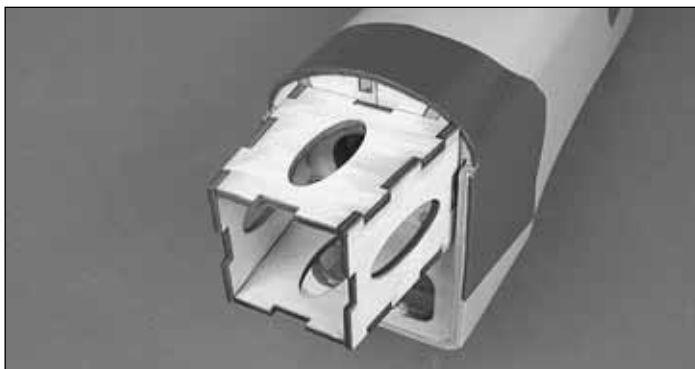

4. Attach the motor mount adapter to the firewall using four 3mm x 16mm machine screws, four 3mm flat washers and thread-locking compound.

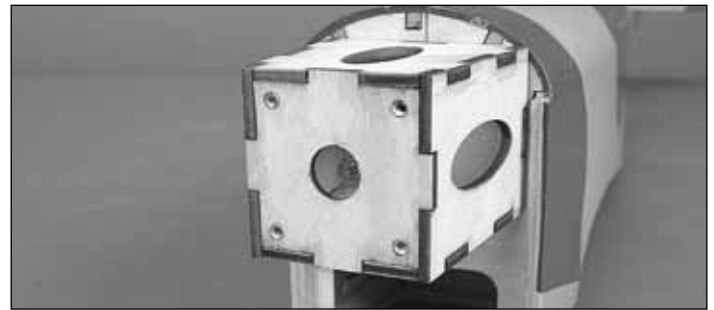

5. Install the brushless motor onto the aluminum motor mount (included with the motor) using four 3mm x 8mm machine screws (included with the motor) and thread-locking compound. If you haven't done so already, install the prop adapter using the hardware included with the motor. Glue the front adapter piece to the brushless motor mount box as shown.

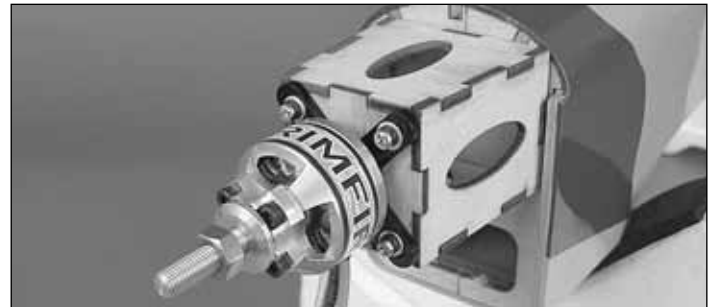

6. Attach the aluminum motor mount to the brushless motor mount box using four 3mm x 10mm machine screws, four 3mm lock washers, four 3mm flat washers and thread-locking compound.

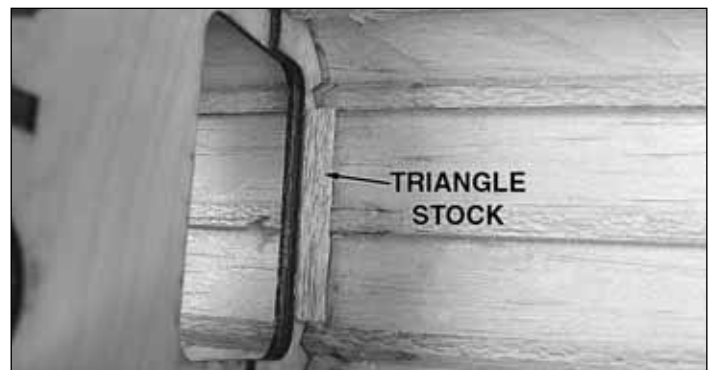

7. Cut a 1-1/2" [38mm] piece from the included 1/4" [6mm] **triangle stock**. Glue the piece flush with the top edge of the fuel tank opening as shown. This will provide a larger mounting surface for the **battery tray**.

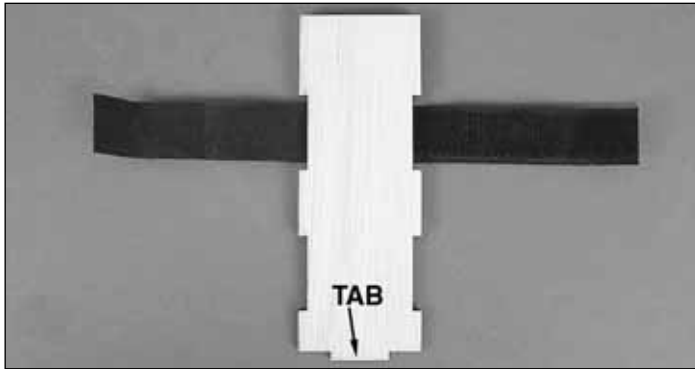
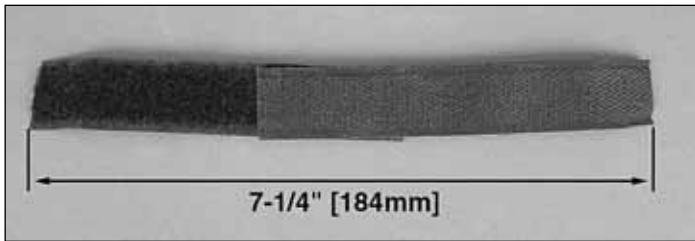

❑ 8. Make a battery strap by cutting the hook and loop material 7-1/4" [184mm] long, overlapping the ends 1-1/2" [38mm]. Glue the strap to the underside of the battery tray with medium or thick CA as shown.



❑ 9. Glue the battery tray into the fuse by keying the tab into the third former and resting the forward end on the fuel tank opening and the triangle stock you glued in step 8. Apply a liberal amount of medium or thick CA glue to the mating surfaces to ensure a very secure battery tray. Cut another piece of triangle stock and glue it against the aft end of the tray and the former.



❑ 10. Glue the **brushless radio tray** to the spars in the location shown.

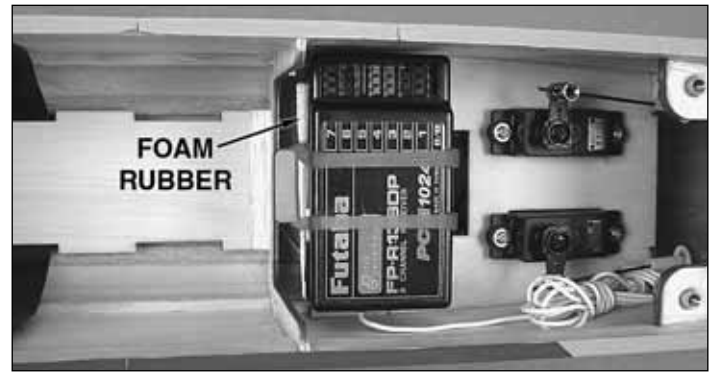

❑ 11. Cut a piece of 1/4" [6mm] or 1/2" [13mm] foam rubber (not included) to fit your receiver. Hook one of the included rubber bands onto the tab on the brushless radio tray and feed the other end above the tray and out of the throttle servo bay. Place your receiver and foam rubber onto the brushless radio tray and loop the rubber band over the receiver and hook it onto the tab.



❑ 12. Trim the covering from the cooling hole cutout on the front underside of the fuse.

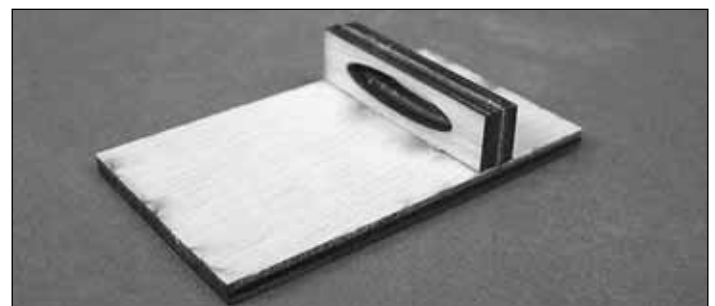

❑ 13. Locate the three **ESC tray pieces**. Glue the small pieces together and then glue them into the slot in the large piece.



14. Apply a coating of epoxy to the flat side of the ESC tray and let it cure undisturbed. The epoxy will provide a smooth surface for the double-sided tape to adhere to. When the epoxy is dry, glue the tray onto the top edge of the cooling hole cutout as shown.

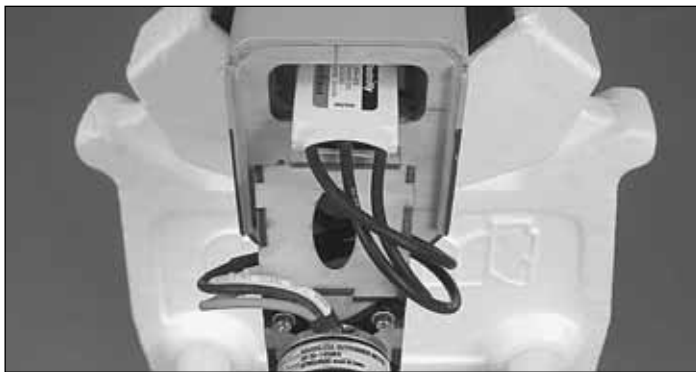

15. Feed the receiver and battery leads on the ESC through the left hole in the second former. Connect the ESC to the receiver and to the motor. If using the recommended ESC and brushless motor, three 4mm male to 3.5mm female bullet connector adapters will be needed. Great Planes offers these adapters for purchase using part number (GPMM3123). Secure the ESC to the ESC tray with a piece of the included double-sided foam servo tape.



### MAKE BATTERY CONNECTOR ADAPTERS

If the Great Planes 4mm male to 3.5mm female bullet connector adapters are not available, or you would like to make your own, the assembly procedure and order numbers for the individual parts are provided below.



A. In order to make three adapters for one complete brushless motor system, you will need Great Planes Gold Plated Bullet Connectors Female 3.5mm (GPMM3113), Great Planes Gold Plated Bullet Connectors Male 4mm (GPMM3114), electrical solder with flux, and a soldering iron.

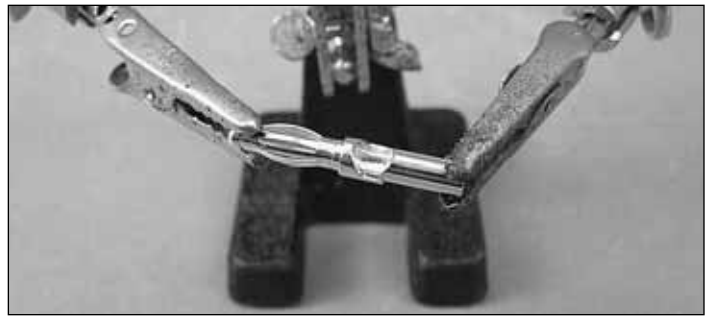

B. Insert the 3.5mm female bullet connector (the end with the cutout on the side) into the open end of the 4mm male bullet connector. Shown in the photo above is the X-Acto® Extra Hands Double Clip (XACR4214). This tool is extremely useful for small soldering tasks.



C. With the female bullet in the open end of the male bullet and the cutouts in both connectors lined up, apply solder with flux into the cutouts. When applying the solder, it should appear to flow into the joint and around the ends of the connectors until the joint is coated. Excess solder is not necessary as it will simply gather at the bottom of the joint. Use alcohol to wipe the joint clean.



D. When satisfied, slide a piece of heat-shrink tubing over the adapter up to the base of the male bullet connector. Use a heat gun or micro torch to shrink the tubing onto the adapter. If necessary, trim the excess heat-shrink tubing from the end of the female bullet connector.

16. Now is a good time to test the rotation of the motor before the cowl and prop are installed. Use your radio system and battery to temporarily power the motor. If the motor rotates clockwise when viewed from the front, correct the rotation by choosing any two of the three motor leads and reverse their positions.



## FINISH THE MODEL

### Install the Cowl

The cowl installation is shown on the brushless motor power system. Installing the **cowl** over a glow engine is the same. However, in addition to cutting a cooling hole for the engine head, you will also need to make a hole for glow plug access, a hole to access the needle valve, and a cutout for the muffler.

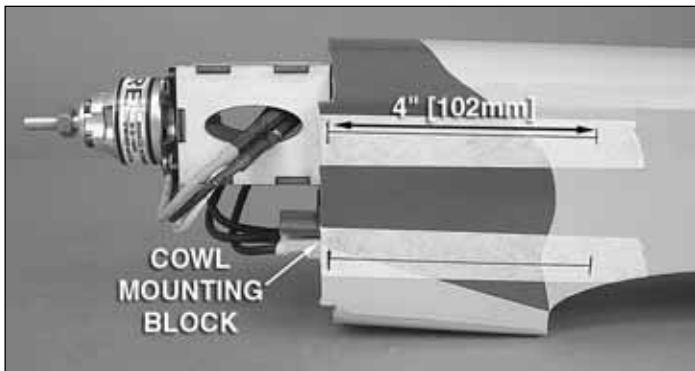

1. Put four pieces of tape at least 5" [127mm] long onto the sides of the fuse (two per side) evenly spaced apart and parallel with the fuse center line. Make a mark on each piece of tape in the center of the **cowl mounting blocks** that are glued to the sides of the firewall. Draw a line using a straightedge 4" [102mm] long from each mark. Mark the end of each line as shown. These lines will be used to drill the mounting holes for the cowl.

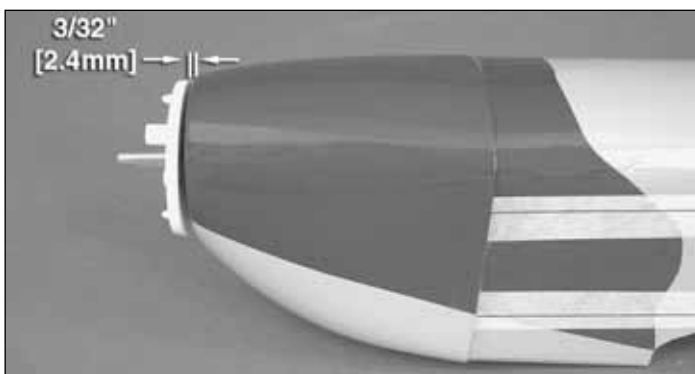

2. Fit the cowl onto the fuse. Temporarily install the spinner backplate onto the motor shaft. The backplate may need to be reamed or drilled out to match the shaft size (1/4" [6.4mm] for the 35-30-1450 out-runner, 1/4" [6.4mm] for the O.S.<sup>®</sup> .25 FX glow engine). Position the cowl so that the front of it is 3/32" [2.4mm] from the backplate, square and is centered behind it. When satisfied, tape the cowl in place.

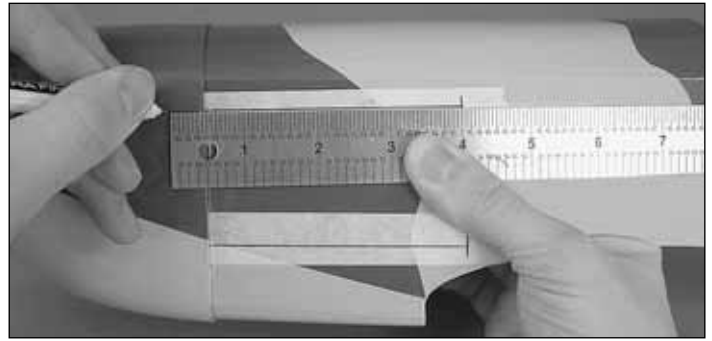

3. Measure forward 4" [102mm] from the aft marks on the tape and mark the cowl for the mounting screw locations. Drill 1/16" [1.6mm] holes through the cowl and through the cowl mounting blocks at each mark.



4. Remove the cowl and tape from the fuse. Cut the necessary holes in the cowl appropriate for your power system. The picture shows a cooling hole for the brushless motor setup. Thread a 2mm x 8mm self-tapping screw into each cowl hole in the fuse and remove it. Apply a couple drops of thin CA into each hole to harden the wood. When the CA has fully cured, install the cowl onto the fuse using four 2mm x 8mm self-tapping screws.

### Final Assembly



1. The receiver antenna can be taped to the underside of the fuse. For a cleaner look, we chose to route the antenna down the inside of the fuse and out the side as shown. To do this, we used a long scrap piece of pushrod tube we had in the shop and inserted it through a small hole drilled beneath the stabilizer. Slide the tube through the hole toward the front of the plane going through the cutouts in the formers. When you reach the receiver with the tube, feed as much of the antenna into the tube as possible, then pull the tube with the antenna inside of it out through the hole.



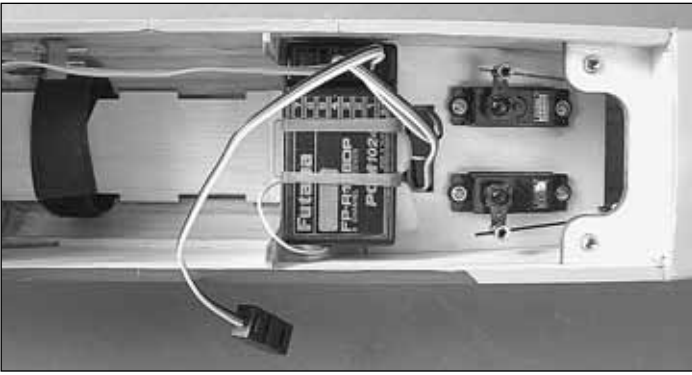

❑ 2. If you have not done so already, connect the elevator and rudder servos to the receiver. If you are using a transmitter that does not support mixing, you will also need a dual servo extension or Y-harness to join the aileron servos together. If you have installed a glow engine, an optional switch and charge jack (not included) can be installed onto the side of the fuselage wherever there is free space. Make sure that it does not interfere with any of the pushrods.

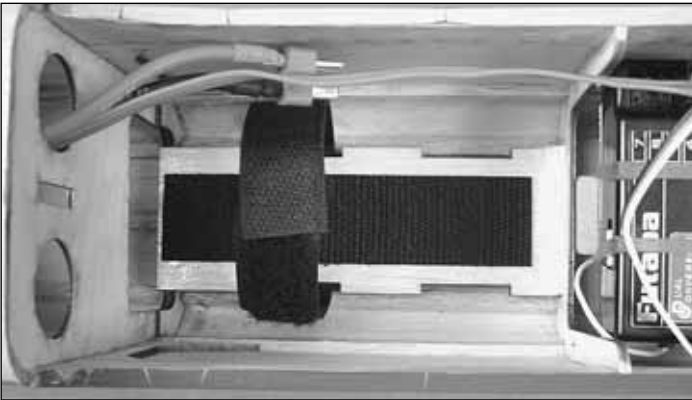

❑ 3. If you have installed a brushless motor, mix up a small batch of epoxy and brush a thin coating onto the battery tray. This will improve the adhesion of the self-adhesive hook and loop material. When the epoxy has cured, apply the hook side of the included self-adhesive hook and loop material to the battery tray (cut to length as needed).

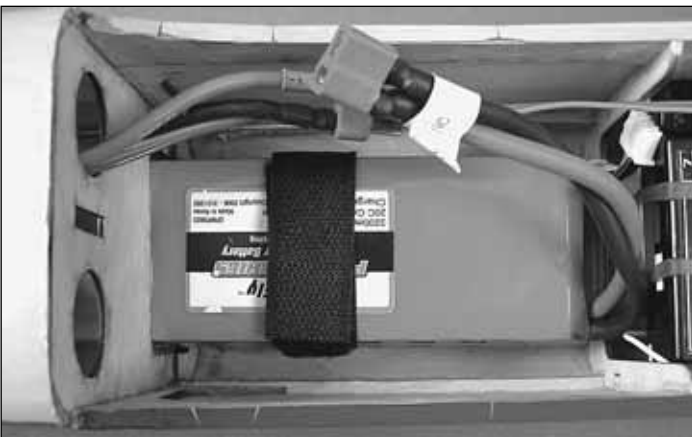

❑ 4. Install the loop side of the included self-adhesive hook and loop material onto the battery pack. Some packs may be able to be moved forward or aft to minimize additional weight added to the plane for balancing purposes. Longer NiMH packs may have little room to move along the battery tray for

balancing purposes. After the plane is completely assembled, experiment with the position of the pack if possible when balancing the plane and mark the optimum position of the pack onto the battery tray for future reference.

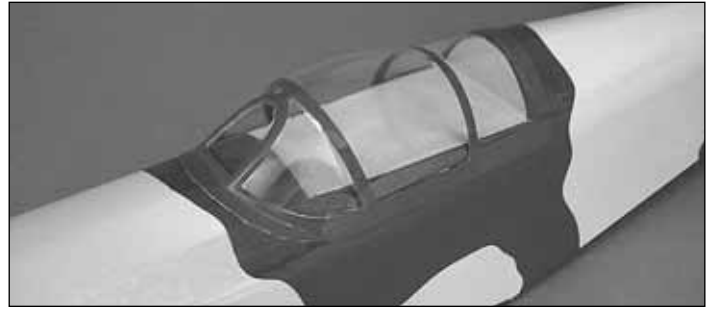

❑ 5. Attach the **canopy** to the fuselage with R/C 56 canopy glue. Use masking tape to hold the canopy in place while the glue dries.

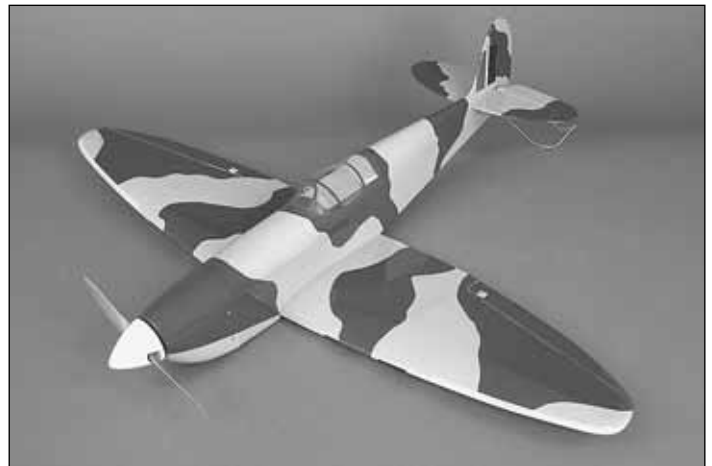

❑ 6. Install your propeller and the included spinner onto the motor shaft. Prepare the model for balancing by installing the wing using two 3mm x 25mm Phillips machine screws and two 3mm flat washers.

## Optional Landing Gear



The Combat Spitfire ARF includes optional **landing gear** for those modelers who choose to sport fly the model and would benefit from using landing gear. The included landing gear is recommended for paved runways only. If you plan to fly the Combat Spitfire ARF in combat competition, we suggest omitting the gear for reduced weight and increased maneuverability.



❑ 1. Locate and remove the covering from the **landing gear slots** on the underside of the wing.

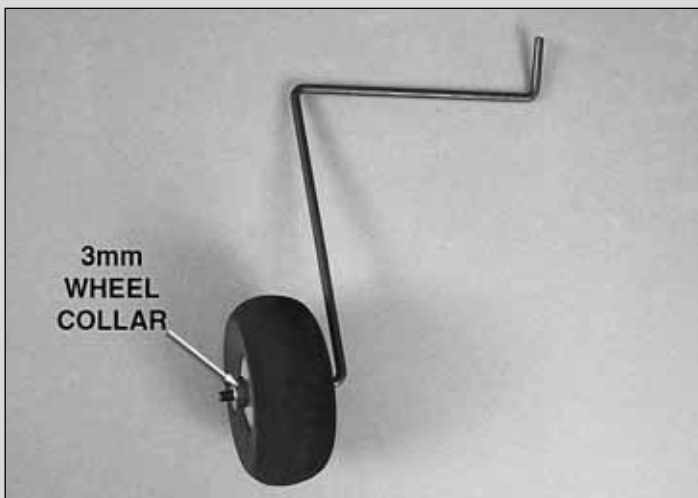

❑ 2. Using four 3mm wheel collars and four 3mm set screws, temporarily install the wheels onto the landing gear centering them on the axles. Tighten the set screws against the axles.

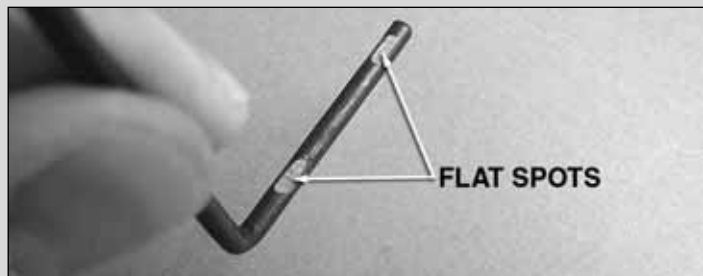

❑ 3. Remove the wheels and wheel collars and grind flat spots on the axles where the set screws made marks from being tightened. A rotary tool such as a Dremel® with a cut-off wheel or a metal file can be used to make the flat spots.

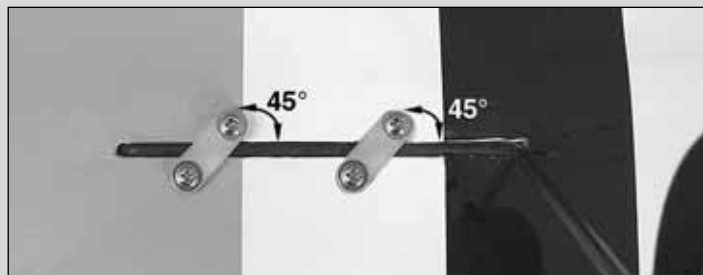

❑ 4. Reinstall the wheels onto the axles using the wheel collars, set screws, and thread-locking compound. Be sure that the wheels rotate freely. Oil the wheels at the axles if necessary. Fit the gear into the slots in the wing. Position four landing gear straps over the wire, evenly spaced and at an approximately 45° angle as shown. Mark the locations for the strap holes onto the wing and drill 5/64" [2mm] holes at the marks (*be sure not to drill completely through the wing!*). Thread a 2.5mm x 10mm self-tapping screw into each hole and remove it. Apply a couple drops of thin CA glue to each hole to harden the wood. Install the straps over the landing gear using eight 2.5mm x 10mm self-tapping screws.

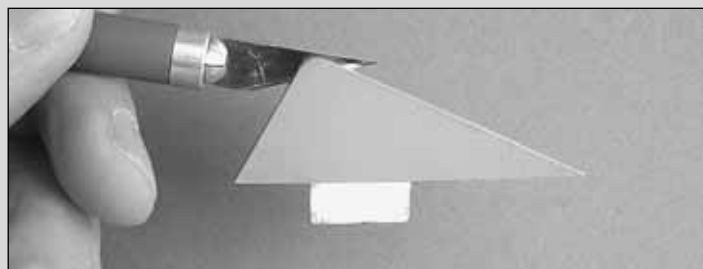

❑ 5. Trim the covering from the slot cut into the **tail skid**. Glue a 3mm washer into the slot so it is flush with the outside edges of the tail skid. The washer will prevent the tail skid from rubbing away when flying from a paved runway.

## GET THE MODEL READY TO FLY

### Check the Control Directions

1. Turn on the transmitter and receiver and center the trims. If necessary, remove the servo arms from the servos and reposition them so they are centered. Reinstall the screws that hold on the servo arms.
2. With the transmitter and receiver still on, check all the control surfaces to see if they are centered. If necessary, adjust the clevises on the pushrods to center the control surfaces.

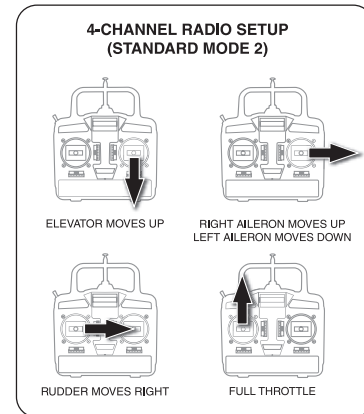

3. Make certain that the control surfaces and the throttle respond in the correct direction as shown in the diagram. If any of the controls respond in the wrong direction, use the servo reversing in the transmitter to reverse the servos connected to those controls. Be certain the control surfaces have remained centered. Adjust if necessary.

### Set the Control Throws

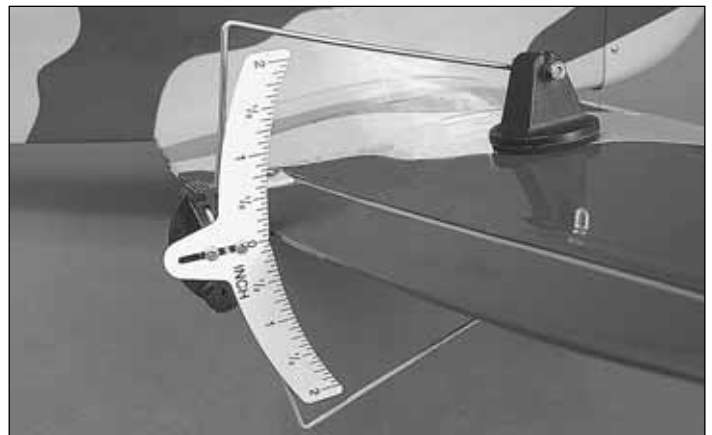

Use a Great Planes AccuThrow (or a ruler) to accurately measure and set the control throw of each control surface as indicated in the chart that follows. If your radio does not have dual rates, we recommend setting the throws at the **low rate** setting.



6. Trim the covering from the long edge of the **tail skid**. Locate the slot for the tail skid tab on the underside of the fuse and remove the covering. Test fit the tail skid into the slot and mark the forward and aft ends of the tail skid on the fuse. Remove the tail skid and cut away the covering between the marks. Glue the tail skid into position using CA glue.

### Apply the Decals

1. Be certain the model is clean and free from oily fingerprints and dust. Prepare a dishpan or small bucket with a mixture of liquid dish soap and warm water—about one teaspoon of soap per gallon of water. Submerge the decal in the soap and water and peel off the paper backing. **Note:** Even though the decals have a “sticky-back” and are not the water transfer type, submersing them in soap & water allows accurate positioning and reduces air bubbles underneath.
2. Position decal on the model where desired. Holding the decal down, use a paper towel to wipe most of the water away.
3. Use a piece of soft balsa or something similar to squeegee remaining water from under the decal. Apply the rest of the decals the same way.

**Note:** The throws are measured at the **widest part** of the elevators, rudder and ailerons.

**These are the recommended control surface throws:**

	<b>High Rate</b>	<b>Low Rate</b>
<b>ELEVATOR:</b>	3/8" [9.5mm] up 3/8" [9.5mm] down	1/4" [6mm] up 1/4" [6mm] down
<b>RUDDER:</b>	3/4" [19mm] right 3/4" [19mm] left	1/2" [13mm] right 1/2" [13mm] left
<b>AILERONS:</b>	3/16" [5mm] up 3/16" [5mm] down	1/8" [3mm] up 1/8" [3mm] down

**IMPORTANT:** The Combat Spitfire ARF has been **extensively** flown and tested to arrive at the throws at which it flies best. Flying your model at these throws will provide you with the greatest chance for successful first flights. If, after you have become accustomed to the way the Combat Spitfire ARF flies, you would like to change the throws to suit your taste, that is fine. However, too much control throw could make the model difficult to control, so remember, "more is not always better."

### ***Balance the Model (C.G.)***

More than any other factor, the **C.G.** (balance point) can have the **greatest** effect on how a model flies, and may determine whether or not your first flight will be successful. If you value this model and wish to enjoy it for many flights, **DO NOT OVERLOOK THIS IMPORTANT PROCEDURE.** A model that is not properly balanced will be unstable and possibly unflyable.

At this stage the model should be in ready-to-fly condition with all of the systems in place including the engine or brushless motor, landing gear, and the radio system (and battery pack if applicable), but with no fuel.

❑ 1. Use a felt-tip pen or 1/8" [3mm]-wide tape to accurately mark the C.G. on the top of the wing on both sides of the fuse. The C.G. is located 2-3/8" [60mm] back from the LE of the wing where it meets the fuselage.

This is where your model should balance for the first flights. Later, you may wish to experiment by shifting the C.G. up to 1/8" [3mm] forward or 1/8" [3mm] back to change the flying characteristics. Moving the C.G. forward may improve the smoothness and stability, but the model may then require more speed for takeoff and make it more difficult to slow for landing. Moving the C.G. aft makes the model more maneuverable, but could also cause it to become too difficult to control. In any case, **start at the recommended balance point** and do not at any time balance the model outside the specified range.

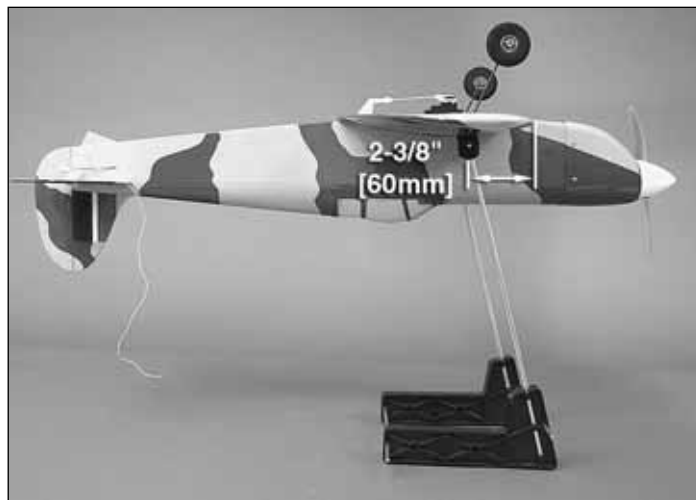

❑ 2. With the wing attached to the fuse, all parts of the model installed (ready to fly) and an empty fuel tank, place the model upside-down on a Great Planes CG Machine, or lift it upside-down at the balance point you marked.

❑ 3. If the tail drops, the model is "tail heavy" and the battery pack and/or receiver must be shifted forward or weight must be added to the nose to balance. If the nose drops, the model is "nose heavy" and the battery pack and/or receiver must be shifted aft or weight must be added to the tail to balance. If possible, relocate the battery pack and receiver to minimize or eliminate any additional ballast required. If additional weight is required, nose weight may be easily added by using a "spinner weight" (GPMQ4645 for the 1 oz. [28g] weight, or GPMQ4646 for the 2 oz. [57g] weight). If spinner weight is not practical or is not enough, use Great Planes (GPMQ4485) "stick-on" lead. A good place to add stick-on nose weight is to the firewall (don't attach weight to the cowl—it is not intended to support weight). Begin by placing incrementally increasing amounts of weight on the bottom of the fuse over the firewall until the model balances. Once you have determined the amount of weight required, it can be permanently attached. If required, tail weight may be added by cutting open the bottom of the fuse and gluing it permanently inside.

**Note:** Do not rely upon the adhesive on the back of the lead weight to permanently hold it in place. Over time, fuel and exhaust residue may soften the adhesive and cause the weight to fall off. Use #2 sheet metal screws, RTV silicone or epoxy to permanently hold the weight in place.

❑ 4. **IMPORTANT:** If you found it necessary to add any weight, recheck the C.G. after the weight has been installed.

## Balance the Model Laterally

1. With the wing level, have an assistant help you lift the model by the engine propeller shaft and the bottom of the fuse under the TE of the fin. Do this several times.
2. If one wing always drops when you lift the model, it means that side is heavy. Balance the airplane by adding weight to the other wing tip. **An airplane that has been laterally balanced will track better in loops and other maneuvers.**

## PREFLIGHT

### Identify Your Model

No matter if you fly at an AMA sanctioned R/C club site or if you fly somewhere on your own, you should always have your name, address, telephone number and AMA number on or inside your model. It is **required** at all AMA R/C club flying sites and AMA sanctioned flying events. Fill out the identification tag on the decal sheet and place it on or inside your model.

### Charge the Batteries

Follow the battery charging instructions that came with your radio control system to charge the batteries. You should always charge your transmitter and receiver batteries the night before you go flying, and at other times as recommended by the radio manufacturer.

**CAUTION:** Unless the instructions that came with your radio system state differently, the **initial** charge on **new** transmitter and receiver batteries should be done for 15 hours using the slow-charger that came with the radio system. This will “condition” the batteries so that the next charge may be done using the fast-charger of your choice. If the initial charge is done with a fast-charger the batteries may not reach their full capacity and you may be flying with batteries that are only partially charged.

## Balance the Propellers

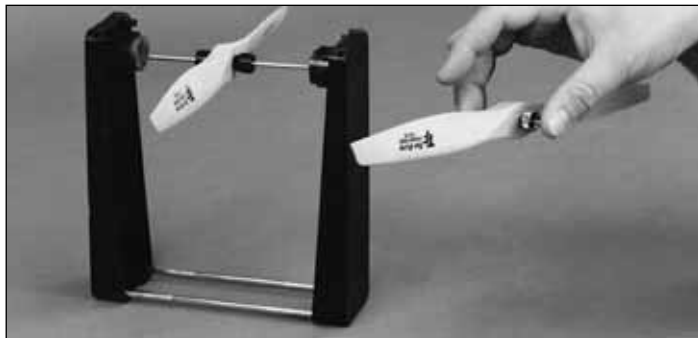

Carefully balance your propeller and spare propellers before you fly. An unbalanced prop can be the single most significant cause of vibration that can damage your model. Not only will engine mounting screws and bolts loosen, possibly with disastrous effect, but vibration may also damage your radio receiver and battery. Vibration can also cause your fuel to foam, which will, in turn, cause your engine to run hot or quit.

We use a Top Flite Precision Magnetic Prop Balancer (TOPQ5700) in the workshop and keep a Great Planes Fingertip Prop Balancer (GPMQ5000) in our flight box.

### Ground Check

**If the engine is new, follow the engine manufacturer's instructions to break-in the engine.** After break-in, confirm that the engine idles reliably, transitions smoothly and rapidly to full power and maintains full power—indefinitely. After you run the engine on the model, inspect the model closely to make sure all screws remained tight, the hinges are secure, the prop is secure and all pushrods and connectors are secure.

### Range Check

Ground check the operational range of your radio before the first flight of the day. With the transmitter antenna collapsed and the receiver and transmitter on, you should be able to walk at least 100 feet away from the model and still have control. Have an assistant stand by your model and, while you work the controls, tell you what the control surfaces are doing. Repeat this test **with the engine running** at various speeds with an assistant holding the model, using hand signals to show you what is happening. If the control surfaces do not respond correctly, **do not fly!** Find and correct the problem first. Look for loose servo connections or broken wires, corroded wires on old servo connectors, poor solder joints in your battery pack or a defective cell, or a damaged receiver crystal from a previous crash.



## ENGINE / MOTOR SAFETY PRECAUTIONS

**Failure to follow these safety precautions may result in severe injury to yourself and others.**

Keep all engine fuel in a safe place, away from high heat, sparks or flames, as fuel is very flammable. Do not smoke near the engine or fuel; and remember that engine exhaust gives off a great deal of deadly carbon monoxide. Therefore, **do not run the engine in a closed room or garage.**

Get help from an experienced pilot when learning to operate engines.

Use safety glasses when starting or running engines.

Do not run the engine in an area of loose gravel or sand; the propeller may throw such material in your face or eyes.

Keep your face and body as well as all spectators away from the plane of rotation of the propeller as you start and run the engine.

Keep these items away from the prop: loose clothing, shirt sleeves, ties, scarves, long hair or loose objects such as pencils or screwdrivers that may fall out of shirt or jacket pockets into the prop.

Use a "chicken stick" or electric starter to start the engine. Do not use your fingers to flip the propeller. Make certain the glow plug clip or connector is secure so that it will not pop off or otherwise get into the running propeller.

Make all engine adjustments from behind the rotating propeller.

The engine gets hot! Do not touch it during or right after operation. Make sure fuel lines are in good condition so fuel will not leak onto a hot engine, causing a fire.

To stop a glow engine, cut off the fuel supply by closing off the fuel line or following the engine manufacturer's recommendations. Do not use hands, fingers or any other body part to try to stop the engine. Do not throw anything into the propeller of a running engine.

## LITHIUM BATTERY HANDLING & USAGE

**WARNING!!** Read the entire instruction sheet included with your battery. Failure to follow all instructions could cause permanent damage to the battery and its surroundings, and cause bodily harm!

- ONLY use a LiPo approved charger. NEVER use a NiCd/NiMH peak charger!
- NEVER charge in excess of 4.20V per cell.
- ONLY charge through the "charge" lead. NEVER charge through the "discharge" lead.
- NEVER charge at currents greater than 1C.
- ALWAYS set charger's output volts to match battery volts.
- ALWAYS charge in a fireproof location.
- NEVER trickle charge.
- NEVER allow the battery temperature to exceed 150° F [65° C].
- NEVER disassemble or modify pack wiring in any way or puncture cells.
- NEVER discharge below 2.5V per cell.
- NEVER place on combustible materials or leave unattended during charge or discharge.
- ALWAYS KEEP OUT OF REACH OF CHILDREN.

## AMA SAFETY CODE (excerpts)

Read and abide by the following excerpts from the Academy of Model Aeronautics Safety Code. For the complete Safety Code refer to *Model Aviation* magazine, the AMA web site or the Code that came with your AMA license.

### General

- 1) I will not fly my model aircraft in sanctioned events, air shows, or model flying demonstrations until it has been proven to be airworthy by having been previously, successfully flight tested.
- 2) I will not fly my model aircraft higher than approximately 400 feet within 3 miles of an airport without notifying the airport operator. I will give right-of-way and avoid flying in the proximity of full-scale aircraft. Where necessary, an observer shall be utilized to supervise flying to avoid having models fly in the proximity of full-scale aircraft.
- 3) Where established, I will abide by the safety rules for the flying site I use, and I will not willfully and deliberately fly my models in a careless, reckless and/or dangerous manner.
- 5) I will not fly my model unless it is identified with my name and address or AMA number, on or in the model. **Note:** This does not apply to models while being flown indoors.
- 7) I will not operate models with pyrotechnics (any device that explodes, burns, or propels a projectile of any kind).

## Radio Control

- 1) I will have completed a successful radio equipment ground check before the first flight of a new or repaired model.
- 2) I will not fly my model aircraft in the presence of spectators until I become a qualified flier, unless assisted by an experienced helper.
- 3) At all flying sites a straight or curved line(s) must be established in front of which all flying takes place with the other side for spectators. Only personnel involved with flying the aircraft are allowed at or in the front of the flight line. Intentional flying behind the flight line is prohibited.
- 4) I will operate my model using only radio control frequencies currently allowed by the Federal Communications Commission.
- 5) **I will not knowingly operate my model within three miles of any pre-existing flying site except in accordance with the frequency sharing agreement listed** (in the complete AMA Safety Code).
- 9) Under no circumstances may a pilot or other person touch a powered model in flight; **nor should any part of the model other than the landing gear, intentionally touch the ground, except while landing.**

## CHECK LIST

During the last few moments of preparation your mind may be elsewhere anticipating the excitement of the first flight. Because of this, you may be more likely to overlook certain checks and procedures that should be performed before the model is flown. To help avoid this, a check list is provided to make sure these important areas are not overlooked. Many are covered in the instruction manual, so where appropriate, refer to the manual for complete instructions. Be sure to check the items off as they are completed.

1. Check the C.G. according to the measurements provided in the manual.
2. Be certain the battery and receiver are securely mounted in the fuse. Simply stuffing them into place with foam rubber is not sufficient.
3. Extend your receiver antenna.
4. Balance your model *laterally* as explained in the instructions.
5. Use thread-locking compound to secure critical fasteners such as the set screws that hold the wheel axles to the struts, screws that hold the carburetor arm (if applicable), screw-lock pushrod connectors, etc.
6. Add a drop of oil to the axles so the wheels will turn freely.
7. Make sure all hinges are **securely** glued in place.
8. Reinforce holes for wood screws with thin CA where appropriate (servo mounting screws, cowl mounting screws, etc.).

9. Confirm that all controls operate in the correct direction and the throws are set up according to the manual.
10. Make sure there are silicone retainers on all the clevises and that all servo arms are secured to the servos with the screws included with your radio.
11. Secure connections between servo wires and Y-connectors or servo extensions, and the connection between your battery pack and the on/off switch with vinyl tape, heat-shrink tubing or special clips suitable for that purpose.
12. Make sure any servo extension cords you may have used do not interfere with other systems (servo arms, pushrods, etc.).
13. Secure the pressure tap (if used) to the muffler with high temp RTV silicone, thread-locking compound or J.B. Weld.
14. Make sure the fuel lines are connected and are not kinked.
15. Balance your propeller (and spare propellers).
16. Tighten the propeller nut and spinner.
17. Place your name, address, AMA number and telephone number on or inside your model.
18. Cycle your receiver battery pack (if necessary) and make sure it is fully charged.
19. If you wish to photograph your model, do so before your first flight.
20. Range check your radio when you get to the flying field.

## FLYING

The Combat Spitfire ARF is a great-flying model that flies smoothly and predictably. The Combat Spitfire ARF does not, however, possess the self-recovery characteristics of a primary R/C trainer and should be flown only by experienced R/C pilots.

## Fuel Mixture Adjustments

A fully cowled engine may run at a higher temperature than an un-cowled engine. For this reason, the fuel mixture should be richened so the engine runs at about 200 rpm below peak speed. By running the engine slightly rich, you will help prevent dead-stick landings caused by overheating.



**CAUTION (THIS APPLIES TO ALL R/C AIRPLANES):** If, while flying, you notice an alarming or unusual sound such as a low-pitched “buzz,” this may indicate control surface *flutter*. Flutter occurs when a control surface (such as an aileron or elevator) or a flying surface (such as a wing or stab) rapidly vibrates up and down (thus causing the noise). In extreme cases, if not detected immediately, flutter can actually cause the control surface to detach or the flying surface to fail, thus causing loss of control followed by an impending crash. The best thing to do when flutter is detected is to slow the model **immediately** by reducing power, then land as soon as safely possible. Identify which surface fluttered (so the problem may be resolved) by checking all the servo grommets for deterioration or signs of vibration. Make certain all pushrod linkages are secure and free of play. If it fluttered once, under similar circumstances it will probably flutter again unless the problem is fixed. Some things which can cause flutter are; Excessive hinge gap; Not mounting control horns solidly; Poor fit of clevis pin in horn; Side-play of wire pushrods caused by large bends; Excessive free play in servo gears; Insecure servo mounting; and one of the most prevalent causes of flutter; Flying an over-powered model at excessive speeds.

## Takeoff

Before you get ready to takeoff, see how the model handles on the ground by doing a few practice runs at **low speeds** on the runway. Hold “up” elevator to keep the tail skid on the ground. If you need to calm your nerves before the maiden flight, shut the engine down and bring the model back into the pits. Top off the fuel, then check all fasteners and control linkages for peace of mind.

Remember to takeoff into the wind. When you're ready, point the model straight down the runway, hold a bit of up elevator to keep the tail on the ground, then gradually advance the throttle. As the model gains speed decrease up elevator allowing the tail to come off the ground. One of the most important things to remember with a taildragger is to always be ready to apply **right** rudder to counteract engine torque. Gain as much speed as your runway and flying site will practically allow before gently applying up elevator, lifting the model into the air. At this moment it is likely that you will need to apply more right rudder to counteract engine torque. Be smooth on the elevator stick, allowing the model to establish a **gentle** climb to a safe altitude before turning into the traffic pattern.

## Flight

For reassurance and to keep an eye on other traffic, it is a good idea to have an assistant on the flight line with you. Tell him to remind you to throttle back once the plane gets to a comfortable altitude. While full throttle is usually desirable for takeoff, most models fly more smoothly at reduced speeds.

Take it easy with the Combat Spitfire ARF for the first few flights, gradually getting acquainted with it as you gain confidence. Adjust the trims to maintain straight and level flight. After flying around for a while, and while still at a safe altitude with plenty of fuel, practice slow flight and execute practice landing approaches by reducing the throttle to see how the model handles at slower speeds. Add power to see how she climbs as well. Continue to fly around, executing various maneuvers and making mental notes (or having your assistant write them down) of what trim or C.G. changes may be required to fine tune the model so it flies the way you like. Mind your flight time, but use this first flight to become familiar with your model before landing.

## Landing

To initiate a landing approach, lower the throttle while on the downwind leg. Allow the nose of the model to pitch downward to gradually bleed off altitude. Continue to lose altitude, but maintain airspeed by keeping the nose down as you turn onto the crosswind leg. Make your final turn toward the runway (into the wind) keeping the nose down to maintain airspeed and control. Level the attitude when the model reaches the runway threshold, modulating the throttle as necessary to maintain your glide path and airspeed. If you are going to overshoot, smoothly advance the throttle (always ready on the right rudder to counteract torque) and climb out to make another attempt. When you're ready to make your landing flare and the model is a foot or so off the deck, smoothly increase up elevator until it gently touches down. Once the model is on the runway and has lost flying speed, hold up elevator to place the tail on the ground.

One final note about flying your model. Have a goal or flight plan in mind for **every** flight. This can be learning a new maneuver(s), improving a maneuver(s) you already know, or learning how the model behaves in certain conditions (such as on high or low rates). This is not necessarily to improve your skills (*though it is never a bad idea!*), but more importantly so you do not surprise yourself by impulsively attempting a maneuver and suddenly finding that you've run out of time, altitude or airspeed. Every maneuver should be deliberate, not impulsive. For example, if you're going to do a loop, check your altitude, mind the wind direction (anticipating rudder corrections that will be required to maintain heading), remember to throttle back at the top, and make certain you are on the desired rates (high/low rates). A flight plan greatly reduces the chances of crashing your model just because of poor planning and impulsive moves. **Remember to think.**

***Have a ball! But always stay in control and fly in a safe manner.***

**GOOD LUCK AND GREAT FLYING!**

## OTHER ITEMS AVAILABLE FROM GREAT PLANES



### Great Planes 1/12 Scale Combat ARFs.

R/C combat flying requires a special breed of pilot...and a special type of aircraft. Great Planes' 1/12 scale fighters meet the criteria perfectly: quick and easy to assemble, very affordable, and AMA legal. In just 7 to 10 hours you can have these swift, nimble fliers ready for exciting dogfighting action. Structures feature prebuilt balsa/ply construction, factory-covered with high-quality, iron-on film, and come with a fiberglass cowl, clear canopy, decals and top-notch hardware. Plus, they're compact enough to carry with you for spur-of-the-moment fun! Dual aileron servos boost control authority and speed – important for the precise maneuverability needed to become a combat "ace," and a bonus if you're just enjoying some warbird-styled sport fun. Choose the 43.3" span **Corsair (GPMA1470)** or 38.5" span **P-51 Mustang (GPMA1475)** – or get them both!



### Great Planes ElectriFly™ 35-30-1450 RimFire™ Out-runner Brushless Motor

- Highly efficient and virtually maintenance-free. Bearings are double-shielded and permanently lubricated.
- Installed, gold-plated bullet connectors compatible with all ElectriFly ESCs.

- Ideal for brushed-to-brushless upgrades and glow-to-electric conversions!
- Prop adapter, motor mount and hardware included.

Powered by rare-earth Neodymium magnets, RimFire out-runner motors produce explosive acceleration in planes ranging from park flyers to 1.60-size giants! Their high-torque design eliminates the need for a gearbox, making them the simpler, lighter and less expensive alternative to a brushed motor and gearbox. Plus, their innovative housing optimizes cooling, allowing RimFire motors to produce 50% more performance power than out-runners of similar size. **GPMG4600**



### O.S.® .25 FX Engine

The economical .25 FX engine has dual ball bearings for durability and smooth operation, plus a low crankcase profile that allows for a proportionately taller, semi-squared head to increase cooling fin area. The needle valve is remotely mounted for pilot safety, and an O-ring and ratchet spring minimizes "creep" due to air leaks and vibration. Muffler is included; glow plug required. **OSMG0525**



### ElectriFly by Great Planes 3200mAh Power Series LiPo Battery with Balance Connector

Ideal for scale aircraft, bigger sport aerobats, 3D planes, and larger electric models, the Power Series 3200mAh LiPo pack enables you to enjoy the benefits of balancing. The cells are conditioned to last longer, and can be fully charged to 4.20V, ensuring maximum power from the pack. A LiPo Cell Balancer (like ElectriFly's Equinox LiPo Balancer GPMM3160) or a Balancing Charger is required. **GPMP0623**

