

25% YAK 54 3D ARF

1.60 GLOW / 43 cc GAS **PERFORMANCE SERIES™**

INSTRUCTION MANUAL



Wingspan: 81 in [2055 mm]
Wing Area: 1138 sq in [73.4 dm²]
Weight: 12.5 – 15.25 lb [5670 – 6860 g]
Wing Loading: 25 – 30 oz/sq ft [77 – 93 g/dm²]
Length: 68 in [1727 mm]
Radio: 4–6 channel, 7 servos minimum
Engine: 1.5 – 1.8 cu in [25 – 30 cc] two-stroke glow engine,
1.8 – 2.1 cu in [30 – 36 cc] four-stroke glow engine,
1.9 – 2.6 cu in [32 – 43 cc] gasoline engine

WARRANTY

Great Planes® Model Manufacturing Co. guarantees this kit to be free from defects in both material and workmanship at the date of purchase. This warranty does not cover any component parts damaged by use or modification. **In no case shall Great Planes' liability exceed the original cost of the purchased kit.** Further, Great Planes reserves the right to change or modify this warranty without notice.

In that Great Planes has no control over the final assembly or material used for final assembly, no liability shall be assumed nor accepted for any damage resulting from the use by the user of the final user-assembled product. By the act of using the user-assembled product, the user accepts all resulting liability.

If the buyer is not prepared to accept the liability associated with the use of this product, the buyer is advised to return this kit immediately in new and unused condition to the place of purchase.

To make a warranty claim send the defective part or item to **Hobby Services** at the address below:

Hobby Services
3002 N. Apollo Dr., Suite 1
Champaign, IL 61822
USA

Include a letter stating your name, return shipping address, as much contact information as possible (daytime telephone number, fax number, e-mail address), a detailed description of the problem and a photocopy of the purchase receipt. Upon receipt of the package the problem will be evaluated as quickly as possible.

READ THROUGH THIS MANUAL BEFORE STARTING CONSTRUCTION. IT CONTAINS IMPORTANT INSTRUCTIONS AND WARNINGS CONCERNING THE ASSEMBLY AND USE OF THIS MODEL.



Champaign, Illinois
(217) 398-8970, Ext 5
airsupport@greatplanes.com

TABLE OF CONTENTS

INTRODUCTION	2
AMA	2
IMAA	3
SAFETY PRECAUTIONS	3
DECISIONS YOU MUST MAKE	3
Fuel Tank Setup	3
Building Stand	4
Radio Equipment	4
Engine Recommendations	4
ADDITIONAL ITEMS REQUIRED	4
Adhesives & Building Supplies	4
Optional Supplies & Tools	4
IMPORTANT BUILDING NOTES	5
ORDERING REPLACEMENT PARTS	5
COMMON ABBREVIATIONS	6
METRIC CONVERSIONS	6
METRIC/INCH RULER	6
KIT INSPECTION	7
KIT CONTENTS	7
PREPARATIONS	8
ASSEMBLE THE WING	8
Install the Ailerons	8
Install the Aileron Servos & Pushrods	9
Finish the Wing	10
ASSEMBLE THE FUSELAGE	11
Install the Rudder & Tail Gear	11
Assemble & Install the Main Gear	12
Install the Elevators & Stabilizer	13
Install the Elevator Servos & Linkage	15
Install the Rudder Servos & Linkage (Recommended Glow Engine Installation)	16
Install the Rudder Servos & Linkage (Recommended Gas Engine Installation)	18
INSTALL THE ENGINE & FUEL TANK	19
Glow Engine Installation	19
Install the Throttle Servo (Glow Engine)	19
Install the Fuel Tank (Glow Engine)	20
Optional Gas Engine Installation	21
Install the Throttle Servo (Gas Engine)	23
Prepare the Cowl	23
FINISH THE MODEL	25
Install the Radio System	25
Install the Cowl	26
Install the Spinner	27
Attach the Wing & Canopy	27
Apply the Decals	28
GET THE MODEL READY TO FLY	28
Check the Control Directions	28
Set the Control Throws	29
Balance the Model (C.G.)	29
Balance the Model Laterally	30
PREFLIGHT	30
Identify Your Model	30
Charge the Batteries	30
Balance the Propellers	30
Ground Check	30
Range Check	30
ENGINE SAFETY PRECAUTIONS	31
AMA SAFETY CODE (excerpts)	31
IMAA SAFETY CODE (excerpts)	32
CHECK LIST	33
FLYING	34
Fuel Mixture Adjustments	34
Takeoff	34
Flight	34
Landing	34
ENGINE MOUNTING TEMPLATES	Back Cover Page

INTRODUCTION

The Yak 54 1.60 ARF is a great 3D model mixed with a blend of precision aerobatics. The Yak is fully capable of doing any 3D maneuver that exists or that you can dream of. The Yak is also capable of doing "IMAC" style aerobatics and would be fully acceptable for flying in the "Unlimited" class. The Yak 54 1.60 ARF is the perfect airplane for the modeler that wants to improve his or her 3D skills or wants to start flying IMAC with a low cost budget in mind.

The Yak 54 1.60 ARF is capable of doing blenders, torque rolls, harriers inverted and upright, harrier rolls, waterfalls, walls, parachutes and anything else you can dream up. It is also designed to fly exceptionally precise for doing IMAC aerobatics.

For the latest technical updates or manual corrections to the Yak 54 1.60 ARF, visit the Great Planes web site at www.greatplanes.com. Open the "Airplanes" link, then select the Yak 54 1.60 ARF. If there is new technical information or changes to this model a "tech notice" box will appear in the upper left corner of the page.

AMA

We urge you to join the **AMA** (Academy of Model Aeronautics) and a local R/C club. The AMA is the governing body of model aviation and membership is required to fly at AMA clubs. Though joining the AMA provides many benefits, one of the primary reasons to join is liability protection. Coverage is not limited to flying at contests or on the club field. It even applies to flying at public demonstrations and air shows. Failure to comply with the Safety Code (excerpts printed in the back of the manual) may endanger insurance coverage. Additionally, training programs and instructors are available at AMA club sites to help you get started the right way. There are over 2,500 AMA chartered clubs across the country. Contact the AMA at the address or toll-free phone number below.



Academy of Model Aeronautics
5151 East Memorial Drive
Muncie, IN 47302
Tele: (800) 435-9262
Fax (765) 741-0057
Or via the Internet at:
<http://www.modelaircraft.org>

IMPORTANT!!! Two of the most important things you can do to preserve the radio controlled aircraft hobby are to avoid flying near full-scale aircraft and avoid flying near or over groups of people.

IMAA

The Great Planes Yak 54 1.60 ARF is an excellent sport-scale model and is eligible to fly in IMAA events. The **IMAA** (International Miniature Aircraft Association) is an organization that promotes non-competitive flying of giant-scale models. If you plan to attend an IMAA event, obtain a copy of the **IMAA Safety Code** by contacting the IMAA at the address or telephone number below.

IMAA
205 S. Hilldale Road
Salina, KS 67401
(913) 823-5569
www.fly-ima.org/ima/sanction.html

PROTECT YOUR MODEL, YOURSELF & OTHERS...FOLLOW THESE IMPORTANT SAFETY PRECAUTIONS

1. Your Yak 54 1.60 ARF should not be considered a toy, but rather a sophisticated, working model that functions very much like a full-size airplane. Because of its performance capabilities, the Yak 54 1.60 ARF, if not assembled and operated correctly, could possibly cause injury to yourself or spectators and damage to property.

2. You must assemble the model **according to the instructions**. Do not alter or modify the model, as doing so may result in an unsafe or unflyable model. In a few cases the instructions may differ slightly from the photos. In those instances the written instructions should be considered as correct.

3. You must take time to **build straight, true and strong**.

4. You must use an R/C radio system that is in first-class condition, and a correctly sized engine and components (fuel tank, wheels, etc.) throughout the building process.

5. You must correctly install all R/C and other components so that the model operates correctly on the ground and in the air.

6. You must check the operation of the model before **every** flight to insure that all equipment is operating and that the model has remained structurally sound. Be sure to check clevises or other connectors often and replace them if they show any signs of wear or fatigue.

7. If you are not an experienced pilot or have not flown this type of model before, we recommend that you get the assistance of an experienced pilot in your R/C club for your first flights. If you're not a member of a club, your local hobby shop has information about clubs in your area whose membership includes experienced pilots.

8. While this kit has been flight tested to exceed normal use, if the plane will be used for extremely high-stress flying, such as racing, or if an engine larger than one in the recommended range is used, the modeler is responsible for taking steps to reinforce the high-stress points and/or substituting hardware more suitable for the increased stress.

9. **WARNING:** The cowl and wheel spats included in this kit are made of fiberglass, the fibers of which may cause eye, skin and respiratory tract irritation. Never blow into a part (cowl) to remove fiberglass dust, as the dust will blow back into your eyes. Always wear safety goggles, a particle mask and rubber gloves when grinding, drilling and sanding fiberglass parts. Vacuum the parts and the work area thoroughly after working with fiberglass parts.

We, as the kit manufacturer, provide you with a top quality, thoroughly tested kit and instructions, but ultimately the quality and flyability of your finished model depends on how you build it; therefore, we cannot in any way guarantee the performance of your completed model, and no representations are expressed or implied as to the performance or safety of your completed model.

Remember: Take your time and follow the instructions to end up with a well-built model that is straight and true.

DECISIONS YOU MUST MAKE

This is a partial list of items required to finish the Yak 54 1.60 ARF that may require planning or decision-making before starting to build. Order numbers are provided in parentheses.

Fuel Tank Setup

The fuel tank included with this kit is suitable for use with glow fuel. However, if using a gas engine, the fuel tank must be converted to work with gasoline. This can be done by purchasing a Sullivan #484 Gasoline/Diesel fuel tank conversion kit (SULQ2684), a package of Du-Bro #813 1/8" [3.2 mm] I.D. fuel line barbs (DUBQ0670) and 3' of Great Planes gasoline fuel tubing (GPMQ4135). Without the fuel line barbs, some types of gas-compatible fuel line may slip off the metal fuel tubes. If the Sullivan conversion kit is not available, the Du-Bro #400 gas conversion stopper (DUBQ0675) and one 12" [300 mm] piece of K+S 1/8" [3.2 mm] soft brass tubing (K+SR5128—box of 5) could also be used to make the conversion.

Building Stand



A building stand or cradle comes in handy during the build. We use the Robart Super Stand II (ROBP1402) for all our projects in R&D, and it can be seen in pictures throughout this manual.

Radio Equipment

Since the Yak 54 1.60 ARF is a large model capable of extreme aerobatics, standard servos should not be used to operate the control surfaces. Servos with a minimum torque rating of 98 oz-in [7.1 kg-cm] are required except for the throttle servo, which may be operated by a standard servo.

The following servo extensions and Y-harnesses were also used to build the Yak 54 1.60 ARF as shown in the manual.

- (2) 36" [910mm] servo extensions for elevator servos (HCAM2726 for Futaba J-connector)
- (2) 36" [910mm] servo extension for tail mounted rudder servos (HCAM2726 for Futaba J-connector)
- (2) 24" [610mm] servo extensions for aileron servos (HCAM2721 for Futaba J-connector)
- (2) 6" [150mm] servo extensions for forward mounted rudder servos (HCAM2701 for Futaba J-connector)
- (1) 12" [305mm] servo extension for throttle servo (HCAM2711 for Futaba J-connector)

Optional: (If using a radio system that does not support mixing of the elevator, rudder, and aileron servos, Y-harnesses will be required)

- (2) Hobbico® Pro HD Y-Harness (HCAM2751 for Futaba J-connector)
- (1) Reversing Y-Harness (for elevator servos)
- A battery pack with a **minimum** of 1500mAh should also be used. When flying large models such as this, ALWAYS check the battery condition before each flight.

Engine Recommendations

The recommended engine size range for the Yak 54 1.60 ARF is 1.5 to 1.8 cu in [25–30 cc] two-stroke glow engine, 1.8 to 2.1 cu in [30–36 cc] four-stroke glow engine, or 1.9 to 2.6 cu in [32–43 cc] gasoline engine. We recommend either

the O.S.® 1.60 FX glow engine (OSMG0661) or the Fuji-Imvac™ BT-43 EI™ gasoline engine (FJIG0143). Both of these engines will allow the Yak 54 1.60 ARF to perform the 3D maneuvers it was designed for and the installations of both engines are covered in this manual. **Do not install an engine larger than recommended!**

ADDITIONAL ITEMS REQUIRED

Adhesives & Building Supplies

This is the list of Adhesives and Building Supplies that are required to finish the Yak 54.

- Pro™ 30-minute epoxy (GPMR6047)
- Pro 6-minute epoxy (GPMR6045)
- 1/2 oz. [15 g] Thin Pro CA (GPMR6001)
- 1/2 oz. [15 g] Medium Pro CA+ (GPMR6007)
- Hobbico 60 watt soldering iron (HCAR0776)
- Hobby Heat™ Micro Torch II (HCAR0755)
- Silver solder w/flux (GPMR8070)
- Petroleum jelly (Vaseline®)
- 3' [900 mm] Standard silicone fuel tubing (GPMQ4131)
- R/C foam rubber (1/4" [6 mm] – HCAQ1000)
- Microballoons (TOPR1090)
- Drill bits: 1/16" [1.6 mm], 3/32" [2.4 mm], 7/64" [2.8 mm], 9/64" [3.6 mm], 5/32" [4 mm]
- Denatured alcohol (for epoxy clean up)
- 8-32 Tap and drill set (GPMR8103)
- #1 Hobby knife (HCAR0105)
- #11 Blades (5-pack, HCAR0211)

Optional Supplies & Tools

Here is a list of optional tools mentioned in the manual and others items that will help you build the Yak 54 1.60 ARF.

- Fuel filler valve for glow fuel (GPMQ4160)
- Fuel filler valve for gasoline (GPMQ4161)
- 1/2 oz. [15 g] Thick Pro CA- (GPMR6013)
- Milled fiberglass (GPMR6165)
- Tap handle (GPMR8120)
- Stick-on segmented lead weights (GPMQ4485)
- Large scale single-sided servo arm (GPMM1100)
- Epoxy brushes (6, GPMR8060)
- Mixing sticks (50, GPMR8055)
- Mixing cups (GPMR8056)
- Builder's Triangle Set (HCAR0480)
- 36" Metal ruler (HCAR0475)
- Pliers with wire cutter (HCAR0630)
- Hobbico Duster™ can of compressed air (HCAR5500)
- Masking tape (TOPR8018)
- Panel Line Pen (TOPQ2510)
- Rotary tool such as Dremel®
- Rotary tool reinforced cut-off wheel (GPMR8200)
- Servo horn drill (HCAR0698)
- Dead Center™ Engine Mount Hole Locator (GPMR8130)

- CG Machine™ (GPMR2400)
- #64 Rubber bands (1/4 lb [113 g] box, HCAQ2020)
- Semi-Flexible Pushrod System (GPMQ3714)

IMPORTANT BUILDING NOTES

- There are two types of screws used in this kit:
- **Sheet metal screws (SMS)** are designated by a number and a length. For example #6 x 3/4" [19 mm]

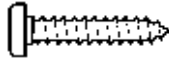

This is a number six screw that is 3/4" [19 mm] long.

- **Machine screws (MS)** are designated by a number, **threads per inch**, and a length. For example 4-40 x 3/4" [19 mm].

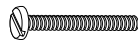

This is a number four screw that is 3/4" [19 mm] long with forty threads per inch.

- **Socket head cap screws (SHCS)** are designated by a number, **threads per inch**, and a length. For example 4-40 x 1-1/2" [38 mm]



This is a number four screw that is 1-1/2" [38 mm] long with forty threads per inch.

- When you see the term **test fit** in the instructions, it means that you should first position the part on the assembly **without using any glue**, then slightly modify or *custom fit* the part as necessary for the best fit.
- Whenever the term **glue** is written, you should rely upon your experience to decide what type of glue to use. When a specific type of adhesive works best for that step, the instructions will make a recommendation.
- Whenever just **epoxy** is specified, you may use **either** 30-minute (or 45-minute) epoxy **or** 6-minute epoxy. When 30-minute epoxy is specified, it is **highly** recommended that you use only 30-minute (or 45-minute) epoxy, because you will need the working time and/or the additional strength.
- **Photos** and **sketches** are placed **before** the step they refer to. Frequently you can study photos in following steps to get another view of the same parts.
- The Yak 54 is factory-covered with Top Flite® MonoKote® film. Should repairs ever be required, MonoKote can be

patched with additional MonoKote purchased separately. MonoKote is packaged in six-foot rolls, but some hobby shops also sell it by the foot. If only a small piece of MonoKote is needed for a minor patch, perhaps a fellow modeler would give you some. MonoKote is applied with a model airplane covering iron, but in an emergency a regular iron could be used. A roll of MonoKote includes full instructions for application. Following are the colors used on this model and order numbers for six foot rolls.

Metallic Blue – TOPQ0402
Metallic Red – TOPQ0405
White – TOPQ0204

- The stabilizer and wing incidences and engine thrust angles have been factory-built into this model. However, some technically-minded modelers may wish to check these measurements anyway. To view this information visit the web site at www.greatplanes.com and click on "Technical Data." Due to manufacturing tolerances which will have little or no effect on the way your model will fly, please expect slight deviations between your model and the published values.

ORDERING REPLACEMENT PARTS

Replacement parts for the Great Planes Yak 54 ARF are available using the order numbers in the **Replacement Parts List** that follows. The fastest, most economical service can be provided by your hobby dealer or mail-order company.

To locate a hobby dealer, visit the Hobbico web site at www.hobbico.com. Choose "Where to Buy" at the bottom of the menu on the left side of the page. Follow the instructions provided on the page to locate a U.S., Canadian or International dealer.

Parts may also be ordered directly from Hobby Services by calling (217) 398-0007, or via facsimile at (217) 398-7721, but full retail prices and shipping and handling charges will apply. Illinois and Nevada residents will also be charged sales tax. If ordering via fax, include a Visa® or MasterCard® number and expiration date for payment.

Mail parts orders and payments by personal check to:

Hobby Services
3002 N. Apollo Drive, Suite 1
Champaign, IL 61822

Be certain to specify the order number exactly as listed in the **Replacement Parts List**. Payment by credit card or personal check only; no C.O.D.

If additional assistance is required for any reason contact Product Support by e-mail at productsupport@greatplanes.com, or by telephone at (217) 398-8970.

METRIC CONVERSIONS

Replacement Parts List

Order Number	Description	How to Purchase
	Missing pieces	Contact Product Support
	Instruction manual	Contact Product Support
	Full-size plans	Not available
GPMA2871	Wing Kit	Contact Hobby Supplier
GPMA2872	Fuse Kit	Contact Hobby Supplier
GPMA2873	Tail Set	Contact Hobby Supplier
GPMA2874	Cowl	Contact Hobby Supplier
GPMA2875	Canopy	Contact Hobby Supplier
GPMA2876	Landing Gear	Contact Hobby Supplier
GPMA2877	Wheel Spats	Contact Hobby Supplier
GPMA2878	Tail Wheel Assembly	Contact Hobby Supplier
GPMA2879	Decal Sheet	Contact Hobby Supplier

1" = 25.4 mm (conversion factor)

1/64" = .4 mm	3/4" = 19.0 mm
1/32" = .8 mm	1" = 25.4 mm
1/16" = 1.6 mm	2" = 50.8 mm
3/32" = 2.4 mm	3" = 76.2 mm
1/8" = 3.2 mm	6" = 152.4 mm
5/32" = 4.0 mm	12" = 304.8 mm
3/16" = 4.8 mm	18" = 457.2 mm
1/4" = 6.4 mm	21" = 533.4 mm
3/8" = 9.5 mm	24" = 609.6 mm
1/2" = 12.7 mm	30" = 762.0 mm
5/8" = 15.9 mm	36" = 914.4 mm

COMMON ABBREVIATIONS

Fuse = Fuselage
 Stab = Horizontal Stabilizer
 Fin = Vertical Fin
 LE = Leading Edge
 TE = Trailing Edge
 LG = Landing Gear
 Ply = Plywood
 " = Inches
 mm = Millimeters

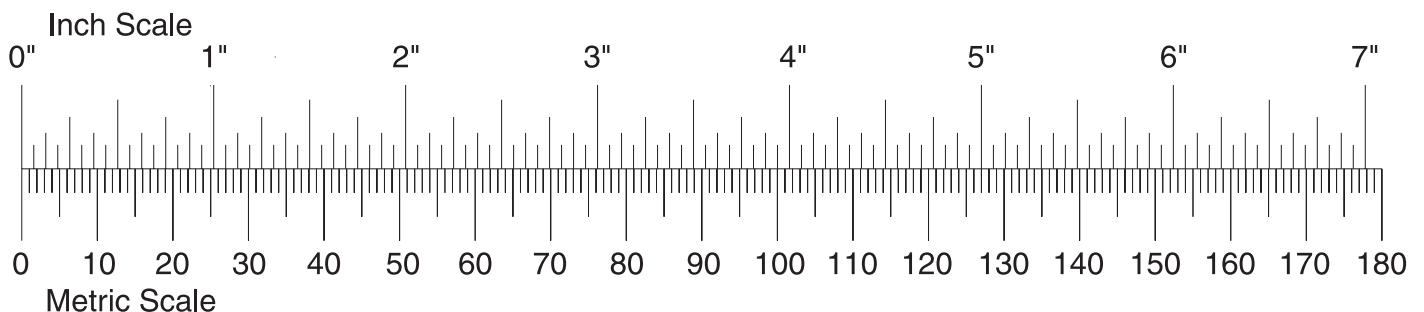

KIT INSPECTION

Before starting to build, take an inventory of this kit to make sure it is complete, and inspect the parts to make sure they are of acceptable quality. If any parts are missing or are not of acceptable quality, or if you need assistance with assembly, contact **Product Support**. When reporting defective or missing parts, use the part names exactly as they are written in the **Kit Contents** list.

Great Planes Product Support
 3002 N. Apollo Drive, Suite 1
 Champaign, IL 61822
 Telephone: (217) 398-8970, ext. 5
 Fax: (217) 398-7721
 E-mail: airsupport@greatplanes.com

KIT CONTENTS

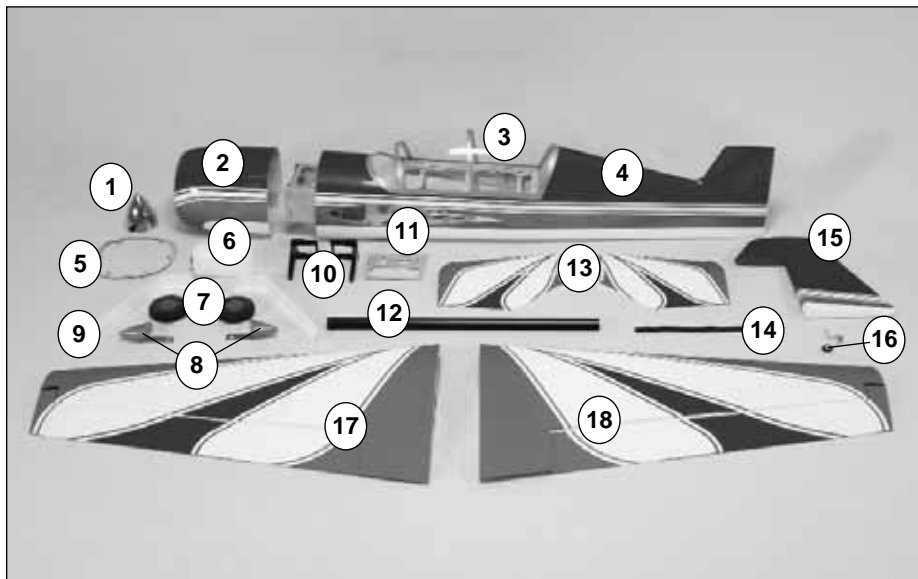

Kit Contents

1. Aluminum Spinner
2. Cowl
3. Canopy
4. Fuselage
5. Cowl Ring
6. Fuel Tank
7. Main Wheels (2)
8. Wheel Spats (L&R)
9. Main Landing Gear (L&R)
10. Engine Mount (L&R)
11. Aft Receiver/Battery Tray
12. Aluminum Wing Tube
13. Horizontal Stabilizer & Elevators
14. Hook & Loop Material
15. Rudder
16. Tailwheel Assembly
17. Left Wing Panel & Aileron
18. Right Wing Panel & Aileron

Kit Contents (not photographed)

- | | | |
|--|--|--|
| <ul style="list-style-type: none"> (8) 4-40 Steel Threaded Clevis (6) Solder Clevis (2) 3/16" [4.8 mm] Axles (1) Screw-Lock Pushrod Connector (for throttle pushrod) (4) Heavy-Duty Screw-Lock Pushrod Connector (for rudder servos) (8) 4-40 Hex Nuts (6) 6-32 Blind Nuts (2) 5/16" x 24 Lock Nuts (4) 3/32" [2.4 mm] Push Nuts (retainers for heavy-duty screw-lock connectors) (1) Nylon Clevis (for throttle pushrod) (6) Heavy-Duty Nylon Control Horn (1) Retainer for Screw-Lock Pushrod Connector (13) 1/4" [6 mm] Clevis Retainers (8) 2-56 x 3/8" [9.5 mm] Phillips Screw (4) 6-32 x 1/4" [6 mm] SHCS (24) #4 x 5/8" [16 mm] SMS | <ul style="list-style-type: none"> (5) 4-40 x 1/4" [6 mm] SHCS (for screw-lock pushrod connectors) (6) 6-32 x 5/8" [16 mm] SHCS (4) 4-40 x 1" [25 mm] SHCS (10) 4-40 x 1/2" [13 mm] SHCS (4) 8-32 x 1-1/4" [32 mm] SHCS (4) 8-32 x 1" [25 mm] SHCS (2) 1/8" x 3" [3 x 76 mm] Heat-Shrink Tubing (6) 3/8" x 3" [9.5 x 76 mm] Heat-Shrink Tubing (4) 3/16" [4.8 mm] Wheel Collars (1) .074 x 12" [305 mm] Wire Threaded One End (6) 4-40 x 12" [305 mm] Wire Threaded One End (10) #4 Lock Washers (10) #4 Flat Washers (8) #2 Flat Washers (8) #8 Split Ring Lock Washers (8) #8 Flat Washers | <ul style="list-style-type: none"> (6) #6 Lock Washers (19) Hinge Points (4) 5/16" [8 mm] Anti-Rotation Pins (2) Long Tie-Straps (10) Cowl Alignment Disks (1) Throttle Servo Tray (1) 3/8"-24 Spinner Adapter (1) 5 x 54 mm Spinner Screw (1) 5 x 70 mm Spinner Screw (1) 5 mm Nut (2) 1/4"-20 Nylon Wing Bolts (2) Canopy Alignment Pegs (1) Pull-Pull Rudder System (includes pull-pull cable, brass couplers, swages, aluminum servo arm extensions, and joiner rods) |
|--|--|--|

PREPARATIONS

1. If you have not done so already, remove the major parts of the kit from the box and inspect for damage. If any parts are damaged or missing, contact Product Support at the address or telephone number listed in the “*Kit Inspection*” section on page 7.



2. Carefully remove the tape and separate all the control surfaces. Use a covering iron with a covering sock to tighten the covering if necessary. Apply pressure over sheeted areas to thoroughly bond the covering to the wood.



2. The hinge points should seat into the hinge holes all the way to the metal pin in order to minimize the gap between the aileron and wing. Use a hobby knife to enlarge the surface of the hinge holes as necessary until the proper fit is achieved. Test fit the aileron to the wing. The hinge gap between the aileron and wing should only be wide enough to allow a small line of light through. Excessive gap will decrease the effectiveness of the ailerons.

3. Apply a small amount of petroleum jelly or something similar to the center of each hinge to prevent epoxy from sticking to the joints and preventing the hinge from operating smoothly.

Read all of Step 4 before proceeding.

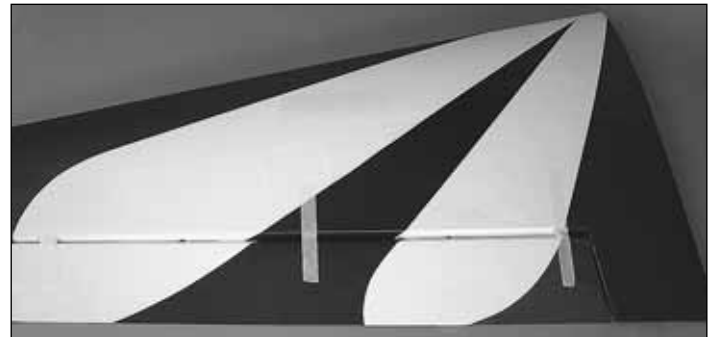

4. Mix up a 1/2 oz. [15 cc] of 30-minute epoxy. Using a toothpick or wood scrap, apply epoxy to the inside of each hinge point hole. The holes are drilled through to the open cavity in the wing, so be careful that you do not apply too much to the walls of the holes as it will simply drip into the wing. Apply a light coat of epoxy to one end of all the hinges for one wing panel. Insert the hinge points into the holes in the wing panel. Wipe away excess epoxy with a paper towel and denatured alcohol. Be sure the hinges are inserted in the correct orientation. Apply epoxy to the other ends of the hinges and slide the aileron into position. Use masking tape to hold the aileron in place while the epoxy cures.

ASSEMBLE THE WING

Install the Ailerons

Do the left wing first so your work matches the photos the first time through. You can do one wing at a time, or work on them together.



1. Test fit the included hinge points into the pre-drilled holes in the **wing panel** and **aileron**. Press the hinge points into the holes.



5. Cut the covering 1/8" [3 mm] inside the opening in the wing for the aileron servo. Use a trim iron to seal the covering to the inner edges of the opening.

6. Repeat these steps for the right wing panel.

Install the Aileron Servos & Pushrods

1. Installing the servos in the wing will require the use of one 24" [610 mm] servo extension for each aileron servo. One Y-harness connector is required and is used to allow the aileron servos to plug into one slot in your receiver. You may have a computer radio that allows you to plug the servos into separate slots and then mix them together through the radio transmitter. If you choose to mix them together with the radio rather than a Y-harness, refer to the manual with your particular model radio system.

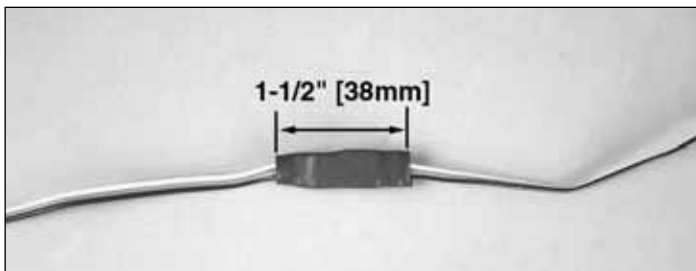

2. Attach the 24" [610 mm] servo extension to the aileron servo and secure it with a piece of the included large heat-shrink tubing. Only 1-1/2" [38 mm] of heat-shrink tubing is required for each connector.



3. Tie the string from inside the opening for the aileron servo to the end of the servo extension. Remove the tape holding the other end of the string to the wing root rib and pull the servo wire and extension through the wing.



4. Temporarily position the aileron servo into the servo bay. Drill a 1/16" [1.6 mm] hole through the four mounting holes of the servo, drilling through the plywood mounting

plate in the wing. Install and remove a servo mounting screw into each of the four holes. Apply a drop of thin CA into the holes to harden the wood. After the glue has cured, install the servo into the opening using the hardware that came with your servo. Center the servo with your radio system and install a servo arm as shown.

The next three images are used for steps 5 and 6.

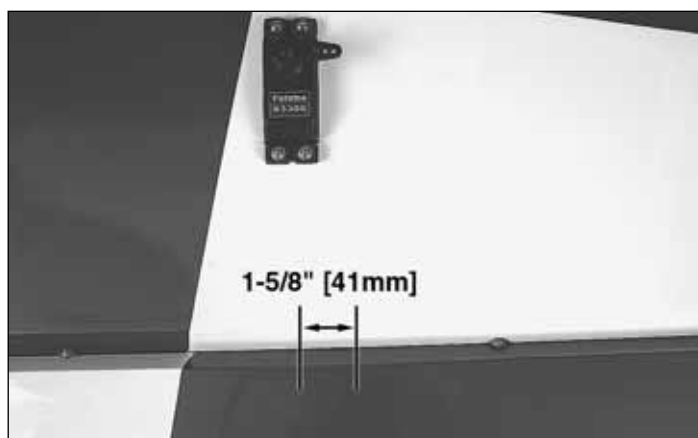
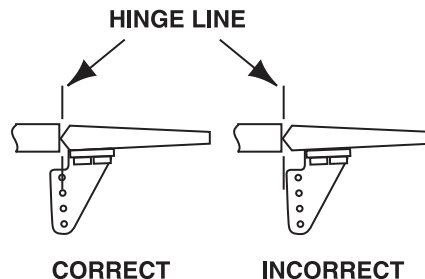

5. The aileron has a plywood plate for mounting the control horn. You can see the outline of it underneath the covering by looking at the aileron at a shallow angle. If you cannot see it, the plate is approximately 1-5/8" [41 mm] wide and will be centered with the servo arm. Use a T-pin to lightly puncture the covering to be sure you are over the plywood plate.

6. Place a heavy-duty nylon control horn on the aileron, positioning it over the hinge line as shown in the sketch and aligning it with the servo arm. Mark the location for the screw holes. Drill through the marks you made with a 3/32" [2.4 mm] drill bit. (Be sure you are drilling into the plywood plate mounted in the bottom of the aileron.) Drill through the plate only. Do not

drill all the way through the aileron!) Using a #4 x 5/8" [16 mm] sheet metal screw, install and then remove a screw into each of the holes. Harden the holes with thin CA. Install the control horn with four #4 x 5/8" [16 mm] sheet metal screws.

❑ 7. Locate a .095" x 12" [2.4 x 305 mm] pushrod wire threaded on one end. Thread a 4-40 nut, a silicone clevis retainer and a threaded metal clevis onto the threaded end of the wire 20 turns. Tighten the nut against the clevis and then install the clevis on the middle hole of the aileron control horn.

❑ 8. Be sure the aileron servo is centered. Install a 4-40 metal solder clevis onto the outer most hole in the servo arm. Center the servo arm and center the aileron. Using the solder clevis as a guide, mark where to cut the pushrod wire. Remove the pushrod and clevis from the control horn and the solder clevis from the servo arm. Cut the pushrod to length. Install another silicone clevis retainer onto the wire and solder the clevis to the pushrod using the **Expert Tip** that follows.



How to solder the clevis to the pushrod

1. Where the pushrod will make contact with the solder clevis, roughen the wire with 220-grit sandpaper.
2. Use a denatured alcohol to remove any oil residue from the wire pushrod.
3. Apply a couple of drops of flux to the wire. Slide the solder clevis onto the wire. Using a small torch or soldering iron, heat the wire, allowing the heated wire to heat the solder clevis. Apply a small amount of solder to the joint. When the wire and clevis are hot enough, the solder will flow into the joint. Avoid using too much solder, causing solder to flow out of the joint and clump. Use just enough solder to make a good joint. Allow the wire and clevis to cool.
4. Put a couple of drops of oil onto a rag and wipe the joint. This will prevent rust from forming on the joint.

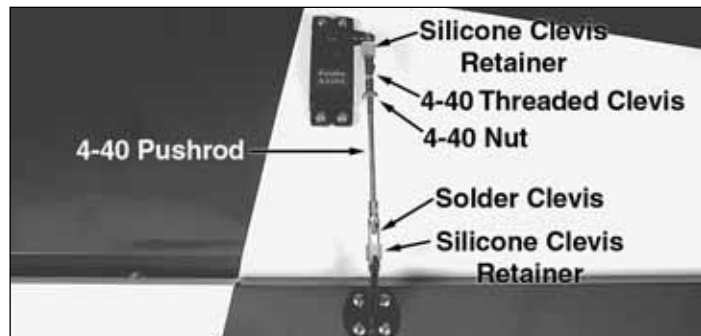

❑ 9. Install the pushrod and clevises to the outer hole in the servo arm and the middle hole in the control horn. Adjust

the linkage until the aileron and the servo arm are both centered. Then, tighten the nut against the clevis. Slide the two silicone clevis retainers to the end of each clevis.

❑ 10. Repeat these steps for the right wing panel.

Finish the Wing

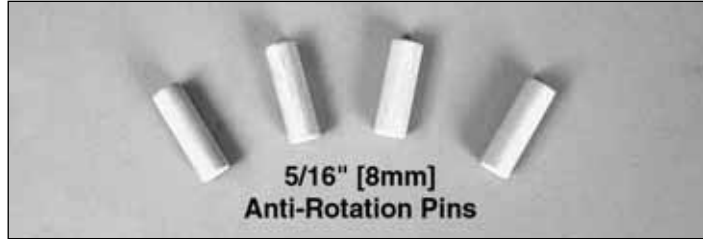

❑ 1. Locate the four 5/16" [8 mm] diameter anti-rotation pins.

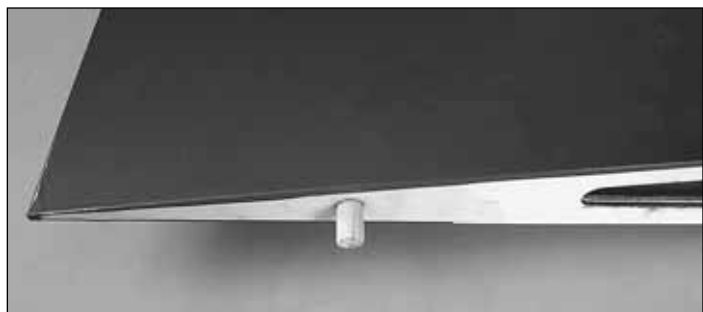
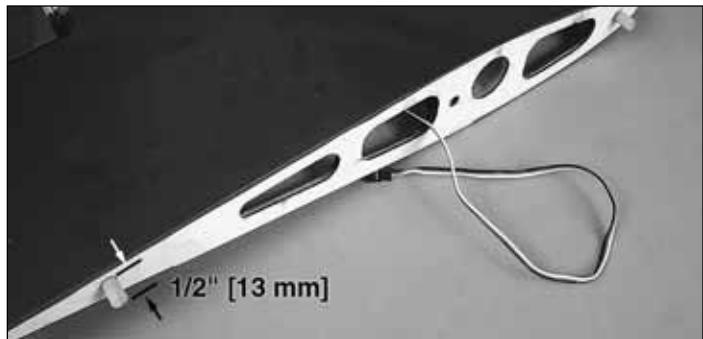

❑ 2. Using 6-minute epoxy, coat half of the anti-rotation pins and insert them into the forward and aft holes in the wing panel root ribs. It may be necessary to **carefully** tap them into place. The pins should extend out approximately 1/2" [13 mm]. Wipe away any excess epoxy with a paper towel and denatured alcohol before the epoxy cures.

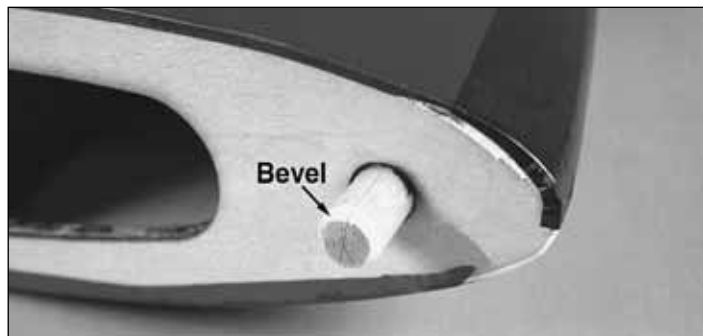

❑ 3. Use sandpaper to bevel the ends of the anti-rotation pins to ease their insertion into the **fuselage**.

ASSEMBLE THE FUSELAGE

Install the Rudder & Tail Gear

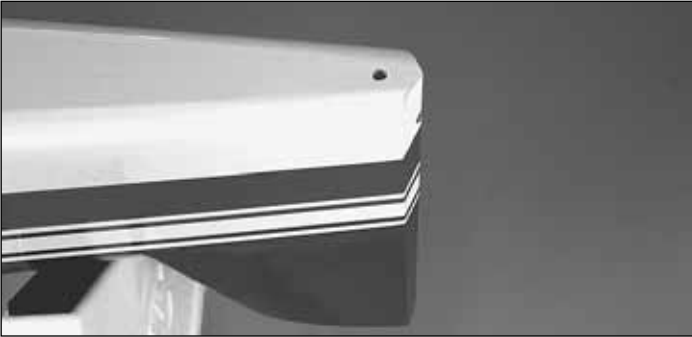

1. Trim the covering from the fuselage for the **tail wheel bushing**.

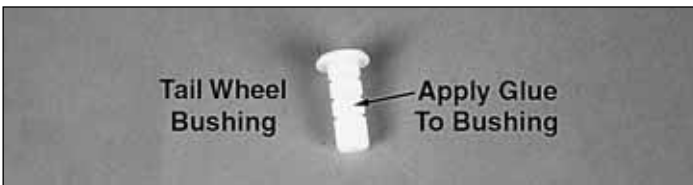

2. Apply CA or epoxy to the bushing and then, insert it into the hole by gently tapping it into place until fully seated. Be sure not to get glue into the hole in the bushing.

3. Just as you did with the ailerons, prepare the hinge point holes in the **rudder** and fuselage by test fitting the hinges and enlarging the holes as necessary.

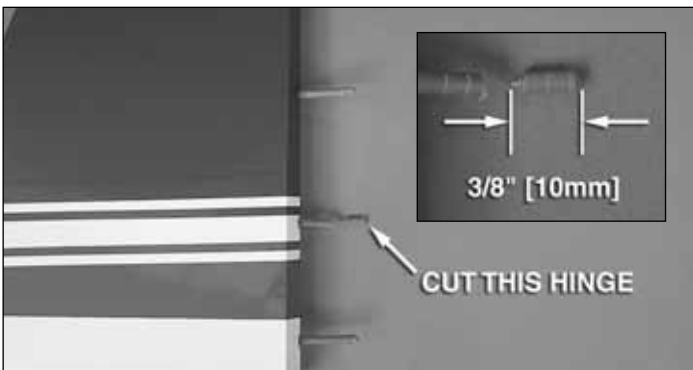

4. Cut away 3/8" [10mm] from one end of the hinge that will be installed in between the small blue and red stripes (the hinge that is second from the bottom on the rudder). The end that has been cut should be the end that gets installed into the fuselage. Doing so will prevent this hinge from interfering with the installation of the horizontal stabilizer.

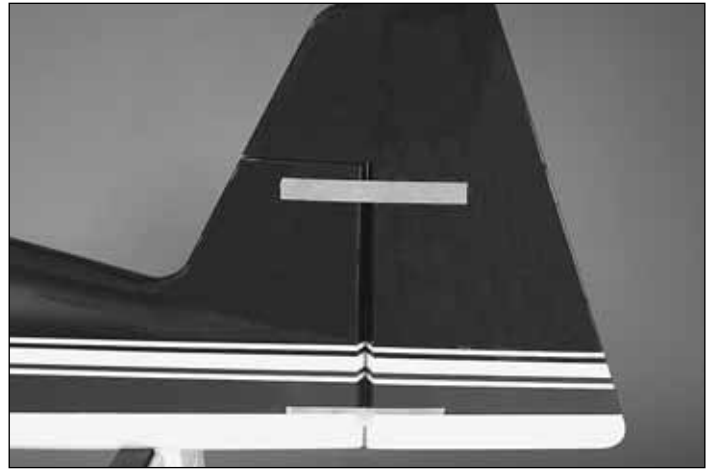

5. Mix up 1/4 oz. [7.5 cc] of 30-minute epoxy. Using a toothpick or wood scrap, apply epoxy to the inside of each hinge point hole. Apply a light coat of epoxy to one end of all the hinges for the rudder. Insert the hinge points into the holes, wiping away excess epoxy with a paper towel and denatured alcohol. Be sure the hinges are inserted in the correct orientation. Apply epoxy to the other ends of the hinges and slide the rudder into place. Use masking tape to hold the rudder in position while the epoxy cures.

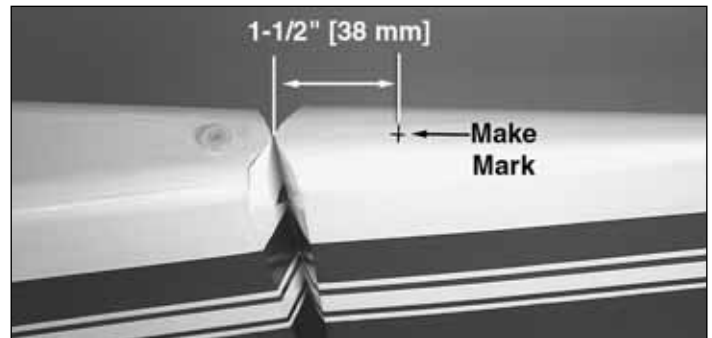

6. Measure 1-1/2" [38 mm] back from the leading edge bevel of the rudder and make a mark on the underside center of the rudder.

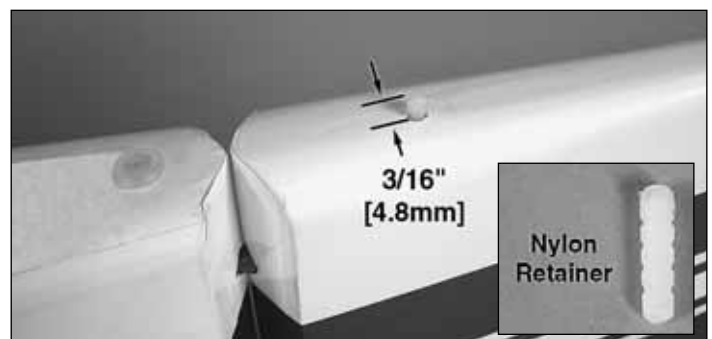

7. Use a 5/32" [4 mm] drill bit to make a 1/2" [13 mm] deep hole at the mark. Insert the **nylon retainer** into the hole by tapping it gently, leaving 3/16" [4.8 mm] extending outside the hole. Align the hole to run parallel with the rudder.

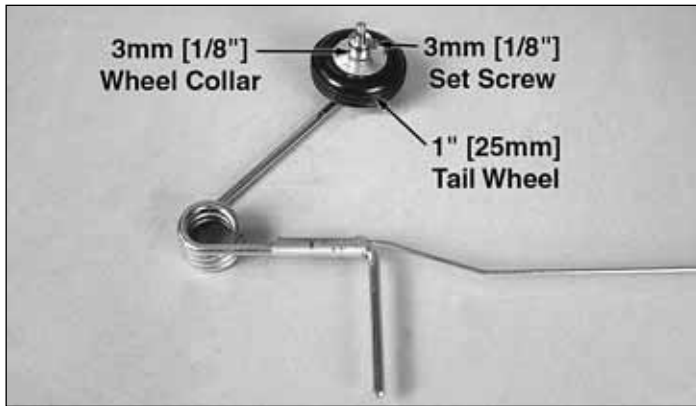

❑ 8. Slide the 1" [25 mm] **tail wheel** onto the **tail gear assembly** and secure it with a 3mm [1/8"] set screw and 3mm [1/8"] wheel collar. Be sure that the tail wheel rotates freely. Oil the tail wheel axle if necessary.

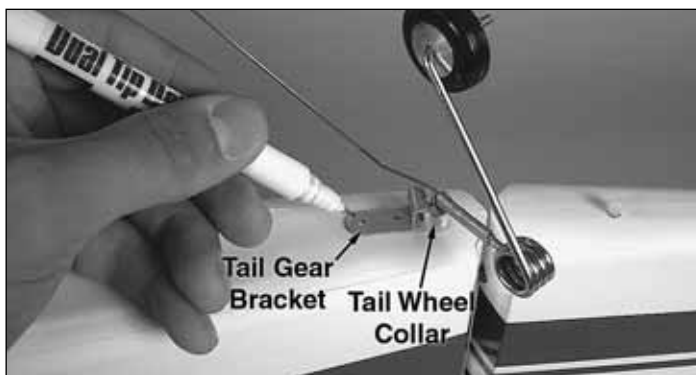

❑ 9. Slide the large 3mm [1/8"] tail wheel collar onto the base of the tail gear and temporarily insert the assembly into the tail wheel bushing. Center the tail gear bracket on the fuselage against the tail wheel collar as shown. Mark the location of the two holes in the bracket on the fuselage.

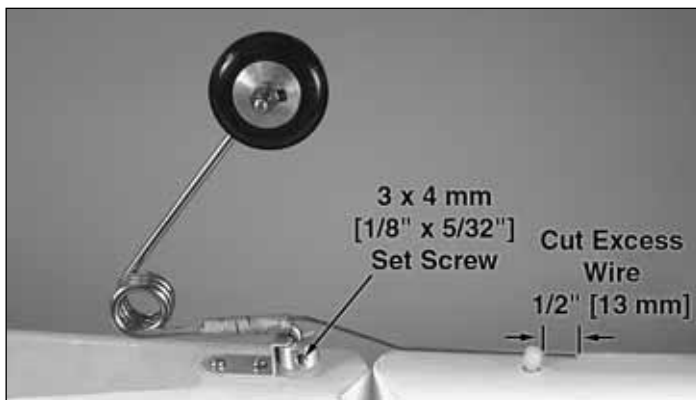

❑ 10. Drill 1/16" [1.6 mm] diameter holes at the marks. Thread a 2 x 8mm [5/64" x 5/16"] self-tapping screw into each of the holes and remove it. Add a drop of thin CA glue to harden the holes. Now secure the tail gear assembly to the fuselage by sliding the guide wire through the nylon retainer and inserting the base of the tail gear into the bushing. Use a 3 x 4mm set screw to tighten the tail wire collar to the tail gear and install the bracket with two 2 x 8mm [5/64" x 5/16"] self-tapping screws. Cut off the excess guide wire leaving 1/2" [13 mm] beyond the retainer. Add a few drops of thin CA to the nylon retainer being sure not to get glue on the guide wire or in the hole.

Assemble & Install the Main Gear

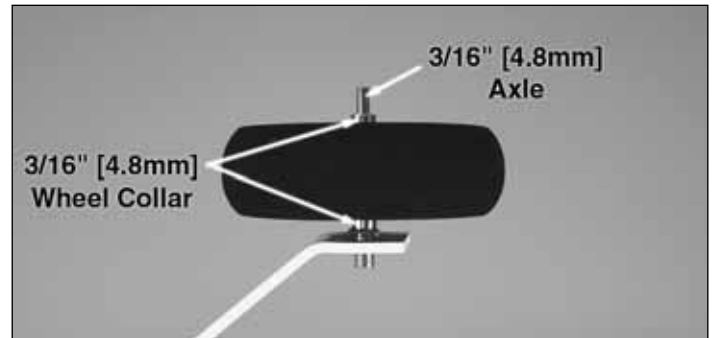

❑ 1. Temporarily assemble the **main landing gear** by inserting the 3/16" [4.8 mm] axles into the holes in the main gear. Slide a 3/16" [4.8 mm] wheel collar, 4" [102 mm] main wheel, and then another 3/16" [4.8 mm] wheel collar onto each axle. Mark the locations of the wheel collar screws onto the axles. Remove the wheel collars and wheels from the axles and file or grind flat spots at the marks for the wheel collar screws to tighten against.



❑ 2. Reassemble the gear, securing the axles with 5/16" x 24 lock nuts. Using four 4-40 x 1/2" [13 mm] SHCS and four 4-40 lock nuts, attach the wheel spats to the landing gear as shown. Loosely thread four 6-32 x 1/4" [6 mm] SHCS into the wheel collars. Slide a wheel collar, 4" [102 mm] wheel, and another wheel collar onto each axle and tighten the collar screws onto the flat spots on the axles. Be sure that the wheels rotate freely.



❑ 3. Locate the slots in the fuselage for the main landing gear and trim the covering away.

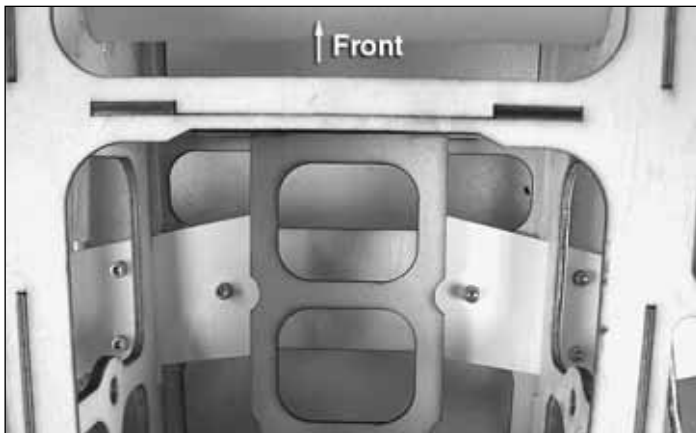
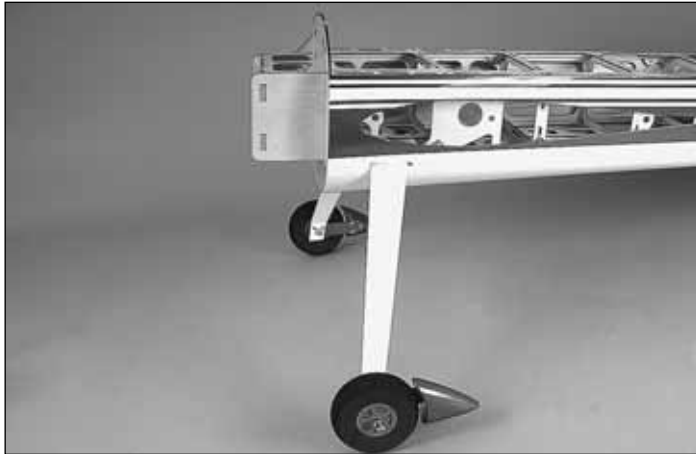

❑ 4. Attach the landing gear to the fuselage using six 6-32 x 5/8" [16 mm] SHCS and six #6 lock washers. Apply thread-locking compound to the socket head cap screws. Be careful not to push the pre-installed blind nuts out of the landing gear mounting rails when threading in the socket head cap screws.

Install the Elevators & Stabilizer

❑ 1. Just as you did with the ailerons and rudder, prepare the hinge point holes in the **stabilizer** and **elevators** by test fitting the hinges and enlarging the holes as necessary.

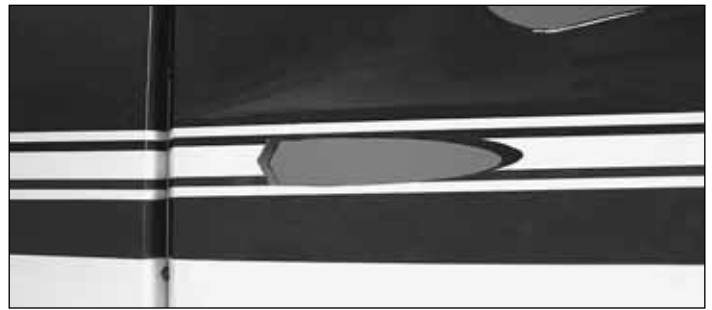

❑ 2. Locate the stabilizer slots near the aft end of the fuselage and trim away the covering. Seal the edges of the slots with a trim iron.

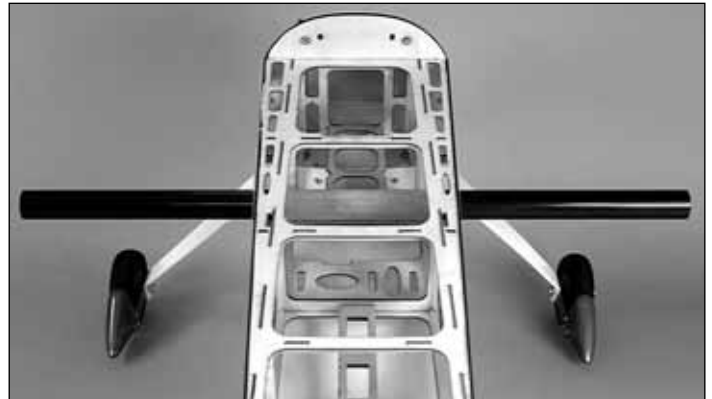

❑ 3. You will need to temporarily install the wing panels in order to align the stabilizer in the fuselage. Slide the black aluminum **wing tube** into the fiberglass joiner tube inside the fuselage and center its position.

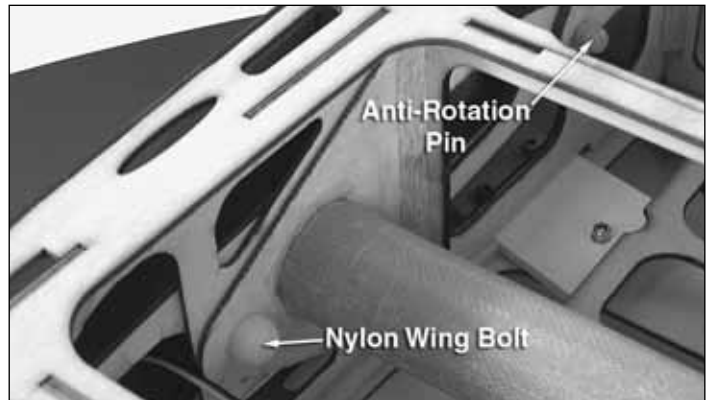
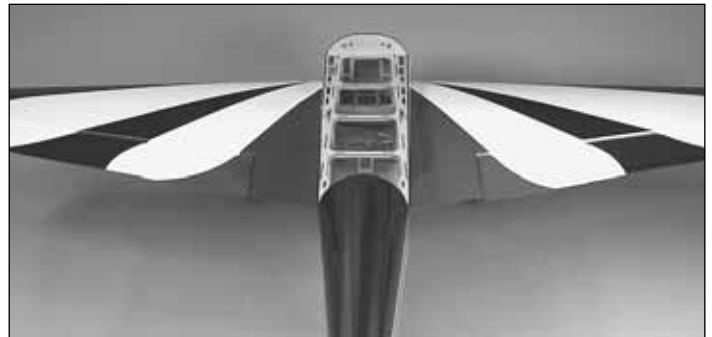

❑ 4. Fit the wing panels onto the wing tube, pushing them into the fuselage until the root ribs are pressed against the inner fuselage formers. The anti-rotation pins will fit into receiving holes in the fuselage. Use the included nylon wing bolts to draw the wing panels in tight.

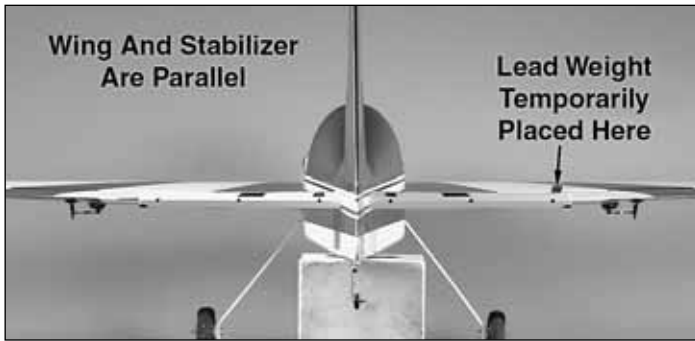

❑ 5. Test fit the stabilizer in the fuselage. Center the stab left and right in the fuselage. Stand back 15 to 20 ft [5 to 6 m] and check to be sure the stab is parallel to the wing. Adjust the stab saddle as needed until the stab and wing are parallel. If necessary, weight can be added to one side of the stabilizer as shown above to bring the stab parallel to the wing. When the stab is glued in place permanently, the same amount of weight will be added temporarily while the epoxy cures.

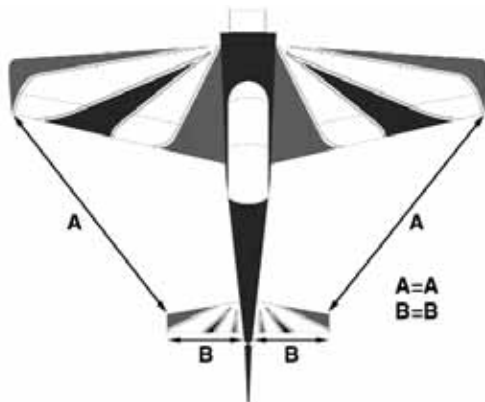

❑ 6. Measure the distance from the tip of each wing to the tip of the stab. Adjust the stab until the distance from the tip of the stab to the tip of the wing is equal on both sides. Center the stab in the fuse left and right.



❑ 7. Use a felt-tip marker to mark the outline of the fuselage onto the top and bottom of the stab.

❑ 8. Remove the stab from the fuse. Use a sharp #11 hobby knife or use the following **Expert Tip** to cut the covering 1/16" [1.6 mm] inside of the lines you marked. Use care to cut only in the covering and not into the wood.



How to cut covering from balsa

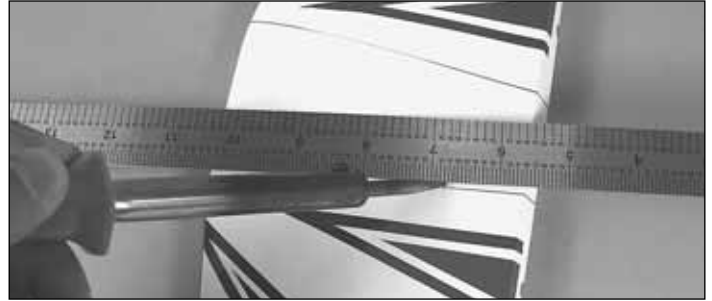

Use a soldering iron to cut the covering from a balsa sheeted surface. The tip of the soldering iron doesn't have to be sharp, but a fine-tip does work best. Allow the iron to heat fully. Use a straightedge to guide the soldering iron at a rate that will just melt the covering and not burn into the wood. The hotter the soldering iron, the faster it must travel to melt a fine cut. Peel off the covering.

❑ 9. Use 30-minute epoxy to glue the stab into the fuselage. For the most strength, apply epoxy to both sides of the stab and inside the fuse where the stab fits. Slide the stab into position. Wipe away any excess epoxy with a paper towel and denatured alcohol. Do not disturb the model until the epoxy has fully hardened.



❑ 10. Mix up 1/4 oz. [7.5 cc] of 30-minute epoxy. Using a toothpick or wood scrap, apply epoxy to the inside of each hinge point hole. Apply a light coat of epoxy to one end of all the hinges for the elevators. Insert the hinge points into the holes, wiping away excess epoxy with a paper towel and denatured alcohol. Be sure the hinges are inserted in the correct orientation. Apply epoxy to the other ends of the hinges and slide the elevators into place. Use masking tape to hold the elevators in position while the epoxy cures.

Install the Elevator Servos & Linkage

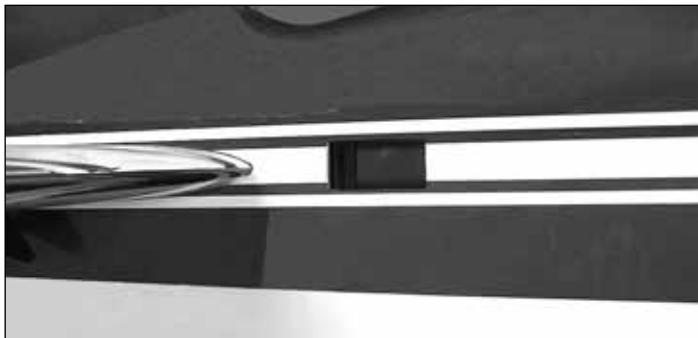

❑ 1. Locate the cutouts for the elevator servos on both sides of the fuselage just forward of the horizontal stabilizer. Cut the covering 1/8" [3mm] inside the openings. Use a trim iron to seal the covering to the inner edges of the opening.

❑ 2. Attach a 36" [914 mm] servo extension to each elevator servo. Secure the connections with heat-shrink tubing.



❑ 3. Temporarily position the elevator servos into the servo bays. Drill a 1/16" [1.6 mm] hole through the four mounting holes of each servo, drilling through the plywood mounting plates in the fuselage. Install and remove a servo mounting screw into each of the eight holes. Apply a drop of thin CA into the holes to harden the wood. After the glue has cured, install the servos into the openings using the hardware that came with your servos. Center the servos with your radio system and install servo arms as shown.



❑ 4. Just as you did with the ailerons, look closely on the bottom of the elevators and you will notice a plywood plate visible under the covering. Place a heavy-duty nylon control horn on each of the elevators, positioning it as shown and aligning it with the servo arm. Mark the location for the screw holes. Drill through the marks you made with a 3/32" [2.4

mm] drill bit. (Be sure you are drilling into the plywood plates mounted in the bottom of the elevators. Drill through the plate only. Do not drill all the way through the elevators!) Using a #4 x 5/8" [16 mm] sheet metal screw, install and then remove a screw into each of the holes. Harden the holes with thin CA. Install the control horns with eight #4 x 5/8" [16 mm] sheet metal screws.

❑ 5. Locate two .095" x 12" [2.4 x 305 mm] pushrod wires threaded on one end. Thread a 4-40 nut, a silicone clevis retainer and a threaded metal clevis onto the threaded ends of the wires 20 turns. Tighten the nut against the clevis and then install the clevis on the elevator control horns.



❑ 6. Be sure the elevator servos are centered. Install a 4-40 metal solder clevis onto the outer most hole in each servo arm. Center the servo arms and center the elevators. Using the solder clevis as a guide, mark where to cut the pushrod wire. Remove the pushrods and clevises from the control horns and the solder clevises from the servo arms. Cut the pushrod to length, install another silicone clevis retainer, and solder the clevises to the pushrods.

Install the Rudder Servos & Linkage (Recommended Glow Engine Installation)

Important! Please Read Before Installing the Rudder Servos. This model has the option of two different rudder servo installations. This is to help balance the airplane and accommodate different engine weights. If you are installing a glow engine, you most likely will be a little tail heavy. You will probably wish to install the servos as shown in the "**Install the Rudder Servos & Linkage (Recommended Glow Engine Installation)**" section that follows. If you are installing a gasoline engine, you will most likely need tail weight and should follow the "**Install the Rudder Servos & Linkage (Recommended Gas Engine Installation)**" section instructions starting on page 18. Adding dead weight is something we strive not to do to our models since extra weight detracts from the performance of the airplane. Take a moment to read through both installation methods to determine which is best for your application. If you are unsure which installation is best for your engine choice you may wish to skip the installation of the rudder servos at this time and install them after you balance the airplane.

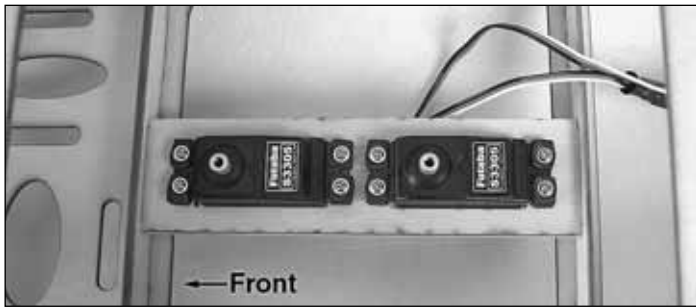

1. Secure a 6" [152 mm] servo extension to each rudder servo. Position the rudder servos into the servo tray as shown and mark the mounting hole locations. Drill a 1/16" [1.6 mm] hole through the mounting holes of each servo. Install and remove a mounting screw from each hole and apply a drop of thin CA into the holes to harden the wood. After the glue has cured, install the servos into the openings using the hardware that came with your servos. Center the servos with your radio system.

2. Trim the covering from the rudder cable exit slots as shown in step 3.



3. Locate the plywood mounting plates beneath the covering on both sides of the rudder. Place a heavy-duty nylon control horn on each side of the rudder. Position them as shown, aligning them with the slots for the rudder cable. Mark the location for the screw holes. Drill through the marks you made with a 3/32" [2.4 mm] drill bit. Using a #4 x 5/8" [16 mm] sheet metal screw, install and then remove a screw into each of the holes. Harden the holes with thin CA. Install the control horns with eight #4 x 5/8" [16 mm] sheet metal screws.

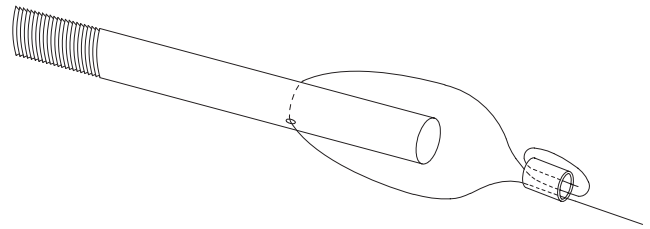
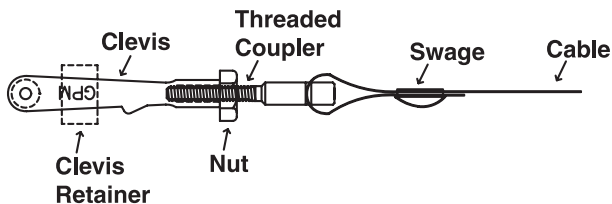

4. Cut the provided pull-pull cable into two equal lengths. Thread a 4-40 nut and a silicone clevis retainer onto each of the four brass pull-pull threaded couplers and then thread the couplers into four 4-40 metal clevises twelve complete turns. Feed only one end of each cable through the hole in the brass coupler 3/4" [19 mm] and fold it back onto itself. Slide a swage onto the cable over the short end, loop the short end around through the swage again, and crimp them together using heavy-duty pliers as shown. The other ends of the cables will be connected to the threaded couplers after being installed into the fuselage.

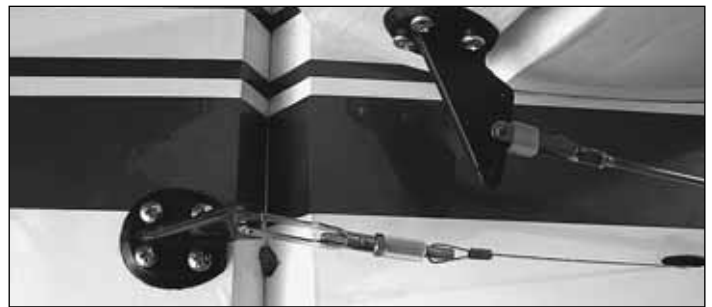

5. Feed the pull-pull wires through the slots in the fuselage near the rudder control horns. Be sure that the other ends make it through the fuselage to the rudder servos. Turning the airplane up on its nose and feeding the cable ends into the fuse makes this task easier.

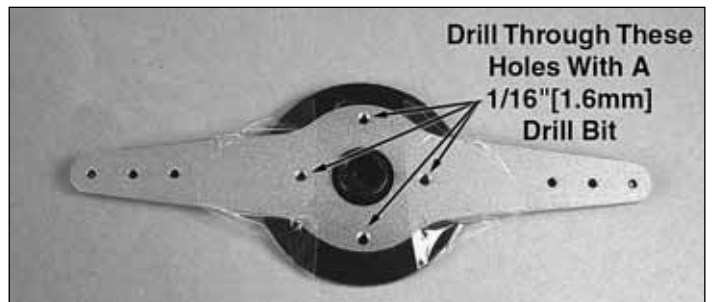
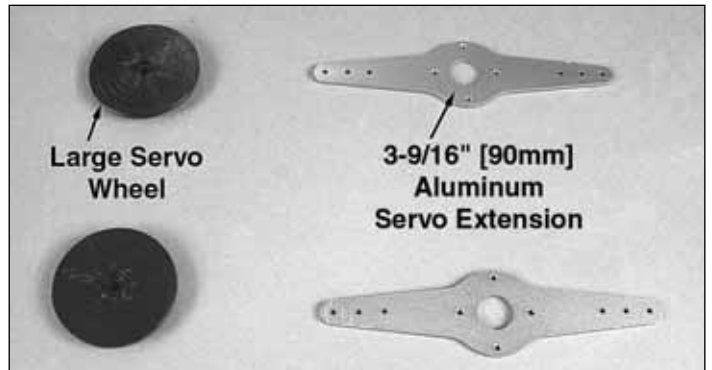

6. Two 3-9/16" [90mm] aluminum servo arm extensions are included for the rudder pull-pull system. Locate the large servo

wheels included with the rudder servos (Different model servos may come with servo wheels that are larger or smaller than the ones shown in the picture. The actual size of the servo wheels being used is not critical.) Fit the aluminum servo extensions to the undersides of the servo wheels and tape them in place. Use a 1/16" [1.6mm] drill bit to drill through the four mounting holes in the servo extensions into the plastic servo wheels. Remove the servo wheels from the extensions and enlarge the holes with a 3/32" [2.4mm] drill bit.

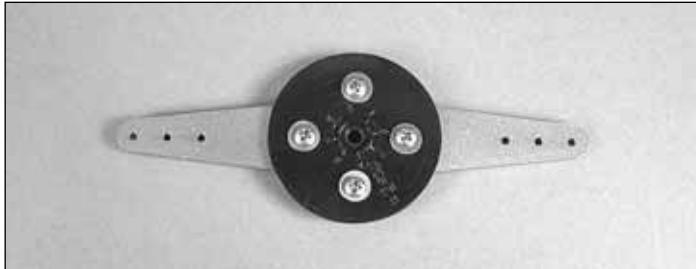

7. Using eight 2-56 x 3/8" [9.5 mm] Phillips screws and eight #2 flat washers, attach the servo extensions to the servo wheels. Apply a drop of thread-locking compound to each screw. With a cut-off wheel, cut off the ends of the screws that protrude from underneath the servo extensions.

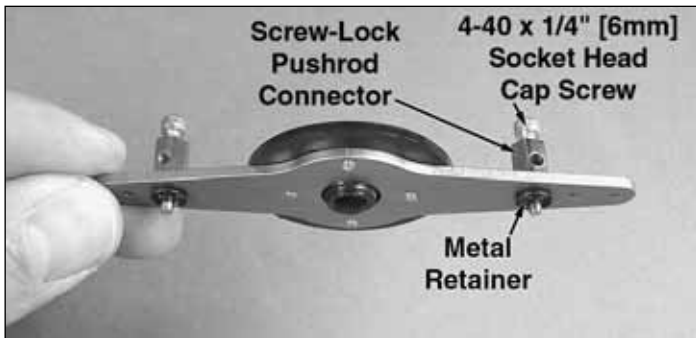

8. Drill out the inner holes of both servo extensions using a 7/64" [2.8 mm] bit. Do not use any other size drill bit for this step. Secure a screw-lock pushrod connector to each arm in the holes you just drilled out with a metal retainer. Thread four 4-40 x 1/4" [6 mm] SHCS loosely into the screw-lock pushrod connectors.

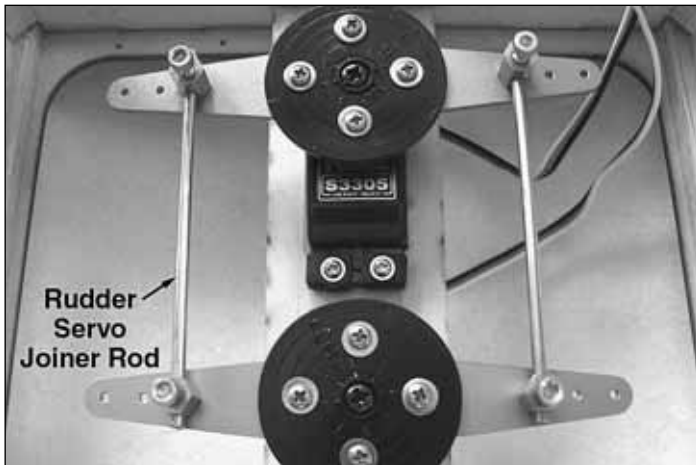

9. With the servos centered, align the servo arms perpendicular with the fuselage and parallel with each other and secure them to the rudder servos with the servo arm

screws. Insert the two rudder servo joiner rods (included with the kit), through the screw-lock pushrod connectors as shown and tighten the 4-40 x 1/4" [6 mm] SHCS. Use wire cutters to cut away the excess joiner rod length.

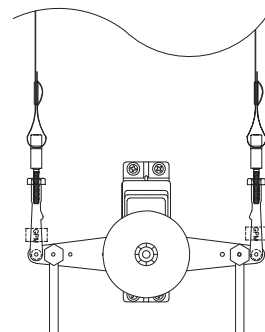
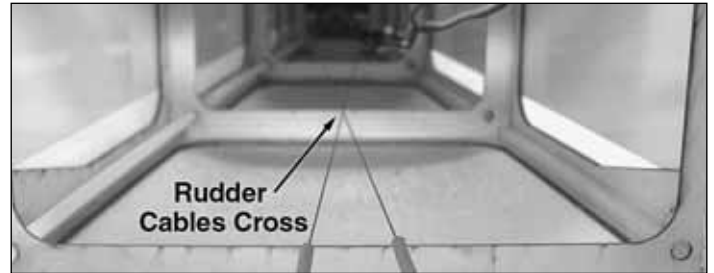

10. Connect the other two clevis ends with the brass couplers installed onto the outer holes of the aft rudder servo arm. Check to be sure that the elevator servo wires are not entangled in the rudder pull-pull cables. Slide a 3" [76 mm] piece of 1/8" [3 mm] heat-shrink tubing and then a swage onto the ends of the pull-pull cables inside the fuselage. Move the rudder to the neutral position and feed the ends of the cables through the holes in the couplers. The pull-pull cables will cross each other inside the fuselage. With both pull-pull cables having tension and the rudder in the neutral position, crimp the swages onto the cable ends to secure them as you did in step 4. You can fine-tune the tension on the lines by threading the clevises up or down on the couplers until satisfied. Then, tighten the 4-40 nuts against the clevises.

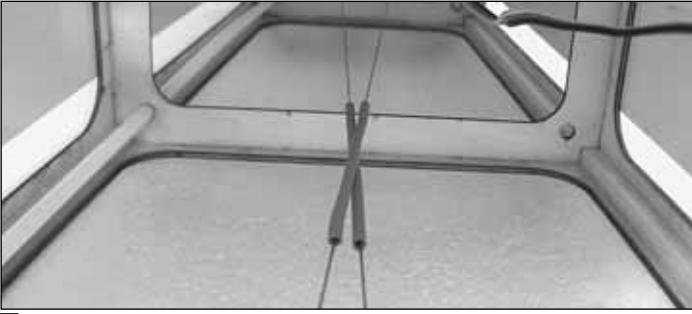

❑ 11. Apply heat to the heat-shrink tubing on the cables. Slide the heat-shrink down the cables toward the tail, centering the pieces on the location where the cables cross each other. This will prevent the metal cables from rubbing against each other which could cause radio interference. With the heat-shrink tubes in place, use medium CA glue to adhere the heat-shrink to the cables. Be careful not to glue the heat-shrink tubes to each other.

Install the Rudder Servos & Linkage (Recommended Gas Engine Installation)

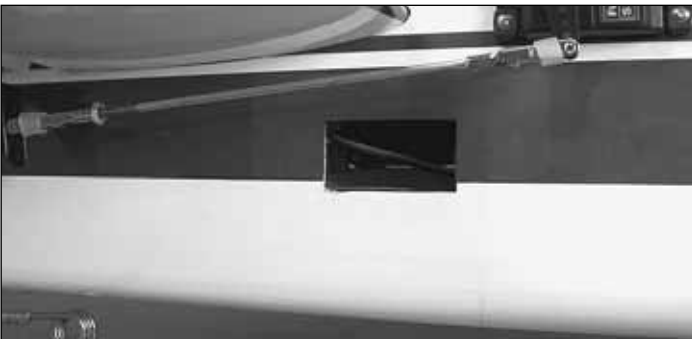

❑ 1. Locate the cutouts for the rudder servos on both sides of the fuselage beneath the horizontal stabilizer. Cut the covering 1/8" [3 mm] inside the openings. Use a trim iron to seal the covering to the inner edges of the opening.

❑ 2. Attach a 36" [914 mm] servo extension to each elevator servo. Secure the connections with heat-shrink tubing.



❑ 3. Temporarily position the rudder servos into the servo bays. Drill a 1/16" [1.6 mm] hole through the four mounting holes of each servo, drilling through the plywood mounting plates in the fuselage. Install and remove a servo mounting screw into each of the eight holes. Apply a drop of thin CA into the holes to harden the wood. After the glue has cured,

install the servos into the openings using the hardware that came with your servos. Center the servos with your radio system and install servo arms as shown.



❑ 4. Just as you did with the ailerons, look closely on the sides of the rudder and you will notice a plywood plate visible under the covering. Place a heavy-duty nylon control horn on each side of the rudder, positioning it as shown and aligning it with the outer hole of the servo arm. Mark the location for the screw holes. Drill through the marks you made with a 3/32" [2.4 mm] drill bit. (Be sure you are drilling into the plywood plates mounted in the rudder. Drill through the plate only. Do not drill all the way through the rudder!) Using a #4 x 5/8" [16 mm] sheet metal screw, install and then remove a screw into each of the holes. Harden the holes with thin CA. Install the control horns with eight #4 x 5/8" [16 mm] sheet metal screws.

❑ 5. Locate two .095" x 12" [2.4 x 305 mm] pushrod wires threaded on one end. Thread a 4-40 nut, a silicone clevis retainer and a threaded metal clevis onto the threaded ends of the wires 20 turns. Tighten the nut against the clevis and then install the clevis on the rudder control horns.



❑ 6. Be sure the rudder servos are centered (with the arms pointing down). Install a 4-40 metal solder clevis onto the outer most hole in each servo arm. Center the servo arms and center the rudder. Using the solder clevis as a guide, mark where to cut the pushrod wire. Remove the pushrods and clevises from the control horns and the solder clevises from the servo arms. Cut the pushrod to length, install another silicone clevis retainer, and solder the clevises to the pushrods.

INSTALL THE ENGINE & FUEL TANK

Glow Engine Installation

If you are installing a brand of glow engine other than the O.S. 1.60 FX, read through the installation instructions for the O.S. 1.60 FX. The procedure should be similar. The most important thing is to be sure to follow the spacing dimensions from the engine drive washer back to the firewall.

If you are installing the Fuji-Imvac BT-43 EI or other gasoline engine, skip ahead to the instructions for mounting that engine. If you will be using another brand of gasoline engine, read through the installation instructions for the Fuji-Imvac BT-43 EI. You should find the mounting instructions for the Fuji-Imvac BT-43 EI helpful in determining the best way to mount your particular brand of gasoline engine.



❑ 1. Cut the template out of the back cover page of this manual for mounting the O.S. 1.60 FX. Use tape or spray adhesive to hold the glow engine mount template to the firewall. Align the vertical and horizontal lines on the template with the embossed lines on the firewall.

❑ 2. Use a large T-pin or a wire sharpened on the end to transfer each bolt hole center mark on the template into the firewall.

❑ 3. Drill 13/64" [5.2 mm] holes at the marks. Apply a few dabs of epoxy to the front of four 8-32 blind nuts. Use an 8-32 x 1-1/4" [32 mm] bolt with a few #8 washers to draw the blind nuts into the back of the firewall.



❑ 4. Attach the **engine mount** to the firewall as shown using four 8-32 x 1-1/4" [32 mm] SHCS, four #8 flat washers and four #8 lock washers. When installing the mount, be

sure that you have the mount positioned allowing the engine to be mounted on its side.

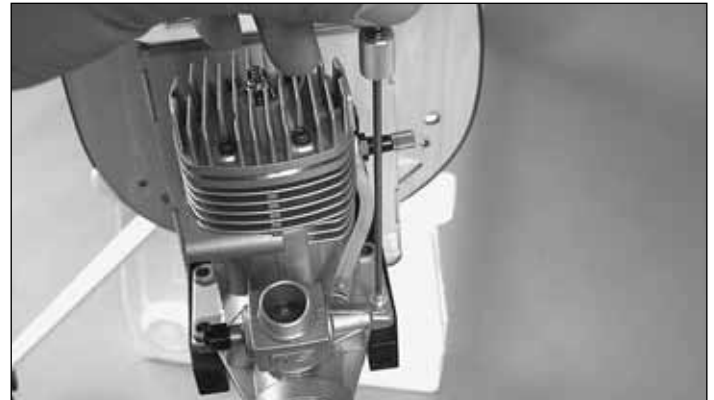
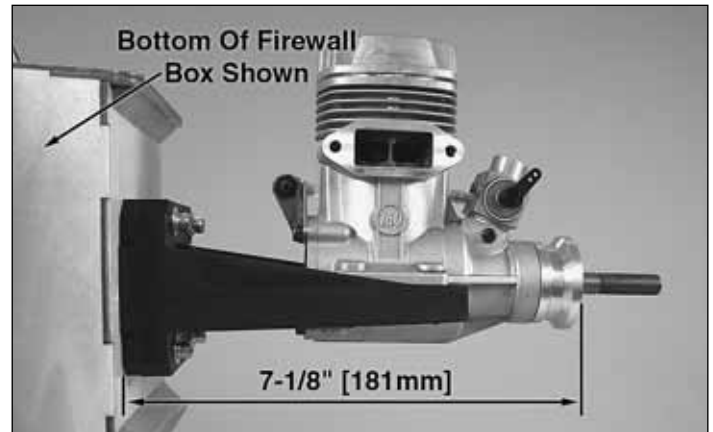

❑ 5. Place the engine in the mount. The distance from the firewall to the front of the drive washer is 7-1/8" [181 mm]. Use a Great Planes Engine Hole Locator or a small drill bit to mark the engine mounting holes into the engine mounts.

❑ 6. Take the engine off the mount. Then drill 9/64" [3.6 mm] holes at the marks. Use an 8-32 tap to cut threads into the holes.

❑ 7. Mount the engine to the mount with four 8-32 x 1" [25 mm] SHCS, four #8 flat washers and four #8 lock washers.

Install the Throttle Servo (Glow Engine)

❑ 1. Connect the throttle servo to a 12" [305 mm] servo extension. Secure the connection using heat-shrink tubing.

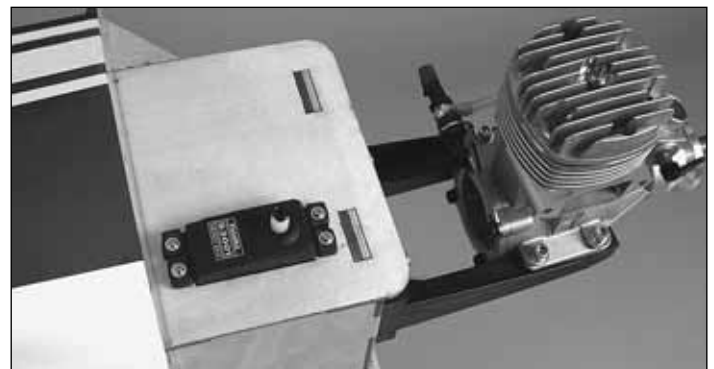

❑ 2. Attach the throttle servo to the firewall box as shown using the hardware included with the servo. Harden the mounting holes with thin CA glue.

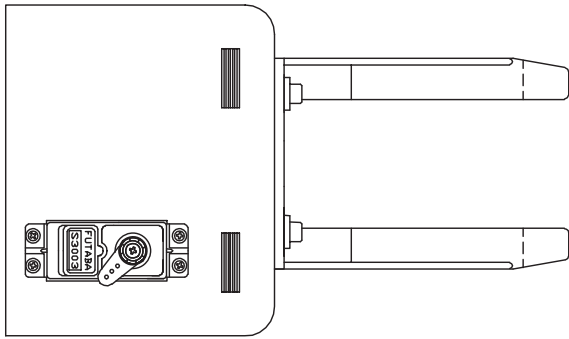

- ❑ 3. Install a servo arm downward and angled towards the rear of the plane.



- ❑ 4. If you have not already done so, install the muffler for your engine. The throttle pushrod will need to be routed so it will clear the muffler.

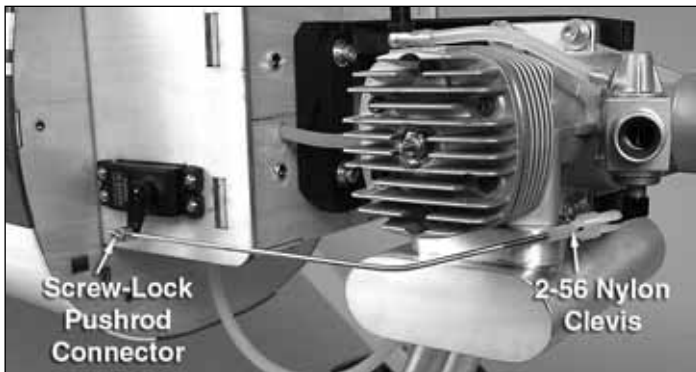
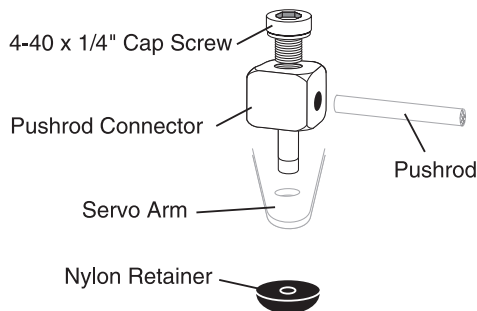

- ❑ 5. Install a brass screw-lock pushrod connector, nylon retainer ring and a 4-40 x 1/4" [6 mm] SHCS onto the outer hole of the servo arm. Bend a .074 x 12" [305 mm] threaded rod to fit from the throttle servo arm to the throttle carburetor

arm. When bending the wire, be sure that you have clearance between the pushrod and any of the engine/muffler components. Metal contact may create radio interference. Thread a 2-56 nylon clevis and silicone clevis retainer onto the threaded rod and connect it to the carburetor.

- ❑ 6. Using your radio system, adjust the throttle servo and carburetor arm movement as desired.

Install the Fuel Tank (Glow Engine)

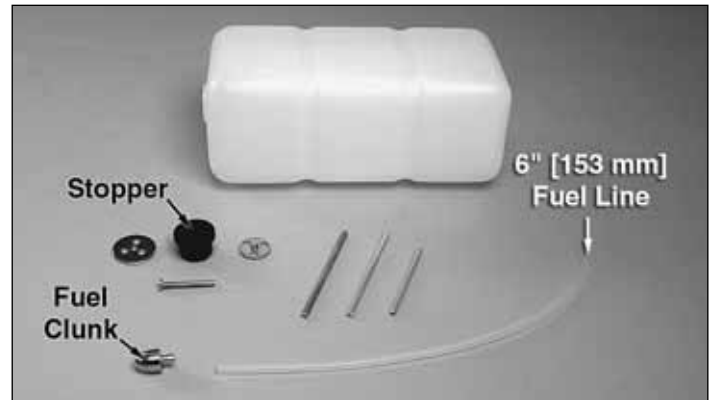

- ❑ 1. Locate the **fuel tank**. The hardware needed for the fuel tank assembly is inside of the tank. Remove the stopper and shake out the contents.

- ❑ 2. The fuel system for the Yak 54 1.60 ARF utilizes a three line system. There is a fill and drain line, carb line, and vent line (to muffler). The fill and drain line will allow fueling and defueling without removing the cowl. The fill line is optional and may be omitted if desired.

- ❑ 3. Slide the three aluminum fuel tubes into the rubber stopper.

- ❑ 4. Cut the fill line and carb line tubes such that the tubes extend 1/2" [13 mm] out from both ends of the stopper. The vent line should be bent upwards and left uncut.

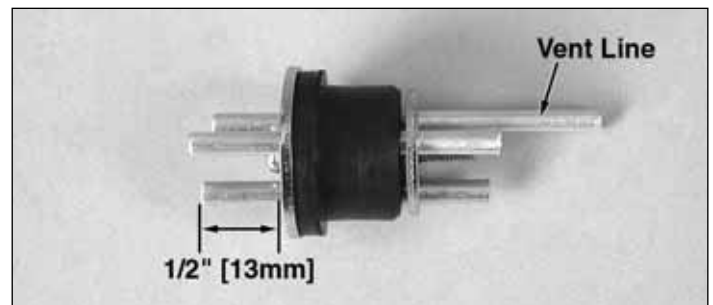

- ❑ 5. Install the metal plates on the front and back of the stopper and loosely thread the 3 x 26mm [1"] Phillips screw through the plates.

- ❑ 6. Attach a silicone fuel line 6" [153 mm] in length to the carb tube on the stopper. Install the included fuel clunk onto this line. If you want to have the ability to drain the fuel tank through the fill line, install another piece of silicone fuel line and a fuel clunk onto the fill line.

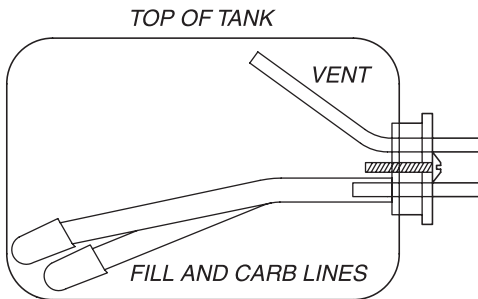

7. Insert the stopper into the tank and check the length of the carb line and fill lines. The clunks should rest almost against the back of the tank when the stopper is in place but move freely. Adjust the length of the fuel line until the proper length has been reached. Once you are satisfied with the fit, secure the stopper using the Phillips head screw in the stopper assembly. Be careful not to overtighten as the fuel tank could split.

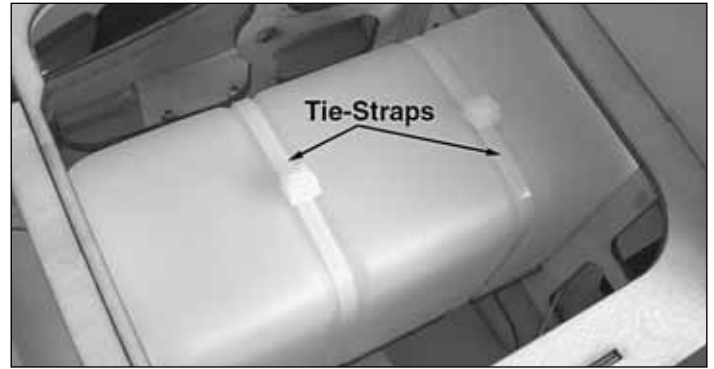

10. Secure the fuel tank to the mounting tray using the included tie-straps. Align the grooves in the tank with the grooves cut out of the sides of the mounting tray. Fit the tie-straps around these grooves.



8. Cut a piece of 1/4" [6.4 mm] foam rubber (not included) to fit the fuel tank mounting tray. Glue it in place using CA. Temporarily insert the fuel tank into the fuselage as shown.

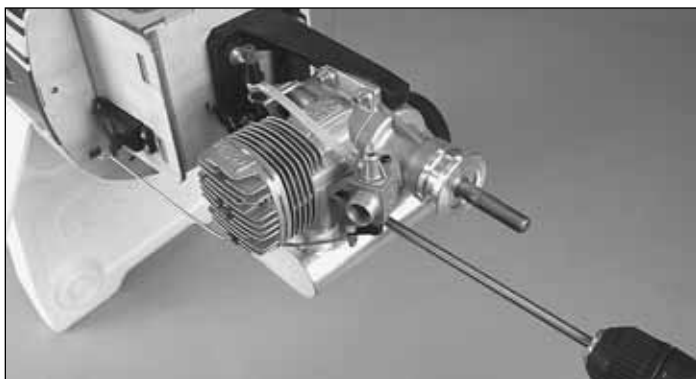

9. Drill a hole through the firewall for the carburetor fuel line to pass through. Use the position of the fuel tank lines and the fuel inlet on the carburetor to locate the hole. An extended drill bit can be used, or mark where the hole is to be drilled and remove the engine from the mount to use a standard length drill bit. Drill another hole (if you equipped your fuel tank with a fill line) on the underside of the engine mounting box for the fill line. The vent line can also be routed out the underside of the mounting box.

Optional Gas Engine Installation

Note: The fuel line and stopper included in the Great Planes Yak 54 1.60 ARF are NOT gasoline safe. Gasoline will degrade the rubber stopper and silicone fuel tubing supplied. You will need to purchase a gasoline safe stopper and gasoline safe tubing to use for the fuel system on this model. The **Sullivan #484 Gasoline/Diesel fuel tank conversion kit (SULQ2684)** works well for this. See the **"Fuel Tank Setup"** section on page 3.

A mounting template for the Fuji-Imvac BT-43 EI engine is provided on the back cover page of this manual and pictures taken show the installation of this model gas engine. If another model engine is used, the engine manufacturer may provide a mounting template to use on the firewall. The gas engine installation will be similar for most model engines.

Because of the possibility of ignition engines creating radio noise, we use a plastic pushrod for the throttle servo installation. This isolates the engine and any radio noise from the servos. This is an IMPORTANT selection, and we cannot recommend strongly enough that you DO NOT change this pushrod to a metal pushrod. All radio equipment – including throttle servo, receiver battery, electronic kill switch, receiver on/off switch, servo leads – should be mounted at least 10" [250 mm] away from anything related to the ignition/gasoline engine. Any material used between the engine and the radio equipment is STRONGLY recommended to be plastic, nylon, or otherwise non-metallic and nonconductive to minimize ignition noise transmission.

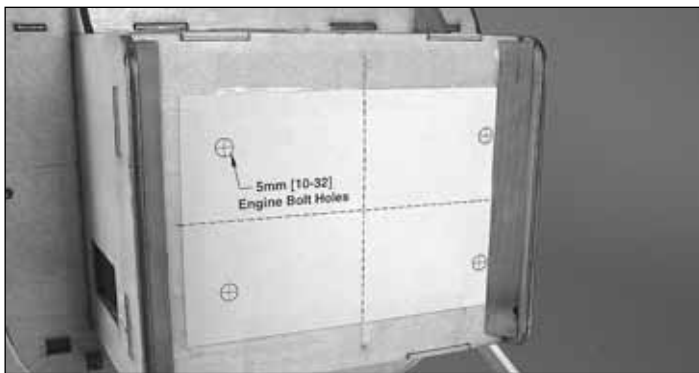

❑ 1. Cut the mounting bolt template for the Fuji-Imvac BT-43 EI Gas Engine from the rear of this manual and tape it to the firewall. Align the vertical and horizontal lines as shown.

❑ 2. Mark the hole centers with a pin and drill 3/32" [2.5 mm] pilot holes at the cross marks for the bolt holes.

❑ 3. Remove the template and enlarge the holes using a 1/4" [6 mm] drill bit.

❑ 4. Install 10-32 blind nuts (not included) into the rear of the firewall using epoxy. Thread a 10-32 bolt with a washer into each blind nut to draw them tight against the firewall.

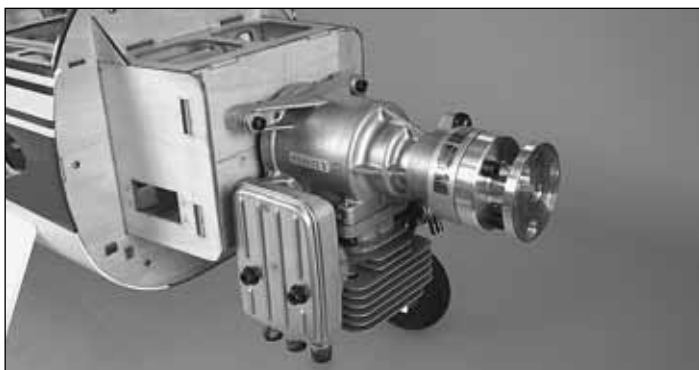

❑ 5. Mount the engine inverted to the firewall using 10-32 x 1-1/4" [32 mm] bolts, #10 flat washers and #10 lock washers (not included). If the neck of the blind nuts you are using protrude from the front of the firewall, install #10 washers (not included) in between the engine and firewall over the blind nuts. The face of the prop hub will be approximately 6-3/4" [171 mm] when installing the Fuji-Imvac BT-43 EI engine. Other brand engines may vary slightly in length. The acceptable range is 6-3/4" to 7-1/4" [171 to 184 mm] (this distance will automatically be adjusted for when using the cowl ring).

❑ 6. Mount the ignition unit and gas ignition kill switch following the guidelines from the shaded box on the bottom right-hand column on page 21 and following your engine manufacturer's instructions. There is space available behind the firewall.

❑ 7. Remove the stopper from the included fuel tank and replace it with a gas safe stopper as mentioned above.



❑ 8. Assemble the stopper using Du-Bro #813 1/8" [3.2 mm] I.D. fuel line barbs and 1/8" [3.2 mm] brass tubing as shown. Solder the barbs to the brass tubing but be careful not to overheat the assembly as it could cause damage to the rubber stopper. See the **Expert Tip** that follows.

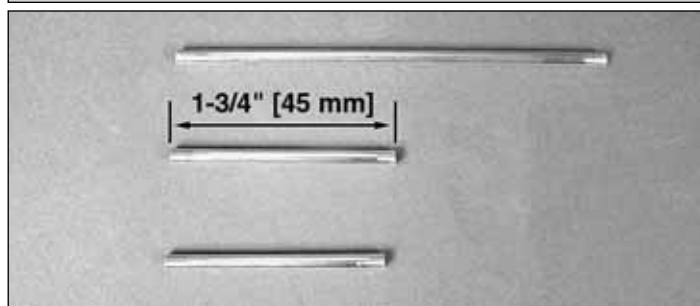

A. Cut one of the two brass tubes included with the Sullivan conversion kit in half (approximately 1-3/4" [45 mm] pieces). Prepare the tubes for solder by scuffing up the ends with sandpaper and cleaning them with alcohol.

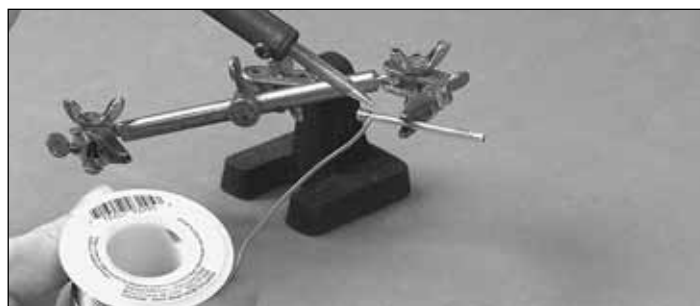

B. Solder a Du-Bro fuel line barb onto one end of each of the three tubes (be sure that the barbs are positioned on the tubes so that they will secure the fuel tubing when fitted in place). Slide the barbs in place and apply a small amount of solder to the joints between the barbs and the tubes. Solder will wick into the joints securing them in place. Be careful not to use too much solder as it could obstruct fuel flow inside the tubes.

Note: The item used in the picture above to hold the tubes is the X-Acto Extra Hands Double Clip (XACR4214).



C. Assemble the stopper by inserting the tubes through the large stopper plate, stopper, and then the small stopper plate. Join the plates and stopper together using the screw that came with the conversion kit.

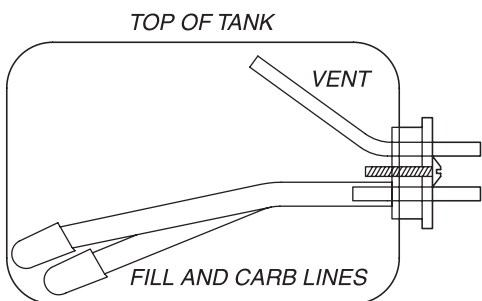

❑ 9. Attach gasoline safe fuel line with clunks to the tubing as shown; remember to bend the vent line upwards towards the top of the fuel tank. The clunks should move freely, but rest almost against the back of the tank when the tank is held vertical.

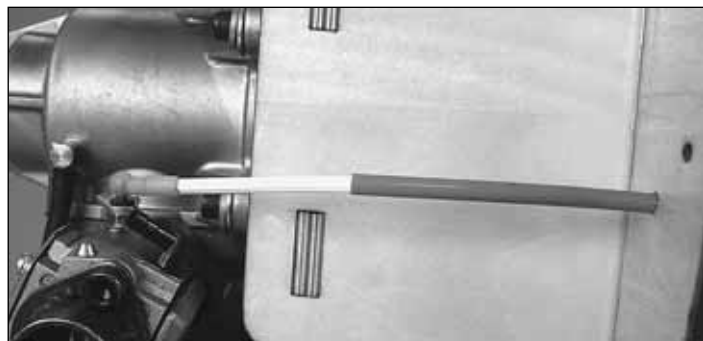
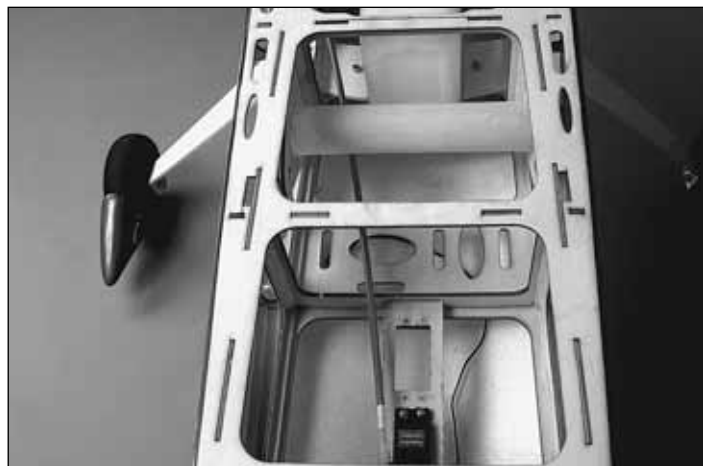

❑ 2. Using a non-metallic flexible pushrod system (not included), connect the throttle servo to the carburetor on your engine. The Great Planes Semi-Flexible Pushrod System (GPMQ3714) would work well in this application. Since engine installations can vary, the location of the holes in the formers and firewall for the pushrod to route through will also vary. Use the photos as a guide for the installation. Temporarily install the wing panels and be sure that the pushrod does not interfere with fully seating the wing panels into the fuselage.

Install the Throttle Servo (Gas Engine)



❑ 1. Install the throttle servo into one of the open servo bays in the center of the fuselage. An additional throttle servo tray is provided in case the throttle cable being used will not work with a center mounted servo. The tray can be glued to the side of the center servo bays, or trimmed and mounted elsewhere inside the fuselage.

Prepare the Cowl

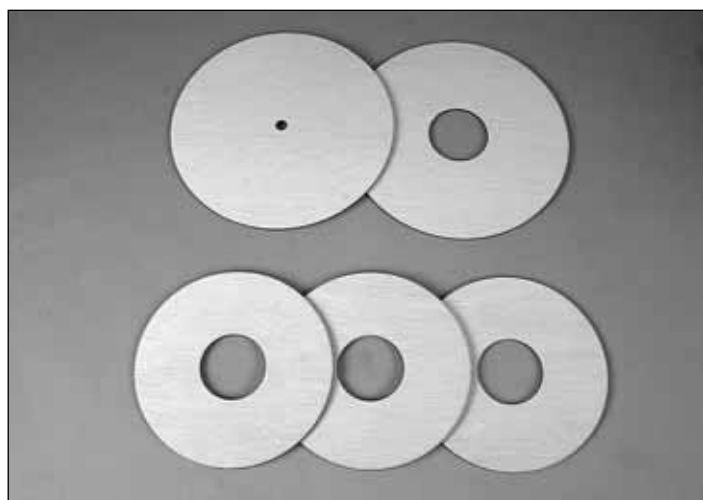

❑ 1. Locate the five cowl rings that match the engine you will be installing into the Yak 54 1.60 ARF. Other model engines besides the O.S. 1.60 FX and Fuji-Imvac BT-43 EI can still use the rings; however, modification to the holes for the drive

washer and prop shaft may be required and it is up to the modeler to do so. We suggest reading through the entire cowl preparation section before building the cowl ring so you understand how it works and will be able to modify the ring if necessary while assembling it to match your engine.



❑ 2. Glue the three smaller rings together, being careful to align them flush. Test fit this assembly into the front of the **cowl**. It should be able to pass through the opening. If not, sand the edges until it can.

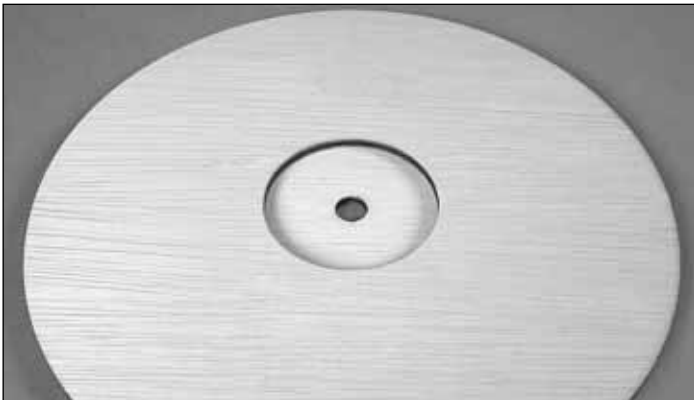

❑ 3. Glue the two larger rings together, being careful to align them flush. Note that one large ring has a small hole in the center, and the other large ring has a large hole in the center.



❑ 4. Glue the two cowl ring assemblies together with the center holes all flush. Be sure that the large ring with the small hole in the center is at the bottom.

❑ 5. Test fit the **cowl ring** onto the firewall to determine its correct orientation. The holes in the cowl ring will only line up with the holes in the firewall one way.

❑ 6. Sand the inside perimeter of the cowl approximately 1" [25 mm] from the aft end to prepare it for glue. Clean the sanded area with compressed air and wipe it down with denatured alcohol.

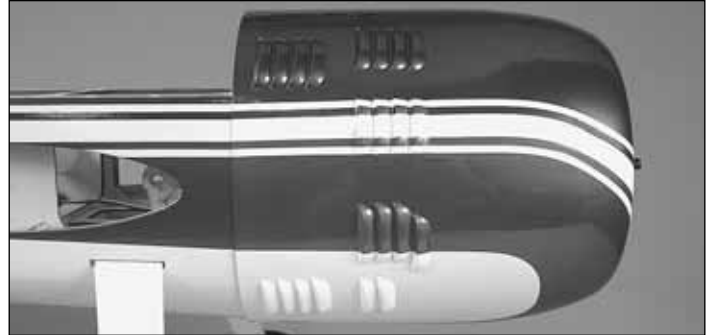

❑ 7. Temporarily secure the cowl ring to the firewall using a few 4-40 x 1/2" [13 mm] socket head cap screws. Slide the cowl over the cowl ring, aligning the colors on the cowl with the colors on the fuselage. Overlap the fuselage with the cowl by 1/4" [6 mm]. This step has positioned the cowl ring inside the cowl so the colors will align when the cowl is permanently glued to the cowl ring.



❑ 8. Use the included cowl ring to accurately set the depth and angle of the cowl so that it is centered over the spinner. The ring fits onto the engine crankshaft with the round recess fitting over the engine drive washer as shown. Slide the ring onto the crankshaft until it touches the front of the cowl. While maintaining even pressure around the ring, use it to push the

cowl back until the ring is fully seated on the drive washer. (Some engine installations may require you to cut a portion of the cowl away to clear the engine head in order to fit it onto the fuselage. Cut away just enough needed to fit the cowl now. A clean-edged, straight, cooling hole can be more carefully cut out when finishing the model).



Make Your Own Extra-Long Hex Wrench

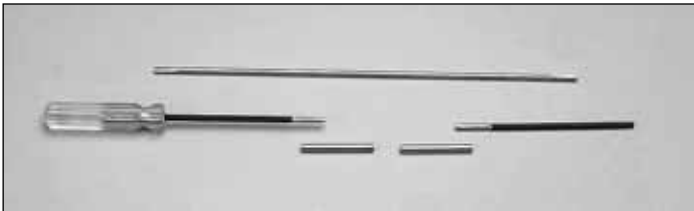

An extra-long 3/32" [2.4 mm] allen wrench is included with the Yak 54 1.60 ARF to install and remove the cowl screws. If you would like to make an extended wrench with a handle rather than the one supplied with an "L"-bend, one could be made by splicing together a 3/32" [2.4 mm] ball-end hex wrench with a piece of 4-40 pushrod and 1/8" [3.2 mm] brass tubing. Use a file to round the ends of the wrench so they will fit into the brass tubes. Then, hold it all together with silver solder.

The wrench can be made to any length you like, and is so useful that it will probably become a permanent addition to the field box.

9. Carefully remove the cowl ring from the engine crankshaft being sure not to disturb the position of the cowl (masking tape will help hold the cowl in position). Temporarily secure the cowl ring to the cowl with a couple of dots of 6-minute epoxy. Using the included extra long 3/32" [2.4 mm] allen key, remove the 4-40 x 1/2" [13 mm] cap head screws securing the cowl ring to the firewall. Slide the cowl and cowl ring off of the fuselage as one piece. The friction fit between the ring, cowl and the epoxy will hold them together.

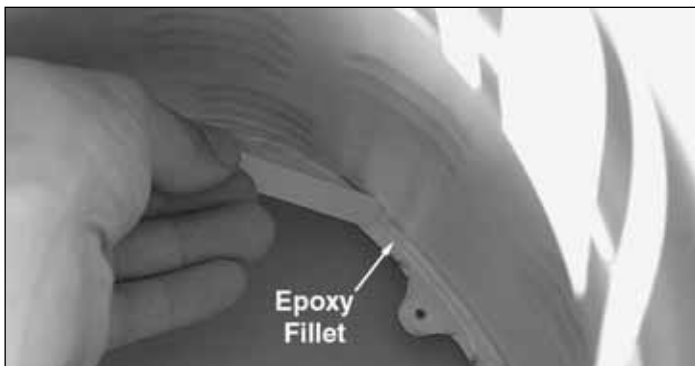

10. Mix up 1/2 oz. [15 cc] batch of 30-minute epoxy combined with Top Flite Microballoons Filler (if using a gas engine, substitute Microballoons Filler with Great Planes

Pro Milled Fiberglass for a stronger joint and make a larger fillet as described in this step). Make an epoxy fillet along the front of the cowl ring where it meets the cowl. Do not apply epoxy to the back of the cowl ring as it will interfere with the ring sitting flush against the firewall. Let the cowl sit undisturbed until the epoxy has cured.

FINISH THE MODEL

Install the Radio System

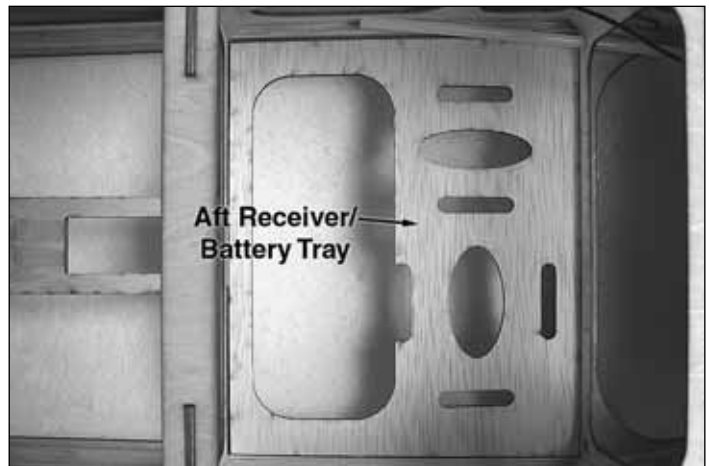

Note: The Yak 54 1.60 ARF includes an optional **aft receiver/battery tray**. This tray can be used if the model requires excessive weight added to the tail in order to balance within the range specified in the balance section of this manual. Heavier gas engines will most likely result in required tail weight. If tail weight is required, fit the optional aft receiver/battery tray into the fuselage as shown and glue it in place. Move your radio equipment to the aft tray and rebalance the model. The servo extensions mentioned earlier are long enough to reach the aft receiver/battery installation.



1. Install your receiver switch or an optional switch mounting jack (we used the Great Planes Switch/Charge Jack Mounting Set, GPMM1000) in a position on the fuselage so the battery and charge leads are within reach of the receiver tray.

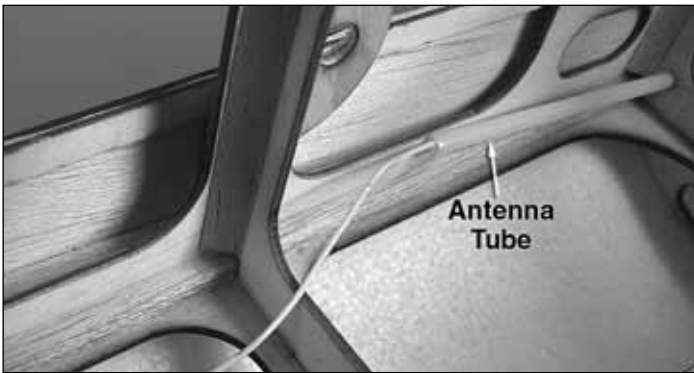
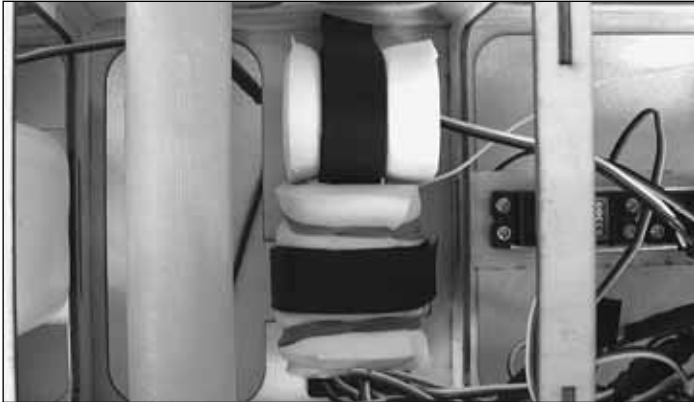

❑ 2. Connect the rudder servos, elevator servos, and throttle servo (if using a radio system that does not support mixing, install Y-harnesses to the servos) to the receiver and wrap it in 1/4" [6 mm] foam rubber. Also wrap the receiver battery in foam rubber. Cut the included hook and loop material into two equal lengths and use it to secure the receiver and battery to the tray as shown (the same instructions apply if using the optional aft receiver/battery tray). Feed the receiver antenna through the plastic antenna tube installed on the right side of the fuse.

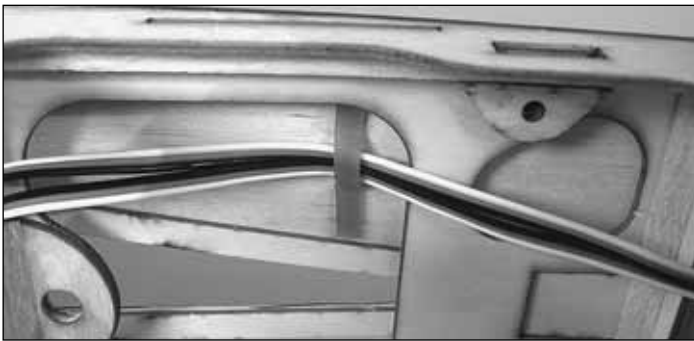

❑ 3. At this point, the servo wires should be organized and secured out of the way of the rudder pull-pull cables if using the pull-pull system. One easy way to do this is to cut a few #64 rubber bands into 3/4" to 1" [19 to 25 mm] long pieces and use them as wire straps by gluing them to the side of the fuselage with CA glue. For best adhesion, roughen the area with sandpaper before applying CA.

Install the Cowl



❑ 1. Hold the cowl up to the firewall and mark where you will be cutting out a cooling hole (exhaust exit hole). If installing a glow engine, you will also want to mark the position for a glow starter hole and a needle valve hole.

❑ 2. Use a rotary cutting tool to cut the cooling hole and a drill for the other holes you have marked. For a clean, finished look, use a bar sander with 220-grit sandpaper to clean up straight cuts, and sand the curved or round cuts by hand. Test fit the cowl onto the fuselage and make any other adjustments necessary to clear engine components.



❑ 3. Install the cowl with the long 3/32" [2.4 mm] allen key using six 4-40 x 1/2" [13 mm] SHCS, six #4 flat washers, and six #4 lock washers.

Install the Spinner

O.S. Max 1.60 FX



❑ 1. Slide the spinner backplate onto the crankshaft. Ream the propeller as necessary to fit the engine and push it onto the crankshaft (don't forget to balance your prop!). Install the prop washer and mating jam nut onto the crankshaft and properly tighten the nut.



❑ 2. Tighten the spinner adapter against the prop nut.



❑ 3. Secure the spinner to the adapter with the 5 x 55mm [3/16" x 2-5/32"] spinner screw. If the screw is too long, use a cutoff tool such as a Dremel rotary tool to shorten the screw. Thread the included 5mm [3/16"] nut onto the spinner screw before cutting. When the nut is removed, it will straighten the threads on the screw that may have been deformed from the cutting process.

Note: The procedure for attaching the spinner to a Fuji-Imvac BT-43 EI engine is the same as the 1.60 FX. However, you will use the spinner bolt included with the engine instead of the spinner adapter shown above. There is a longer 70mm [2-3/4"] spinner screw provided for use with gas engines.

Attach the Wing & Canopy

❑ 1. Slide the aluminum wing tube into the fuselage.

❑ 2. Push the wing panels into position, feeding the aileron servo extensions through the holes in the fuselage.



❑ 3. Use the included nylon wing bolts to tighten the wing panels to the fuselage. Be sure that the root ribs in the wings are flat against the fuselage sides.



❑ 4. Locate the four holes beneath the covering for the canopy mounting bolts. Use a sharp hobby knife to trim the covering from the holes.

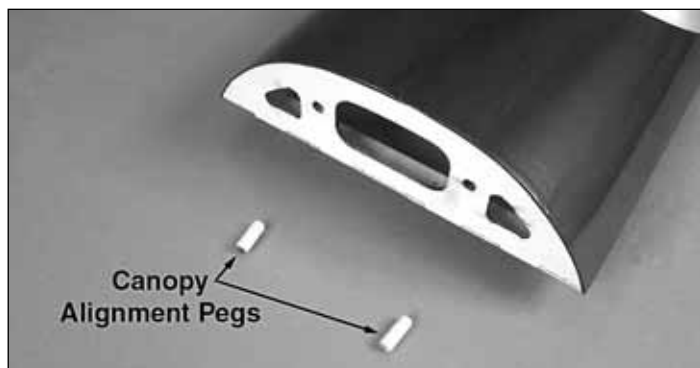

❑ 5. Bevel the ends of the **canopy alignment pegs** with sandpaper. Confirm that they will fit into the two holes in the front of the **canopy**.

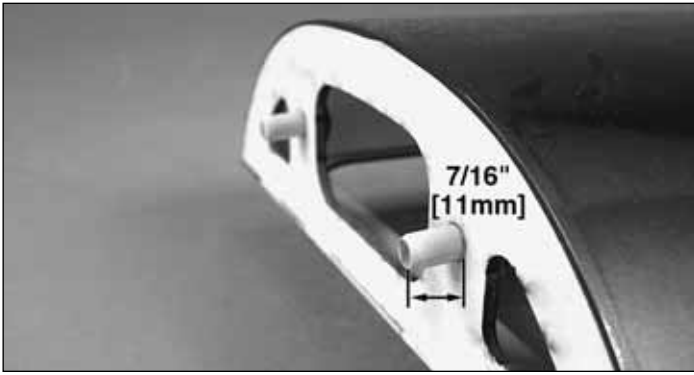

❑ 6. Use epoxy to glue the pegs into the canopy, leaving 7/16" [11 mm] protruding from the front.

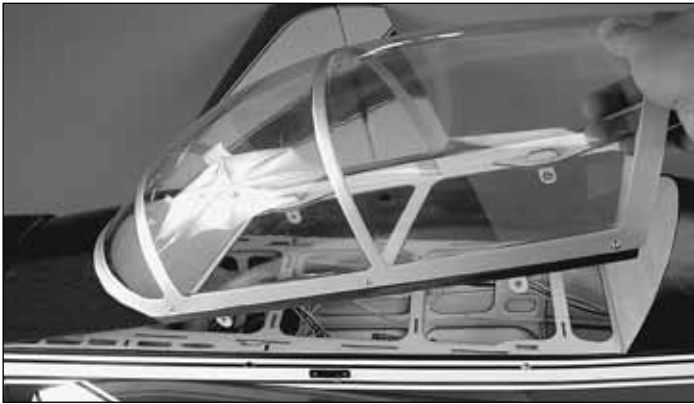

❑ 7. Tilt the canopy in place by inserting the alignment pegs into their mating holes in the fuselage and pushing the mounting tabs in back into the mating slots on the sides of the fuselage. If the canopy is difficult to install, sand a bit of material away from the pegs a little at a time until the canopy fully seats onto the fuse.



❑ 8. Secure the canopy to the fuselage using four 4-40 x 1" [25 mm] SHCS and four #4 flat washers. We suggest using medium CA to glue the washers to the screws. This will prevent the washers from falling into the fuselage when the screws are removed.

❑ 9. The lexan canopy needs to be glued to the canopy frame. If you choose to, now is the time to paint the inside of the cockpit, install the instrument panel decal, install the included canopy floor and headrest. You can also install the pilot figure of your choice (not included). After you have completed detailing the cockpit, glue the lexan canopy to the canopy frame using canopy glue such as Pacer Formula 560 canopy glue (PAAR3300). Reinstall the six canopy screws.

Apply the Decals

1. Use scissors or a sharp hobby knife to cut the decals from the sheet.

2. Be certain the model is clean and free from oily fingerprints and dust. Prepare a dishpan or small bucket with a mixture of liquid dish soap and warm water—about one teaspoon of soap per gallon of water. Submerge the decal in the soap and water and peel off the paper backing. **Note:** Even though the decals have a "sticky-back" and are not the water transfer type, submersing them in soap and water allows accurate positioning and reduces air bubbles underneath.

3. Position decal on the model where desired. Holding the decal down, use a paper towel to wipe most of the water away.

4. Use a piece of soft balsa or something similar to squeegee remaining water from under the decal. Apply the rest of the decals the same way.

GET THE MODEL READY TO FLY

Check the Control Directions

❑ 1. Turn on the transmitter and receiver and center the trims. If necessary, remove the servo arms from the servos and reposition them so they are centered. Reinstall the screws that hold on the servo arms.

❑ 2. With the transmitter and receiver still on, check all the control surfaces to see if they are centered. If necessary, adjust the clevises on the pushrods to center the control surfaces.

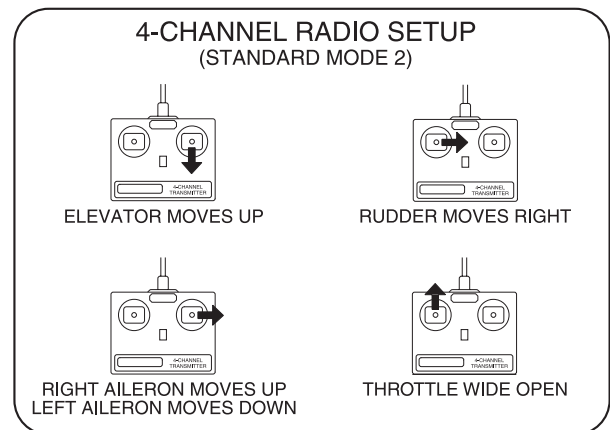

❑ 3. Make certain that the control surfaces and the carburetor respond in the correct direction as shown in the diagram. If any of the controls respond in the wrong direction, use the servo reversing in the transmitter to reverse the servos connected to those controls. Be certain the control surfaces have remained centered. Adjust if necessary.

Set the Control Throws

Due to the size of the control surfaces on the GP Yak 54 1.60 ARF, use of a Great Planes AccuThrow™ is not possible for measuring throws. A ruler should be used to accurately measure and set the control throw of each control surface as indicated in the chart that follows.

Note: The throws are measured at the **widest part** of the elevators, rudder and ailerons.

These are the recommended control surface throws:

	High Rate	Low Rate
ELEVATOR:	1-1/4" [32 mm] up 1-1/4" [32 mm] down	7/8" [22 mm] up 7/8" [22 mm] down
RUDDER:	2-1/2" [64 mm] right 2-1/2" [64 mm] left	1" [25 mm] right 1" [25 mm] left
AILERONS:	1" [25 mm] up 1" [25 mm] down	7/8" [22 mm] up 7/8" [22 mm] down

3D RATES

3D ELEVATOR: 2-1/2" [64 mm] up
2-1/2" [64 mm] down

3D RUDDER: 4" [102 mm] right
4" [102 mm] left

3D AILERONS: 2-1/4" [57 mm] up
2-1/4" [57 mm] down

IMPORTANT: The Yak 54 1.60 ARF has been **extensively** flown and tested to arrive at the throws at which it flies best. Flying your model at these throws will provide you with the greatest chance for successful first flights. If, after you have become accustomed to the way the Yak 54 1.60 ARF flies, you would like to change the throws to suit your taste, that is fine. However, too much control throw could make the model difficult to control, so remember, "more is not always better." In order to achieve the full 3D rates noted in the chart above, you will need to purchase longer servo arms. Refer to the "**Optional Supplies & Tools**" section on page 4 for part numbers.

Balance the Model (G.G.)

More than any other factor, the **C.G.** (balance point) can have the **greatest** effect on how a model flies, and may determine whether or not your first flight will be successful. If you value this model and wish to enjoy it for many flights, **DO NOT OVERLOOK THIS IMPORTANT PROCEDURE.** A model that is not properly balanced will be unstable and possibly unflyable.

At this stage the model should be in ready-to-fly condition with all of the systems in place, including the engine, landing gear, and the radio system.

❑ 1. Use a felt-tip pen or 1/8" [3 mm]-wide tape to accurately mark the C.G. on the top of the wing on both sides of the fuselage. The C.G. is located 5-1/8" [130 mm] back from the leading edge of the wing at the fuselage.

This is where your model should balance for the first flights. Later, you may wish to experiment by shifting the C.G. up to 1/2" [13 mm] forward or 1/2" [13 mm] back to change the flying characteristics. Moving the C.G. forward may improve the smoothness and stability, but the model may then require more speed for takeoff and make it more difficult to slow for landing. Moving the C.G. aft makes the model more maneuverable, but could also cause it to become too difficult to control. In any case, **start at the recommended balance point** and do not at any time balance the model outside the specified range.

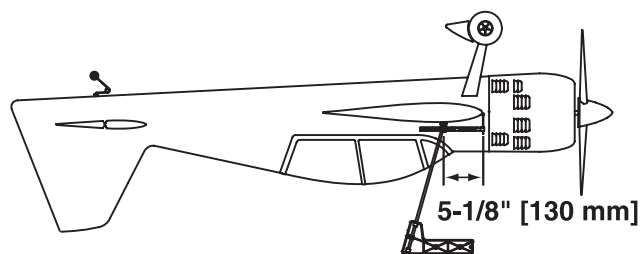

❑ 2. With the wing attached to the fuselage, all parts of the model installed (ready to fly) and an empty fuel tank, place the model upside-down on a Great Planes CG Machine, or lift it upside-down at the balance point you marked.

❑ 3. If the tail drops, the model is "tail heavy" and the battery pack and/or receiver must be shifted forward or weight must be added to the nose to balance. If the nose drops, the model is "nose heavy" and the battery pack and/or receiver must be shifted aft or weight must be added to the tail to balance. If possible, relocate the battery pack and receiver to minimize or eliminate any additional ballast required. If additional weight is required, nose weight may be easily added by using a "spinner weight" (GPMQ4645 for the 1 oz.

[28 g] weight, or GPMQ4646 for the 2 oz. [57 g] weight). If spinner weight is not practical or is not enough, use Great Planes (GPMQ4485) “stick-on” lead. A good place to add stick-on nose weight is to the firewall (don’t attach weight to the cowl—it is not intended to support weight). Begin by placing incrementally increasing amounts of weight on the bottom of the fuse over the firewall until the model balances. Once you have determined the amount of weight required, it can be permanently attached. If required, tail weight may be added by cutting open the bottom of the fuse and gluing it permanently inside.

Note: Do not rely upon the adhesive on the back of the lead weight to permanently hold it in place. Over time, fuel and exhaust residue may soften the adhesive and cause the weight to fall off. Use #2 sheet metal screws, RTV silicone or epoxy to permanently hold the weight in place.

4. **IMPORTANT:** If you found it necessary to add any weight, recheck the C.G. after the weight has been installed.

Balance the Model Laterally

1. With the wing level, have an assistant help you lift the model by the engine propeller shaft and the bottom of the fuse under the TE of the fin. Do this several times.

2. If one wing always drops when you lift the model, it means that side is heavy. Balance the airplane by adding weight to the other wing tip. **An airplane that has been laterally balanced will track better in loops and other maneuvers.**

PREFLIGHT

Identify Your Model

No matter if you fly at an AMA sanctioned R/C club site or if you fly somewhere on your own, you should always have your name, address, telephone number and AMA number on or inside your model. It is **required** at all AMA R/C club flying sites and AMA sanctioned flying events. Fill out the identification tag on page 35 and place it on or inside your model.

Charge the Batteries

Follow the battery charging instructions that came with your radio control system to charge the batteries. You should always charge your transmitter and receiver batteries the night before you go flying, and at other times as recommended by the radio manufacturer.

CAUTION: Unless the instructions that came with your radio system state differently, the **initial** charge on **new** transmitter and receiver batteries should be done for 15 hours **using the slow-charger that came with the radio system.** This will “condition” the batteries so that the next charge may be done using the fast-charger of your choice. If the initial charge is done with a fast-charger the batteries may not reach their full capacity and you may be flying with batteries that are only partially charged.

Balance the Propellers

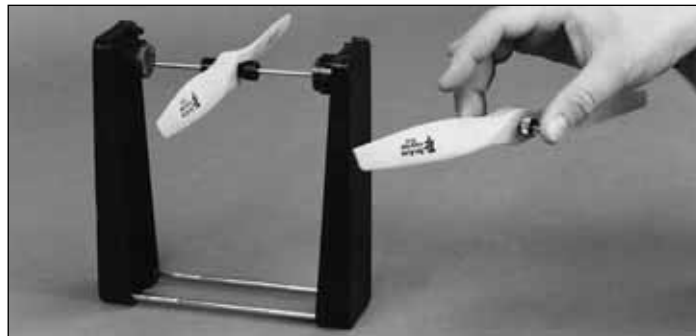

Carefully balance your propeller and spare propellers before you fly. An unbalanced prop can be the single most significant cause of vibration that can damage your model. Not only will engine mounting screws and bolts loosen, possibly with disastrous effect, but vibration may also damage your radio receiver and battery. Vibration can also cause your fuel to foam, which will, in turn, cause your engine to run hot or quit.

We use a Top Flite Precision Magnetic Prop Balancer™ (TOPQ5700) in the workshop and keep a Great Planes Fingertip Prop Balancer (GPMQ5000) in our flight box.

Ground Check

If the engine is new, follow the engine manufacturer's instructions to break-in the engine. After break-in, confirm that the engine idles reliably, transitions smoothly and rapidly to full power and maintains full power—indefinitely. After you run the engine on the model, inspect the model closely to make sure all screws remained tight, the hinges are secure, the prop is secure and all pushrods and connectors are secure.

Range Check

Ground check the operational range of your radio before the first flight of the day. With the transmitter antenna collapsed and the receiver and transmitter on, you should be able to walk at least 100 feet away from the model and still have control. Have an assistant stand by your model and, while you work the controls, tell you what the control surfaces are doing. Repeat this test with the engine running at various

speeds with an assistant holding the model, using hand signals to show you what is happening. If the control surfaces do not respond correctly, do not fly! Find and correct the problem first. Look for loose servo connections or broken wires, corroded wires on old servo connectors, poor solder joints in your battery pack or a defective cell, or a damaged receiver crystal from a previous crash.

ENGINE SAFETY PRECAUTIONS

Failure to follow these safety precautions may result in severe injury to yourself and others.

Keep all engine fuel in a safe place, away from high heat, sparks or flames, as fuel is very flammable. Do not smoke near the engine or fuel; and remember that engine exhaust gives off a great deal of deadly carbon monoxide. Therefore, do not run the engine in a closed room or garage.

Get help from an experienced pilot when learning to operate engines.

Use safety glasses when starting or running engines.

Do not run the engine in an area of loose gravel or sand; the propeller may throw such material in your face or eyes.

Keep your face and body as well as all spectators away from the plane of rotation of the propeller as you start and run the engine.

Keep these items away from the prop: loose clothing, shirt sleeves, ties, scarves, long hair or loose objects such as pencils or screwdrivers that may fall out of shirt or jacket s into the prop.

Use a "chicken stick" or electric starter to start the engine. Do not use your fingers to flip the propeller. Make certain the glow plug clip or connector is secure so that it will not pop off or otherwise get into the running propeller.

Make all engine adjustments from behind the rotating propeller.

The engine gets hot! Do not touch it during or right after operation. Make sure fuel lines are in good condition so fuel will not leak onto a hot engine, causing a fire.

To stop a glow engine, cut off the fuel supply by closing off the fuel line or following the engine manufacturer's recommendations. Do not use hands, fingers or any other body part to try to stop the engine. To stop a gasoline powered engine an on/off switch should be connected to the engine coil. Do not throw anything into the propeller of a running engine.

AMA SAFETY CODE (excerpts)

Read and abide by the following excerpts from the Academy of Model Aeronautics Safety Code. For the complete Safety Code refer to *Model Aviation* magazine, the AMA web site or the Code that came with your AMA license.

General

- 1) I will not fly my model aircraft in sanctioned events, air shows, or model flying demonstrations until it has been proven to be airworthy by having been previously, successfully flight tested.
- 2) I will not fly my model aircraft higher than approximately 400 feet within 3 miles of an airport without notifying the airport operator. I will give right-of-way and avoid flying in the proximity of full-scale aircraft. Where necessary, an observer shall be utilized to supervise flying to avoid having models fly in the proximity of full-scale aircraft.
- 3) Where established, I will abide by the safety rules for the flying site I use, and I will not willfully and deliberately fly my models in a careless, reckless and/or dangerous manner.
- 5) I will not fly my model unless it is identified with my name and address or AMA number, on or in the model. **Note:** This does not apply to models while being flown indoors.
- 7) I will not operate models with pyrotechnics (any device that explodes, burns, or propels a projectile of any kind).

Radio Control

- 1) I will have completed a successful radio equipment ground check before the first flight of a new or repaired model.
- 2) I will not fly my model aircraft in the presence of spectators until I become a qualified flier, unless assisted by an experienced helper.
- 3) At all flying sites a straight or curved line(s) must be established in front of which all flying takes place with the other side for spectators. Only personnel involved with flying the aircraft are allowed at or in the front of the flight line. Intentional flying behind the flight line is prohibited.
- 4) I will operate my model using only radio control frequencies currently allowed by the Federal Communications Commission.
- 5) **I will not knowingly operate my model within three miles of any pre-existing flying site except in accordance with the frequency sharing agreement listed** [in the complete AMA Safety Code].
- 9) Under no circumstances may a pilot or other person touch a powered model in flight; **nor should any part of the model other than the landing gear, intentionally touch the ground, except while landing.**

IMAA SAFETY CODE (excerpts)

Since the Yak 54 1.60 ARF qualifies as a “giant-scale” model and is therefore eligible to fly in IMAA events, we’ve printed excerpts from the IMAA Safety Code which follows.

What is Giant-Scale?

The concept of large or giant-scale is generally considered to apply to radio controlled model aircraft with minimum wingspans of 80 inches for monoplanes and 60 inches for multi-wing aircraft. Quarter-scale or larger replicas of person-carrying aircraft with proper documentation (minimum 3-view drawing) which do not fit the size requirements will also be permitted.

SECTION 1.0: SAFETY STANDARD

1.1 – Adherence to Code: The purpose of this Safety Code is to provide a structure whereby all participants, including spectators, will be aware of the inherent dangers in the operation of radio controlled aircraft. This code is meant to serve as a minimum guideline to all participants. It is understood that the ultimate responsibility for the safety of any aircraft lies with the owner(s), pilot(s) and spectator(s) involved in any event. It is the responsibility of all participants to exercise caution when operating, or observing the operation of all radio controlled aircraft. The pilot/owner of an aircraft will not be dissuaded from taking whatever steps they deem necessary, in addition to this code, to insure that their aircraft is safe.

1.2 – The most current AMA Safety Code in effect is to be observed.

SECTION 3.0: SAFETY REVIEW

3.4 – Flight Testing: All aircraft are to have been flight tested and flight trimmed with a minimum of six (6) flights before the model is allowed to fly at an IMAA Sanctioned event.

3.5 – Proof of Flight: The completing and signing of the Declaration section of the Safety Review form (see Section 3.2) by the pilot (or owner) shall document, as fact, that the noted aircraft has been successfully flight tested and proven airworthy prior to the IMAA event.

SECTION 4.0: SPOTTER/HELPER

4.1 – Spotter/Helper Definition: An assistant to aid the pilot during start-up, and taxiing onto the runway. The spotter/helper will assist the pilot in completing a safe flight.

4.2 – Each pilot is required to have a spotter/helper at all IMAA sanctioned events. The event Safety Committee should be prepared to assist those pilots who do not have a spotter/helper to make sure that every registered pilot has the opportunity to fly at a sanctioned event.

SECTION 5.0: EMERGENCY ENGINE SHUT OFF (Kill Switch)

5.1 – Magneto spark ignition engines must have a coil-grounding switch on the aircraft to stop the engine. This will also prevent accidental starting of the engine. This switch shall be readily available to both pilot and spotter/helper. This switch is to be operated manually and without the use of the Radio System.

5.2 – Engines with battery powered ignition systems must have a switch to turn off the power from the battery pack to disable the engine from firing. This will also prevent accidental starting of the engine. This switch shall be readily available to both pilot and spotter/helper. This switch shall be operated manually and without the use of the Radio System.

5.3 – There must also be a means to stop the engine from the transmitter. The most common method is to completely close the carburetor throat using throttle trim; however, other methods are acceptable. This requirement applies to all glow/gas ignition engines regardless of size.

SECTION 6.0: RADIO REQUIREMENTS

6.1 – All transmitters must be FCC type certified.

6.2 – FCC Technician or higher-class license required for 6 meter band operation only.

ADDITIONAL IMAA GENERAL RECOMMENDATIONS

The following recommendations are included in the Safety Code not to police such items, but rather to offer basic suggestions for enhanced safety. It is expected that IMAA members will avail themselves of technological advances as such become available, to promote the safety of all aircraft and participants.

Servos need to be of a rating capable to handle the loads that the control surfaces impose upon the servos. Standard servos are not recommended for control surfaces. Servos should be rated heavy-duty. For flight-critical control functions a minimum of 45 inch/ounces of torque should be considered. This should be considered a minimum for smaller aircraft and higher torque servos are strongly encouraged for larger aircraft. The use of one servo for each aileron and one for each stabilizer half is strongly recommended. Use of dual servos is also recommended on larger aircraft.

On-board batteries should be, at a minimum, 1000mAh up to 20 lbs., 1200mAh to 30 lbs., 1800mAh to 40 lbs., and 2000mAh over 40 lbs. flying weight. The number and size of servos, size and loads on control surfaces, and added features should be considered as an increase to these minimums. Batteries should be able to sustain power to the onboard radio components for a minimum of one hour total flying time before recharging.

Dependable, redundant and fail-safe battery systems are recommended.

The use of anti-glitch devices for long leads is recommended.

There is no maximum engine displacement limit, as it is the position of this body that an under powered aircraft presents a greater danger than an over powered aircraft. However, the selections of engine size relative to airframe strength and power loading mandates good discretionary judgment by the designer and builder. Current AMA maximums for engine displacement are 6.0 cu in for two-stroke and 9.6 cu in for four-stroke engines. These maximums apply only to AMA Sanction competition events (such as 511, 512, 515 and 520). All non competition events should be sanctioned as Class C events, in which these engine size maximums do not apply.

Generally, it is recommended that no attempt should be made to fly a radio controlled model aircraft with a gasoline engine in which the model aircraft weight would exceed 12 pounds per cubic inch of engine displacement (under powered), or be less than 5 pounds per cubic inch of engine displacement (overpowered). Example: Using a 3 cu in engine, a model would likely be under powered at an aircraft weight greater than 36 pounds. With the same engine, an aircraft weighing less than 15 pounds would likely be overpowered.

Servo arms and control horns should be rated heavy-duty. Glass-filled servo arms and control horns are highly recommended.

Control surface linkages are listed in order of preference:

1. Cable system (pull-pull). A tiller bar is highly recommended along with necessary bracing.
2. Arrow Shaft, fiberglass or aluminum, 1/4" or 5/16" OD. Bracing every six (6) to ten (10) inches is highly recommended.
3. Tube-in-tube (nyrod). Bracing every few inches is highly recommended. Inner tube should be totally enclosed in outer tube.
4. Hardwood dowel, 3/8" O.D. Bracing every six (6) to ten (10) inches is highly recommended.

Hinges should be rated heavy-duty and manufactured primarily for use in giant-scale aircraft. Homemade and original design hinges are acceptable if determined to be adequate for the intended use.

Clevis (steel, excluding heavy-duty ball links) and attachment hardware should be heavy-duty 4-40 threaded rod type. 2-56 threaded size rod is acceptable for some applications (e.g. throttle). Clevises must have lock nuts and sleeve (fuel tubing) or spring keepers.

Propeller tips should be painted or colored in a visible and contrasting manner to increase the visibility of the propeller tip arc.

CHECK LIST

During the last few moments of preparation your mind may be elsewhere anticipating the excitement of the first flight. Because of this, you may be more likely to overlook certain checks and procedures that should be performed before the model is flown. To help avoid this, a check list is provided to make sure these important areas are not overlooked. Many are covered in the instruction manual, so where appropriate, refer to the manual for complete instructions. Be sure to check the items off as they are completed.

- 1. Fuelproof all areas exposed to fuel or exhaust residue such as the cowl ring, cowl mounting blocks, wing saddle area, etc.
- 2. Check the C.G. according to the measurements provided in the manual.
- 3. Be certain the battery and receiver are securely mounted in the fuse. Simply stuffing them into place with foam rubber is not sufficient.
- 4. Extend your receiver antenna and make sure it has a strain relief inside the fuselage to keep tension off the solder joint inside the receiver.
- 5. Balance your model *laterally* as explained in the instructions.
- 6. Use thread-locking compound to secure critical fasteners such as the set screws that hold the wheel axles to the struts, screws that hold the carburetor arm (if applicable), screw-lock pushrod connectors, etc.
- 7. Add a drop of oil to the axles so the wheels will turn freely.
- 8. Make sure all hinges are **securely** glued in place.
- 9. Reinforce holes for wood screws with thin CA where appropriate (servo mounting screws, control horn screws, etc.).
- 10. Confirm that all controls operate in the correct direction and the throws are set up according to the manual.
- 11. Make sure there are silicone retainers on all the clevises and that all servo arms are secured to the servos with the screws included with your radio.
- 12. Secure connections between servo wires and Y-connectors or servo extensions, and the connection between your battery pack and the on/off switch with vinyl tape, heat-shrink tubing or special clips suitable for that purpose.
- 13. Make sure any servo extension cords you may have used do not interfere with other systems (servo arms, pushrods, etc.).
- 14. Secure the pressure tap (if used) to the muffler with high temp RTV silicone, thread-locking compound or J.B. Weld.
- 15. Make sure the fuel lines are connected and are not kinked.
- 16. Balance your propeller (and spare propellers).
- 17. Tighten the propeller nut and spinner.
- 18. Place your name, address, AMA number and telephone number on or inside your model.

- 19. Cycle your receiver battery pack (if necessary) and make sure it is fully charged.
- 20. If you wish to photograph your model, do so before your first flight.
- 21. Range check your radio when you get to the flying field.

FLYING

The Yak 54 1.60 ARF is a great-flying model that flies smoothly and predictably. The Yak 54 1.60 ARF does not, however, possess the self-recovery characteristics of a primary R/C trainer and should be flown only by experienced R/C pilots.

CAUTION (THIS APPLIES TO ALL R/C AIRPLANES): If, while flying, you notice an alarming or unusual sound such as a low-pitched “buzz,” this may indicate control surface *flutter*. Flutter occurs when a control surface (such as an aileron or elevator) or a flying surface (such as a wing or stab) rapidly vibrates up and down (thus causing the noise). In extreme cases, if not detected immediately, flutter can actually cause the control surface to detach or the flying surface to fail, thus causing loss of control followed by an impending crash. The best thing to do when flutter is detected is to slow the model **immediately** by reducing power, then land as soon as safely possible. Identify which surface fluttered (so the problem may be resolved) by checking all the servo grommets for deterioration or signs of vibration. Make certain all pushrod linkages are secure and free of play. If it fluttered once, under similar circumstances it will probably flutter again unless the problem is fixed. Some things which can cause flutter are; Excessive hinge gap; Not mounting control horns solidly; Poor fit of clevis pin in horn; Side-play of wire pushrods caused by large bends; Excessive free play in servo gears; Insecure servo mounting; and one of the most prevalent causes of flutter; Flying an over-powered model at excessive speeds.

Fuel Mixture Adjustments

A fully cowled engine may run at a higher temperature than an un-cowled engine. For this reason, the fuel mixture should be richened so the engine runs at about 200 RPM below peak speed. By running the engine slightly rich, you will help prevent dead-stick landings caused by overheating.

Takeoff

Before you get ready to take off, see how the model handles on the ground by doing a few practice runs at **low speeds** on the runway. Hold “up” elevator to keep the tail wheel on the ground. If necessary, adjust the tail wheel so the model will roll straight down the runway. If you need to calm your nerves before the maiden flight, shut the engine down and

bring the model back into the pits. Top off the fuel, and then check all fasteners and control linkages for peace of mind. Remember to take off into the wind. When you’re ready, point the model straight down the runway, hold a bit of up elevator to keep the tail on the ground to maintain tail wheel steering, and then gradually advance the throttle. As the model gains speed, decrease up elevator, allowing the tail to come off the ground. One of the most important things to remember with a tail dragger is to always be ready to apply **right** rudder to counteract engine torque. Gain as much speed as your runway and flying site will practically allow before gently applying up elevator, lifting the model into the air. At this moment it is likely that you will need to apply more right rudder to counteract engine torque. Be smooth on the elevator stick, allowing the model to establish a gentle climb to a safe altitude before turning into the traffic pattern.

Flight

For reassurance and to keep an eye on other traffic, it is a good idea to have an assistant on the flight line with you. Tell him to remind you to throttle back once the plane gets to a comfortable altitude. While full throttle is usually desirable for takeoff, most models fly more smoothly at reduced speeds.

Take it easy with the Yak 54 1.60 ARF for the first few flights, gradually getting acquainted with it as you gain confidence. Adjust the trims to maintain straight and level flight. After flying around for a while, and while still at a safe altitude with plenty of fuel, practice slow flight and execute practice landing approaches by reducing the throttle to see how the model handles at slower speeds. Add power to see how she climbs as well. Continue to fly around, executing various maneuvers and making mental notes (or having your assistant write them down) of what trim or C.G. changes may be required to fine-tune the model so it flies the way you like. Mind your fuel level, but use this first flight to become familiar with your model before landing.

Landing

To initiate a landing approach, lower the throttle while on the downwind leg. Allow the nose of the model to pitch downward to gradually bleed off altitude. Continue to lose altitude, but maintain airspeed by keeping the nose down as you turn onto the crosswind leg. Make your final turn toward the runway (into the wind), keeping the nose down to maintain airspeed and control. Level the attitude when the model reaches the runway threshold, modulating the throttle as necessary to maintain your glide path and airspeed. If you are going to overshoot, smoothly advance the throttle (always ready on the right rudder to counteract torque) and climb out to make another attempt. When you’re ready to make your landing flare and the model is a foot or so off the deck, smoothly increase up elevator until it gently touches down. Once the model is on the runway and has lost flying speed, hold up elevator to place the tail on the ground, regaining tail wheel control.

One final note about flying your model. Have a goal or flight plan in mind for **every** flight. This can be learning a new maneuver(s), improving a maneuver(s) you already know, or learning how the model behaves in certain conditions (such as on high or low rates). This is not necessarily to improve your skills (*though it is never a bad idea!*), but more importantly so you do not surprise yourself by impulsively attempting a maneuver and suddenly finding that you've run out of time, altitude or airspeed. Every maneuver should be deliberate, not impulsive. For example, if you're going to do a loop, check your altitude, mind the wind direction (anticipating rudder corrections that will be required to maintain heading), remember to throttle back at the top, and make certain you are on the desired rates (high/low rates). A flight plan greatly reduces the chances of crashing your model just because of poor planning and impulsive moves.

Remember to think.

Have a ball! But always stay in control and fly in a safe manner.

GOOD LUCK AND GREAT FLYING!

This model belongs to:

Name

Address

City, State Zip

Phone number

AMA number

ENGINE MOUNTING TEMPLATES

GLOW ENGINE MOUNTING TEMPLATE
(Dashed outline depicts spacing for O.S. Max 1.60 FX)

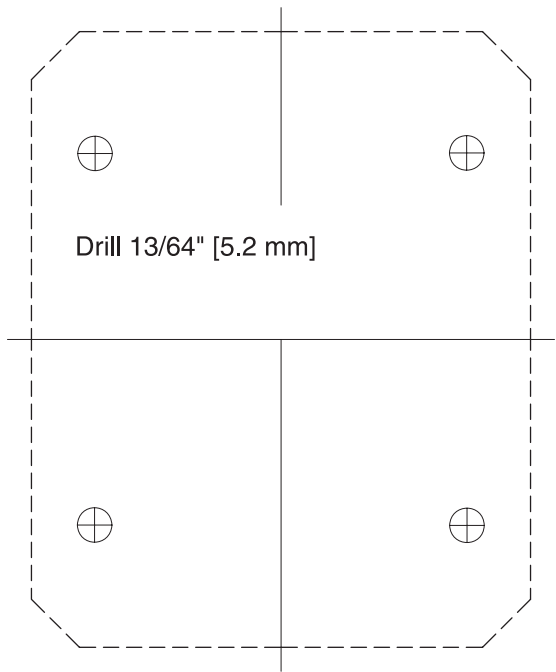

ENGINE MOUNT TEMPLATE FOR FUJI-IMVAC BT-43 EI

