

CAP 232

INSTRUCTION MANUAL



Wingspan: 79 in [2007 mm]

Wing Area: 1168 sq in [75 dm²]

Weight RTF: 12.5-14 lb [5670-6350 g]

Wing Loading: 25-27 oz/sq ft [75-84 g/dm²]

Length: 77 in [1956 mm]

Engine: 1.50-1.80 cu in [25-30cc] two-stroke glow,
1.80-2.10 cu in [30-36cc] four-stroke glow,
or 1.9-2.6 cu in [32-43 cc] gas

WARRANTY

Great Planes® Model Manufacturing Co. guarantees this kit to be free from defects in both material and workmanship at the date of purchase. This warranty does not cover any component parts damaged by use or modification. **In no case shall Great Planes' liability exceed the original cost of the purchased kit.** Further, Great Planes reserves the right to change or modify this warranty without notice.

In that Great Planes has no control over the final assembly or material used for final assembly, no liability shall be assumed nor accepted for any damage resulting from the use by the user of the final user-assembled product. By the act of using the user-assembled product, the user accepts all resulting liability.

If the buyer is not prepared to accept the liability associated with the use of this product, the buyer is advised to return this kit immediately in new and unused condition to the place of purchase.

To make a warranty claim send the defective part or item to Hobby Services at the address below:

Hobby Services
3002 N. Apollo Dr. Suite 1
Champaign IL 61822 USA

Include a letter stating your name, return shipping address, as much contact information as possible (daytime telephone number, fax number, e-mail address), a detailed description of the problem and a photocopy of the purchase receipt. Upon receipt of the package the problem will be evaluated as quickly as possible.

READ THROUGH THIS MANUAL BEFORE STARTING CONSTRUCTION. IT CONTAINS IMPORTANT WARNINGS AND INSTRUCTIONS CONCERNING THE ASSEMBLY AND USE OF THIS MODEL.



Champaign, Illinois
(217) 398-8970, Ext 5
airsupport@greatplanes.com

TABLE OF CONTENTS

INTRODUCTION	2
SAFETY PRECAUTIONS.....	3
DECISIONS YOU MUST MAKE	3
Radio Equipment.....	3
Engine Recommendations	4
Fuel Tank Setup.....	4
ADDITIONAL ITEMS REQUIRED.....	4
Adhesives and Building Supplies	4
Optional Supplies and Tools.....	4
IMPORTANT BUILDING NOTES.....	5
ORDERING REPLACEMENT PARTS	5
KIT CONTENTS	6
ASSEMBLE THE WING	7
Attach the Ailerons	7
Install the Aileron Servos	8
Connect the Ailerons.....	8
Join the Wing.....	10
ASSEMBLE THE FUSELAGE.....	11
Install the Stab and Elevators	11
Install the Radio Trays	13
Install the Rudder	13
Optional Rudder Servo Location (Gas Engine).....	17
Install the Landing Gear.....	17
Glow Engine Installation.....	20
Install the Throttle Servo (Glow Engine)	21
Optional Gas Engine Installation.....	21
Install the Throttle Servo (Gas Engine).....	22
Gas Stopper Assembly.....	23
Glow Stopper Assembly.....	23
Install the Fuel Tank	24
Install the Cowl.....	25
Attach the Canopy.....	26
Mount the Spinner.....	26
Route the Antenna	27
Apply the Decals	27
GET THE MODEL READY TO FLY	28
Check the Control Directions	28
Set the Control Throws.....	28
Balance the Model (C.G.).....	29
Balance the Model Laterally.....	29
PREFLIGHT.....	29
Identify Your Model	29
Charge the Batteries	29
Balance Propellers	30
Ground Check	30
Range Check.....	30
ENGINE SAFETY PRECAUTIONS.....	30
AMA SAFETY CODE	31
General.....	31
Radio Control	31
IMAA SAFETY CODE	31
CHECK LIST	32
FLYING	33
Fuel Mixture Adjustments.....	33
Takeoff.....	33
Flight.....	33
Landing.....	33
ENGINE MOUNT TEMPLATES.....	35

INTRODUCTION

Unlike other larger models, the GP CAP 232 is in a class of its own. It is lightweight, powerful, and adaptable to gas or glow engines. This model will do it all! Outstanding 3D aerobatics are possible in the hands of a capable pilot. For those just learning 3D, the CAP 232 will make an excellent first large scale aircraft, supplying more than enough power for all manner of 3D flight.

For the latest technical updates or manual corrections to the Great Planes CAP 232 ARF, visit the Great Planes web site at www.greatplanes.com. Open the "Airplanes" link, and then select the Great Planes CAP 232 ARF. If there is new technical information or changes to this model, a "tech notice" box will appear in the upper left corner of the page.

AMA

We urge you to join the AMA (Academy of Model Aeronautics) and a local R/C club. The AMA is the governing body of model aviation and membership is required to fly at AMA clubs. Though joining the AMA provides many benefits, one of the primary reasons to join is liability protection. Coverage is not limited to flying at contests or on the club field. It even applies to flying at public demonstrations and air shows. Failure to comply with the Safety Code (excerpts printed in the back of the manual) may endanger insurance coverage. Additionally, training programs and instructors are available at AMA club sites to help you get started the right way. There are over 2,500 AMA chartered clubs across the country. Contact the AMA at the address or toll-free phone number below:



Academy of Model Aeronautics

5151 East Memorial Drive
Muncie, IN 47302-9252
Tele. (800) 435-9262
Fax (765) 741-0057

Or via the Internet at: <http://www.modelaircraft.org>

IMPORTANT!!!

Two of the most important things you can do to preserve the radio controlled aircraft hobby are to avoid flying near full-scale aircraft and avoid flying near or over groups of people.

IMAA

The Great Planes CAP 232 ARF is an excellent sport-scale model and is eligible to fly in IMAA events. The IMAA (International Miniature Aircraft Association) is an organization that promotes non-competitive flying of giant-scale models. If you plan to attend an IMAA event, obtain a copy of the IMAA Safety Code by contacting the IMAA at the address or telephone number below, or by logging on to their web site at: www.fly-ima.org/ima/sanction.html.

IMAA
205 S. Hilldale Road
Salina, KS 67401
(913) 823-5569

PROTECT YOUR MODEL, YOURSELF & OTHERS...FOLLOW THESE IMPORTANT SAFETY PRECAUTIONS

1. Your Great Planes CAP 232 ARF should not be considered a toy, but rather a sophisticated, working model that functions very much like a full-size airplane. Because of its performance capabilities, the Great Planes CAP 232 ARF, if not assembled and operated correctly, could possibly cause injury to yourself or spectators and damage to property.

2. You must assemble the model **according to the instructions**. Do not alter or modify the model, as doing so may result in an unsafe or unflyable model. In a few cases the instructions may differ slightly from the photos. In those instances the written instructions should be considered as correct.

3. You must take time to build **straight, true and strong**.

4. You must use an R/C radio system that is in first-class condition and a correctly sized engine and components (fuel tank, wheels, etc.) throughout the building process.

5. You must correctly install all R/C and other components so that the model operates correctly on the ground and in the air.

6. You must check the operation of the model before **every** flight to insure that all equipment is operating and that the model has remained structurally sound. Be sure to check clevises or other connectors often and replace them if they show any signs of wear or fatigue.

7. If you are not an experienced pilot or have not flown this type of model before, we recommend that you get the assistance of an experienced pilot in your R/C club for your first flights. If you're not a member of a club, your local hobby shop has information about clubs in your area whose membership includes experienced pilots.

8. While this ARF has been flight tested to exceed normal use, if the plane will be used for extremely high stress flying, such as racing, or if an engine larger than one in the recommended range is used, the modeler is responsible for taking steps to reinforce the high stress points and/or substituting hardware more suitable for the increased stress.

9. **WARNING:** The cowl, wheel pants and wing struts included in this kit are made of fiberglass, the fibers of which may cause eye, skin and respiratory tract irritation. Never blow into a part (wheel pant, cowl) to remove fiberglass dust, as the dust will blow back into your eyes. Always wear safety goggles, a particle mask and rubber gloves when grinding, drilling and sanding fiberglass parts. Vacuum the parts and the work area thoroughly after working with fiberglass parts.

We, as the kit manufacturer, provide you with a top quality, thoroughly tested kit and instructions, but ultimately the quality and flyability of your finished model depends on how you build it; therefore, we cannot in any way guarantee the performance of your completed model, and no representations are expressed or implied as to the performance or safety of your completed model.

Remember: Take your time and follow the instructions to end up with a well-built model that is straight and true.

DECISIONS YOU MUST MAKE

This is a partial list of items required to finish the Great Planes CAP 232 ARF that may require planning or decision making before starting to build. Order numbers are provided in parentheses.

Radio Equipment

- 4-channel radio minimum, 6-channel or greater recommended for mixing options.
- 7-channel dual conversion receiver.
- (6) standard size servos capable of a minimum of 70 in oz of torque, i.e. the S3305 SERVO High Torque w/Metal Gears from Futaba® (FUTM0045).
- (1) Throttle servo standard size, i.e. S3004 BB Standard Servo from Futaba (FUTM0004).
- 4.8v - 6.0v receiver pack 1100 mAh or greater.
- Propeller as recommended for your engine choice.
- (2) Command Extension 6" [153 mm] with Futaba J Connectors (HCAM2000).
- Ignition Kill Switch.

If using an 8-channel computerized radio or greater, you also need:

- (6) Command Servo Extensions 24" [610 mm] with Futaba J Connectors (HCAM2200).

If using a 6-channel computerized radio you will need:

- (2) Command Extension 24" [610 mm] with Futaba J Connectors (HCAM2200).
- (2) SR10 Dual Servo Reverser (FUTM4150) for elevators and rudder.

If using a 4-channel radio you will need:

- (2) SR10 Dual Servo Reverser (FUTM4150) for elevators, ailerons and rudder.
- (1) Command Y-Harness with Futaba J Connectors (HCAM2500) for ailerons.

Engine Recommendations

The recommended engine size range for the CAP 232 ARF is specified on the cover of this manual. All engines within the specified range will power this model well. At no time should an engine outside the recommended range be used to fly the CAP 232 because it has not been tested for such use. Powered by a two-stroke glow engine such as the O.S.® MAX 1.60 FX, the CAP 232 performs all aerobatic maneuvers with authority. If flying the CAP 232 with a spark-ignition gas engine is your preference, we recommend the Fuji-Imvac™ Engines 43cc Gasoline Engine (FJIG0143) for optimal performance.

If you haven't yet built a model with a gas engine, but are considering using one, two of the benefits are fuel economy (not only is gasoline cheaper than glow fuel, but gas engines typically burn less fuel as well) and a considerably cleaner exhaust residue. Most gas engines, however, are heavier than glow engines and require premixing gas and oil.

Here are the order numbers for O.S. MAX and Fuji-Imvac engines:

O.S. 1.60 FX ringed **with** muffler (OSMG0660)
O.S. 1.60 FX ringed **without** muffler (OSMG0661)
#5010 muffler for O.S. 1.60 FX engine (OSMG2846)

Fuji-Imvac BT-43EI R/C gas engine (FJIG0143)

Per the IMAA Safety Code, magneto spark-ignition engines must have a coil-grounding switch on the aircraft to stop the engine and prevent accidental starting. The switch must be operated manually (without the use of the transmitter) and be accessible by the pilot and assistant.

Fuel Tank Setup

The fuel tank included with this kit is suitable for use with glow fuel. However, if using a gas engine, the fuel tank must be converted to work with gasoline. This can be done by purchasing a Sullivan #484 Gasoline/Diesel fuel tank conversion kit (SULQ2684), a package of Du-Bro #813 1/8" [3.2 mm] I.D. fuel line barbs (DUBQ0670) and 3' of Great Planes gasoline fuel tubing (GPMQ4135). Without the fuel line barbs, some types of gas-compatible fuel line may slip off the metal fuel tubes. If the Sullivan conversion kit is not available, the Du-Bro #400 gas conversion stopper (DUBQ0675) and one 12" [300 mm] piece of K+S 1/8" [3.2 mm] soft brass tubing (K+SR5128-box of 5) could also be used to make the conversion.

ADDITIONAL ITEMS REQUIRED

Adhesives and Building Supplies

This is the list of Adhesives and Building Supplies that are required to finish the Great Planes CAP 232 ARF.

- Great Planes 1/2 oz. [15g] Thin Pro™ CA (GPMR6001)
- Great Planes 1 oz. [30g] Medium Pro CA+ (GPMR6008)
- Great Planes Pro 30-Minute Epoxy (GPMR6047)
- Great Planes Pro 6-Minute Epoxy (GPMR6045)
- Drill bits: 1/16" [1.6 mm], 5/64" [2 mm], 7/64" [2.8 mm], 3/16" [4.8 mm], 11/64" [4.3 mm]
- Hobbico® Hobby Modeling Knife (HCAR0100)
- Hobbico #11 Blades (5-pack, HCAR0211)
- Hobbico R/C Foam Rubber (1/4" [6 mm] - HCAQ1000)
- Great Planes 3' [900 mm] Standard Silicone Fuel Tubing (GPMQ4131)
- Hobbico CA Applicator Tips (HCAR3780)
- Hobbico Medium T-pins (100, HCAR5150)

Optional Supplies and Tools

Here is a list of optional tools mentioned in the manual that will help you build the Great Planes CAP 232 ARF.

- Hobbico Single-edge razor blades (10-pack, HCAR0212)
- Great Planes 2 oz. [57g] Spray CA Activator (GPMR6035)
- Great Planes CA Debonder (GPMR6039)
- Great Planes Epoxy Brushes (6, GPMR8060)
- Great Planes Mixing Sticks (50, GPMR8055)
- Great Planes Mixing Cups (GPMR8056)
- Hobbico Builder's Triangle Set (HCAR0480)
- Hobbico Curved-Tip Canopy Scissors for Trimming Plastic Parts (HCAR0667)
- Hobbico Duster™ Compressed Air (HCAR5500)
- Top Flite® Masking Tape (TOPR8018)
- Great Planes Threadlocker Thread Locking Cement (GPMR6060)
- Denatured Alcohol (for epoxy clean up)
- Rotary Tool such as Dremel
- Great Planes Rotary Tool Reinforced Cut-Off Wheel (GPMR8200)
- Hobbico Servo Horn Drill (HCAR0698)
- Great Planes Dead Center™ Engine Mount Hole Locator (GPMR8130)
- Great Planes AccuThrow™ Deflection Gauge (GPMR2405)
- Great Planes CG Machine™ (GPMR2400)
- Robart Super Stand II (ROBP1402)
- Great Planes 36" [915 mm] bar for incidence meter (GPMR4021)

IMPORTANT BUILDING NOTES

• There are two types of screws used in this kit:

Sheet metal screws are designated by a number and a length. For example #6 x 3/4" [19 mm]

This is a number six screw that is 3/4" [19 mm] long.

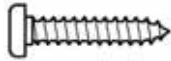

Machine screws are designated by a number, **threads per inch** and a length. For example 4-40 x 3/4" [19 mm]

This is a number four screw that is 3/4" [19 mm] long with forty threads per inch.

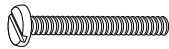

Socket head cap screws (SHCS) are designated by a number, **threads per inch** and a length.

This is a number four screw that is 3/4" [19 mm] long with forty threads per inch.



- When you see the term **test fit** in the instructions, it means that you should first position the part on the assembly **without using any glue**, then slightly modify or *custom fit* the part as necessary for the best fit.
- Whenever the term **glue** is written you should rely upon your experience to decide what type of glue to use. When a specific type of adhesive works best for that step, the instructions will make a recommendation.
- Whenever just **epoxy** is specified you may use **either** 30-minute (or 45-minute) epoxy **or** 6-minute epoxy. When

30-minute epoxy is specified it is **highly** recommended that you use only 30-minute (or 45-minute) epoxy, because you will need the working time and/or the additional strength.

- **Photos** and **sketches** are placed **before** the step they refer to. Frequently you can study photos in following steps to get another view of the same parts.
- The Great Planes CAP 232 ARF is factory-covered with Top Flite MonoKote® film. Should repairs ever be required, MonoKote can be patched with additional MonoKote purchased separately. MonoKote is packaged in six-foot rolls, but some hobby shops also sell it by the foot. If only a small piece of MonoKote is needed for a minor patch, perhaps a fellow modeler would give you some. MonoKote is applied with a model airplane covering iron, but in an emergency a regular iron could be used. A roll of MonoKote includes full instructions for application. Following are the colors used on this model and order numbers for six foot rolls.

True Red (TOPQ0227)	Metallic Charcoal (TOPQ0407)
Jet White (TOPQ0204)	Metallic Blue (TOPQ0402)
- The stabilizer and wing incidences and engine thrust angles have been factory-built into this model. However, some technically-minded modelers may wish to check these measurements anyway. To view this information, visit the web site at www.greatplanes.com and click on "Technical Data." Due to manufacturing tolerances which will have little or no effect on the way your model will fly, please expect slight deviations between your model and the published values.

ORDERING REPLACEMENT PARTS

Replacement parts for the CAP 232 ARF are available using the order numbers in the Replacement Parts List that follows. The fastest, most economical service can be provided by your hobby dealer or mail-order company. Parts may also be ordered directly from Hobby Services, but full retail prices and shipping and handling charges will apply. Illinois and Nevada residents will also be charged sales tax.

To locate a hobby dealer, visit the Great Planes web site at www.greatplanes.com. Choose "Where to Buy" at the bottom of the menu on the left side of the page. Follow the instructions provided on the page to locate a U.S., Canadian or International dealer. If a hobby shop is not available, replacement parts may also be ordered from Tower Hobbies® at www.towerhobbies.com, or by calling toll free (800) 637-6050,

or from Hobby Services by calling (217) 398-0007, or via facsimile at (217) 398-7721. If ordering via fax, include a Visa® or MasterCard® number and expiration date for payment.

Mail parts orders and payments by personal check to:

Hobby Services
3002 N Apollo Drive, Suite 1
Champaign IL 61822

Be certain to specify the order number exactly as listed in the **Replacement Parts List**. Payment by credit card or personal check only; no C.O.D.

If additional assistance is required for any reason, contact the appropriate Product Support by telephone at (217) 398-8970 or by e-mail at productsupport@greatplanes.com.

Description	How to Purchase
Missing pieces.....	Contact Product Support
Instruction manual.....	Contact Product Support
Full-size plans	Not available
Kit parts listed below	Hobby Supplier

Replacement Parts List

GPMA2861Wing Set	GPMA2866Landing Gear
GPMA2862Fuselage Kit	GPMA2867Wheel Pants
GPMA2863Tail Surface Set	GPMA2868Tailwheel Assembly
GPMA2864Cowl	GPMA2869Decal Sheet
GPMA2865Canopy	

KIT INSPECTION

Before starting to build, take an inventory of this kit to make sure it is complete, and inspect the parts to make sure they are of acceptable quality. If any parts are missing or are not of acceptable quality, or if you need assistance with assembly, contact Great Planes **Product Support**. When reporting defective or missing parts, use the part names exactly as they are written in the Kit Contents list on this page.

Great Planes Product Support:
Telephone: (217) 398-8970, ext. 5
Fax: (217) 398-7721
E-mail: airsupport@greatplanes.com

KIT CONTENTS

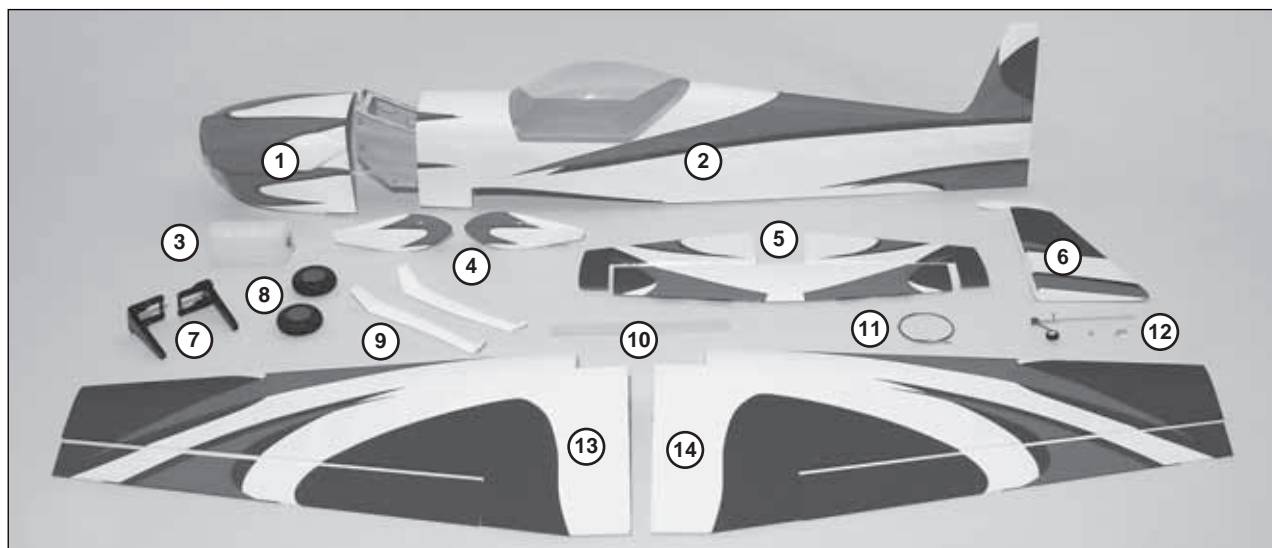

Kit Contents (Photographed)

- | | | |
|---|---|--|
| <ul style="list-style-type: none"> 1 Cowl 2 Fuselage 3 Fuel Tank Assembly 4 Wheel Pants (2) 5 Stabilizer and Elevators | <ul style="list-style-type: none"> 6 Rudder 7 Engine Mount 8 3.5" Main Wheels (2) 9 Landing Gear Struts 10 Wing Joiner | <ul style="list-style-type: none"> 11 Pull-Pull Cable 12 Tailwheel Assembly 13 Left Wing Panel with Aileron 14 Right Wing Panel with Aileron |
|---|---|--|

Kit Contents (Not Photographed)

- | | | |
|--|---|--|
| <ul style="list-style-type: none"> 4-40 Steel Clevis Threaded (8) Solder Clevis for .095 Wire (6) 2x3/16" Bolt-On Axle Shaft (2) Brass Quick Connector (1) 4-40 Blind Nut (4) 4-40 Hex Nut (8) 6-32 Blind Nut (6) 8-32 Blind Nut (4) 1/4-20 Blind Nut (2) Nylon 1/4-20 x 2" Bolt (2) Nylon Clevis (1) | <ul style="list-style-type: none"> Heavy Duty Control Horn (6) Quick Connector Retainer (1) 1/4" Clevis Retainer (13) #2 x 3/8" Screw (4) #4 x 1/2" Sheet Metal Screw (30) 6-32 x 1/4" Socket Head Bolt (4) 3/16" Wheel Collar (4) #6 Flat Washer (6) #4 Flat Washer (10) #2 Flat Washer (12) #8 Lock Washer (8) | <ul style="list-style-type: none"> #8 Flat Washer (8) #6 Lock Washer (6) .074 x 12" Wire Threaded One End (1) .095 x 5.75" Wire Threaded One End (6) 4-40 x 1/4" Socket Head Cap Screw (1) 4-40 x 1/2" Socket Head Cap Screw (4) 6-32 x 1-1/4" Socket Head Cap Screw (6) 8-32 x 1-1/4" Socket Head Cap Screw (4) 8-32 x 1" Socket Head Cap Screw (4) 2-56 x 3/8" Machine Screw (8) |
|--|---|--|

ASSEMBLE THE WING

Before beginning assembly on your new Great Planes CAP 232, tighten all covering with an iron or heat gun if needed.

Attach the Ailerons

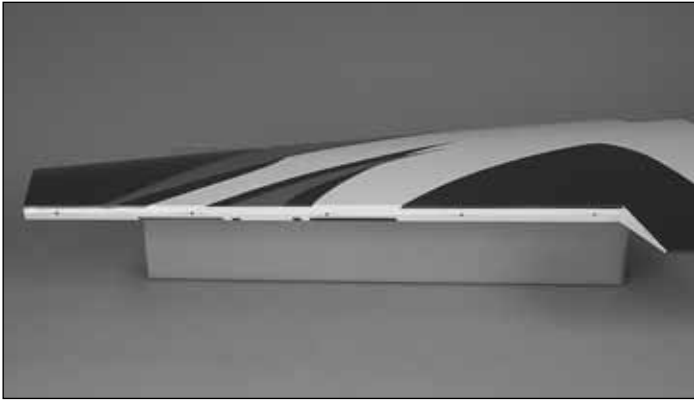

1. Cut the covering away from the five predrilled holes in the left **aileron** and left **wing panel**.

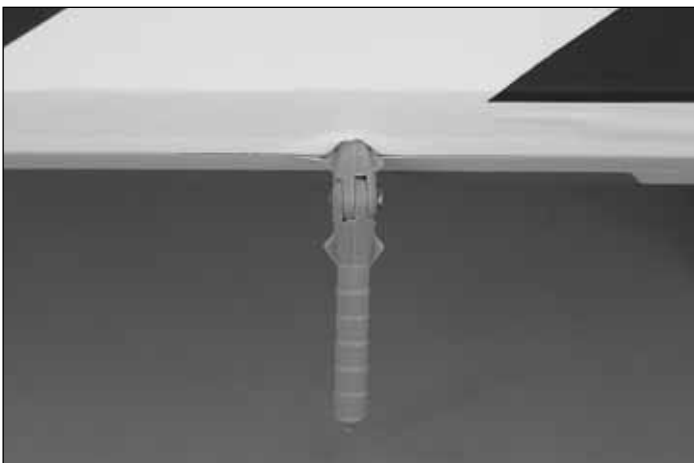
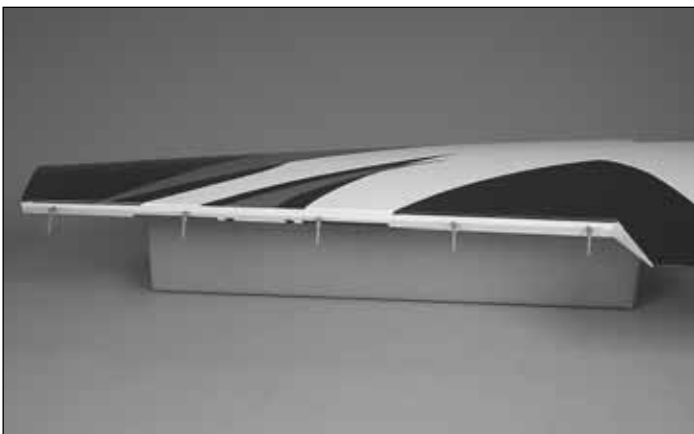

2. Locate five **point hinges**. Test fit each hinge by temporarily attaching the aileron to the wing. Note the “wings” on each hinge near the pivot. These are designed to align the hinge and prevent it from rotating. It will take a small amount of force to push these wings into the wood.

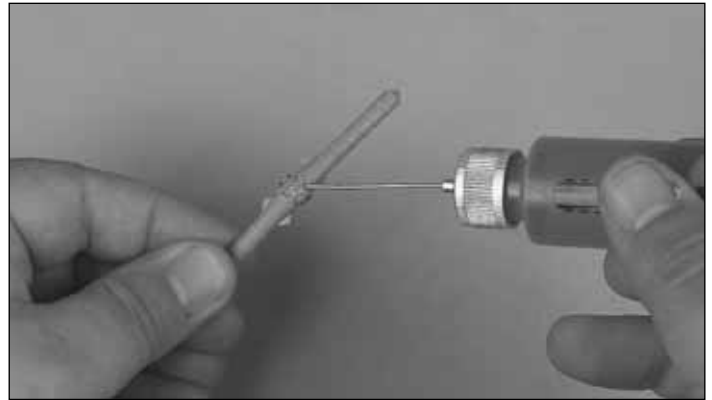

3. Apply a small drop of oil to the pivot on each hinge.

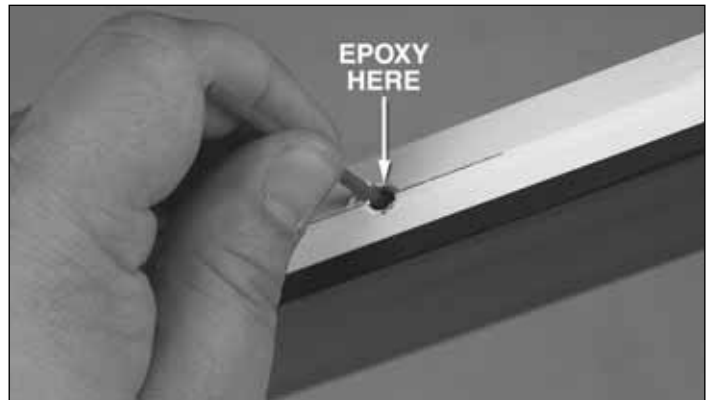

4. Mix approximately 1/8 oz of 30-minute epoxy. Use a toothpick to **thoroughly** apply the epoxy in the holes in the aileron. Use the toothpick to get the epoxy out of the outer edge of the opening of the holes in the aileron so it doesn't get into the hinge pins. Wipe away any epoxy around the outside of the holes with a paper towel.

5. Push the point hinges into the holes in the aileron, be sure to clean any epoxy squeezed out using alcohol and a paper towel.

6. Once the epoxy has cured, mix 30-minute epoxy and use a toothpick to thoroughly apply the epoxy in the holes in the wing.

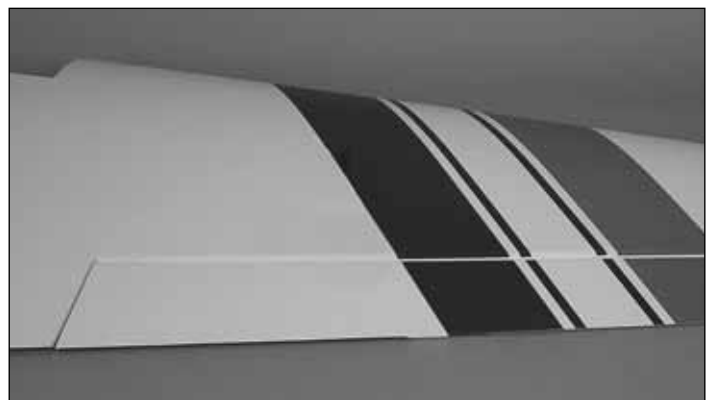

7. Fit the hinges in the wing and aileron. Tape the aileron to the wing and set aside until the epoxy has cured.

8. Repeat steps 1-4 for the other wing half.

Install the Aileron Servos



1. Connect a 12" [305 mm] servo extension to the aileron servo and secure the connections with heat shrink tubing or some other method such as tape or clamps designed to hold servos together (not included).



2. Carefully remove the covering from the aileron servo bay on the bottom of the wing using a sharp hobby knife. Seal the covering down at the edge of the hole using an iron.

3. Locate the servo lead exit hole in the top of the wing. Carefully remove the covering from this hole using a sharp hobby knife.



4. Located in the wing in the aileron servo compartment, a string is taped to the inside of the wing covering. Tie the string to the end of the servo wire. Then pull the servo wire through the wing with the string. Feed the servo wire out of the hole in the top of the wing. Tape the servo wire to the wing to prevent it from falling back into the opening.



5. Install the servo into the servo opening. Drill through the servo mounting holes with a 1/16" [1.6 mm] drill bit. Remove the servo from the servo opening. Install and then remove a servo mounting screw into each of the holes you have drilled. Apply a drop of thin CA into the holes to harden the threads. Once the glue has hardened, install the servo into the servo opening using the hardware included with your servo. Center the servo, and then install a servo arm pointing towards the wingtip.

6. Repeat steps 1-5 for the other wing panel.

Connect the Ailerons

1. Align the aileron at neutral and hold in place using masking tape. Be sure the servo is centered.



2. Fit a silicone retainer, one 4-40 nut, another silicone retainer and the clevis on the end of a 4-40 threaded one end pushrod. Screw the clevis on 14 turns and temporarily connect it to the aileron servo arm.

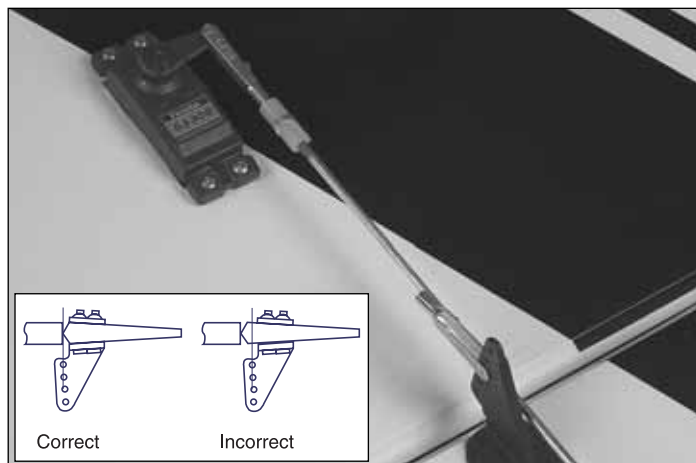

3. Attach one solder clevis to a black nylon control horn and position it on the aileron as shown in the sketch

and aligning it with the servo. Mark the location for the screw holes. Drill pilot holes in the marks you made with a 1/16" [1.6 mm] drill bit, **being careful not to drill through the aileron**. Secure the control horn to the aileron with four #4 x 1/2" [13 mm] screws. Remove the screws, harden the holes with thin CA, and then reinstall the screws.

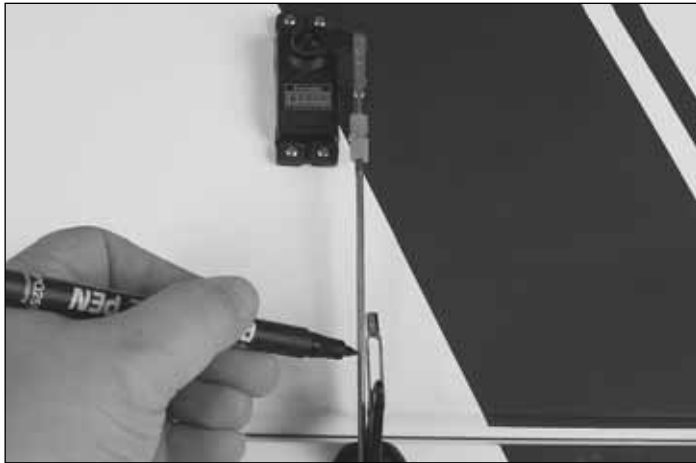

4. Align the pushrod with the clevis on the control horn and make a mark using permanent marker or Panel Line Pen where the pushrod extends 1/8" [3 mm] into the open area of the clevis. Trim the 4-40 rod to length.

5. Remove the clevis and pushrod assembly from the servo and the solder clevis from the control horn.

6. Attach the solder clevis to the pushrod using the expert tip at the end of this section.



7. Reattach the pushrod assembly as shown. Be sure to slide the silicone retainers over the clevises.



HOW TO SOLDER

A. Use denatured alcohol or other solvent to thoroughly clean the pushrod. Use coarse sandpaper to roughen the end of the pushrod where it is to be soldered.



B. Apply a few drops of soldering flux to the end of the pushrod. Position the clevis so that 1/8" of the pushrod protrudes into the open area of the clevis.

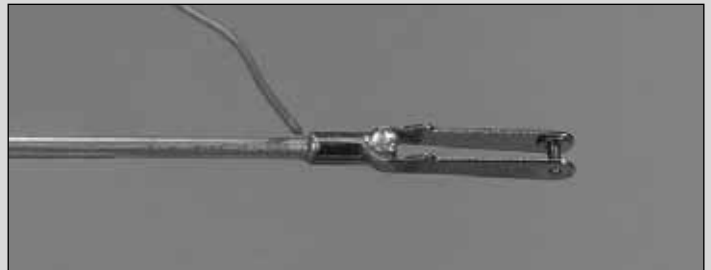

C. Simultaneously heat the clevis and pushrod. Apply silver solder (GPMR8070) to the joint. The heat of the parts being soldered should melt the solder, thus allowing it to flow.

D. Immediately after the solder has solidified, but while it is still hot, carefully use a cloth to quickly wipe off the flux before it hardens. Important: After the joint cools, coat with oil to prevent rust. **Note:** Do not use the acid flux that comes with silver solder for electrical soldering.



E. This is what a properly soldered clevis looks like; shiny solder with good flow, no blobs, flux removed.

8. Repeat steps 1-7 for the other aileron servo.

Join the Wing

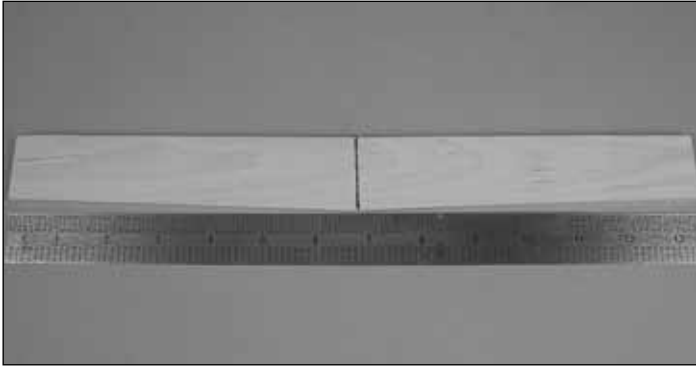

1. Locate the **wing joiner**. Measure and mark the centerline of the joiner.

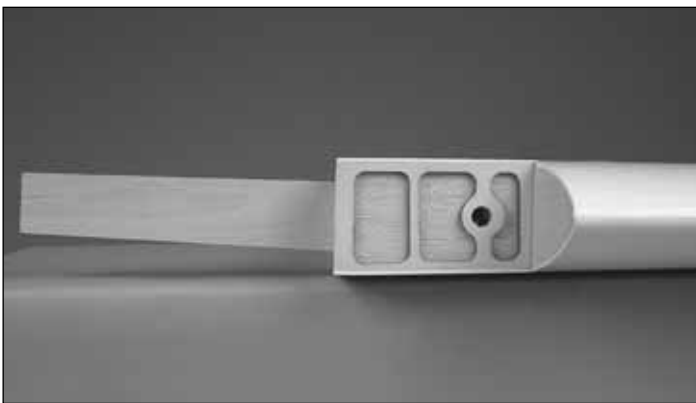

2. Test fit the wing joiner in one half of the wing. Sand as needed to allow the joiner to fit snug in the wing. Then slide the other wing half onto the joiner. There should be no gap between the wing halves when joined. Note the direction of the joiner. The "V" of the joiner should be towards the bottom of the wing.

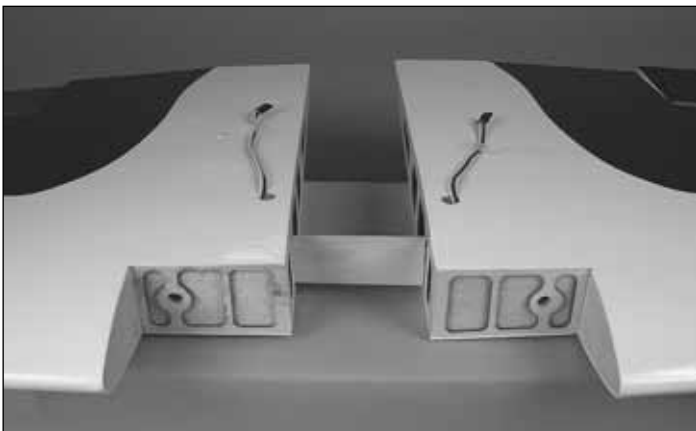

3. When satisfied with the fit, separate the wing panels and remove the joiner. Mix a large batch of epoxy, enough to cover one half of the wing joiner and the inside of one wing joiner pocket. Half of one epoxy mixing cup, or 1/2 oz of epoxy should work fine. Coat half of the wing joiner and one wing joiner pocket with epoxy and insert the joiner. Clean up any epoxy that oozes out using a paper towel and denatured alcohol. Allow the epoxy to fully harden before proceeding.

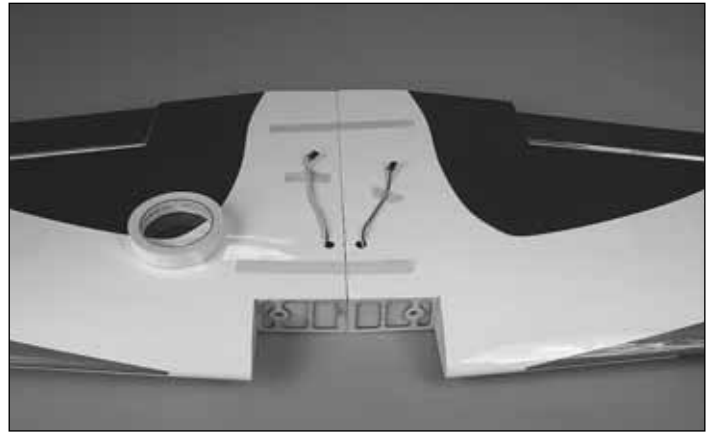

4. Mix another large batch of 30-minute epoxy, 1 oz should do. Coat the other half of the wing joiner, wing joiner pocket and the two wing roots with 30-minute epoxy. Join the two wing halves and hold them together with masking tape until the epoxy has completely hardened. Clean up any excess epoxy with alcohol and a paper towel.

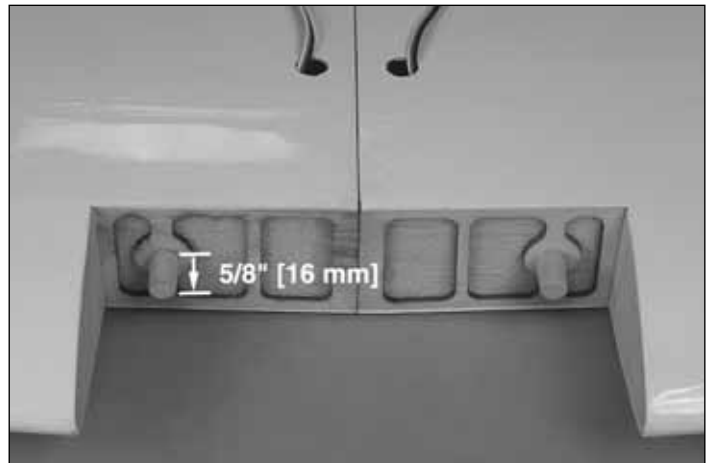

5. Locate the two 3/8" [10 mm] x 2" [51 mm] **wooden wing dowels**. Round the edges of the dowels. Test fit the dowels into the holes in the forward center section of the wing as shown. Approximately 5/8" [16 mm] of the dowel should be sticking out of the wing. Glue in place using epoxy.



6. Locate the wing bolt holes in the aft center section of the wing. Remove the covering from these holes on the top and bottom of the wing using a sharp hobby knife.

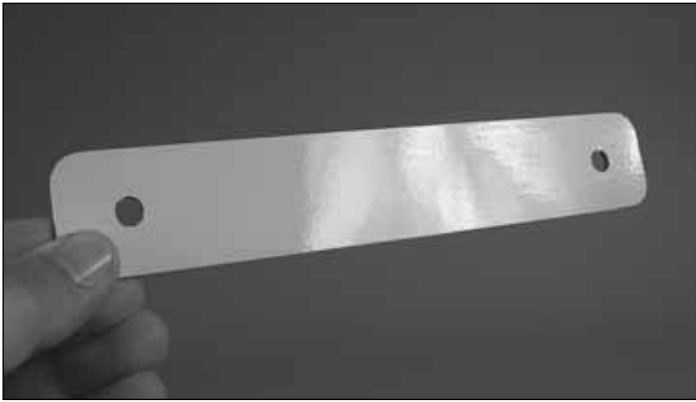

7. Locate the **wing bolt plate**. Remove the covering from the holes in the plate using a sharp hobby knife.

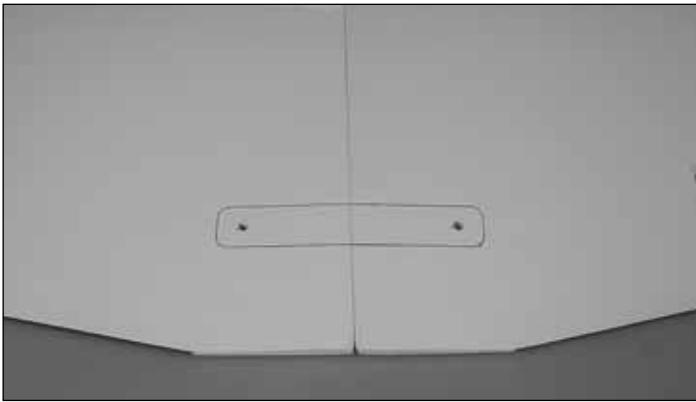

8. Align the holes in the wing bolt plate with the holes in the wing. Trace an outline around the wing bolt plate. Trim away the covering approximately 3/32" [2 mm] inside the outline. Be careful not to cut into the balsa structure as this could weaken the wing.



HOW TO CUT COVERING FROM Balsa

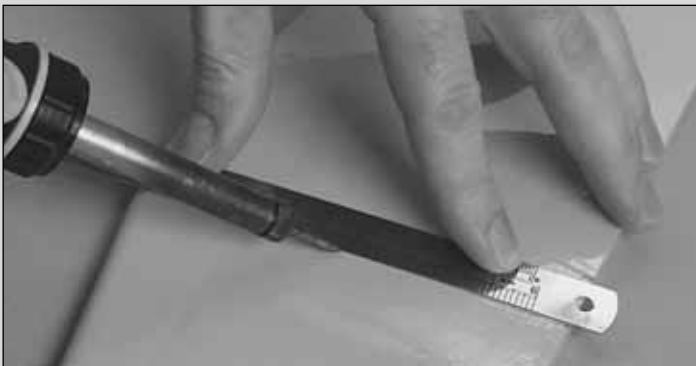

Use a soldering iron to cut the covering from the stab. The tip of the soldering iron doesn't have to be sharp, but a fine tip does work best. Allow the iron to heat fully. Use a straightedge to guide the soldering iron at a rate that will just melt the covering and not burn into the wood. The hotter the soldering iron, the faster it must travel to melt a fine cut.

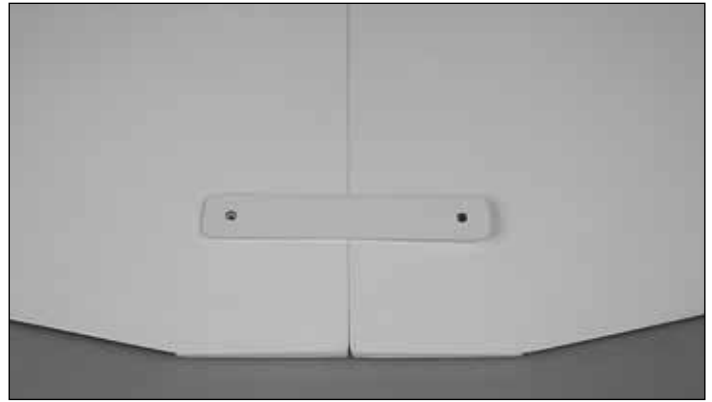

9. Glue the wing bolt in place using medium CA. After the plate is installed, run a bead of medium CA around the edges of the plate to prevent fuel from soaking into the balsa.

ASSEMBLE THE FUSELAGE

Install the Stab and Elevators



1. Locate the stab mounting slots near the rear of the fuse and remove the covering using a sharp hobby knife.

2. Attach the wing to the fuselage using the two 1/4-20 nylon bolts.

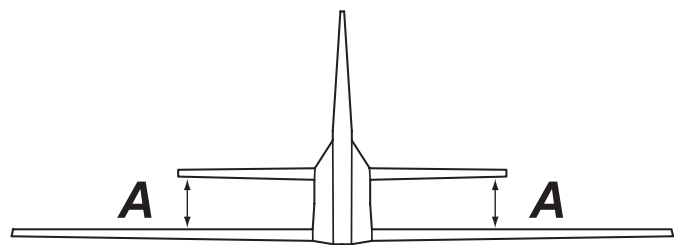

A = A

3. Test fit the **stab** into the opening in the back of the fuselage. Stand back and look at the stab in relation to the wing. The stab should be parallel with the wing. If not, sand the stab saddle until the stab and wing are aligned.

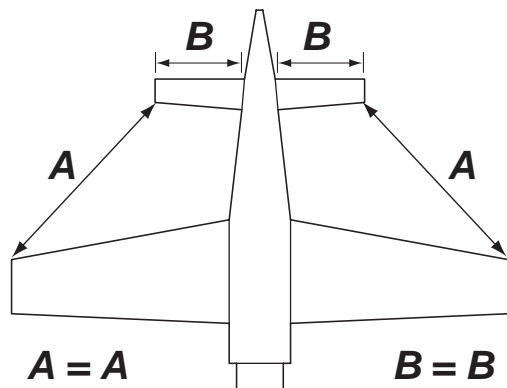

- ❑ 4. Measure the distance from the tip of the stab to the tip of each wing. Also measure the distance on each side of the fuselage. Adjust the position of the stab until $A=A$ and $B=B$.

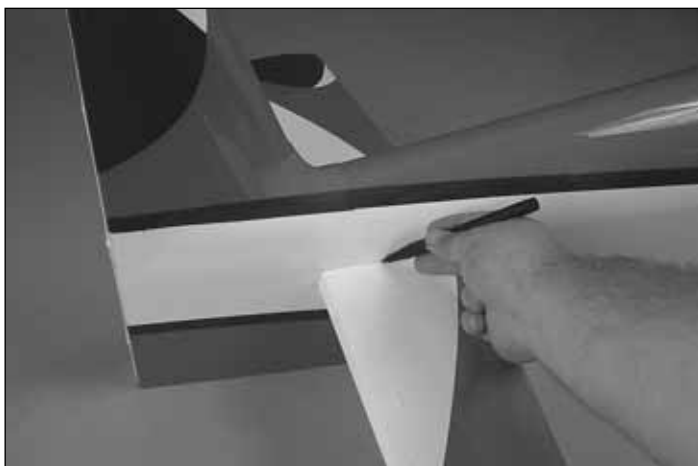

- ❑ 5. Trace the outline of the fuselage onto the stab using a felt tip marker or Panel Line Pen. Do this on both the top and bottom of the stab.

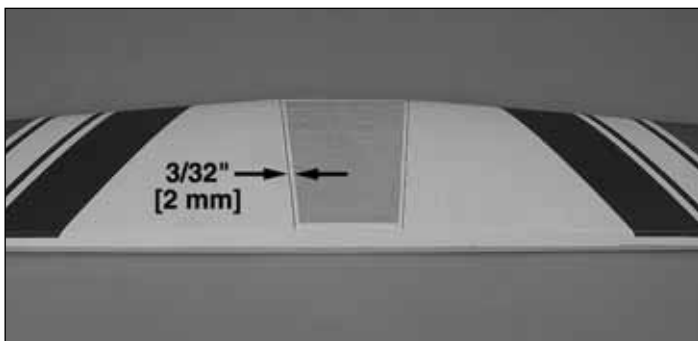

- ❑ 6. Remove the covering from the center section of the stab $3/32"$ [2 mm] inside the marked line, being careful not to cut into the wood structure.

- ❑ 7. Glue the stab in place using 30-minute epoxy. Be sure to check your measurements periodically to ensure the stab does not move while the epoxy is curing. Allow the epoxy to fully harden before proceeding. Once the epoxy has fully hardened, you may remove the main wing to make the plane easier to handle.

- ❑ 8. Attach the elevators to the stab following the same technique used for the ailerons.

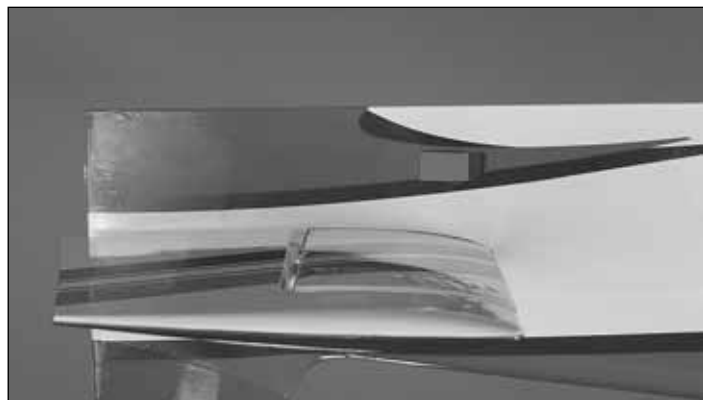

- ❑ 9. Locate the two elevator servo bays in the rear of the fuselage, one on each side of the fuselage. Remove the covering from these bays using a sharp hobby knife. Note there are two cutouts on each side that can accommodate a servo. Cut the covering from the servo bays **closest to the top of the fuselage**, nearest the stab.

- ❑ 10. Attach a 24" [610 mm] servo extension to both elevator servos. Secure the connections with heat shrink tubing or some other method (not included).



- ❑ 11. Route the servo lead through the fuselage and install the servo with the output spline toward the nose of the plane as shown. Center the servo by temporarily connecting it to the radio system and attach a servo arm. Remove the servo mounting screws and harden the holes for the servos with thin CA. Allow the CA to fully dry before reinstalling the screws.



- ❑ 12. Follow the same procedure as the ailerons for connecting the pushrod and installing the control horns for both elevator halves.

Install the Radio Trays

Note: This section applies to gas engines **ONLY**.

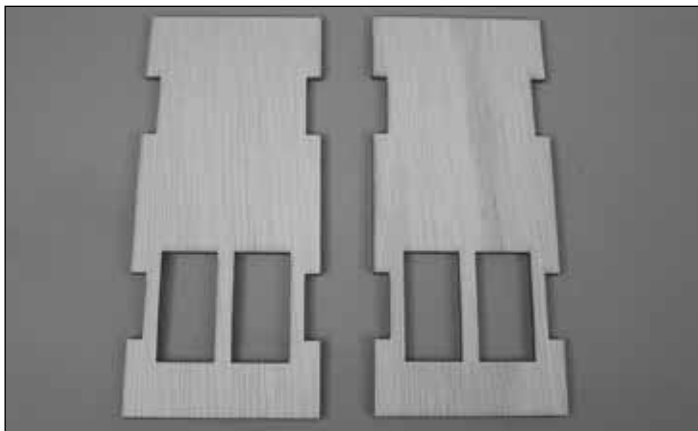

1. Locate the two 1/8" [3.2 mm] **plywood radio trays**. If you are installing a gasoline engine, these trays have cutouts for your throttle servo.

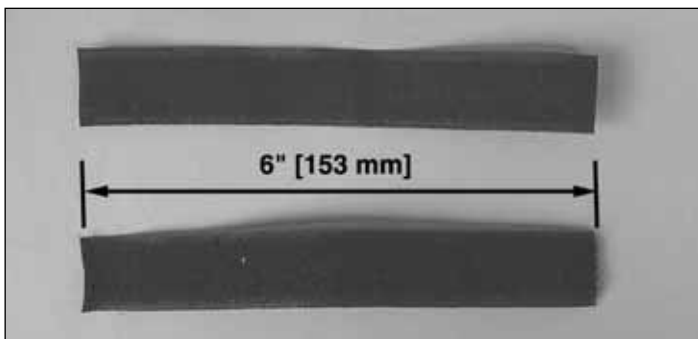

2. Locate the black hook and loop tape supplied with the ARF. Cut it into equal lengths of approximately 6" [153 mm].

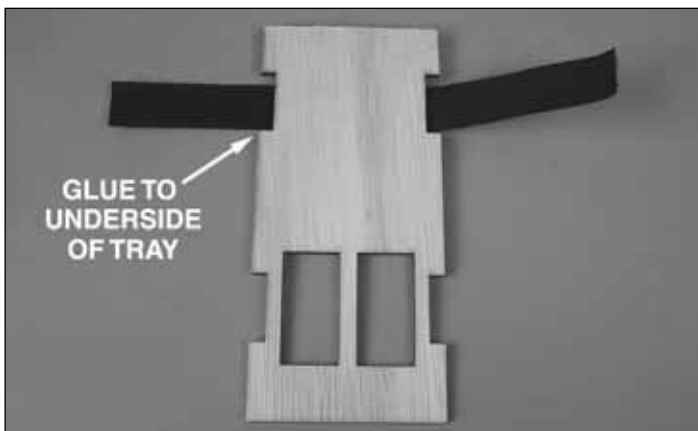

3. Overlap 2" of the hook and loop sides of the tape and press together. Loop around the plywood radio tray as shown.



4. Align the radio trays as shown in the photo. Glue the radio trays in place using medium or thick CA. For added strength, epoxy may be used.

Install the Rudder

For the CAP 232, there are a couple of variations on how the rudder servos are installed. They can be mounted in the tail of the aircraft just aft and below the elevator servos or they can be mounted in a pull-pull configuration. For simplicity's sake in the manual, the setup referenced is the configuration that required the least amount of additional weight to balance the model. Of course, it is up to you the modeler to determine the method used.

The following text details the installation of the pull-pull system for a typical glow engine installation. If you are installing a gas engine and do not wish to use the pull-pull setup, refer to the optional servo location for gas engine installation section for installing the servos in the aft servo bays.

1. Attach the **rudder** using point hinges following the procedure used for the ailerons and elevators.

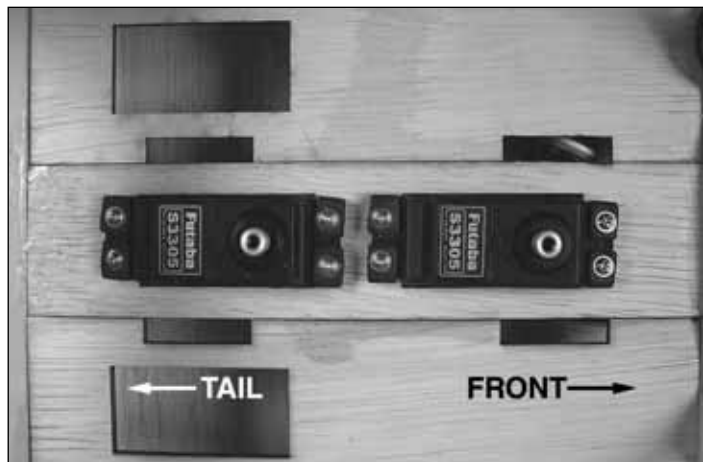

2. Install two rudder servos in the servo tray as shown using the hardware provided by your manufacturer. Be sure each servo's output shaft is pointed towards the front of the fuselage.

❑ 3. Locate the two 3-3/4" [95 mm] aluminum double servo arm extensions supplied with this kit and two large servo wheels supplied by your servo manufacturer. For our manual we used Futaba servos and the large wheel supplied. Your manufacturer's servo wheels may vary slightly.

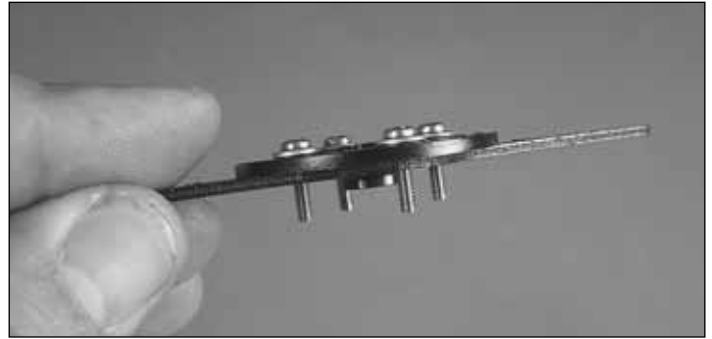
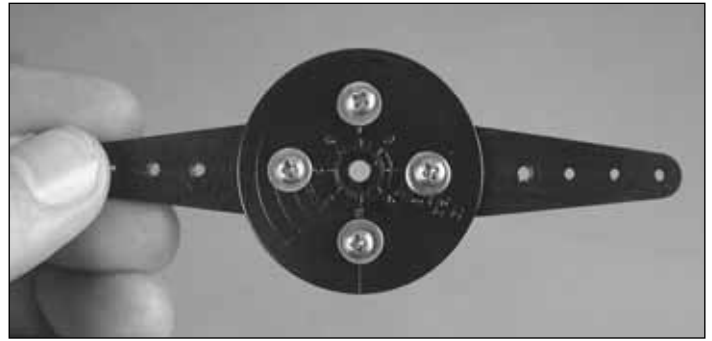

❑ 7. Use four 2-56 x 3/8" [9.5 mm] machine screws and #2 washers to attach the extender to the wheel as shown. Be sure to add a drop of threadlocker to the screws.



❑ 8. Trim the 2-56 screws flush with the bottom of the extender using a rotary tool such as a Dremel, or a pair of heavy-duty wire cutters.

❑ 9. Enlarge the third hole from the center on each side of your servo arm extenders with a 3/32" [2.4 mm] drill bit.

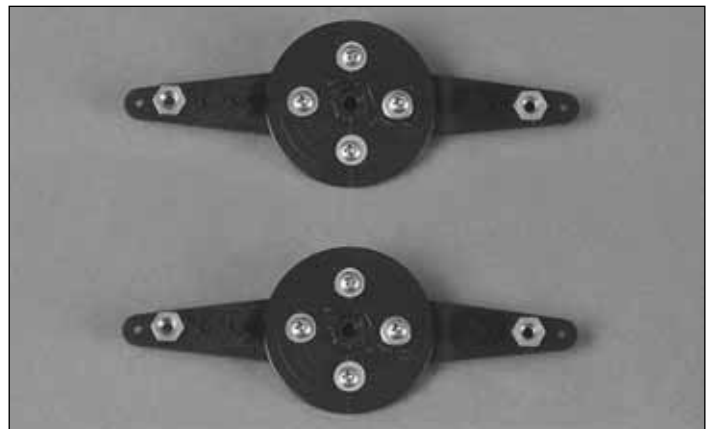

❑ 10. Install two screw lock connectors into the third hole on each side of the servo arm extension as shown.



❑ 4. Test fit the servo arm extension as shown. The servo arm extension should self-center on the servo wheel.

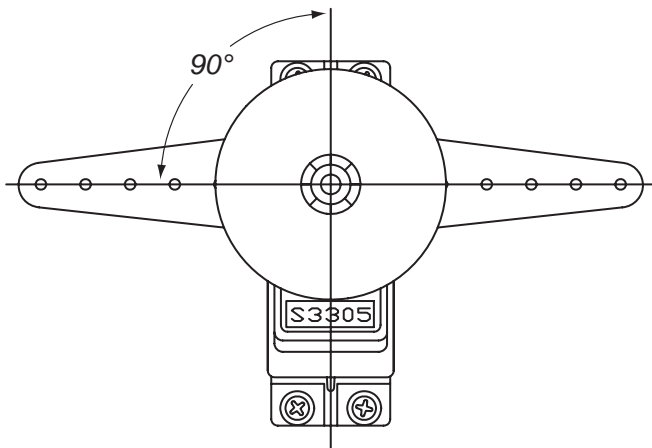

❑ 5. Using your radio, center both rudder servos. Attach the servo wheels with the extender to the servo. Align the arm extender so that it is perpendicular to the servo as shown. Use a small drop of medium CA to tack glue the arm in place once you have it aligned correctly.

❑ 6. Carefully remove the servo wheel and extender from the servo. Using a felt tip pen, mark the location of the four mounting holes in the arm extender on the servo wheel. Remove the wheel and extender and drill 5/64" [2 mm] holes through marks you made.

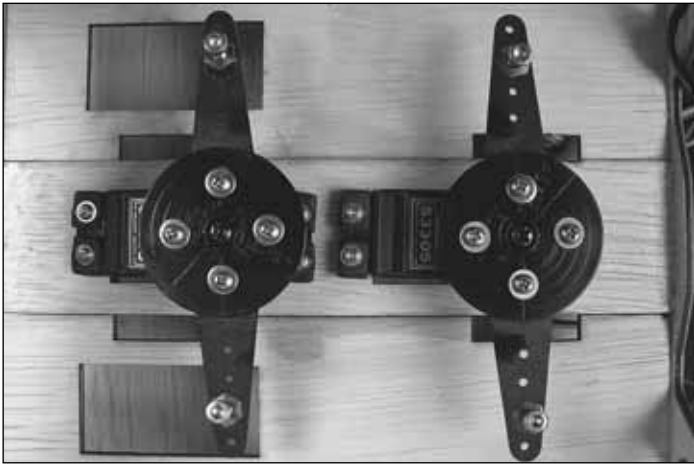

❑ 11. Attach both servo arms to the servo, ensuring they are perfectly parallel.



❑ 13. Remove the covering from the two teardrop shaped pull-pull cable exits at the rear of the fuselage.

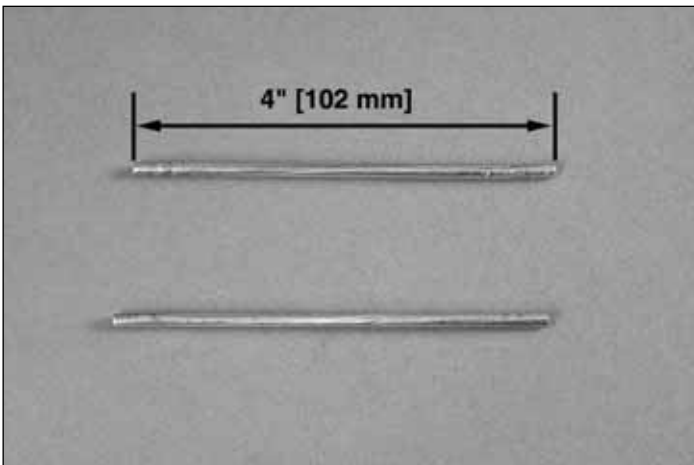

❑ 14. Trim the two rudder control horns as shown. This is necessary to allow the elevator halves to clear the horns.

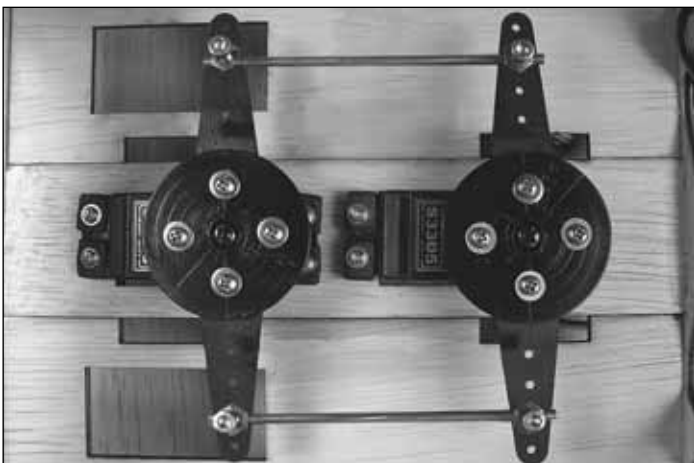

❑ 12. Locate the two 5-1/4" [133 mm] 4-40 pushrod segments. Cut each pushrod to 4" [102 mm]. Then insert the two pushrods through the screw lock connectors on both rudder servo arms. Lock the pushrods in place using 4-40 x 1/8" [3.2 mm] SHCS. Add a drop of Threadlocker to each screw to hold in place.

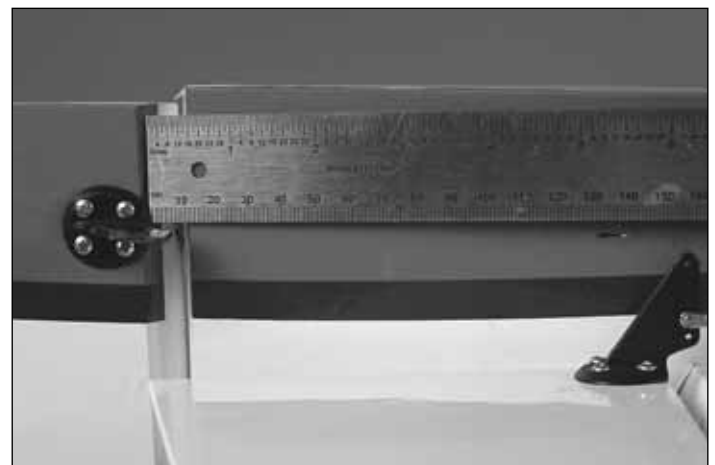

❑ 15. Use a ruler to position the control horns on each side of the rudder. Align the holes in the control horn with the hinge line. Drill 1/16" [1.6 mm] pilot holes in the rudder at the screw mounting locations. Attach the rudder control horns using four #4 x 1/2" [13 mm] sheet metal screws on each control horn. Remove the screws and harden the screw holes with some thin CA. Allow the glue to fully harden before permanently installing the mounting screws.

16. Hold two ends of the pull-pull cable together, making sure they are even. Cut the cable at the midpoint to create two equal lengths. Route the non-threaded end of the cable through the hole in the rear of the fuselage. Pull the cable through the fuselage to the rudder servos.

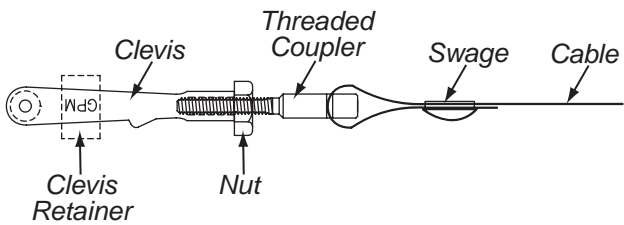
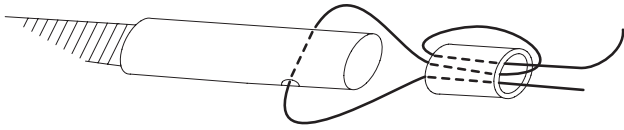

17. Assemble one end of each half of the cable as shown in the sketches above. Each clevis should be threaded halfway onto the coupler. Do not crimp the swage fitting yet as it will need to slip for adjustments.

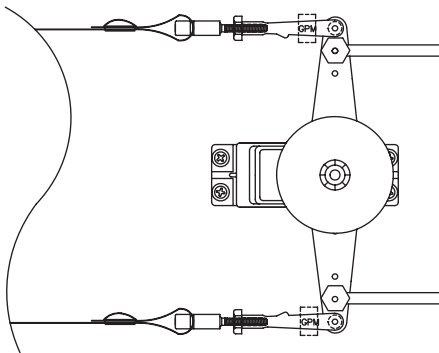

18. Attach the clevis end of the cable to the 3rd hole out on the rudder control horns and route the unassembled end of the cable into the fuselage through the teardrop shaped holes in the tail. Pull the cable forward to the rudder servos.

19. Assemble the remaining end of the cable as you did before.

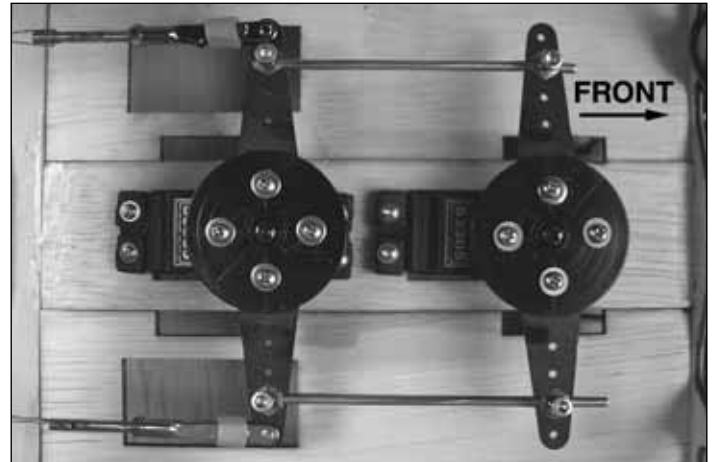
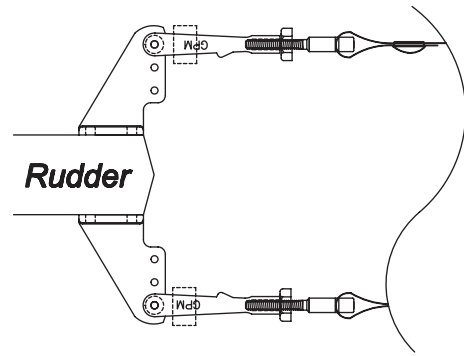

20. Connect the pull-pull cables to the aft rudder servo arm extension as shown.

21. Once both cables are installed, turn on your radio and center the servo arms. Center the rudder.

22. With the radio still on and the rudder centered, pull the slack from each cable at the clevises. Do not pull the cables too tight. A **slight** amount of slack is acceptable.

23. When satisfied with the cable tension, crimp the swage fitting securely in place using pliers. This will secure the cable length.



24. Fine tuning of the cable tension can be performed by adjusting the clevis on the coupler. When done adjusting the tension, secure the clevis by tightening the nut against the clevis. Be sure to apply a drop of thread locker to hold the nut in place.

Optional Rudder Servo Location (Gas Engine Installation)

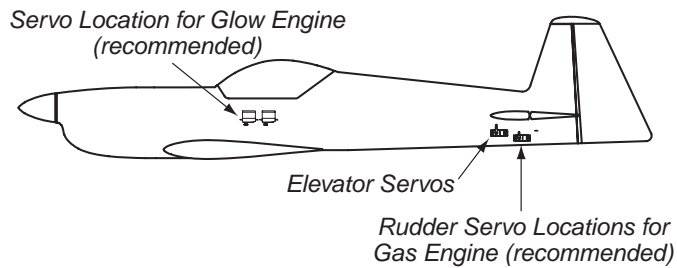

- ❑ 1. For a typical gas engine installation, it is easiest to get the CAP 232 to balance by installing the rudder servos in the aft servo bays. These are located just behind and slightly below the elevator servo bays as shown in the sketch.

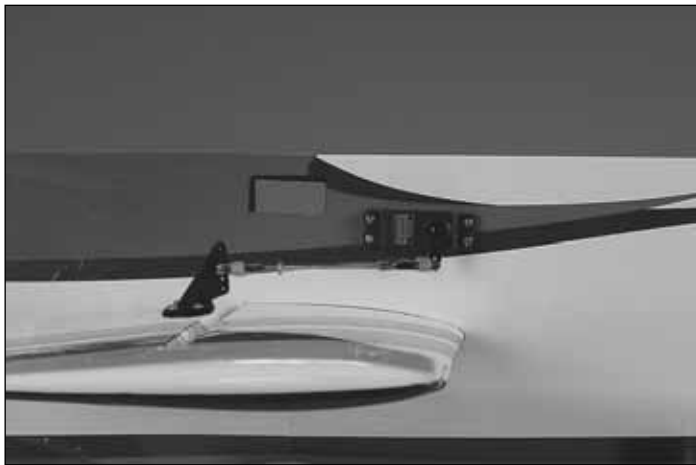

- ❑ 2. Remove the covering from the rudder servo bays using a sharp hobby knife.

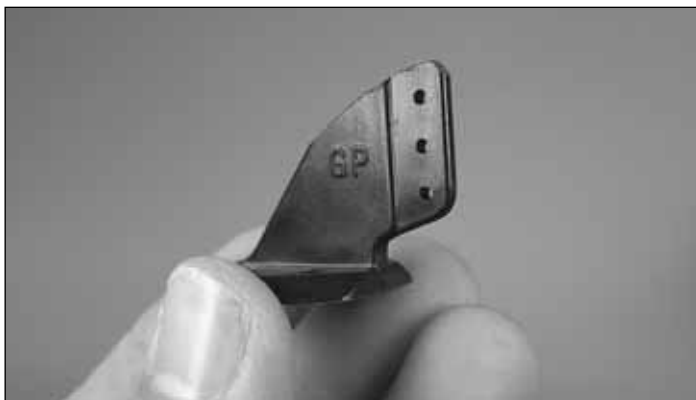

- ❑ 3. Trim the two rudder control horns as shown. This is necessary to allow the elevator halves to clear the horns.

- ❑ 4. Install the rudder servos with 36" [915 mm] servo extensions attached. Secure the connections using heat shrink as you did before. The servos output shaft should point toward the nose of the aircraft with the servo arm pointing toward the top of the fuselage.

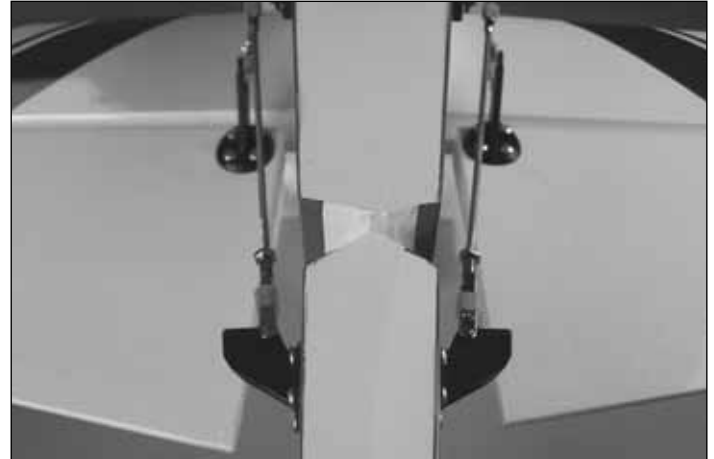
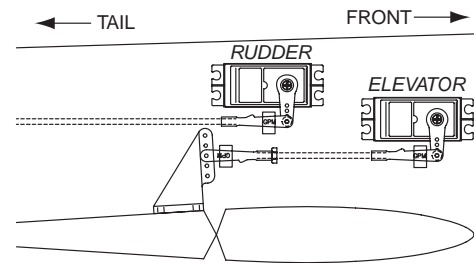

- ❑ 5. Use the same procedure as done with the elevator halves to create pushrods and align the control horns. Final installation will resemble the picture above.

Install the Landing Gear



- ❑ ❑ 1. Attach one 3/16" [4.8 mm] x 2" [51 mm] axle to a main gear strut. Use a 5/16" [8 mm] nylon lock nut on the back side of the axle as shown.

- ❑ ❑ 2. Slide a 3/16" [4.8 mm] wheel collar, 3.5" [89 mm] main wheel, and another 3/16" [4.8 mm] wheel collar onto the axle as shown.



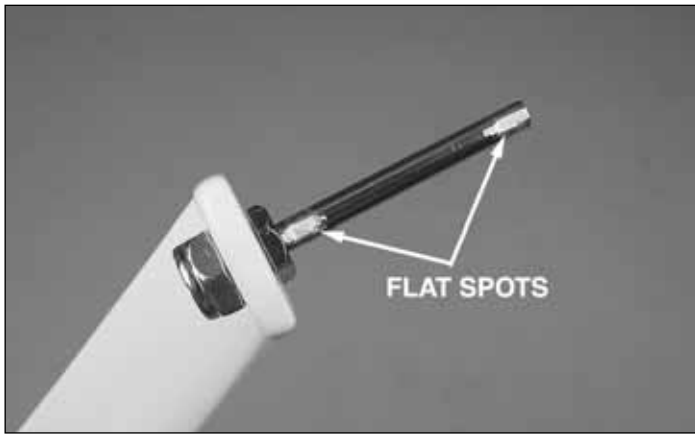

3. File flat spots on the wheel axle where the wheel collar set screws will tighten down. A rotary tool with a flat grinding disc works well for this.



4. Reinstall the wheel collars and main wheel. Apply a small amount of thread locking compound to the wheel collar set screws and tighten them in place. Trim off the excess axle, leaving 1/8" [3.2 mm] extending past the wheel collar. A rotary tool and cut off disc or flat file works best for this.



5. Slide the **fiberglass wheel pant** over the main wheel and align the holes in the main gear with the holes in the wheel pant. Using two 4-40 x 1/2" [13 mm] SHCS, #4 lock washers and #4 washers, attach the wheel pant to the gear leg. Add a drop of Threadlocker to each 4-40 SHCS. Note the direction of the gear leg in relation to the pant in the photo.



6. Mount the left and right landing gear assemblies to the fuselage using six 6-32 x 1-1/4" [32 mm] SHCS, six #6 washers, and six #6 lock washers as shown.



7. Locate the **tailwheel assembly**, **nylon tail gear bearing**, **nylon rudder post**, **tail gear support**, and **large wheel collar**. If it has not already been done for you, slide the 1" [25 mm] tailwheel and small wheel collar onto the tail wheel wire as shown. Grind a flat spot on the wire as you did with the main landing gear axles where the set screw tightens down.



❑ 8. Locate the small cutout on the tail of the fuselage for the tail gear bearing. Remove the covering using a sharp hobby knife.

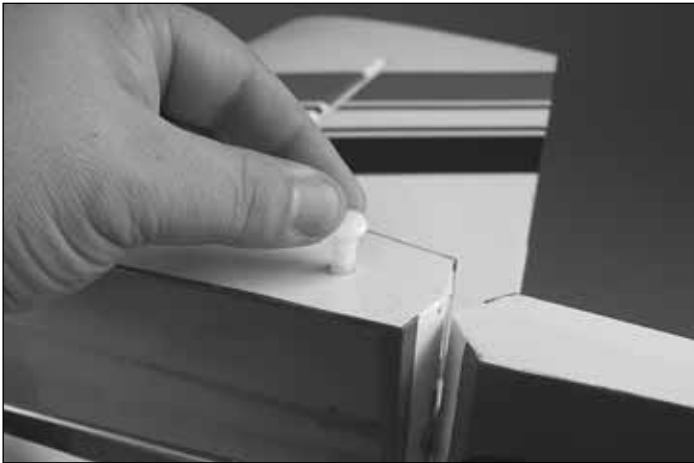

❑ 9. Glue the nylon tail gear bearing in this hole using a small amount of epoxy. Be careful not to let epoxy get inside the bearing.



❑ 10. Slide the large wheel collar onto the tail gear wire and insert it into the tail gear bearing.

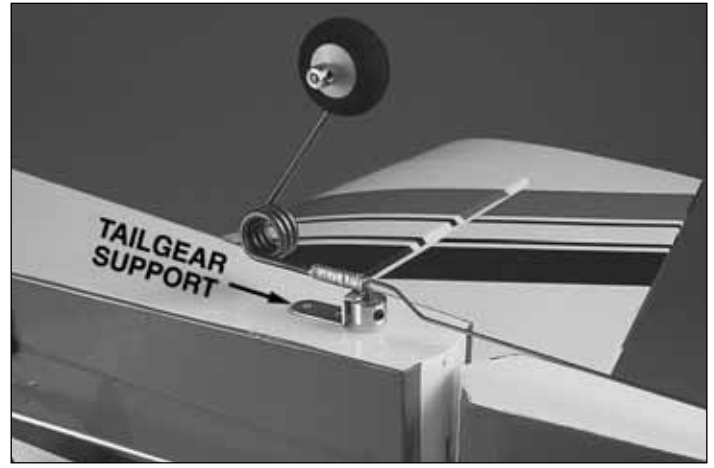

❑ 11. Slide the tail gear support into place as shown. Mark the location for the screw holes and drill 1/16" pilot holes at these marks. Attach the support to the fuselage using the supplied #2 x 1/4" [6 mm] screws. The height of the tail gear can be adjusted by loosening the set screw on the large wheel collar. The tail gear should not touch the top of the tail gear support when rotated. Lock the gear height in place using the wheel collar.



❑ 12. Slide the nylon rudder post onto the tail gear as shown. Move the post to the approximate midpoint of the gear wire. Be sure the rudder is centered and mark the location that the rudder post touches the rudder. Drill a 5/32" [4 mm] hole at this mark.

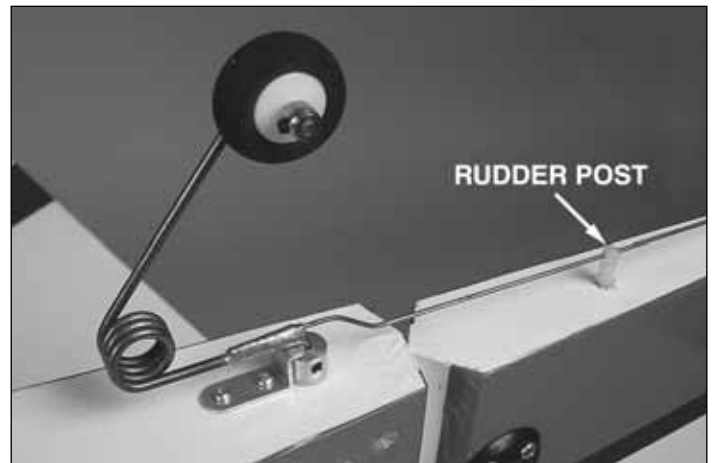

❑ 13. Glue the rudder post in place using a small amount of epoxy.

Glow Engine Installation

NOTE: If using a gas engine, please refer to *Optional Gas Engine Installation*.

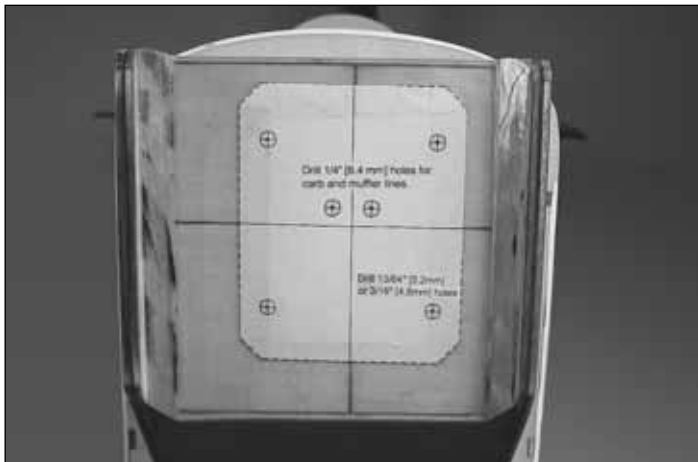

1. Cut the glow engine mount template from page 35. Use tape or spray adhesive to hold the template to the firewall. Align the vertical and horizontal lines on the template with the embossed lines on the firewall.

2. Use a large T-pin or a wire sharpened on the end to transfer the center of each bolt hole mark on the template into the firewall.

3. Drill through the holes on the template. The two holes in the center of the mount template are for your fuel lines to exit the firewall.

4. Mix a small amount of 30-minute epoxy. Apply a few dabs of epoxy to the front of four 8-32 blind nuts. Hold the blind nut against the back of the firewall and thread an 8-32 x 1-1/4" [32 mm] bolt with a #8 washer into the blind nut. Tighten the bolt to draw the blind nut into the wood. Be careful to avoid getting excess epoxy into the threads on the blind nuts.



5. Mount the engine mount to the firewall as shown using four 8-32 x 1-1/4" [32 mm] SHCS, #8 flat washers and #8 lock washers.

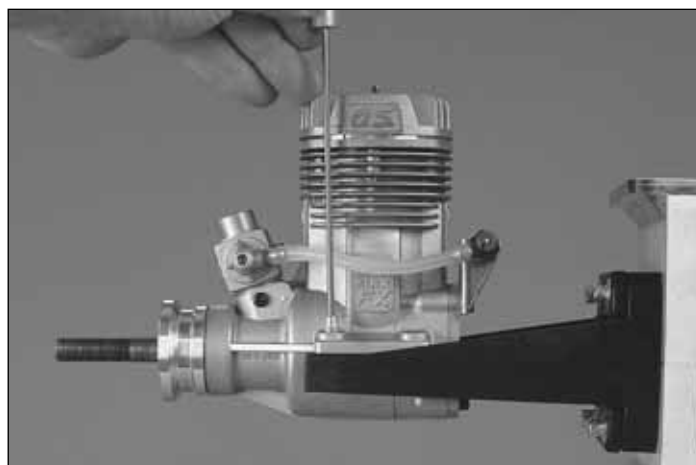
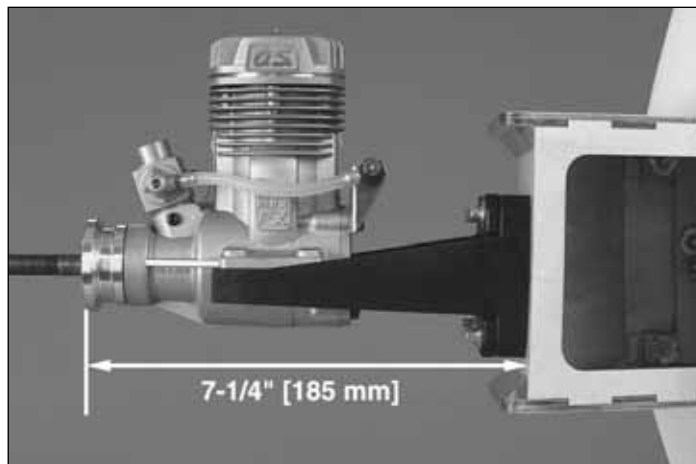

6. Place the engine in the mount. The distance from the firewall to the front of the drive washer is 7-1/4" [184 mm]. Use a Great Planes Engine Hole Locator or a small drill bit to mark the engine mounting holes into the engine mounts.

7. Take the engine off the mount. Drill 9/64" [#29] holes at the marks. Use an 8-32 tap to cut threads into the holes.

8. Mount the engine to the mount with four 8-32 x 1" [25 mm] socket head cap screws, four #8 flat washers and #8 lock washers.

Install the Throttle Servo (Glow Engine)

1. Connect the throttle servo to a 12" [305 mm] servo extension. Secure the connection using heat shrink tubing.

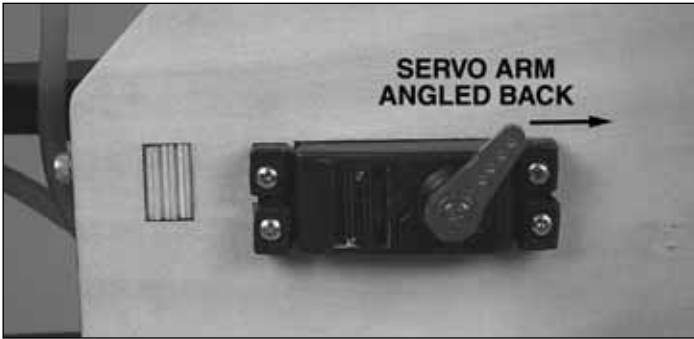

2. Insert the throttle servo into the firewall box and install a servo arm as shown. Drill 1/16" [1.6 mm] pilot holes for the servo mounting screws. Install the screws, then remove them. Harden the holes with thin CA. Allow the CA to fully dry before inserting the servo mounting screws.
3. Install the brass servo screw lock connector to the outer hole in the throttle servo arm.
4. If you have not already done so, install the muffler for your engine. This will allow you to route the throttle pushrod so it will clear the muffler.
5. Attach a **nylon clevis** and silicone retainer to the threaded end of the pushrod.

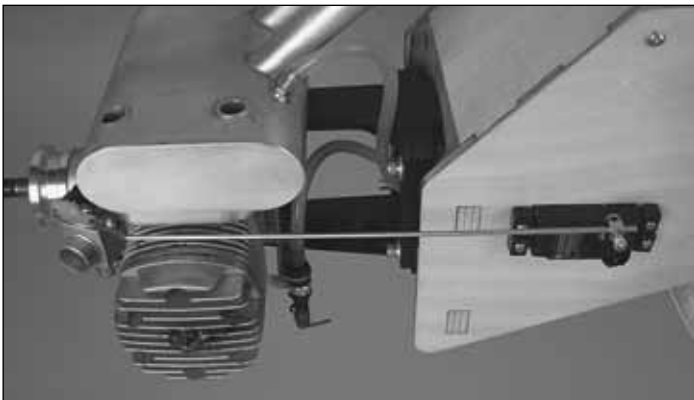

6. Bend the pushrod to allow it to clear the muffler and insert the throttle pushrod into the brass screw lock connector. Tighten the set screw to secure the rod.
7. Apply a drop of thread locker to the set screw to prevent it from backing out.
8. Using your radio system, adjust the throttle so that when the servo arm is facing the rear of the fuse as shown in the photo from step #2 the carburetor is fully open when your throttle stick is pushed all the way up. When the throttle stick and trim are moved all the way down, the carb should close completely. With the trim centered, there should be a gap of approximately 1/16" [1.6 mm] in the carb to allow the engine to idle.

Optional Gas Engine Installation

Note: The fuel line and stopper included in the Great Planes CAP 232 ARF are NOT gasoline safe. Gasoline will degrade the rubber stopper and silicone fuel tubing supplied. You will need to purchase a gasoline safe stopper and gasoline safe tubing to use for the fuel system on this model. The Sullivan #484 Gasoline/Diesel fuel tank conversion kit (SULQ2684) works well for this.

You will also need to purchase appropriate mounting hardware for your brand of engine. For the Fuji-Imvac 43cc gas engine installation, 10-32 or 1/4" hardware and blind nuts work best for mounting the engine to the firewall.

Because of the possibility of ignition engines creating radio noise, we use a plastic pushrod for the throttle servo installation. This isolates the engine and any radio noise from the servos. This is an IMPORTANT selection, and we cannot recommend strongly enough that you DO NOT change this pushrod to a metal pushrod. All radio equipment—including throttle servo, receiver battery, electronic kill switch, receiver on/off switch, and servo leads—should be mounted at least 12" [300 mm] away from anything related to the ignition/gasoline engine. Any material used between the engine and the radio equipment is STRONGLY recommended to be plastic, nylon, or otherwise non-metallic and nonconductive to minimize ignition noise transmission.

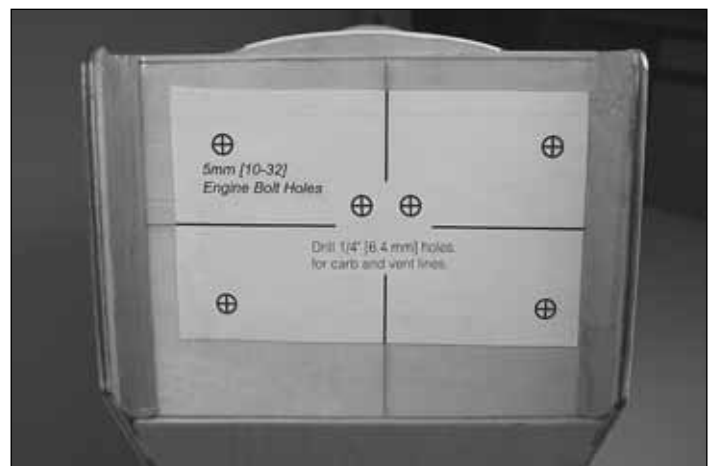

1. Cut the mounting bolt template for the Fuji-Imvac 43 Gas Engine from page 35 of this manual and tape it to the firewall. Align the vertical and horizontal lines as shown.
2. Drill 3/32" [2.5 mm] pilot holes at the center of the cross marks for the bolt holes.

Install the Throttle Servo (Gas Engine)



1. Install the throttle servo into the servo tray using the hardware provided by your servo's manufacturer. Choose the mounting position that gives you the most direct route to your carburetor. For the Fuji-Imvac 43cc gas engine, typically the servo location would be in the far right mounting position as shown.



2. Using a non-metallic flexible pushrod system, connect the throttle servo to the carburetor on your engine. Shown in the photo is the Semi-Flexible Pushrod system from Great Planes (GPMQ3714). This system comes with ideal components for this type of throttle connection. Since engine installations can vary, the location of the holes in the formers and firewall for the pushrod to route through will also vary. For our installation of the Fuji-Imvac 43cc gas engine, the throttle pushrod was routed along the right side of the fuselage as shown.



3. Remove the template and enlarge the holes using a 1/4" [6 mm] drill bit.

4. Mix a small amount of 30-minute epoxy. Apply a few dabs of epoxy to the front of four 10-32 or 1/4" blind nuts (not included). Hold the blind nut against the back of the firewall and thread a 10-32 or 1/4" bolt (not included) with a washer into the blind nut. Tighten the bolt to draw the blind nut into the wood. Be careful to avoid getting excess epoxy into the threads on the blind nuts.

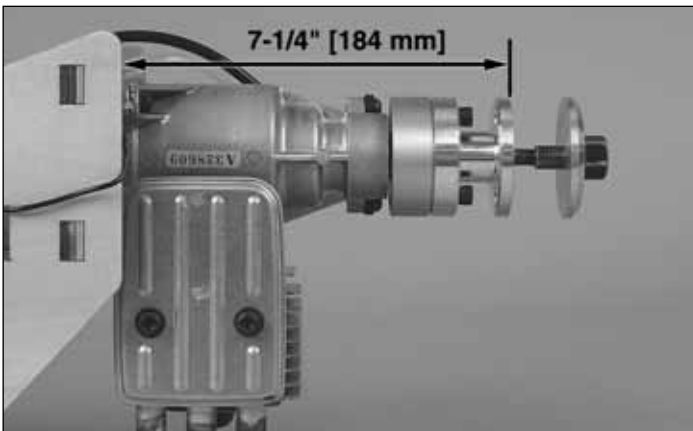

5. Mount the engine to the firewall so that the distance from the firewall to the drive washer is 7-1/4" [184 mm].



6. Mount the electronic ignition unit as shown.

7. Following the guidelines in the shaded box previously shown, install an ignition kill switch into the fuselage.

Gas Stopper Assembly

1. Remove the stopper from the included fuel tank and replace it with a gas safe stopper such as the Sullivan #484 (SULQ2684) or Dubro #400 (DUBQ0675).



2. Assemble the stopper using Du-Bro #813 1/8" [3.2 mm] I.D. fuel line bars (DUBQ0670) and 1/8" [3.2 mm] brass tubing as shown. Solder the bars to the brass tubing but be careful not to overheat the assembly as it could cause damage to the rubber stopper.

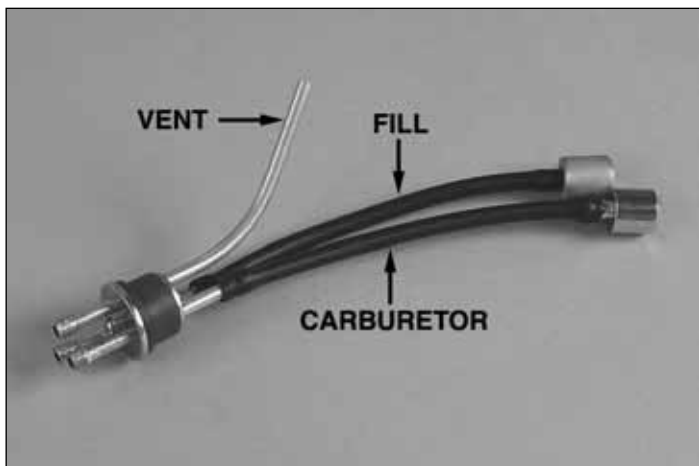

3. Attach gasoline safe fuel line with clunks to the tubing as shown; remember to bend the vent line upwards towards the top of the fuel tank. The clunks should move freely. One clunk is for the fill line and one is for the carburetor line.

Glow Stopper Assembly

1. Locate the **fuel tank**. The hardware needed for the fuel tank assembly is inside of the tank. Remove the stopper and shake out the contents.
2. The fuel system for the CAP 232 uses three lines. There is a fill line, carb line, and vent line (to muffler). The fill line will allow fueling without removing the cowl.

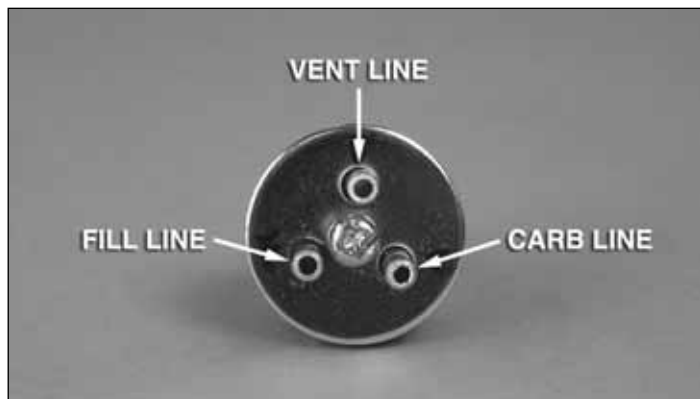

3. Slide the three aluminum fuel tubes into the rubber stopper as shown.

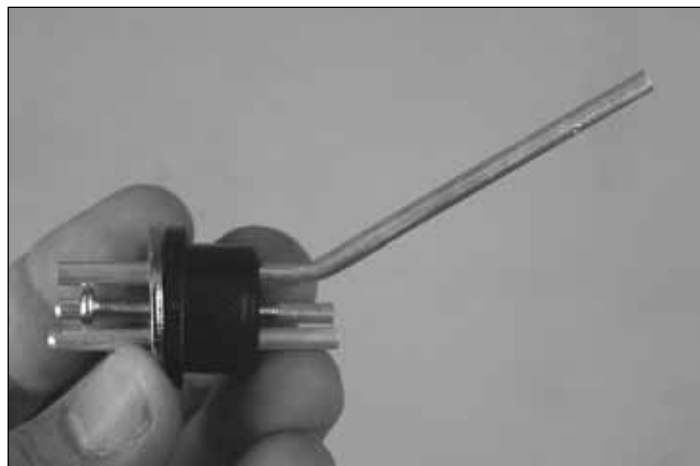

4. Cut the fill line and carb line tubes so that the tubes extend 1/2" [13 mm] out from both ends of the stopper. The vent line should be bent upwards and left uncut.

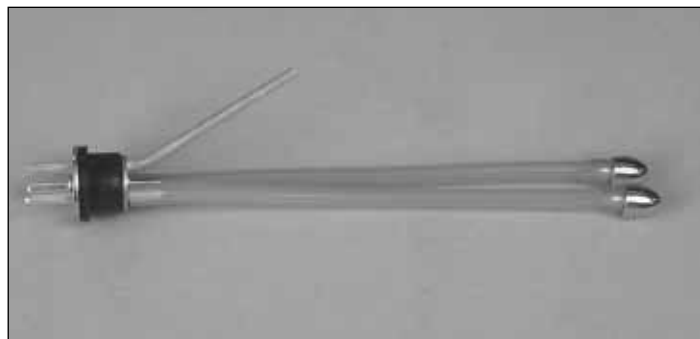

5. Attach silicone fuel lines 6" [153 mm] in length to the fill and carb tubes on the stopper. Install fuel clunks on each of these lines.

Install the Fuel Tank

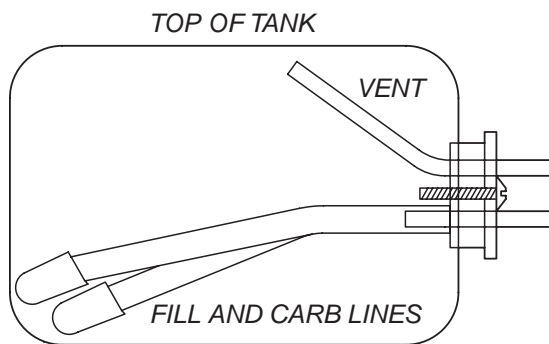

1. Insert the stopper and check the length of the fuel line and fill lines. The clunks should rest almost against the back of the tank when the stopper is in place but move freely inside the tank. Adjust the length of the fuel line until the proper length has been reached. Once you are satisfied with the fit, secure the stopper using the Phillips head screw in the stopper assembly. Be careful not to over tighten the stopper.



2. Insert the tank at a slight downward angle as shown in the first photo. Then level it out and slide it forward until the stopper assembly enters the cutout for it in the first former. When fully in place, it should rest as shown in the second photo.



3. Cut two small strips of 1/4" [6.4 mm] foam (not included) approximately 1/2" [13 mm] wide. Insert these strips between the fuel tank and the former. Glue them in place using CA. Begin with the bottom piece of foam. You may need to temporarily remove the tank to glue in the bottom foam.

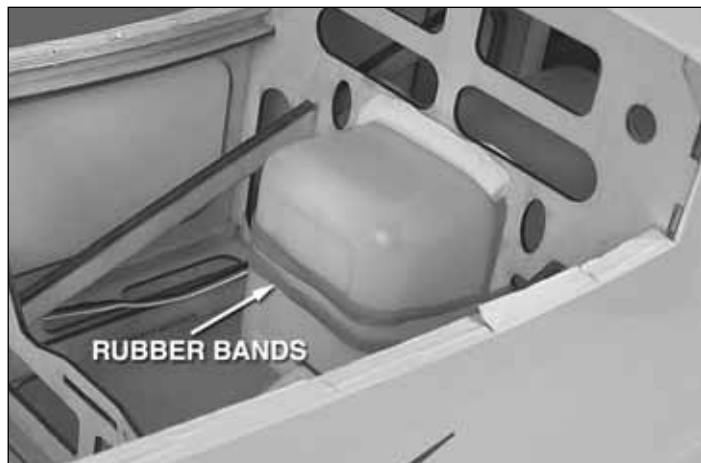

4. Secure the tank using the supplied rubber bands.
5. Attach fuel line from each tube on the stopper to the carburetor, muffler (vent for gasoline engines) and fill line. Route the carburetor and muffler (vent) lines through the holes you drilled in the firewall.

Install the Cowl

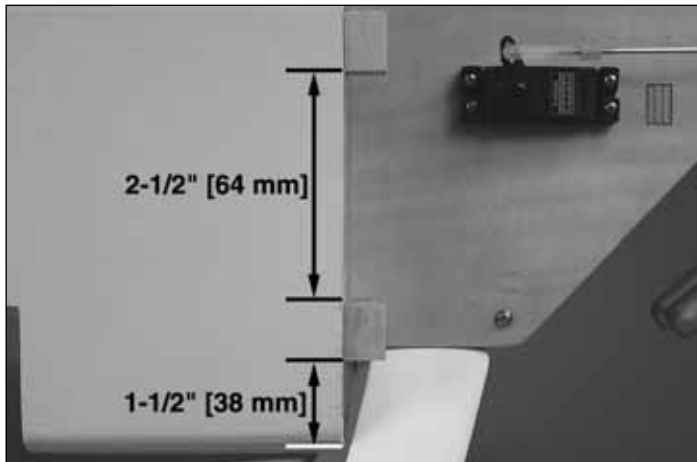

1. Using 30 minute epoxy, glue a hardwood cowl mounting block flush with the side of the fuselage. Position the first block 1-1/2" [38 mm] from the bottom of the fuselage as shown. Remove the epoxy in the area where the block will mount with some medium grit sandpaper (220 grit works good for this) so that the epoxy will adhere better. Position the next block 2-1/2" [64 mm] from the top of the first block as shown and epoxy in place. Be sure to remove the epoxy in the areas on the firewall for all blocks prior to epoxying in place.



3. The two remaining hardwood blocks are glued on the top of the fuse as shown. Evenly space them apart. The exact location is not important.

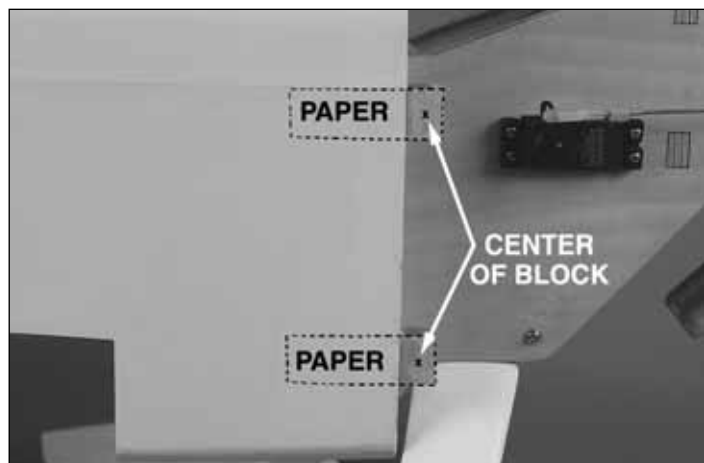

4. Mark the center of each hardwood block. From this mark, run a 2" [51 mm] piece of paper straight back onto the fuselage to use as templates.

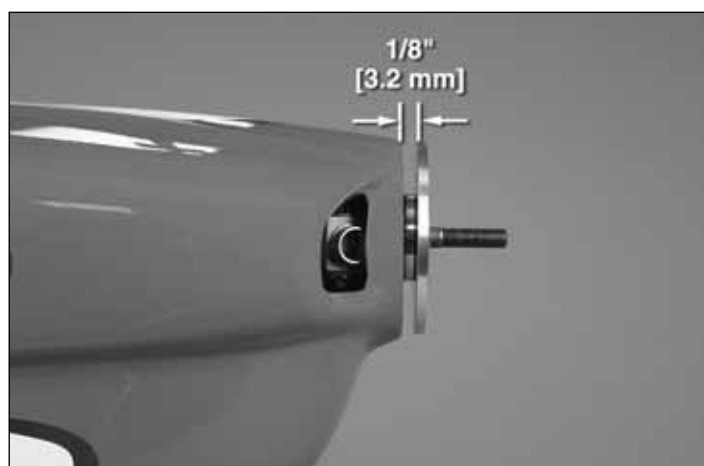

5. Slide the cowl over the engine and onto the fuselage. Use a Dremel tool with a cutting bit to trim the cowl if necessary so you can get it to fit over the engine. Mount the spinner back plate to the engine. Position the cowl so that there is a 1/8" [3.2 mm] gap between the cowl and the spinner back plate.

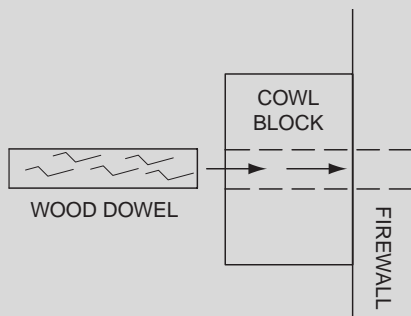

For added strength, after the cowl mounting blocks are all securely epoxyed in place, drill 1/8" [3.2 mm] holes through the center of each block into the firewall. Insert an appropriate length of 1/8" [3.2 mm] wooden dowel (not included) into this hole and into the firewall. Glue this in place using thin CA. This modification is especially useful for high vibration engines.

2. Glue two more hardwood blocks on the other side of the fuse at the same locations.

❑ 6. Hold the cowl in place with masking tape, or have a friend help you by holding it in place. Slide the cowl underneath the paper templates and mark the location of the center of the blocks on the cowl.

❑ 7. Drill 3/32" [2.4 mm] pilot holes through the cowl and into the mounting blocks. Remove the cowl and enlarge the holes in the cowl using a 7/64" [2.8 mm] drill bit. This will prevent the cowl from splitting when the cowl screws are installed.



❑ 8. Attach the cowl using six #4 x 1/2" [13 mm] screws and #4 flat washers. Be sure to harden the holes in the blocks with thin CA.



❑ 9. Once you have the cowl attached and aligned, make any necessary cutouts to access engine tuning screws, or

adjustments such as needle valves. Also make a cutout for the exhaust to clear the cowling. Shown in the photos are the cutouts we made for the OS 1.60 FX installation. Your cutouts may vary depending on the engine of choice.

Attach the Canopy



❑ Attach the canopy to the fuselage using **four #2 x3/8" [9.5 mm] screws** and **#2 flat washers**. There are wooden reinforcement pieces on the inside edge of the cockpit area for the screws. If you wish to install a pilot figure (not included), you should do so now. This is also a good time to paint the interior cockpit area if desired.

Mount the Spinner



❑ 1. When using the spinner on a gasoline engine, there is a small brass bushing that will need to be inserted into the spinner back plate before mounting the spinner.

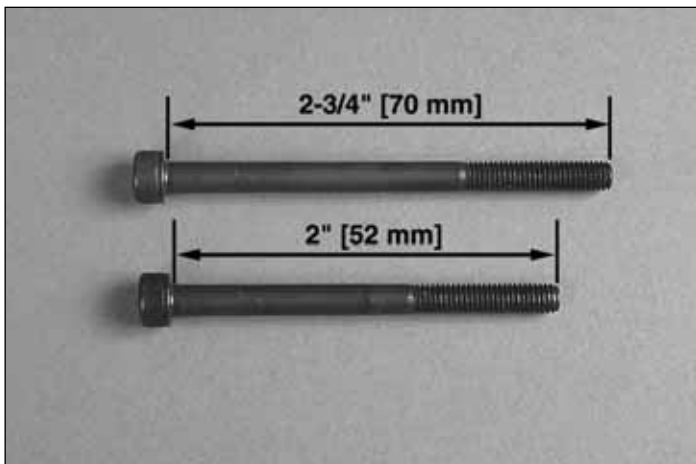

❑ 2. For a glow engine installation, you will need to use the spinner jam nut that is included with the spinner. It is tightened against the prop nut and washer as shown. It is pre-tapped to accept the spinner bolts. Two lengths of spinner bolts are included with the spinner. Depending on your prop selection and engine selection, you will need to choose which bolt is the best length for your needs. It may also be necessary to trim the length of the bolt to fit your installation. If so, prior to cutting the bolt to length, thread the provided 5 mm nut onto the bolt. After trimming to the desired length, back the nut off of the bolt to clean the threads.



❑ 3. Mount the spinner cone to the back plate using one of the supplied spinner bolts

Route the Antenna



❑ There is a pre-installed antenna tube in the fuselage of your CAP 232. Gently thread the antenna completely into this tube prior to flight.

Apply the Decals

1. Use scissors or a sharp hobby knife to cut the decals from the sheet.

2. Be certain the model is clean and free from oily fingerprints and dust. Prepare a dishpan or small bucket with a mixture of liquid dish soap and warm water—about one teaspoon of soap per gallon of water. Submerge the decal in the soap and water and peel off the paper backing. **Note:** Even though the decals have a “sticky-back” and are not the water transfer type, submersing them in soap & water allows accurate positioning and reduces air bubbles underneath.

3. Position decal on the model where desired. Holding the decal down, use a paper towel to wipe most of the water away.

4. Use a piece of soft balsa or something similar to squeegee remaining water from under the decal. Apply the rest of the decals the same way.

GET THE MODEL READY TO FLY

Check the Control Directions

☐ 1. Turn on the transmitter and receiver and center the trims. If necessary, remove the servo arms from the servos and reposition them so they are centered. Reinstall the screws that hold on the servo arms.

☐ 2. With the transmitter and receiver still on, check all the control surfaces to see if they are centered. If necessary, adjust the clevises on the pushrods to center the control surfaces.

4-CHANNEL RADIO SETUP (STANDARD MODE 2)

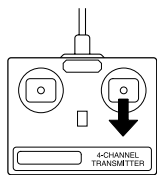

ELEVATOR MOVES UP

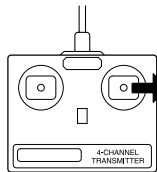

RIGHT AILERON MOVES UP
LEFT AILERON MOVES DOWN

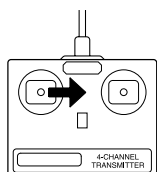

RUDDER MOVES RIGHT
NOSE WHEEL TURNS RIGHT

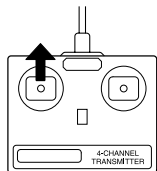

CARBURETOR WIDE OPEN

☐ 3. Make certain that the control surfaces and the carburetor respond in the correct direction as shown in the diagram. If any of the controls respond in the wrong direction, use the servo reversing in the transmitter to reverse the servos connected to those controls. Be certain the control surfaces have remained centered. Adjust if necessary.

Set the Control Throws

Due to the size of the control surfaces on the Great Planes CAP 232, use of a Great Planes AccuThrow is not possible for measuring throws. A ruler should be used to accurately measure and set the control throw of each control surface as indicated in the chart that follows.

NOTE: The throws are measured at the widest part of the elevators, rudder and ailerons.

These are the recommended control surface throws:

	High Rate	Low Rate
ELEVATOR:	2-1/2" [64 mm] up 2-1/2" [64 mm] down	1-1/2" [38 mm] up 1-1/2" [38 mm] down
AILERONS:	1-1/2" [38 mm] up 1-1/2" [38 mm] down	1" [25 mm] up 1" [25 mm] down
RUDDER:	4-1/2" [114 mm] right 4-1/2" [114 mm] left	3" [76 mm] right 3" [76 mm] left

3D RATES:

ELEVATOR:	4" [102 mm] up 4" [102 mm] down
AILERONS:	3" [76 mm] up 3" [76 mm] down
RUDDER:	6" [153 mm] right 6" [153 mm] left

IMPORTANT: The Great Planes CAP 232 ARF has been **extensively** flown and tested to arrive at the throws at which it flies best. Flying your model at these throws will provide you with the greatest chance for successful first flights. If, after you have become accustomed to the way the Great Planes CAP 232 ARF flies, you would like to change the throws to suit your taste, that is fine. However, too much control throw could make the model difficult to control, so remember, "More is not always better."

Note: In order to achieve the full 3D rates noted in the chart above, you will need to purchase longer servo arms for the aileron and elevator servos. A total of four long servo arms will be needed. We recommend using the Great Planes Aluminum servo arms listed below:

- Large-scale 1" [25 mm] single-sided servo arm (GPMM1100)
- Large-scale 1.5" [38 mm] single-sided servo arm (GPMM1105)

Balance the Model (C.G.)

More than any other factor, the **C.G.** (balance point) can have the **greatest** effect on how a model flies, and may determine whether or not your first flight will be successful. If you value this model and wish to enjoy it for many flights, **DO NOT OVERLOOK THIS IMPORTANT PROCEDURE.** A model that is not properly balanced will be unstable and possibly unflyable.

At this stage the model should be in ready-to-fly condition with all of the systems in place including the engine, landing gear, covering and paint, and the radio system.

1. Use a felt-tip pen or 1/8" [3 mm]-wide tape to accurately mark the C.G. on the top of the wing on both sides of the fuselage. The C.G. is located 5-3/4" [146 mm] back from the leading edge of the wing.

This is where your model should balance for the first flights. Later, you may wish to experiment by shifting the C.G. up to 3/4" [19 mm] forward or 3/4" [19 mm] back to change the flying characteristics. Moving the C.G. forward may improve the smoothness and stability, but the model may then require more speed for takeoff and make it more difficult to slow for landing. Moving the C.G. aft makes the model more maneuverable, but could also cause it to become too difficult to control. In any case, **start at the recommended balance point** and do not at any time balance the model outside the specified range.

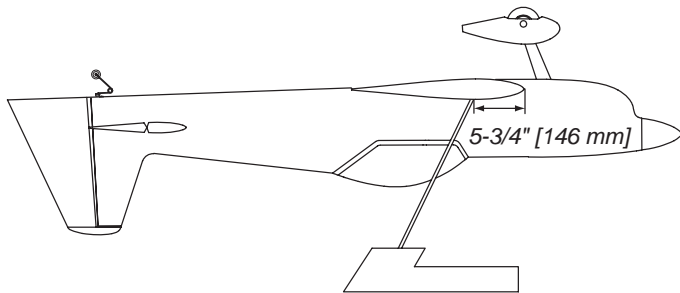

2. With the wing attached to the fuselage, all parts of the model installed (ready to fly) and an empty fuel tank, place the model upside-down on a Great Planes CG Machine, or lift it upside down at the balance point you marked.

3. If the tail drops, the model is "tail heavy" and the battery pack and/or receiver must be shifted forward or weight must be added to the nose to balance. If the nose drops, the model is "nose heavy" and the battery pack and/or receiver must be shifted aft or weight must be added to the tail to balance. **If possible, relocate the battery pack and receiver to minimize or eliminate any additional ballast required.** If additional weight is required, nose weight may be easily added by using Great Planes (GPMQ4485) "stick on" lead. A good place to add stick-on nose weight is to the firewall box (don't attach weight to the cowl-it is not intended to support weight). Begin by placing

incrementally increasing amounts of weight on the firewall box until the model balances. Once you have determined the amount of weight required, it can be permanently attached. If required, tail weight may be added by cutting open the bottom of the fuse and gluing it permanently inside.

Note: Do not rely upon the adhesive on the back of the lead weight to permanently hold it in place. Over time, fuel and exhaust residue may soften the adhesive and cause the weight to fall off. Use #2 sheet metal screws, RTV silicone or epoxy to permanently hold the weight in place.

4. **IMPORTANT:** If you found it necessary to add any weight, recheck the C.G. after the weight has been installed.

Balance the Model Laterally

1. With the wing level, have an assistant help you lift the model by the engine propeller shaft and the bottom of the fuse under the TE of the fin. Do this several times.

2. If one wing always drops when you lift the model, it means that side is heavy. Balance the airplane by adding weight to the other wing tip. **An airplane that has been laterally balanced will track better in loops and other maneuvers.**

PREFLIGHT

Identify Your Model

No matter if you fly at an AMA sanctioned R/C club site or if you fly somewhere on your own, you should always have your name, address, telephone number and AMA number on or inside your model. It is **required** at all AMA R/C club flying sites and AMA sanctioned flying events. Fill out the identification tag on the last page of this manual and place it on or inside your model.

Charge the Batteries

Follow the battery charging instructions that came with your radio control system to charge the batteries. You should always charge your transmitter and receiver batteries the night before you go flying, and at other times as recommended by the radio manufacturer.

CAUTION: Unless the instructions that came with your radio system state differently, the **initial** charge on **new** transmitter and receiver batteries should be done for 15 hours **using the slow-charger that came with the radio system.** This will "condition" the batteries so that the next charge may be done using the fast-charger of your choice. If the initial charge is done with a fast-charger the batteries may not reach their full capacity and you may be flying with batteries that are only partially charged.

Balance Propellers

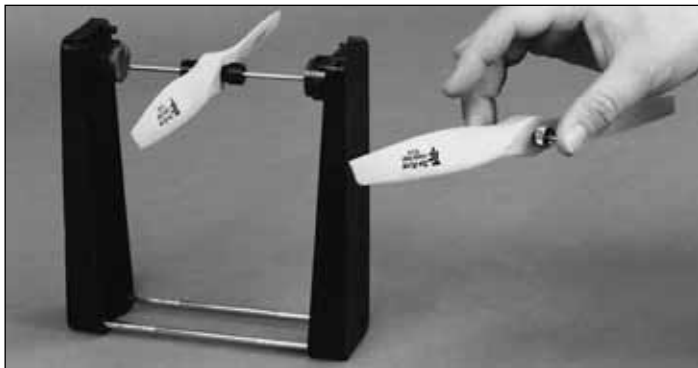

Carefully balance your propeller and spare propellers before you fly. An unbalanced prop can be the single most significant cause of vibration that can damage your model. Not only will engine mounting screws and bolts loosen, possibly with disastrous effect, but vibration may also damage your radio receiver and battery. Vibration can also cause your fuel to foam, which will, in turn, cause your engine to run hot or quit.

We use a Top Flite Precision Magnetic Prop Balancer™ (TOPQ5700) in the workshop and keep a Great Planes Fingertip Prop Balancer (GPMQ5000) in our flight box.

Ground Check

If the engine is new, follow the engine manufacturer's instructions to break-in the engine. After break-in, confirm that the engine idles reliably, transitions smoothly and rapidly to full power and maintains full power indefinitely. After you run the engine on the model, inspect the model closely to make sure all screws remained tight, the hinges are secure, the prop is secure and all pushrods and connectors are secure.

Range Check

Ground check the operational range of your radio before the first flight of the day. With the transmitter antenna collapsed and the receiver and transmitter on, you should be able to walk at least 100 feet away from the model and still have control. Have an assistant stand by your model and, while you work the controls, tell you what the control surfaces are doing. Repeat this test **with the engine running** at various speeds with an assistant holding the model, using hand signals to show you what is happening. If the control surfaces do not respond correctly, **do not fly!** Find and correct the problem first. Look for loose servo connections or broken wires, corroded wires on old servo connectors, poor solder joints in your battery pack or a defective cell, or a damaged receiver crystal from a previous crash.

ENGINE SAFETY PRECAUTIONS

Failure to follow these safety precautions may result in severe injury to yourself and others.

- Keep all engine fuel in a safe place, away from high heat, sparks or flames, as fuel is very flammable. Do not smoke near the engine or fuel; and remember that engine exhaust gives off a great deal of deadly carbon monoxide. Therefore **do not run the engine in a closed room or garage.**
- Get help from an experienced pilot when learning to operate engines.
- Use safety glasses when starting or running engines.
- Do not run the engine in an area of loose gravel or sand; the propeller may throw such material in your face or eyes.
- Keep your face and body as well as all spectators away from the plane of rotation of the propeller as you start and run the engine.
- Keep these items away from the prop: loose clothing, shirt sleeves, ties, scarves, long hair or loose objects such as pencils or screwdrivers that may fall out of shirt or jacket pockets into the prop.
- Use a "chicken stick" or electric starter to start the engine. Do not use your fingers to flip the propeller. Make certain the glow plug clip on glow engines or spark plug connector on gas engines is secure so that it will not pop off or otherwise get into the running propeller.
- Make all engine adjustments from behind the rotating propeller.
- The engine gets hot! Do not touch it during or right after operation. Make sure fuel lines are in good condition so fuel will not leak onto a hot engine, causing a fire.
- To stop a glow engine, cut off the fuel supply by closing off the fuel line or following the engine manufacturer's recommendations. Do not use hands, fingers or any other body part to try to stop the engine. To stop a gasoline powered engine an on/off switch should be connected to the engine coil. Do not throw anything into the propeller of a running engine.

AMA SAFETY CODE (EXCERPTS)

Read and abide by the following excerpts from the Academy of Model Aeronautics Safety Code. For the complete Safety Code refer to *Model Aviation* magazine, the AMA web site or the Code that came with your AMA license.

General

- 1) I will not fly my model aircraft in sanctioned events, air shows, or model flying demonstrations until it has been proven to be airworthy by having been previously, successfully flight tested.
- 2) I will not fly my model aircraft higher than approximately 400 feet within 3 miles of an airport without notifying the airport operator. I will give right-of-way and avoid flying in the proximity of full-scale aircraft. Where necessary, an observer shall be utilized to supervise flying to avoid having models fly in the proximity of full-scale aircraft.
- 3) Where established, I will abide by the safety rules for the flying site I use, and I will not willfully and deliberately fly my models in a careless, reckless and/or dangerous manner.
- 5) I will not fly my model unless it is identified with my name and address or AMA number, on or in the model. Note: This does not apply to models while being flown indoors.
- 7) I will not operate models with pyrotechnics (any device that explodes, burns, or propels a projectile of any kind).

Radio Control

- 1) I will have completed a successful radio equipment ground check before the first flight of a new or repaired model.
- 2) I will not fly my model aircraft in the presence of spectators until I become a qualified flier, unless assisted by an experienced helper.
- 3) At all flying sites a straight or curved line(s) must be established in front of which all flying takes place with the other side for spectators. Only personnel involved with flying the aircraft are allowed at or in the front of the flight line. Intentional flying behind the flight line is prohibited.
- 4) I will operate my model using only radio control frequencies currently allowed by the Federal Communications Commission.
- 5) **I will not knowingly operate my model within three miles of any pre-existing flying site except in accordance with the frequency sharing agreement listed** [in the complete AMA Safety Code].
- 9) Under no circumstances may a pilot or other person touch a powered model in flight; **nor should any part of the model other than the landing gear intentionally touch the ground, except while landing.**

IMAA SAFETY CODE (EXCERPTS)

Since the Great Planes CAP 232 ARF qualifies as a "giant scale" model and is therefore eligible to fly in IMAA events, we've printed excerpts from the IMAA Safety Code which follows.

Definition:

For the purpose of the following IMAA Safety Code, the term Giant Scale shall refer to radio controlled model aircraft, either scale or non-scale, which have a wingspan of 80 inches or more for monoplanes and 60 inches or more for multi-winged model aircraft and have a ramp weight (fueled and ready to fly) of 55 lbs. or less.

Section 1.0: SAFETY STANDARD

- 1.1 Adherence to Code: This safety code is to be strictly followed.
- 1.2 The most current AMA Safety Code in effect is to be observed. However, the competition sections of the code may be disregarded.

Section 3.0: SAFETY CHECK

- 3.4 Flight Testing: All Giant Scale R/C aircraft are to have been flight tested and flight trimmed with a minimum of six flights before the model is allowed to fly at an IMAA Sanctioned event.
- 3.5 Proof of Flight: The completing and signing of the Declaration section of the Safety Inspection form by the pilot (or owner) shall document as fact that each aircraft has been successfully flight-tested and proven airworthy prior to an IMAA event.

Section 5.0: EMERGENCY ENGINE SHUT OFF (Kill Switch)

- 5.1 All magneto spark ignition engines must have a coil grounding switch on the aircraft to stop the engine. This will also prevent accidental starting of the engine. This switch shall be readily available to both pilot and helper. This switch is to be operated manually and without the use of the radio system.
- 5.2 Engines with battery power ignition systems must have a switch to turn off the power from the battery pack to disable the engine from firing. This will also prevent accidental starting of the engine. This switch shall be readily available to both pilot and helper. This switch shall be operated manually and without the use of the Radio System.
- 5.3 There must also be a means to stop the engine from the transmitter. The most common method is to close the carburetor throat completely using throttle trim, however, other methods are acceptable. This requirement applies to all glow/gas ignition engines regardless of size.

Section 6.0: RADIO REQUIREMENTS

- 6.1 All transmitters must be FCC type certified.
- 6.2 FCC Technician or higher-class license required for 6 meter band operation only.

ADDITIONAL IMAA GENERAL RECOMMENDATIONS

The following recommendations are included in the Safety Code not to police such items, but rather to offer basic suggestions for enhanced safety.

- Servos need to be of a rating capable to handle the loads that the control surfaces impose upon the servos. Standard servos are not recommended for control surfaces. Servos should be rated heavy-duty. For flight-critical control functions a minimum of 45 inch/ounces of torque should be considered. This should be considered a minimum for smaller aircraft and higher torque servos are strongly encouraged for larger aircraft. The use of one servo for each aileron and one for each elevator half is strongly recommended. Use of dual servos is also recommended for larger aircraft.
- On-board batteries shall be 1000 mAh up to 20 lbs., 1200 mAh to 30 lbs., 1800 mAh to 40 lbs. and 2000 mAh over 40 lbs. flying weight. The number and size of servos, size and loads on control surfaces, and added features should be considered as an increase to these minimums. Batteries should be able to sustain power to the onboard radio components for a minimum of one hour total flying time before recharging.
- Redundant and fail-safe battery systems are recommended.
- The use of anti-glitch devices for long leads is recommended.
- There is no maximum engine displacement limit, as it is the position of this body that an underpowered aircraft presents a greater danger than an overpowered aircraft. However, the selection of engine size relative to airframe strength and power loading mandates good discretionary judgment by the designer and builder. Current AMA maximums for engine displacement are 6.0 cu. in. for two-stroke and 9.6 cu. in. for four-stroke engines. These maximums apply only to AMA Sanctions concerning competition events (such as 511, 512, 515 and 520) and, as such, the maximums apply. All IMAA (non competition) events should be sanctioned as Class "C" events, in which these engine size maximums do not apply.
- Generally, it is recommended that no attempt should be made to fly a radio controlled model aircraft with a gasoline engine in which the model aircraft weight would exceed twelve (12) pounds (underpowered) per cubic inch of engine displacement, or be less than five (5) pounds (overpowered) per cubic inch of engine displacement. Example: Using a 3 cu. in. engine, a model would likely be underpowered at an aircraft weight greater than 36 pounds. With the same engine, an aircraft weighing less than 15 pounds would likely be overpowered.
- Servo arms and wheels should be rated heavy duty. Glass-filled servo arms and control horns are highly recommended.
- Control surface linkages are listed in order of preference:
 1. Cable system (pull-pull). A tiller bar is highly recommended along with necessary bracing.

2. Arrow-shaft, fiberglass or aluminum, 1/4" or 5/16" OD. Bracing every six (6) to ten (10) inches is highly recommended.
3. Tube-in-tube (Nyrod). Bracing every few inches is highly recommended. Inner tube should be totally enclosed in outer tube.
4. Hardwood dowel, 3/8" OD. Bracing every six (6) to ten (10) inches is highly recommended.

- Hinges should be rated heavy duty and manufactured for Giant Scale use primarily. Homemade and original design hinges are acceptable if determined to be adequate for the intended use.
- Clevis (steel, excluding heavy-duty ball links) and attachment hardware should be heavy duty 4-40 threaded rod type. 2-56 threaded size rod is acceptable for some applications (e.g. throttle). Clevis is to have lock nuts and sleeve or spring keepers.
- Propeller tips should be painted or colored in a visible and contrasting manner so as to increase the visibility of the propeller tip arc.

CHECK LIST

During the last few moments of preparation your mind may be elsewhere anticipating the excitement of the first flight. Because of this, you may be more likely to overlook certain checks and procedures that should be performed before the model is flown. To help avoid this, a check list is provided to make sure these important areas are not overlooked. Many are covered in the instruction manual, so where appropriate, refer to the manual for complete instructions. Be sure to check the items off as they are completed.

- 1. Fuel proof all areas exposed to fuel or exhaust residue such as the cowl ring, cowl mounting blocks, wing saddle area, etc.
- 2. Check the C.G. according to the measurements provided in the manual.
- 3. Be certain the battery and receiver are securely mounted in the fuse. Simply stuffing them into place with foam rubber is not sufficient.
- 4. Extend your receiver antenna and make sure it has a strain relief inside the fuselage to keep tension off the solder joint inside the receiver.
- 5. Balance your model *laterally* as explained in the instructions.
- 6. Use thread locking compound to secure critical fasteners such as the set screws that hold the wheel axles to the struts, screws that hold the carburetor arm (if applicable), screw-lock pushrod connectors, etc.
- 7. Add a drop of oil to the axles so the wheels will turn freely.
- 8. Make sure all hinges are **securely** glued in place.

- 9. Reinforce holes for wood screws with thin CA where appropriate (servo mounting screws, cowl mounting screws, etc.).
- 10. Confirm that all controls operate in the correct direction and the throws are set up according to the manual.
- 11. Make sure there are silicone retainers on all the clevises and that all servo arms are secured to the servos with the screws included with your radio.
- 12. Secure connections between servo wires and Y-connectors or servo extensions, and the connection between your battery pack and the on/off switch with vinyl tape, heat shrink tubing or special clips suitable for that purpose.
- 13. Make sure any servo extension cords you may have used do not interfere with other systems (servo arms, pushrods, etc.).
- 14. Secure the pressure tap (if used) to the muffler with high temp RTV silicone, thread locking compound or J.B. Weld.
- 15. Make sure the fuel lines are connected and are not kinked.
- 16. Balance your propeller (and spare propellers).
- 17. Tighten the propeller nut and spinner.
- 18. Place your name, address, AMA number and telephone number on or inside your model.
- 19. Cycle your receiver battery pack (if necessary) and make sure it is fully charged.
- 20. If you wish to photograph your model, do so before your first flight.
- 21. Range check your radio when you get to the flying field.

FLYING

CAUTION (THIS APPLIES TO ALL R/C AIRPLANES): If, while flying, you notice an alarming or unusual sound such as a low-pitched “buzz,” this may indicate control surface flutter. Flutter occurs when a control surface (such as an aileron or elevator) or a flying surface (such as a wing or stab) rapidly vibrates up and down (thus causing the noise). In extreme cases, if not detected immediately, flutter can actually cause the control surface to detach or the flying surface to fail, thus causing loss of control followed by an impending crash. The best thing to do when flutter is detected is to slow the model **immediately** by reducing power, then land as soon as safely possible. Identify which surface fluttered (so the problem may be resolved) by checking all the servo grommets for deterioration or signs of vibration. Make certain all pushrod linkages are secure and free of play. If it fluttered once, under similar circumstances it will probably flutter again unless the problem is fixed. Some things which can cause flutter are; Excessive hinge gap; Not mounting control horns solidly; Poor fit of clevis pin in horn; Side-play of wire pushrods caused by large bends; Excessive free play in servo gears; Insecure servo mounting; and one of the most prevalent causes of flutter; Flying an over-powered model at excessive speeds.

The Great Planes CAP 232 ARF is a great-flying model that flies smoothly and predictably. The Great Planes CAP 232 ARF does not, however, possess the self-recovery characteristics of a primary R/C trainer and should be flown only by experienced R/C pilots.

Fuel Mixture Adjustments

A fully cowled engine may run at a higher temperature than an un-cowled engine. For this reason, the fuel mixture should be richened so the engine runs at about 200 rpm below peak speed. By running the engine slightly rich, you will help prevent dead-stick landings caused by overheating.

Takeoff

Before you get ready to takeoff, see how the model handles on the ground by doing a few practice runs at **low speeds** on the runway. Hold “up” elevator to keep the tail wheel on the ground. If necessary, adjust the tail wheel so the model will roll straight down the runway. If you need to calm your nerves before the maiden flight, shut the engine down and bring the model back into the pits. Top off the fuel, and then check all fasteners and control linkages for peace of mind.

Remember to takeoff into the wind. When you’re ready, point the model straight down the runway, hold a bit of up elevator to keep the tail on the ground to maintain tail wheel steering, and then gradually advance the throttle. As the model gains speed decrease up elevator, allowing the tail to come off the ground. One of the most important things to remember with a tail dragger is to always be ready to apply **right** rudder to counteract engine torque. Gain as much speed as your runway and flying site will practically allow before gently applying up elevator, lifting the model into the air. At this moment it is likely that you will need to apply more right rudder to counteract engine torque. Be smooth on the elevator stick, allowing the model to establish a gentle climb to a safe altitude before turning into the traffic pattern.

Flight

For reassurance and to keep an eye on other traffic, it is a good idea to have an assistant on the flight line with you. Tell him to remind you to throttle back once the plane gets to a comfortable altitude. While full throttle is usually desirable for takeoff, most models fly more smoothly at reduced speeds.

Take it easy with the Great Planes CAP 232 ARF for the first few flights, gradually getting acquainted with it as you gain confidence. Adjust the trims to maintain straight and level flight. After flying around for a while, and while still at a safe altitude with plenty of fuel, practice slow flight and execute practice landing approaches by reducing the throttle to see

how the model handles at slower speeds. Add power to see how it climbs as well. Continue to fly around, executing various maneuvers and making mental notes (or having your assistant write them down) of what trim or C.G. changes may be required to fine tune the model so it flies the way you like. Mind your fuel level, but use this first flight to become familiar with your model before landing.

Landing

To initiate a landing approach, lower the throttle while on the downwind leg. Allow the nose of the model to pitch downward to gradually bleed off altitude. Continue to lose altitude, but maintain airspeed by keeping the nose down as you turn onto the crosswind leg. Make your final turn toward the runway (into the wind) keeping the nose down to maintain airspeed and control. Level the attitude when the model reaches the runway threshold, modulating the throttle as necessary to maintain your glide path and airspeed. If you are going to overshoot, smoothly advance the throttle (always ready on the right rudder to counteract torque) and climb out to make another attempt. When you're ready to make your landing flare and the model is a foot or so off the deck, smoothly increase up elevator until it gently touches down. Once the model is on the runway and has lost flying speed, hold up elevator to place the tail on the ground, regaining tail wheel control.

One final note about flying your model, have a goal or flight plan in mind for **every** flight. This can be learning a new maneuver(s), improving a maneuver(s) you already know, or learning how the model behaves in certain conditions (such as on high or low rates). This is not necessarily to improve your skills (*though it is never a bad idea!*), but more importantly so you do not surprise yourself by impulsively attempting a maneuver and suddenly finding that you've run out of time, altitude or airspeed. Every maneuver should be deliberate, not impulsive. For example, if you're going to do a loop, check your altitude, mind the wind direction (anticipating rudder corrections that will be required to maintain heading), remember to throttle back at the top, and make certain you are on the desired rates (high/low rates). A flight plan greatly reduces the chances of crashing your model just because of poor planning and impulsive moves.

Remember to think.

Have a ball!

But always stay in control and fly in a safe manner.

GOOD LUCK AND GREAT FLYING!

BUILDING NOTES

Kit Purchased Date: _____

Where Purchased: _____

Date Construction Started: _____

Date Construction Finished: _____

Finished Weight: _____

Date of First Flight: _____

FLIGHT LOG

ENGINE MOUNT TEMPLATE FOR FUJI-IMVAC BT-43EIS

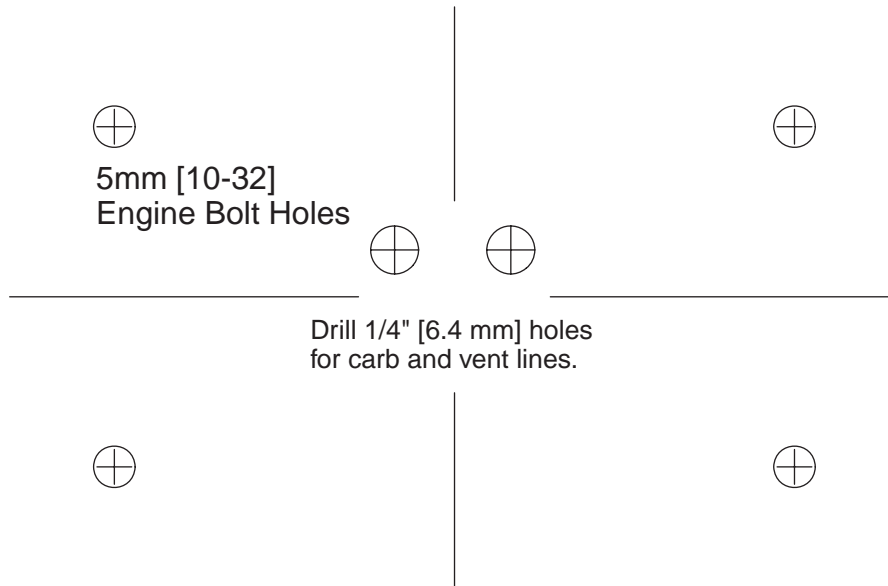

Glow Engine Mounting Template

(Dashed outline depicts
spacing for O.S. Max 1.60 FX)

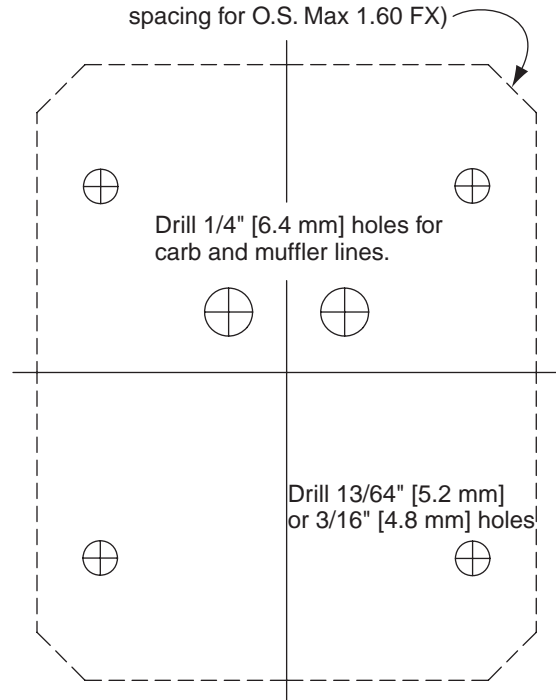

This model belongs to:

Name

Address

City, State Zip

Phone number

AMA number

OTHER ITEMS AVAILABLE

Great Planes® Ultimate Biplane 1.60 ARF GPMA1307



The Ultimate Bipe 1.60 ARF's polished look comes from precision-fitting parts made of select woods, surrounded by shimmering MonoKote® covering and topped off with a painted fiberglass cowl and wheel

pants. You'll have it assembled and ready for flight in about 20 hours! The lightweight construction - achieved in part through strategic use of lightening holes - provides an excellent power-to-weight ratio for outstanding 3D performance. Individual servos for each of the four ailerons supply maximum maneuvering muscle. There's also a custom-designed spinner, unique giant-scale hardware and airfoil-shaped landing gear that resists spreading under the model's weight. Special fittings in the stabilizers help easily achieve proper tension on the flying wires, and the wing panels secure in place with built-in thumbscrews!

Wingspan: 65 in (1650 mm)
Wing Area: 1446 sq in (93 dm²)
Weight: 12.5 lb (5670 g)
Wing Loading: 20 oz/sq in (61 g/dm²)
Length: 72 in (1830mm)
Requires: 1.60 cu in (26 cc) glow or 43cc gasoline engine
4-7 channel radio w/8-9 servos,
fuel and support equipment

Great Planes® 1/3 Scale Matt Chapman CAP 580 ARF GPMA1285

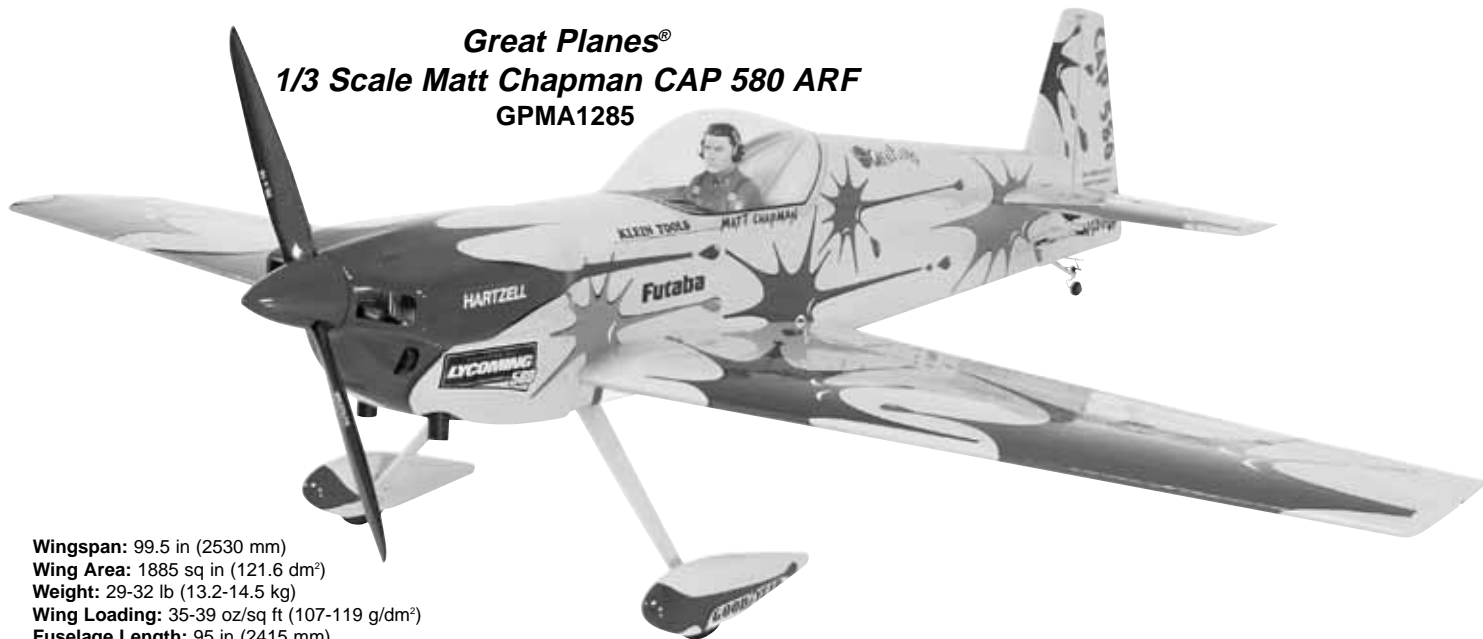

Wingspan: 99.5 in (2530 mm)
Wing Area: 1885 sq in (121.6 dm²)
Weight: 29-32 lb (13.2-14.5 kg)
Wing Loading: 35-39 oz/sq ft (107-119 g/dm²)
Fuselage Length: 95 in (2415 mm)
Requires: 4+ channel radio w/1-2 standard servos and 8 high-torque servos (6 standard, 2 giant-scale),
4.2-7.2 cu in (80-120 cc) glow or gasoline engine
support equipment

At more than 28 pounds and almost 100" in wingspan, this IMAA/IMAC-legal version of Matt Chapman's aerobate will dominate attention at the field. What's more, it can be ready for its first flight in as little as 15 hours. It arrives with the all-wood airframe already assembled and expertly covered in Top Flite® MonoKote®, complete with a generous hardware package. A painted fiberglass cowl and wheel pants are included, too, for no-finish/no-shaping ease. And its ability to perform 3D stunts is nothing short of amazing. There are two positions for the aluminum wing joiner tube, so CG can be fine-tuned by a change in wing location. Dual rudder servos and two servos per aileron provide the swift, strong response that precision flying requires.