

RV-4^{ARF}

INSTRUCTION MANUAL



Wingspan: 70 in [1780mm]
Wing Area: 1036 sq in [67dm²]
Weight: 9.5 – 10.5 lb [4310 – 4760g]
Wing Loading: 21 – 23 oz/sq ft [64 – 70g/dm²]
Length: 63 in [1600mm]
Radio: 5-channel with six 54 oz-in servos and one 30 oz-in servo
Glow Engine: .61 – .75 cu in [10 – 12cc] two-stroke, .91 cu in [15cc] four-stroke
Electric Motor: 50-65-450 RimFire™ motor

WARRANTY

Great Planes® Model Manufacturing Co. guarantees this kit to be free from defects in both material and workmanship at the date of purchase. This warranty does not cover any component parts damaged by use or modification. **In no case shall Great Planes' liability exceed the original cost of the purchased kit.** Further, Great Planes reserves the right to change or modify this warranty without notice.

In that Great Planes has no control over the final assembly or material used for final assembly, no liability shall be assumed nor accepted for any damage resulting from the use by the user of the final user-assembled product. By the act of using the user-assembled product, the user accepts all resulting liability.

If the buyer is not prepared to accept the liability associated with the use of this product, the buyer is advised to return this kit immediately in new and unused condition to the place of purchase.

To make a warranty claim send the defective part or item to Hobby Services at the address below:

Hobby Services
3002 N. Apollo Dr., Suite 1
Champaign, IL 61822 USA

Include a letter stating your name, return shipping address, as much contact information as possible (daytime telephone number, fax number, e-mail address), a detailed description of the problem and a photocopy of the purchase receipt. Upon receipt of the package the problem will be evaluated as quickly as possible.

READ THROUGH THIS MANUAL BEFORE STARTING CONSTRUCTION. IT CONTAINS IMPORTANT WARNINGS AND INSTRUCTIONS CONCERNING THE ASSEMBLY AND USE OF THIS MODEL.



Champaign, Illinois
(217) 398-8970, Ext 5
airsupport@greatplanes.com

TABLE OF CONTENTS

INTRODUCTION.....	2
AMA.....	2
IMAA.....	2
SAFETY PRECAUTIONS.....	3
DECISIONS YOU MUST MAKE.....	3
Radio Equipment.....	3
Engine Recommendations.....	3
Electric Motor & Motor Mount Recommendations.....	4
ADDITIONAL ITEMS REQUIRED.....	4
Adhesives & Building Supplies.....	4
Optional Supplies & Tools.....	4
IMPORTANT BUILDING NOTES.....	4
ORDERING REPLACEMENT PARTS.....	5
KIT INSPECTION.....	6
KIT CONTENTS.....	6
METRIC / INCH RULER.....	6
PREPARATIONS.....	7
ASSEMBLY INSTRUCTIONS.....	7
ASSEMBLE THE WING.....	7
Install the Ailerons & Flaps.....	7
Install the Aileron, Flap Servos & Pushrods.....	8
ASSEMBLE THE FUSELAGE.....	10
Install the Stab, Elevators & Rudder.....	10
Install the Landing Gear & Wheel Pants.....	11
Electric Motor / Glow Engine Installation.....	13
Electric Motor, ESC & Battery Installation.....	13
Install the Glow Engine, Fuel Tank & Throttle Servo.....	14
Install the Radio, Servos & Pushrods.....	17
Assemble the Canopy.....	20
Install the Cowl.....	21
Apply the Decals.....	23
GET THE MODEL READY TO FLY.....	23
Check the Control Directions.....	23
Set the Control Throws.....	23
Balance the Model (C.G.).....	24
Balance the Model Laterally.....	24
PREFLIGHT.....	25
Identify Your Model.....	25
Charge the Batteries.....	25
Balance the Propellers.....	25
Ground Check.....	25
Range Check.....	25
ENGINE SAFETY PRECAUTIONS.....	25
MOTOR & BATTERY SAFETY PRECAUTIONS.....	26
AMA SAFETY CODE (excerpts).....	26
IMAA SAFETY CODE (excerpts).....	27
CHECK LIST.....	28
FLYING.....	29
Fuel Mixture Adjustments.....	29
Takeoff.....	29
Flight.....	29
Landing.....	29

INTRODUCTION

For the latest technical updates or manual corrections to the RV-4 ARF visit the Great Planes web site at www.greatplanes.com. Open the "Airplanes" link, then select the RV-4 ARF. If there is new technical information or changes to this model a "tech notice" box will appear in the upper left corner of the page.

AMA

We urge you to join the **AMA** (Academy of Model Aeronautics) and a local R/C club. The AMA is the governing body of model aviation and membership is required to fly at AMA clubs. Though joining the AMA provides many benefits, one of the primary reasons to join is liability protection. Coverage is not limited to flying at contests or on the club field. It even applies to flying at public demonstrations and air shows. Failure to comply with the Safety Code (excerpts printed in the back of the manual) may endanger insurance coverage. Additionally, training programs and instructors are available at AMA club sites to help you get started the right way. There are over 2,500 AMA chartered clubs across the country. Contact the AMA at the address or toll-free phone number below.



Academy of Model Aeronautics
5151 East Memorial Drive
Muncie, IN 47302
Tele: (800) 435-9262
Fax (765) 741-0057
Or via the Internet at:
<http://www.modelaircraft.org>

IMPORTANT!!! Two of the most important things you can do to preserve the radio controlled aircraft hobby are to avoid flying near full-scale aircraft and avoid flying near or over groups of people.

IMAA

The Great Planes RV-4 ARF is an excellent sport-scale model and is eligible to fly in IMAA events. The **IMAA** (International Miniature Aircraft Association) is an organization that promotes non-competitive flying of giant-scale models. If you plan to attend an IMAA event, obtain a copy of the **IMAA Safety Code** by contacting the IMAA at the address or telephone number below, or by logging on to their web site at:

IMAA
205 S. Hilldale Road
Salina, KS 67401
(913) 823-5569
www.fly-ima.org/ima/sanction.html

Scale Competition

Though the Great Planes RV-4 is an ARF and may not have the same level of detail as an "all-out" scratch-built competition model, it is a scale model nonetheless and is therefore eligible to compete in the Fun Scale class in AMA competition (we receive many favorable reports of Great Planes ARFs in scale competition!). In Fun Scale, the "builder of the model" rule does not apply. To receive the five points for scale documentation,

the only proof required that a full size aircraft of this type in this paint/markings scheme did exist is a single sheet such as a kit box cover from a plastic model, a photo, or a profile painting, etc. If the photo is in black and white other written documentation of color must be provided. Contact the AMA for a rule book with full details.

If you would like photos of full-size RV-4's for scale documentation, or if you would like to study the photos to add more scale details, photo packs are available from:

Bob's Aircraft Documentation
3114 Yukon Ave.
Costa Mesa, CA 92626

Telephone: (714) 979-8058

Fax: (714) 979-7279

E-mail: www.bobsairdoc.com

PROTECT YOUR MODEL, YOURSELF & OTHERS...FOLLOW THESE IMPORTANT SAFETY PRECAUTIONS

1. Your RV-4 ARF should not be considered a toy, but rather a sophisticated, working model that functions very much like a full-size airplane. Because of its performance capabilities, the RV-4 ARF, if not assembled and operated correctly, could possibly cause injury to yourself or spectators and damage to property.

2. You must assemble the model **according to the instructions**. Do not alter or modify the model, as doing so may result in an unsafe or unflyable model. In a few cases the instructions may differ slightly from the photos. In those instances the written instructions should be considered as correct.

3. You must take time to **build straight, true and strong**.

4. You must use an R/C radio system that is in first-class condition, and a correctly sized engine and components (fuel tank, wheels, etc.) throughout the building process.

5. You must correctly install all R/C and other components so that the model operates correctly on the ground and in the air.

6. You must check the operation of the model before **every** flight to insure that all equipment is operating and that the model has remained structurally sound. Be sure to check clevises or other connectors often and replace them if they show any signs of wear or fatigue.

7. If you are not an experienced pilot or have not flown this type of model before, we recommend that you get the assistance of an experienced pilot in your R/C club for your first flights. If you're not a member of a club, your local hobby shop has information about clubs in your area whose membership includes experienced pilots.

8. While this kit has been flight tested to exceed normal use, if the plane will be used for extremely high-stress flying, such as racing, or if an engine larger than one in the recommended range is used, the modeler is responsible for taking steps to reinforce the high-stress points and/or substituting hardware more suitable for the increased stress.

9. **WARNING:** The cowl and wheel pants included in this kit are made of fiberglass, the fibers of which may cause eye, skin and respiratory tract irritation. Never blow into a part (wheel pant, cowl) to remove fiberglass dust, as the dust will blow back into your eyes. Always wear safety goggles, a particle mask and rubber gloves when grinding, drilling and sanding fiberglass parts. Vacuum the parts and the work area thoroughly after working with fiberglass parts.

We, as the kit manufacturer, provide you with a top quality, thoroughly tested kit and instructions, but ultimately the quality and flyability of your finished model depends on how you build it; therefore, we cannot in any way guarantee the performance of your completed model, and no representations are expressed or implied as to the performance or safety of your completed model.

Remember: Take your time and follow the instructions to end up with a well-built model that is straight and true.

DECISIONS YOU MUST MAKE

This is a partial list of items required to finish the RV-4 ARF that may require planning or decision making before starting to build. Order numbers are provided in parentheses.

Radio Equipment

- 5-Channel radio (minimum)
- (6) 54 oz-in Servos and one 30 oz-in servo.
- 12" [300mm] Servo extension (HCAM2711 for Futaba®)
- (2) Y-harnesses (HCAM2751 for Futaba)
- 4.8V, 500mAh Battery or greater

Engine Recommendations

The recommended engine size range for the RV-4 ARF is .61 to .75 two-stroke or .91 four-stroke. If an engine in the upper end of the size range is used, remember that this is a scale model that is intended to fly at scale-like speeds, so throttle management should be practiced.

Electric Motor & Motor Mount Recommendations

We have flown the RV-4 ARF extensively on a variety of motors to find the best performance for this airplane. The following items proved to power the plane very well, giving similar performance to the .91 glow engine.

Motor

- C50-65-450 RimFire™ brushless out-runner motor (GPMG4770)
- SS 80 Silver Series 80A ESC (GPMM1860)
- (4) 3 x 8mm Machine screws
- (4) 3mm Washers

Motor Mount

- Brushless Motor Mount (large, GPMG1260)

Prop

- APC 16x8E or 16x6 standard prop for a glow engine

Battery

We tested this plane with LiPo and NiMH batteries. The LiPo batteries provided slightly longer flight times and weighed less than the NiMH batteries.

- 6S1P 3200mAh LiPo battery (2) ElectriFly™ 3200mAh 11.1V batteries, GPMP0623)
- One Series Adapter, (2) Deans males (GPMM3143)

or

- 12 volt (10-cell) 3600 NiMH battery with flat Deans Connectors (GPMP0363)

We recommend the Great Planes ElectriFly PolyCharge 4™ LiPo charger (GPMM3015) for LiPo batteries and the Triton™ Peak Charger (GPMM3150) for NiMH batteries.

ADDITIONAL ITEMS REQUIRED

Adhesives & Building Supplies

- 1/2 oz. [15g] Thin Pro™ CA (GPMR6001)
- 1 oz. [30g] Medium Pro CA+ (GPMR6008)
- Pro 6-minute epoxy (GPMR6045)
- Drill bits: 1/32" [.8mm], 1/16" [1.6mm], 5/64" [2mm], 3/32" [2.4mm], 9/64" [3.6mm], 3/16" [4.8mm].
- 8-32 Tap and drill set (GPMR8103)
- R/C-56 canopy glue (JOZR5007)
- CA applicator tips (HCAR3780)
- Mixing sticks (50, GPMR8055)
- Mixing cups (GPMR8056)
- Masking tape (TOPR8018)

- Threadlocker™ thread-locking compound (GPMR6060)
- R/C foam rubber (1/4" [6mm] – HCAQ1000, or 1/2" [13mm] – HCAQ1050)
- 3' [900mm] Standard silicone fuel tubing (GPMQ4131, for glow engine installation only!)

Optional Supplies & Tools

- Fuel Filler Valve (for glow fuel GPMQ4160)
- Stick-on segmented lead weights (GPMQ4485)
- Silver Solder w/flux (GPMR8070)
- #1 Hobby knife (HCAR0105)
- #11 Blades (5-pack, HCAR0211)
- Small T-pins (100, HCAR5100)
- 21st Century® sealing iron (COVR2700)
- 21st Century iron cover (COVR2702)
- 21st Century trim seal iron (COVR2750)
- 2 oz. [57g] Spray CA activator (GPMR6035)
- CA debonder (GPMR6039)
- Curved-tip canopy scissors (for trimming plastic parts HCAR0667)
- Robart Super Stand II (ROBP1402)
- CG Machine™ (GPMR2400)
- Rotary tool such as Dremel®
- Rotary tool reinforced cut-off wheel (GPMR8020)
- Servo horn drill (HCAR0698)
- Hobby Heat™ micro torch (HCAR0750)
- Dead Center™ engine mount hole locator (GPMR8130)
- AccuThrow™ deflection gauge (GPMR2405)
- Denatured alcohol (for epoxy clean up)

IMPORTANT BUILDING NOTES

- **Sheet Metal Screws (SMS)** are designated by a number and a length. For example #6 x 3/4" [19mm].

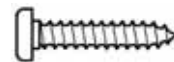

This is a number six screw that is 3/4" [19mm] long.

- **Machine Screws (MS)** are designated by a number, **threads per inch**, and a length. For example 4-40 x 3/4" [19mm].



This is a number four screw that is 3/4" [19mm] long with forty threads per inch.

- **Socket Head Cap Screws (SHCS)** are designated by a number, **threads per inch**, and a length. For example 4-40 x 1-1/2" [38mm].



This is a number four screw that is 1-1/2" [38mm] long with forty threads per inch.

- When you see the term **test fit** in the instructions, it means that you should first position the part on the assembly **without using any glue**, then slightly modify or *custom fit* the part as necessary for the best fit.
- Whenever the term **glue** is written you should rely upon your experience to decide what type of glue to use. When a specific type of adhesive works best for that step, the instructions will make a recommendation.
- Whenever just **epoxy** is specified you may use **either** 30-minute (or 45-minute) epoxy **or** 6-minute epoxy. When 30-minute epoxy is specified it is **highly** recommended that you use only 30-minute (or 45-minute) epoxy, because you will need the working time and/or the additional strength.
- **Photos** and **sketches** are placed **before** the step they refer to. Frequently you can study photos in following steps to get another view of the same parts.
- The RV-4 ARF is factory-covered with Top Flite® MonoKote® film. Should repairs ever be required, MonoKote can be patched with additional MonoKote purchased separately. MonoKote is packaged in six-foot rolls, but some hobby shops also sell it by the foot. If only a small piece of MonoKote is needed for a minor patch, perhaps a fellow modeler would give you some. MonoKote is applied with a model airplane covering iron, but in an emergency a regular iron could be used. A roll of MonoKote includes full instructions for application. Following are the colors used on this model and order numbers for six foot rolls.

White – TOPQ0204
 Aluminum – TOPQ0205
 Black – TOPQ0208
 Metallic Red – TOPQ0405

- The stabilizer and wing incidences and engine thrust angles have been factory-built into this model. However, some technically-minded modelers may wish to check these measurements anyway. To view this information visit the web site at **www.greatplanes.com** and click on "Technical Data." Due to manufacturing tolerances which will have little or no effect on the way your model will fly, please expect slight deviations between your model and the published values.

ORDERING REPLACEMENT PARTS

Replacement parts for the Great Planes RV-4 ARF are available using the order numbers in the **Replacement Parts List** that follows. The fastest, most economical service can be provided by your hobby dealer or mail-order company.

To locate a hobby dealer, visit the Hobbico web site at **www.hobbico.com**. Choose "Where to Buy" at the bottom of the menu on the left side of the page. Follow the instructions provided on the page to locate a U.S., Canadian or International dealer.

Parts may also be ordered directly from Hobby Services by calling (217) 398-0007, or via facsimile at (217) 398-7721, but full retail prices and shipping and handling charges will apply. Illinois and Nevada residents will also be charged sales tax. If ordering via fax, include a Visa® or MasterCard® number and expiration date for payment.

Mail parts orders and payments by personal check to:

Hobby Services
 3002 N. Apollo Drive, Suite 1
 Champaign, IL 61822

Be certain to specify the order number exactly as listed in the **Replacement Parts List**. Payment by credit card or personal check only; no C.O.D.

If additional assistance is required for any reason contact Product Support by e-mail at **productsupport@greatplanes.com**, or by telephone at (217) 398-8970.

Description	How to Purchase
Missing pieces	Contact Product Support
Instruction manual	Contact Product Support
Full-size plans	Not available
Kit parts listed below	Hobby Supplier

Replacement Parts List

- GPMA3030.....Wing Set
- GPMA3031.....Wing Tube
- GPMA3032.....Fuse w/Hatch
- GPMA3033.....Wheel Pants
- GPMA3034.....Cowl
- GPMA3035.....Landing Gear Set
- GPMA3036.....Spinner w/Hardware
- GPMA3037.....Canopy
- GPMA3038.....Tail Set
- GPMA3039.....Decal Sheet

KIT INSPECTION

Before starting to build, take an inventory of this kit to make sure it is complete, and inspect the parts to make sure they are of acceptable quality. If any parts are missing or are not of acceptable quality, or if you need assistance with assembly, contact **Product Support**. When reporting defective or missing parts, use the part names exactly as they are written in the Kit Contents list on this page.

Great Planes Product Support
3002 N. Apollo Drive, Suite 1
Champaign, IL 61822
Telephone: (217) 398-8970, ext. 5
Fax: (217) 398-7721
E-mail: airsupport@greatplanes.com

KIT CONTENTS

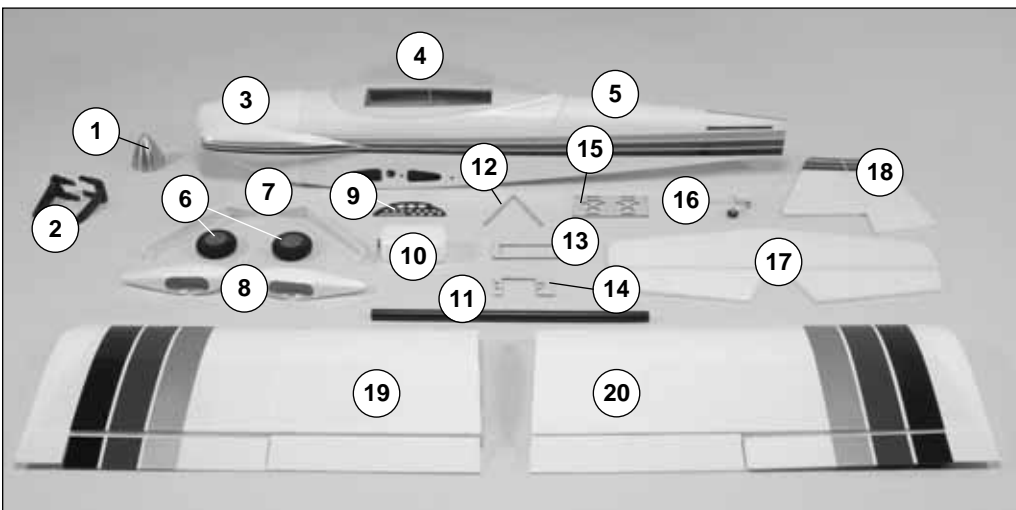

Kit Contents

1. Spinner
2. Engine Mount (L&R)
3. Cowl
4. Canopy
5. Fuselage
6. Wheels (2)
7. Landing Gear
8. Wheels Pants (L&R)
9. Instrument Panel
10. Fuel Tank
11. Aluminum Wing Joiner Tube
12. Turn-Over Post
13. Secondary Servo Tray
14. Fuel Tank Former
15. Secondary Receiver/Battery Tray
16. Tail Wheel Assembly
17. Horizontal Stab & Elevators
18. Vertical Fin & Rudder
19. Left Wing Panel w/Aileron & Flap
20. Right Wing Panel w/Aileron & Flap

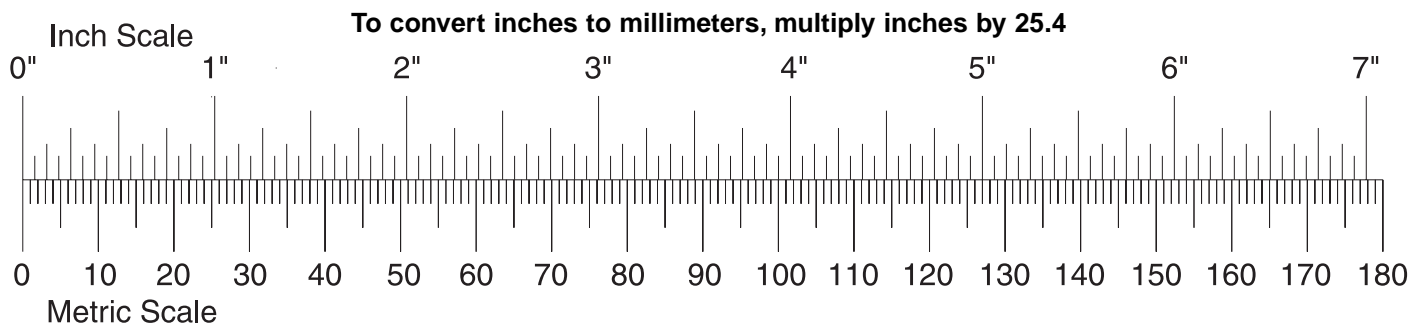

PREPARATIONS

- ❑ 1. If you have not done so already, remove the major parts of the kit from the box and inspect for damage. If any parts are damaged or missing, contact Product Support at the address or telephone number listed in the “*Kit Inspection*” section on page 6.



- ❑ 2. Remove the tape and separate the ailerons and flaps from the wing and the elevators from the stab. Use a covering iron with a covering sock on high heat to tighten the covering if necessary. Apply pressure over sheeted areas to **thoroughly** bond the covering to the wood.

ASSEMBLY INSTRUCTIONS

ASSEMBLE THE WING

Install the Ailerons & Flaps

Do the right wing panel first so your work matches the photos the first time through.

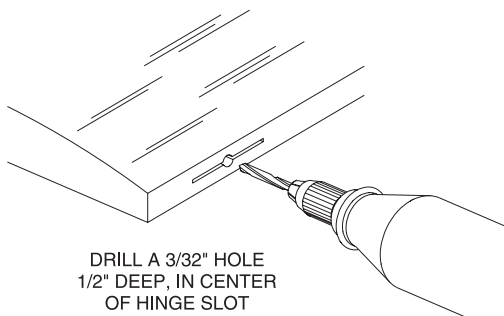

- ❑ 1. Drill a 3/32" hole, 1/2" [13mm] deep in the center of each hinge slot to allow the CA to “wick” in. Follow-up with a #11 blade to clean out the slots. **Hint:** If you have one, use a high-speed rotary tool to drill the holes.

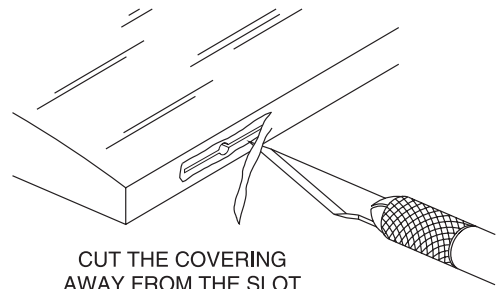

- ❑ 2. Use a sharp #11 blade to cut a strip of covering from the hinge slots in the wing and aileron.

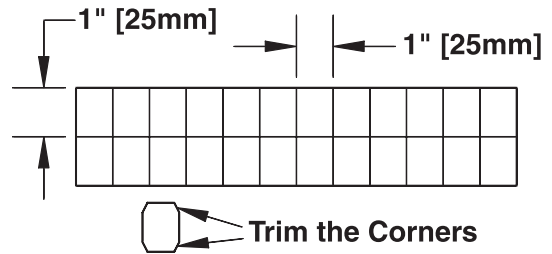

- ❑ 3. Cut twelve (12) 1" x 1" [25 x 25mm] hinges from the CA hinge strip. Snip off the corners so they go in easier.

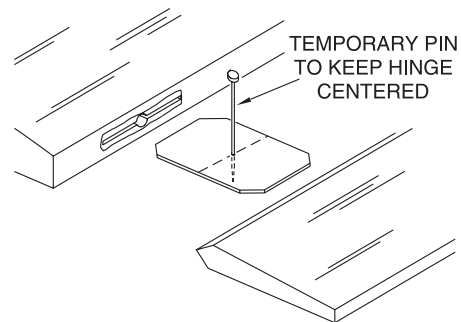

- ❑ 4. Test fit the right aileron to the wing with four hinges. If the hinges don't remain centered, stick a pin through the middle of the hinge to hold it in position.

- ❑ 5. Remove any pins you may have inserted into the hinges. Adjust the aileron so there is a small gap between the LE of the aileron and the wing. The gap should be small, just enough to see light through or to slip a piece of paper through.



- ❑ 6. Apply six drops of thin CA to the top and bottom of each hinge. Do not use CA accelerator. After the CA has fully hardened, test the hinges by pulling on the aileron.

□ □ 7. Test fit the right flap to the wing with three hinges. Using the same procedure used for the ailerons, join the flaps to the wing.

□ □ 8. Repeat steps 1 to 7 for the left wing panel.

Install the Aileron, Flap Servos & Pushrods

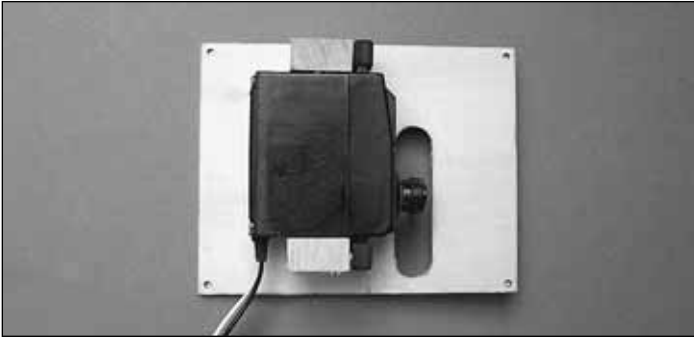

□ □ 1. Remove the aileron servo cover from the wing. Position the aileron servo and center the output shaft over the opening in the servo cover. Glue a 5/8" x 3/4" x 5/16" [16 x 19 x 8mm] hardwood block to the cover on each side of the servo.



□ □ 2. Install the aileron servo into the aileron servo opening. Drill through the servo mounting holes with a 1/16" [1.6mm] drill bit. Remove the servo from the servo opening. Install and then remove a servo mounting screw into each of the holes you have drilled. Apply a drop of thin CA into the holes to harden the threads. Once the glue has hardened install the servo into the servo opening using the hardware included with your servo. Center the servo, and then install a servo arm as shown.

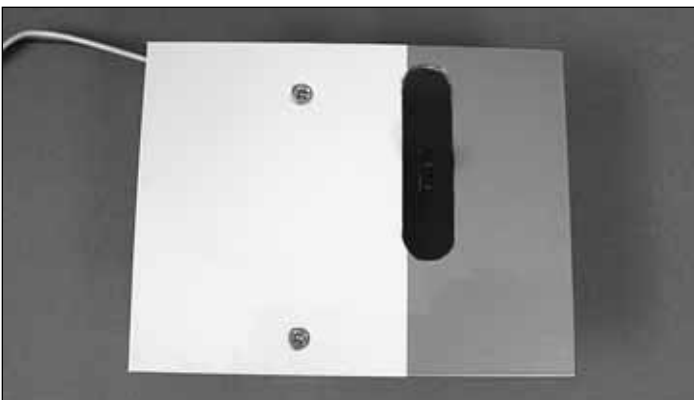

□ □ 3. Make a mark on the servo cover centered over the servo mounting block. Drill through the cover into the servo

mounting block with a 1/16" [1.6mm] drill bit. Install a #2 x 3/8" [9.5mm] wood screw into the hole to secure the servo block to the cover.

□ □ 4. Install a 12" [305mm] servo extension onto the aileron servo lead. Secure the extension to the lead with tape, a piece of heat-shrink tubing or some other method to keep them from coming unplugged.

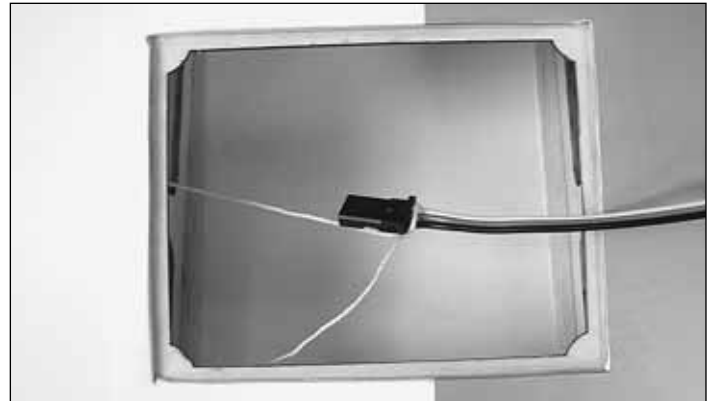

□ □ 5. Taped inside the aileron servo opening is a string. Tie the aileron servo extension to the string in the aileron servo opening. Pull the servo lead through the wing with the string that is taped to the root rib. Untie the string from the leads and tape the lead to the wing root to prevent it from falling back into the wing.

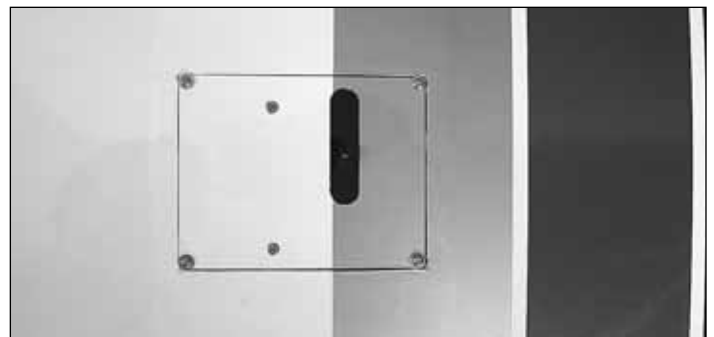

□ □ 6. Drill through the holes in the corners of the aileron servo cover with a 1/16" [1.6mm] drill bit. Install #2 x 3/8" [9.5mm] SMS and #2 washers in each corner of the cover.

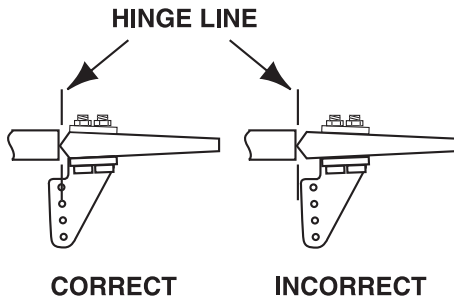

7. Place a nylon control horn in line with the last hole in the aileron servo arm. When positioned properly the control horn will rest on a hardwood plate in the aileron. Mark the location of the mounting holes onto the aileron. Drill a 1/16" [1.6mm] hole on the marks, drilling through the plywood plate but not through the top of the aileron. Insert and remove a #2 x 3/8" [9.5mm] screw into each of the holes. Apply a couple drops of thin CA into the holes to harden the threads. Once the glue has hardened attach the control horn to the aileron with two #2 x 3/8" [9.5mm] screws.

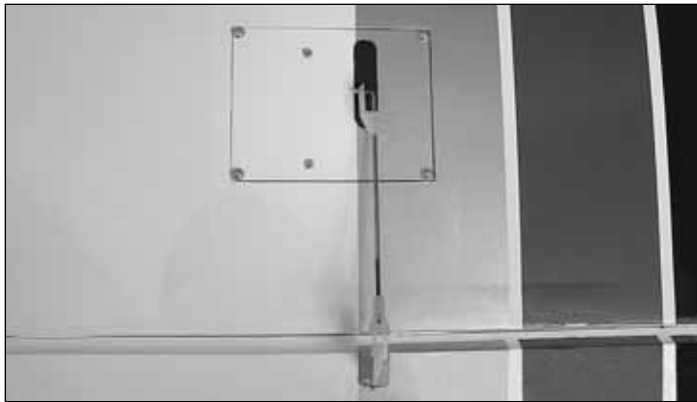

8. Locate a .074" x 6" [.074" x 152mm] pushrod wire threaded on one end. Screw a nylon clevis onto the threaded end of the wire 20 full turns. Install a silicone clevis keeper onto the clevis. Then, install the clevis in the second hole from the end of the aileron control horn.

9. Be sure the aileron servo is centered. Enlarge the outer hole in the servo arm with a Hobbico® Servo Horn Drill (or a #48 or 5/64" [2mm] drill bit). Center the aileron and align the wire pushrod with the hole in the end of the servo arm. Using a marker, mark the location where the wire aligns with the hole in the servo arm. On that mark make a 90° bend. From the bend, measure an additional 3/16" [4.8mm]. Then, cut off the excess pushrod wire.

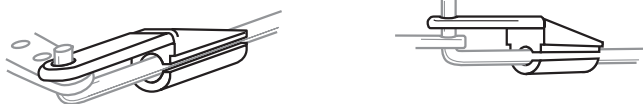

10. Install the wire into the hole in the servo arm using a nylon FasLink as shown in the sketch.

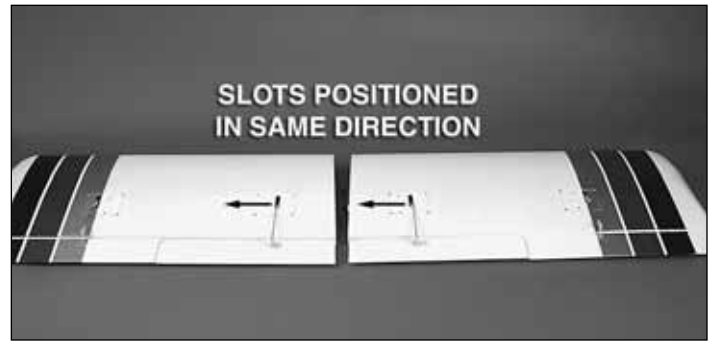

11. Install the flap servo into the flap servo opening, mounting it using the same procedure for the aileron servo (no servo extension is required for the flap servo). Install the servo arm onto the flap servo with the arm pointing towards the wing tip. **Important!!** When instructed to do the left wing, the arm on the flap servo must point towards the root rib, not the wing tip as was done on the right wing panel.

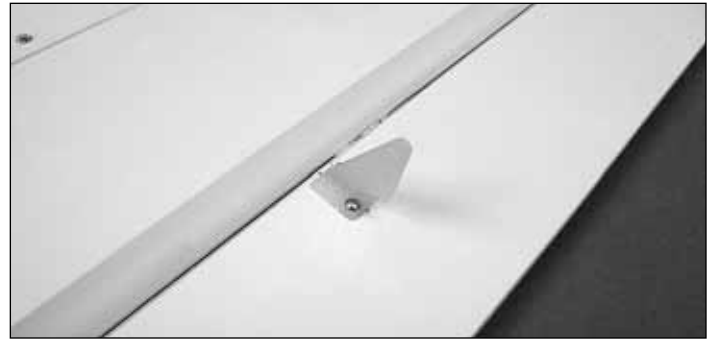

12. Place a nylon control horn in line with the last hole in the flap servo arm. The nylon control horn should be positioned 180 degrees opposite from the way the aileron control horn was installed. When positioned properly the control horn will rest on a hardwood plate in the flap. Mark the location of the mounting holes onto the aileron. Drill a 1/16" [1.6mm] hole on the marks, drilling through the plywood plate but not through the top of the flap. Insert and remove a #2 x 3/8" [9.5mm] screw into each of the holes. Apply a couple drops of thin CA into the holes to harden the threads. Once the glue has hardened attach the control horn to the flap with two #2 x 3/8" [9.5mm] screws.

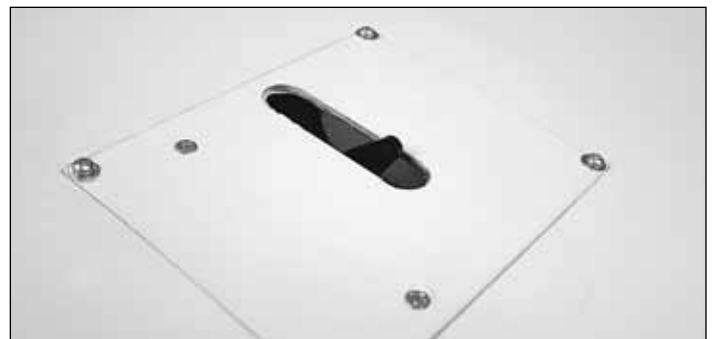

13. Enlarge the outer hole in the flap servo arm with a Hobbico Servo Horn Drill (or a #48 or 5/64" [2mm] drill bit). Position the flap servo arm as shown.

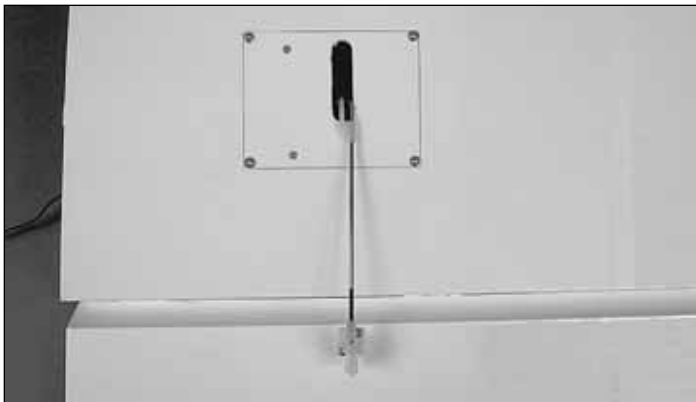

14. Locate a .074" x 6" [.074" x 152mm] pushrod wire threaded on one end. Screw a nylon clevis onto the threaded end of the wire 20 full turns. Install a silicone clevis keeper onto the clevis. Then, install the clevis in the second hole from the end of the flap control horn. Center the flap and align the wire pushrod with the hole in the end of the servo arm. Using a marker, mark the location where the wire aligns with the hole in the servo arm. On that mark make a 90° bend. From the bend, measure an additional 3/16" [4.8mm]. Then, cut off the excess pushrod wire. Install the wire into the hole in the servo arm using a nylon FasLink.



15. Locate two 1/4" x 1" [6 x 25mm] wood dowels. Glue them into the holes as shown.

16. Repeat steps 1 to 15 for the left wing.

ASSEMBLE THE FUSELAGE

Install the Stab, Elevators & Rudder

1. Install the aluminum wing joiner tube into the hole in the fuselage. Slide the wing panels onto the tube, sliding the wing panels against the fuselage.

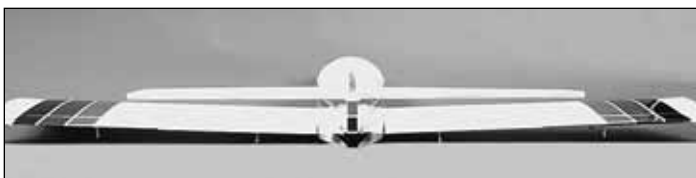

2. Test fit the stab into the opening in the back of the fuselage. Stand back and look at the stab in relation to the wing. The stab should be parallel with the wing. If not, sand the stab saddle until the stab and wing are aligned.

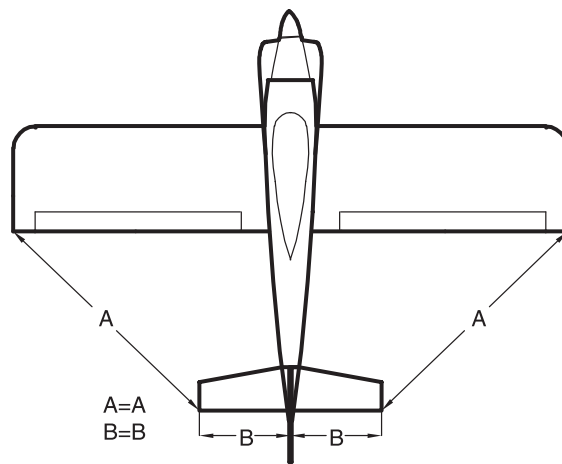

2. Measure the distance from the tip of the stab to the tip of each wing. Adjust the position of the stab until both are equal.



3. Using a fine-tip marker, trace the outline of the fuselage onto the top and bottom of the stab.

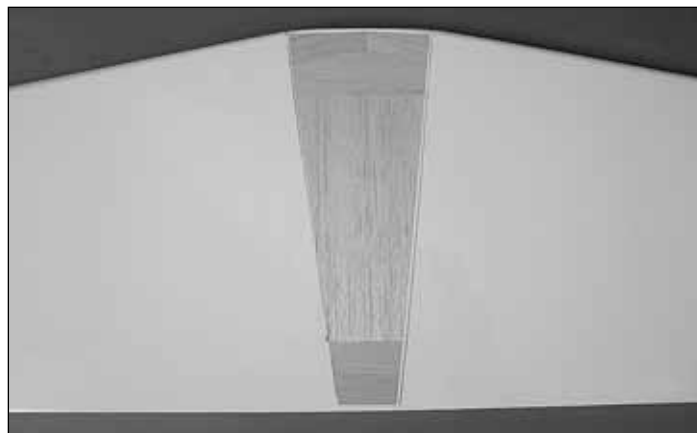

4. Remove the stab from the fuselage. Use a sharp #11 blade or the expert tip that follows to cut the covering inside the lines you have drawn. Use caution not to cut through the surface of the wing skin. Remove the covering.



HOW TO CUT COVERING FROM Balsa

Use a soldering iron to cut the covering from the fin. The tip of the soldering iron doesn't have to be sharp, but a fine-tip does work best. Allow the iron to heat fully.

Use a straightedge to guide the soldering iron at a rate that will just melt the covering and not burn into the wood. The hotter the soldering iron, the faster it must travel to melt a fine cut. Peel off the covering.

- ❑ 5. Re-install the stab back into the fuselage. Double-check the position of the stab. When you are satisfied with the position and fit, use thin CA with a CA applicator tip to wick glue into the stab saddle. Apply the glue to the top, bottom and both sides of the fuselage. Allow the glue to fully cure before moving. After the glue has cured remove the wing from the fuselage. **Hint:** Do not use any accelerator. This will most likely cause the glue to get a white haze on the fuselage and stab. Allow the plane to sit for approximately 5 minutes until the glue is completely cured.

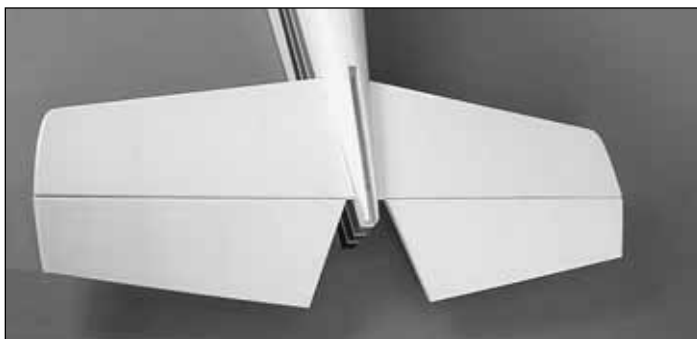

- ❑ 6. Cut six hinges from the hinge material. Install the two elevator halves using the same method used for the ailerons. Once you are satisfied with the positioning of the elevators, glue them in place with thin CA the same as was done on the ailerons.



- ❑ 7. Slide the vertical fin into the slot in the top of the fuselage. Trace the outline of the fuselage onto the fin with a fine-tip marker. Remove the fin from the slot and cut the covering away using the same technique used for the stab.

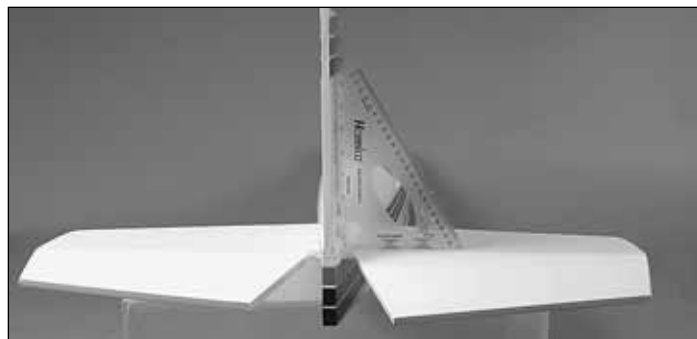

- ❑ 8. Glue the fin into the slot in the fuselage, making sure the fin is perpendicular to the stab.



- ❑ 9. Cut four more hinges and insert them into the rudder. Insert the rudder hinges to the fin and apply thin CA onto the hinges using the same technique you used on the elevators.

This completes the installation of the tail surfaces. You will finish the installation of the control horns and pushrods when you do the radio installation.

Install the Landing Gear & Wheel Pants

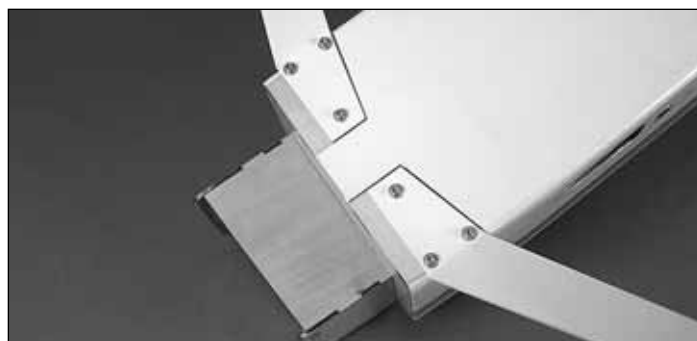

- ❑ ❑ 1. Bolt the landing gear to the fuselage with six 6-32 x 3/4" [19mm] SHCS, #6 lock washers and #6 flat washers. Apply a drop of threadlocker to the threads before screwing them into the fuselage.



❑ ❑ 2. Locate the 2" [51mm] axles. Cut both axles to a length of 1-3/4" [44mm]. A high-speed rotary tool with a cut-off wheel works well for this application. Install the axle and axle nut onto the landing gear.



❑ ❑ 3. File a flat spot on the end of the axle. A high-speed rotary tool works well for this also.



❑ ❑ 4. Insert a 6-32 set screw into a 5/32" [4mm] wheel collar. Slide it onto the axle. Slide the wheel onto the axle, and then slide another 5/32" [4mm] wheel collar. Screw another 6-32 set screw into the wheel collar with a drop of threadlocker. Center the wheel, and then tighten the set screws on the wheel collars.

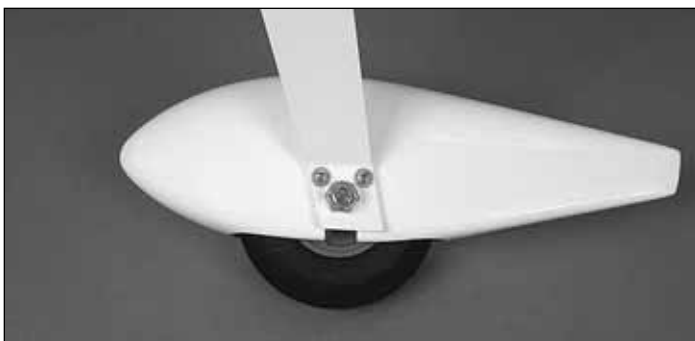

❑ ❑ 5. Slide the wheel pant over the wheel. Attach the wheel pant to the landing gear with two 4-40 x 1/2" [13mm] MS, #4 flat washers and #4 lock washers.

❑ 6. Repeat step 1 to 5 for the other wheel pant.

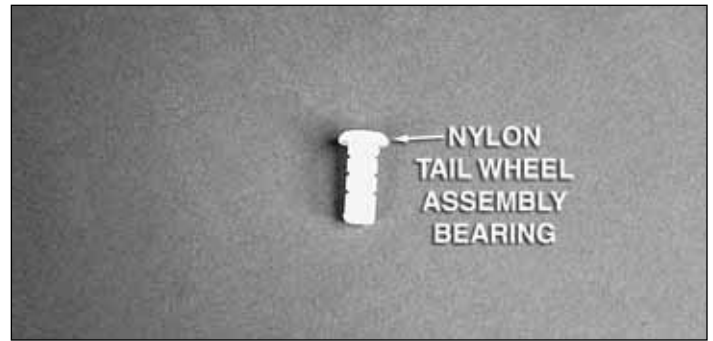

❑ 7. Locate the nylon tail wheel assembly bearing. Glue it into the hole located on the bottom, back of the fuselage.

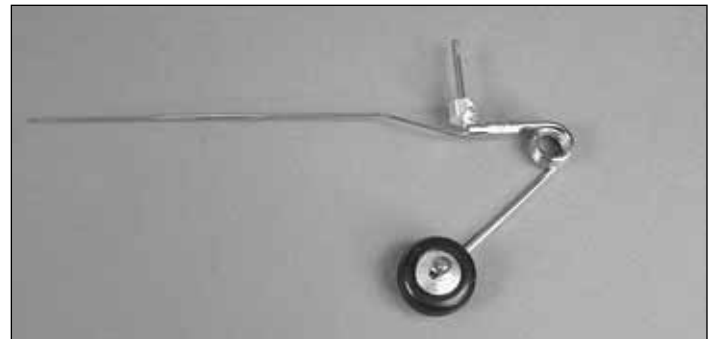

❑ 8. Install the two wheel collars onto the tail wheel assembly as shown. Install and tighten the set screw into the wheel collar.



❑ 9. Install the tail wheel assembly. Position the "L-bracket" onto the fuselage, making sure it is over the top of the wheel collar. Drill a 1/32" [.8mm] hole through each of the mounting holes in the bracket. Secure the bracket to the fuselage with the two SMS provided in the tail wheel assembly hardware.

Electric Motor, ESC & Battery Installation

Note: The recommended components for this installation can be found at the **“Electric Motor and Motor Mount Recommendations”** section of this instruction manual on page 4.

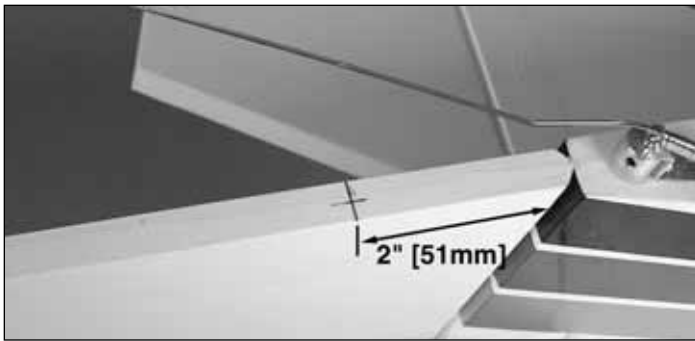

❑ 10. From the LE of the rudder measure back 2" [51mm] and make a mark. Drill a 5/32" [4mm] hole into the rudder on the mark.

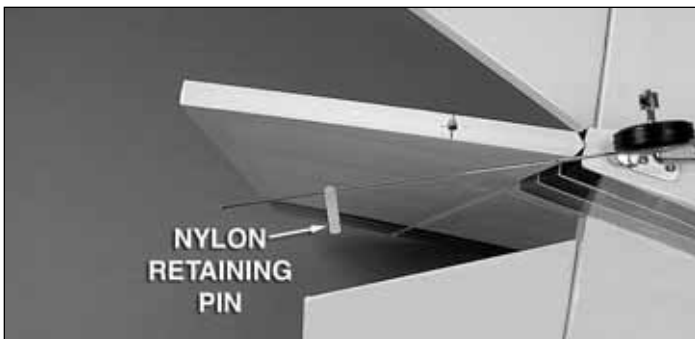

❑ 11. Locate the nylon retaining pin and slide it onto the wire on the end of the tail wheel assembly.

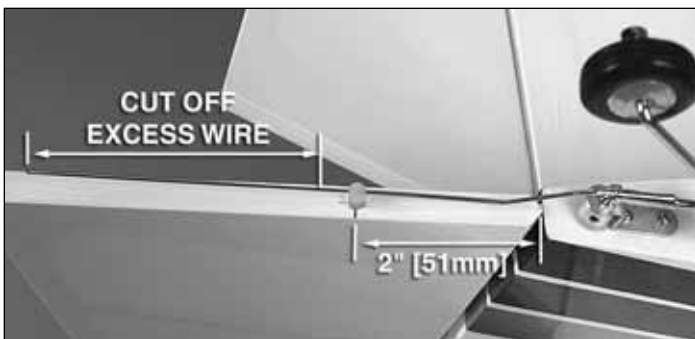

❑ 12. Glue the pin into the hole in the rudder. Cut off the excess wire from the tail wheel assembly.

Electric Motor / Glow Engine Installation

We are providing instructions for the installation of an electric motor and ESC as well as the installation of a glow engine. You should determine which you will be using before you continue. Though the engine or the motor will mount in a similar manner, the servos are installed differently for an electric motor than they are for a glow engine. If you will be installing a glow engine, skip ahead to **“Install the Glow Engine, Fuel Tank and Throttle Servo Installation”** on page 14.

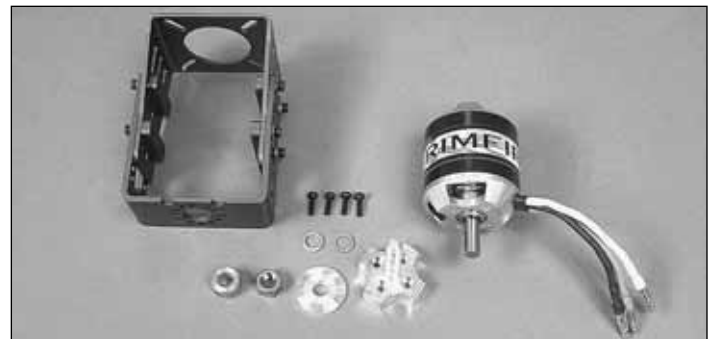

❑ 1. Locate the components of the electric power system including the motor, two spacers, wheel collar, prop adapter, mounting screws and the motor mount.



❑ 2. Remove the front half of the motor mount and install the motor to the mount and the prop adapter to the front of the motor with four 3 x 8mm MS (not included). Be sure to use a drop of threadlocker on each of the bolts.

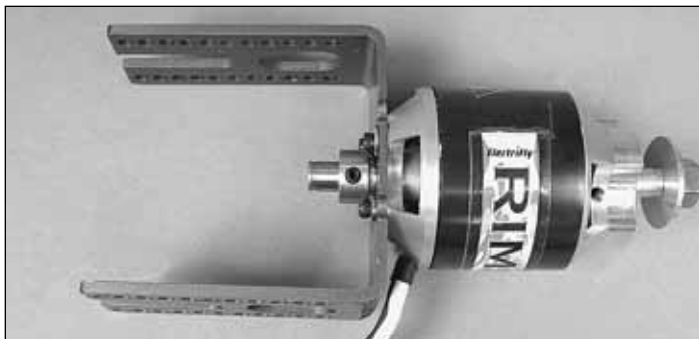
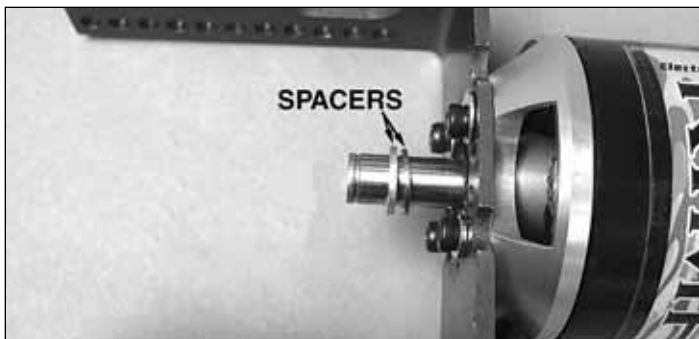

❑ 3. Slide two spacers over the motor shaft followed by the collar. Apply a drop of threadlocker to the set screw, and then tighten the set screw against the shaft.

❑ 4. Mount the rear half of the motor mount to the firewall with four 8-32 x 1" [25mm] SHCS, #8 flat washers and #8 lock washers.

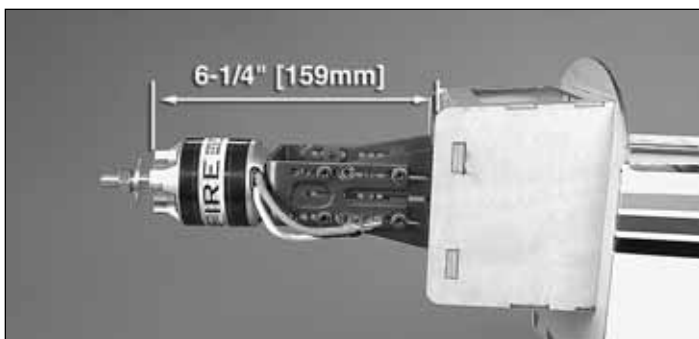

❑ 5. Re-install the front half of the motor mount to the rear half of the mount that has been installed on the firewall. Position the motor so the distance from the front of the **firewall** to the front of the prop adapter drive washer is 6-1/4" [159mm].

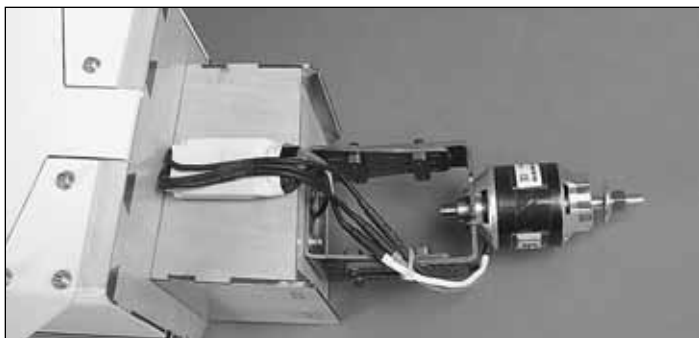

❑ 6. Mount the ESC on the bottom of the firewall box following the instructions that come with the ESC. **Note:** At

the time this manual was written, changes were being made to the appearance of the ESC. Your ESC may not look the same as the one in the photo.



❑ 7. When installing the batteries for the motor, you can hold them in place with the Velcro® provided in the kit. **Note:** If you will be installing the NiMH batteries, you can see that they extend into the radio compartment area. We have made provision for this and it will be addressed in the radio installation section of this manual. Skip ahead to page 16, step 11.

Install the Glow Engine, Fuel Tank & Throttle Servo



❑ 1. Cut the tabs from the engine mount.

❑ 2. Install the engine mount to the firewall using four each, 8-32 x 1" [25mm] SHCS, #8 flat washers and #8 lock washers. When installing the mount, use your engine to determine the spacing needed for the mounting rails.

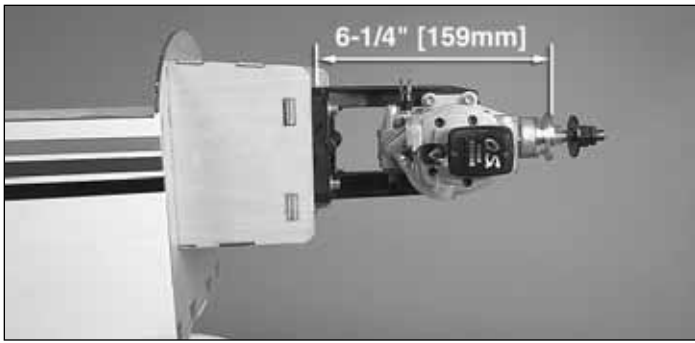

❑ 3. Position the engine in the mount so the distance from the front of the firewall to the front of the drive washer measures 6-1/4" [159mm]. Mark the location of the engine on the mount. The Great Planes Dead Center™ Hole Locator (GPMR8130) works well for this. Drill through the marks you have made on the engine mount with a #29 or 9/64" [3.6mm] drill bit. Tap each of the holes with an 8-32 tap.

❑ 4. Install the engine onto the mount with four each, 8-32 x 1" [25mm] SHCS, #8 flat washers and # 8 lock washers.

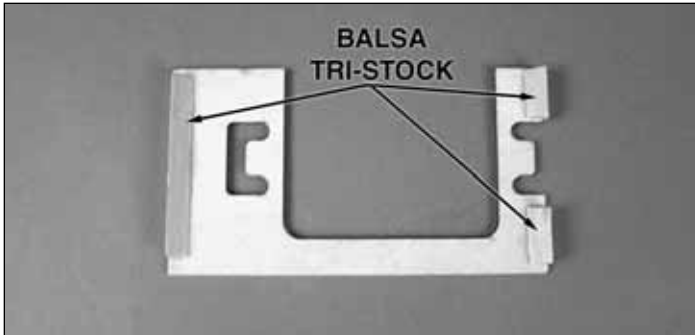

❑ 5. From the 12" [305mm] balsa tri-stock cut three lengths to fit the back of the fuel tank former. Glue them in position as shown.



❑ 6. Glue the fuel tank former in position as shown.

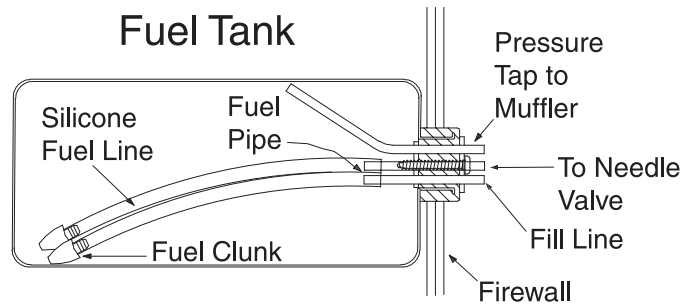

❑ 7. Install silicone fuel tubing (not supplied) onto the aluminum tubes from the fuel tank. The line with the fuel clunk will feed to the fuel inlet at the needle valve. The vent will attach to the pressure tap on the muffler and the third line will be used for filling and de-fueling the fuel tank. Insert the fuel plug included in this kit into the fill line. If you choose to use some kind of an external fuel valve, follow the instructions with your particular brand of fuel valve.

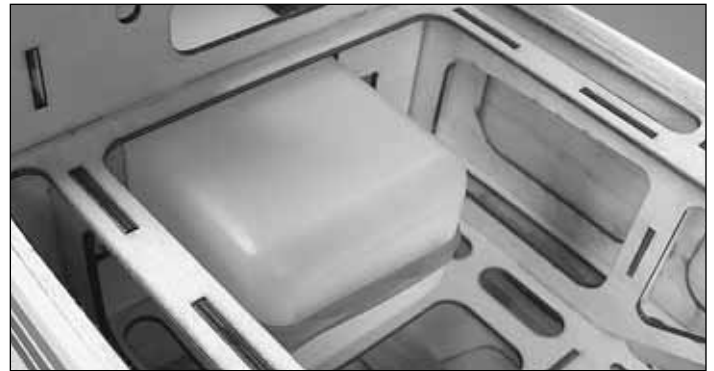

❑ 8. Install the fuel tank into the fuselage with the neck of the tank through the firewall. Hold the fuel tank in position with two #64 rubber bands.

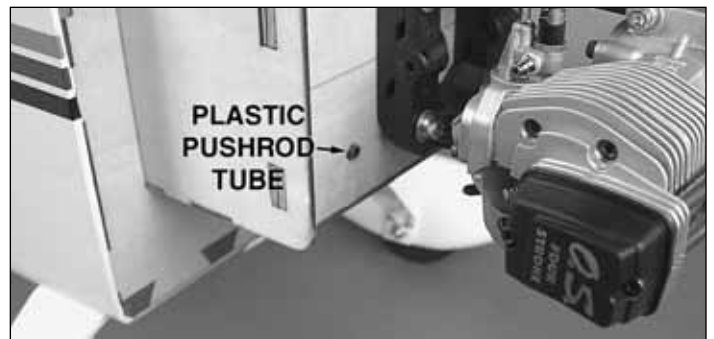

❑ 9. Mark the location on the firewall where the throttle pushrod will pass through. Drill a 3/16" [4.8mm] hole on that mark. Locate the 12" [305mm] plastic pushrod tube. Cut it to a length of 8" [203mm]. Roughen one end of the tube with 220-grit sandpaper. Install the un-sanded end of the pushrod tube into the front of the firewall through the hole you drilled in the firewall and through the hole inside the fuselage, in the fuselage former. Apply CA to the roughened end of the plastic tube, gluing it into the firewall.

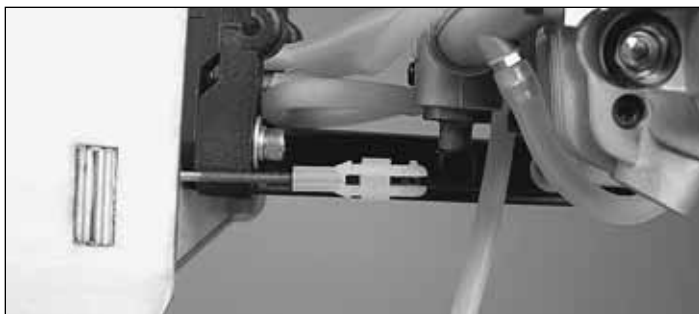

❑ 10. Locate a .074 x 36" [914mm] pushrod wire. Cut it to a length of 12" [305mm]. Screw a nylon clevis onto the threaded end of the wire approximately 20 turns. Slide a silicone clevis keeper onto the clevis. Slide the wire into the pushrod tube, attach the clevis to throttle and slide the clevis keeper over the clevis.

Note: If you will be installing an electric motor you will have to make a few modifications to the servo and receiver trays. Steps 13 to 15 show the required changes. If you are installing the glow engine skip ahead to step 16.

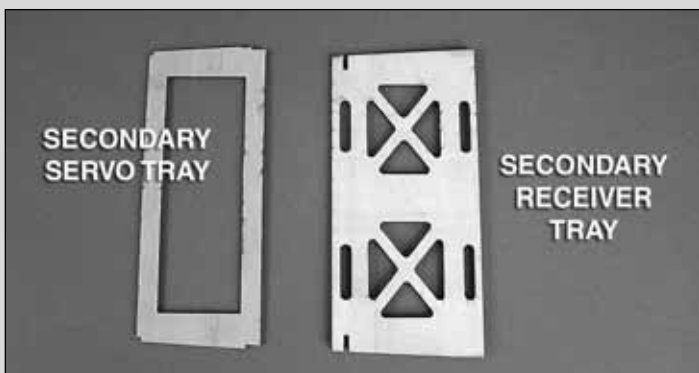

❑ 11. To prevent any interference between the receiver and the motor, ESC and batteries we have provided a secondary receiver/battery tray and a secondary servo tray. The receiver/battery tray should be used if you are using LiPo batteries or NiMH batteries. The secondary servo tray is only needed if you will be using the NiMH batteries. The NiMH are too long to allow the servos to be used in the primary servo location and the extra weight of those batteries requires the servos to be located further aft to help with the weight and balance. Locate the plywood receiver tray and the plywood servo tray.

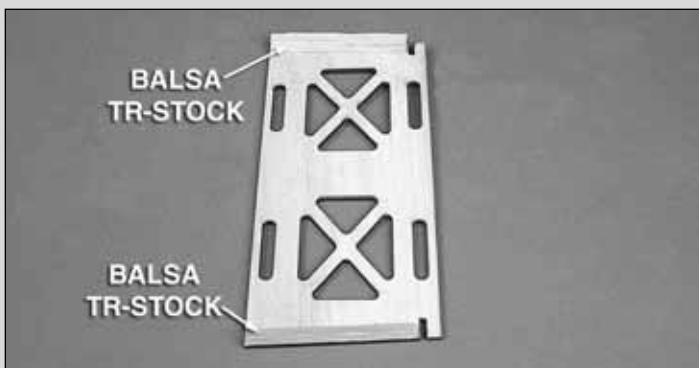

❑ 12. From the 12" [305mm] balsa tri-stock cut two 2-1/2" pieces and glue them to the receiver/battery tray as shown.

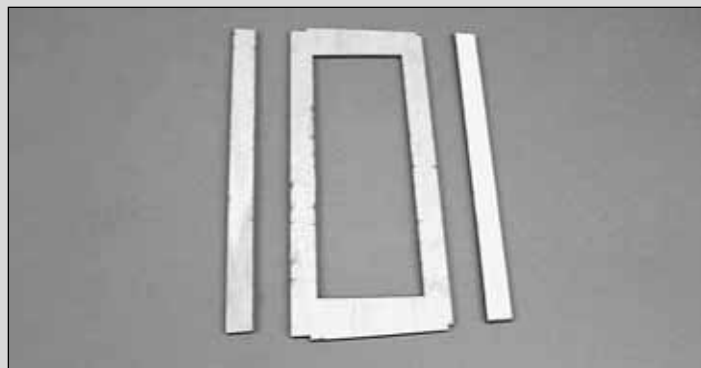

❑ 13. If you will be installing the secondary servo tray, glue the plywood doublers to the tray as shown.



❑ 14. Glue the receiver/battery tray in place as shown. If you will be using the secondary servo tray, glue it in place in the notches in the side of the fuselage.



❑ 15. **Important!!** This step is only required if you are installing the NiMH battery pack. Skip this step if you will be using LiPo batteries. Cut the plastic pushrods at the locations shown. (There is not a specific location. They just need to be approximate.)

If you will be installing LiPo batteries skip ahead to, **“Install the Radio, Servos, and Pushrods.”** Follow the instructions as they are written. The only difference will be that you should install the battery and receiver into the rear tray that you just installed.

If you are installing NiMH batteries skip ahead to, **“Install the Radio, Servos, and Pushrods.”** Follow the instructions as they are written with the following two exceptions. When you are instructed to install the receiver and battery, install them in the secondary receiver/battery tray you just installed. When you are instructed to install the servos, install them into the secondary servo tray you just installed.

Install the Radio, Servos & Pushrods



1. Locate three .095" x 36" [.095" x 914mm] pushrod wires threaded on one end. Slide two of the wires into the two plastic pushrod tubes in the center of the fuselage. Push them into the tubes until they touch the covering on the outside of the fuselage. Cut the covering away to allow the wire to exit the fuselage side. Do this for both sides of the fuselage.



2. Install a threaded metal clevis onto the threaded end of each of the pushrod wires approximately 20 turns.

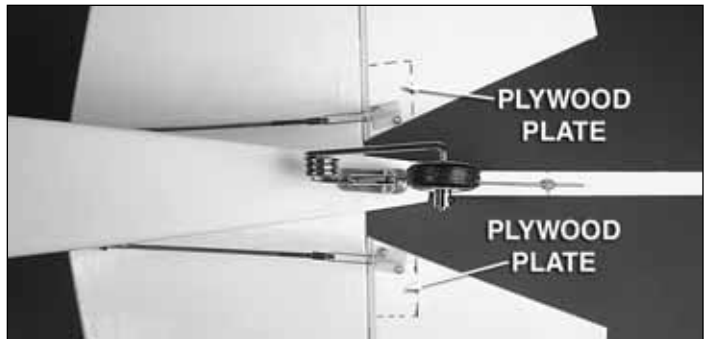

3. Connect a nylon control horn onto each of the two clevises. Position the control horns on the elevators, positioning them on the plywood plates the same way as

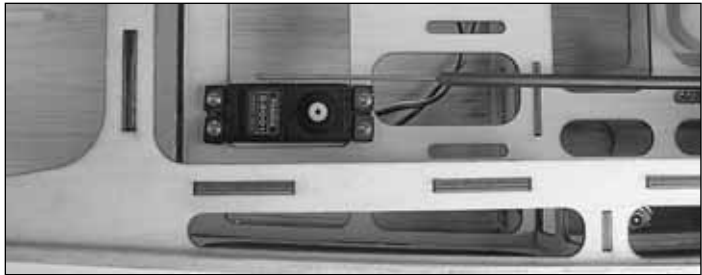

16. Install the throttle servo into the tray in the fuselage. Drill a 1/16" [1.6mm] hole through each of the mounting holes in the servo. Install and then remove a servo mounting screw into each of the holes you have drilled. Apply a couple of drops of thin CA into the holes to harden the threads. After the glue has hardened, install your servo. (Note: Included in the kit are four 1/8" x 5/16" x 3/4" [3 x 8 x 19mm] plywood spacers. Later in the manual when you are instructed to install the battery and receiver, you may need to use the spacers to raise the throttle servo to provide enough room for the battery. Your choice of battery will determine whether you need to use the spacers or not.)

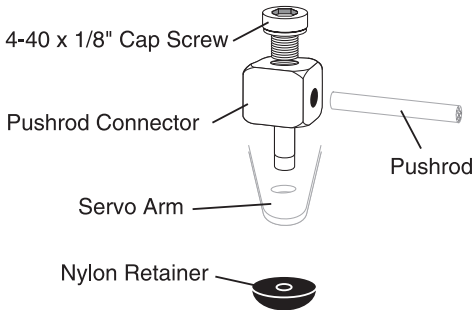
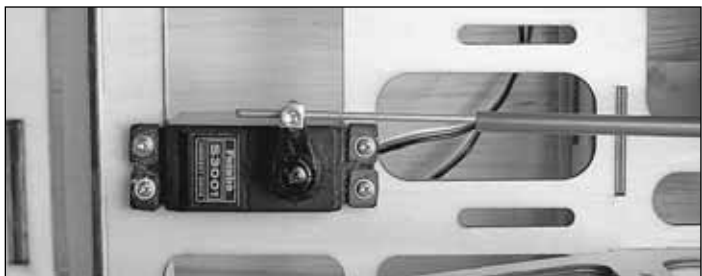

17. Install a brass screw-lock pushrod connector and nylon retainer to the servo arm. Slide it onto the pushrod wire, center the servo, install the servo arm onto the servo, and then install the servo screw into the servo and a 6-32 x 1/8" [3mm] SHCS into the screw-lock pushrod connector.

you did with the ailerons. Mark the location for the screw holes. On the marks, drill through the plywood plate with a 1/16" [1.6mm] drill bit. Drill only through the plate, not through the elevator! Secure the control horn to the elevator with two #2 x 3/8" [9.5mm] SMS.

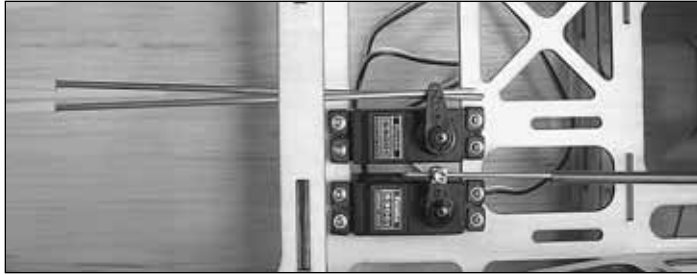

❑ 4. Position the elevator servo in the servo tray so that the servo arm is just above the elevator pushrod wires. (**Note:** Remember if you are doing the electric motor installation with NiMH batteries you should be installing this into the secondary servo tray you installed.)



❑ 5. Remove the left elevator pushrod wire from the fuselage.



❑ 6. Install a 4-40 solder clevis into the outer hole of the servo arm. Center the right elevator and center the servo. Make a mark on the wire indicating where the wire needs to be cut. Remove the clevis from the servo arm and remove the pushrod wire from the fuselage.

❑ 7. Cut the pushrod on the mark you made. Solder the clevis to the wire using the "Expert Tip" below.



HOW TO SOLDER

A. Use denatured alcohol or other solvent to thoroughly clean the pushrod. Use coarse sandpaper to roughen the end of the pushrod where it is to be soldered.



B. Apply a few drops of soldering flux to the end of the pushrod. Position the clevis so that 1/8" [3.2mm] of the pushrod protrudes into the open area of the clevis.

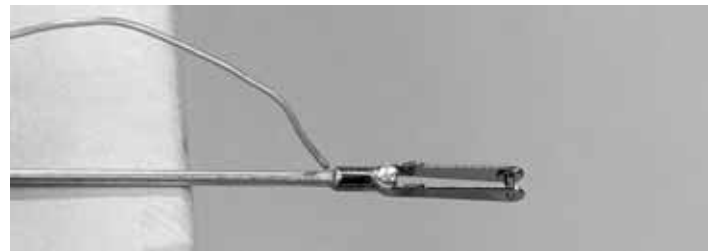

C. Simultaneously heat the clevis and pushrod. Apply Silver Solder (GPMR8070) to the joint. The heat of the parts being soldered should melt the solder, thus allowing it to flow.

D. Immediately after the solder has solidified, but while it is still hot, carefully use a cloth to quickly wipe off the flux before it hardens. **Important:** After the joint cools, coat with oil to prevent rust. **Note:** Do not use the acid flux that comes with the Silver Solder for electrical soldering.



E. This is what a properly soldered clevis looks like; shiny solder with good flow, no blobs, flux removed.



❑ 8. Remove the threaded clevis from both of the elevator pushrod wires. Slide a silicone clevis keeper onto the

elevator pushrod wire you soldered the clevis to followed by two 5/32" [4mm] wheel collars. Then, insert the wire into the tube. Attach the clevis to the servo arm and slide the clevis keeper over the clevis.



❑ 9. On the threaded end of the wire, thread a 4-40 nut and the clevis onto the wire. Slide a clevis keeper over the clevis. Center the elevator servo and the right elevator. Adjust the clevis as needed until the clevis pin is aligned with the hole in the control horn. Attach the clevis to the control horn, and then tighten the 4-40 nut against the clevis. Apply a drop of threadlocker to the nut before tightening it against the clevis. Slide the clevis keeper over the clevis.

❑ 10. On the left elevator pushrod wire thread a 4-40 nut and the clevis onto the wire. Slide a clevis keeper over the clevis. Slide the wire into the fuselage, and then attach the clevis to the control horn. Apply a drop of threadlocker to the nut before tightening it against the clevis. Slide the clevis keeper over the clevis.

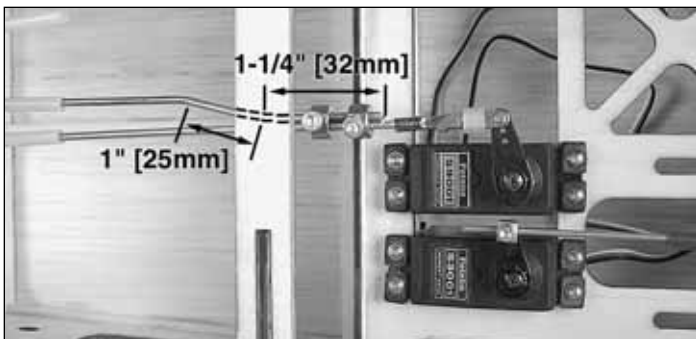

❑ 11. Bend the left elevator pushrod wire as shown. Cut off the excess wire from the left pushrod and slide the wheel collars over both of the pushrod wires. Center the servo and center the left elevator. Install a 6-32 x 1/4" [6mm] SHCS into each of the wheel collars, tightening them against the pushrod wires. Be sure to use a drop of threadlocker on each of the screws.

❑ 12. Slide the remaining pushrod wire into the remaining pushrod tube in the fuselage. Push it into the tube until it touches the covering on the outside of the fuselage. Cut the covering away to allow the wire to exit the fuselage side. Remove the wire from the tube.

❑ 13. Install a threaded metal clevis onto the threaded end of the remaining pushrod wire approximately 20 turns.

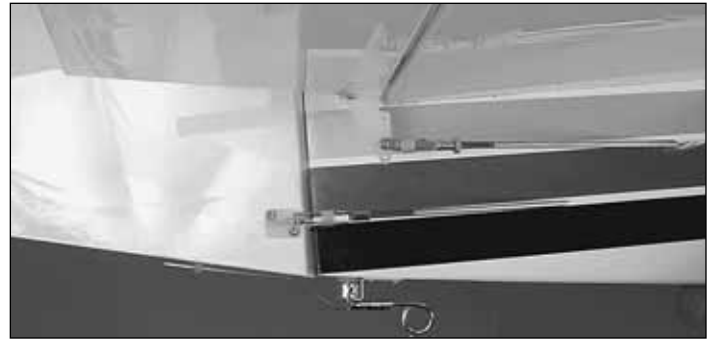

❑ 14. Connect a nylon control horn onto the clevis. Slide the pushrod wire into the fuselage. Position the control horn on the rudder, positioning it on the plywood plate the same way you did with the elevators. Mark the location for the screw holes. On the marks, drill through the plywood plate with a 1/16" [1.6mm] drill bit. Drill only through the plate, not through the rudder! Secure the control horn to the rudder with two #2 x 3/8" [9.5mm] SMS.

❑ 15. Position the rudder servo in the servo tray (remember if you are doing the electric motor installation with NiMH batteries you should be installing this into the secondary servo tray you installed) so that the servo arm is just above the rudder pushrod wire.

❑ 16. Using the same technique used for the elevator, install a 4-40 solder clevis into the outer hole of the servo arm. Center the rudder and center the servo. Make a mark on the wire indicating where the wire needs to be cut. Remove the clevis from the servo arm and remove the pushrod wire from the fuselage.

❑ 17. Cut the pushrod on the mark you made. Solder the clevis to the wire using the same technique used for the elevator.

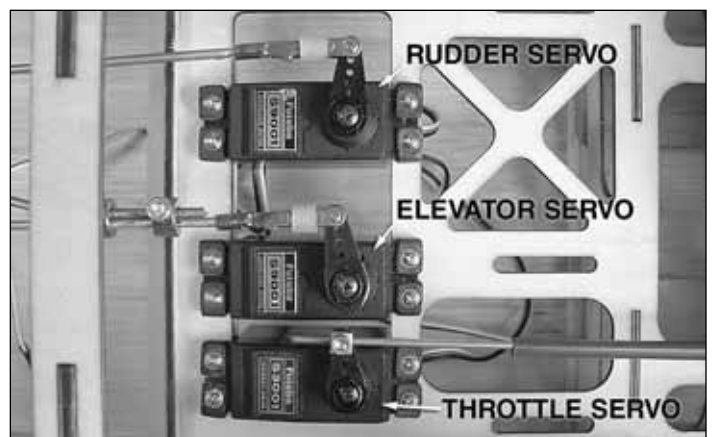

❑ 18. Remove the threaded clevis from rudder pushrod wire. Slide a silicone clevis keeper onto the rudder pushrod wire, and then insert the pushrod wire back into the tube. Attach the clevis to the servo arm and slide the clevis keeper over the clevis.

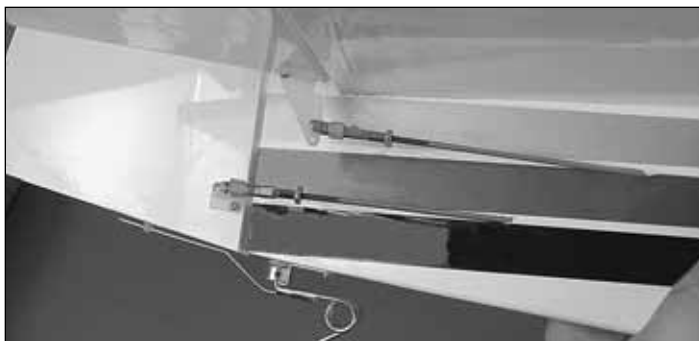

❑ 19. On the threaded end of the wire thread a 4-40 nut and the clevis onto the wire. Slide a clevis keeper over the clevis. Center the rudder servo and the rudder. Adjust the clevis as needed until the clevis pin is aligned with the hole in the control horn. Attach the clevis to the control horn. Then tighten the 4-40 nut against the clevis. Apply a drop of threadlocker to the nut before tightening it against the clevis. Slide the clevis keeper over the clevis.



❑ 20. Install a strip of Velcro through the slots in the servo tray to hold the receiver in place. Place the receiver on 1/4" [6mm] foam. Tighten the Velcro around the receiver.

❑ 21. Route the antenna wire into the antenna tube in the bottom of the fuselage. The antenna tube is longer than the receiver antenna; the antenna will not exit the fuselage. Once the antenna is fully installed in the antenna tube, apply a small piece of tape to the antenna and tube to keep the antenna from sliding out of the antenna tube.

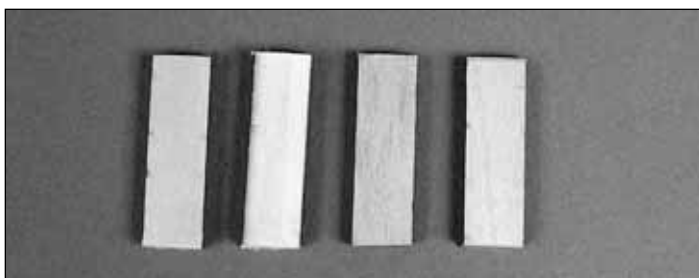

❑ 22. Place the battery on a piece of 1/4" [6mm] foam and strap it in place with Velcro. If the receiver battery does not fit under the throttle linkage, raise the throttle servo by gluing 1/8" x 5/16" x 3/4" [3 x 8 x 19mm] plywood spacers under the servo. Then re-mount the servo.

❑ 23. Install a switch harness and charge jack to the fuselage. Connect the switch to the battery. Be sure to use heat-shrink tubing or tape to be sure the battery to switch connection is secure.

❑ 24. Plug the servos into the receiver following the instructions that came with your radio system. Make adjustments to the position of the servo arms as needed.

Assemble the Canopy

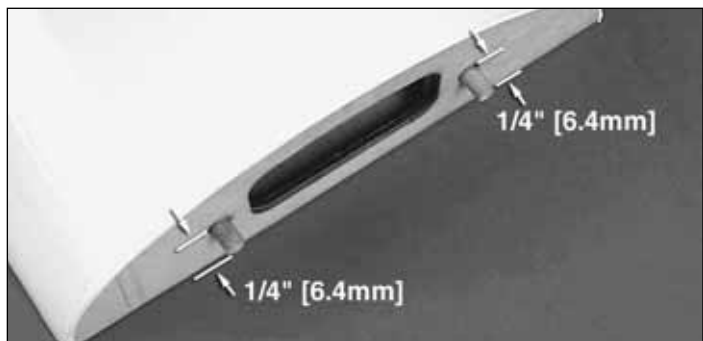

❑ 1. Locate and glue the two 1/4" x 5/8" [6 x 16mm] dowels into the front of the canopy base. When properly installed approximately 1/4" [6mm] of the dowel will extend from the front of the canopy base.

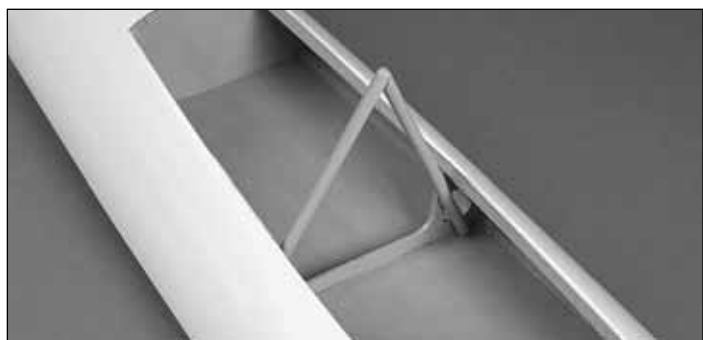

❑ 2. Locate and glue the turn-over post to the front side of the middle former.

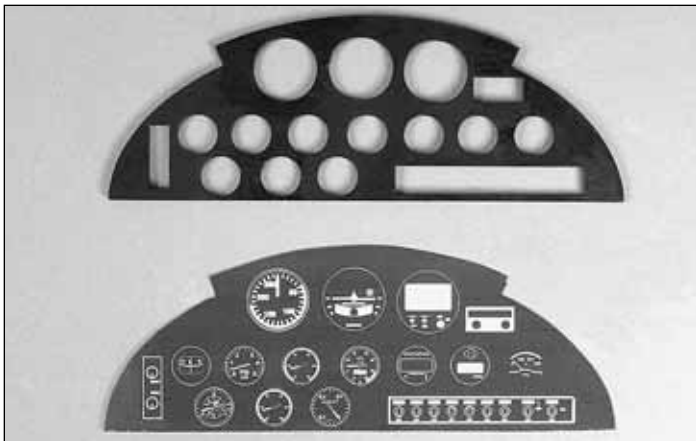

3. Cut the instrument panel decal from the decal sheet and locate the plywood instrument panel. Glue the decal to the back of the plywood instrument panel. After the glue has dried, glue the panel into the front of the cockpit.



4. If you will be installing a pilot, do this now. We used a 1/4-scale pilot. Secure the pilot into place using glue or screws.



5. Place the canopy onto the canopy base and trace the shape of the canopy. Cut a small strip of covering from inside the lines you have drawn. Glue the canopy to the canopy base with RC56 canopy glue.



6. Place the completed canopy onto the top of the fuselage. Secure it to the fuselage with two 8-32 x 1/2" [13mm] MS and #4 flat washers.

Install the Cowl

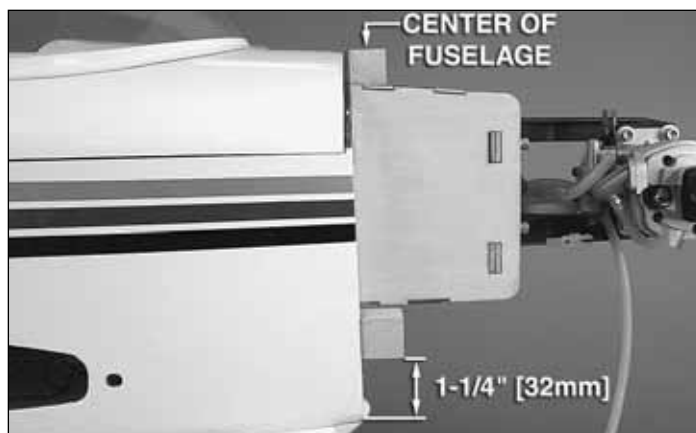

1. Locate three 3/4" x 3/4" x 3/4" [19 x 19 x 19mm] hardwood blocks. Epoxy one block to the top center of the firewall and one on each side as shown, flush with the sides of the fuse.

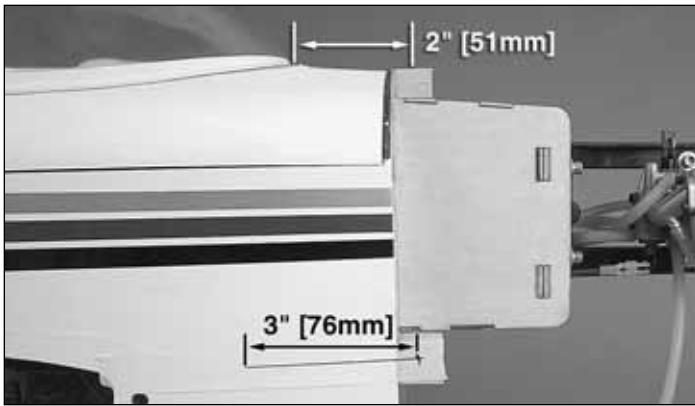

2. Place 4" [102mm] of masking tape over each block extending back to the fuselage. Measure back from the center of the two blocks on the sides of the fuselage 3" [76mm] and 2" [51mm] back from the center of the top block. Draw a reference line on the tape as shown.



3. Slide the cowl onto the fuselage. Position the cowl so that it is centered on the engine crankshaft and so there is approximately 1/8" [3mm] clearance between the front of the cowl and the spinner backplate. Measure forward from your reference lines 3" [76mm] on the sides and 2" [51mm] on the top. Mark the cowl and drill a 3/32" [2.4mm] hole through each of the marks. Secure the cowl to the fuselage with three #4 x 1/2" [13mm] SMS. After mounting the cowl remove the screws and put a couple of drops of thin CA into the holes to harden the threads. Allow the glue to harden before re-installing the cowl.

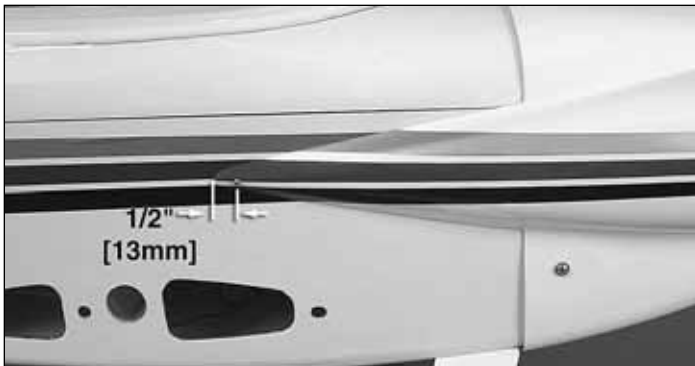

4. This step is optional. The cowl fits closely to the fuselage sides but this step will assure that the tip of the cowl stays tight to the fuselage sides and will help to make a good alignment with the accent stripes on the cowl and fuselage. Measure forward from the tip of the cowl 1/2" [13mm]. Drill a 1/16" [1.6mm] hole through the tip of the cowl

and through the fuselage side. Remove the cowl. Drill a 3/32" [2.4mm] clearance hole through the hole in the tip of the cowl you just made. (You may wish to consider countersinking this hole to allow the head of the #2 screw to set into the cowl. This portion of the cowl has a resin build up behind it so there is plenty of material to allow for countersinking the head.) Apply a couple of drops of thin CA into the hole in the fuselage to harden the threads. Re-install the cowl using the #4 mounting screws.

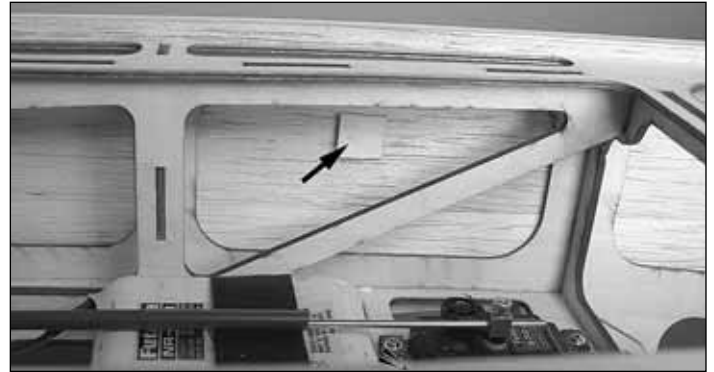

5. Look inside the fuselage to see where the screw has come through. Glue a 3/32" x 1/2" x 1/2" [2 x 13 x 13mm] plywood plate over the hole. Using a 1/16" [1.6mm] re-drill through the hole, drilling through the plywood plate. Screw the two #2 x 3/8" [9.5mm] SMS through the tips of the cowl and into the plywood plates.

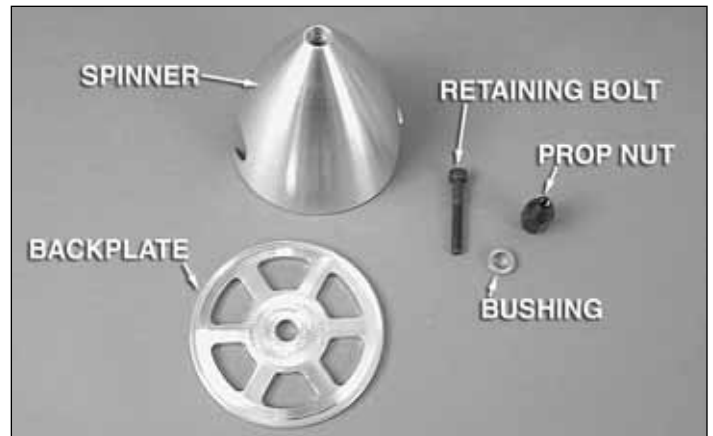

6. Locate the spinner components. Install the bushing into the backplate. If your engine has a larger crankshaft diameter than the backplate or the bushing, you will have to drill out the backplate to fit your engine's crankshaft.

GET THE MODEL READY TO FLY

Check the Control Directions

1. Turn on the transmitter and receiver and center the trims. If necessary, remove the servo arms from the servos and reposition them so they are centered. Reinstall the screws that hold on the servo arms.
2. With the transmitter and receiver still on, check all the control surfaces to see if they are centered. If necessary, adjust the clevises on the pushrods to center the control surfaces.

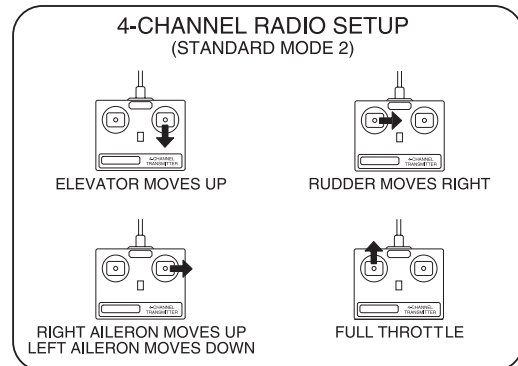

3. Make certain that the control surfaces and the carburetor respond in the correct direction as shown in the diagram. If any of the controls respond in the wrong direction, use the servo reversing in the transmitter to reverse the throttle and ESC servos connected to those controls. Be certain the control surfaces have remained centered. Adjust if necessary. **Note:** For electric motor installation hookup the ESC for throttle control.

Set the Control Throws



Use a Great Planes AccuThrow™ (or a ruler) to accurately measure and set the control throw of each control surface as indicated in the chart that follows. If your radio does not have dual rates, we recommend setting the throws at the **low rate** setting.

Note: The throws are measured at the **widest part** of the elevators, rudder and ailerons.

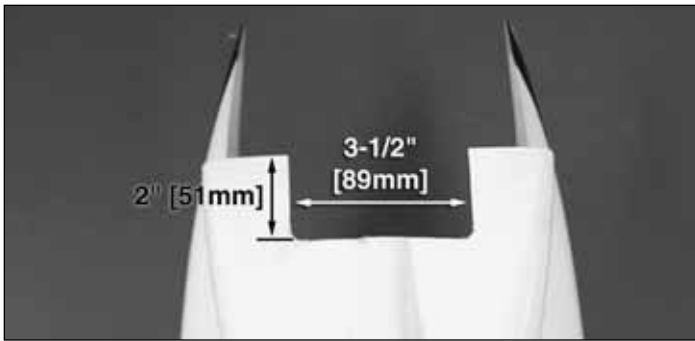

7. Cut the bottom of the cowl as shown to provide exhaust air to properly cool the engine. This step is required for both a glow installation and the installation of an electric motor and ESC.

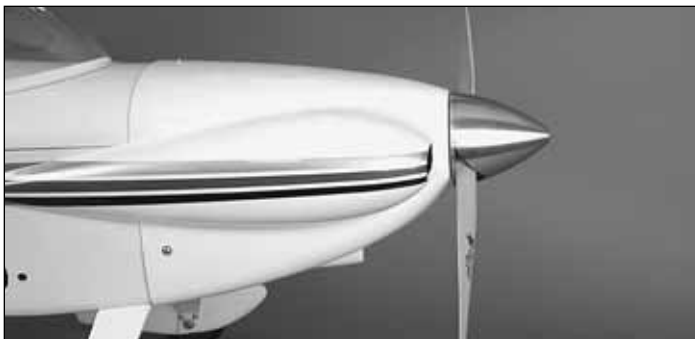

8. Install the spinner and propeller appropriate for your engine. Make any cut outs required for access to the glow plug, needle valve, etc. If you choose to make a hole in the side of the cowl for access to the glow plug, you will have to use a long neck glow starter. Standard length glow starters are too short to reach through the cowl cheek. You may wish to install a remote glow starter as we did to eliminate the need for a hole for the glow starter.

Apply the Decals

1. Use the box photos as your guide for the installation of the decals.
2. Use scissors or a sharp hobby knife to cut the decals from the sheet.
3. Be certain the model is clean and free from oily fingerprints and dust. Prepare a dishpan or small bucket with a mixture of liquid dish soap and warm water—about one teaspoon of soap per gallon of water. Submerge the decal in the soap and water and peel off the paper backing. **Note:** Even though the decals have a “sticky-back” and are not the water transfer type, submersing them in soap and water allows accurate positioning and reduces air bubbles underneath.
4. Position decal on the model where desired. Holding the decal down, use a paper towel to wipe most of the water away.
5. Use a piece of soft balsa or something similar to squeegee remaining water from under the decal. Apply the rest of the decals the same way.

These are the recommended control surface throws:

	High Rate	Low Rate
ELEVATOR:	1" [25mm] up 1" [25mm] down	5/8" [16mm] up 5/8" [16mm] down
RUDDER:	2-3/4" [70mm] right 2-3/4" [70mm] left	1-3/4" [44mm] right 1-3/4" [44mm] left
AILERONS:	1-1/2" [38mm] up 1-1/2" [38mm] down	3/4" [19mm] up 3/4" [19mm] down
FLAPS:	1-1/8" [28mm] down 3/4" [19mm] down	

IMPORTANT: The RV-4 has been **extensively** flown and tested to arrive at the throws at which it flies best. Flying your model at these throws will provide you with the greatest chance for successful first flights. If, after you have become accustomed to the way the RV-4 flies, you would like to change the throws to suit your taste, that is fine. However, too much control throw could make the model difficult to control, so remember, "more is not always better."

Balance the Model (C.G.)

More than any other factor, the **C.G.** (balance point) can have the **greatest** effect on how a model flies, and may determine whether or not your first flight will be successful. If you value this model and wish to enjoy it for many flights, **DO NOT OVERLOOK THIS IMPORTANT PROCEDURE.** A model that is not properly balanced will be unstable and possibly unflyable.

At this stage the model should be in ready-to-fly condition with all of the systems in place including the engine, landing gear, covering and paint, and the radio system.

□ 1. Use a felt-tip pen or 1/8" [3mm]-wide tape to accurately mark the C.G. on the top of the wing on both sides of the fuselage. The C.G. is located 4-3/8" [111mm] back from the LE of the wing.

This is where your model should balance for the first flights. Later, you may wish to experiment by shifting the C.G. up to 3/8" [9.5mm] forward or 1" [25mm] back to change the flying characteristics. Moving the C.G. forward may improve the smoothness and stability, but the model may then require more speed for takeoff and make it more difficult to slow for landing. Moving the C.G. aft makes the model more maneuverable, but could also cause it to become too difficult to control. In any case, **start at the recommended balance point** and do not at any time balance the model outside the specified range.



□ 2. With the wing attached to the fuselage, all parts of the model installed (ready to fly) and an empty fuel tank, place the model upside-down on a Great Planes CG Machine, or lift it upside-down at the balance point you marked.

□ 3. If the tail drops, the model is "tail heavy" and the battery pack and/or receiver must be shifted forward or weight must be added to the nose to balance. If the nose drops, the model is "nose heavy" and the battery pack and/or receiver must be shifted aft or weight must be added to the tail to balance. If possible, relocate the battery pack and receiver to minimize or eliminate any additional ballast required. If additional weight is required, nose weight may be easily added by using a "spinner weight" (GPMQ4645 for the 1 oz. [28g] weight, or GPMQ4646 for the 2 oz. [57g] weight). If spinner weight is not practical or is not enough, use Great Planes (GPMQ4485) "stick-on" lead. A good place to add stick-on nose weight is to the firewall (don't attach weight to the cowl—it is not intended to support weight). Begin by placing incrementally increasing amounts of weight on the bottom of the fuse over the firewall until the model balances. Once you have determined the amount of weight required, it can be permanently attached. If required, tail weight may be added by cutting open the bottom of the fuse and gluing it permanently inside.

Note: Do not rely upon the adhesive on the back of the lead weight to permanently hold it in place. Over time, fuel and exhaust residue may soften the adhesive and cause the weight to fall off. Use #2 SMS, RTV silicone or epoxy to permanently hold the weight in place.

□ 4. **IMPORTANT:** If you found it necessary to add any weight, recheck the C.G. after the weight has been installed.

Balance the Model Laterally

□ 1. With the wing level, have an assistant help you lift the model by the engine propeller shaft and the bottom of the fuse under the TE of the fin. Do this several times.

□ 2. If one wing always drops when you lift the model, it means that side is heavy. Balance the airplane by adding weight to the other wing tip. **An airplane that has been laterally balanced will track better in loops and other maneuvers.**

PREFLIGHT

Identify Your Model

No matter if you fly at an AMA sanctioned R/C club site or if you fly somewhere on your own, you should always have your name, address, telephone number and AMA number on or inside your model. It is **required** at all AMA R/C club flying sites and AMA sanctioned flying events. Fill out the identification tag on the decal sheet and place it on or inside your model.

Charge the Batteries

Follow the battery charging instructions that came with your radio control system to charge the batteries. You should always charge your transmitter and receiver batteries the night before you go flying, and at other times as recommended by the radio manufacturer.

CAUTION: Unless the instructions that came with your radio system state differently, the **initial** charge on **new** transmitter and receiver batteries should be done for 15 hours **using the slow-charger that came with the radio system**. This will "condition" the batteries so that the next charge may be done using the fast-charger of your choice. If the initial charge is done with a fast-charger the batteries may not reach their full capacity and you may be flying with batteries that are only partially charged.

Balance the Propellers

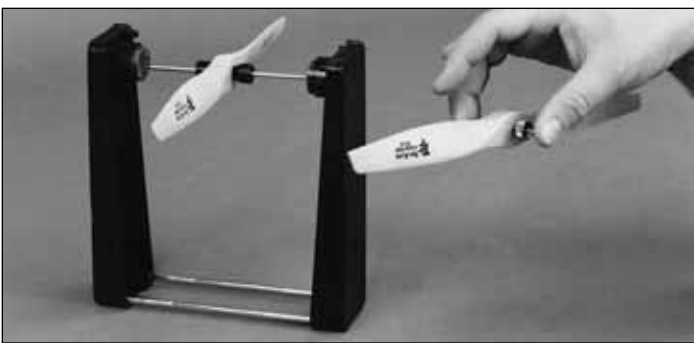

Carefully balance your propeller and spare propellers before you fly. An unbalanced prop can be the single most significant cause of vibration that can damage your model. Not only will engine mounting screws and bolts loosen, possibly with disastrous effect, but vibration may also damage your radio receiver and battery. Vibration can also cause your fuel to foam, which will, in turn, cause your engine to run hot or quit.

We use a Top Flite® Precision Magnetic Prop Balancer (TOPQ5700) in the workshop and keep a Great Planes Fingertip Prop Balancer (GPMQ5000) in our flight box.

Ground Check

If the engine is new, follow the engine manufacturer's instructions to break-in the engine. After break-in, confirm that the engine idles reliably, transitions smoothly and rapidly to full power and maintains full power—indefinitely. After you run the engine on the model, inspect the model closely to make sure all screws remained tight, the hinges are secure, the prop is secure and all pushrods and connectors are secure.

Range Check

Ground check the operational range of your radio before the first flight of the day. With the transmitter antenna collapsed and the receiver and transmitter on, you should be able to walk at least 100 feet away from the model and still have control. Have an assistant stand by your model and while you work the controls, tell you what the control surfaces are doing. Repeat this test **with the engine running** at various speeds with an assistant holding the model, using hand signals to show you what is happening. If the control surfaces do not respond correctly, **do not fly!** Find and correct the problem first. Look for loose servo connections or broken wires, corroded wires on old servo connectors, poor solder joints in your battery pack or a defective cell, or a damaged receiver crystal from a previous crash.

ENGINE SAFETY PRECAUTIONS

Failure to follow these safety precautions may result in severe injury to yourself and others.

Keep all engine fuel in a safe place, away from high heat, sparks or flames, as fuel is very flammable. Do not smoke near the engine or fuel; and remember that engine exhaust gives off a great deal of deadly carbon monoxide. Therefore, **do not run the engine in a closed room or garage.**

Get help from an experienced pilot when learning to operate engines.

Use safety glasses when starting or running engines.

Do not run the engine in an area of loose gravel or sand; the propeller may throw such material in your face or eyes.

Keep your face and body as well as all spectators away from the plane of rotation of the propeller as you start and run the engine.

Keep these items away from the prop: loose clothing, shirt sleeves, ties, scarfs, long hair or loose objects such as pencils or screwdrivers that may fall out of shirt or jacket pockets into the prop.

Use a "chicken stick" or electric starter to start the engine. Do not use your fingers to flip the propeller. Make certain the glow plug clip or connector is secure so that it will not pop off or otherwise get into the running propeller.

Make all engine adjustments from behind the rotating propeller.

The engine gets hot! Do not touch it during or right after operation. Make sure fuel lines are in good condition so fuel will not leak onto a hot engine, causing a fire.

To stop a glow engine, cut off the fuel supply by closing off the fuel line or following the engine manufacturer's recommendations. Do not use hands, fingers or any other body part to try to stop the engine. To stop a gasoline powered engine an on/off switch should be connected to the engine coil. Do not throw anything into the propeller of a running engine.

MOTOR & BATTERY SAFETY PRECAUTIONS

Failure to follow these safety precautions may result in severe injury to yourself and others.

Use safety glasses while running the motor.

Do not run the motor in an area of loose gravel or sand; the propeller may throw such material in your face or eyes.

Keep your face and body as well as spectators away from the plane of rotation of the propeller as you run the motor.

Keep these items away from the prop: loose clothing, shirt sleeves, ties, scarf's, long hair or loose objects such as pencils, or screwdrivers that may fall out of shirt or jacket pockets into the prop.

Always remove the battery from the plane before charging.

Always use a charger designed for the batteries you are using.

Never leave the batteries unattended while charging. If the battery becomes hot, discontinue charging.

AMA SAFETY CODE (excerpts)

Read and abide by the following excerpts from the Academy of Model Aeronautics Safety Code. For the complete Safety Code refer to *Model Aviation* magazine, the AMA web site or the Code that came with your AMA license.

General

1) I will not fly my model aircraft in sanctioned events, air shows, or model flying demonstrations until it has been proven to be airworthy by having been previously, successfully flight tested.

2) I will not fly my model aircraft higher than approximately 400 feet within 3 miles of an airport without notifying the airport operator. I will give right-of-way and avoid flying in the proximity of full-scale aircraft. Where necessary, an observer shall be utilized to supervise flying to avoid having models fly in the proximity of full-scale aircraft.

3) Where established, I will abide by the safety rules for the flying site I use, and I will not willfully and deliberately fly my models in a careless, reckless and/or dangerous manner.

5) I will not fly my model unless it is identified with my name and address or AMA number, on or in the model. **Note:** This does not apply to models while being flown indoors.

7) I will not operate models with pyrotechnics (any device that explodes, burns, or propels a projectile of any kind).

Radio Control

1) I will have completed a successful radio equipment ground check before the first flight of a new or repaired model.

2) I will not fly my model aircraft in the presence of spectators until I become a qualified flier, unless assisted by an experienced helper.

3) At all flying sites a straight or curved line(s) must be established in front of which all flying takes place with the other side for spectators. Only personnel involved with flying the aircraft are allowed at or in the front of the flight line. Intentional flying behind the flight line is prohibited.

4) I will operate my model using only radio control frequencies currently allowed by the Federal Communications Commission.

5) **I will not knowingly operate my model within three miles of any pre-existing flying site except in accordance with the frequency sharing agreement listed (in the complete AMA Safety Code).**

9) Under no circumstances may a pilot or other person touch a powered model in flight; **nor should any part of the model other than the landing gear, intentionally touch the ground, except while landing.**

IMAA SAFETY CODE (excerpts)

Since the RV-4 qualifies as a “giant-scale” model and is therefore eligible to fly in IMAA events, we’ve printed excerpts from the IMAA Safety Code which follows.

What is Giant-Scale?

The concept of large or giant-scale is generally considered to apply to radio controlled model aircraft with minimum wingspans of 80 inches for monoplanes and 60 inches for multi-wing aircraft. Quarter-scale or larger replicas of person-carrying aircraft with proper documentation (minimum 3-view drawing) which do not fit the size requirements will also be permitted.

Section 1.0: SAFETY STANDARD

1.1 Adherence to Code: The purpose of this Safety Code is to provide a structure whereby all participants, including spectators, will be aware of the inherent dangers in the operation of radio controlled aircraft. This code is meant to serve as a minimum guideline to all participants. It is understood that the ultimate responsibility for the safety of any aircraft lies with the owner(s), pilot(s) and spectator(s) involved in any event. It is the responsibility of all participants to exercise caution when operating, or observing the operation of all radio controlled aircraft. The pilot/owner of an aircraft will not be dissuaded from taking whatever steps they deem necessary, in addition to this code, to insure that their aircraft is safe.

1.2 The most current AMA Safety Code in effect is to be observed.

Section 3.0: SAFETY REVIEW

3.4 Flight Testing: All aircraft are to have been flight tested and flight trimmed with a minimum of six (6) flights before the model is allowed to fly at an IMAA Sanctioned event.

3.5 Proof of Flight: The completing and signing of the Declaration section of the Safety Review form (see “**Section 3.2**”) by the pilot (or owner) shall document, as fact, that the noted aircraft has been successfully flight tested and proven airworthy prior to the IMAA event.

Section 4.0: SPOTTER/HELPER

4.1 Spotter/Helper Definition: An assistant to aid the pilot during start-up, and taxing onto the runway. The spotter/helper will assist the pilot in completing a safe flight.

4.2 Each pilot is required to have a spotter/helper at all IMAA sanctioned events. The event Safety Committee should be prepared to assist those pilots who do not have a spotter/helper to make sure that every registered pilot has the opportunity to fly at a sanctioned event.

Section 5.0: EMERGENCY ENGINE SHUT OFF (Kill Switch)

5.1 Magneto spark ignition engines must have a coil-grounding switch on the aircraft to stop the engine. This will also prevent accidental starting of the engine. This switch shall be readily available to both pilot and spotter/helper. This switch is to be operated manually and without the use of the Radio System.

5.2 Engines with battery powered ignition systems must have a switch to turn off the power from the battery pack to disable the engine from firing. This will also prevent accidental starting of the engine. This switch shall be readily available to both pilot and spotter/helper. This switch shall be operated manually and without the use of the Radio System.

5.3 There must also be a means to stop the engine from the transmitter. The most common method is to completely close the carburetor throat using throttle trim, however other methods are acceptable. This requirement applies to all glow/gas ignition engines regardless of size.

Section 6.0: RADIO REQUIREMENTS

6.1 All transmitters must be FCC type certified.

6.2 FCC Technician or higher-class license required for 6 meter band operation only.

The following recommendations are included in the Safety Code not to police such items, but rather to offer basic suggestions for enhanced safety. It is expected that IMAA members will avail themselves of technological advances as such become available, to promote the safety of all aircraft and participants.

Servos need to be of a rating capable to handle the loads that the control surfaces impose upon the servos. Standard servos are not recommended for control surfaces. Servos should be rated heavy-duty ounces of torque. For flight critical control functions a minimum of 45 inch/ounces of torque should be considered. This should be considered a minimum for smaller aircraft and higher torque servos are strongly encouraged for larger aircraft. The use of one servo for each aileron and one for each stabilizer half is strongly recommended. Use of dual servos is also recommended on larger aircraft.

On-board batteries should be, at a minimum, 1000mAh up to 20 lbs., 1200mAh to 30 lbs., 1800mAh to 40 lbs., and 2000mAh over 40 lbs. flying weight. The number and size of servos, size and loads on control surfaces, and added features should be considered as an increase to these minimums. Batteries should be able to sustain power to the on-board radio components for a minimum of one hour total flying time before recharging.

Dependable, redundant and fail safe battery systems are recommended.

The use of anti-glitch devices for long leads is recommended.

There is no maximum engine displacement limit, as it is the position of this body that an underpowered aircraft presents a greater danger than an overpowered aircraft. However, the selections of engine size relative to airframe strength and power loading mandates good discretionary judgment by the designer and builder. Current AMA maximums for engine displacement are 6.0 cu in for two-stroke and 9.6 cu in for four-stroke engines. These maximums apply only to AMA Sanction competition events such as 511, 512, 515 and 520. All non competition events should be sanctioned as Class "C" events, in which these engine size maximums do not apply.

Generally, it is recommended that no attempt should be made to fly a radio controlled model aircraft with a gasoline engine in which the model aircraft weight would exceed twelve (12) pounds per cubic inch of engine displacement (underpowered), or be less than five (5) pounds per cubic inch of engine displacement (overpowered). **Example:** Using a 3 cu in engine, a model would likely be underpowered at an aircraft weight greater than 36 pounds. With the same engine, an aircraft weighing less than 15 pounds would likely be overpowered.

Servo arms and control horns should be rated heavy-duty. Glass filled servo arms and control horns are highly recommended.

Control surface linkages are listed in order of preference:

1. Cable system (pull-pull). A tiller bar is highly recommended along with necessary bracing.

2. Arrow-shaft, fiberglass or aluminum, 1/4" [6.4mm] or 5/16" [8mm] O.D. Bracing every six (6) to ten (10) inches is highly recommended.

3. Tube-in-tube (nyrod). Bracing every few inches is highly recommended. Inner tube should be totally enclosed in outer tube.

4. Hardwood dowel, 3/8" [9.5mm] O.D. Bracing every six (6) to ten (10) inches is highly recommended.

Hinges should be rated heavy-duty and manufactured primarily for use in giant-sized aircraft. Homemade and original design hinges are acceptable if determined to be adequate for the intended use.

Clevis (steel, excluding heavy-duty ball links) and attachment hardware should be heavy-duty 4-40 threaded rod type. 2-56 threaded size rod is acceptable for some applications (e.g. throttle). Clevises must have lock nuts and sleeve (fuel tubing) or spring keepers.

Propeller tips should be painted or colored in a visible and contrasting manner to increase the visibility of the propeller tip arc.

CHECK LIST

During the last few moments of preparation your mind may be elsewhere anticipating the excitement of the first flight. Because of this, you may be more likely to overlook certain checks and procedures that should be performed before the model is flown. To help avoid this, a check list is provided to make sure these important areas are not overlooked. Many are covered in the instruction manual, so where appropriate, refer to the manual for complete instructions. Be sure to check the items off as they are completed.

- 1. Fuelproof all areas exposed to fuel or exhaust residue such as the cowl mounting blocks, wing saddle area, etc.
- 2. Check the C.G. according to the measurements provided in the manual.
- 3. Be certain the battery and receiver are securely mounted in the fuse. Simply stuffing them into place with foam rubber is not sufficient.
- 4. Extend your receiver antenna and make sure it is properly mounted inside the fuselage to keep tension off the solder joint inside the receiver.
- 5. Balance your model *laterally* as explained in the instructions.
- 6. Use thread-locking compound to secure critical fasteners such as the set screws that hold the wheel axles to the struts, screws that hold the carburetor arm (if applicable), screw-lock pushrod connectors, etc.
- 7. Add a drop of oil to the axles so the wheels will turn freely.
- 8. Make sure all hinges are **securely** glued in place.
- 9. Reinforce holes for wood screws with thin CA where appropriate (servo mounting screws, cowl mounting screws, etc.).
- 10. Confirm that all controls operate in the correct direction and the throws are set up according to the manual.
- 11. Make sure there are silicone retainers on all the clevises and that all servo arms are secured to the servos with the screws included with your radio.
- 12. Secure connections between servo wires and Y-connectors or servo extensions, and the connection between your battery pack and the on/off switch with vinyl tape, heat-shrink tubing or special clips suitable for that purpose.
- 13. Make sure any servo extension cords you may have used do not interfere with other systems (servo arms, pushrods, etc.).
- 14. Secure the pressure tap (if used) to the muffler with high temp RTV silicone, thread-locking compound or J.B. Weld.
- 15. Make sure the fuel lines are connected and are not kinked.
- 16. Balance your propeller (and spare propellers).
- 17. Tighten the propeller nut and spinner.
- 18. Place your name, address, AMA number and telephone number on or inside your model.
- 19. Cycle your receiver battery pack (if necessary) and make sure it is fully charged.

- 20. If you are flying this plane with electric power be sure you properly charge the batteries following the instructions with your batteries and charger.
- 20. If you wish to photograph your model, do so before your first flight.
- 21. Range check your radio when you get to the flying field.

FLYING

The RV-4 is a great-flying model that flies smoothly and predictably. The RV-4 does not, however, possess the self-recovery characteristics of a primary R/C trainer and should be flown only by experienced R/C pilots.

Fuel Mixture Adjustments

A fully cowled engine may run at a higher temperature than an un-cowled engine. For this reason, the fuel mixture should be richened so the engine runs at about 200RPM below peak speed. By running the engine slightly rich, you will help prevent dead-stick landings caused by overheating.

CAUTION (THIS APPLIES TO ALL R/C AIRPLANES): If, while flying, you notice an alarming or unusual sound such as a low-pitched “buzz,” this may indicate control surface *flutter*. Flutter occurs when a control surface (such as an aileron or elevator) or a flying surface (such as a wing or stab) rapidly vibrates up and down (thus causing the noise). In extreme cases, if not detected immediately, flutter can actually cause the control surface to detach or the flying surface to fail, thus causing loss of control followed by an impending crash. The best thing to do when flutter is detected is to slow the model **immediately** by reducing power, then land as soon as safely possible. Identify which surface fluttered (so the problem may be resolved) by checking all the servo grommets for deterioration or signs of vibration. Make certain all pushrod linkages are secure and free of play. If it fluttered once, under similar circumstances it will probably flutter again unless the problem is fixed. Some things which can cause flutter are; Excessive hinge gap; Not mounting control horns solidly; Poor fit of clevis pin in horn; Side-play of wire pushrods caused by large bends; Excessive free play in servo gears; Insecure servo mounting; and one of the most prevalent causes of flutter; Flying an over-powered model at excessive speeds.

Takeoff

Before you get ready to takeoff, see how the model handles on the ground by doing a few practice runs at **low speeds** on the runway. Hold “up” elevator to keep the tail wheel on the ground. If necessary, adjust the tail wheel so the model will roll straight down the runway. If you need to calm your nerves before the maiden flight, shut the engine down and

bring the model back into the pits. Top off the fuel, and then check all fasteners and control linkages for peace of mind. Though this airplane has flaps they are not required for takeoff. For your first flight it is recommended you do not use flaps. After the plane has been properly trimmed you may wish to try flaps for takeoff by starting with 1/2 flaps.

Remember to takeoff into the wind. When you're ready, point the model straight down the runway, hold a bit of up elevator to keep the tail on the ground to maintain tail wheel steering, then gradually advance the throttle. As the model gains speed decrease up elevator allowing the tail to come off the ground. One of the most important things to remember with a taildragger is to always be ready to apply **right** rudder to counteract engine torque. Gain as much speed as your runway and flying site will practically allow before gently applying up elevator, lifting the model into the air. At this moment it is likely that you will need to apply more right rudder to counteract engine torque. Be smooth on the elevator stick, allowing the model to establish a **gentle** climb to a safe altitude before turning into the traffic pattern.

Flight

For reassurance and to keep an eye on other traffic, it is a good idea to have an assistant on the flight line with you. Tell him to remind you to throttle back once the plane gets to a comfortable altitude. While full throttle is usually desirable for takeoff, most models fly more smoothly at reduced speeds.

Take it easy with the RV-4 for the first few flights, gradually getting acquainted with it as you gain confidence. Adjust the trims to maintain straight and level flight. After flying around for a while, and while still at a safe altitude with plenty of fuel, practice slow flight and execute practice landing approaches by reducing the throttle to see how the model handles at slower speeds. Add power to see how she climbs as well. Continue to fly around, executing various maneuvers and making mental notes (or having your assistant write them down) of what trim or C.G. changes may be required to fine tune the model so it flies the way you like. You will find that the airplane does very nice loops, spins, inverted flight, etc. The plane has a fairly slow roll rate. Setting up aileron differential either mechanically or through your radio can increase the speed of the roll. Mind your fuel level, but use this first flight to become familiar with your model before landing.

Landing

The flaps on this airplane are very effective but if you are not familiar with flaps it is suggested that you do your first landings without them. The RV-4 lands slowly with or without the use of the flaps. To initiate a landing approach, lower the throttle while on the downwind leg. Allow the nose of the model to pitch downward to gradually bleed off altitude. Continue to lose altitude, but maintain airspeed by keeping the nose down as you turn onto the crosswind leg. Make your final turn toward the runway (into the wind) keeping the nose down to maintain

airspeed and control. Level the attitude when the model reaches the runway threshold, modulating the throttle as necessary to maintain your glide path and airspeed. If you are going to overshoot, smoothly advance the throttle (always ready on the right rudder to counteract torque) and climb out to make another attempt. When you're ready to make your landing flare and the model is a foot or so off the deck, smoothly increase up elevator until it gently touches down. Once the model is on the runway and has lost flying speed, hold up elevator to place the tail on the ground, regaining tail wheel control. When you decide to attempt a landing with flaps be prepared for the airplane to balloon when the flaps are deployed. You can minimize this tendency by setting up a elevator to flap mix. Only 1/16" [1.6mm] or so of down elevator mixed to the flaps will be required to minimize the ballooning.

One final note about flying your model. Have a goal or flight plan in mind for **every** flight. This can be learning a new maneuver(s), improving a maneuver(s) you already know, or learning how the model behaves in certain conditions (such as on high or low rates). This is not necessarily to improve your skills (*though it is never a bad idea!*), but more importantly so you do not surprise yourself by impulsively attempting a maneuver and suddenly finding that you've run out of time, altitude or airspeed. Every maneuver should be deliberate, not impulsive. For example, if you're going to do a loop, check your altitude, mind the wind direction (anticipating rudder corrections that will be required to maintain heading), remember to throttle back at the top, and make certain you are on the desired rates (high/low rates). A flight plan greatly reduces the chances of crashing your model just because of poor planning and impulsive moves. **Remember to think.**

Have a ball! But always stay in control and fly in a safe manner.

GOOD LUCK AND GREAT FLYING!

This model belongs to:					
_____	_____	_____	_____	_____	_____
Name	Address	City, State Zip	Phone number	AMMA number	

Make a copy of this identification tag and put it on or inside your model.

OTHER ITEMS AVAILABLE FROM GREAT PLANES



Futaba® 6EXAS 6-Channel FM Computer Radio
 Updating the popular 6EXA – an excellent introduction to computer systems – the 6EXAS Super adds such refinements as adjustable mixing rates and directions for V-tail and elevons...the ability to transmit in PCM as well as PPM...plus fail-safe and model naming features. The LCD screen definition has also been improved for even easier readability. Even first-time computer radio users can master its programming easily – and there's a lot of programming potential to enjoy. **FUTK56****



ElectriFly™ by Great Planes RimFire™ 50-65-450kV Brushless Out-runner Motor
 ElectriFly RimFire brushless motors are designed and produced with high quality, power, precision and efficiency in mind. The out-runner design eliminates the need for an external gear drive for many applications, reducing cost, all-up weight and complexity. And the RimFire's prop saver design eliminates the need for a prop adapter – simply strap the prop onto the motor with a rubber band and that's it! **GPMG4770**

- Exceptionally high power-to-weight ratio.
- Maximum rated efficiency of 89%
- Extremely strong neodymium "rare earth" magnets for high output torque, with one of the highest temperature ratings in R/C at 302° F (150° C). They won't break down like lower quality magnets.
- Very reliable and virtually maintenance-free. No brushes to wear out. Dual ball bearings are shielded on both sides to keep out dirt and debris.

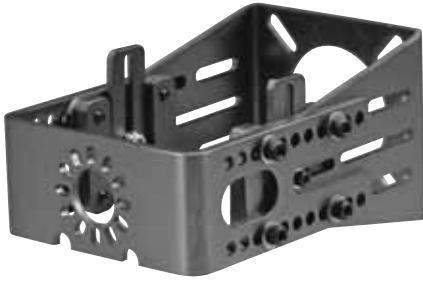

ElectriFly by Great Planes Large Motor Mount [36 mm]

ElectriFly offers a complete line of accessories for electric-powered airplanes, including this motor mount for use with large brushless motors. The mount is made from strong, lightweight aluminum and has hex-head hardware for easy, one-tool adjustment and mounting. The mount is a direct replacement for existing Great Planes glow engine mounts. **GPMG1260**



ElectriFly by Great Planes 3200mAh Power Series LiPo Battery with Balance Connector

Ideal for scale aircraft, bigger sport aerobats, 3D planes, and larger electric models, the Power Series 3200mAh LiPo pack enables you to enjoy the benefits of balancing. The cells are conditioned to last longer, and can be fully charged to 4.20V, ensuring maximum power from the pack. A LiPo Cell Balancer (like ElectriFly's Equinox LiPo Balancer GPM3160) or a Balancing Charger is required. **GPMP0623**

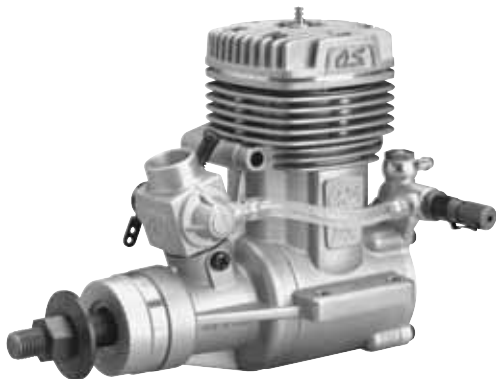

O.S.® .61 FX

Easy to start and maintain, the .61 FX offers 1.9 hp of hard-charging sport power for sizzling aerobatics. Fins on the semi-squared head and 1-piece crankcase carry away performance-killing heat. Dual bearings, a balanced crankshaft and O.S.'s exclusive ABL (Advanced Bimetallic Liner) smooth away friction and vibration, reducing heat, wear and wasted power. The high-speed needle on the 60C

carb is remote mounted for pilot safety, and equipped with an O-ring seal and ratchet spring to hold settings tight against creep. A versatile mounting bracket provides horizontal and vertical mounting options for installation ease. **OSMG0561**



O.S. FS-91 Surpass™ II

With the pumped version of the FS-91 Surpass II 4-stroke engine, the power is undiminished and the dependability and convenience are greater than ever. It features corrosion-resistant plating in critical areas, plus a permanently lubricated, rubber-sealed rear bearing. A reversible carburetor, with the needle valve and mixture control screw on the same side, offers adjustment and installation ease. **OSMG0890**



ElectriFly™ PolyCharge4™

For convenience with multiple LiPo packs, there's the DC PolyCharge4. Each of its four independent outputs can charge a one-to-four cell Lithium-Polymer pack. It's ideal if you don't have the time for one-at-a-time charging – and don't want the expense and hassle of multiple chargers. Each output can handle packs from 300 to 3000mAh. Set the capacity, and PolyCharge4 will automatically set the charge rate to get you started – and use light and sound cues to tell you when your pack is done. **GPMM3015**



