

# MATT CHAPMAN

# 1/3 SCALE

# CAP 580

# ARF

## INSTRUCTION MANUAL

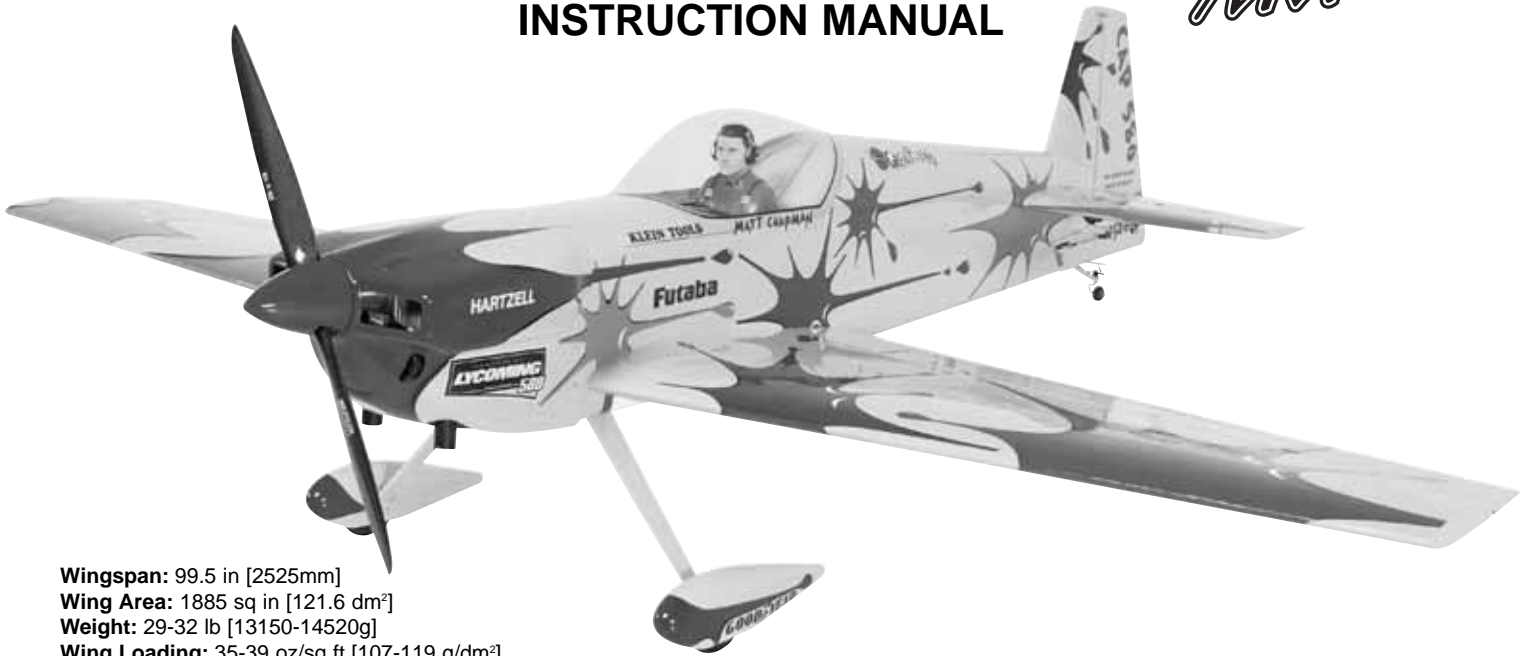

**Wingspan:** 99.5 in [2525mm]

**Wing Area:** 1885 sq in [121.6 dm<sup>2</sup>]

**Weight:** 29-32 lb [13150-14520g]

**Wing Loading:** 35-39 oz/sq ft [107-119 g/dm<sup>2</sup>]

**Length:** 95 in [2415 mm]

**Engine:** 4.2-7.2 cu in [70-120cc]

### WARRANTY

**Great Planes® Model Manufacturing Co.** guarantees this kit to be free from defects in both material and workmanship at the date of purchase. This warranty does not cover any component parts damaged by use or modification. **In no case shall Great Planes' liability exceed the original cost of the purchased kit.** Further, Great Planes reserves the right to change or modify this warranty without notice.

In that Great Planes has no control over the final assembly or material used for final assembly, no liability shall be assumed nor accepted for any damage resulting from the use by the user of the final user-assembled product. By the act of using the user-assembled product, the user accepts all resulting liability.

**If the buyer is not prepared to accept the liability associated with the use of this product, the buyer is advised to return this kit immediately in new and unused condition to the place of purchase.**

To make a warranty claim send the defective part or item to Hobby Services at the address below:

Hobby Services  
3002 N. Apollo Dr. Suite 1  
Champaign IL 61822 USA

Include a letter stating your name, return shipping address, as much contact information as possible (daytime telephone number, fax number, e-mail address), a detailed description of the problem and a photocopy of the purchase receipt. Upon receipt of the package the problem will be evaluated as quickly as possible.

**READ THROUGH THIS MANUAL BEFORE STARTING CONSTRUCTION. IT CONTAINS IMPORTANT WARNINGS AND INSTRUCTIONS CONCERNING THE ASSEMBLY AND USE OF THIS MODEL.**



Champaign, Illinois  
(217) 398-8970, Ext 5  
airsupport@greatplanes.com

## TABLE OF CONTENTS

|  |    |
|--|----|
| INTRODUCTION .....                           | 2  |
| SAFETY PRECAUTIONS .....                     | 3  |
| DECISIONS YOU MUST MAKE .....                | 3  |
| Radio Equipment .....                        | 3  |
| Engine Recommendations.....                  | 4  |
| ADDITIONAL ITEMS REQUIRED .....              | 4  |
| Hardware and Accessories.....                | 4  |
| Adhesives and Building Supplies.....         | 4  |
| Optional Supplies and Tools .....            | 4  |
| Covering Tools .....                         | 4  |
| IMPORTANT BUILDING NOTES.....                | 5  |
| COMMON ABBREVIATIONS .....                   | 5  |
| KIT INSPECTION.....                          | 5  |
| KIT CONTENTS.....                            | 6  |
| ORDERING REPLACEMENT PARTS.....              | 7  |
| ASSEMBLE THE STAB .....                      | 8  |
| Attach the Elevators.....                    | 8  |
| Prepare the Servo Arms .....                 | 9  |
| Mount the Elevator Servos .....              | 9  |
| ASSEMBLE THE WING .....                      | 11 |
| ASSEMBLE THE FUSE.....                       | 12 |
| Install the Tail Gear .....                  | 12 |
| Attach the Rudder.....                       | 13 |
| Install the Rudder Servo(s).....             | 13 |
| Install the Main Gear .....                  | 14 |
| Mount the Engine.....                        | 15 |
| Install the Throttle Servo.....              | 15 |
| Install the Servo Operated Kill Switch ..... | 17 |
| Assemble and Install the Fuel Tank.....      | 18 |
| Mount the Cowl.....                          | 18 |
| FINAL ASSEMBLY .....                         | 19 |
| Mount the Stabilizers .....                  | 19 |
| Finish the Radio Installation .....          | 20 |
| Check the C.G. ....                          | 20 |
| Mount the Wing.....                          | 20 |
| Attach the Canopy .....                      | 21 |
| Apply the Decals.....                        | 21 |
| GET THE MODEL READY TO FLY.....              | 21 |
| Check the Control Directions .....           | 21 |
| Set the Control Throws .....                 | 22 |
| Balance the Model (C.G.) .....               | 22 |
| Balance the Model Laterally .....            | 23 |
| PREFLIGHT .....                              | 23 |
| Identify Your Model.....                     | 23 |
| Charge the Batteries.....                    | 23 |
| Balance Propellers.....                      | 23 |
| Ground Check.....                            | 23 |
| Range Check .....                            | 23 |
| ENGINE SAFETY PRECAUTIONS .....              | 24 |
| AMA SAFETY CODE .....                        | 24 |
| IMAA SAFETY CODE .....                       | 24 |
| CHECK LIST.....                              | 26 |
| FLYING.....                                  | 26 |
| Fuel Mixture Adjustments .....               | 26 |
| Takeoff .....                                | 27 |
| Flight .....                                 | 27 |
| Landing .....                                | 27 |

## INTRODUCTION

The Great Planes 1/3-scale Matt Chapman CAP 580 ARF model is the latest in a long line of amazingly successful full-sized aerobatic aircraft, and this model follows the same tradition of exceptional aerobatic models. Our CAP 580 is carefully designed to model Matt Chapman's impressive competition plane. While aerobatic airplanes are NEVER meant to be trainers, neither do they need to be difficult to fly. In fact, a quality aerobatic airplane is, by definition, simple to fly through basic maneuvers, making the pilot look good and allowing the pilot to focus on the fine points and technicalities of the maneuvers being performed. This model is designed around this basic philosophy, and the resulting performance is outstanding! The CAP 580 is no beginner's airplane, so you should be experienced with gasoline engines and at least a 1.8 cu in [30cc] sized aircraft. This is mainly to ease the transition to being able to judge the size, distance and speed of a model this large. If you do not have experience with gasoline engines, BE CERTAIN to get the assistance of someone with that experience to test fly, trim, and assist you.

For the latest technical updates or manual corrections to the Great Planes 1/3-scale Matt Chapman CAP 580 ARF visit the Great Planes web site at [www.greatplanes.com](http://www.greatplanes.com). Open the "Airplanes" link, then select the Great Planes 1/3-scale Matt Chapman CAP 580 ARF. If there is new technical information or changes to this model a "tech notice" box will appear in the upper left corner of the page.

## AMA

We urge you to join the AMA (Academy of Model Aeronautics) and a local R/C club. The AMA is the governing body of model aviation and membership is required to fly at AMA clubs. Though joining the AMA provides many benefits, one of the primary reasons to join is liability protection. Coverage is not limited to flying at contests or on the club field. It even applies to flying at public demonstrations and air shows. Failure to comply with the Safety Code (excerpts printed in the back of the manual) may endanger insurance coverage. Additionally, training programs and instructors are available at AMA club sites to help you get started the right way. There are over 2,500 AMA chartered clubs across the country. Contact the AMA at the address or toll-free phone number below:



**Academy of Model Aeronautics**  
5151 East Memorial Drive  
Muncie, IN 47302-9252  
Tele. (800) 435-9262  
Fax (765) 741-0057

Or via the Internet at: <http://www.modelaircraft.org>

**IMPORTANT!!!** Two of the most important things you can do to preserve the radio controlled aircraft hobby are to avoid flying near full-scale aircraft and avoid flying near or over groups of people.

## IMAA

This aircraft is ideal for scale aerobatic competition. IMAC events are popular in many areas, and provide a great place to discipline your flying skills, meet great people, and enjoy your hobby all the more with like-minded pilots. Visit [www.mini-iac.com](http://www.mini-iac.com) for details.

If you would like photos of the full-size Great Planes 1/3-scale Matt Chapman CAP 580, or if you would like to study the photos to add more scale details, photo packs are available from:

Bob's Aircraft Documentation  
3114 Yukon Ave  
Costa Mesa, CA 92626

Telephone: (714) 979-8058, Fax: (714) 979-7279  
e-mail: [www.bobsairdoc.com](http://www.bobsairdoc.com)

### PROTECT YOUR MODEL, YOURSELF & OTHERS...FOLLOW THESE IMPORTANT SAFETY PRECAUTIONS

1. Your Great Planes 1/3-scale Matt Chapman CAP 580 ARF should not be considered a toy, but rather a sophisticated, working model that functions very much like a full-size airplane. Because of its performance capabilities, the CAP 580, if not assembled and operated correctly, could possibly cause injury to yourself or spectators and damage to property.

2. You must assemble the model **according to the instructions**. Do not alter or modify the model, as doing so may result in an unsafe or unflyable model. In a few cases the instructions may differ slightly from the photos. In those instances the written instructions should be considered as correct.

3. You must take time to **build straight, true and strong**.

4. You must use an R/C radio system that is in first-class condition, and a correctly sized engine and components (fuel tank, wheels, etc.) throughout the building process.

5. You must correctly install all R/C and other components so that the model operates correctly on the ground and in the air.

6. You must check the operation of the model before **every** flight to insure that all equipment is operating and that the model has remained structurally sound. Be sure to check clevises or other connectors often and replace them if they show any signs of wear or fatigue.

7. If you are not an experienced pilot or have not flown this size and type of model before, we recommend that you get the assistance of an experienced pilot in your R/C club for

your first flights. If you're not a member of a club, your local hobby shop has information about clubs in your area whose membership includes experienced pilots.

8. While this kit has been flight tested to exceed normal use, **it is important** that the modeler understand that aerobatic designs are not race planes, and should not be flown like one. In addition, "more is better" is the **WRONG** philosophy when powering an aerobatic plane. This model has been professionally designed and tested, and the engine range carefully selected for great performance. **We strongly recommend NOT exceeding the recommended engine range**. If the plane will be used for extremely high stress flying outside the aerobatic envelope, such as racing, or if an engine larger than one in the recommended range is used, the modeler is responsible for taking steps to reinforce the high stress points and/or substituting hardware more suitable for the increased stress. It is also important to note that the warranty is void if the engine range is exceeded.

9. **WARNING:** The cowl and wheel pants included in this kit are made of fiberglass, the fibers of which may cause eye, skin and respiratory tract irritation. Never blow into a part (wheel pant, cowl) to remove fiberglass dust, as the dust will blow back into your eyes. Always wear safety goggles, a particle mask and rubber gloves when grinding, drilling and sanding fiberglass parts. Vacuum the parts and the work area thoroughly after working with fiberglass parts.

We, as the kit manufacturer, provide you with a top quality, thoroughly tested kit and instructions, but ultimately the quality and flyability of your finished model depends on how you build it; therefore, we cannot in any way guarantee the performance of your completed model, and no representations are expressed or implied as to the performance or safety of your completed model.

**Remember: Take your time and follow the instructions to end up with a well-built model that is straight and true.**

### DECISIONS YOU MUST MAKE

This is a partial list of items required to finish the Great Planes 1/3-scale Matt Chapman CAP 580 that may require planning or decision making before starting to build. Order numbers are provided in parentheses.

#### Radio Equipment

- 6+ channel radio with:
  - 1-2 standard servos (throttle and kill if applicable)
  - 6 standard size high torque (90+oz/in) servos (2 for elevator and 4 for ailerons)
  - 2 giant scale size high torque (150+ oz/in) servos (used for the rudder – see notes below)

- 2 6" [150mm] servo extensions (HCAM2701 for Futaba) (outer aileron servos)
- 3 Y-harnesses (HCAM2751 for Futaba) (inner aileron servos and rudder servos)
- 2 12" [300mm] servo extensions (HCAM2711 for Futaba) (receiver to each wing)
- 1 24" [610mm] servo extension (HCAM2721 for Futaba) (rudder servos)
- 1 36" [914mm] servo extension (HCAM2726 for Futaba) (elevator servos)
- Receiver battery, 2000mAh minimum

#### **RUDDER SERVO OPTIONS:**

The large size of the rudder on the Giant CAP 580 requires a lot of servo torque. Our testing shows that less than 300 inch ounces of servo power results in rudder "blow back" during certain maneuvers. We have three recommendations to provide adequate performance:

- A. The instructions are written for two quarter scale Futaba S5050 servos. This is the recommended setup.
- B. It is possible to use standard size high torque servos ganged together. There are two servo openings on either side of the fuse for standard size servos. A 150+ oz/in standard size servo can be installed on either side of the fuse. Two 2" [50mm] servo arms will need to be purchased.
- C. Four standard size high torque servos (with a total of 300+ oz/in torque) can be used. This is the least recommended of the setups, and will require modifications not covered in this manual to install the 4 servos.

### **Engine Recommendations**

The recommended engine size range for the Great Planes 1/3-scale Matt Chapman CAP 580 is 4.2-7.2 cu in [80-120cc]. The DA100 provided fantastic power with unlimited vertical and the weight balanced nicely. If an engine in the upper end of the size range is used, remember that this is a scale model that is intended to fly at scale-like speeds, so throttle management must be practiced.

## **ADDITIONAL ITEMS REQUIRED**

### **Hardware and Accessories**

In addition to the items listed in the "Decisions You Must Make" section, following is the list of hardware and accessories required to finish the Great Planes 1/3-scale Matt Chapman CAP 580. Order numbers are provided in parentheses.

- Suitable propeller
- R/C foam rubber 1/2" [13mm] - HCAQ1050
- 3' [900mm] gasoline fuel tubing (GPMQ4135)
- Engine kill switch (GPMG2150) (if using a gas engine)

### **Adhesives and Building Supplies**

In addition to common household tools and hobby tools, this is the "short list" of the most important items required to build the Great Planes 1/3-scale Matt Chapman CAP 580. **Great Planes Pro™ CA and Epoxy glue are recommended.**

- 1 oz. [30g] Thin Pro CA (GPMR6002)
- 1 oz. [30g] Medium Pro CA+ (GPMR6008)
- Pro 30-minute epoxy (GPMR6047)
- Pro 6-minute epoxy (GPMR6045)
- Microballoons (TOPR1090)
- Drill bits: 1/16" [1.6mm], 5/64" [2mm], 3/32" [2.4mm], 7/64" [2.8mm], 1/8" [3.2mm], 9/64" [3.6mm], 5/32" [4mm], 11/64" [4.4mm], 3/16" [4.8mm], 13/64" [5.2mm], 7/32" [5.6mm], 15/64" [6mm], 1/4" [6.4mm], 17/64" [6.7mm], 9/32" [7.1mm]
- Tap handle (GPMR8120)
- Small metal file
- Velcro® hook & loop (1" x 6" [25 x 150mm], GPMQ4480)
- Stick-on segmented lead weights (GPMQ4485)
- #1 Hobby knife (HCAR0105)
- #11 blades (5-pack, HCAR0211)
- Single-edge razor blades (10-pack, HCAR0212)
- Medium T-pins (100, HCAR5150)

### **Optional Supplies and Tools**

Here is a list of optional tools mentioned in the manual that will help you build the Great Planes 1/3-scale Matt Chapman CAP 580.

- 4 oz. [113g] aerosol CA activator (GPMR634)
- CA applicator tips (HCAR3780)
- CA debonder (GPMR6039)
- Epoxy brushes (6, GPMR8060)
- Mixing sticks (50, GPMR8055)
- Mixing cups (GPMR8056)
- Pliers with wire cutter (HCAR0630)
- Robart Super Stand II (ROBP1402)
- Masking tape (TOPR8018)
- Milled fiberglass (GPMR6165)
- Threadlocker thread locking cement (GPMR6060)
- Denatured alcohol (for epoxy clean up)
- Rotary tool such as Dremel®
- Rotary tool reinforced cut-off wheel (GPMR8200)
- Servo horn drill (HCAR0698)
- Laser incidence meter (GPMR4020)
- 36" bar for incidence meter (GPMR4021)

### **Covering Tools**

- Top Flite® MonoKote® sealing iron (TOPR2100)
- Top Flite MonoKote trim seal iron (TOPR2200)
- Top Flite MonoKote heat gun (TOPR2000)

## IMPORTANT BUILDING NOTES

- There are two types of screws used in this kit:

**Sheet metal screws** are designated by a number and a length. For example #6 x 3/4" [19mm]

*This is a number six screw that is 3/4" [19mm] long.*

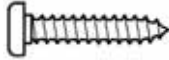

**Machine screws** are designated by a number, **threads per inch**, and a length. For example 4-40 x 3/4" [19mm]

*This is a number four screw that is 3/4" [19mm] long with forty threads per inch.*

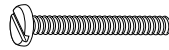

- When you see the term **test fit** in the instructions, it means that you should first position the part on the assembly **without using any glue**, then slightly modify or *custom fit* the part as necessary for the best fit.
- Whenever the term **glue** is written you should rely upon your experience to decide what type of glue to use. When a specific type of adhesive works best for that step, the instructions will make a recommendation.
- Whenever just **epoxy** is specified you may use **either** 30-minute (or 45-minute) epoxy **or** 6-minute epoxy. When 30-minute epoxy is specified it is **highly** recommended that you use only 30-minute (or 45-minute) epoxy, because you will need the working time and/or the additional strength.
- **Photos** and **sketches** are placed **before** the step they refer to. Frequently you can study photos in following steps to get another view of the same parts.
- The Great Planes 1/3-scale Matt Chapman CAP 580 ARF is factory-covered with Top Flite MonoKote film. Should repairs ever be required, MonoKote can be patched with additional MonoKote purchased separately. MonoKote is packaged in six-foot rolls, but some hobby shops also sell it by the foot. If only a small piece of MonoKote is needed

for a minor patch, perhaps a fellow modeler would give you some. MonoKote is applied with a model airplane covering iron, but in an emergency a regular iron could be used. A roll of MonoKote includes full instructions for application. Following are the colors used on this model and order numbers for six foot rolls.

|               |          |
|---------------|----------|
| Red           | TOPQ0201 |
| Cub Yellow    | TOPQ0220 |
| Orange        | TOPQ0202 |
| Green         | TOPQ0214 |
| Black         | TOPQ0208 |
| Purple        | TOPQ0225 |
| Blue          | TOPQ0206 |
| Sapphire Blue | TOPQ0227 |
| White         | TOPQ0204 |

- The stabilizer and wing incidences and engine thrust angles have been factory-built into this model. However, some technically-minded modelers may wish to check these measurements anyway. To view this information, visit the web site at [www.greatplanes.com](http://www.greatplanes.com) and click on "Technical Data." Due to manufacturing tolerances that will have little or no effect on the way your model will fly, please expect slight deviations between your model and the published values.

## COMMON ABBREVIATIONS

|                              |
|------------------------------|
| Fuse = Fuselage              |
| Stab = Horizontal Stabilizer |
| Fin = Vertical Fin           |
| LE = Leading Edge            |
| TE = Trailing Edge           |
| LG = Landing Gear            |
| Ply = Plywood                |
| " = Inches                   |
| mm = Millimeters             |
| SHCS = Socket Head Cap Screw |

## KIT INSPECTION

Before starting to build, take an inventory of this kit to make sure it is complete and inspect the parts to make sure they are of acceptable quality. If any parts are missing or are not of acceptable quality, or if you need assistance with assembly, contact **Product Support**. When reporting defective or missing parts, use the part names exactly as they are written in the Kit Contents list.

**Great Planes Product Support:**  
3002 N Apollo Drive, Suite 1  
Champaign, IL 61822  
Telephone: (217) 398-8970, ext. 5  
Fax: (217) 398-7721  
E-mail: [airsupport@greatplanes.com](mailto:airsupport@greatplanes.com)

## KIT CONTENTS

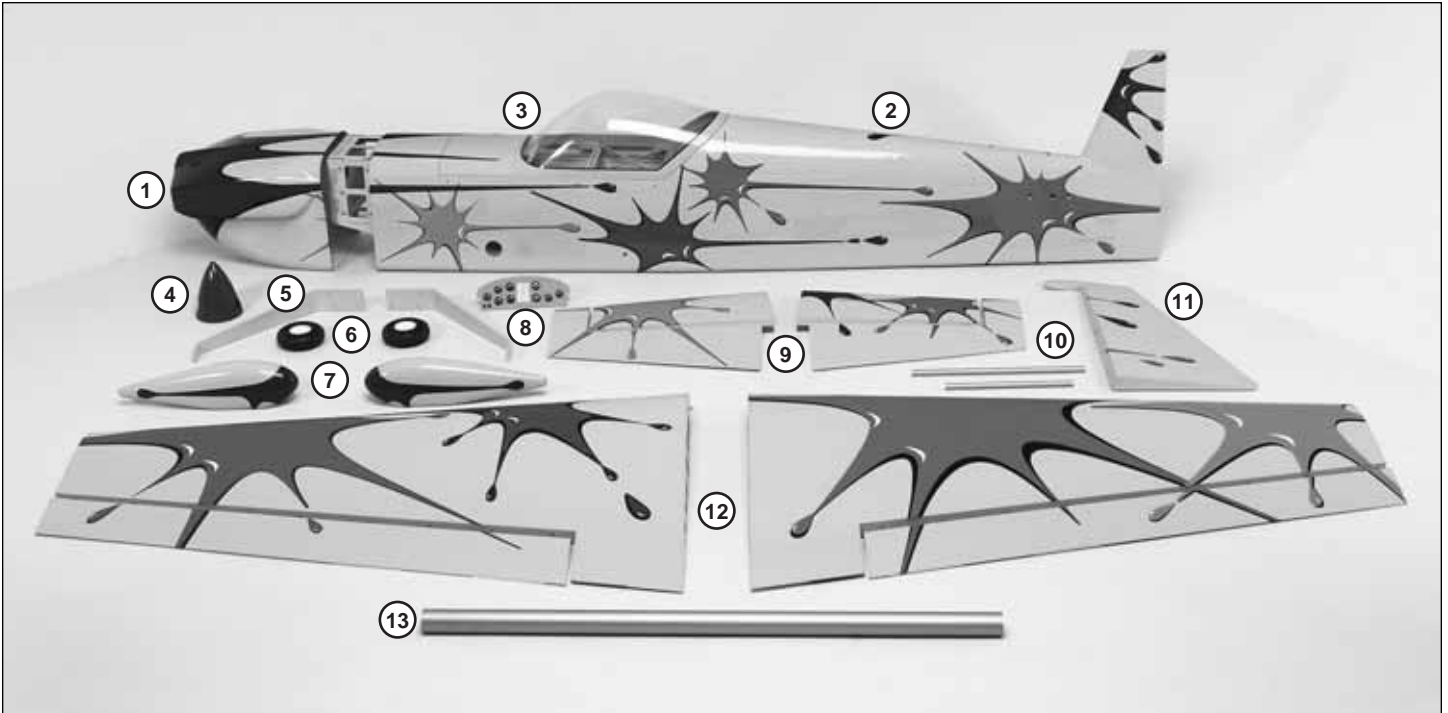

### Kit Contents (Photographed)

- |  |   |
|--|---|
| <ul style="list-style-type: none"> <li>1 Cowl</li> <li>2 Fuselage</li> <li>3 Canopy/Hatch</li> <li>4 Aluminum Spinner</li> <li>5 Main Gear</li> <li>6 Wheels</li> <li>7 Wheel Pants</li> </ul> | <ul style="list-style-type: none"> <li>8 Instrument Panel</li> <li>9 Stab and Elevators</li> <li>10 Stab Tubes</li> <li>11 Rudder</li> <li>12 Wings and Ailerons</li> <li>13 Wing Tube</li> </ul> |
|--|---|

### Kit Contents (Not Photographed)

- |   |  |
|---|--|
| <ul style="list-style-type: none"> <li>Brass Quick Connect Body (2)</li> <li>4-40 Threaded Steel Cevis (4)</li> <li>Axles (2)</li> <li>4-40 Blind Nut (8)</li> <li>8-32 Blind Nut (18)</li> <li>Nuts for Axles (2)</li> <li>1/4-20 Blind Nuts (6)</li> <li>4-40 Lock Nut (8)</li> <li>Nylon Clevis (1)</li> <li>Nylon Retainer (2)</li> <li>36" Flexible Pushrod Tube (2)</li> <li>36" Inner Flexible Pushrod Tube (2)</li> <li>Retainers (5)</li> <li>6/32 x 1/4" Socket Head Cap Screws (4)</li> <li>#4 x 5/8" Wood Screw (8)</li> <li>4-40 Set Screw (2)</li> <li>8-32 x 3/4" Socket Head Cap Screws (18)</li> <li>4-40 x 1/2" Socket Head Cap Screws (8)</li> <li>4-40 x 3/4" Socket Head Cap Screws (2)</li> <li>1/4" Flat Washers (4)</li> <li>3/16" Wheel Collars (4)</li> <li>2-56 x 4" Wire Threaded One End (4)</li> <li>4-40 x 12" Fully Threaded Rod (1)</li> </ul> | <ul style="list-style-type: none"> <li>#4 Lock Washer (14)</li> <li>#4 Flat Washer (14)</li> <li>#8 Lock Washer (18)</li> <li>#8 Flat Washer (18)</li> <li>1-1/2" Tailwheel (1)</li> <li>1/4" x 2-1/2" Hex Bolt (4)</li> <li>1/4" Lock Washer (4)</li> <li>Antirotation Dowels for the Wing (4)</li> <li>Engine Spacers, 6mm Thick, Aluminum (20)</li> <li>Fuel Tank (1)</li> <li>Pilot (1)</li> <li>Pin Hinges (33)</li> <li>Servo Tray (1)</li> <li>Stab Tube Aft (1)</li> <li>Stab Tube Front (1)</li> <li>Decal Sheet (2)</li> <li>Tail Gear Assembly (1)</li> <li>Ball Link Set (8)</li> <li>Control Horn Set (8)</li> <li>Pushrods 2-1/2" (6)</li> <li>Pushrods 4-1/2" (2)</li> <li>Servo Arm Set (1)</li> </ul> |
|---|--|

## ORDERING REPLACEMENT PARTS

Replacement parts for the Great Planes 1/3-scale Matt Chapman CAP 580 ARF are available using the order numbers in the **Replacement Parts List** that follows. The fastest, most economical service can be provided by your hobby dealer or mail-order company.

To locate a hobby dealer, visit the Great Planes web site at [www.greatplanes.com](http://www.greatplanes.com). Choose "Where to Buy" from the menu on the left side of the page. Follow the instructions provided on the page to locate a U.S., Canadian or International dealer. If a hobby shop is not available, replacement parts may also be ordered from Tower Hobbies at [www.towerhobbies.com](http://www.towerhobbies.com), or by calling toll free (800) 637-6050.

Parts may also be ordered directly from Hobby Services by calling (217) 398-0007, or via facsimile at (217) 398-7721, but full retail prices and shipping and handling charges will apply. Illinois and Nevada residents will also be charged sales tax. If ordering via fax, include a Visa® or MasterCard® number and expiration date for payment.

Mail parts orders and payments by personal check to:

Hobby Services  
3002 N Apollo Drive, Suite 1  
Champaign IL 61822

Be certain to specify the order number exactly as listed in the **Replacement Parts List**. Payment by credit card or personal check only; no C.O.D.

If additional assistance is required for any reason contact Product Support by e-mail at [productsupport@greatplanes.com](mailto:productsupport@greatplanes.com), or by telephone at (217) 398-8970.

### Replacement Parts List

| <u>Order Number</u> | <u>Description</u>                 | <u>How to Purchase</u>  |
|---------------------|------------------------------------|-------------------------|
|                     | Missing pieces .....               | Contact Product Support |
|                     | Instruction manual.....            | Contact Product Support |
|                     | Full-size plans .....              | Not available           |
|                     | Kit parts listed below.....        | Hobby Supplier          |
|                     |                                    |                         |
| GPMA2650.....       | Wing Set                           |                         |
| GPMA2651.....       | Fuselage                           |                         |
| GPMA2652.....       | Stabilizer/Elevator Set            |                         |
| GPMA2653.....       | Stabilizer Joiner Tubes            |                         |
| GPMA2654.....       | Rudder                             |                         |
| GPMA2655.....       | Wing Joiner Tube                   |                         |
| GPMA2656.....       | Cowl                               |                         |
| GPMA2657.....       | Hatch/Canopy                       |                         |
| GPMA2658.....       | Landing Gear                       |                         |
| GPMA2659.....       | Wheel Pants                        |                         |
| GPMA2660.....       | Spinner                            |                         |
| GPMA2661.....       | Instrument Panel                   |                         |
| GPMA2662.....       | Tailwheel Assembly (without wheel) |                         |
| GPMA2663.....       | Decal Set                          |                         |

## ASSEMBLE THE STAB

### Attach the Elevators

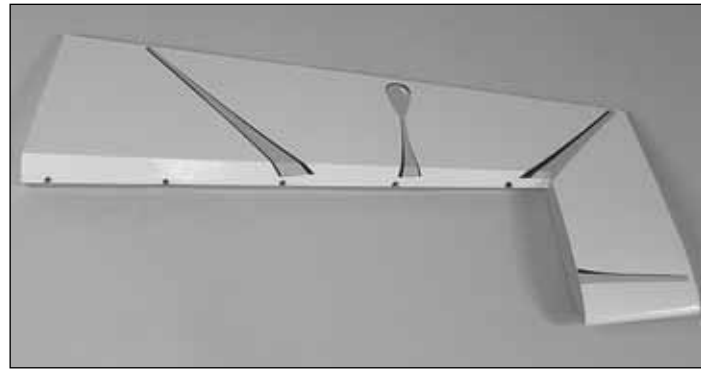
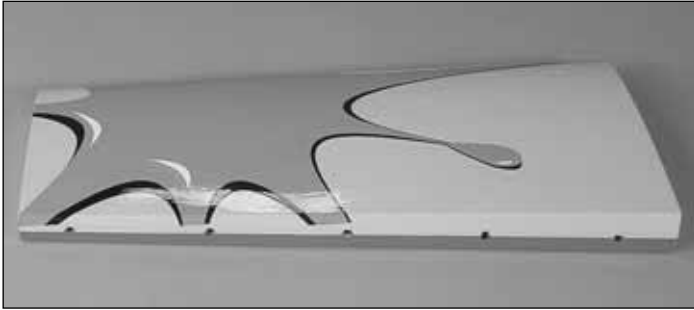

□ □ 1. Cut the covering from the five holes for the hinge points in the trailing edge of one of the stab halves and the leading edge of the elevator.

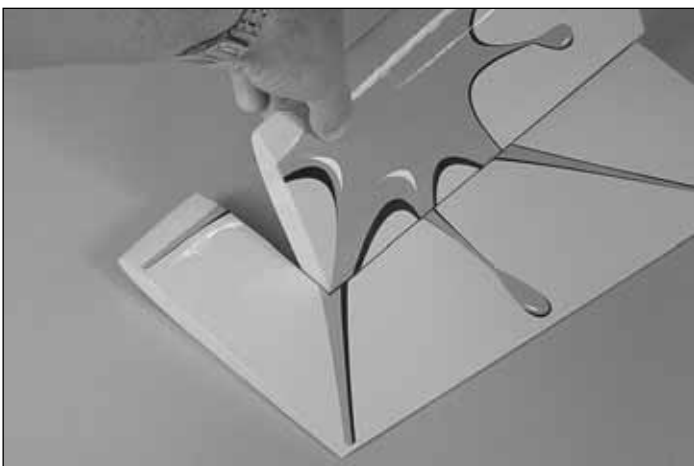
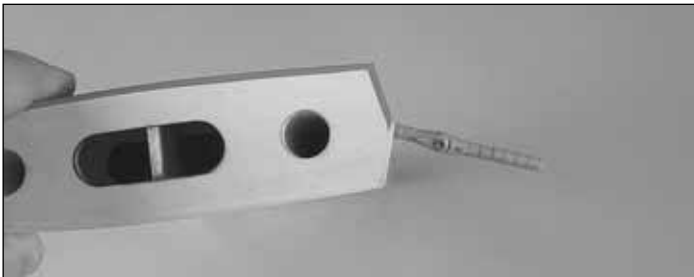

□ □ 2. Temporarily attach the elevator to the stab with five hinges. Note the inner hinges go in at an angle to clear the stab tube. Check that there is free movement of the elevator through all of its throw. Remove the hinges.

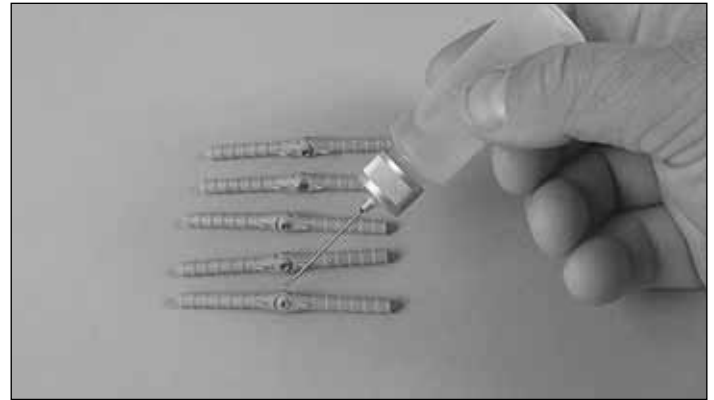

□ □ 3. Place a drop of oil on the pivot point of each of the hinges.

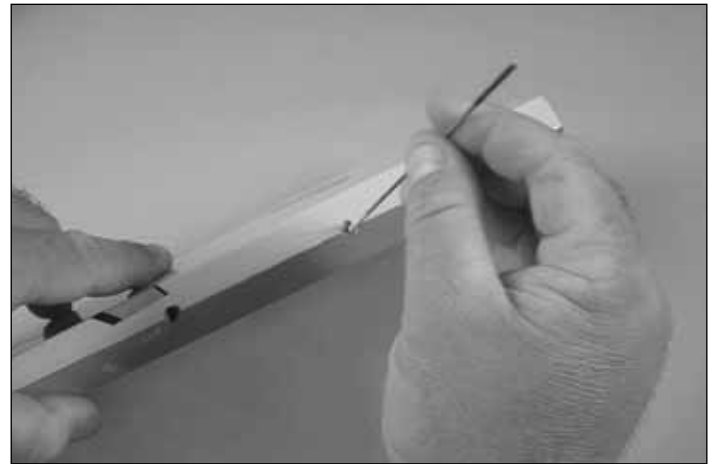

□ □ 4. Mix up some 30-minute epoxy and microballoons (if using mixing cups, approximately 1/4 oz. of microballoons added to 1/8 oz. of mixed epoxy is recommended). Use a piece of music wire to **thoroughly** apply the mixture in the holes in the stab and elevator. Use the wire to get the epoxy out of the outer edge of the opening of the holes in the elevator so it doesn't get into the hinge pins. Wipe away any epoxy around the outside of the holes with a paper towel.

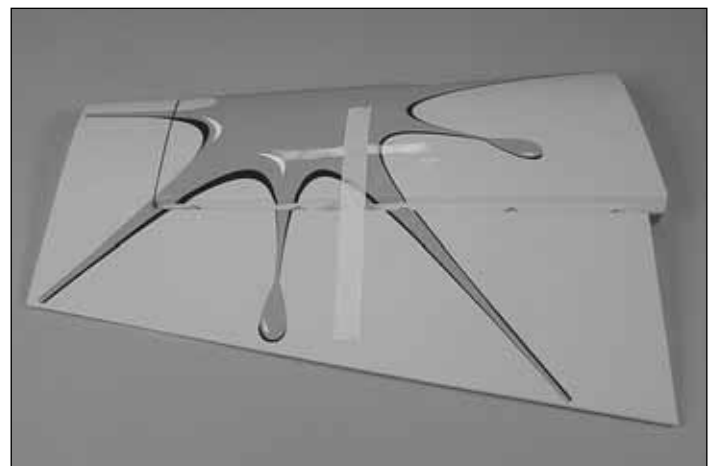

□ □ 5. Fit the hinges in the stab and elevator. Tape the stab to the elevator and set aside until the epoxy has cured.

□ □ 6. Repeat steps 1 through 5 for the other stab half.



## Prepare the Servo Arms

**Note:** The included aluminum servo arms are designed with plastic inserts, allowing the arms to work with all current Futaba, Hitec, Airtronics and JR servos. The inserts are also designed so that the centering of the arm can be adjusted by rotating the insert and then re-attaching the arm.



1. Drill and tap 4-40 threads in the two outermost holes of each of the six single-sided servo arms.

2. Drill and tap 4-40 threads in the outer hole of the 4-1/4" [106mm] servo arm.

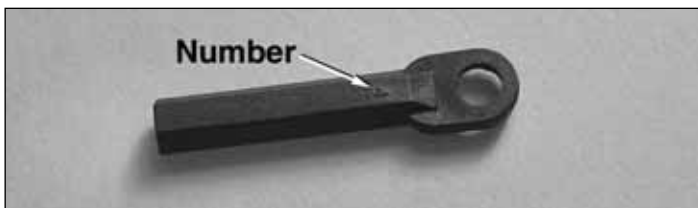

3. The nylon ball links have a number on one side of them. With the number facing up, press the brass ball into each of the nylon balls link from the bottom, opposite the number.



4. Attach the ball link to the inner tapped hole of one of the one-sided servo arms with 4-40 x 1/2" [13mm] Socket

Head Cap Screw [SHCS] brass stand off and 4-40 lock nut.  
**Note:** The number goes toward the servo arm.

5. Attach the ball links to the five other single-sided servo arms.

## Mount the Elevator Servos

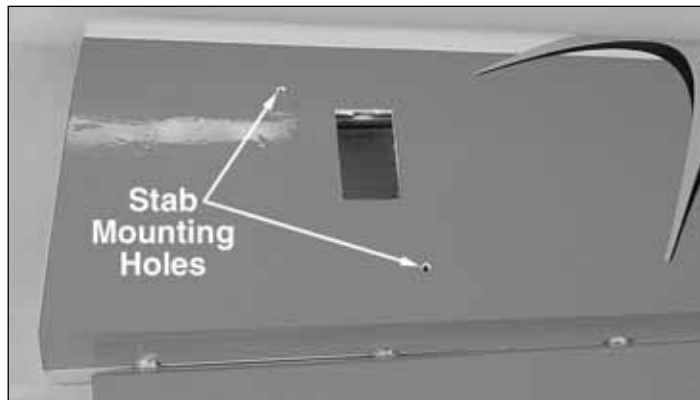

1. Trim the covering from the servo opening and stab mounting holes in the bottom of one stab.



2. Mount the elevator servo to that stab half, using the hardware provided with your servos, remembering to harden the threads with thin CA.

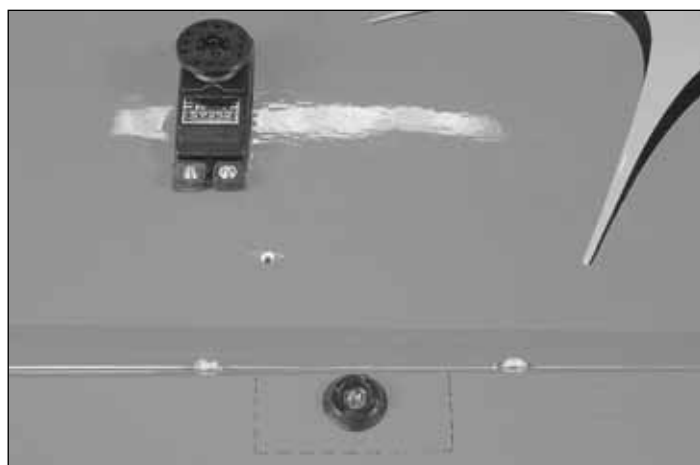

3. Center the nylon pivot washer on the plywood support and align it with the leading edge of the elevator.

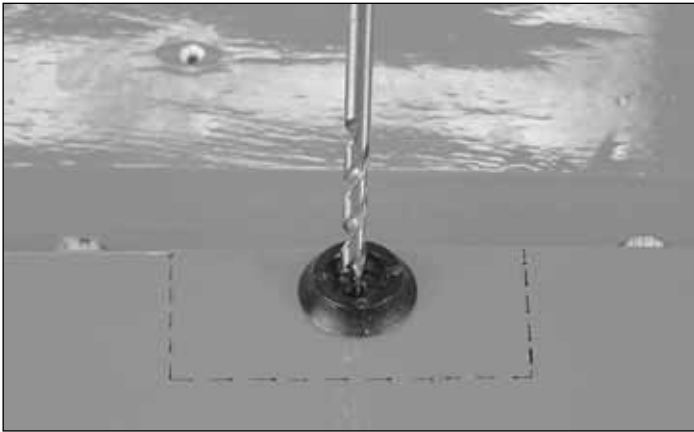

4. Drill a 9/64" [3.6 mm] hole through the elevator centered on the pivot washer.

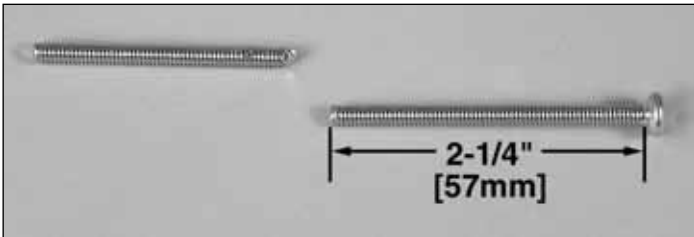

5. Cut the 4" [100mm] control horn bolt to a length of 2-1/4" [57mm].

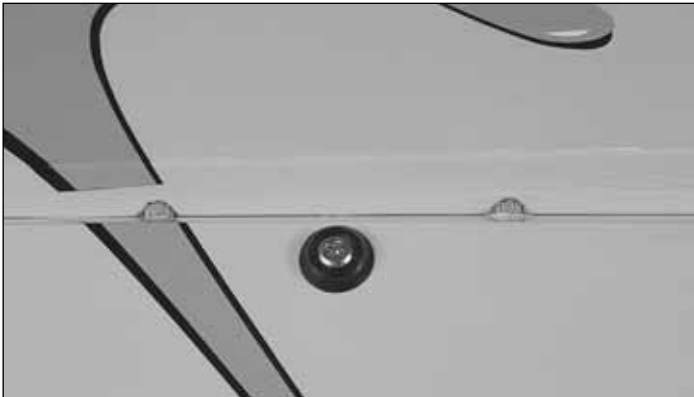

6. Place a pivot washer on the control horn bolt. Screw the control horn bolt through the top of the elevator.



7. Screw the nylon nut and pivot washer onto the control horn bolt.

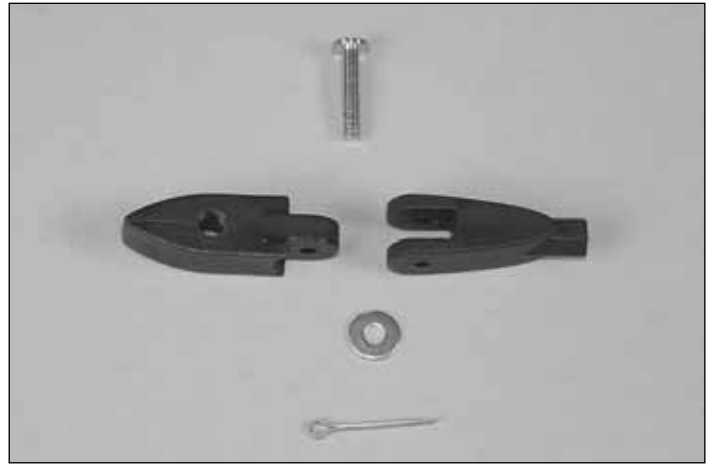

8. Assemble the control horn parts as shown.



9. Screw the **reverse** threaded end of the 2-1/2" [65mm] pushrod 15 full turns into the control horn. (To tighten, turn counterclockwise.)

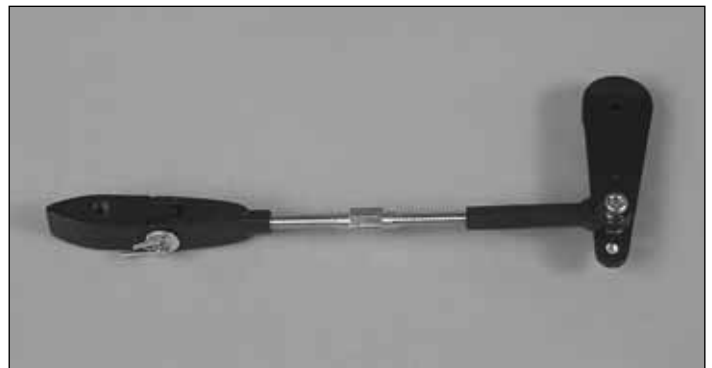

10. Screw the "normal" threaded end of the pushrod 15 turns into the ball link that is connected to one of the single-sided servo arms.

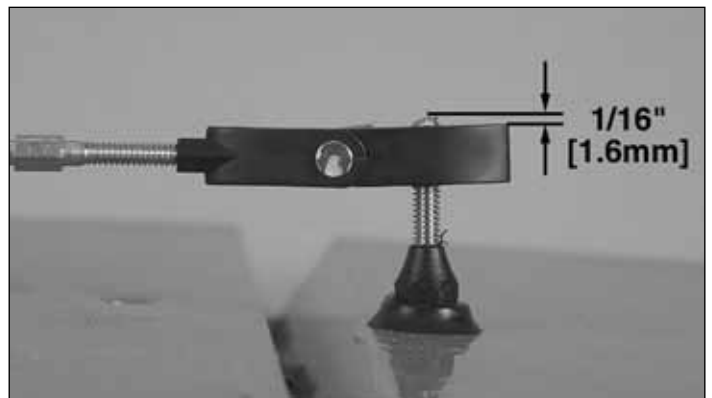

11. Screw the control horn onto the control horn bolt, leaving 1/16" [1.6mm] extending from the top of the control horn.

❑ ❑ 12. Remove the stock servo arm from the servo. Plug the servo into the receiver and turn the radio on.

❑ ❑ 13. Place the appropriate servo arm insert on the servo. The inserts have letters stamped on the bottom of them (A=Airtronics/JR, F=Futaba, H=Hitec).

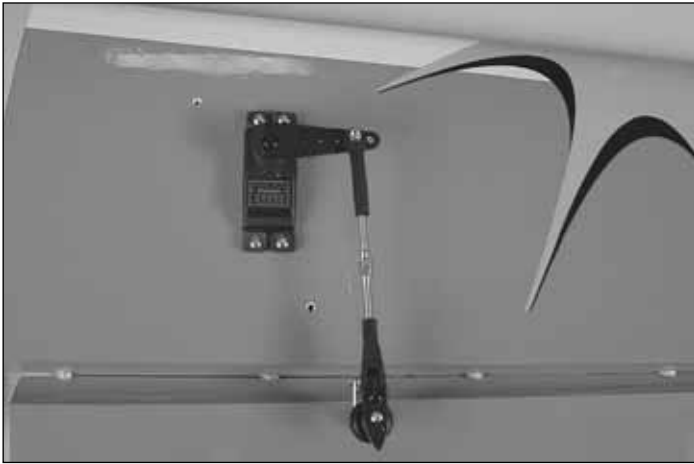

❑ ❑ 14. Attach the aluminum servo arm to the servo so that it is 90 degrees to the long side of the servo case. If it is not, remove the servo arm, rotate the insert 90 degrees and attach the servo arm again. Use the insert position that makes the servo arm fit closest to 90 degrees. Be sure to secure the servo arm with the screw.

❑ ❑ 15. Adjust the pushrod by turning it until the elevator is centered on the stab.

❑ 16. Repeat steps 1-15 for the other stab half.

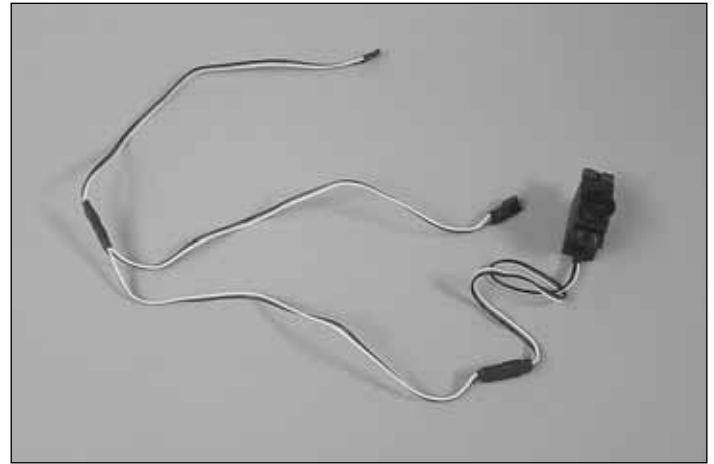

❑ ❑ 3. Secure one aileron servo lead to a long Y-harness with string or a piece of heat shrink tubing (not included). Hobbico Heavy Duty Y-Harnesses (HCAM2751) were used on our models.

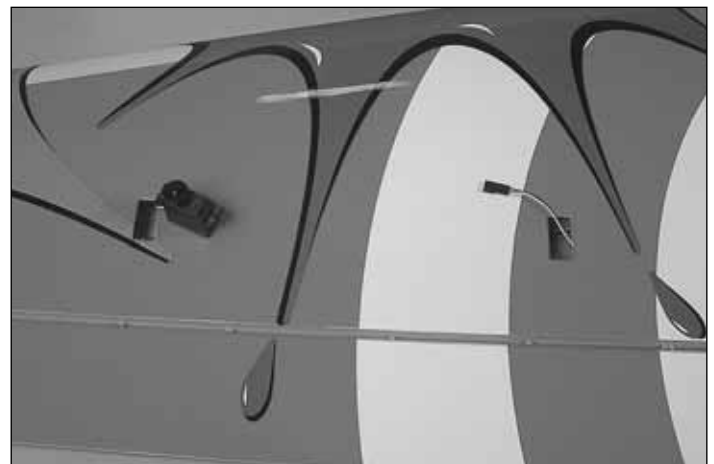

## ASSEMBLE THE WING

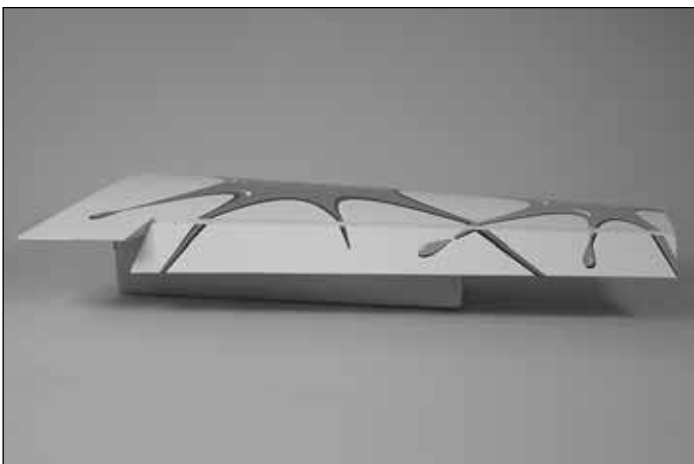

❑ ❑ 1. Repeat the hinging process used on the stab to attach one aileron to its wing.

❑ ❑ 2. Remove the covering from the servo openings in the bottom of the wing.

❑ ❑ 4. Use the string in the wing to pull the y-harness through the wing from the outer servo opening. Pull the second end of the y-harness out of the inner servo opening. Secure the second servo lead to the Y-harness just as you did with the first one. Mount the servos, noting that the servo arms go toward the trailing edge of the wing.

## ASSEMBLE THE FUSE

### Install the Tail Gear

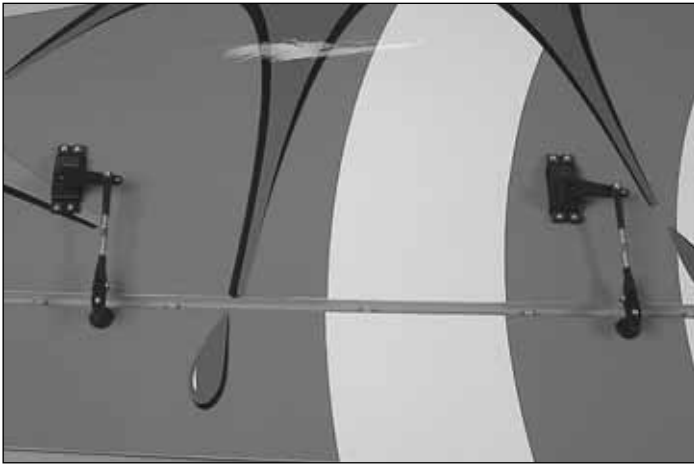

□ □ 5. Mount the control horns and servo arms following the same steps used with the stab.

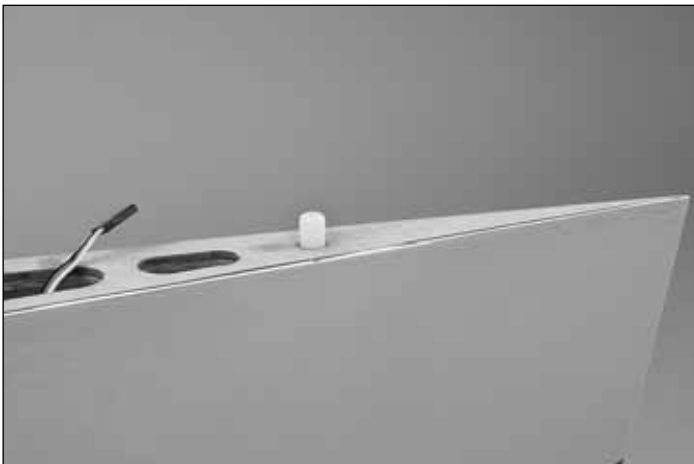

□ □ 6. Glue the white nylon anti-rotation dowels in the wing with epoxy.

□ 7. Repeat steps 1-6 for the other wing.



□ 1. Grind flat spots on the tail gear wire for the set screws. Assemble the tail gear as shown in the photo with threadlocker.

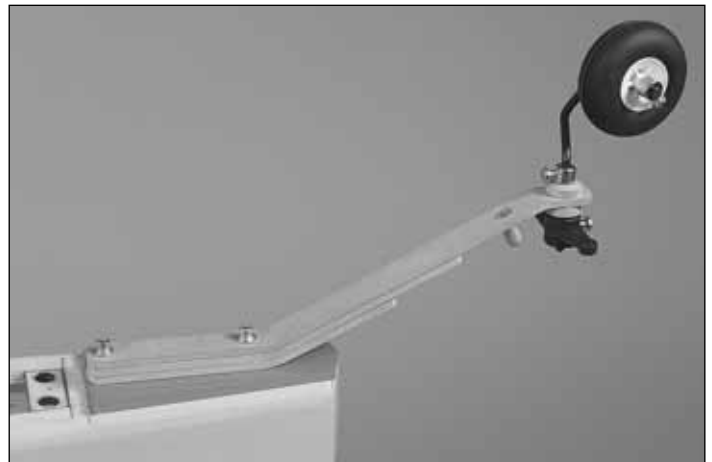

□ 2. Remove the covering for the tail gear mounting bolts. Attach the tail gear with threadlocker, 4-40 x 3/4" [19mm] SHCS, #4 flat washer and #4 lock washer.

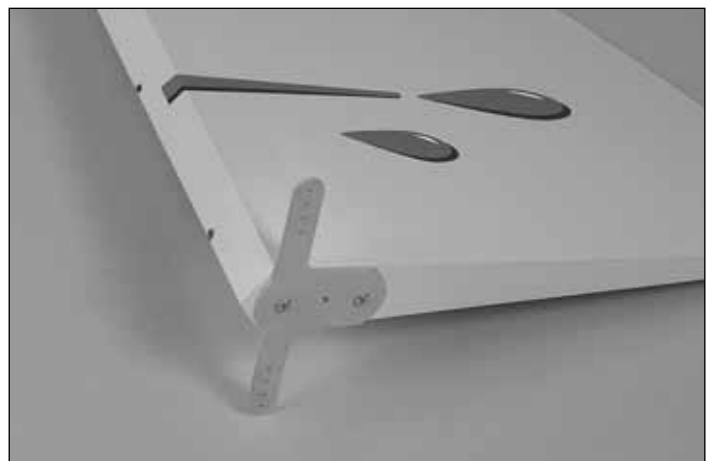

□ 3. Attach the tail gear steering arm to the bottom of the rudder with two #4 x 5/8" wood screws.

## Attach the Rudder



1. Mark the rudder 2-1/4" [57mm] from the bottom and 3/8" [9.5mm] from the LE. Drill a 9/64" [3.6mm] hole through the rudder. Be certain to drill perpendicular to the centerline of the rudder.

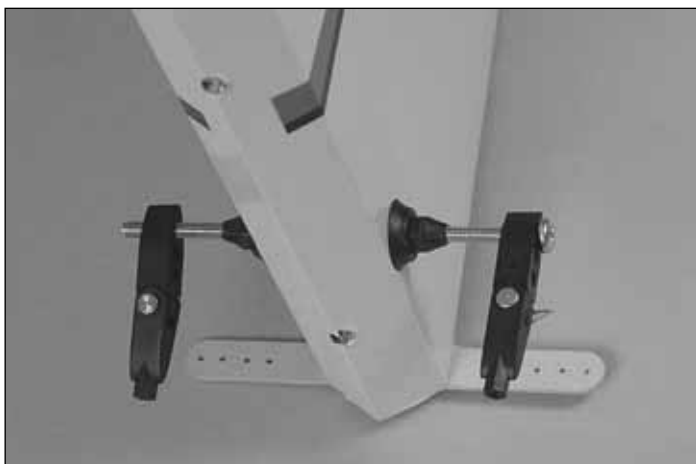

2. Mount the rudder control horns as shown, using the remaining uncut 4" bolt.
3. Hinge the rudder using the same procedure used on the stabs and wings. **Note:** don't forget to oil the pivot point of each hinge.

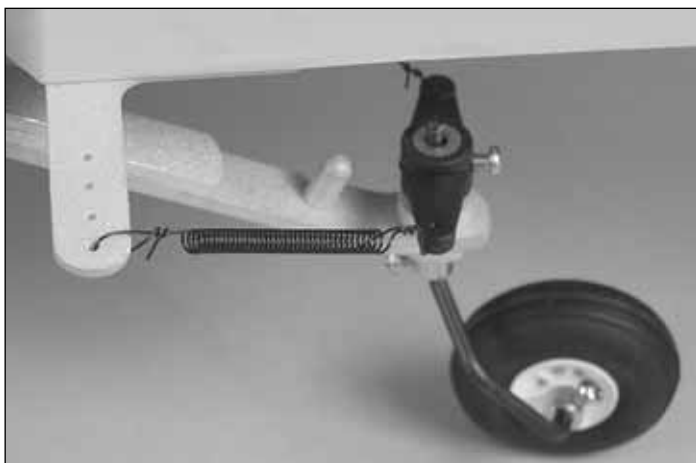

4. Attach the tail gear arm to the tail gear with the two springs.

## Install the Rudder Servo(s)

**RUDDER SERVO OPTIONS:** The large size of the rudder on the Giant CAP 580 requires a lot of servo torque. Our testing shows that less than 300 ounce inches of servo power results in rudder "blow back" during certain maneuvers. We have three recommendations to provide adequate performance:

- A. The instructions are written for two quarter-scale Futaba S5050 servos. This is the recommended setup.
- B. It is possible to use standard size high-torque servos ganged together. There are two servo openings on either side of the fuse for standard size servos. A 150+ oz/in standard size servo can be installed on either side of the fuse. Two 2" [50mm] servo arms will need to be purchased.
- C. Four standard size high torque servos (with a total of 300+ oz/in torque) can be used. This is the least recommended of the setups, and will require the modeler to modify the model to install the 4 servos.

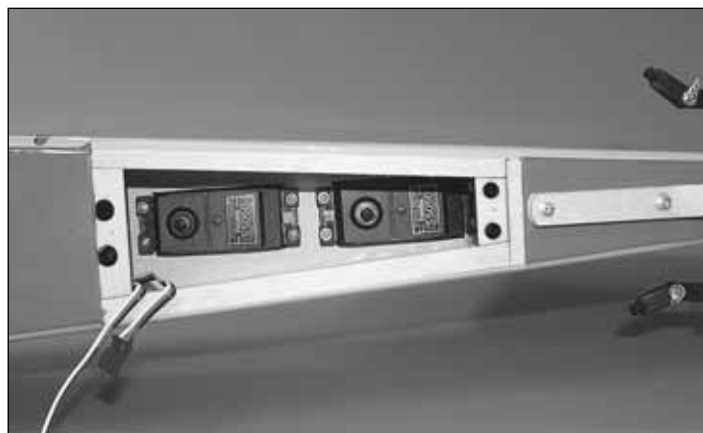

1. Install the two giant-scale servos with the hardware provided with the servos. (We used Futaba S5050 servos in our models.)

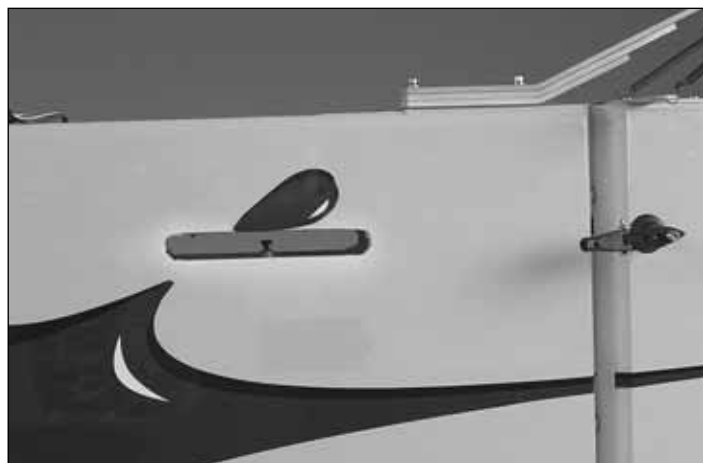

2. Remove the covering from the pushrod exits on both sides of the fuse.

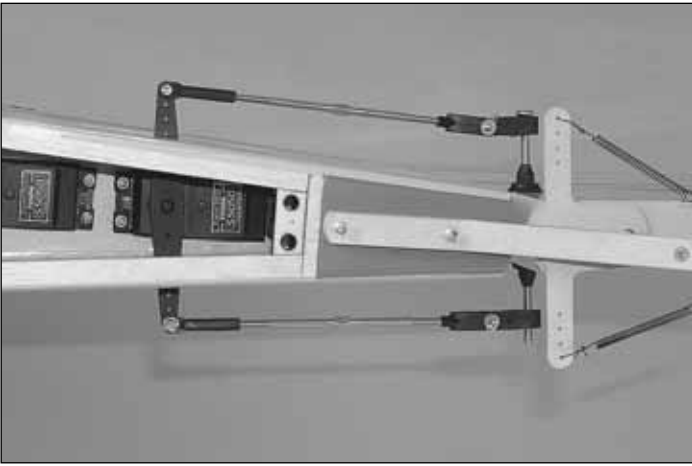

- ❑ 3. Install the rudder linkage and servo arm as shown.
- ❑ 4. Fit the included 2-1/4" [57mm] double-sided servo arm on the forward rudder servo.

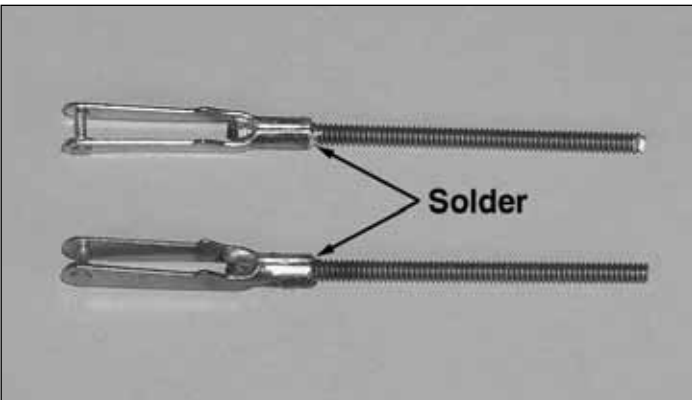

- ❑ 5. Cut two 2" [50mm] pieces from the 4-40 x 12" [305mm] threaded rod.
- ❑ 6. Solder a 4-40 metal clevis to one end of each of the 2" threaded rods.

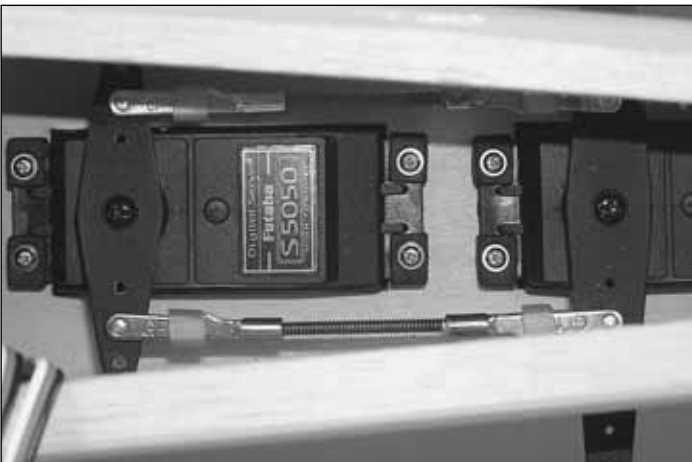

- ❑ 7. Install the 2" double-sided servo arm on the forward servo.
- ❑ 8. Install the pushrods. **Note:** If any binding occurs, slightly enlarge the holes in the servo arms. A small amount of free play is preferred with these 2 pushrods to avoid the 2 servos "fighting" one another.

## Install the Main Gear

- ❑ ❑ 1. Attach the axle to the main gear with the nylon lock nut.
- ❑ ❑ 2. Install a wheel collar with a 6-32 x 1/4" [6mm] SHCS, the wheel and the other wheel collar also with a 6-32 x 1/4" [6mm] SHCS.

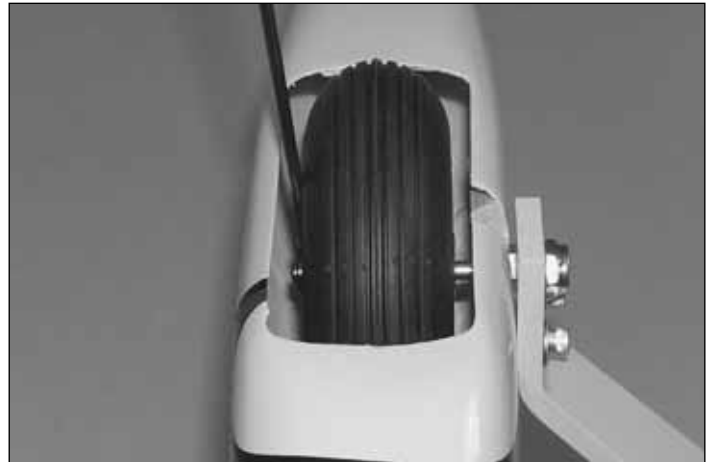

- ❑ 3. Mount the wheel pant with two 8-32 x 3/4" [19mm] SHCS. Center the wheel in the wheel pant and tighten the wheel collars.

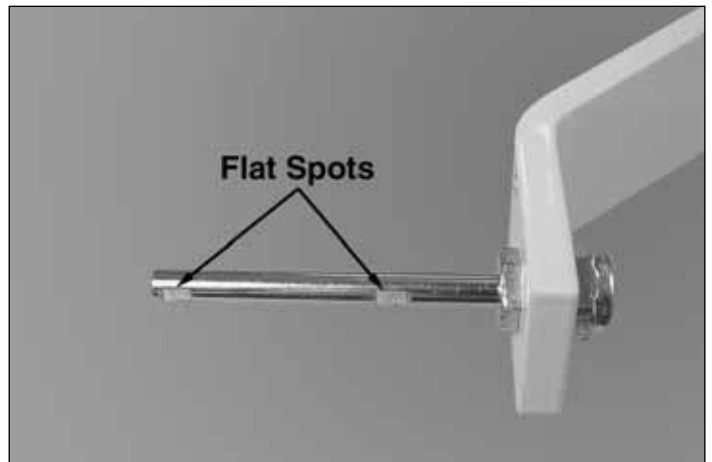

- ❑ ❑ 4. Remove the wheel pant. Mark the location of the wheel collars. File flat spots on the axles for SHCS that hold the wheel collars in place.
- ❑ ❑ 5. Mount the wheel with the wheel collars. Mount the wheel pant using threadlocker, two 8-32 x 3/4" [19mm] SHCS, two #8 flat washers and two #8 lock washers.



□ □ 6. Mount the landing gear to the fuse with threadlocker, four 8-32 x 3/4" [19mm] SHCS, four #8 flat washers and four #8 lock washers.

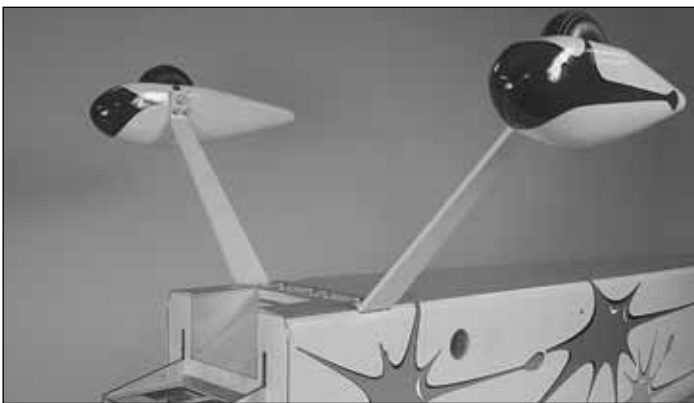

□ 7. Repeat steps 1 through 6 for the other landing gear leg.

### ***Mount the Engine***

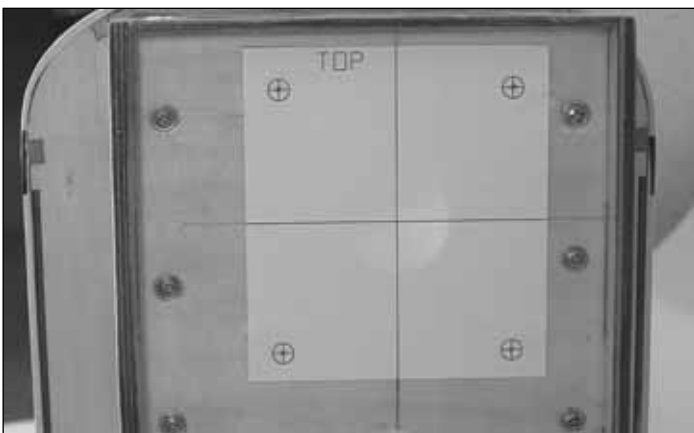

□ 1. If you are using a DA100, cut the engine mounting template from the rear of this manual. Align the printed lines with the lines on the firewall and tape the sketch in place. If you are using a different engine, use the template provided by the engine's manufacturer to center the engine on the embossed lines on the firewall.

□ 2. Drill 5/16" [8 mm] holes through the firewall at the locations indicated by the template.

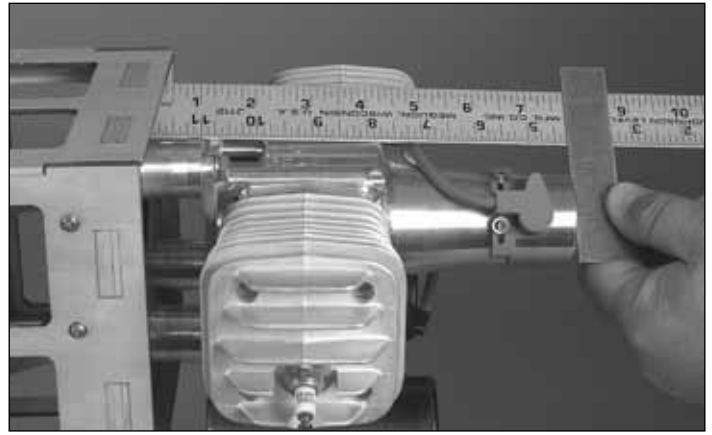

□ 3. Mount the engine to the firewall with 1/4-20 x 2-1/2" [64mm] bolts and the correct number of aluminum spacers required to make the total distance from firewall to the thrust washer at least 7-1/2" [190mm].

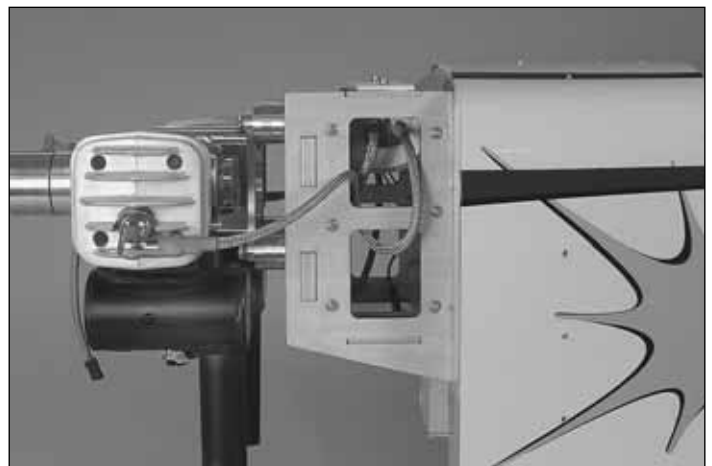

□ 4. After reading the caution provided immediately following this step, and remembering the importance of maintaining at least 12" [300mm] between anything engine/ignition related and anything radio related, follow the engine manufacturer's instructions to mount the ignition module. On our airplanes, we mounted it inside the top of the firewall box.

### ***Install the Throttle Servo***

**Because of the possibility of ignition engines creating radio noise, we use a plastic pushrod for the throttle servo installation. This isolates the engine and any radio noise from the servos. This is an IMPORTANT selection, and we cannot recommend strongly enough that you DO NOT change this pushrod to a metal pushrod. All radio equipment – including throttle servo, receiver battery, electronic kill switch, receiver on/off switch, servo leads – should be mounted at least 12" [300mm] away from anything related to the ignition/gasoline engine. Any material used between the engine and the radio equipment is STRONGLY recommended to be plastic, nylon, or otherwise non-metallic and non-conductive to minimize ignition noise transmission.**

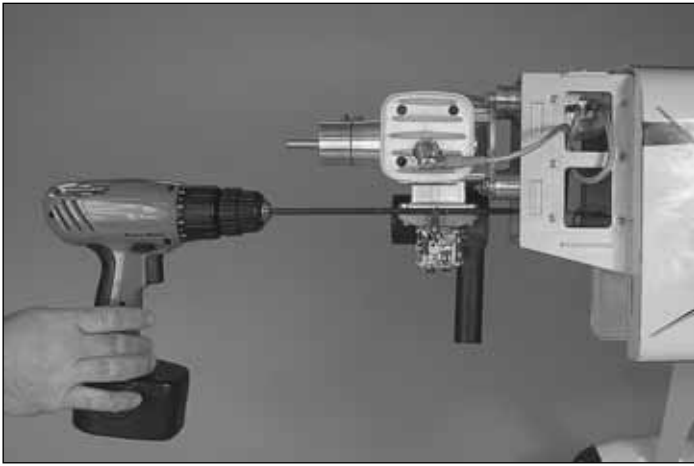

1. Drill a 3/16" [4.8mm] hole through the firewall and second former aligned with the throttle arm on engine.

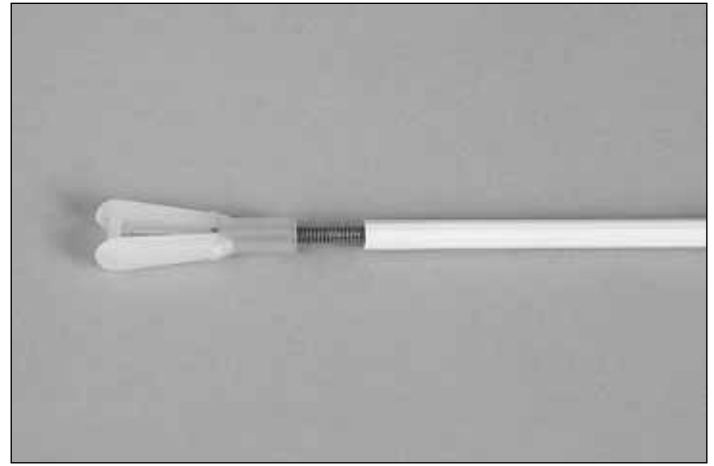

5. Cut a 1" [25mm] threaded section from one of the 2-56 x 4" [102mm] pushrods. Attach the nylon clevis to the white plastic pushrod using the threaded section.

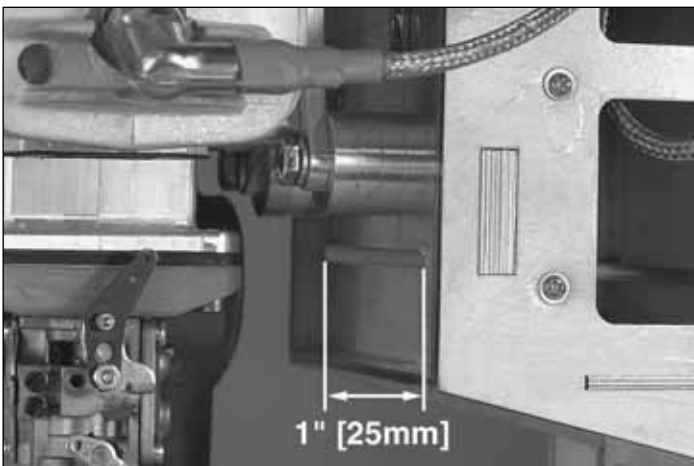

2. Glue a grey 3/16" x 36" [4.8 x 914mm] plastic pushrod tube to the holes in the firewall and second former, leaving approximately 1" [25mm] protruding from the front of the firewall.

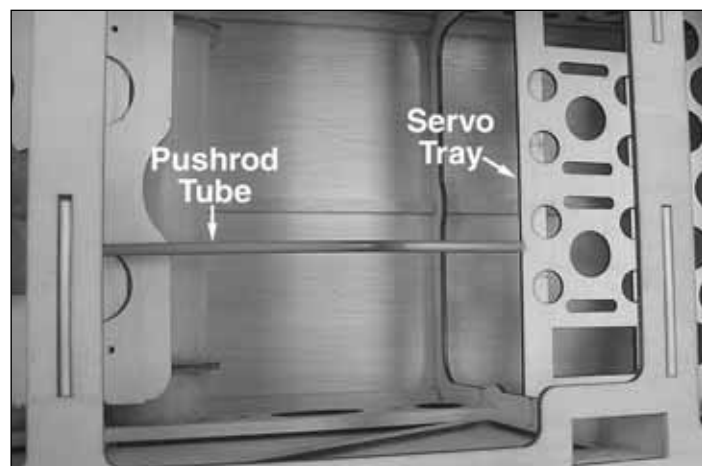
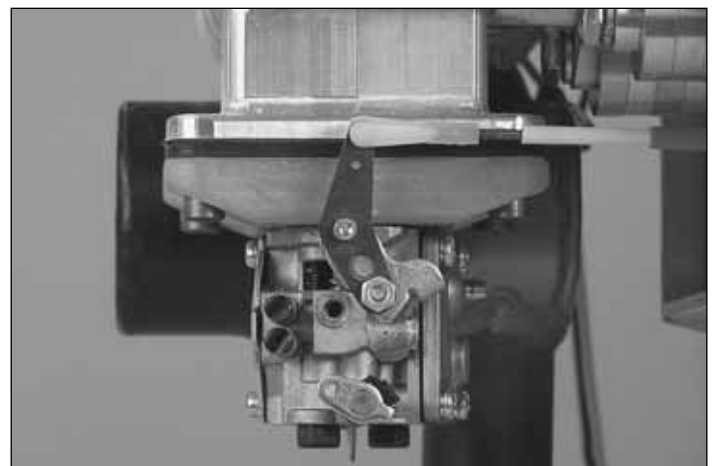

3. Cut the end of the pushrod tube even with the front of the servo tray.

4. Mount your throttle servo in the tray.

6. Slide the white plastic pushrod through the pushrod tube and attach the clevis to the throttle arm. Cut the other end flush with the servo end of the grey pushrod tube. Screw a 2-56 x 4" [102mm] pushrod into the white pushrod tube.



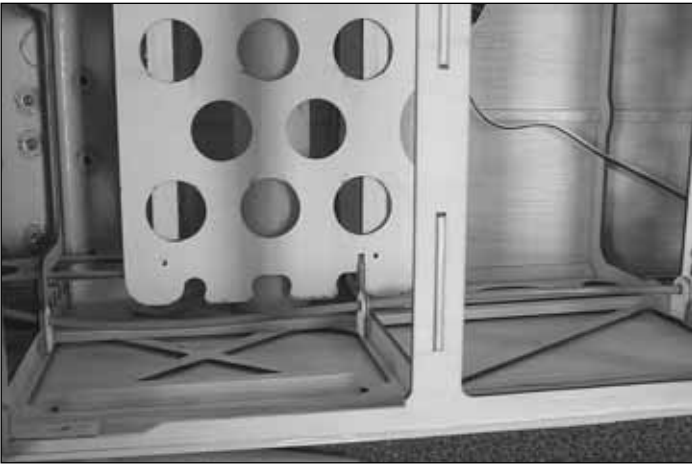

7. Slide three plywood pushrod supports over the grey pushrod tube. Attach the pushrod to the servo with the brass screw lock connector. Glue the supports to the formers and the pushrod tube.

### ***Install the Recommended Servo-Operated Kill Switch (Not Included)***

For safety, Great Planes recommends the installation of both a servo operated kill switch and a manual kill switch. A Great Planes kill switch (GPMG2150, not included) is used in all of our gasoline-powered aircraft.



1. Drill a 7/64" [2.8mm] hole through the end of the metal tab on the kill switch.



2. Drill a 3/16" [4.8mm] hole through the second former roughly in the location shown.

3. Install the grey pushrod outer tube in the fuse the same as was done with the throttle servo.

4. Screw a 2-56 x 4" [102mm] pushrod 10 turns into the white pushrod tube.

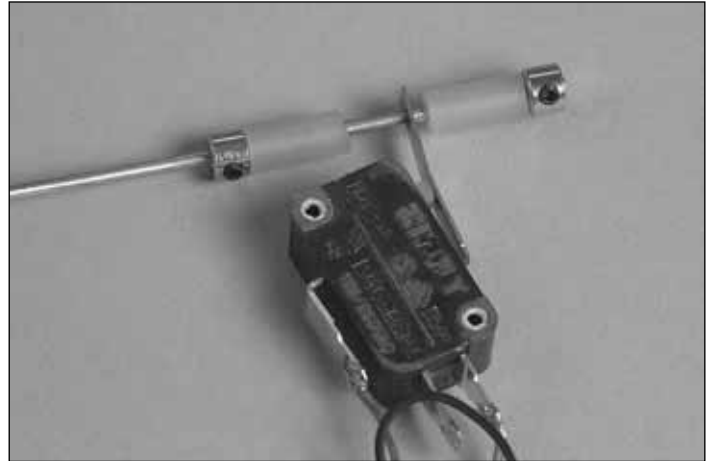

5. Attach the pushrod to the kill switch with two 3/32" [2.4mm] wheel collars and two 1/2" [13mm] pieces of fuel line.

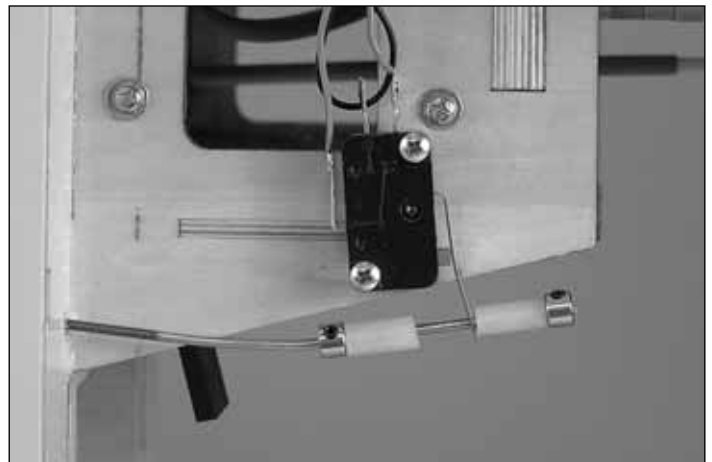

6. Mount the kill switch to the side of the firewall box with two #4 x 5/8" [16mm] screws so that the pushrod lines up with the hole in the kill switch.

7. Mount the kill switch servo. Connect the pushrod to the servo the same way the throttle servo was done.

8. Wire the servo operated kill switch and manually operated kill switch for your ignition.

## Assemble and Install the Fuel Tank



❑ 1. Assemble the stopper, brass tubes and steel stopper end plates as shown.

❑ 2. Solder the brass barbs to the ends of the brass tubes.  
**Note:** Get the tubes just hot enough for the solder to flow. If you get the tubes too hot it will damage the tank stopper.

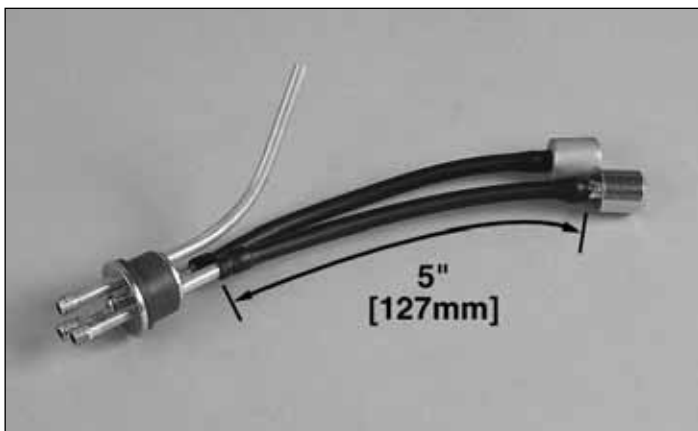

❑ 3. Attach the clunks to the short brass tubes with 5" [127mm] pieces of fuel line.

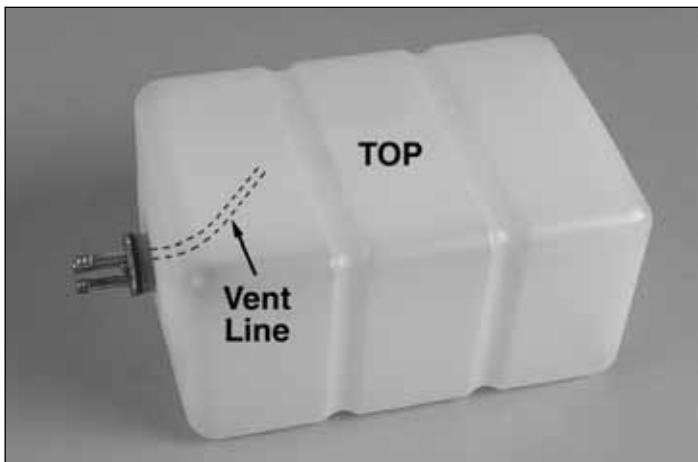

❑ 4. Install the stopper assembly in the tank with the vent line toward one of the longer sides of the tank. Mark that side of the tank as top.



❑ 5. Mount the tank to the tank tray with two #64 rubber bands.

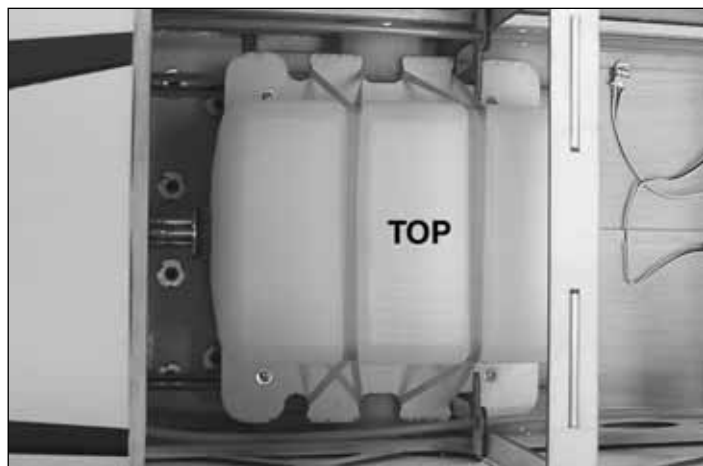

❑ 6. Mount the tank tray to the fuse with four #4 x 5/8" [15.9mm] screws and #4 flat washers.

❑ 7. Install the fuel lines. One clunk line goes to the carburetor; the other clunk line is for filling; the vent line gets routed out the bottom of the fuse.

## Mount the Cowl



❑ 1. Slide the cowl over the engine onto the fuselage. Use a Dremel tool with a cutting bit to trim the cowl where necessary

so you can get it to fit over the engine. If you are using the DA100, only a small hole for the front of the left muffler and slots for the muffler tubes need to be cut.



❑ 2. Cut a rectangle out of the bottom of the cowl that matches the air exit slot in the fuse.

❑ 3. Mount the spinner and position the cowl 1/8" [3.2mm] behind the spinner backplate.

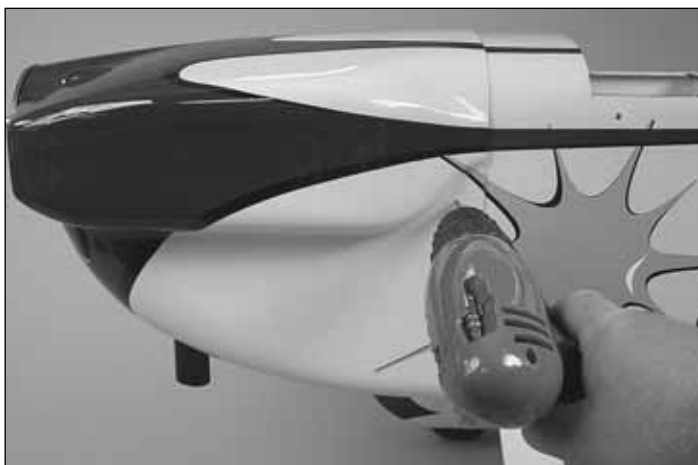

❑ 4. Drill a 9/64" [3.6mm] hole 3/4" [19mm] forward of the T.E. of the cowl and just below the cheek.

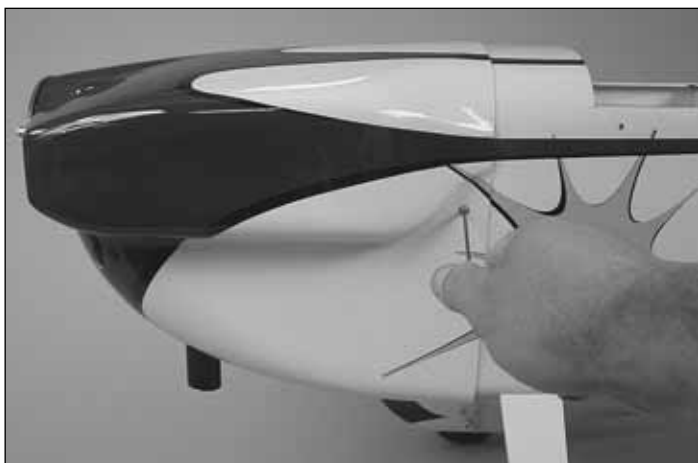

❑ 5. Attach the cowl at that point with a 4-40 x 1/2" [13mm] SHCS, #4 washer and 4-40 blind nut.

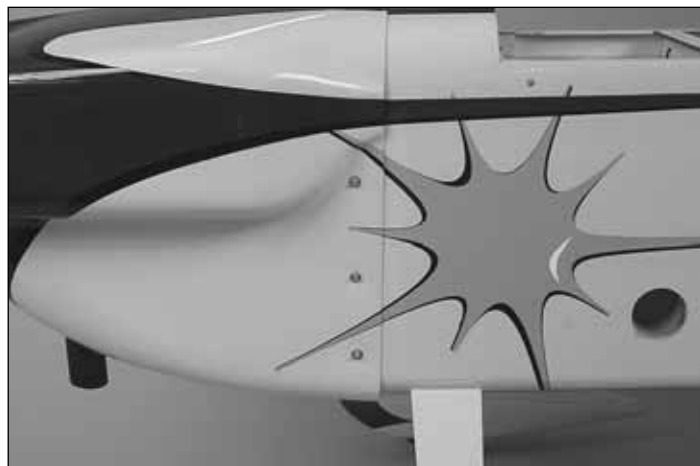

❑ 6. Working one at a time, repeat steps 4 and 5 to install 3 bolts on each side of the cowl.

## FINAL ASSEMBLY

### Mount the Stabilizers

The removable tail needs to be checked often for wear. If the tail develops excessive movement, thin CA sparingly applied to the inside of the stab tubes will cure it. If you are able to transport the CAP with the stabs installed, we recommend permanently attaching the stab to the fuse with epoxy.

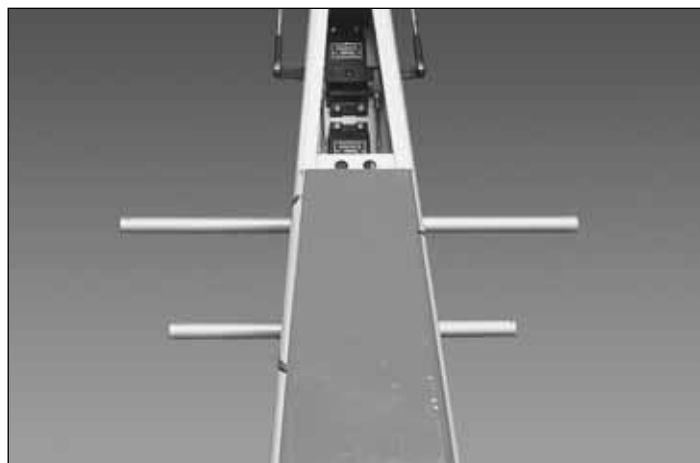

❑ 1. Slide the two aluminum stab tubes into the fuse.

❑ 2. Attach 36" [915mm] servo extensions to the elevator servos. If you are going to be permanently attaching the stabs, secure the servo leads with heat shrink tubing.

❑ 3. Stand the plane on its nose and feed the elevator servo wire down the fuse.

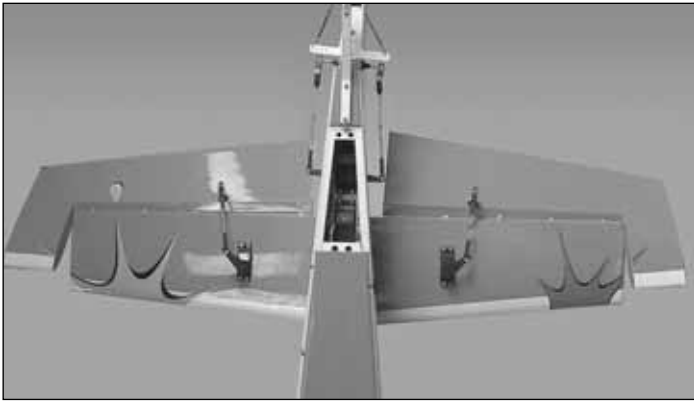

- 4. Slide the stabs onto the aluminum tubes with the stab root ribs tight on the fuse side.

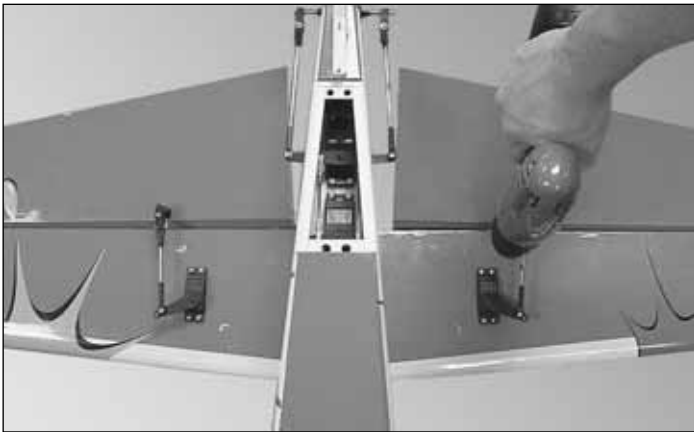

- 5. Drill a 1/16" [1.6mm] hole through the forward and aft stab tubes, using the holes in the bottom of the stab half as a guide. Be careful not to drill through the stab.
- 6. Attach the stab half to the tubes with two #4 x 5/8" [15.9mm] screws and two #4 washers.
- 7. Have an assistant hold the stab halves tight against the fuse. Drill the tubes for the second stab half.
- 8. Attach the second stab half to the tubes with two #4 x 5/8" screws and two #4 washers.
- 9. Attach 36" [915mm] servo extensions to the rudder servos. Route the extensions to the radio compartment.
- 10. Install the rudder servo hatch with two #4 x 5/8" [16mm] screws.

### ***Finish the Radio Installation***

- 1. Wrap your receiver and battery in 1/2" [13mm] foam. Mount your receiver and battery to the servo tray with the Velcro strips.
- 2. Plug in all of the servos, including the two 6" [150mm] extensions for the ailerons.
- 3. Mount the switch and charge jack.

### ***Check the C.G.***

**There are two wing locations on the plane. The reason for this is so that a range of engines can be used without the need for adding large amounts of weight to balance.**

- 1. First, determine which wing mounting location you will use. To do so, mount everything in the plane except the canopy and wing. Reach under the tank and lift the plane by the aft wing tube. If the plane is balanced, tail-heavy, or just slightly nose-heavy at this location, then this is where the wing will be mounted. If the plane is significantly nose-heavy, set it down and lift it by the forward wing tube. If the plane is more closely balanced, or still nose-heavy, using the forward tube, then this will be your wing location. If the plane is now tail-heavy using the forward wing tube to lift, use some weight strips to balance the plane in each location. Mount the wing in the position which requires the least weight.
- 2. Cut the covering from the wing tube locations you selected in step 1.
- 3. Slide the wing tube through the fuse.

### ***Mount the Wing***



- 1. Slide one wing onto the wing tube. Remove the covering from the appropriate holes in the fuselage for the wing dowels.



- 2. Attach the wing to the fuselage with the 1/4"20 x 2" [50mm] nylon bolt.
- 3. Attach the second wing to the fuselage.

## Attach the Canopy



- 1. Attach the pilot to the canopy frame with 6-minute epoxy.

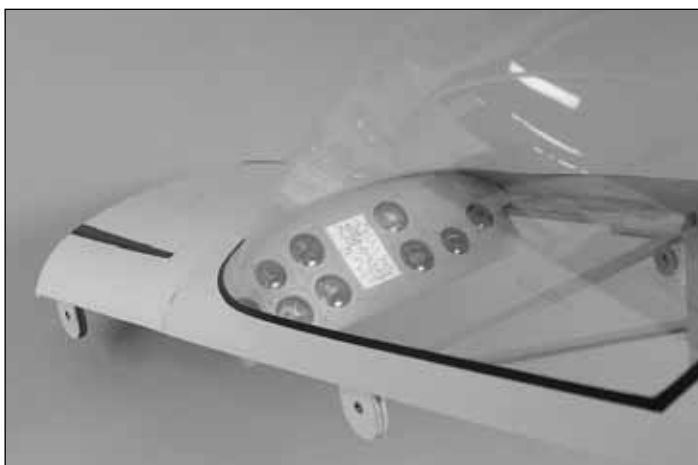

- 2. Attach the instrument panel to the canopy frame with medium CA.



- 3. Remove the covering from the six mounting holes for the canopy/hatch.

- 4. Mount the canopy to the fuselage with six 8/32 x 1" [25.4mm] SHCS, flat washers and lock washers.

## Apply the Decals

1. Use scissors or a sharp hobby knife to cut the decals from the sheet.

2. Be certain the model is clean and free from oily fingerprints and dust. Prepare a dishpan or small bucket with a mixture of liquid dish soap and warm water—about one teaspoon of soap per gallon of water. Submerge the decal in the soap and water and peel off the paper backing. **Note:** Even though the decals have a “sticky-back” and are not the water transfer type, submersing them in soap & water allows accurate positioning and reduces air bubbles underneath.

3. Position decal on the model where desired, using the picture on the box as a guide. Holding the decal down, use a paper towel to wipe most of the water away.

4. Use a piece of soft balsa or something similar to squeegee remaining water from under the decal. Apply the rest of the decals the same way.

## GET THE MODEL READY TO FLY

### Check the Control Directions

- 1. Turn on the transmitter and receiver and center the trims. If necessary, remove the servo arms from the servos and reposition them so they are centered. Reinstall the screws that hold on the servo arms.

- 2. With the transmitter and receiver still on, check all the control surfaces to see if they are centered. If necessary, adjust the clevises on the pushrods to center the control surfaces.

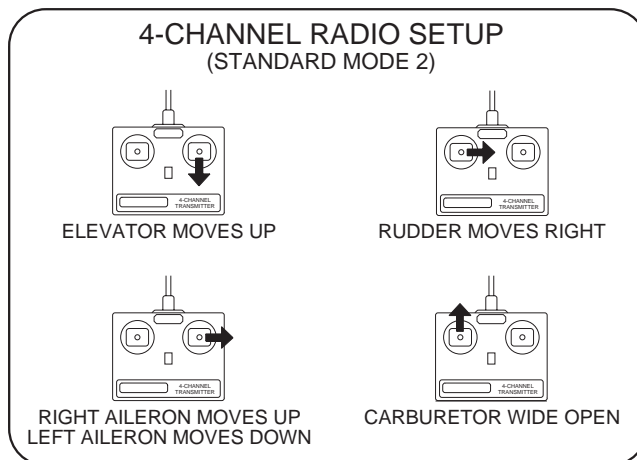

- 3. Make certain that the control surfaces and the carburetor respond in the correct direction as shown in the diagram. If any of the controls respond in the wrong direction, use the servo reversing in the transmitter to reverse the servos connected to those controls. Be certain the control surfaces have remained centered. Adjust if necessary.

## Set the Control Throws



Use a Great Planes AccuThrow™ (or a ruler) to accurately measure and set the control throw of each control surface as indicated in the chart that follows. **NOTE:** The throws are measured at the **widest part** of the elevators, rudder and ailerons.

### These are the recommended control surface throws:

|                  | High Rate                              | Low Rate                               |
|------------------|--|--|
| <b>ELEVATOR:</b> | 1-1/8" [28mm] up<br>1-1/8" [28mm] down | 7/8" [22mm] up<br>7/8" [22mm] down     |
| <b>RUDDER:</b>   | 3" [76mm] right<br>3" [76mm] left      | 2" [50mm] right<br>2" [50mm] left      |
| <b>AILERONS:</b> | 1-3/4" [44mm] up<br>1-3/4" [44mm] down | 1-3/8" [35mm] up<br>1-3/8" [35mm] down |

**For all out 3D: Set the throws as high as possible without binding.**

**IMPORTANT:** The Great Planes 1/3-scale Matt Chapman CAP 580 ARF has been professionally and **extensively** flown and tested to arrive at the throws at which it flies best. Flying your model at these throws will provide you with the greatest chance for successful first flights. If, after you have become accustomed to the way the Great Planes 1/3-scale Matt Chapman CAP 580 ARF flies, you would like to change the throws to suit your taste, that is fine. However, too much control throw could make the model difficult to control, so remember, "more is not always better."

## Balance the Model (C.G.)

More than any other factor, the **C.G.** (balance point) can have the **greatest** effect on how a model flies, and may determine whether or not your first flight will be successful. If you value this model and wish to enjoy it for many flights, **DO NOT OVERLOOK THIS IMPORTANT PROCEDURE.** A model that is not properly balanced will be unstable and possibly unflyable.

At this stage the model should be in ready-to-fly condition with all of the systems in place including the engine, landing gear, and the radio system.

**NOTE:** For a model this large, checking the CG requires two people.

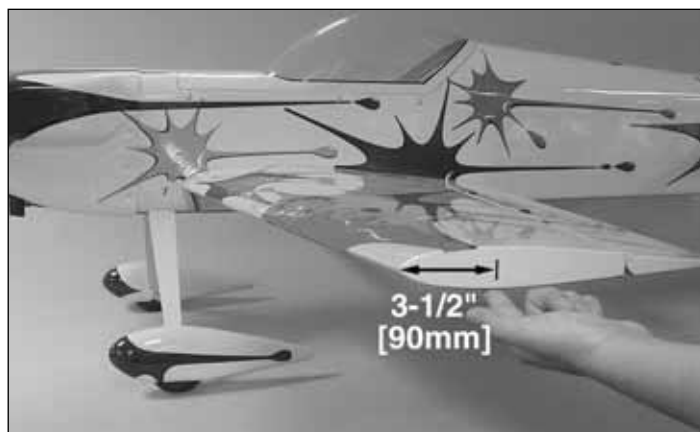

1. Using a felt-tip pen or 1/8" [3mm]-wide tape, accurately mark the C.G. on the tips of both wing panels. **The C.G. is located 3-1/2" [90mm] back from the leading edge of the wing AT THE WINGTIP, NOT THE FUSELAGE!**

This is where your model should balance for the first flights. Later, you may wish to experiment by shifting the C.G. up to 1/2" [13mm] forward or 1/2" [13mm] back to change the flying characteristics. Moving the C.G. forward may improve the smoothness and stability, but the model may then require more speed for takeoff and make it more difficult to slow for landing. Moving the C.G. aft makes the model more maneuverable, but could also cause it to become too difficult to control. In any case, **start at the recommended balance point** and do not at any time balance the model outside the specified range.

2. With the wing attached to the fuselage, all parts of the model installed (ready to fly) and an empty fuel tank, you and your helper lift the model from the marked CG location.

3. If the tail drops, the model is "tail heavy" and the battery pack and/or receiver must be shifted forward or weight must be added to the nose to balance. If the nose drops, the model is "nose heavy" and the battery pack and/or receiver must be shifted aft or weight must be added to the tail to balance.

❑ 4. If possible, relocate the battery pack and receiver to minimize or eliminate any additional ballast required. If additional weight is required, nose weight may be easily added by using Great Planes (GPMQ4485) “stick-on” lead. A good place to add stick-on nose weight is to the firewall or the engine box itself (don’t attach weight to the cowl—it is not intended to support weight). Begin by placing incrementally increasing amounts of weight on the engine box behind the engine until the model balances. Once you have determined the amount of weight required, it can be permanently attached. If required, tail weight may be added by temporarily removing the rudder servo hatch, installing the lead inside well clear of the servos, and reinstalling the hatch.

**Note:** Do not rely upon the adhesive on the back of the lead weight to permanently hold it in place. Over time, fuel and exhaust residue may soften the adhesive and cause the weight to fall off. Use #2 sheet metal screws, RTV silicone or epoxy to permanently hold the weight in place.

❑ 5. **IMPORTANT:** If you found it necessary to add any weight, recheck the C.G. after the weight has been installed.

### ***Balance the Model Laterally***

**NOTE:** Lateral balance is far more important to a precision aerobatic model than to the typical trainer, sport, or scale aircraft. As such, checking lateral balance is handled far more precisely for this type of aircraft. This process requires the assistance of 2 or ideally 3 people.

❑ 1. With the wing level, have an assistant help you lift the model by the engine propeller shaft and the bottom of the fuse via the tail gear.

❑ 2. Have your second assistant measure the distance each tip is above the floor.

❑ 3. Repeat the lift 3 or 4 times, checking the distance each time, and averaging the distances.

❑ 4. If one wing is more than 1/4" lower than the other on average, that side is heavy. Balance the airplane by adding weight to the other wing tip until it balances to within 1/4".

## ***PREFLIGHT***

### ***Identify Your Model***

No matter if you fly at an AMA sanctioned R/C club site or if you fly somewhere on your own, you should always have your name, address, telephone number and AMA number on or inside your model. It is **required** at all AMA R/C club flying sites and AMA sanctioned flying events.

### ***Charge the Batteries***

Follow the battery charging instructions that came with your radio control system to charge the batteries. You should always charge your transmitter and receiver batteries the night before you go flying, and at other times as recommended by the radio manufacturer.

**CAUTION:** Unless the instructions that came with your radio system state differently, the **initial** charge on **new** transmitter and receiver batteries should be done for 15 hours **using the slow-charger that came with the radio system**. This will “condition” the batteries so that the next charge may be done using the fast-charger of your choice. If the initial charge is done with a fast-charger the batteries may not reach their full capacity and you may be flying with batteries that are only partially charged.

### ***Balance Propellers***

Carefully balance your propeller and spare propellers before you fly. An unbalanced prop can be the single most significant cause of vibration that can damage your model. Not only will engine mounting screws and bolts loosen, possibly with disastrous effect, but vibration may also damage your radio receiver and battery. Vibration can also cause your fuel to foam, which will, in turn, cause your engine to run hot or quit.

### ***Ground Check***

**If the engine is new, follow the engine manufacturer’s instructions to break-in the engine.** After break-in, confirm that the engine idles reliably, transitions smoothly and rapidly to full power and maintains full power—indefinitely. After you run the engine on the model, inspect the model closely to make sure all screws remained tight, the hinges are secure, the prop is secure and all pushrods and connectors are secure.

### ***Range Check***

Ground check the operational range of your radio before the first flight of the day. With the transmitter antenna collapsed and the receiver and transmitter on, you should be able to walk at least 100 feet away from the model and still have control. Have an assistant stand by your model and, while you work the controls, tell you what the control surfaces are doing. Repeat this test **with the engine running** at various speeds with an assistant holding the model, using hand signals to show you what is happening. If the control surfaces do not respond correctly, **do not fly!** Find and correct the problem first. Look for loose servo connections or broken wires, corroded wires on old servo connectors, poor solder joints in your battery pack or a defective cell, or a damaged receiver crystal from a previous crash.

## ENGINE SAFETY PRECAUTIONS

**Failure to follow these safety precautions may result in severe injury to yourself and others.**

- Keep all engine fuel in a safe place, away from high heat, sparks or flames, as fuel is very flammable. Do not smoke near the engine or fuel; and remember that engine exhaust gives off a great deal of deadly carbon monoxide. Therefore **do not run the engine in a closed room or garage.**
- Get help from an experienced pilot when learning to operate engines.
- Use safety glasses when starting or running engines.
- Do not run the engine in an area of loose gravel or sand; the propeller may throw such material in your face or eyes.
- Keep your face and body as well as all spectators away from the plane of rotation of the propeller as you start and run the engine.
- Keep these items away from the prop: loose clothing, shirt sleeves, ties, scarfs, long hair or loose objects such as pencils or screwdrivers that may fall out of shirt or jacket pockets into the prop.
- Use a “chicken stick” or electric starter to start the engine. Do not use your fingers to flip the propeller. Make certain the glow plug clip or connector is secure so that it will not pop off or otherwise get into the running propeller.
- Make all engine adjustments from behind the rotating prop.
- The engine gets hot! Do not touch it during or right after operation. Make sure fuel lines are in good condition so fuel will not leak onto a hot engine, causing a fire.
- **GASOLINE ENGINES CAN START BY A SIMPLE FLIP OF THE PROP, REGARDLESS IF THE MODEL'S RECEIVER SWITCH IS ON! ALWAYS UTILIZE BOTH KILL SWITCHES AND ENSURE BOTH SWITCHES ARE IN THE “OFF” POSITION WHEN THE MODEL IS NOT BEING FLOWN.**

## AMA SAFETY CODE (EXCERPTS)

Read and abide by the following excerpts from the Academy of Model Aeronautics Safety Code. For the complete Safety Code refer to *Model Aviation* magazine, the AMA web site or the Code that came with your AMA license.

### General

- 1) I will not fly my model aircraft in sanctioned events, air shows, or model flying demonstrations until it has been proven to be airworthy by having been previously, successfully flight tested.
- 2) I will not fly my model aircraft higher than approximately 400 feet within 3 miles of an airport without notifying the airport operator. I will give right-of-way and avoid flying in the proximity of full-scale aircraft. Where necessary, an observer shall be utilized to supervise flying to avoid having models fly in the proximity of full-scale aircraft.
- 3) Where established, I will abide by the safety rules for the flying site I use, and I will not willfully and deliberately fly my models in a careless, reckless and/or dangerous manner.
- 5) I will not fly my model unless it is identified with my name and address or AMA number, on or in the model. **Note:** This does not apply to models while being flown indoors.
- 7) I will not operate models with pyrotechnics (any device that explodes, burns, or propels a projectile of any kind).

### Radio Control

- 1) I will have completed a successful radio equipment ground check before the first flight of a new or repaired model.
- 2) I will not fly my model aircraft in the presence of spectators until I become a qualified flier, unless assisted by an experienced helper.
- 3) At all flying sites a straight or curved line(s) must be established in front of which all flying takes place with the other side for spectators. Only personnel involved with flying the aircraft are allowed at or in the front of the flight line. Intentional flying behind the flight line is prohibited.
- 4) I will operate my model using only radio control frequencies currently allowed by the Federal Communications Commission.
- 5) **I will not knowingly operate my model within three miles of any pre-existing flying site except in accordance with the frequency sharing agreement listed** [in the complete AMA Safety Code].
- 9) Under no circumstances may a pilot or other person touch a powered model in flight; **nor should any part of the model other than the landing gear, intentionally touch the ground, except while landing.**



## IMAA SAFETY CODE (EXCERPTS)

*Since the Great Planes 1/3-scale Matt Chapman CAP 580 qualifies as a "giant scale" model and is therefore eligible to fly in IMAA events, we've printed excerpts from the IMAA Safety Code which follows.*

### What is Giant-Scale?

The concept of large or giant-scale is generally considered to apply to radio controlled model aircraft with minimum wingspans of 80 inches for monoplanes and 60 inches for multi-wing aircraft. Quarter-scale or larger replicas of person-carrying aircraft with proper documentation (minimum 3-view drawing) which do not fit the size requirements will also be permitted.

### SECTION 1.0: SAFETY STANDARD

**1.1** Adherence to Code: The purpose of this Safety Code is to provide a structure whereby all participants, including spectators, will be aware of the inherent dangers in the operation of radio controlled aircraft. This code is meant to serve as a minimum guideline to all participants. It is understood that the ultimate responsibility for the safety of any aircraft lies with the owner(s), pilot(s) and spectator(s) involved in any event. It is the responsibility of all participants to exercise caution when operating, or observing the operation of all radio controlled aircraft. The pilot/owner of an aircraft will not be dissuaded from taking whatever steps they deem necessary, in addition to this code, to insure that their aircraft is safe. The most current AMA Safety Code in effect is to be observed.

### SECTION 3.0: SAFETY REVIEW

**3.4** Flight Testing: All aircraft are to have been flight tested and flight trimmed with a minimum of six (6) flights before the model is allowed to fly at an IMAA Sanctioned event.

**3.5** Proof of Flight: The completing and signing of the Declaration section of the Safety Review form (see Section 3.2) by the pilot (or owner) shall document, as fact, that the noted aircraft has been successfully flight-tested and proven airworthy prior to the IMAA event.

### SECTION 4.0: SPOTTER/HELPER

**4.1** Spotter/Helper Definition: An assistant to aid the pilot during start-up, and taxiing onto the runway. The spotter/helper will assist the pilot in completing a safe flight.

**4.2** Each pilot is required to have a spotter/helper at all IMAA sanctioned events. The event Safety Committee should be prepared to assist those pilots who do not have a spotter/helper to make sure that every registered pilot has the opportunity to fly at a sanctioned event.

### SECTION 5.0: EMERGENCY ENGINE SHUT OFF

#### (Kill Switch)

**5.1** Magneto spark ignition engines must have a coil-grounding switch on the aircraft to stop the engine. This will also prevent accidental starting of the engine. This switch shall be readily available to both pilot and spotter/helper. This switch is to be operated manually and without the use of the Radio System.

**5.2** Engines with battery powered ignition systems must have a switch to turn off the power from the battery pack to disable the engine from firing. This switch shall be readily available to both pilot and spotter/helper. This switch shall be operated manually and without the use of the Radio System.

**5.3** There must also be a means to stop the engine from the transmitter. The most common method is to completely close the carburetor throat using throttle trim. However, other methods are acceptable. This requirement applies to all glow/gas ignition engines regardless of size.

### SECTION 6.0: RADIO REQUIREMENTS

**6.1** All transmitters must be FCC type certified.

**6.2** FCC Technician or higher-class license required for 6 meter band operation only.

*The following recommendations are included in the Safety Code not to police such items, but rather to offer basic suggestions for enhanced safety. It is expected that IMAA members will avail themselves of technological advances as such become available, to promote the safety of all aircraft and participants.*

- Servos need to be of a rating capable to handle the loads that the control surfaces impose upon the servos. Standard servos are not recommended for control surfaces. Servos should be rated heavy-duty ounces of torque. For flight-critical control functions a minimum of 45 inch/ounces of torque should be considered. This should be considered a minimum for smaller aircraft and higher torque servos are strongly encouraged for larger aircraft. The use of one servo for each aileron and one for each stabilizer half is strongly recommended. Use of dual servos is also recommended on larger aircraft.

- On-board batteries should be, at a minimum, 1000 mAh up to 20 lbs., 1200 mAh to 30 lbs., 1800 mAh to 40 lbs., and 2000 mAh over 40 lbs. flying weight. The number and size of servos, size and loads on control surfaces, and added features should be considered as an increase to these minimums. Batteries should be able to sustain power to the onboard radio components for a minimum of one hour total flying time before recharging.

- Dependable, redundant and fail-safe battery systems are recommended.

- The use of anti-glitch devices for long leads is recommended.

- There is no maximum engine displacement limit, as it is the position of this body that an under powered aircraft presents a greater danger than an over powered aircraft. However, the selections of engine size relative to airframe strength and power loading mandates good discretionary judgment by the designer and builder. Current AMA maximums for engine displacement are 6.0 cu. in. for two-stroke and 9.6 cu. in. for four-stroke engines. These maximums apply only to AMA Sanction competition events such as 511, 512, 515 and 520. All non-competition events should be sanctioned as Class C events, in which these engine size maximums do not apply.

- Generally, it is recommended that no attempt should be made to fly a radio controlled model aircraft with a gasoline engine in which the model aircraft weight would exceed 12 pounds per cubic inch of engine displacement (under powered), or be less than 5 pounds per cubic inch of engine displacement (overpowered). Example: Using a 3 cu. in. engine, a model would likely be under powered at an aircraft weight greater than 36 pounds. With the same engine, an aircraft weighing less than 15 pounds would likely be overpowered.
- Servo arms and control horns should be rated heavy-duty. Glass filled servo arms and control horns are highly recommended.
- Control surface linkages are listed in order of preference:
  1. Cable system (pull-pull). A tiller bar is highly recommended along with necessary bracing.
  2. Arrow-shaft, fiberglass or aluminum, 1/4" or 5/16" OD. Bracing every six (6) to ten (10) inches is highly recommended.
  3. Tube-in-tube (Nyrod). Bracing every few inches is highly recommended. Inner tube should be totally enclosed in outer tube.
  4. Hardwood dowel, 3/8" OD. Bracing every six (6) to ten (10) inches is highly recommended.
- Hinges should be rated heavy-duty and manufactured primarily for use in giant-sized aircraft. Homemade and original design hinges are acceptable if determined to be adequate for the intended use.
- Clevis (steel, excluding heavy-duty ball links) and attachment hardware should be heavy-duty 4-40 thread-and-rod type. 2-56 thread size rod is acceptable for some applications (e.g. throttle). Clevises must have lock nuts and sleeve (fuel tubing) or spring keepers.
- Propeller tips should be painted or colored in a visible and contrasting manner to increase the visibility of the propeller tip arc.

## CHECKLIST

During the last few moments of preparation your mind may be elsewhere anticipating the excitement of the first flight. Because of this, you may be more likely to overlook certain checks and procedures that should be performed before the model is flown. To help avoid this, a check list is provided to make sure these important areas are not overlooked. Many are covered in the instruction manual, so where appropriate, refer to the manual for complete instructions. Be sure to check the items off as they are completed.

- 1. Fuelproof all areas exposed to fuel or exhaust residue such as the firewall, wing tube openings, etc.

- 2. Check the C.G. according to the measurements provided in the manual.
- 3. Be certain the battery and receiver are securely mounted in the fuse. Simply stuffing them into place with foam rubber is not sufficient.
- 4. Extend your receiver antenna and make sure it has a strain relief inside the fuselage to keep tension off the solder joint inside the receiver.
- 5. Balance your model *laterally* as explained in the instructions.
- 6. Use threadlocking compound to secure critical fasteners such as the set screws that hold the wheel axles to the struts, screws that hold the carburetor arm (if applicable), screw-lock pushrod connectors, etc.
- 7. Add a drop of oil to the axles so the wheels will turn freely.
- 8. Make sure all hinges are **securely** glued in place and that the hinge points have been oiled.
- 9. Reinforce holes for wood screws with thin CA where appropriate (servo mounting screws, cowl mounting screws, etc.).
- 10. Confirm that all controls operate in the correct direction and the throws are set up according to the manual.
- 11. Make sure there are silicone retainers on all the clevises and that all servo arms are secured to the servos with the screws included with your radio.
- 12. Secure connections between servo wires and Y-connectors or servo extensions, and the connection between your battery pack and the on/off switch with vinyl tape, heat shrink tubing or special clips suitable for that purpose.
- 13. Make sure any servo extension cords you may have used do not interfere with other systems (servo arms, pushrods, etc.).
- 14. Secure the pressure tap (if used) to the muffler with high temp RTV silicone, thread locking compound or J.B. Weld.
- 15. Make sure the fuel lines are connected and are not kinked.
- 16. Balance your propeller (and spare propellers).
- 17. Tighten the propeller nut and spinner.
- 18. Place your name, address, AMA number and telephone number on or inside your model.
- 19. Cycle your receiver battery pack (if necessary) and make sure it is fully charged.
- 20. If you wish to photograph your model, do so before your first flight.
- 21. Range check your radio when you get to the flying field.

## FLYING

### Fuel Mixture Adjustments

A fully cowled engine may run at a higher temperature than an un-cowled engine. For this reason, the fuel mixture should be richened so the engine runs at about 200 rpm below peak speed. By running the engine slightly rich, you will help prevent dead-stick landings caused by overheating.

**CAUTION** (THIS APPLIES TO ALL R/C AIRPLANES): If, while flying, you notice an alarming or unusual sound such as a low-pitched “buzz,” this may indicate control surface *flutter*. Flutter occurs when a control surface (such as an aileron or elevator) or a flying surface (such as a wing or stab) rapidly vibrates up and down (thus causing the noise). In extreme cases, if not detected immediately, flutter can actually cause the control surface to detach or the flying surface to fail, thus causing loss of control followed by an impending crash. The best thing to do when flutter is detected is to slow the model **immediately** by reducing power, then land as soon as safely possible. Identify which surface fluttered (so the problem may be resolved) by checking all the servo grommets for deterioration or signs of vibration. Make certain all pushrod linkages are secure and free of play. If it fluttered once, under similar circumstances it will probably flutter again unless the problem is fixed. Some things which can cause flutter are; Excessive hinge gap; Not mounting control horns solidly; Poor fit of clevis pin in horn; Side-play of wire pushrods caused by large bends; Excessive free play in servo gears; Insecure servo mounting; and one of the most prevalent causes of flutter; Flying an over-powered model at excessive speeds.

## Takeoff

Before you get ready to takeoff, see how the model handles on the ground by doing a few practice runs at **low speeds** on the runway. Hold a very small amount of “up” elevator to keep the tail wheel on the ground. If necessary, adjust the tail wheel so the model will roll straight down the runway. If you need to calm your nerves before the maiden flight, shut the engine down and bring the model back into the pits. Top off the fuel, then check all fasteners and control linkages for peace of mind.

Remember to takeoff into the wind. When you're ready, point the model straight down the runway, hold a bit of up elevator to keep the tail on the ground to maintain tail wheel steering, then gradually advance the throttle. As the model gains speed, decrease the up elevator, allowing the tail to come off the ground. One of the most important things to remember with a tail dragger is to always be ready to apply **right** rudder to counteract engine torque. Gain as much speed as your runway and flying site will practically allow before gently applying up elevator, lifting the model into the air. At this moment it is likely that you will need to apply more right rudder to counteract engine torque. Be smooth on the elevator stick, allowing the model to establish a **gentle** climb to a safe altitude before turning into the traffic pattern.

## Flight

For reassurance and to keep an eye on other traffic, it is a good idea to have an assistant on the flight line with you. Tell him to remind you to throttle back once the plane gets to a comfortable altitude. While full throttle is usually desirable for takeoff, most models fly more smoothly at reduced speeds.

Take it easy with the Great Planes 1/3-scale Matt Chapman CAP 580 ARF for the first few flights, gradually getting acquainted with it as you gain confidence. Adjust the trims to maintain straight and level flight. After flying around for a while, and while still at a safe altitude with plenty of fuel, practice slow flight and execute practice landing approaches by reducing the throttle to see how the model handles at slower speeds. Add power to see how she climbs as well. Continue to fly around, executing various maneuvers and making mental notes (or having your assistant write them down) of what trim or C.G. changes may be required to fine tune the model so it flies the way you like. Mind your fuel level, but use this first flight to become familiar with your model before landing.

## Landing

To initiate a landing approach, lower the throttle while on the downwind leg. Allow the nose of the model to pitch downward to gradually bleed off altitude. Continue to lose altitude, but maintain airspeed by keeping the nose down as you turn onto the crosswind leg. Make your final turn toward the runway (into the wind) keeping the nose down to maintain airspeed and control. Level the attitude when the model reaches the runway threshold, modulating the throttle as necessary to maintain your glide path and airspeed. If you are going to overshoot, smoothly advance the throttle (always ready on the right rudder to counteract torque) and climb out to make another attempt. When you're ready to make your landing flare and the model is a foot or so off the deck, smoothly increase up elevator until it gently touches down. Once the model is on the runway and has lost flying speed, hold up elevator to place the tail on the ground, regaining tail wheel control.

One final note about flying your model. Have a goal or flight plan in mind for **every** flight. This can be learning a new maneuver(s), improving a maneuver(s) you already know, practicing a competition sequence, or learning how the model behaves in certain conditions (such as on high or low rates). This is not necessarily to improve your skills (*though it is never a bad idea!*), but more importantly so you do not surprise yourself by impulsively attempting a maneuver and suddenly finding that you've run out of time, altitude or airspeed. Every maneuver should be deliberate, not impulsive. For example, if you're going to try your first blender, check your altitude, mind the wind direction, remind yourself of the proper procedure to exit, and make certain you are on the desired rates (high/low rates). A flight plan greatly reduces the chances of crashing your model just because of poor planning and impulsive moves. **Remember to think.**

**Have a ball!**

**But always stay in control and fly in a safe manner.**

**GOOD LUCK AND GREAT FLYING!**

