

# GIANT U-Can-Do 3D<sup>™</sup> ARF

## INSTRUCTION MANUAL

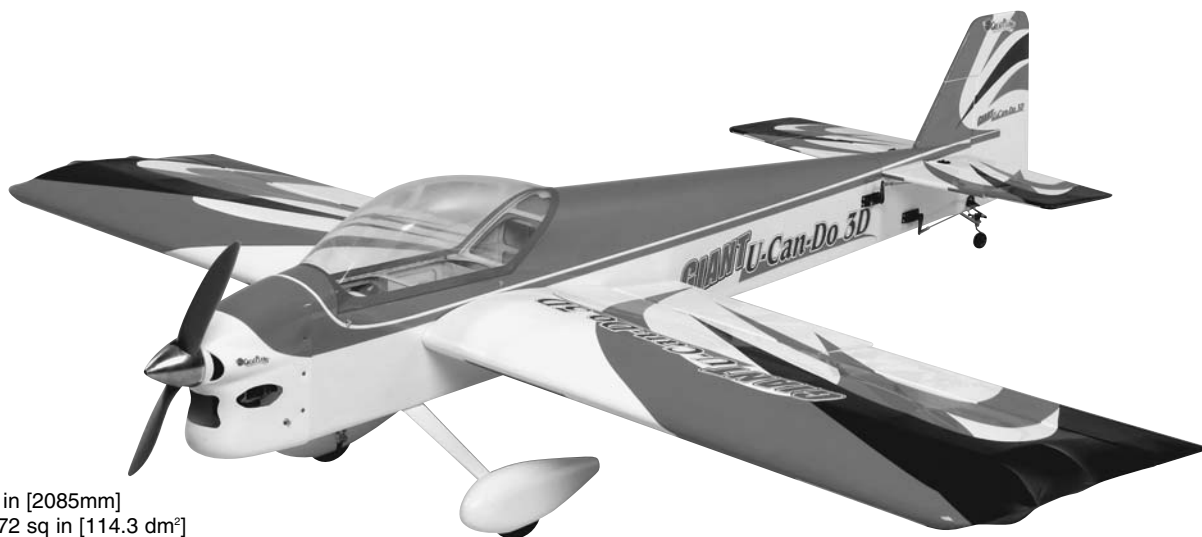

**Wingspan:** 82 in [2085mm]  
**Wing Area:** 1772 sq in [114.3 dm<sup>2</sup>]  
**Weight:** 12.5 – 13.5 lb [5600 – 6070g]  
**Wing Loading:** 16.1 – 17.4 oz/sq ft [49 – 53 g/dm<sup>2</sup>]  
**Length:** 84 in [2135mm]  
**Engine:** 1.20 – 1.60 cu in [19.5 – 26.0cc] glow,  
2.0 – 2.5 cu in [32.5 – 41.0cc] gas

### WARRANTY

Great Planes<sup>®</sup> Model Manufacturing Co. guarantees this kit to be free from defects in both material and workmanship at the date of purchase. This warranty does not cover any component parts damaged by use or modification. **In no case shall Great Planes' liability exceed the original cost of the purchased kit.** Further, Great Planes reserves the right to change or modify this warranty without notice.

In that Great Planes has no control over the final assembly or material used for final assembly, no liability shall be assumed nor accepted for any damage resulting from the use by the user of the final user-assembled product. By the act of using the user-assembled product, the user accepts all resulting liability.

**If the buyer is not prepared to accept the liability associated with the use of this product, the buyer is advised to return this kit immediately in new and unused condition to the place of purchase.**

To make a warranty claim send the defective part or item to Hobby Services at the address below:

**Hobby Services**  
3002 N. Apollo Dr., Suite 1  
Champaign, IL 61822  
USA

Include a letter stating your name, return shipping address, as much contact information as possible (daytime telephone number, fax number, e-mail address), a detailed description of the problem and a photocopy of the purchase receipt. Upon receipt of the package the problem will be evaluated as quickly as possible.

**READ THROUGH THIS MANUAL BEFORE STARTING CONSTRUCTION. IT CONTAINS IMPORTANT WARNINGS AND INSTRUCTIONS CONCERNING THE ASSEMBLY AND USE OF THIS MODEL.**



Champaign, IL  
(217) 398-8970, Ext. 5  
airsupport@greatplanes.com

## TABLE OF CONTENTS

|  |    |
|--|----|
| INTRODUCTION .....                                   | 2  |
| SAFETY PRECAUTIONS .....                             | 2  |
| DECISIONS YOU MUST MAKE .....                        | 3  |
| Radio Equipment .....                                | 3  |
| Engine Recommendations .....                         | 3  |
| ADDITIONAL ITEMS REQUIRED .....                      | 3  |
| Hardware & Accessories .....                         | 3  |
| Covering Tools .....                                 | 4  |
| Adhesives & Building Supplies .....                  | 4  |
| Optional Supplies & Tools .....                      | 4  |
| IMPORTANT BUILDING NOTES .....                       | 4  |
| KIT INSPECTION .....                                 | 5  |
| ORDERING REPLACEMENT PARTS .....                     | 6  |
| METRIC CONVERSIONS .....                             | 6  |
| PREPARATIONS .....                                   | 6  |
| Assemble the Pushrods .....                          | 6  |
| ASSEMBLE THE WING .....                              | 7  |
| Mount the Ailerons & Flaps .....                     | 7  |
| Hook Up the Flaps & Ailerons .....                   | 9  |
| ASSEMBLE THE FUSELAGE .....                          | 10 |
| Mount the Wing .....                                 | 10 |
| Mount the Stab & Fin .....                           | 10 |
| Mount the Landing Gear .....                         | 11 |
| Mount the Engine .....                               | 13 |
| Mount the Cowl .....                                 | 13 |
| Install the Fuel Tank .....                          | 15 |
| FINAL ASSEMBLY .....                                 | 16 |
| Mount the Tail Servos .....                          | 16 |
| Install the Throttle Servo, Receiver & Battery ..... | 17 |
| Mount the Canopy .....                               | 18 |
| Apply the Decals .....                               | 18 |
| GET THE MODEL READY TO FLY .....                     | 19 |
| Check the Control Directions .....                   | 19 |
| Set the Control Throws .....                         | 19 |
| Balance the Model (C.G.) .....                       | 19 |
| Balance the Model Laterally .....                    | 20 |
| PREFLIGHT .....                                      | 20 |
| Identify Your Model .....                            | 20 |
| Charge the Batteries .....                           | 20 |
| Balance the Propellers .....                         | 20 |
| Ground Check .....                                   | 21 |
| Range Check .....                                    | 21 |
| ENGINE SAFETY PRECAUTIONS .....                      | 21 |
| AMA SAFETY CODE (excerpts) .....                     | 21 |
| CHECK LIST .....                                     | 22 |
| FLYING .....   | 22 |
| Important Reminders .....                            | 22 |
| Fuel Mixture Adjustments .....                       | 22 |
| Take Off .....                                       | 23 |
| Flight .....   | 23 |
| Landing .....  | 23 |

## INTRODUCTION

Whether you're just learning to do basic aerobatics or are looking for a quick practice plane as a backup to your \$10,000 Unlimited aerobatic machine, the Giant U-CAN-DO 3D™ ARF is just the bird you're looking for.

Large control surfaces, light wing loading and an all around performance design work together to put a fun-to-fly, do-it-all 3D aerobatic machine in your hands. On low rates, the Giant U-CAN-DO 3D ARF is a perfect choice for learning to do basic aerobatics or for great Sunday fun flying. With an O.S.® 1.60 and high 3D rates, the Giant U-CAN-DO 3D ARF provides exceptional slow speed and below-stall-speed (3D) aerobatic ability with vertical performance that is exhilarating.

For the latest technical updates or manual corrections to the Giant U-CAN-DO 3D ARF, visit the web site listed below and select the Giant U-CAN-DO 3D ARF. If there is new technical information or changes to this model, a "tech notice" box will appear in the upper left corner of the page.

<http://www.greatplanes.com/airplanes/index.html>

### PROTECT YOUR MODEL, YOURSELF & OTHERS...FOLLOW THESE IMPORTANT SAFETY PRECAUTIONS

1. Your Giant U-CAN-DO 3D ARF should not be considered a toy, but rather a sophisticated, working model that functions very much like a full-size airplane. Because of its performance capabilities, the Giant U-CAN-DO 3D ARF, if not assembled and operated correctly, could possibly cause injury to yourself or spectators and damage to property.
2. You must assemble the model **according to the instructions**. Do not alter or modify the model, as doing so may result in an unsafe or unflyable model. In a few cases the instructions may differ slightly from the photos. In those instances the written instructions should be considered as correct.
3. You must take time to **build straight, true and strong**.
4. You must use an R/C radio system that is in first-class condition and a correctly sized engine and components (fuel tank, wheels, etc.) throughout the building process.
5. You must correctly install all R/C and other components so that the model operates correctly on the ground and in the air.
6. You must check the operation of the model before **every** flight to insure that all equipment is operating and that the model has remained structurally sound. Be sure to check

clevises or other connectors often and replace them if they show any signs of wear or fatigue.

7. If you are not already an experienced R/C pilot, you should fly the model only with the help of a competent, experienced R/C pilot.

8. **WARNING:** The cowl and wheel pants included in this kit are made of fiberglass, the fibers of which may cause eye, skin and respiratory tract irritation. Never blow into a part to remove fiberglass dust, as the dust will blow back into your eyes. Always wear safety goggles, a particle mask and rubber gloves when grinding, drilling and sanding fiberglass parts. Vacuum the parts and work area thoroughly after working with fiberglass parts.

**Note:** We, as the kit manufacturer, provide you with a top quality kit and great instructions, but ultimately the quality and flyability of your finished model depends on how you build it; therefore, we cannot in any way guarantee the performance of your completed model, and no representations are expressed or implied as to the performance or safety of your completed model.

**Remember: Take your time and follow the instructions to end up with a well-built model that is straight and true.**

If you have not flown this type of model before, we recommend that you get the assistance of an experienced pilot in your R/C club for your first flights. If you're not a member of a club, your local hobby shop has information about clubs in your area whose membership includes experienced pilots.

In addition to joining an R/C club, we strongly recommend you join the AMA (Academy of Model Aeronautics). AMA membership is required to fly at AMA sanctioned clubs. There are over 2,500 AMA chartered clubs across the country. Among other benefits, the AMA provides insurance to its members who fly at sanctioned sites and events. Additionally, training programs and instructors are available at AMA club sites to help you get started the right way. Contact the AMA at the address or toll-free phone number that follows.



**Academy of Model Aeronautics**  
5151 East Memorial Drive  
Muncie, IN 47302-9252  
Tele: (800) 435-9262  
Fax (765) 741-0057  
Or via the Internet at:  
<http://www.modelaircraft.org>

## DECISIONS YOU MUST MAKE

This is a partial list of items required to finish the Giant U-CAN-DO 3D ARF that may require planning or decision-making before starting to build. Order numbers are provided in parentheses.

## Radio Equipment

4+ channel radio with 8 standard-sized servos. Note that a 9+ channel, fully computerized radio system is highly recommended for maximum flexibility and performance.

### Ailerons:

- (2) 50+ oz/in Ball bearing servos Futaba S9001 (FUTM0075)
- (2) 20" extensions (FUTM4147)
- (2) 8" extensions (FUTM4140)

### Flaps:

- (2) 50+ oz/in oz ball bearing servos Futaba S9001 (FUTM0075)
- (2) 8" extensions (FUTM4140)

### Rudder:

- (1) 90+ oz/in High torque servos Futaba S9206 (FUTM0115)
- (1) 40" servo extension (FUTM4148)

### Elevator:

- (2) 90+ oz/in Ball bearing servos Futaba S9206 (FUTM0115)
- If using a computerized radio, two 40" servo extensions (FUTM4148)
- If not using a computerized radio with Ailevator programming, then a servo reversing harness (FUTM4150) and a 20" extension (FUTM4147) are required.

### Throttle:

- (1) Standard servo: Futaba S3003 (FUTM0031)

## Engine Recommendations

- 1.20 to 1.60 cu in [19.5-26.0cc] glow, 2.0 to 2.5 cu in [32.5-41cc] gas
- Appropriate props, fuel, glow plugs, etc. for your engine

**Engine Notes:** The Giant U-CAN-DO 3D ARF will hover on all of the recommended engines. The engines on the lower end of the range will hover nicely without over-speeding the airframe in level flight. The engines on the higher end of the range will hover and give the added power to recover from unwanted attitudes, but throttle management needs to be used to keep the speed down. **Whatever engine you choose, an 8 pitch prop or less is recommended.**

## ADDITIONAL ITEMS REQUIRED

### Hardware & Accessories

In addition to the items listed in the "**Decisions You Must Make**" section, following is the list of hardware and

accessories required to finish the Giant U-CAN-DO 3D ARF. Order numbers are provided in parentheses.

- Hook & Loop Velcro (GPMQ4480)
- 3' Medium fuel tubing (GPMQ4131)
- 1/2" R/C Foam (HCAQ1050)

### Covering Tools

- 21st Century® sealing iron (COVR2700)
- 21st Century trim seal iron (COVR2750)
- 21st Century iron cover (COVR2702)

### Adhesives & Building Supplies

In addition to common household tools and hobby tools, this is the “short list” of the most important items required to build the Giant U-CAN-DO 3D ARF. **Great Planes Pro™ CA and Epoxy glue are recommended.**

- 1/2 oz. Thin Pro CA (GPMR6001)
- 1/2 oz. Medium Pro CA+ (GPMR6007)
- 6-Minute Epoxy (GPMR6045)
- 30-Minute Epoxy (GPMR6047)
- Small T-pins (HCAR5100)
- Electric drill
- Drill bit set including: 1/16" [1.6mm], 5/64" [2mm], 3/32" [2.4mm], and 1/8" [3mm]
- Small Phillips and flat blade screwdrivers (HCAR1040)
- Pliers with wire cutter (HCAR0630)
- Standard hex wrench set (HCAR0520)
- Threadlocker™ (GPMR6060)
- Rotary tool such as Dremel®
- Rotary tool reinforced cut-off wheel (GPMR8200)

### Optional Supplies & Tools

Here is a list of optional tools mentioned in the manual that will help you build the Giant U-CAN-DO 3D ARF.

- Great Planes CG Machine™ (GPMR2400)
- Top Flite® Precision Magnetic Prop Balancer™ (TOPQ5700)
- Cutting mat (HCAR0456)
- CA Applicator Tips (GPMR6033)
- CA Debonder (GPMR6039)
- CA Accelerator (GPMR6034)
- Epoxy Brushes (GPMR8060)
- Mixing Sticks (GPMR8055)
- Denatured Alcohol (for epoxy clean up)
- Hobby knife (HCAR0105), #11 blades (HCAR0211)
- Builders Triangle Set (HCAR0480) (for fin alignment)
- Felt-Tip marker (TOPQ2510)
- Small metal file
- Dead Center™ Engine Mount Hole Locator (GPMR8130)
- Great Planes AccuThrow™ Deflection Gauge (for measuring control throws, GPMR2405)
- Great Planes Aluminum Fuel Line Plug (GPMQ4166)

## IMPORTANT BUILDING NOTES

**Sheet metal screws** are designated by a number and a length. For example, #6 x 3/4" [19mm].

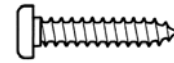

*This is a number six screw that is 3/4" [19mm] long.*

**Machine screws** are designated by a number, **threads per inch**, and a length – for example, 4-40 x 3/4" [19mm].



*This is a number four screw that is 3/4" [19mm] long with forty threads per inch.*

When you see the term **test fit** in the instructions, it means that you should first position the part on the assembly **without using any glue**, then slightly modify or *custom fit* the part as necessary for the best fit.

Whenever the term **glue** is written you should rely upon your experience to decide what type of glue to use. When a specific type of adhesive works best for that step, the instructions will make a recommendation.

Whenever just **epoxy** is specified you may use **either** 30-minute (or 45-minute) epoxy **or** 6-minute epoxy.

**Photos** and **sketches** are placed **before** the step they refer to. Frequently you can study photos in following steps to get another view of the same parts.

The Giant U-CAN-DO 3D ARF is factory-covered with Top Flite MonoKote® film. Should repairs ever be required, MonoKote can be patched with additional MonoKote purchased separately. MonoKote is packaged in six-foot rolls, but some hobby shops also sell it by the foot. If only a small piece of MonoKote is needed for a minor patch, perhaps a fellow modeler would give you some. MonoKote is applied with a model airplane covering iron, but in an emergency a regular iron could be used. A roll of MonoKote includes full instructions for application. Following are the colors used on this model and order numbers for six foot rolls.

Jet White – TOPQ0204  
Medium Purple – TOPQ0225  
Sky Blue – TOPQ0206  
Pink – TOPQ0215

## KIT INSPECTION

Before starting to build, use the **Kit Contents** list to take an inventory of this kit to make sure it is complete and inspect the parts to make sure they are of acceptable quality. If any parts are missing or are not of acceptable quality, or if you need assistance with assembly, contact **Great Planes Product Support**. When reporting defective or missing parts, use the part names exactly as they are written in the Kit Contents list on this page.

**Great Planes Product Support:**  
**3002 N. Apollo Drive, Suite 1**  
**Champaign, IL 61822**  
**Telephone: (217) 398-8970, ext. 5**  
**Fax: (217) 398-7721**  
**E-mail: [airsupport@greatplanes.com](mailto:airsupport@greatplanes.com)**

### Parts Layout

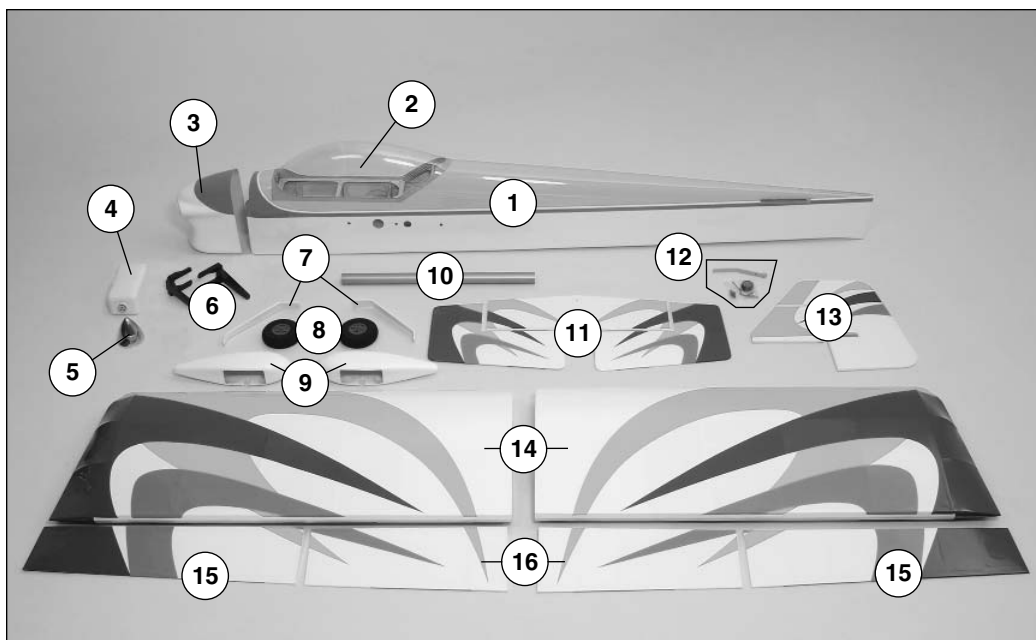

#### Kit Contents

1. Fuselage
2. Canopy
3. Cowl
4. Fuel Tank
5. Spinner
6. Engine Mount
7. Main Landing Gear (2)
8. Wheels (2)
9. Wheel Pants (2)
10. Wing Tube
11. Horizontal Stabilizer & Elevator
12. Tail Gear Assembly
13. Vertical Fin & Rudder
14. Wing Panels (L&R)
15. Ailerons (L&R)
16. Flaps (L&R)

#### Kit Contents (Not Photographed)

- |  |   |  |
|--|---|--|
| <ul style="list-style-type: none"> <li>(1) Prop Nut Bag (prop nut, spinner, SHCS and hex wrench)</li> <li>(8) Heavy Duty Control Horns</li> <li>(2) Nylon Wing Bolt</li> <li>(4) Nylon Anti-Rotation Dowels</li> <li>(1) Tail Wheel Assembly (1-1/4" wheel, 6" springs, leaf spring, Tail wheel wire, 4 set screws, steering arm and 3 wheel collars)</li> <li>(1) Fuel Tank and Hardware</li> <li>(1) 1/4" x 5/8" [6 x 16mm] Canopy Dowel</li> <li>(1) Rx and Battery Tray</li> <li>(1) 3/16" x 3/4" x 4-3/8" [4.8 x 19 x 112mm] Tank Retainer Stick</li> <li>(2) Velcro® Strips (both A and B sides)</li> <li>(2) Tail Gear Springs (use to steer the tail wheel)</li> <li>(2) Large Black Control Horn Backplate (for elevators)</li> <li>(2) Decal Sheet</li> <li>(8) 4-40 Threaded Steel Clevis (for aileron, flap, rudder and elevator controls)</li> <li>(8) 4-40 Solder-On Clevis (for aileron, flap, rudder and elevator controls)</li> </ul> | <ul style="list-style-type: none"> <li>(2) 3-16 x 2" [50mm] Axles</li> <li>(1) Brass Screw-Lock Pushrod Connector Body (for throttle)</li> <li>(6) 4-40 Blind Nut (for canopy mounting)</li> <li>(10) 8-32 Blind Nuts (for stab, main gear and engine mount)</li> <li>(2) 5/16-24 Nuts (for axles)</li> <li>(2) 1/4-20 Blind Nuts</li> <li>(8) 4-40 Lock Nuts (for clevises)</li> <li>(4) 4-40 Lock Nuts (for rudder control horns)</li> <li>(1) 2-56 Nylon Clevis</li> <li>(1) Nylon Retainer (for throttle)</li> <li>(2) CA Hinge Strip</li> <li>(1) 36" [915mm] Gray Pushrod Tube (installed in the fuse for the antenna)</li> <li>(1) 12" [305mm] Gray Pushrod Tube (for throttle)</li> <li>(17) Silicone Clevis Retainers</li> <li>(16) 4 x 1/2" [13mm] Screws (for aileron and flap control horns)</li> <li>(4) 6-32 Set Screws</li> <li>(2) #4 x 5/8" [16mm] Screws (for tail gear)</li> </ul> | <ul style="list-style-type: none"> <li>(1) 4-40 x 1/4" [6mm] SHCS (for throttle)</li> <li>(6) #2 x 1/2" [13mm] screws (for cowl)</li> <li>(4) 8-32 x 3/4" [19mm] SHCS (for main gear)</li> <li>(4) 4-40 x 1" [25mm] SHCS (for rudder control horns)</li> <li>(10) 4-40 x 3/4" [19mm] SHCS (for elevators and canopy mounting)</li> <li>(4) 4-40 x 1/2" [13mm] SHCS (for wheel pants)</li> <li>(2) 8-32 x 1-1/4" [32mm] SHCS (for stab)</li> <li>(8) 8-32 x 1" [25mm] SHCS (for engine mount to the firewall and engine to mount)</li> <li>(4) 3/16" [4.8mm] Wheel Collars</li> <li>(1) 2-56 x 17" [430mm] Pushrod</li> <li>(7) 4-40 x 12" [305mm] Pushrod</li> <li>(6) #2 Flat Washers (for cowl)</li> <li>(12) #8 Lock Washers (for engine, engine mount, landing gear and stab)</li> <li>(14) #8 Flat Washers (for engine, engine mount, landing gear and stab)</li> <li>(6) #4 Flat Washers (for canopy and wheel pants)</li> </ul> |
|--|---|--|

## ORDERING REPLACEMENT PARTS

Replacement parts for the Giant U-CAN-DO 3D ARF are available using the order numbers in the Replacement Parts List that follows. The fastest, most economical service can be provided by your hobby dealer or mail-order company. Parts may also be ordered directly from Hobby Services, but full retail prices and shipping and handling charges will apply. Illinois and Nevada residents will also be charged sales tax.

To locate a hobby dealer, visit the Great Planes web site at [www.greatplanes.com](http://www.greatplanes.com). Choose "Where to Buy" at the bottom of the menu on the left side of the page. Follow the instructions provided on the page to locate a U.S., Canadian or International dealer. If a hobby shop is not available, replacement parts may also be ordered from Tower Hobbies at [www.towerhobbies.com](http://www.towerhobbies.com), or by calling toll free (800) 637-6050, or from Hobby Services by calling (217) 398-0007, or via facsimile at (217) 398-7721. If ordering via fax, include a Visa® or MasterCard® number and expiration date for payment.

Mail parts orders and payments by personal check to:

**Hobby Services**  
3002 N Apollo Drive, Suite 1  
Champaign IL 61822

Be certain to specify the order number exactly as listed in the **Replacement Parts List**. Payment by credit card or personal check only; no C.O.D.

If additional assistance is required for any reason, contact the appropriate Product Support by e-mail or by telephone at (217) 398-8970.

[partssupport@greatplanes.com](mailto:partssupport@greatplanes.com)

### REPLACEMENT PARTS LIST

| Order Number | Description        | How to Purchase |
|--------------|--------------------|-----------------|
| GPMA2379     | Fuselage Kit       | Hobby Supplier  |
| GPMA2378     | Wing Kit           | Hobby Supplier  |
| GPMA2380     | Tail Set           | Hobby Supplier  |
| GPMA2382     | Landing Gear       | Hobby Supplier  |
| GPMA2381     | Fiberglass Cowl    | Hobby Supplier  |
| GPMA2387     | Canopy/Hatch       | Hobby Supplier  |
| GPMA2383     | Wheel Pants        | Hobby Supplier  |
| GPMA2388     | Decal Sheet        | Hobby Supplier  |
| GPMA2385     | Tailwheel Assembly | Hobby Supplier  |
| GPMA2384     | Aluminum Spinner   | Hobby Supplier  |
| GPMA2386     | Aluminum Wing Tube | Hobby Supplier  |
| GPMA2389     | Nylon Wing Bolts   | Hobby Supplier  |
| GPMP0199     | Instruction Manual | Product Support |
|              | Missing pieces     | Product Support |
|              | Full-size plans    | Not Available   |

## METRIC CONVERSIONS

1" = 25.4mm (conversion factor)

|                |                |
|----------------|----------------|
| 1/64" = .4 mm  | 3/4" = 19.0 mm |
| 1/32" = .8 mm  | 1" = 25.4 mm   |
| 1/16" = 1.6 mm | 2" = 50.8 mm   |
| 3/32" = 2.4 mm | 3" = 76.2 mm   |
| 1/8" = 3.2 mm  | 6" = 152.4 mm  |
| 5/32" = 4.0 mm | 12" = 304.8 mm |
| 3/16" = 4.8 mm | 18" = 457.2 mm |
| 1/4" = 6.4 mm  | 21" = 533.4 mm |
| 3/8" = 9.5 mm  | 24" = 609.6 mm |
| 1/2" = 12.7 mm | 30" = 762.0 mm |
| 5/8" = 15.9 mm | 36" = 914.4 mm |

## PREPARATIONS

1. If you have not yet done so already, remove the major parts of the kit from the box (wings, fuse, wheel pants, cowl, tail parts, etc.) and inspect them for damage. If any parts are damaged or missing, contact Product Support at the telephone number on page 5.
2. Carefully remove the masking tape and separate the ailerons from the wing, the rudder from the fin and the elevators from the stab. Where necessary, use a covering iron with a covering sock to tighten the covering that may have loosened during storage or from removing the masking tape. Apply pressure over sheeted areas and the servo openings to **thoroughly** bond the covering to the wood.

### Assemble the Pushrods

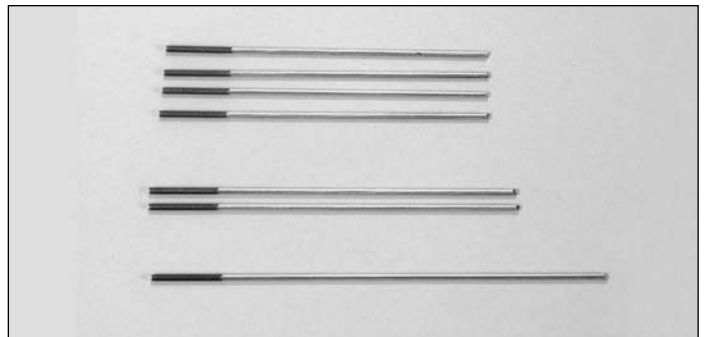

1. Cut the seven 4-40 x 12" [305mm] pushrods as listed below.
  - A. (4) 5" [127mm].
  - B. (2) 5-1/2" [140mm].
  - C. (1) 6-3/4" [172mm].

❑ 2. Use denatured alcohol or other solvent to thoroughly clean one of the pushrods. Use coarse sandpaper to roughen the end of the pushrod where it is to be soldered.

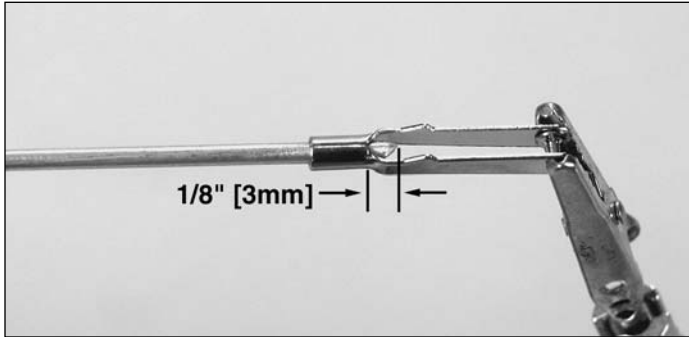

❑ 3. Apply a few drops of soldering flux to the end of the pushrod. Position the clevis so that 1/8" [3mm] of the pushrod protrudes into the open area of the clevis.

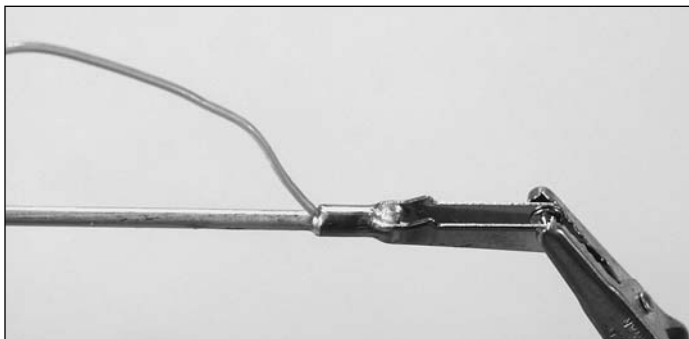

❑ 4. Simultaneously heat the clevis and pushrod. Apply silver solder (GPMR8070) to the joint. The heat of the parts being soldered should melt the solder, thus allowing it to flow.

❑ 5. Immediately after the solder has solidified, but while it is still hot, carefully use a cloth to quickly wipe off the flux before it hardens. **IMPORTANT:** After the joint cools, coat with oil to prevent rust. **Note:** Do not use the acid flux that comes with silver solder for electrical soldering.

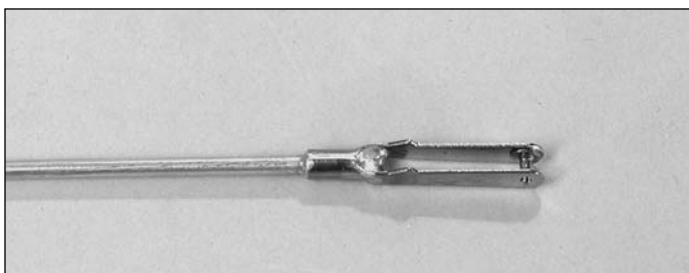

❑ 6. This is what a properly soldered clevis looks like; shiny solder with good flow, no blobs, flux removed.

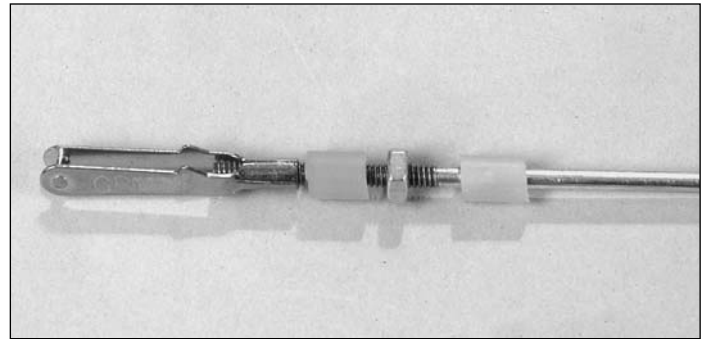

❑ 7. Fit a silicone clevis retainer, 4-40 nut, another silicone clevis retainer and the clevis on the other end of the pushrod.



❑ 8. Make the remaining six pushrods the same way. **Note:** The amount that the clevis screws onto the pushrod will be adjusted when they are installed.

## ASSEMBLE THE WING

### Mount the Ailerons & Flaps

*Do the right wing first.*

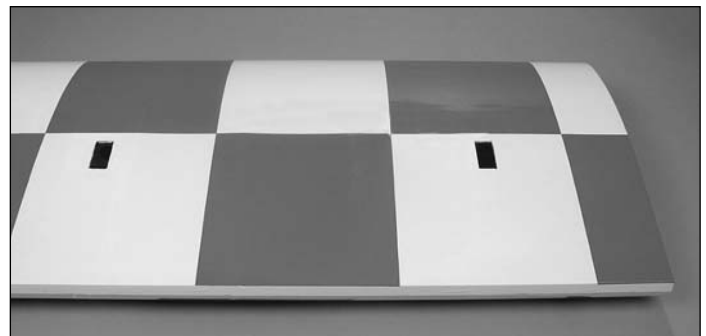

❑ 1. Trim the covering from both servo openings on the bottom of the wing.

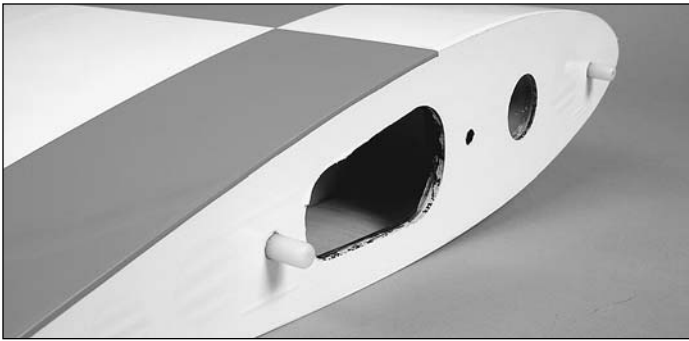

2. Use epoxy to glue in the two nylon wing dowels.

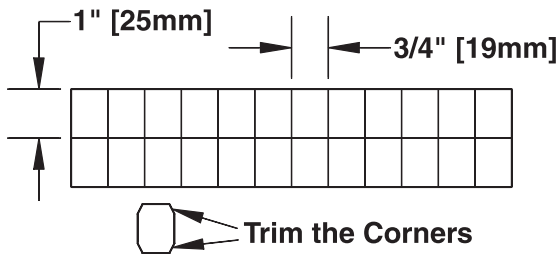

3. Cut eight  $3/4$ " x 1" [19 x 25mm] hinges from the 2" x 9" [50 x 230mm] CA hinge strip. Snip the corners off so they go in easier.



4. Test fit the hinges in the hinge slots of the aileron, flap and the wing. If you have difficulty inserting the hinges, insert a #11 blade into the slot and carefully move it back and forth to slightly widen the slot.

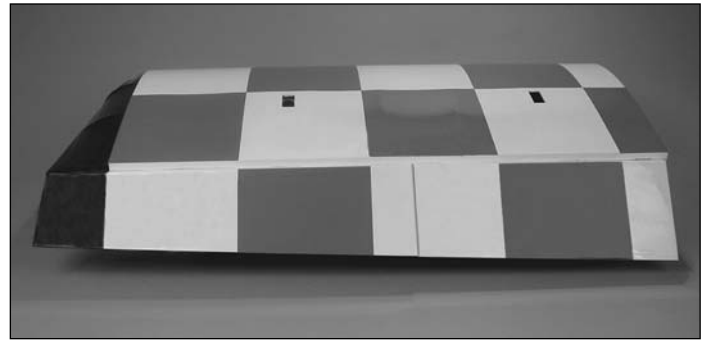

5. Test fit the aileron and flap to the wing with the hinges. Use a fine-point ballpoint pen to mark the aileron, flap and wing at the middle of each hinge. **Note:** Align the outer tip of the aileron with the outer tip of the wing. Leave a  $1/8$ " [3mm] gap between the flap and the aileron.

6. Separate the aileron and flap from the wing and take out all the hinges.

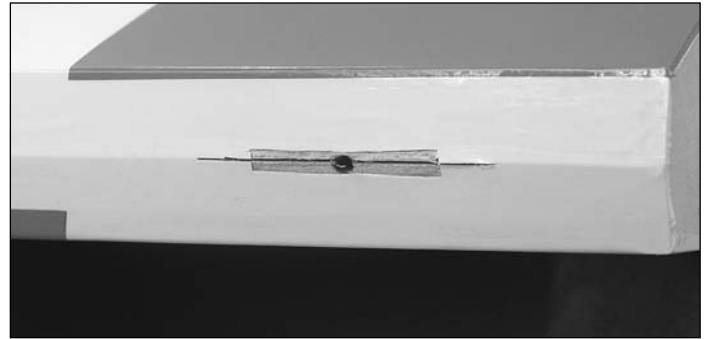

7. Drill a  $3/32$ " [2.4mm] hole,  $1/2$ " [13mm] deep at the marks you made in the center of each hinge slot. This space will allow the CA to "wick" in. Follow with a #11 blade to clean out the slots. **Hint:** If available, use a high-speed rotary tool to drill the holes.

8. Cut a small strip of covering from both sides of each hinge slot. If this is not done the covering may interfere with the penetration of the CA into the slot and may also interfere with the free movement of the aileron.

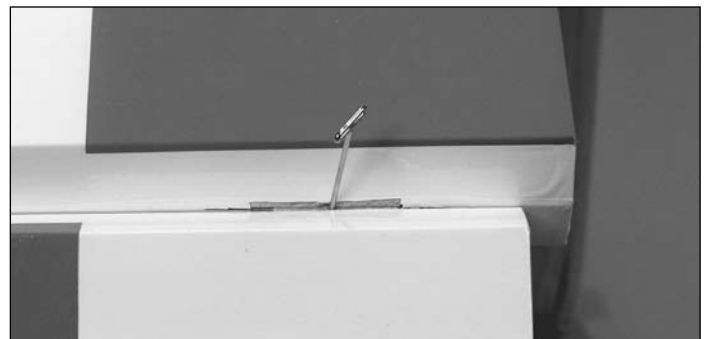

9. Stick a pin through the center of each hinge. Fit the aileron and flap to the wing with the hinges. The pin will keep the hinge centered. Remove the pins from the hinges. Adjust the aileron and flaps so there is a small gap—just enough to see light through or to slip a piece of paper through.



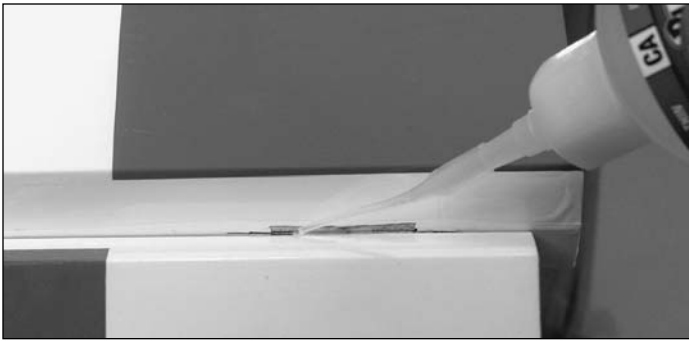

10. Apply six drops of thin CA to the top and bottom side of each hinge. Do not use CA accelerator. After the CA has fully hardened, test the hinges by pulling on the aileron and flap.

11. Repeat steps 1 to 10 for the left wing half.

### Hook Up the Flaps & Ailerons

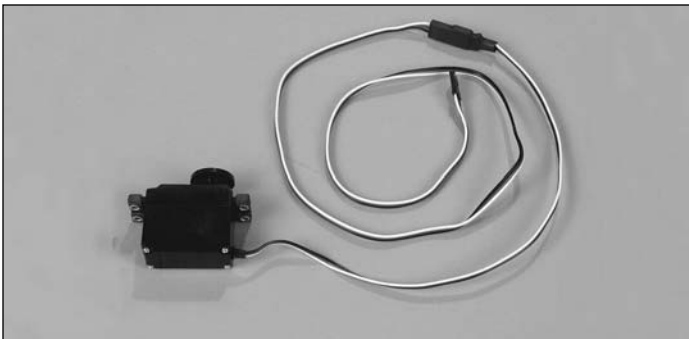

1. Add a servo extension to the aileron servo, so that the total length of the lead will be at least 30" [760mm] from the servo to the end of the extension. Using tape or heat-shrink tubing, securely attach the servo extension to the servo.

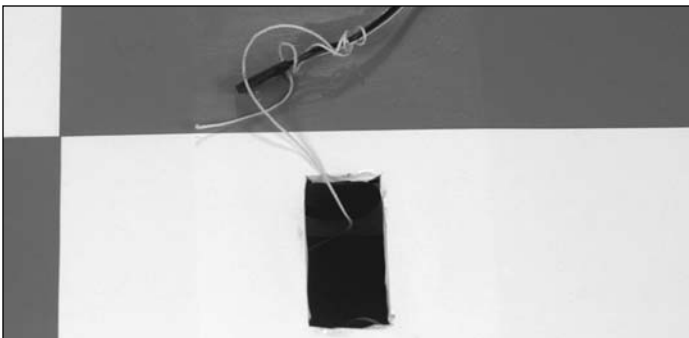

2. Using needle nose pliers, pull the string out of the right aileron servo hole. Tie the string to the end of the servo lead. **Note:** Take care not to pull the string loose from the root end of the wing.

3. Use the string to pull the servo wire through the wing. Fit the aileron servo in the wing. Slide the flap servo lead through the wing and fit the flap servo.

4. Drill 1/16" [1.6mm] holes through the servo mounts for the servo screws. Add a few drops of thin CA to the holes and allow to fully harden. Mount the aileron and flap servos using the hardware that came with the servos.

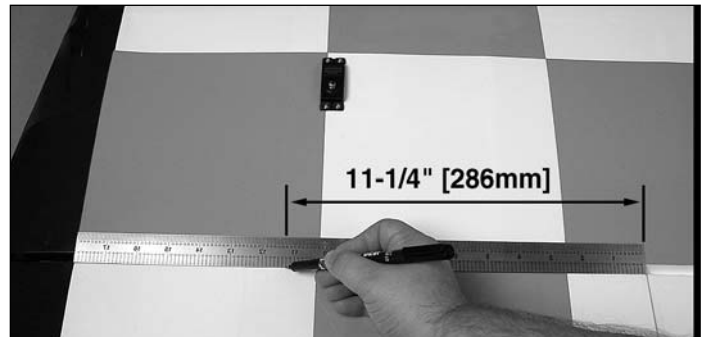

5. Mark the bottom LE of the right aileron 11-1/4" [286mm] from the inboard end.

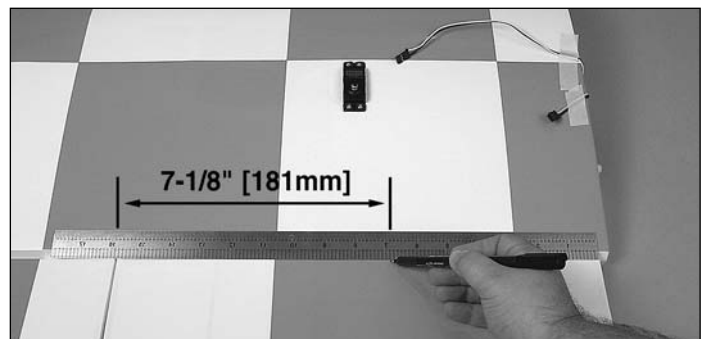

6. Mark the bottom LE of the right flap 7-1/8" [181mm] from the inboard end of the **aileron**.



7. Center the control horns on the marks you made and align the LE of the control horn with the LE of the control surface. Drill 1/16" [1.6mm] holes through the plywood plates using the control horns as a guide. **Note:** Take care to not drill through the top of the control surface.

8. Mount the control horns using #4 x 1/2" [13mm] screws. Remove the screws and harden the threads in the wood with thin CA. Mount the control horns the second time.

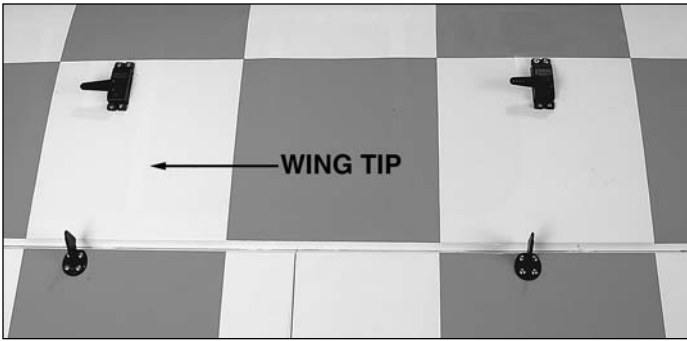

□ □ 9. Turn on the transmitter and receiver to center the servo. Place the servo arm on the servo. **Note:** For best performance 1-1/4" [32mm] long servo arms are recommended.



□ □ 10. Attach two of the shortest pushrods to the outer holes on the servo arms and the control horns. Adjust the length of the pushrods so that the aileron aligns with the wing tip. Adjust the flap pushrod so that the flap aligns with the aileron.

□ 11. Repeat steps 2 to 10 for the left wing half.

## ASSEMBLE THE FUSELAGE

### Mount the Wing



□ 1. Remove the covering from the wing tube holes, servo lead holes, wing bolt holes and anti-rotation dowel holes.

□ 2. Using a 9/64" hex wrench, remove the two 8-32 x 1-1/4" [32mm] socket head cap screws from the stab fillet.

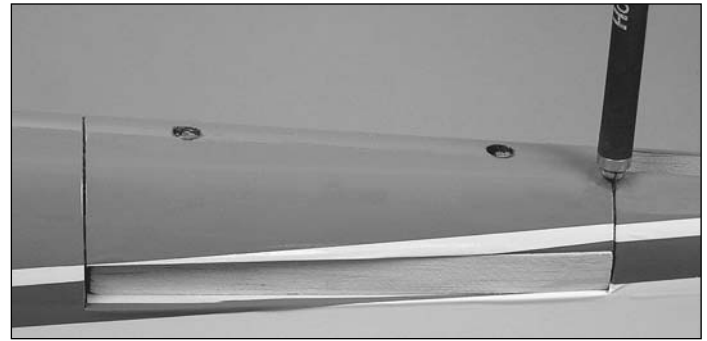

□ 3. Use a #11 blade to cut between the false stab and the stab fillet.



□ 4. Fit the aluminum wing tube through the fuse. Slide the wing panels on the tube and bolt them in place with the 1/4-20 x 1" [25mm] nylon bolts.

### Mount the Stab & Fin

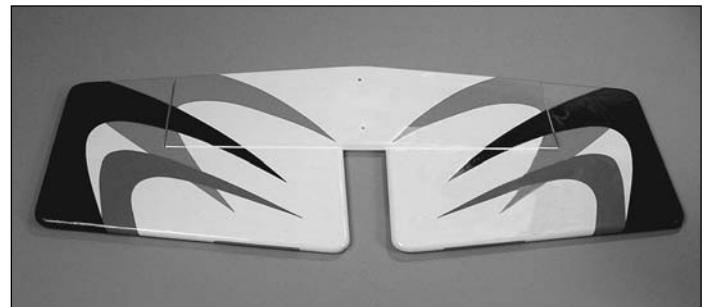

□ 1. Attach the elevators to the stab with the same hinging technique used for the ailerons.

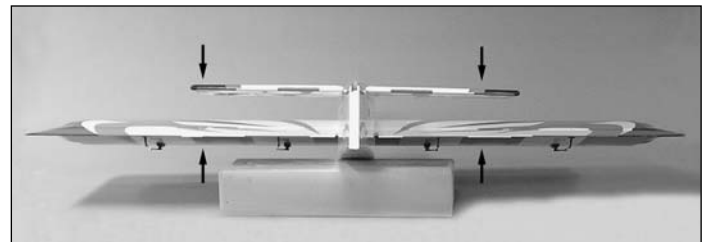

□ 2. Bolt the stab and stab fillet in place with the 8-32 x 1-1/4" [32mm] socket head cap screws. Check that the stab aligns with the wing. If it does not, sand the stab saddle in small increments until they do align. **Note:** If you don't plan on removing the stab, glue the bolts in with medium CA. If

you do plan on removing it, make sure to check the tightness of the screws often.

- ❑ 3. Use a #11 blade to remove the covering from the fin slot.



- ❑ 4. Fit the fin in place and mark the covering on the fin where it contacts the fuse.

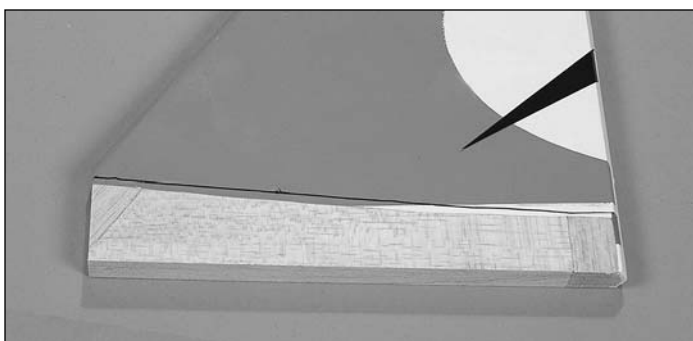

- ❑ 5. Refer to the **Expert Tip** that follows, then trim the covering 1/8" [3mm] below the lines you made on the fin. Be very careful not to cut into the fin itself. Wipe away the marks on the fin you made in the previous step. The epoxy used in the next step will make removing those lines difficult. DO NOT remove the covering from the TE of the fin.



#### HOW TO CUT COVERING FROM Balsa

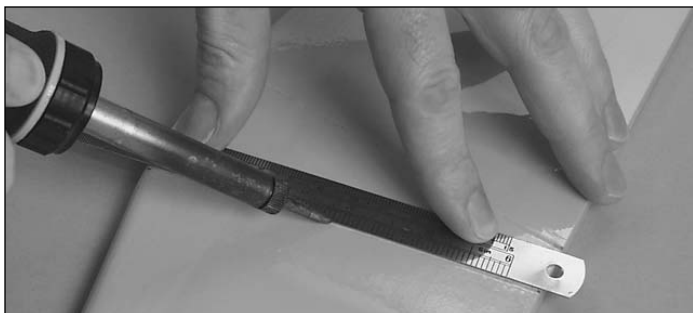

*To avoid cutting into the balsa, use a soldering iron instead of a hobby knife to cut the covering. The tip of the soldering iron doesn't have to be sharp, but a fine tip does work best. Allow the iron to heat fully. Use a straightedge to guide the soldering iron at a rate that will just melt the covering and not burn into the wood. The hotter the soldering iron, the faster it must move to melt a fine cut.*

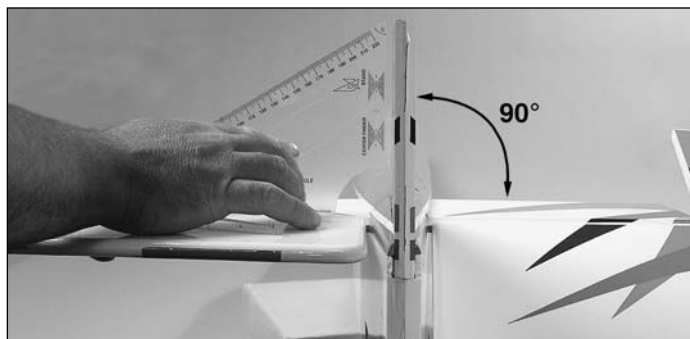

- ❑ 6. Check that the fin is perpendicular to the stab. If it's not, then adjust the fin slot until the fin is perpendicular to the stab.

- ❑ 7. If you want the stab to be removable, remove the stab so that the epoxy from the fin does not mistakenly glue the stab. Apply 6-minute epoxy to all joining surfaces of the fin. Fit the fin in place, aligning the TE of the fin with the TE of the fuse.



- ❑ 8. Attach the rudder to the fin with the same hinging technique used for the ailerons.

#### Mount the Landing Gear

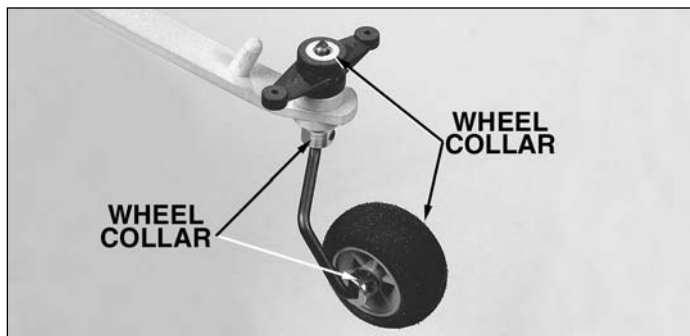

- ❑ 1. Temporarily assemble the tail gear, making a point to mark the tail gear wire with the set screws.

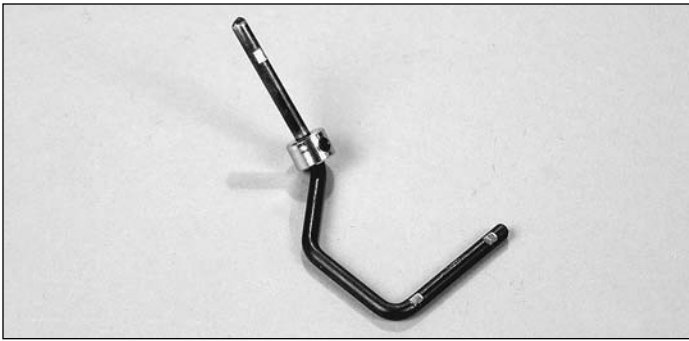

❑ 2. Remove steering arm and tailwheel from the wire. File flat spots on the wire for the set screws. **Note:** DO NOT file a flat spot for the wheel collar shown on the wire as this will weaken the wire at a high stress point.

❑ 3. Re-assemble the tail gear.



❑ 4. Place the tail gear on the bottom of the fuse, aligning the bend of the gear with the aft end of the fuse. Drill two 1/16" [1.6mm] pilot holes for the #4 x 5/8" [16mm] screws. Turn the screws into the holes. Remove the screws and harden the threads in the wood with thin CA. Remount the tail gear.



❑ 5. Remove the covering from the four landing gear bolt holes. Mount the landing gear to the fuse with four 8-32 x 3/4" [19mm] SHCS, #8 flat washers and #8 lock washers. Be sure to add a drop of Threadlocker to each screw and securely tighten.



❑ 6. Mount the 3/16" x 2" [4.8 x 50mm] axles to the landing gear with the 5/16-24 nuts.



❑ 7. Temporarily mount a wheel to one axle with two 3/16" [4.8mm] wheel collars aligning the outer wheel collar with the end of the axle.



❑ 8. Remove the wheel collars from the axle and file flat spots on the axle for the set screws.

❑ 9. Add a drop of Threadlocker to the set screw. Install the wheel collars and wheels.



❑ 10. Fasten the wheel part to the landing gear with two 4-40 x 1/2" [13mm] screws.

❑ 11. Return to step 7 and mount the other wheel and part to the left landing gear the same way.

## Mount the Engine

❑ 1. Draw a vertical line on the firewall using the embossed lines as a guide. **Note:** This line is offset to the left so that the spinner will be centered on the cowl.



❑ 2. Trim the spreader bars from both halves of the engine mount. Mount the engine mount to the firewall with four 8-32 x 1" [25mm] SHCS, #8 flat washers and #8 lock washers, but do not fully tighten the bolts.



❑ 3. Adjust the width of the mount to fit the engine. Center the molded-in "tick" marks on the engine mount equally to the left and right of the vertical line on the firewall. Tighten the mounting bolts.



❑ 4. Place the backplate of the spinner on the engine.

❑ 5. Use small clamps or another method to temporarily secure the engine to the mount with the backplate of the spinner 6" [152mm] from the firewall. Use the Great Planes Dead Center™ Engine Mount Hole Locator (GPMR8130) or your preferred method to mark the engine mount holes onto the engine mount.

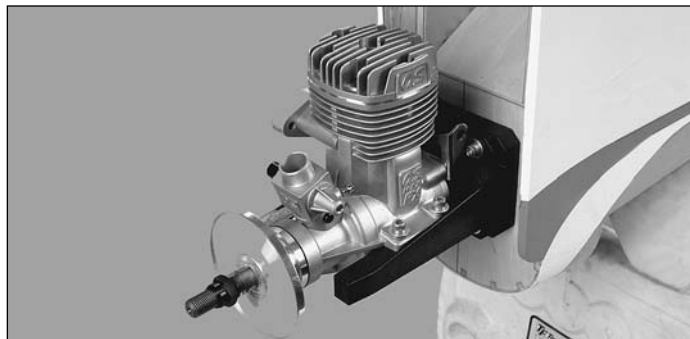

❑ 6. Remove the engine from the mount. Drill #29 holes through the mount at the marks you made. Tap 8-32 threads into the mount. Mount the engine to the mount with four 8-32 x 1" [25mm] SHCS, #8 flat washers and #8 lock washers.

## Mount the Cowl



❑ 1. Place the cowl on the fuse. Mount the spinner and prop to the engine. Position the cowl on the fuse so it is in alignment with the spinner. Be certain there is at least a 3/32" [2.5mm] gap between the front of the cowl and the backplate of the spinner. It may be helpful to have an assistant hold the cowl for you.



❑ 2. Drill a 1/16" [1.6mm] hole through the cowl and fuse side centered vertically and 1/2" [13mm] forward of the aft edge of the cowl. Mount the cowl to the fuse with a #2 x 1/2" [13mm] screw and a #2 washer.

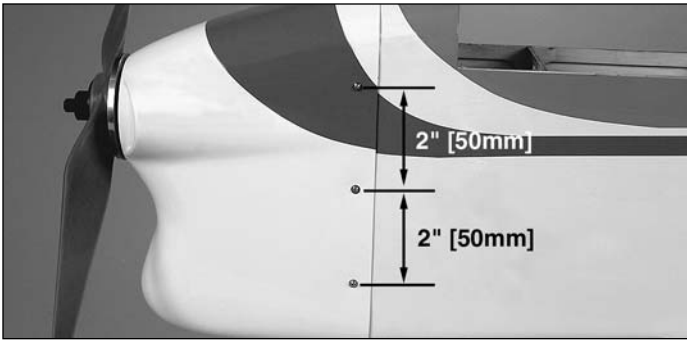

❑ 3. With your assistant holding the cowl in position, drill holes 2" [50mm] above and below the first screw. Secure this side of the cowl with two more #2 x 1/2" [13mm] screws and #2 washers.



❑ 4. Secure the other side of the cowl with three #2 x 1/2" [13mm] screws and #2 washers.

❑ 5. Remove the cowl. Harden the threads in the fuse with thin CA.

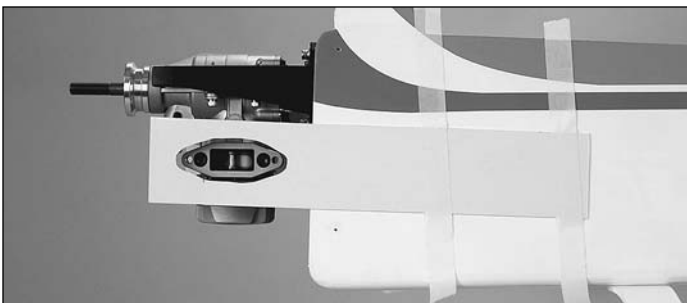

❑ 6. Use thin cardboard or plastic to make templates for the muffer, mixture screw, filler valve and glow plug cutouts in the cowl. Tape the template(s) to the fuselage, accurately indicating the positions. **Note:** With this engine installation we installed the muffer bolts through two 1/4" [6mm] holes in the right side of the cowl.

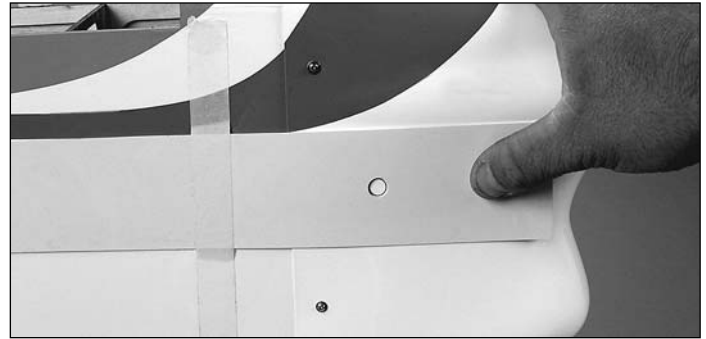
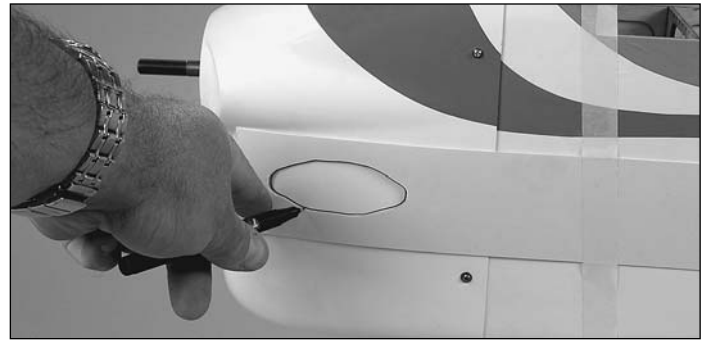

❑ 7. Remount the cowl under the templates. Use a felt-tip pen to transfer the holes in the template onto the cowl. Remove the templates and the cowl.

❑ 8. Cut out the holes in the cowl with a high-speed rotary tool and a small cutting bit.



❑ 9. Cut the air opening in the front of the cowl as shown. The shape of the hole is not that important, but you'll need a hole at least as big as shown in the photo. **Note:** Do not remount the cowl. The fuel tank, fuel line and throttle pushrod still need to be installed.

## Install the Fuel Tank



- ❑ 1. Roughen the outside of the 11-3/4" [300mm] gray outer pushrod tube with coarse sand paper. Fit the tube through the firewall and the second former, leaving 1/2" [13mm] protruding from the firewall. Glue the tube to the firewall and the second former with thin CA.

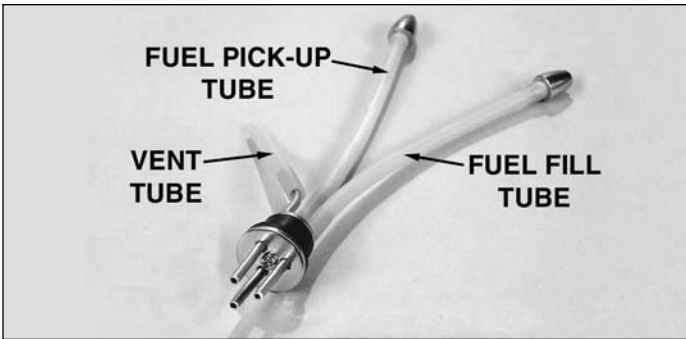

- ❑ 2. Arrange the stopper and tubes as shown in the photo, then insert them into the fuel tank. Tighten the screw to expand the stopper, thus sealing the fuel tank. Be certain the fuel line weights (clunks) at the end of the fuel lines inside the fuel tank do not contact the rear of the fuel tank. Otherwise, the lines may become stuck above the fuel level and discontinue fuel flow. Remember (or use a felt-tip pen to mark) the fuel pick-up tube, fuel fill tube and the vent tube (that will be connected to the pressure fitting on the engine's muffler).

- ❑ 3. Install the fuel tank in the fuse. Fit the neck through the hole in the firewall. Be certain the vent tube inside the fuel tank is pointing upward.



- ❑ 4. Glue a 1/4" x 3/4" x 4-7/16" [6 x 19 x 123mm] balsa stick to the fuse to hold the fuel tank in place.

- ❑ 5. Attach a piece of fuel line to one of the tubes that has a clunk on it and the fuel inlet tube on your engine.



- ❑ 6. Drill a 1/4" [6mm] hole, 1" [25mm] above the motor mount.

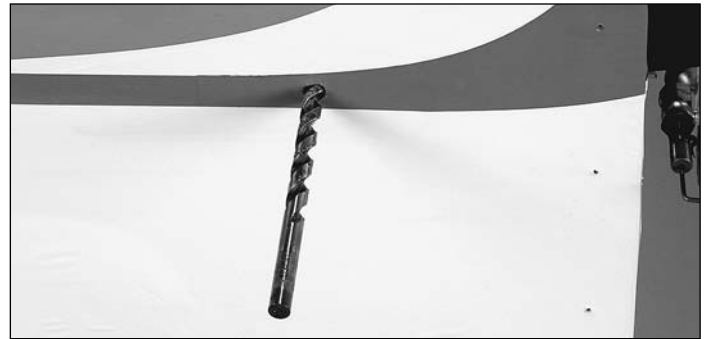

- ❑ 7. Drill a 1/4" [6mm] hole in the side of the fuse in roughly the spot shown. **Note: Take special care to not drill into the fuel tank.**



- ❑ 8. Harden the hole in the balsa fuselage side with thin CA. After the CA has hardened attach fuel line to the second tube that has a clunk on it and route it through the hole in the firewall and the hole in the side of the fuse. Cut the fuel line so that 4" [100mm] is protruding from the fuse side. Use a Great Planes Aluminum Fuel Line Plug (not included) to plug this fill line.

- ❑ 9. Attach a piece of fuel line to the vent tube on the fuel tank and leave it long enough to reach the pressure tap on the muffler.

## FINAL ASSEMBLY

### Mount the Tail Servos

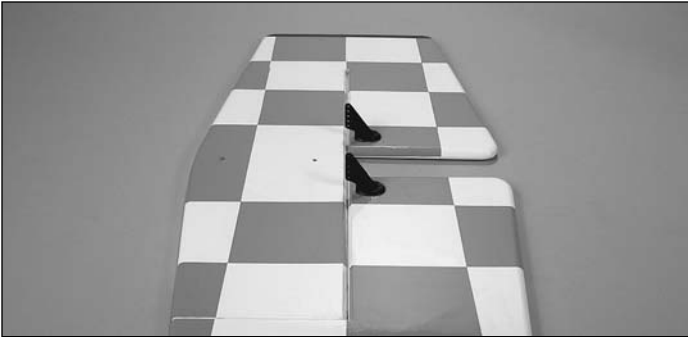

❑ 1. Add servo extensions to the three tail surface servos so that the total length of each lead will be at least 48" [1220mm] from the servo to the end of the extension. Using tape or heat-shrink tubing, securely attach the servo extension to the servo. **Note:** Use 36" [914mm] extensions with Futaba servos to get the 48" [1220mm] length.



❑ 2. Trim the covering from the three tail servo holes. Fit the servos in the fuselage, feeding the wires forward to the hatch opening. **Note:** The servo output shafts on all the tail servos go toward the rear of the airplane.

❑ 3. Drill 1/16" [1.6mm] holes through the servo mount for the servo screws. Insert the servo screws and remove them, then harden the holes with thin CA. Mount the tail servos using the hardware that came with the servos.

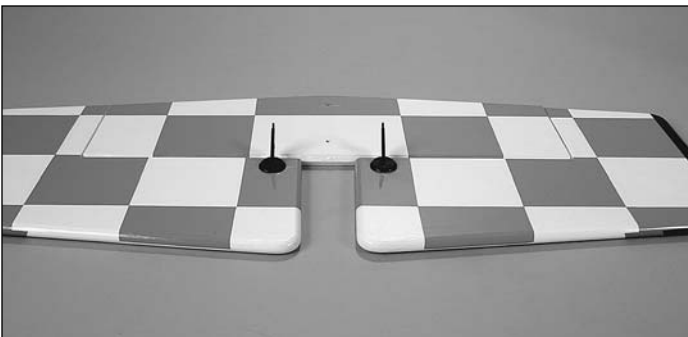

❑ 4. Mark the bottom LE of both elevators 1" [25mm] from the inboard edge. Position the control horns centered over the marks with the clevis holes perpendicular to the hinge

line. Mark the hole locations on the elevators. Drill 1/8" [3mm] holes through the elevators at each of the marks.

❑ 5. Mount the control horns using the 4-40 x 3/4" [19mm] SHCS and the nylon backing plate on the top of the elevators.

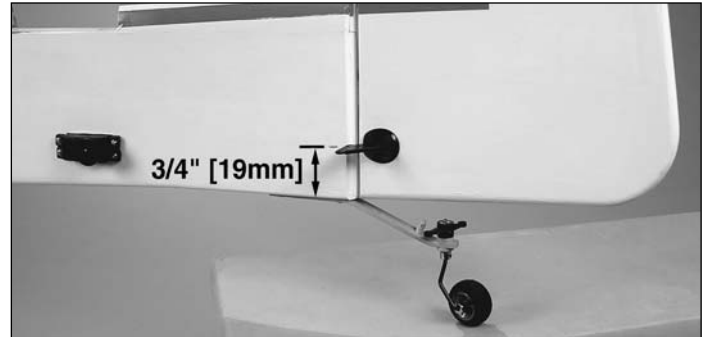

❑ 6. Make a mark 3/4" [19mm] from the bottom of the rudder. Position the control horn centered over the mark with the clevis holes perpendicular to the hinge line. Mark the hole locations on the rudder. Drill 1/8" [3mm] holes through the rudder at each of the marks.

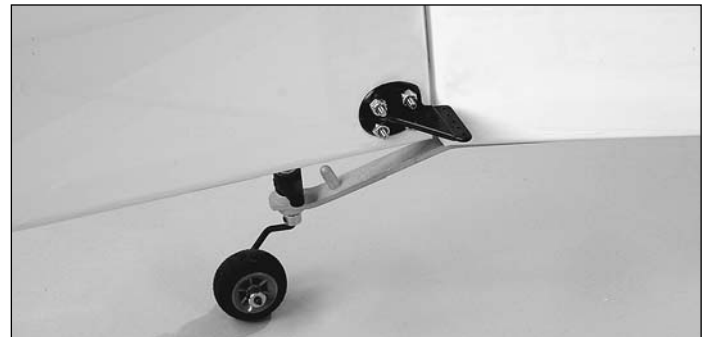

❑ 7. Fit the first control horn onto the rudder with four 4-40 x 1" [25mm] SHCS. Attach the second control horn to the other side of the rudder with four 4-40 lock nuts.

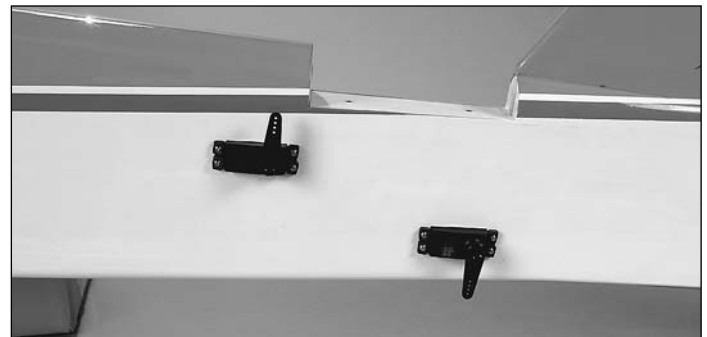

❑ 8. Turn on the transmitter and receiver to center the servo. Place the elevator arms pointing straight up and the rudder servo arm straight down. **Note:** For best performance 1-1/4" [32mm] long servo arms are recommended.



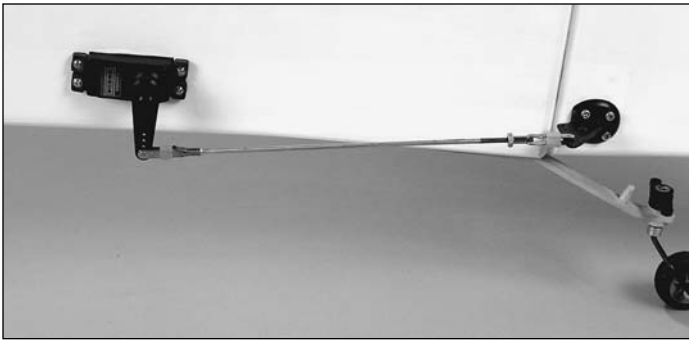

❑ 9. Attach the 6-3/4" [172mm] pushrod to the outer holes on the rudder servo arm and the second to outer hole on the control horn. Adjust the length of the pushrod so that the rudder lines up with the fin.

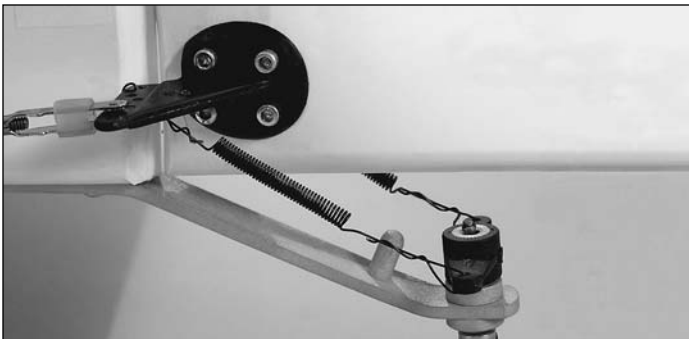

❑ 10. Attach the two tail gear springs to the inner holes on the control horns and the tail gear steering arm. Wrap the ends around the wires at least twice and trim off the excessive wire.

❑ 11. Mount the stab to the fuse.



❑ 12. Attach the 5-1/2" [140mm] pushrods to the outer holes on the elevator servo arms and the middle hole on the control horns. Adjust the length of the pushrods so that the elevators line up with the stab.

❑ 13. Double-check that the elevators align with the stab and the rudder aligns with the fin. Tighten the 4-40 nuts against the clevises. Slide the silicone retainers over the clevises.

## Install the Throttle Servo, Receiver & Battery



❑ 1. Screw the nylon clevis 15 full turns onto the 17-1/2" [445mm] throttle pushrod. Slide the throttle pushrod into the plastic outer pushrod tube, attaching the clevis to the throttle arm. **Note:** Bend the pushrod as necessary for smooth operation.

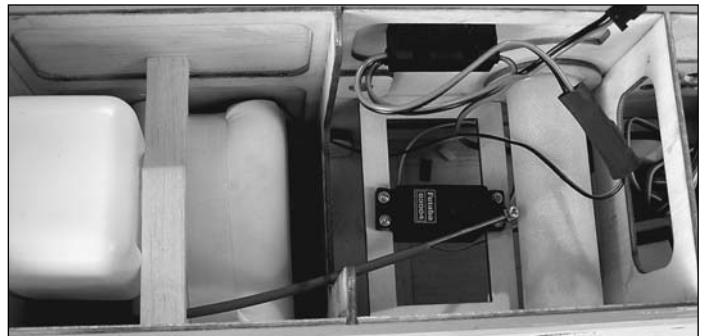

❑ 2. Fit the throttle servo in the tray, but do not screw it in place at this time.

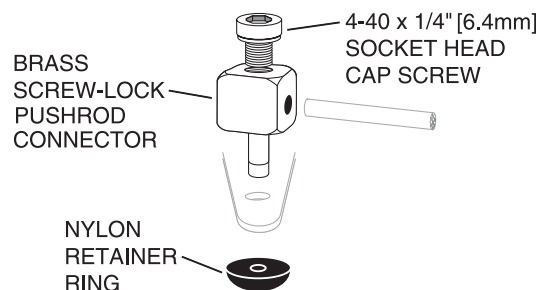

❑ 3. Connect the throttle pushrod to the throttle servo with the screw-lock pushrod connector.

❑ 4. Let the pushrod locate the servo in the tray. Mount the servo to the servo tray with the hardware provided with your servo.

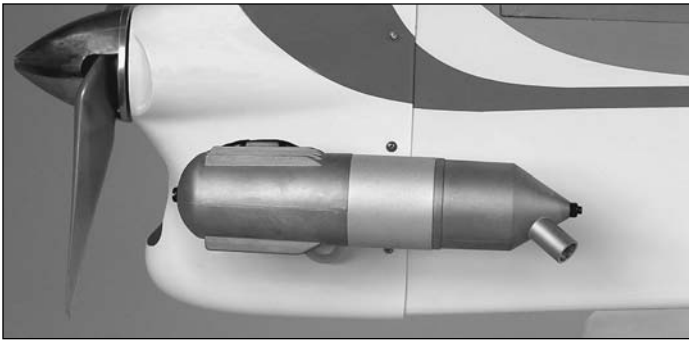

- ❑ 5. Mount the cowl, prop, muffler and spinner.

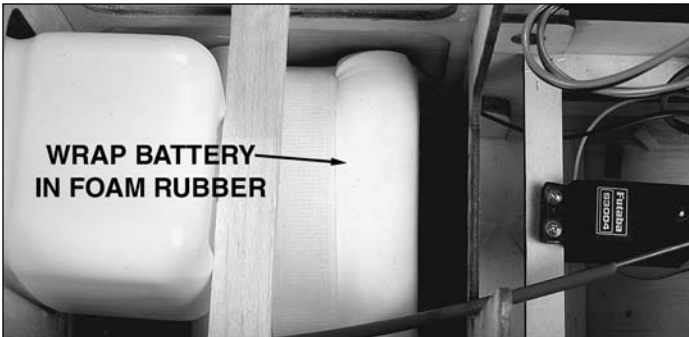

- ❑ 6. Wrap the battery pack in 1/2" [13mm] of R/C foam rubber and use the Velcro® strap to mount it to one of the battery/receiver trays. Fit the tray in the fuselage under the fuel tank and glue it to the fuse sides with medium CA.

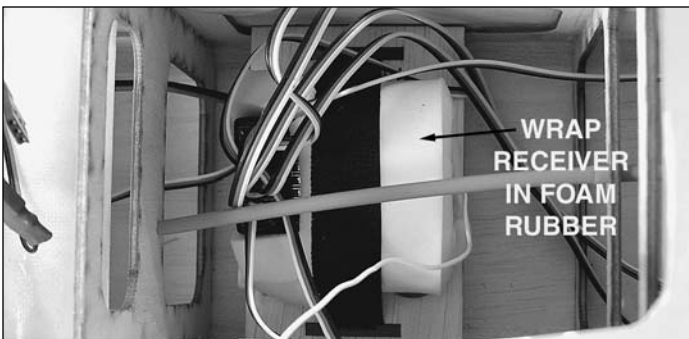

- ❑ 7. Wrap the receiver in 1/2" [13mm] of R/C foam rubber and use the Velcro strap to mount it to one of the battery/receiver trays. Fit the tray in the fuselage behind the wing tube and glue it to the fuse sides with medium CA.

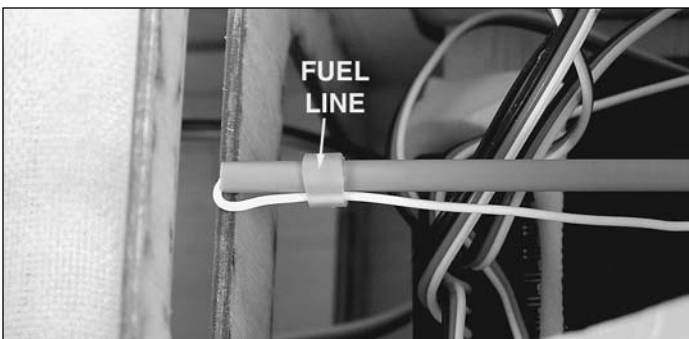

- ❑ 8. Extend the receiver antenna and guide it down the antenna tube in the fuse. Retain the end of the antenna with a 1/4" [6mm] piece of fuel line slid over the antenna tube.



- ❑ 9. Mount the receiver on/off switch and charge jack.

### Mount the Canopy

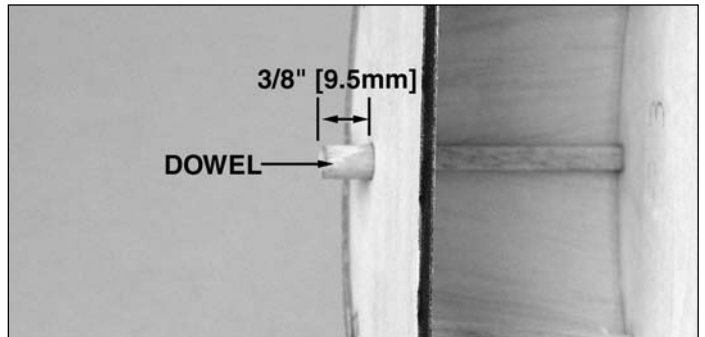

- ❑ 1. Glue the 1/4" x 5/8" [6 x 16mm] dowel in the hole in the front of the canopy hatch assembly.



- ❑ 2. Mount the hatch to the fuse with two 4-40 x 3/4" [19mm] SHCS.

### Apply the Decals

- ❑ 1. Use scissors or a sharp hobby knife to cut the decals from the sheet.
- ❑ 2. Be certain the model is clean and free from oily fingerprints and dust. Prepare a dishpan or small bucket with a mixture of liquid dish soap and warm water—about one teaspoon of soap per gallon of water. Submerge the decal in the soap and water and peel off the paper backing.

**Note:** Even though the decals have a “sticky-back” and are not the water transfer type, submersing them in soap & water allows accurate positioning and reduces air bubbles underneath.

❑ 3. Position decal on the model where desired. Holding the decal down, use a paper towel to wipe most of the water away.

❑ 4. Use a piece of soft balsa or something similar to squeegee remaining water from under the decal. Apply the rest of the decals the same way.

## GET THE MODEL READY TO FLY

### Check the Control Directions

❑ 1. Turn on the transmitter and receiver and center the trims. If necessary, remove the servo arms from the servos and reposition them so they are centered. Reinstall the screws that hold on the servo arms.

❑ 2. With the transmitter and receiver still on, check all the control surfaces to see if they are centered. If necessary, adjust the clevises on the pushrods to center the control surfaces.

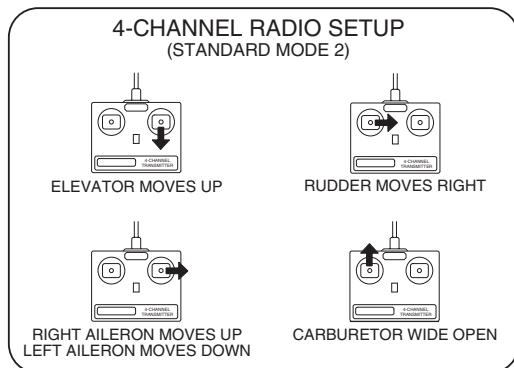

❑ 3. Make certain that the control surfaces and the carburetor respond in the correct direction as shown in the diagram. If any of the controls respond in the wrong direction, use the servo reversing in the transmitter to reverse the servos connected to those controls. Confirm the control surfaces have remained centered. Adjust if necessary.

### Set the Control Throws

Use a ruler to accurately measure and set the control throw of each control surface as indicated in the chart that follows. If your radio does not have dual rates, we recommend setting the throws at the low rate settings. **Note:** The throws are measured at the **widest part** of the elevators, rudder and ailerons.

### These are the recommended control surface throws:

|                  | High Rate (3D)                         | Low Rate                               |
|------------------|--|--|
| <b>ELEVATOR:</b> | 5" [130mm] up<br>5" [130mm] down       | 1-3/4" [45mm] up<br>1-3/4" [45mm] down |
| <b>RUDDER:</b>   | 6" [150mm] right<br>6" [150mm] left    | 4" [100mm] right<br>4" [100mm] left    |
| <b>AILERONS:</b> | 2-3/4" [70mm] up<br>2-3/4" [70mm] down | 1-1/4" [32mm] up<br>1-1/4" [32mm] down |
| <b>FLAPS:</b>    | 4" [100mm] full                        | 2-3/4" [70mm] half                     |

**IMPORTANT:** The Giant U-CAN-DO 3D ARF has been **extensively** flown and tested to arrive at the throws at which it flies best. Flying your model at these throws will provide you with the greatest chance for successful first flights. If, after you have become accustomed to the way the Giant U-CAN-DO 3D ARF flies, you would like to change the throws to suit your taste, that is fine. However, too much control throw could make the model difficult to control, so remember, "more is not always better."

### Balance the Model (C.G.)

More than any other factor, the **C.G.** (balance point) can have the **greatest** effect on how a model flies, and may determine whether or not your first flight will be successful. If you value this model and wish to enjoy it for many flights, **DO NOT OVERLOOK THIS IMPORTANT PROCEDURE.** A model that is not properly balanced will be unstable and possibly unflyable.

At this stage the model should be in ready-to-fly condition with all of the systems in place including the engine, landing gear, covering and the radio system.

❑ 1. Use a felt-tip pen or 1/8" [3mm] wide tape to accurately mark the C.G. on the top of the wing. **The C.G. is located 6-1/4" [160mm] back from the leading edge of the wing.**

This is where your model should balance for the first flights. Later you may wish to experiment by shifting the C.G. up to 1/2" [13mm] forward or 1/2" [13mm] back to change the flying characteristics. Moving the C.G. forward may improve the smoothness and stability, but the model may then require more speed for take off and make it more difficult to slow for landing. Moving the C.G. aft makes the model more maneuverable, but could also cause it to become too difficult to control. In any case, **start at the recommended balance point** and do not at any time balance the model outside the specified range.

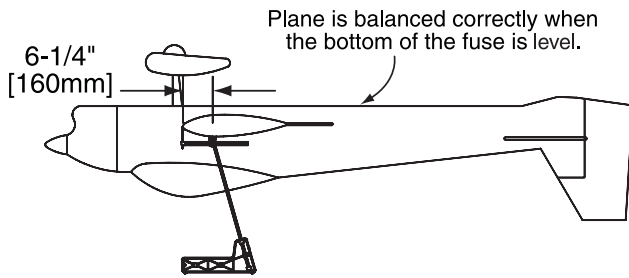

❑ 2. With the wing attached to the fuselage, all parts of the model installed (ready to fly) and an empty fuel tank, place the model upside-down on a Great Planes CG Machine, or lift it upside-down at the balance point you marked.

❑ 3. If the tail drops, the model is “tail heavy” and the battery pack and/or receiver must be shifted forward or weight must be added to the nose to balance. If the nose drops, the model is “nose heavy” and the battery pack and/or receiver must be shifted aft or weight must be added to the tail to balance. If possible, relocate the battery pack and receiver to minimize or eliminate any additional ballast required. If additional weight is required, nose weight may be easily added by using a “spinner weight” (GPMQ4645 for the 1 oz. weight, or GPMQ4646 for the 2 oz. weight). If spinner weight is not practical or is not enough, use Great Planes (GPMQ4485) “stick-on” lead. A good place to add stick-on nose weight is to the firewall (don’t attach weight to the cowl—it is not intended to support weight). Begin by placing incrementally increasing amounts of weight on the bottom of the fuse over the firewall until the model balances. Once you have determined the amount of weight required, it can be permanently attached. If required, tail weight may be added by cutting open the bottom of the fuse and gluing it permanently inside.

**Note:** Do not rely upon the adhesive on the back of the lead weight to permanently hold it in place. Over time, fuel and exhaust residue may soften the adhesive and cause the weight to fall off. Use #2 sheet metal screws, RTV silicone or epoxy to permanently hold the weight in place.

❑ 4. **IMPORTANT:** If you found it necessary to add any weight, recheck the C.G. after the weight has been installed.

### ***Balance the Model Laterally***

❑ 1. With the wing level, have an assistant help you lift the model by the engine propeller shaft and the bottom of the fuse under the TE of the fin. Do this several times.

❑ 2. If one wing always drops even a small amount when you lift the model, it means that side is heavy. Balance the airplane by adding weight to the other wing tip. An airplane that has been laterally balanced will track better in loops and other maneuvers.

## ***PREFLIGHT***

### ***Identify Your Model***

No matter if you fly at an AMA sanctioned R/C club site or if you fly somewhere on your own, you should always have your name, address, telephone number and AMA number on or inside your model. It is required at all AMA R/C club flying sites and AMA sanctioned flying events. Fill out the identification tag on the decal sheet and place it on or inside your model.

### ***Charge the Batteries***

Follow the battery charging instructions that came with your radio control system to charge the batteries. You should always charge your transmitter and receiver batteries the night before you go flying and at other times as recommended by the radio manufacturer.

**Note:** Checking the condition of your receiver battery pack is highly recommended. All battery packs, whether it’s a trusty pack you’ve just taken out of another model, or a new battery pack you just purchased, should be cycled, noting the discharge capacity. Often times, a weak battery pack can be identified (and a valuable model saved!) by comparing its actual capacity to its rated capacity. Refer to the instructions and recommendations that come with your cyclor. If you don’t own a battery cyclor, perhaps you can have a friend cycle your pack and note the capacity for you.

### ***Balance the Propellers***

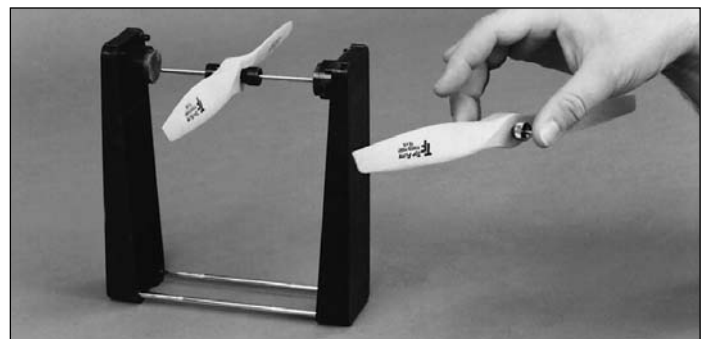

Carefully balance your propeller and spare propellers before you fly. An unbalanced prop can be the single most significant cause of vibration that can damage your model. Not only will engine mounting screws and bolts loosen, possibly with disastrous effect, but vibration may also damage your radio receiver and battery. Vibration can also cause your fuel to foam, which will, in turn, cause your engine to run hot or quit. We keep a Great Planes Fingertip Prop Balancer (GPMQ5000) in our flight box.

## Ground Check

If the engine is new, follow the engine manufacturer's instructions to break-in the engine. After break-in, confirm that the engine idles reliably, transitions smoothly and rapidly to full power and maintains full power—indefinitely. After you run the engine on the model, inspect the model closely to make sure all screws remained tight, the hinges are secure, the prop is secure and all pushrods and connectors are secure.

## Range Check

Ground check the operational range of your radio before the first flight of the day. With the transmitter antenna collapsed and the receiver and transmitter on, you should be able to walk at least 100 feet away from the model and still have control. Have an assistant stand by your model and, while you work the controls, tell you what the control surfaces are doing. Repeat this test with the engine running at various speeds with an assistant holding the model, using hand signals to show you what is happening. If the control surfaces do not respond correctly, do not fly! Find and correct the problem first. Look for loose servo connections or broken wires, corroded wires on old servo connectors, poor solder joints in your battery pack or a defective cell, or a damaged receiver crystal from a previous crash.

## ENGINE SAFETY PRECAUTIONS

**Failure to follow these safety precautions may result in severe injury to yourself and others.**

Keep all engine fuel in a safe place, away from high heat, sparks or flames, as fuel is very flammable. Do not smoke near the engine or fuel; and remember that engine exhaust gives off a great deal of deadly carbon monoxide. Therefore, **do not run the engine in a closed room or garage.**

Get help from an experienced pilot when learning to operate engines.

Use safety glasses when starting or running engines.

Do not run the engine in an area of loose gravel or sand; the propeller may throw such material in your face or eyes.

Keep your face and body as well as all spectators away from the plane of rotation of the propeller as you start and run the engine.

Keep these items away from the prop: loose clothing, shirt sleeves, ties, scarves, long hair or loose objects such as pencils or screwdrivers that may fall out of shirt or jacket pockets into the prop.

Use a "chicken stick" or electric starter to start the engine. Do not use your fingers to flip the propeller. Make certain the glow plug clip or connector is secure so that it will not pop off or otherwise get into the running propeller.

Make all engine adjustments from behind the rotating propeller.

The engine gets hot! Do not touch it during or right after operation. Make sure fuel lines are in good condition so fuel will not leak onto a hot engine, causing a fire.

To stop a glow engine, cut off the fuel supply by closing off the fuel line or following the engine manufacturer's recommendations. Do not use hands, fingers or any other body part to try to stop the engine. Do not throw anything into the propeller of a running engine.

## AMA SAFETY CODE (excerpts)

Read and abide by the following excerpts from the Academy of Model Aeronautics Safety Code. For the complete Safety Code refer to *Model Aviation* magazine, the AMA web site or the Code that came with your AMA license.

### General

1. I will not fly my model aircraft in sanctioned events, air shows, or model flying demonstrations until it has been proven to be airworthy by having been previously successfully flight tested.

2. I will not fly my model aircraft higher than approximately 400 feet within 3 miles of an airport without notifying the airport operator. I will give right of way to and avoid flying in the proximity of full-scale aircraft. Where necessary an observer shall be used to supervise flying to avoid having models fly in the proximity of full-scale aircraft.

3. Where established, I will abide by the safety rules for the flying site I use and I will not willfully and deliberately fly my models in a careless, reckless and/or dangerous manner.

7. I will not fly my model unless it is identified with my name and address or AMA number, on or in the model.

9. I will not operate models with pyrotechnics (any device that explodes, burns, or propels a projectile of any kind).

### Radio Control

1. I will have completed a successful radio equipment ground check before the first flight of a new or repaired model.

2. I will not fly my model aircraft in the presence of spectators until I become a qualified flier, unless assisted by an experienced helper.

3. I will perform my initial turn after take off away from the pit or spectator areas and I will not thereafter fly over pit or spectator areas, unless beyond my control.

4. I will operate my model using only radio control frequencies currently allowed by the Federal Communications Commission.

## CHECK LIST

- 1. Fuelproof all areas exposed to fuel or exhaust residue such as the wing saddle area, etc.
- 2. Check the C.G. according to the measurements provided in the manual.
- 3. Be certain the battery and receiver are securely mounted in the fuse. Simply stuffing them into place with foam rubber is not sufficient.
- 4. Extend your receiver antenna and make sure it has a strain relief inside the fuselage to keep tension off the solder joint inside the receiver.
- 5. Balance your model *laterally* as explained in the instructions.
- 6. Use thread-locking compound to secure critical fasteners such as the set screws that hold the wheel axles to the screws that hold the carburetor arm (if applicable), screw-lock pushrod connectors, etc.
- 7. Add a drop of oil to the axles so the wheels will turn freely.
- 8. Make sure all hinges are **securely** glued in place.
- 9. Reinforce holes for wood screws with thin CA where appropriate (servo mounting screws, cowl mounting screws, etc.).
- 10. Confirm that all controls operate in the correct direction and the throws are set up according to the manual.
- 11. Make sure there are silicone retainers on all the clevises and that all servo arms are secured to the servos with the screws included with your radio.
- 12. Secure connections between servo wires and Y-connectors or servo extensions and the connection between your battery pack and the on/off switch with vinyl tape, heat-shrink tubing or special clips suitable for that purpose.
- 13. Make sure any servo extension cords you may have used do not interfere with other systems (servo arms, pushrods, etc.).
- 14. Secure the pressure tap (if used) to the muffler with high temp RTV silicone, thread-locking compound or J.B. Weld.
- 15. Make sure the fuel lines are connected and are not kinked.
- 16. Balance your propeller (and spare propellers).
- 17. Tighten the propeller nut and spinner.
- 18. Place your name, address, AMA number and telephone number on or inside your model.
- 19. Cycle your receiver battery pack (if necessary) and make sure it is fully charged.
- 20. If you wish to photograph your model, do so before your first flight.
- 21. Range check your radio when you get to the flying field.

## FLYING

The Giant U-CAN-DO 3D ARF is a great-flying model that flies smoothly and predictably. The Giant U-CAN-DO 3D ARF does not, however, possess the self-recovery characteristics of a primary R/C trainer and should be flown only by experienced R/C pilots.

Whether you are looking to practice new 3D maneuvers and don't want to risk your competition aircraft, or are just starting to learn the most basic aerobatics, the Giant U-CAN-DO 3D ARF is a great choice. Regardless of your skill level, be sure your first flight begins with low rates (yes, even in a crosswind) and that you gradually expand your flight envelope, adding one new maneuver at a time.

Take offs, landings and most of your normal flights should be flown on low rates. (If your radio does not have dual rates, be sure to set the model up on the low rates provided.) **The high rates on this model are meant ONLY for use when doing 3D aerobatics – maneuvers performed while the model is flying slower than its normal stall speed.** That includes maneuvers as simple as a stall turn, or as complex as harrier rolls.

Don't get spoiled by how incredibly well the Giant U-CAN-DO 3D ARF hangs and torque rolls! Most models take an enormous amount of work to keep the model stationary in a hanger, but the unique design of Giant U-CAN-DO 3D ARF helps lock it solid in position and torque roll and hang with relative ease.

## Important Reminders

This is a high-performance 3D aerobatic aircraft. It is not designed for, and cannot withstand, high speeds. Please know that we have tested this model VERY extensively, with literally over 100 flights across numerous test models with a huge range of power plants.

### FOR YOUR SAFETY AND THE SAFETY OF YOUR MODEL, PLEASE:

1. **DO NOT** exceed the engine recommendations of 1.60 cu in [26.0cc] glow or 2.5 cu in [41.0cc] gas.
2. **DO NOT** exceed the maximum pitch for your propeller of 8" (i.e. 18x6 not 16x10).
3. **DO NOT** fly the model at full throttle, except on climbs of at least 10 degrees (no straight and level and no wide open dives).
4. **DO NOT** allow the model's tail surfaces to be hit, pushed, pressed upon or otherwise damaged during handling or during extreme flight maneuvers.

## Fuel Mixture Adjustments

A fully cowled engine may run at a higher temperature than an un-cowled engine. For this reason, the fuel mixture

should be richened so the engine runs at about 200 RPM below peak speed. By running the engine slightly rich, you will help prevent dead-stick landings caused by overheating.

**CAUTION (THIS APPLIES TO ALL R/C AIRPLANES):** If, while flying, you notice an alarming or unusual sound such as a low-pitched “buzz,” this may indicate control surface flutter. Flutter occurs when a control surface (such as an aileron or elevator) or a flying surface (such as a wing or stab) rapidly vibrates up and down (thus causing the noise). In extreme cases, if not detected immediately, flutter can actually cause the control surface to detach or the flying surface to fail, thus causing loss of control followed by an impending crash. The best thing to do when flutter is detected is to slow the model **immediately** by reducing power, then land as soon as safely possible. Identify which surface fluttered (so the problem may be resolved) by checking all the servo grommets for deterioration or signs of vibration. Make certain all pushrod linkages are secure and free of play. If it fluttered once, under similar circumstances it will probably flutter again unless the problem is fixed. Some things which can cause flutter are; Excessive hinge gap; Not mounting control horns solidly; Poor fit of clevis pin in horn; Side-play of wire pushrods caused by large bends; Excessive free play in servo gears; Insecure servo mounting; and one of the most prevalent causes of flutter; Flying an over-powered model at excessive speeds.

## Take Off

Before you get ready to take off, see how the model handles on the ground by doing a few practice runs at **low speeds** on the runway. Hold “up” elevator to keep the tailwheel on the ground. If necessary, adjust the tailwheel so the model will roll straight down the runway. If you need to calm your nerves before the maiden flight, shut the engine down and bring the model back into the pits. Top off the fuel, then check all fasteners and control linkages for peace of mind.

Remember to take off into the wind. When you’re ready, point the model straight down the runway, hold a bit of up elevator to keep the tail on the ground to maintain tailwheel steering, then gradually advance the throttle. As the model gains speed decrease up elevator, allowing the tail to come off the ground. One of the most important things to remember with a taildragger is to always be ready to apply **right** rudder to counteract engine torque. Gain as much speed as your runway and flying site will practically allow before gently applying up elevator, lifting the model into the air. At this moment it is likely that you will need to apply more right rudder to counteract engine torque. Be smooth on the elevator stick, allowing the model to establish a **gentle** climb to a safe altitude before turning into the traffic pattern.

## Flight

For reassurance and to keep an eye on other traffic, it is a good idea to have an assistant on the flight line with you. Tell him to remind you to throttle back once the plane gets to a

comfortable altitude. While full throttle is usually desirable for take off, most models fly more smoothly at reduced speeds.

Take it easy with the Giant U-CAN-DO 3D ARF for the first few flights, gradually getting acquainted with it as you gain confidence. Adjust the trims to maintain straight and level flight. After flying around for a while and while still at a safe altitude with plenty of fuel, practice slow flight and execute practice landing approaches by reducing the throttle to see how the model handles at slower speeds. Add power to see how she climbs as well. Continue to fly around, executing various maneuvers and making mental notes (or having your assistant write them down) of what trim or C.G. changes may be required to fine tune the model so it flies the way you like. Mind your fuel level, but use this first flight to become familiar with your model before landing.

## Landing

To initiate a landing approach, lower the throttle while on the downwind leg. Allow the nose of the model to pitch downward to gradually bleed off altitude. Continue to lose altitude, but maintain airspeed by keeping the nose down as you turn onto the crosswind leg. Make your final turn toward the runway (into the wind) keeping the nose down to maintain airspeed and control. Level the attitude when the model reaches the runway threshold, modulating the throttle as necessary to maintain your glide path and airspeed. If you are going to overshoot, smoothly advance the throttle (always ready on the right rudder to counteract torque) and climb out to make another attempt. When you’re ready to make your landing flare and the model is a foot or so off the deck, smoothly increase up elevator until it gently touches down. Once the model is on the runway and has lost flying speed, hold up elevator to place the tail on the ground, regaining tailwheel control.

One final note about flying your model. Have a goal or flight plan in mind for **every** flight. This can be learning a new maneuver(s), improving a maneuver(s) you already know, or learning how the model behaves in certain conditions (such as on high or low rates). This is not necessarily to improve your skills (*though it is never a bad idea!*), but more importantly so you do not surprise yourself by impulsively attempting a maneuver and suddenly finding that you’ve run out of time, altitude or airspeed. Every maneuver should be deliberate, not impulsive. For example, if you’re going to do a loop, check your altitude, mind the wind direction (anticipating rudder corrections that will be required to maintain heading), remember to throttle back at the top and make certain you are on the desired rates (high/low rates). A flight plan greatly reduces the chances of crashing your model just because of poor planning and impulsive moves. **Remember to think. Have a ball! But always stay in control and fly in a safe manner.**

**GOOD LUCK AND GREAT FLYING!**

