

.40-SIZE SPORT SCALE ALMOST READY-TO-FLY MODEL

Cessna 182

SKYLANE™

WITH ALL WOOD CONSTRUCTION

ARF

Cessna is a registered trademark of Cessna Aircraft Company

INSTRUCTION MANUAL



Wing Span - 62-5/8 in
Wing Area - 577 sq in
Weight - 6 lbs
Wing Loading - 24 oz/sq in
Fuse Length - 47 in
Engine - .40 - .46 2-stroke, .52 4-stroke

WARRANTY

Great Planes® Model Manufacturing Co. guarantees this kit to be free from defects in both material and workmanship at the date of purchase. This warranty does not cover any component parts damaged by use or modification. **In no case shall Great Planes' liability exceed the original cost of the purchased kit.** Further, Great Planes reserves the right to change or modify this warranty without notice.

In that Great Planes has no control over the final assembly or material used for final assembly, no liability shall be assumed nor accepted for any damage resulting from the use by the user of the final user-assembled product. By the act of using the user-assembled product, the user accepts all resulting liability.

If the buyer is not prepared to accept the liability associated with the use of this product, the buyer is advised to return this kit immediately in new and unused condition to the place of purchase.

While this kit has been flight tested to exceed normal use, if the plane will be used for extremely high stress flying, such as racing, the modeler is responsible for taking steps to reinforce the high stress points.

READ THROUGH THIS MANUAL BEFORE STARTING CONSTRUCTION. IT CONTAINS IMPORTANT WARNINGS AND INSTRUCTIONS CONCERNING THE ASSEMBLY AND USE OF THIS MODEL.



P.O. Box 788 Urbana, IL 61803 (217) 398-8970

TABLE OF CONTENTS

Important Safety Precaution	2
Introduction	2
Precautions	2
Decisions You Must Make	3
Engine Selection.....	3
Preparations	3
Required Accessories.....	3
Building Supplies and Tools.....	3
Optional Supplies and Tools.....	3
General Inspection.....	4
Building Notes.....	4
Metric Conversions/Ruler.....	4
Parts List.....	5
Wing Assembly	6
Wing Installation	7
Install the Tail Components	7
Engine Installation	9
Landing Gear Installation	10
Radio Installation	11
Aileron Servo Installation.....	14
Steering Pushrod Installation.....	16
Throttle Pushrod Installation.....	17
Fuel Tank Installation	17
Cowl Installation	19
Window Installation	19
Final Assembly	20
Radio System Set-Up	21
Check the Control Directions.....	21
Adjust the Control Throws.....	21
Route the Receiver Antenna.....	22
Balance Your Model	22
Check the Lateral Balance.....	22
Check the Fore-Aft Balance.....	22
Preparing to Fly Your Cessna 182	23
Charge the Batteries.....	23
Balance the Propeller.....	23
Find a Safe Place to Fly.....	23
Ground Check the Model.....	23
Range Check Your Radio.....	23
Engine Safety Precautions.....	24
AMA Safety Code (excerpt)	24
General.....	24
Radio Control.....	24
Flying Your Cessna 182	24
Takeoff.....	24
Flying.....	25
Landing.....	25
Engine Mount Template	Back Cover Page
Cowl Opening Template	Back Cover Page

**PROTECT YOUR MODEL, YOURSELF
& OTHERS...FOLLOW THIS
IMPORTANT SAFETY PRECAUTION**

Your Cessna 182 ARF is not a toy, but rather a sophisticated, working model that functions very much like a full-size airplane. Because of its realistic performance, the Cessna 182 ARF, if not assembled and operated correctly, could possibly cause injury to yourself or spectators and damage property.

To make your R/C modeling experience totally enjoyable, we recommend that you get experienced, knowledgeable help from an instructor with assembly and during your first flights. You'll learn faster and avoid risking your model before you're truly ready to solo. Your local hobby shop has information about flying clubs in your area whose membership includes qualified instructors.

You can also contact the national Academy of Model Aeronautics (AMA), which has more than 2,500 chartered clubs across the country. Through any one of them, instructor training programs and insured newcomer training are available. Contact the AMA at the address or toll-free phone number below:



Academy of Model Aeronautics

5151 East Memorial Drive
Muncie, IN 47302-9252
Tele. (800) 435-9262
Fax (765) 741-0057

Or via the Internet at: <http://www.modelaircraft.org>

INTRODUCTION

The Great Planes **Cessna 182 ARF** is a high performance sport airplane that closely resembles the full-size Cessna 182 both in appearance and performance. The Cessna 182 ARF is very stable and predictable, allowing even low time pilots to enjoy it.

This is not a beginner's airplane! While the **Cessna 182 ARF** is easy to build and flies great, we must discourage you from selecting this kit as your first R/C airplane. It lacks the self-recovery characteristics of good basic trainers such as the Great Planes **PT™ Series**. On the other hand, if you have already learned the basics of R/C flying, and you are able to safely handle a .40-size scale airplane, the **Cessna 182 ARF** is an excellent choice to try your skills at flying a sport scale airplane.

PRECAUTIONS

1. You must assemble the model according to the instructions. Do not alter or modify the model, as doing so may result in an unsafe or unflyable model. In a few cases the instructions may differ slightly from the photos. In those instances the written instructions should be considered as correct.
2. Take time to build straight, true and strong.
3. Use an R/C radio system that is in first-class condition, and a correctly sized engine and components (fuel tank, wheels, etc.) throughout your building process.
4. You must properly install the R/C radio system and other components so that the model operates properly on the ground and in the air.

5. You must test the operation of the model before every flight to insure that all equipment is operating and you must make certain that the model has remained structurally sound. Be sure to check clevises or other connectors often and replace them if they show signs of wear or fatigue.

Note: We, as the kit manufacturer, provide you with a top quality kit and great instructions, but ultimately the quality of your finished model depends on how you build it; therefore, we cannot in any way guarantee the performance of your completed model, and no representations are expressed or implied as to the performance or safety of your completed model.

Remember: Take your time and follow directions to end up with a well-built model that is straight and true. Please inspect all parts carefully before starting to build!

YOU CAN CONTACT US...

If any parts are missing, broken or defective, or if you have any questions about building or flying this airplane, please call us at (217) 398-8970. You can also check our web site at www.greatplanes.com for the latest Cessna 182 ARF updates, or e-mail your questions to:

productsupport@greatplanes.com

If you are calling for replacement parts, please reference the part numbers and have them ready when calling.

DECISIONS YOU MUST MAKE

Engine Selection

There are several engines that will work well in your Cessna 182 ARF. We recommend a 2-stroke such as an **O.S.® .40 LA**, **O.S.® .40 FX**, **O.S.® .46 FX**, or the **SuperTigre® GS-40** or **GS-45**. For unsurpassed power and realistic sound, an **O.S.® FS-52** 4-stroke can't be beat.

PREPARATIONS

Required Accessories

Items in parentheses such as (GPMQ4243) are suggested part numbers recognized by distributors and hobby shops and are listed for your ordering convenience. **GPM** is the Great Planes brand, **TOP** is the Top Flite® brand, and **HCA** is the Hobbico® brand.

- Four-channel Radio With Five Servos
- Engine - See **Engine Selection** Above
- Propeller (Top Flite® Power Point®—Refer To Your Engine's Instructions For Proper Size)
- Medium Fuel Tubing (GPMQ4131)
- 6" Servo Extension (2)
- "Y" connector (1)

Building Supplies & Tools

These are the building tools that are required. We recommend **Great Planes Pro™ CA and Epoxy glue**.

- 2 oz. Pro CA (Thin, GPMR6003)
- 2 oz. Pro CA+ (Medium, GPMR6009)
- 6-Minute Pro Epoxy (GPMR6045)
- 30-Minute Pro Epoxy (GPMR6047)
- Epoxy Brushes (GPMR8060)
- Pro Thread Locking Compound (GPMR6060)
- T-pins (HCAR5150)
- Adjustable Wrench
- Plastic Wrap or Waxed Paper
- Isopropyl Alcohol (70%)
- Mixing Sticks (GPMR8055)
- Round Toothpicks
- Hobby Knife (TOWR1010), #11 Blades (TOWR1015)
- Small Hobby Clamps
- String
- Builders Triangle Set (HCAR0480)
- Masking Tape (TOPR8018)
- Sandpaper (coarse, medium, fine grit)
- Easy-Touch™ Bar Sander (GPMR6170, or similar)
- 1/4" Latex Foam Rubber Padding (HCAQ1000)
- Paper Towels
- Felt-Tip Marker
- Wire Cutter
- Pliers
- Long Nose Pliers
- File
- Drill Bits: 1/16" [1.5mm], 5/64" [2mm], 3/32" [2.5mm], 1/8" [3mm], 5/32" [4mm], 3/16" [5mm], 1/4" [6mm], 1/2" [13mm]

Optional Supplies & Tools

- R/C-56 Canopy Glue
- CA Applicator Tips (HCAR3780)
- CA Debonder (GPMR6039)
- Sealing Iron (TOPR2100)
- Heat Gun (TOPR2000)
- Single-edge Razor Blades (HCAR0312)
- Curved Tip Canopy Scissors for Trimming Plastic Parts (HCAR0667)
- Switch and Charge Jack (GPM1000)
- Center Punch
- Hook and Loop Material (GPMQ4480)
- Dead Center™ Engine Mount Hole Locator (GPMR8130)
- Fuel Filler Valve (GPMQ4160)

General Inspection

Remove the fuselage, wing panels, rudder assembly and stabilizer assembly from their bags. Inspect all items closely to check for any damage. If any of the control surfaces are attached, simply pull them apart and store the hinges in a safe place until it is time to re-attach them. The manual begins with all the surfaces shown separated.

Your Cessna 182 is covered with high quality Top Flite MonoKote® covering. If any of the covering has loosened, use a heat gun or sealing iron to correct any of these problems.

Building Notes

Several times during construction we refer to the "top" or "bottom" of the model or a part of the model. It is understood that the "top" or "bottom" of the model is as it would be when the airplane is right side up and will be referred to as the "top" even if the model is being worked on upside-down.

Metric Conversions

$1/64" = .4\text{mm}$	$3/16" = 4.8\text{mm}$	$1" = 25.4\text{mm}$	$18" = 457.2\text{mm}$
$1/32" = .8\text{mm}$	$1/4" = 6.4\text{mm}$	$2" = 50.8\text{mm}$	$21" = 533.4\text{mm}$
$1/16" = 1.6\text{mm}$	$3/8" = 9.5\text{mm}$	$3" = 76.2\text{mm}$	$24" = 609.6\text{mm}$
$3/32" = 2.4\text{mm}$	$1/2" = 12.7\text{mm}$	$6" = 152.4\text{mm}$	$30" = 762\text{mm}$
$1/8" = 3.2\text{mm}$	$5/8" = 15.9\text{mm}$	$12" = 304.8\text{mm}$	$36" = 914.4\text{mm}$
$5/32" = 4\text{mm}$	$3/4" = 19\text{mm}$	$15" = 381\text{mm}$	

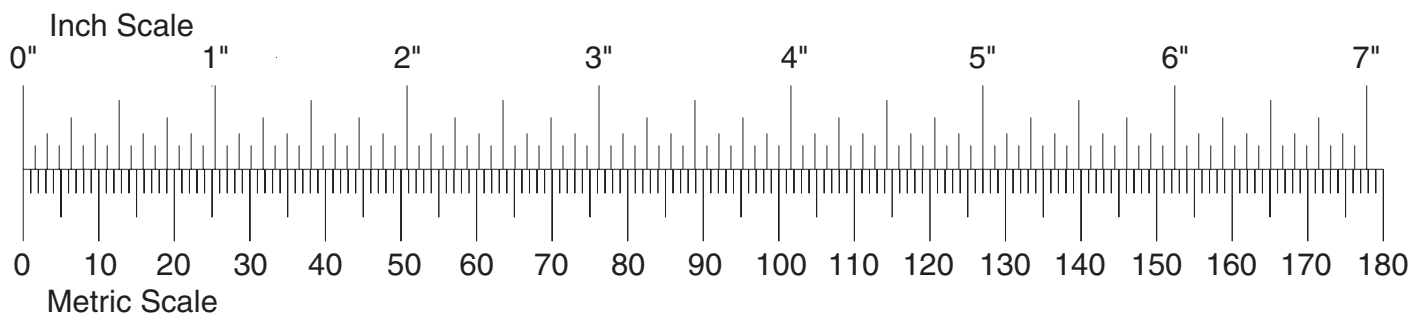

Parts List

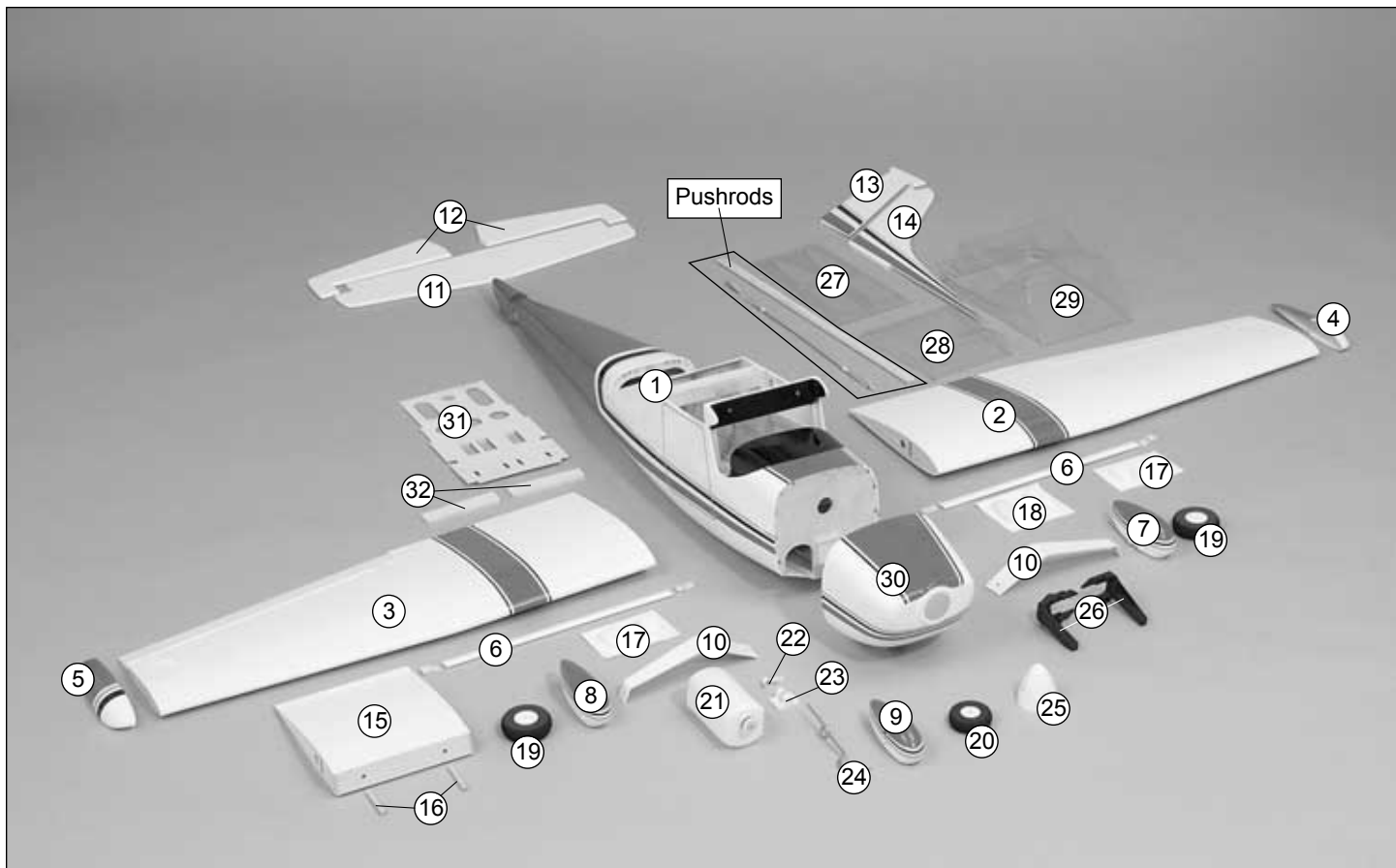

Key#	Description	Qty
1	Fuselage	1
2	Left Wing Panel w/Aileron	1
3	Right Wing Panel w/Aileron	1
4	Left Wing Tip	1
5	Right Wing Tip	1
6	Wing Strut (Left & Right)	2
7	Left Wheel Pant	1
8	Right Wheel Pant	1
9	Nose Gear Wheel Pant	2
10	Aluminum Landing Gear (Right & Left)	2
11	Stabilizer	1
12	Elevator Assembly (Right & Left)	2
13	Rudder	1
14	Vertical Fin	1
15	Wing Center-Section	1
16	Wing Dowels	2
17	Wing Strut Fairing (Left & Right)	2
18	Landing Gear Fairing	1
19	Main Wheels	2
20	Nose Wheel	1
21	Fuel Tank	1
22	Steering Arm	1
23	Nose Gear Mount	1
24	Nose Gear	1
25	Spinner	1
26	Adjustable Engine Mount (Left & Right Halves)	2

27	Side Windows (Left & Right)	2
28	Rear Window	1
29	Front Window	1
30	Cowl	1
31	Servo Tray	1
32	Wing Joiners	2

Parts Not Shown In Photo

Description	Qty
CA Hinge Strip (2" x 9")	1
Hardware Bag	1

Replacement Parts

If needed, replacement parts for your Cessna 182 ARF are available through your hobby supplier.

Wing Kit.....	GPMA2070
Fuselage Kit	GPMA2071
Tail Set	GPMA2072
Cowl	GPMA2073
Windows.....	GPMA2074
Landing Gear Set.....	GPMA2075
Wheel Pants.....	GPMA2076
Strut Set	GPMA2077
Wing Tips.....	GPMA2078

WING ASSEMBLY

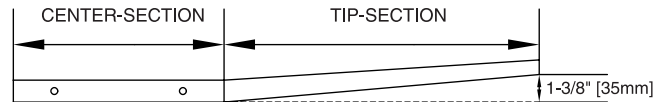
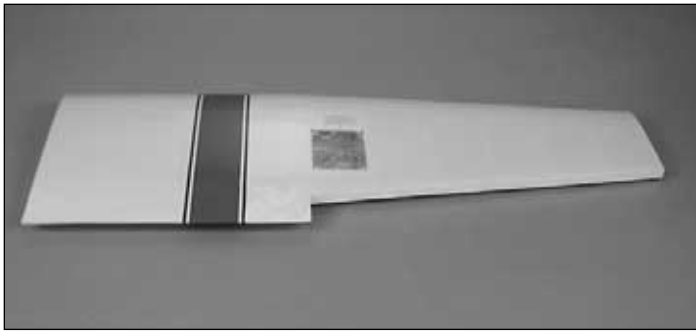

Make a dry run of the following step without using any glue so you will know how to join your wing together, then proceed using glue.

❑ 1. Mark the ailerons left and right and remove them from the wing panels. Remove the covering from the **aileron servo openings** on the bottom of the wing only. Cut 1/8" [3mm] inside of the opening to allow some material to be ironed down inside the opening. Use a sealing iron to secure the covering around the openings.

❑ 2. Locate the pre-installed strings in the **wing center-section** and **wing outer panels**. When attaching the wing outer panels to the wing center-section, the strings for installing the aileron servos must be moved so they do not interfere with the fit of the panels. Don't remove the string because you will use it to pull your aileron servo cords through the wing later. Tape each of the strings located in the aileron servo openings in the outer tip panels to the bottom of the wing.

❑ 3. Locate the hardwood wing joiners. Test fit the wing joiner into the right wing panel and the right side of the wing center-section. The joiner is positioned so 1/3 is in the wing center-section, and 2/3 is in the tip panel. A snug fit of the joiner is desirable. If the joiner does not fit properly, lightly sand any uneven surfaces of the joiner edges and sides. Repeat this step to check the fit of the other wing joiner in the left wing panel. Label each wing joiner for orientation and the side that it is to be used on.

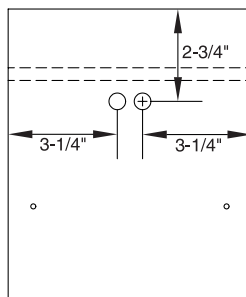

❑ 4. Drill two 1/2" [13mm] holes in the **BOTTOM** of the wing center-section as shown in the drawing. The servo leads will exit from these holes. The holes are located 2-3/4" [70mm] back from the front of the wing center-section and 3-1/4" [83mm] from the edges.

❑ 5. Un-tape the pre-installed strings in the wing center-section and the right wing outer panel. Tie the strings together, being careful not to pull the strings out of the panels. **Note:** Don't remove the strings because you will use them to pull your aileron servo cords through the wing later. Tape a piece of wax paper or plan protector over your work surface. Use a liberal amount of 30-minute epoxy to glue the wing joiner into the right wing panel and wing center-section. Apply epoxy to all sides of the joiner, joiner pockets, and center ribs of both the right wing panel and wing center-section. Join the wing panel and wing center-section. Use masking tape to tightly tape the right wing panel and wing center-section together. Be certain the leading and trailing edges align. If you have used enough epoxy, it will "ooze" out from the joint between the two ribs. Wipe off any excess epoxy from the outside of the wing with a paper towel and rubbing alcohol. With the wing center-section upright and flat on your building surface, measure the distance from your work surface to the tip of the wing outer panel to make sure you have the correct amount of dihedral as shown in the sketch. After the epoxy has cured, repeat this step to join the left wing panel to the wing center-section.

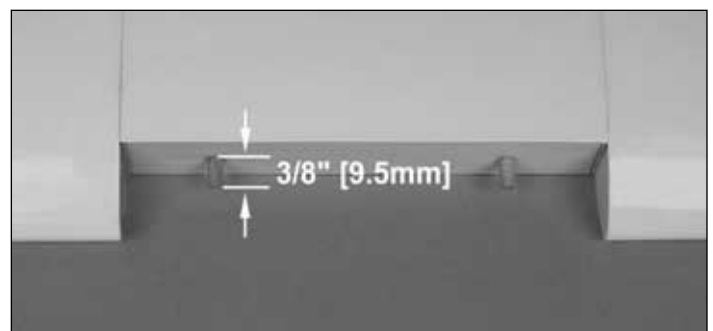

❑ 6. Locate the two 1/4" x 2-1/8" [6mm x 54mm] hardwood **wing dowels**. Slightly bevel the ends of the dowels. Test fit the dowels into the wing, making sure they lock into the holes inside the wing. If necessary, clean out the holes in the wing using a 1/4" [6mm] drill bit. Use 30-minute epoxy to glue the dowels into the wing, letting them protrude 3/8" [9.5mm]. Wipe off any excess epoxy using a paper towel and rubbing alcohol.

WING INSTALLATION

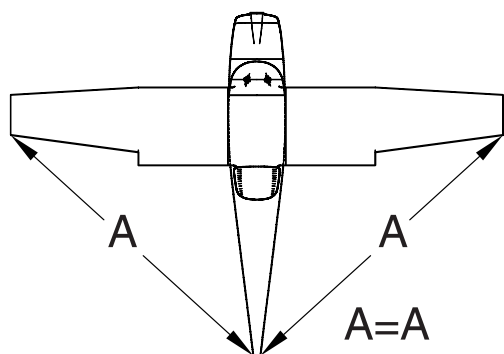

❑ 1. After the epoxy has cured from the previous step, place the wing on the **fuselage**. Measure from the aft center of the fuselage to one wing tip and record the distance. Measure from the same point to the opposite wing tip, and compare it to the first measurement. If the measurements are not the same, adjust the wing and re-measure until they are equal. Place a mark on the wing and fuselage so it can be repositioned accurately for the following steps.

❑ 2. Remove the covering from the wing center-section where the wing bolts will pass through the wing.

❑ 3. Bolt the wing to the fuselage using two 6-32 x 1-1/4" **machine screws** and two 6-32 **washers**. Check the alignment of the wing and enlarge the holes in the wing slightly to allow the wing to be shifted to match the alignment marks.

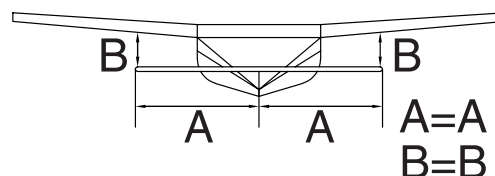

❑ 2. Mount the wing to the fuselage using the bolts. Stand back 8 to 10 feet [2.5 to 3 meters] and view the model from the front and rear. The stabilizer tips should be equally spaced above the level of the wing. If not, lightly sand the high side of the stab saddle to correct the problem. Work slowly and check the alignment often.



❑ 3. When the alignment is correct, mark the outline of the fuselage onto the bottom and top of the stabilizer. Remove the stabilizer, and trim the covering 1/32" [.8mm] inside of the lines, being careful not to cut into the underlying wood. Slide the stabilizer back into the fuselage, re-check the alignment, and wick thin CA along the joint between the stabilizer and fuselage.

INSTALL THE TAIL COMPONENTS

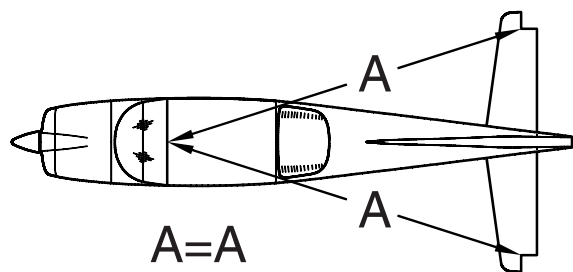

❑ 1. Remove the covering from the slot in the fuselage for the **horizontal stabilizer**. The location for the stabilizer can be located by gently pressing the covering using your index finger along the sides of the fuselage. Slide the stabilizer into position, and check the alignment as shown in the sketch.

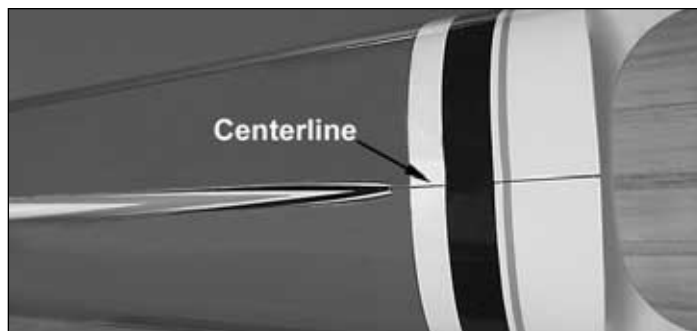
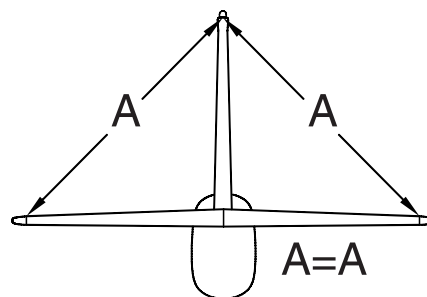

❑ 4. Remove the covering on the fuselage under the **vertical fin**. Draw a centerline on the top of the fuselage for use in aligning the fin. Slide the fin into position, and check the alignment as shown in the sketch and photo. Draw a line

along both the sides of the fin where it meets the fuselage and remove the covering 1/32" [.8mm] inside the line, being careful not to cut into the underlying wood. Sand the bottom of the fin and the slot in the fuselage if the fin is out of alignment. Do not force the forward section of the fin into position, as this will result in poor flight characteristics. Use 30-minute epoxy to glue the fin in position. Work the epoxy into the slot in the fuselage, filling any loose-fitting joints between the fuselage and stabilizer. Check the alignment of the fin to the stabilizer with a triangle, then secure it in position with masking tape until the epoxy has cured. Double-check the alignment of the fin with the stabilizer while the epoxy cures.

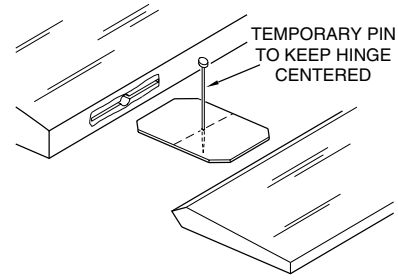

B. If the hinges don't remain centered, remove the rudder and insert a pin in the center of the hinges. Make sure there is approximately a 1/64" [.4mm] gap between the rudder and the fin.

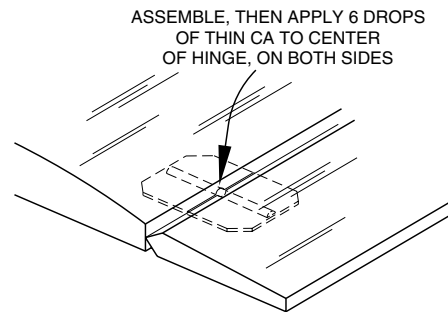
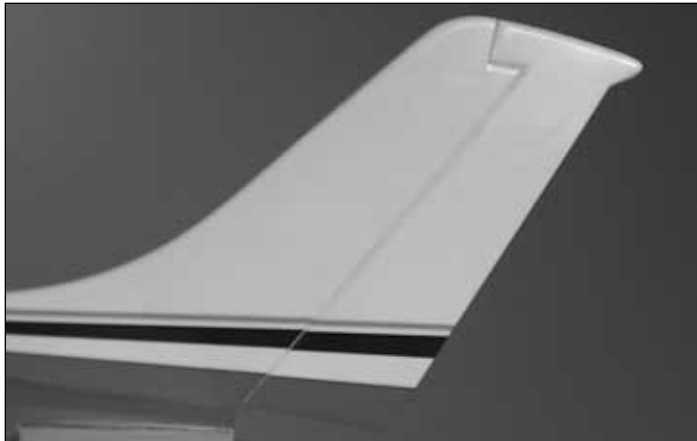

C. Add six drops of thin CA to the center of the hinges on both sides. Use a paper towel to absorb excess CA from the hinge gap before it cures. Do not use CA accelerator; allow the CA to cure slowly.

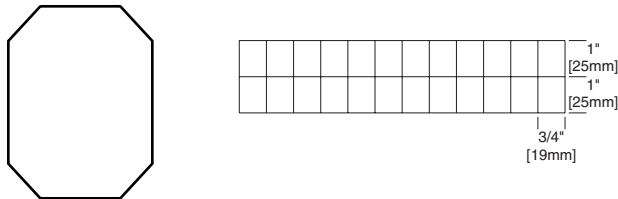

5. Test fit the rudder to the fin with the hinges. If the hinges are difficult to install or don't go in far enough, carefully enlarge the hinge slots with a hobby knife and a #11 blade. (Cut the hinges to the size shown above from the 2" x 9" [51mm x 229mm] hinge material.) Use the following procedure for gluing the hinges and tail gear assembly:

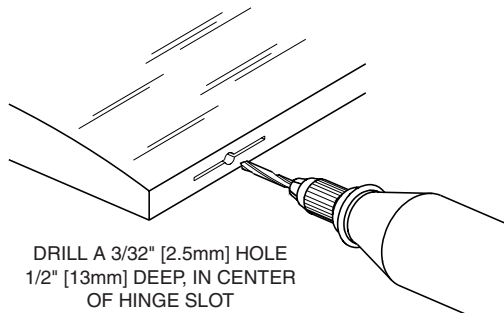

A. Drill a 3/32" [2.5mm] hole, 1/2" [13mm] deep, in the center of the hinge slot. If you use a Dremel® MultiPro™ for this task, it will result in a cleaner hole than if you use a slower speed drill. Drilling the hole will twist some of the wood fibers into the slot, making it difficult to insert the hinge, so you should reinsert the knife blade, working it back and forth a few times to clean out the slot.



6. Use the same hinging method to join the Elevators to the stab.

ENGINE INSTALLATION

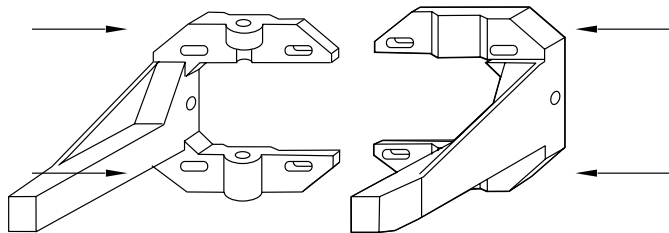
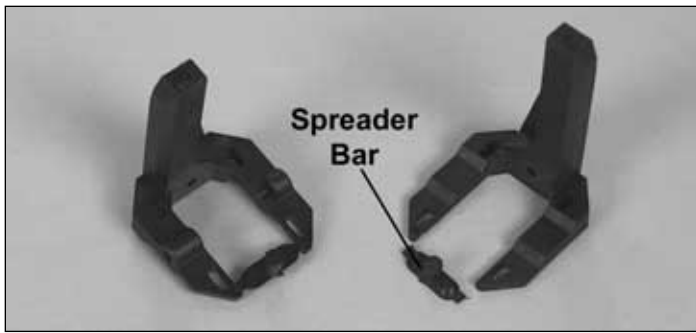

1. Cut or break the “spreader bar” from each **engine mount** half. Carefully trim any extra material left by the spreader bar from each mount half. The surfaces where the spreader bars were attached must be smooth to allow the mount halves to fit together. Trim the flashing off any rough edges if necessary.

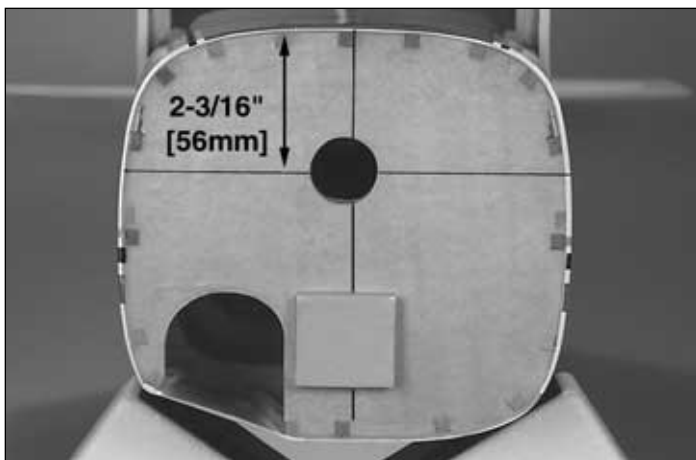

2. Draw a **horizontal** line on the firewall 2-3/16" [56mm] from the top of the fuselage. Draw a **vertical** line on the firewall along the left side of the top and bottom stringers as shown in the photo.

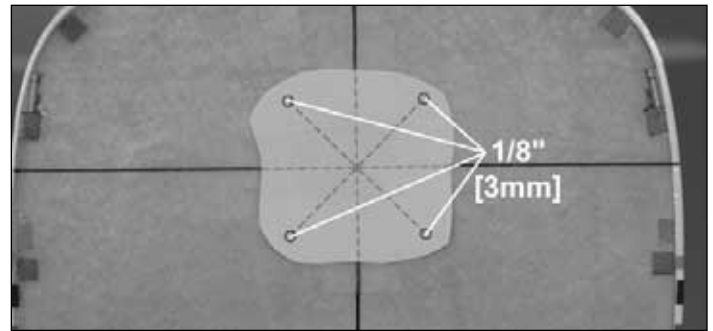

3. Cut the **engine mount template** from the back cover page and tape it to the firewall as shown above. At the locations on the template, drill four 1/8" [3mm] holes in the firewall for the engine mount blind nuts.



4. Install four 4-40 **blind nuts** to the inside of the firewall. Pull the blind nuts into the back side of the firewall using a 4-40 machine screw (with a flat washer under the head of the bolt). Fit the two halves of the engine mount together. Use four #4 **flat washers** and four 4-40 x 3/4" **machine screws** to secure the engine mount to the firewall. Do not tighten the screws at this time, as the mount must be adjusted for the engine.

5. Test fit your engine into the mount. Adjust the width of the rails to fit the engine snugly. Tighten the mount screws to allow marking the engine mounting holes without moving the rails.



6. Position the engine on the engine mount rails so the propeller thrust washer (or spinner backplate) is 4-7/8" [124mm] ahead of the firewall. Use a Great Planes Dead Center Hole Locator (GPMR8130) (not included) or a sharpened piece of wire to scribe the four engine mount holes onto the rails. Use a center punch on the marks to prevent the drill bit from wandering, then drill 3/32" [2.5mm] pilot holes through the rails. Be sure to hold the drill

perpendicular to the rails. If you have access to a drill press, this is a good tool for this purpose. Put a drop of oil into each hole. Use four #4 x 5/8" **sheet metal screws** to secure the engine to the mount.

the landing gear as shown. Use a felt tip marker and transfer the location of the hole onto the wheel pant. Remove the pant, and drill the location using a 5/32" [4mm] drill bit. Repeat the step for the other wheel pant.

LANDING GEAR INSTALLATION

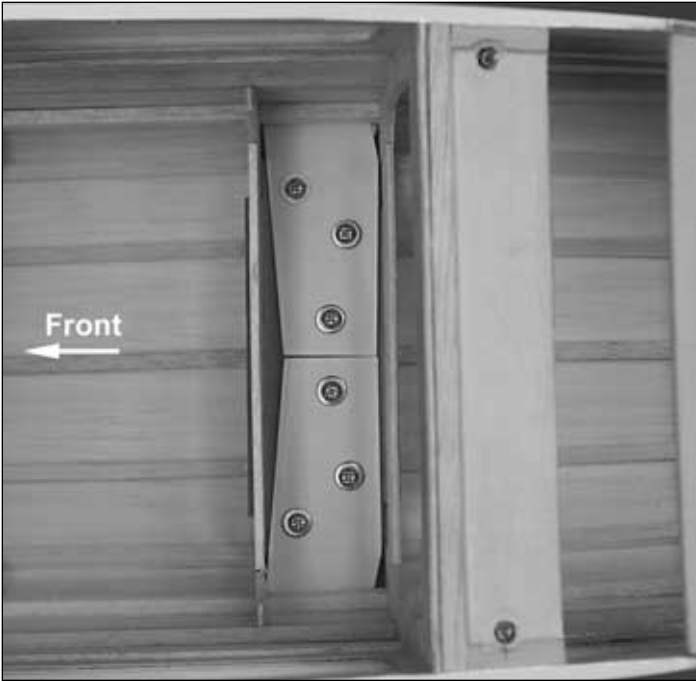

1. Test fit the **main landing gear** into the fuselage. The gear will be swept forward toward the front of the fuselage. Position the gear so they rest on top of the plywood gear support plate. Secure the location on the main gear using six 6-32 x 1/2" **machine screws** and six #6 **washers**. Use thread locking compound on the screws to prevent loosening.

2. Locate the two landing gear fairings. Cut the fairings out using a hobby knife and scissors. Test fit the fairings onto the landing gear and trim them for the best fit. Use the photos on the box as a guide in trimming the fairings. Attach the each fairing to the fuselage using medium CA.

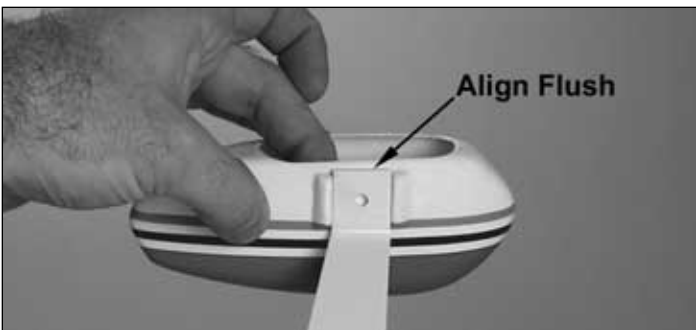

3. Position a **main wheel pant** onto the main gear. Align the pant so the bottom of the pant is flush with the bottom of

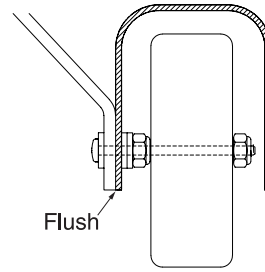

4. Place a #6 washer onto a 6-32 x 1-1/2" machine screw. Slide the screw through the landing gear. Place the wheel pant onto the screw, then place two #6 washers onto the screw. Begin threading a 6-32 **lock nut** onto the screw, but only thread the nut on until 1/4" [6mm] of the screw is exposed on the opposite side of the nut. Place the wheel onto the screw, then while holding onto the nut using pliers, tighten the screw to secure the wheel pant onto the landing gear. Secure the wheel using a 6-32 lock nut. The remaining nut can be tightened using either a hemostat or long nose pliers.

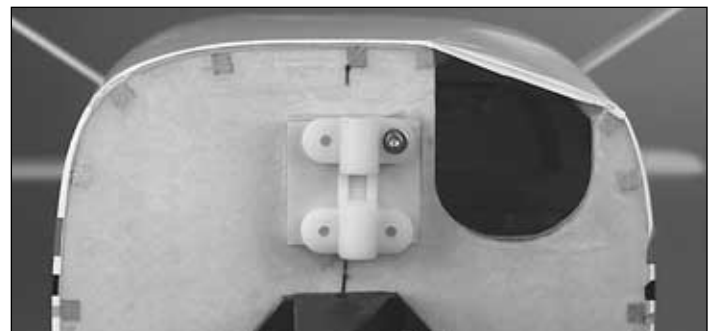

5. Center the nylon **nose gear block** on the nose gear block standoff. Mark the location for one of the holes. Drill the one location using an 1/8" [3mm] drill bit. Install one 4-40 blind nut to the inside of the firewall. Pull the blind nut into the back side of the firewall using a 4-40 socket head cap screw (with a flat washer under the head of the bolt). Use a #4 flat washer and a 4-40 x 1" **socket head cap screw** to temporarily attach the nose gear block to the standoff. Do not tighten the screw at this time, as the mount must be aligned using the nose gear wire.

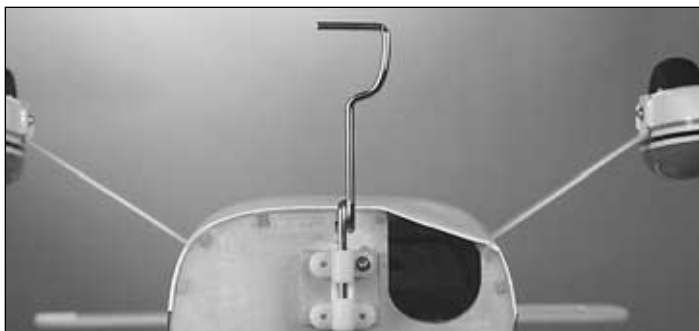

❑ 6. Locate the **nose gear wire** and slide it through the nose gear block. Adjust the position of the nose gear block until the nose gear wire is aligned with the centerline of the fuselage. Mark the locations for the remaining three holes for the nose gear block. Remove the block, and drill the locations using a 1/8" [3mm] drill bit. Secure the nose gear block using a total of four 4-40 blind nuts, four #4 washers and four 4-40 x 1" socket head cap screws.

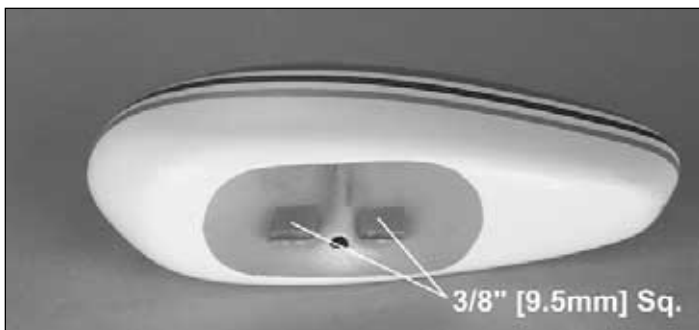

❑ 7. Prepare the **nose gear wheel pant** by gluing two 3/8" [9.5mm] square pieces of a mixing stick inside the pant as shown using 6-minute epoxy.

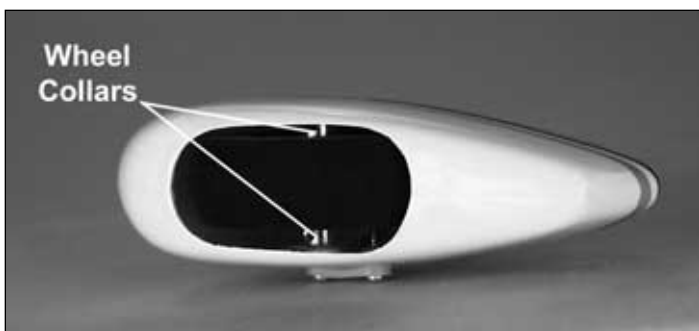

❑ 8. Install the nose wheel and wheel pant by sliding the wheel pant onto the nose gear wire. Slide a 5/32" **wheel collar** onto the wire, inside the wheel pant. This wheel collar is used as a spacer, and does not require a set screw to be installed. Next, slide the wheel onto the wire. Last, thread a 6-32 **set screw** into a 5/32" wheel collar and slide it onto the nose gear wire. With the wheel pant pressed against the nose gear wire, tighten the set screw.

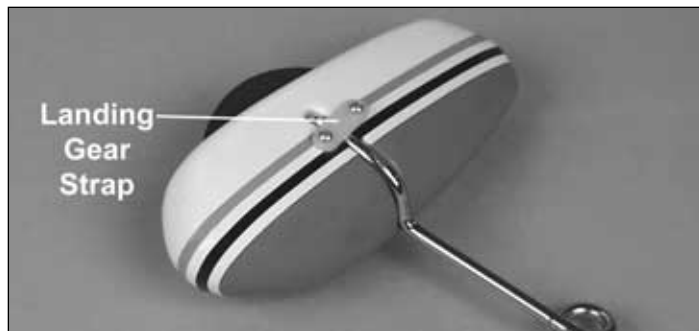

❑ 9. Position a nylon **landing gear strap** over the nose gear wire. Mark the locations for the two holes so they will be over the two pieces of the mixing stick which was glued inside the wheel pant. Drill two 1/16" [1.5mm] holes at the locations. Secure the strap into position using two #2 x 3/8" **sheet metal screws**.

RADIO INSTALLATION

❑ Remove the covering from the **windows** on both sides of the fuselage. Cut 1/8" [3mm] inside of the openings to allow some material to be ironed down inside the opening. Use a sealing iron to secure the covering around the opening.

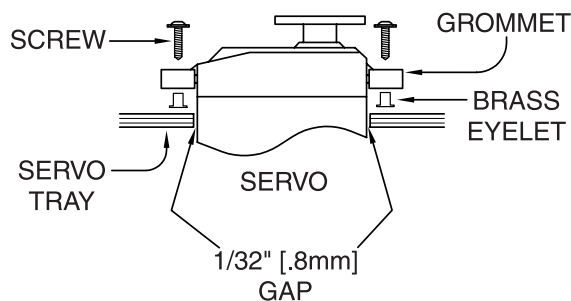

❑ 1. Use the following sequence for mounting the servos into the **servo tray**:

❑ A. Install rubber grommets and brass eyelets in the servos as shown in the provided sketch.

❑ B. Test fit the servos in the tray. Enlarge the openings if needed to create a 1/32" (.8mm) gap around the servo.

❑ C. Mark servo mounting hole locations on the tray, then drill 1/16" [1.5mm] pilot holes through each mark.

❑ D. Mount the servos with the screws provided with your radio system.

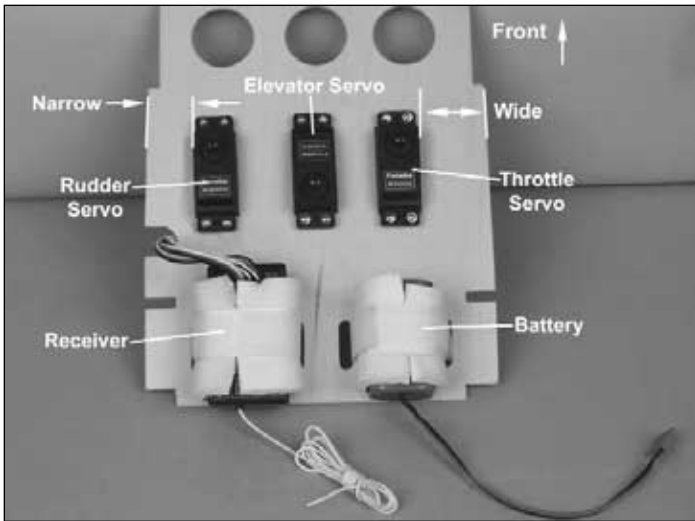

❑ 2. Install the rudder, elevator and throttle servos into the servo tray noting the orientation of the servos. Plug the battery and servos temporarily into the receiver. Center the elevator, rudder and throttle trims on the transmitter.

❑ 3. Route the three servo cords as shown in the photo and plug them into the receiver. Wrap the receiver and battery in foam rubber. Attach the receiver and battery to the servo tray using hook and loop material (not included).

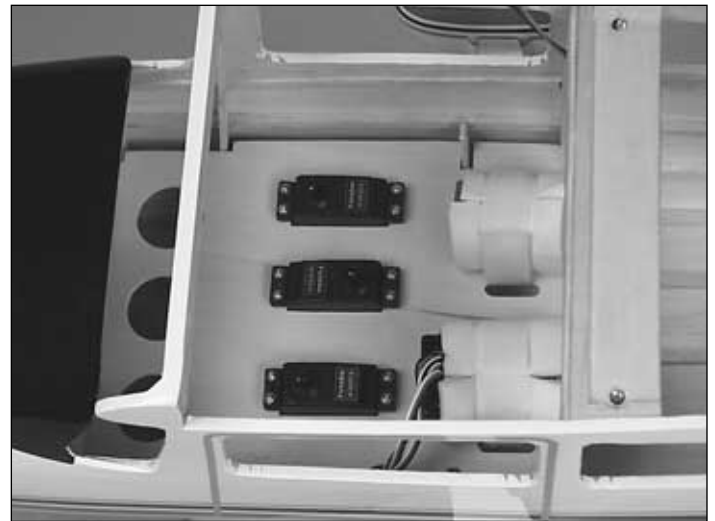

❑ 4. Test fit the servo tray into the fuselage. The battery and receiver are positioned towards the tail of the aircraft when the tray is installed. Begin by sliding the tray into the slot on former 2 as shown in the first photo. The second photo shows the tray fully seated against former 2. The last photo shows the tray fully seated against the landing gear formers. Once the tray fits without any binding or flexing, remove the tray and apply 30-minute epoxy to any areas in the fuselage that contact the servo tray. Install the tray and allow the epoxy to fully cure before proceeding to the next step.

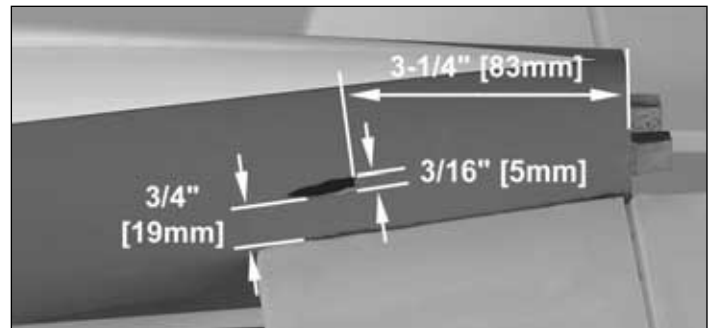

❑ 5. Cut the slots in both sides of the fuselage for the elevator pushrod tubes to exit the fuselage.



❑ 6. Use a 3/16" [5mm] drill bit or a sharpened 3/16" [5mm] brass tube to chamfer the holes for easier installation of the pushrod tubes.



7. Locate two 36" [914mm] **outer pushrod guide tubes** and scuff the outsides with coarse grit sandpaper. Route the tubes through the fuselage and into the radio compartment. The tubes must protrude at least 1/2" [13mm] from the fuse side exits. Glue the pushrod tubes into place using medium CA.



8. Cut the elevator pushrod tubes at the aft edge of the radio plate.

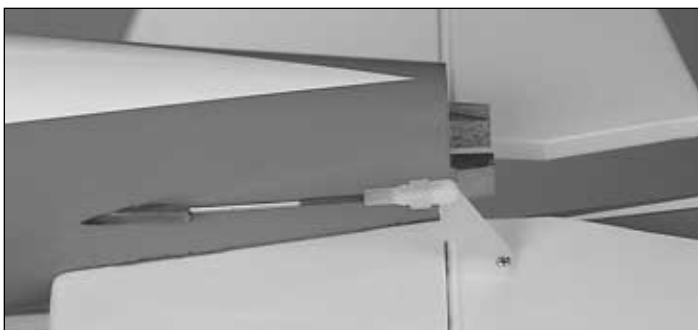

9. Insert two of the 2-56 x 36" **threaded end rods** into the elevator tubes in the fuselage. The pushrod should slide easily into the tube. Thread a nylon clevis on the pushrod 14-turns and add a silicone retainer to the clevis.

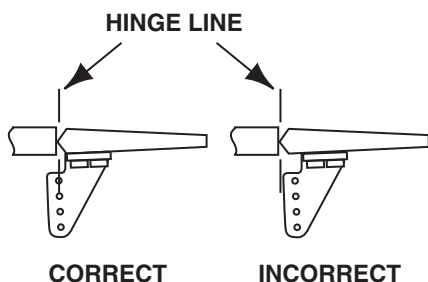

10. Install the elevator nylon control horns in line with the pushrods and as shown in the sketch. Hold the horns in

position and mark the location of the mounting holes. Drill 3/32" [2.5mm] mounting holes through the marks. Wick two to three drops of thin CA into the holes to harden the underlying balsa, then re-drill the holes. Attach the horns using four 2-56 x 5/8" machine screws and the nylon nut plates. Do not overtighten the screws, crushing the underlying balsa.



11. Center one of the elevators and elevator servo and mark the pushrod where it crosses the servo arm. Enlarge the servo horn hole with a 5/64" [2mm] drill bit.

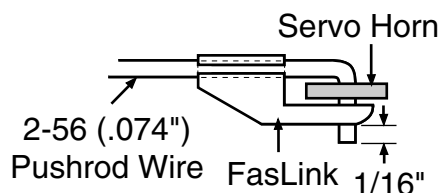

12. Slide two of the 5/32" **wheel collars** onto the pushrod wire that will attach to the elevator servo. Make a 90° bend in the pushrod on your mark, then insert it through the enlarged hole in the servo arm. Secure the wire in place with a nylon FasLink™ pushrod keeper. Trim the excess wire protruding from the FasLink as shown in the sketch.

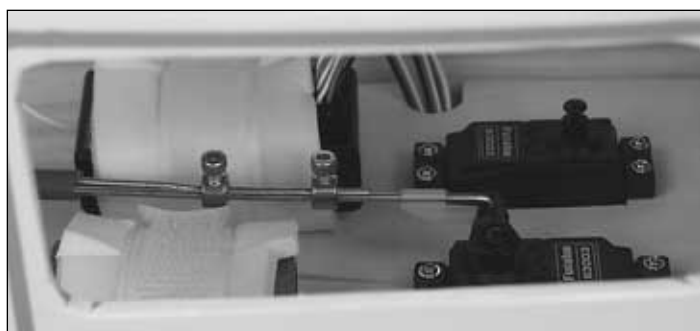

13. While keeping both elevators centered, connect the two elevator pushrods to each other with two 5/32" wheel collars and two 6-32 x 1/4" **socket head cap screws** as shown in the photo. Shorten the pushrod wire to prevent any interference at the FasLink or servo arm. Use thread lock on the screws to prevent loosening.

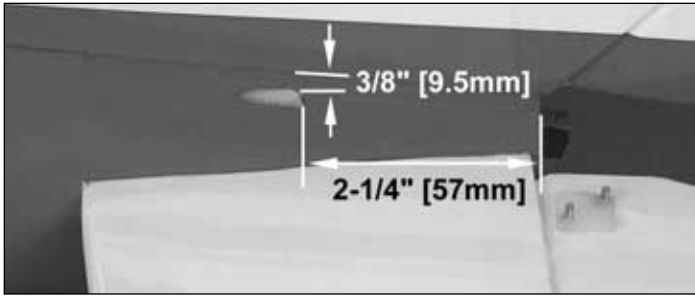

❑ 14. Cut a slot in the left side of the fuselage for the rudder pushrod tube to exit the fuselage.

❑ 15. Use a 3/16" [5mm] drill bit or a sharpened 3/16" [5mm] brass tube to chamfer the holes for easier installation of the pushrod tube.

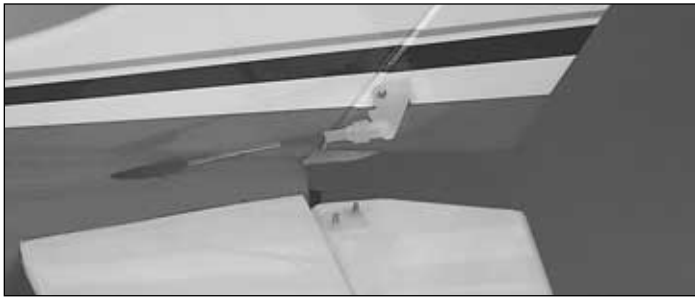

❑ 16. Locate a 36" [914mm] outer pushrod guide tube and scuff the outside with coarse grit sandpaper. Route the tube through the fuselage and into the radio compartment. The tube must protrude at least 1/2" [13mm] from the fuse side exits. Glue the tube to the fuselage using medium CA.

❑ 17. Insert one of the 2-56 x 36" threaded end rods into the rudder tube in the fuselage. The pushrod should slide easily into the tube. Thread a nylon clevis on the pushrod 14-turns and add a silicone retainer to the clevis.

❑ 18. Install the rudder nylon control horn in line with the pushrod. Hold the horn in position and mark the location of the mounting holes. Drill 3/32" [2.5mm] mounting holes through the marks. Wick two to three drops of thin CA into the holes to harden the underlying balsa, then re-drill the holes. Attach the horn using two 2-56 x 5/8" machine screws and a nylon nut plate. Do not overtighten the screws, crushing the underlying balsa.



❑ 19. Center the rudder and rudder servo and mark the pushrod where it crosses the servo arm. Enlarge the servo horn hole with a 5/64" [2mm] drill bit.

❑ 20. Make a 90° bend in the pushrod on your mark, then insert it through the enlarged hole in the servo arm. Secure the wire in place with a nylon FasLink pushrod keeper. Trim the excess wire protruding from the FasLink.

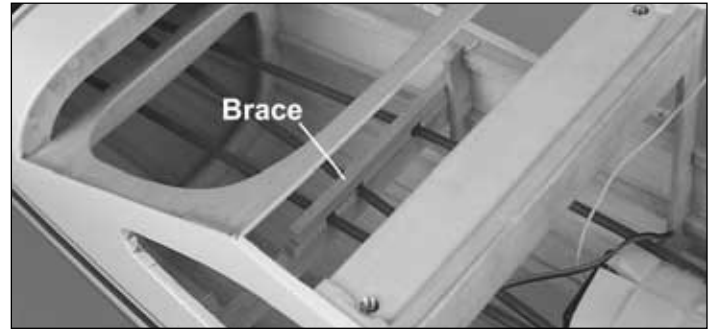

❑ 21. Once the rudder and elevator pushrods have been installed, a brace must be constructed to support the pushrods near the servo. Use balsa or mixing sticks to make the brace (not included). Position the brace so the pushrods will not bind when the controls are operated. Secure the brace using medium CA.

Aileron Servo Installation

Prepare **two** "cross" style servo horns as follows but don't install them on the servos until instructed to do so.

Note: The size and shape of servo horns varies from manufacturer to manufacturer. The sketches and photos show a typical radio installation with standard servo horns. All standard servo horns should fit in the Cessna 182.

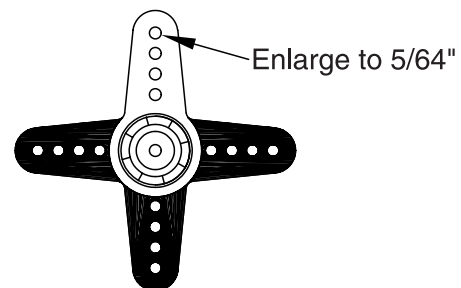

❑ A. Cut off three arms from **two** servo horns included with your radio control set to make them into "one arm" servo horns. Use your Bar Sander to remove the remaining jagged edges left from the cut-off arms.

❑ B. Enlarge the holes in the horns with a 5/64" [2mm] drill.

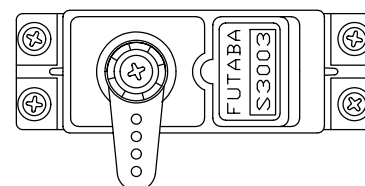

❑ C. Connect the aileron servos to the receiver. Turn on your transmitter and receiver, then position the aileron trim tabs

on your transmitter in the center. This is called “centering” the servos and will allow you to place the servo horns on the servos in a neutral position. Attach the arms to the servos using the following photo.

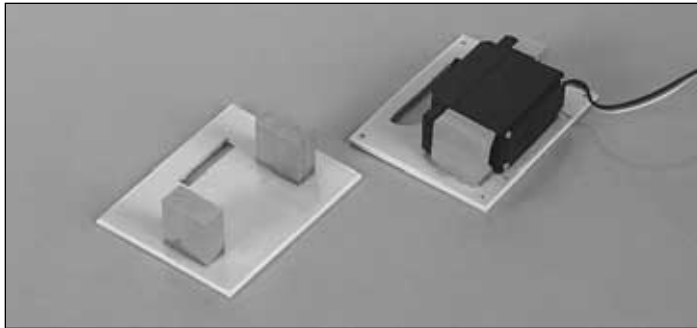

1. Trim the covering from the opening in the servo hatches. Position the servos onto the **aileron servo hatches** so the output shaft of the servo is centered in the opening in the hatch. Position the 3/8" x 3/4" x 3/4" [9.5mm x 19mm x 19mm] hardwood **servo mounting blocks** onto the hatches so there is a 1/32" [.8mm] gap between the blocks and the servo. Mark the locations of the blocks onto the hatch, and remove the servo. Use 30-minute epoxy to glue the blocks to the hatch. Install the aileron servos using the grommets, eyelets and screws that came with your radio system. After “*fishing*” the servo wires through to the opening at the center of the wing, plug them into a “Y” harness. Before permanently securing the servo hatches into position, hook up your radio and double-check the *centering* and *direction* of both of the aileron servos.

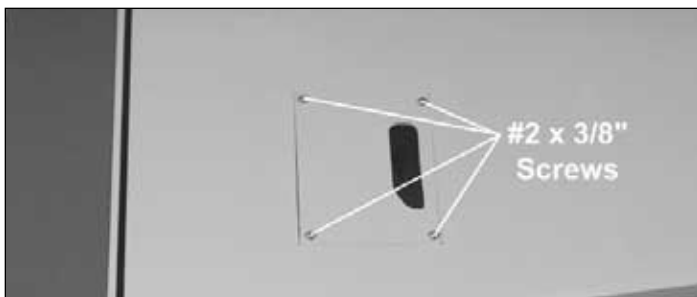

2. With the servo hatches in position, drill 1/16" [1.5mm] holes through the servo hatches and into the servo rails at each of the four corners. (It may be necessary to trim the hatch support rails as necessary to provide clearance for the servo mounting blocks.) Remove the hatches, and enlarge the holes in the hatches using a 3/32" [2.5mm] drill bit. Use #2 x 3/8" **sheet metal screws** to install the servo hatches. Trim the openings in the servo hatches as necessary to allow the clearance for the servo arm.

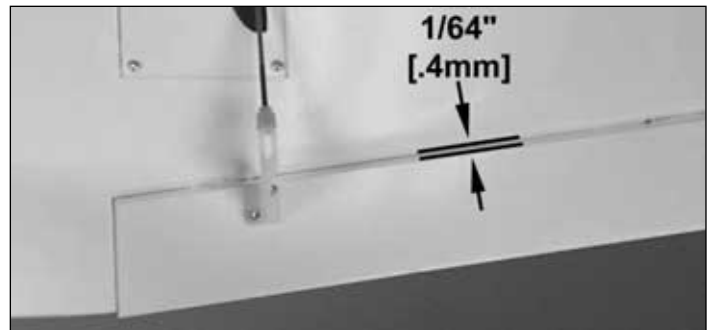
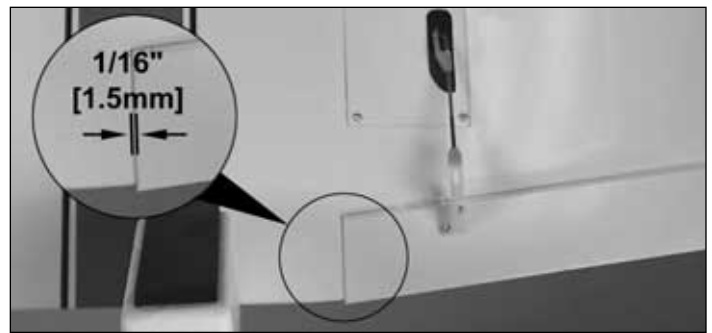

3. Cut six hinges from the hinge material. Install the **ailerons** using the hinges. Prepare the hinges and slots as shown on page 8. Push the ailerons against the trailing edge of the wing so there is approximately a 1/64" [.4mm] gap between the leading edge of the aileron and the trailing edge of the wing. Leave a gap of 1/16" [1.5mm] between the aileron and the wing as shown in the previous photo to allow the ailerons to move freely without binding against the wing. Add six drops of thin CA to the center of the hinges on both sides. Use a paper towel to absorb excess CA from the hinge gap before it cures. Do not use CA accelerator; allow the CA to cure slowly.

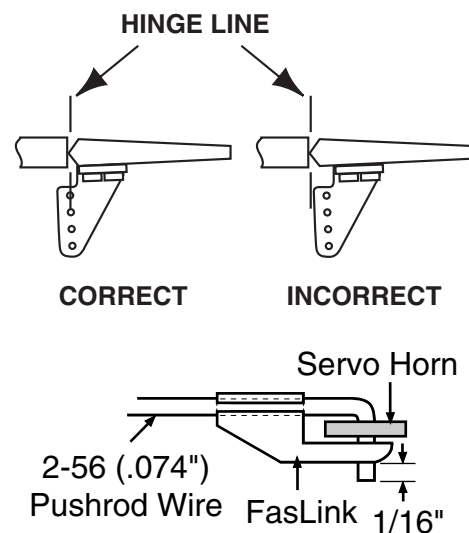

4. Two 2-56 x 6" **threaded end rods** are supplied to make the **aileron pushrods**. Thread a nylon clevis onto a pushrod 14-turns and add a silicone retainer to the clevis. Hold the horn in position on the bottom of the aileron. The horn must align with the servo arm, and as shown in the sketch. Mark the location of the mounting holes onto the aileron. Drill 3/32" [2.5mm] mounting holes through the

marks. Wick two to three drops of thin CA into the holes to harden the underlying balsa, then re-drill the holes. Attach the horns using 2-56 x 3/4" **socket head cap screws** and nylon **nut plates**. Do not overtighten the screws, crushing the underlying balsa. Center the ailerons, then mark the pushrods at the point where they meet the holes on the servo arm. Make a 90° bend in the wires at this mark. Cut off the excess wire 3/8" [9.5mm] above the bend. Insert the bent wire pushrod into the servo horn, then attach the linkage to the servo using a nylon FasLink™ as shown in the photo. Repeat this step for the other aileron linkage.

between the upper and lower sections of the nose gear block, and slide the nose gear through both sections of the nose gear block and the steering arm. The coil on the nose gear is positioned as close to the mount block as possible without binding. Use the photo and sketch to install the nose gear.

Steering Pushrod Installation

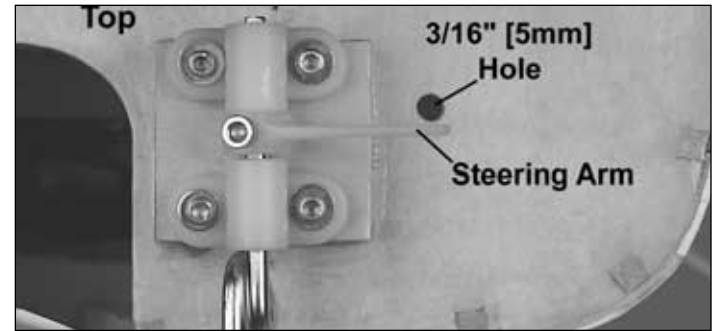

3. Drill a 3/16" [5mm] hole in the firewall for the nose gear pushrod tube. When drilling the hole, align it with the outside hole on the steering arm.



1. File a flat spot on the front of the nose gear wire where it passes through the nose gear bearing. This provides a better area for the screw to bite and helps keep the steering arm in place.



4. Now for the trickiest part of the assembly, routing the nose gear pushrod tube. The tube will enter from the front of the fuselage through the hole just drilled. Route the tube up through the servo tray **before** former 2. It will exit along side of the fuel tank above the servo tray and next to former 2. Trim former 2 to provide clearance for the tube and to properly align it with the servo arm. The photo shows the pushrod tube as it is properly routed.

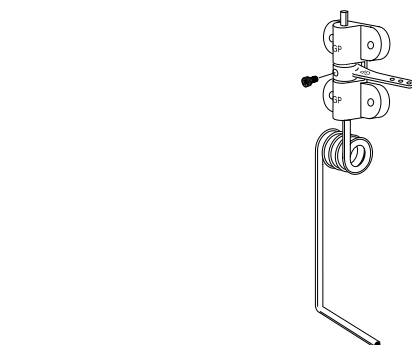
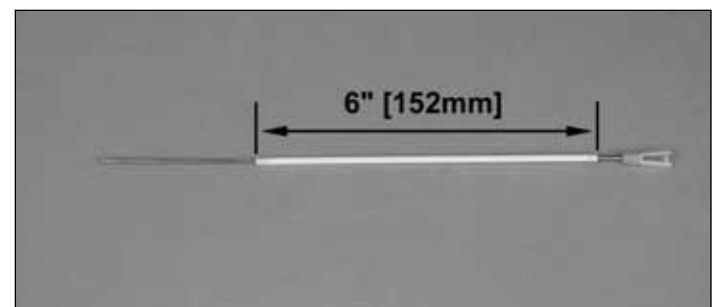
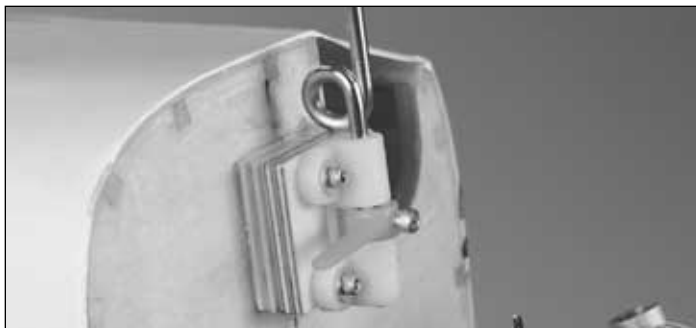

2. One 5/32" wheel collar, a nylon **steering arm**, and a 6-32 x 1/4" socket head cap screw are used to mount the nose gear. Place the wheel collar into the steering arm, making sure the hole in the arm aligns with the hole in the wheel collar for the set screw. Place the steering arm

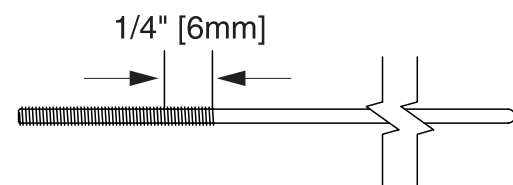

5. Assemble the steering pushrod using one nylon clevis, one clevis retainer, one 2-56 x 1" threaded rod, one 2-56 x

6" threaded one end rod and one inner pushrod tube. Cut the inner pushrod tube to a length of 6" [152mm]. Cut all but 1/4" [6mm] of the threads from the 2-56 x 6" threaded rod as shown in the sketch to prevent it from binding during operation.

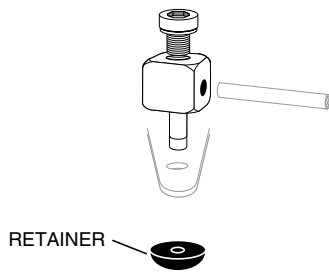

6. Install a brass **screw-lock pushrod connector** with the 4-40 x 1/8" **cap screw** on the steering arm. Snap the nylon **retainer** onto the screw-lock pushrod connector post beneath the arm.

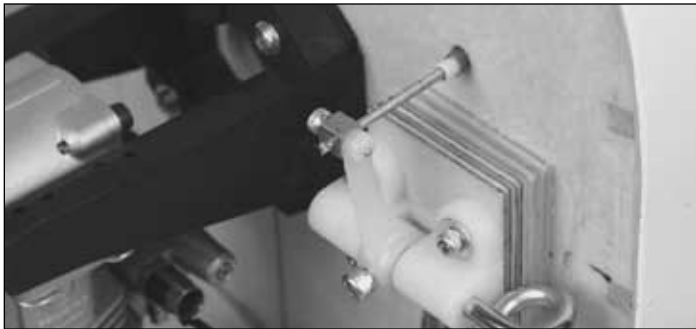

7. Install the **steering pushrod** by sliding it into the pushrod tube from inside the fuselage. As the rod exits the firewall, guide it through the pushrod connector on the steering arm. Attach the clevis to the servo arm. With the rudder servo centered, center the nose gear and tighten the 4-40 screw. Cut the excess pushrod 1/8" [3mm] forward of the pushrod connector.

Throttle Pushrod Installation

1. Install a brass screw-lock pushrod connector with the 4-40 x 1/8" cap screw on the throttle servo horn. Snap the nylon retainer onto the screw-lock pushrod connector post beneath the servo horn.

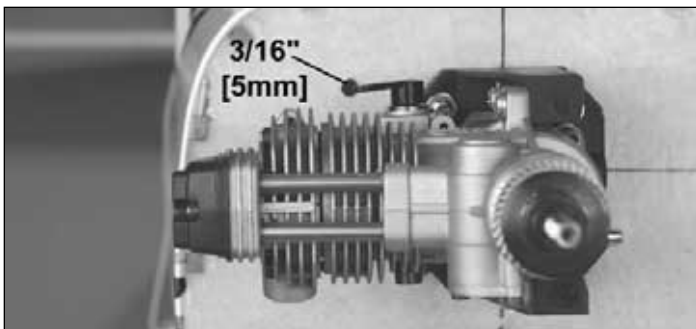

2. Drill a 3/16" [5mm] hole in the firewall for the throttle pushrod tube. When drilling the hole, align it with the outside hole on the throttle arm. Install the pushrod tube and secure it into place using medium CA.

3. Assemble the **throttle pushrod** using one nylon clevis, one clevis retainer, one 2-56 x 1" threaded rod, one 2-56 x 6" threaded one end rod and one inner pushrod tube. The throttle pushrod is assembled the same as the steering pushrod. Cut all but 1/4" [6mm] of the threads from the 2-56 x 6" threaded rod as shown in the sketch to prevent it from binding during operation. The length of the inner pushrod tubing will vary depending on your particular engine selection.



4. Insert the pushrod into the outer pushrod guide tube and through the screw-lock pushrod connector on the servo. Connect the clevis to the throttle arm on the engine, snap the clevis closed, then slide the retainer in place.



5. With the radio switched on, move the throttle trim and control stick to the fully closed position, by pulling them back (or downward) all the way. Manually close the throttle on the carburetor completely. Tighten the Cap Screw on the screw-lock pushrod connector. Check throttle operation with the radio and make adjustments to the linkages as necessary for smooth operation. Use the appropriate holes in the servo and throttle arms to provide the correct amount of throttle movement and to prevent the servo from binding at its end points.

FUEL TANK INSTALLATION

Note: There are three holes in the fuel tank stopper but only two are used for this model. Do not puncture the third hole in the stopper.

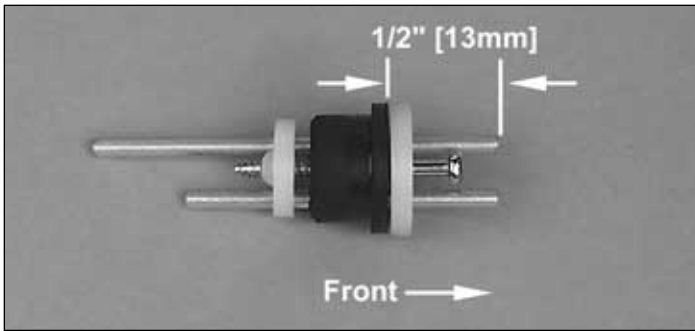

❑ 1. Push one **short aluminum tube** and one **long aluminum tube** through the **rubber stopper** until 1/2" [13mm] of the tubes protrude from the front of the stopper. Slide the **large cap** onto the front of the stopper, and the **small cap** onto the back. Insert the **stopper screw** into the center hole in the front cap, then thread it through the stopper into the aft stopper cap. Just start the threads in the aft cap or you won't be able to insert the stopper into the tank.

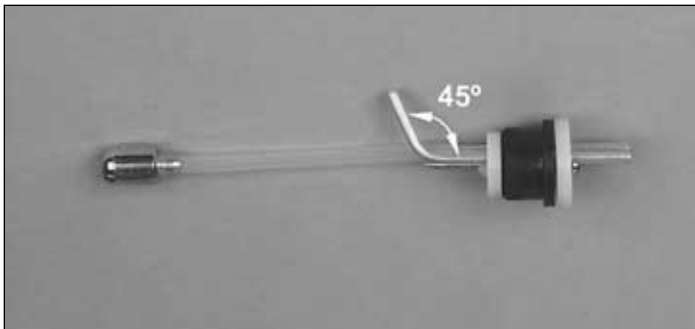

❑ 2. Push one end of the silicone **pickup tube** all the way onto the **clunk**, and the other end all the way onto the short aluminum tube. Bend the long aluminum (vent) tube upward at about a 45° angle, being careful not to kink the tube.

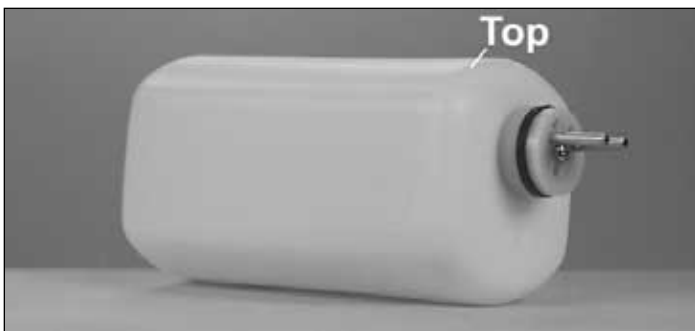

❑ 3. Test fit the stopper into the **fuel tank**. The seam around the tank should be vertical. By holding the tank up to the light you will be able to see where the vent tube is, in relation to the top of the tank. If necessary, bend the vent tube to position it about 1/8" [3mm] below the top of the tank. When satisfied with the fit, make sure the stopper is fully seated in the fuel tank. Tighten the stopper screw until the plastic cap is indented about 1/16" [1.5mm]. Doing so will lock the stopper into position. Check the clunk and pickup tube to make sure they move freely in the tank without binding. Mark the vent and clunk lines on the stopper so they can be identified when the tank is installed.



❑ 4. Cut two 8" [203mm] pieces of medium fuel tubing and attach them to the vent and clunk lines on the fuel tank. Slide the fuel tank into position, guiding the tubes through the hole in the firewall. Secure the position of the fuel tank as shown in the photo to prevent movement during flight. (The wood for securing the fuel tank is not included.)



❑ 5. Remove the covering from the fuselage in the location of the **muffler shield**. Test fit the shield into position. Trace around the shield, and remove the covering from the fuselage under the shield. Use medium CA to glue the shield into position.



❑ 6. Install the muffler for your particular engine. The location of the muffler shield is suitable for most engines. If your particular muffler does not line up, you may need to use an optional muffler. Attach the vent line to the muffler and the clunk line to the carburetor after cutting them to the proper length.

COWL INSTALLATION

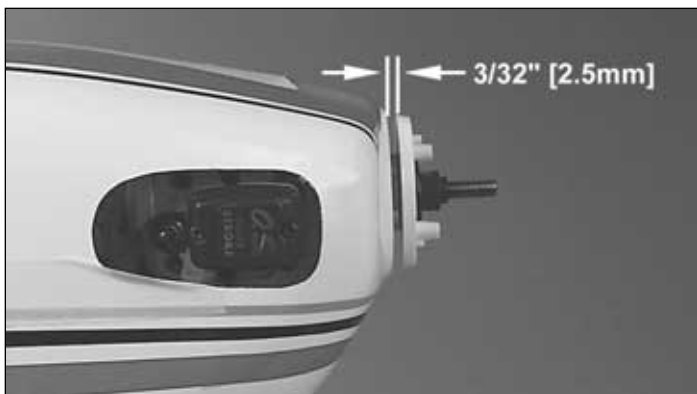

❑ 1. Slip the cowl over the front of the fuse. If the head of your engine interferes with the cowl, you can temporarily remove the head, or cut a hole in the cowl just large enough to accommodate the engine. After the cowl is mounted, you can enlarge the hole to allow some clearance for a more finished appearance.

❑ 2. Position the cowl on the fuse and mount the spinner to your engine. Use the stripes on the cowl and the fuselage as a cue for alignment. View the cowl carefully to make sure the cowl is centered horizontally and vertically on the spinner. Position the cowl so there is a 3/32" [2.5mm] gap between the cowl and the spinner backplate. Once the cowl has been aligned, use masking tape to hold the cowl in position.

❑ 3. Drill a 1/16" [1.5mm] hole through the cowl into the firewall. Place a #2 washer onto a #2 x 1/2" **sheet metal screw** and tighten it through the cowl just far enough into the firewall to temporarily hold that part of the cowl in place. Viewing the cowl from the front, drill a hole at the 2, 4, 8 and 10 o'clock positions. Insert a screw into cowl and firewall at each location. A total of four washers and screws are used to secure the cowl.

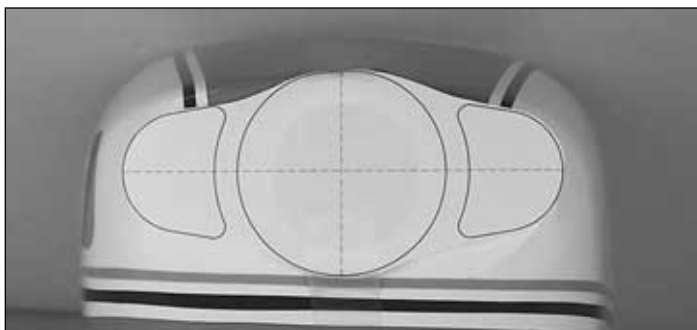

❑ 4. Remove the cowl and use the template from the back cover page to cut the air intake into the front of the cowling in front of the engine. On the opposite side, use black trim sheet (not included), to mock up the second opening. Only one opening is necessary to prevent overheating of the engine.

❑ 5. Once the air intake opening is cut out, install the cowling onto the fuselage. Make any final adjustments to the openings for the head of the engine, nose gear and muffler. Also cut holes to allow for the needle valve, glow plug access and any other adjustment you may have to make to the engine while the cowl is installed.

WINDOW INSTALLATION



❑ 1. Carefully trim the **windshield** along the cut lines with scissors or Lexan® shears. Test fit the windshield on the fuse as you proceed, making small adjustments as required for a good fit.

❑ 2. If you wish to paint the windshield (and the rest of the windows), test the paint on a scrap of the canopy material to make sure the paint is compatible. Straight out of the spray can, Top Flite LustreKote® is not recommended for painting the clear plastic your windshield is made from and will eventually curl it. But, if you have an airbrush, it is possible to paint your windshield with LustreKote; however, you **must** use the following procedure. Spray an ounce or two of LustreKote through a tube (such as a large drinking straw or a brass tube) into a container. Let it sit for about an hour or two to allow the damaging elements to "boil off." Using an air brush, you may now spray your windshield with your specially prepared LustreKote. For airbrushing, we recommend thinning LustreKote with lacquer thinner. If you prefer to spray your windshield frame directly from a spray

can, we have had success with Pactra Formula-U and Chevron paint. **Always test your painting methods on leftover plastic** before you try it on your model!

❑ 3. Roughen the outside 1/8" [3mm] of the inside windshield edge, being careful not to scratch any exposed areas. Glue the canopy into position with 6-minute epoxy or R/C-56 glue.

❑ 4. Trim the **side windows** so 1/16" [1.5mm] remains for the windows to rest on the inside of the fuselage. Because the windows fit recessed into the fuselage from the inside, this lip must remain on the windows. Roughen the outside edges of the windows and glue them inside the fuselage with 6-minute epoxy or R/C-56 glue.

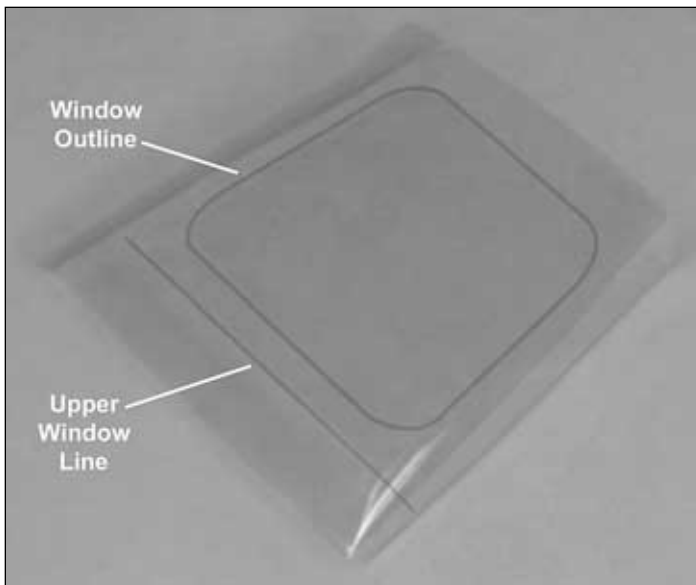

❑ 5. Trim the rear window by removing the lip from the outer edge. **Do not cut to the window outline.**



❑ 6. Place the wing into position and slightly tighten the wing bolts. Slide the rear window underneath the wing. The rear window is positioned correctly when the upper window line is against the trailing edge of the wing.

❑ 7. Use the photos on the box in trimming the window. There should be at least 1/4" [6mm] overlap of the rear window onto the fuselage along each side of the window, and 1/2" [13mm] at the rear. Once trimmed, paint the edge of the window to match the fuselage. Glue the rear window to the fuselage using 6-minute epoxy or R/C-56 glue.

FINAL ASSEMBLY



❑ 1. Position the **tail cone** onto the aft end of the fuselage. The tail cone aligns with the rudder when it is in the neutral position. Leave a constant gap between the rudder and tail cone. Drill the locations for the two #2 x 3/8" sheet metal screws using a 1/16" [1.5mm] drill bit. Wick two to three drops of thin CA into the holes to harden the underlying balsa. Enlarge the holes in the tail cone using a 3/32" [2.5mm] drill bit. Attach the tail cone to the fuselage using the two sheet metal screws.



❑ 2. Roughen the inside of the wing tips using 120-grit sandpaper. Attach the **wing tips** to the wing using medium CA. Leave a 1/16" [1.5mm] gap between the aileron and wing tip.

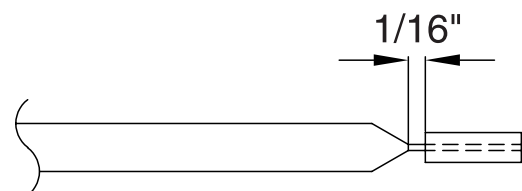

❑ 3. Prepare the struts by inserting the strut ends into the struts. Position the end so there is a 1/16" [1.5mm] gap

between the end and the strut. Glue the strut ends to the struts using thin CA.



❑ 4. Locate the small mark locating the strut mounting block for the fuselage. Drill a 1/16" [1.5mm] hole into the fuselage at the mark. Drill a 3/32" [2.5mm] hole in the center of both strut ends. Wick two to three drops of thin CA into the holes to harden the underlying balsa. Attach the strut to the fuselage using a #2 x 1/2" sheet metal screw and a #2 washer.

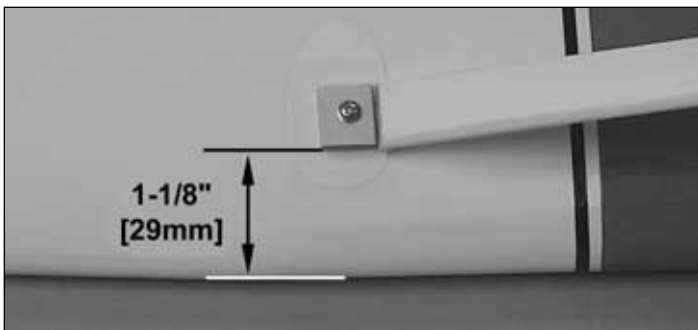

❑ 5. Position the end of the strut 1-1/8" [28mm] behind the leading edge of the wing. Drill a 1/16" [1.5mm] hole into the strut mounting block through the strut end. Secure the strut to the wing using a #2 x 1/2" sheet metal screw and a #2 washer.

❑ 6. Trim the plastic strut fairing using a hobby knife and scissors. Round the corners of the strut ends to allow each strut fairing to fit properly. Use the photos on the box as a guide when trimming each fairing. Drill a 3/16" [5mm] hole in each fairing to allow access to the attachment screws. Use medium CA or 6-minute epoxy to glue each strut fairing to the strut.

RADIO SYSTEM SET-UP

Check the Control Directions

Turn on the transmitter and then the receiver. Standing behind the plane, make the following movements with the transmitter and observe the control surfaces:

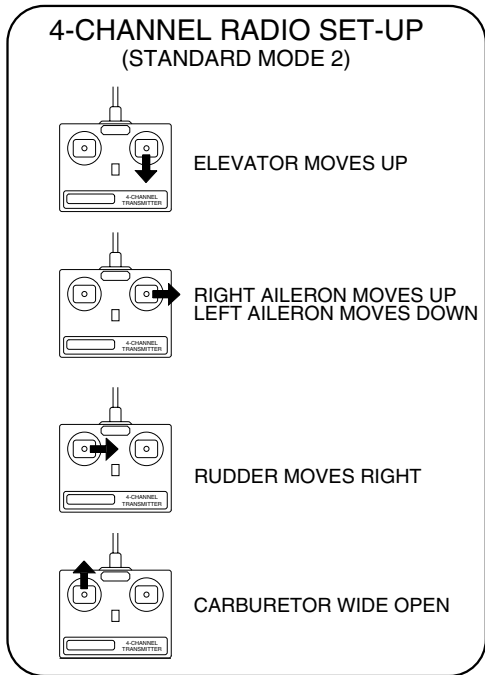

If any of the servo movements are wrong, reverse the servo direction with the servo reversing switches on the transmitter.

Adjust the Control Throws

Check the movement of the control surfaces. Use a ruler to match our measurements listed below.

Aileron	1/4" [6mm] up 1/4" [6mm] down
Elevator	7/16" [11mm] up 7/16" [11mm] down
Rudder	1-7/8" [48mm] left 1-7/8" [48mm] right

These are the suggested deflections from the center of the control surfaces.

If you need more control movement, you should move the clevis to a hole closer to the control surface or you can move the rod at the servo away from the center of the servo. If you have too much movement, do the opposite. See the following sketches:

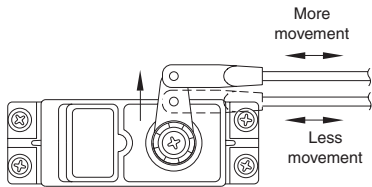

Moving the clevis outward on the servo arm results in more pushrod movement.

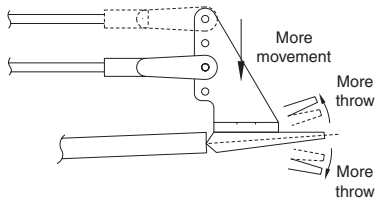

Moving the clevis inward on the control horn results in more throw.



One leading cause of crashes is flying an airplane with its control throws set differently from those recommended in the instructions. The Great Planes AccuThrow™ lets you quickly and easily measure actual throws first, so you can make necessary corrections before you fly. Large, no-slip rubber feet provide a firm grip on covered surfaces without denting or marring the finish. Spring tension holds AccuThrow's plastic ruler steady by each control surface. Curved to match control motions, the ruler provides exact readings in both standard or metric measurements. **GPMR2405.**

Route the Receiver Antenna

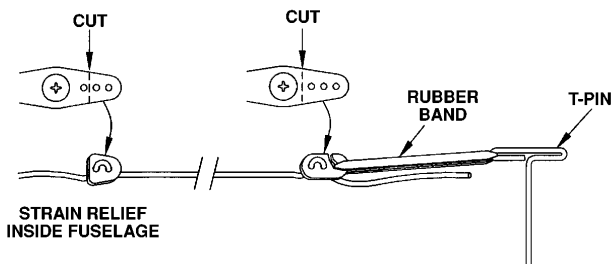

Route the antenna to the tail of the model. You may use your preferred method or the method we use in the Great Planes

model shop. Drill a 1/4" [6mm] hole through the fuse side in the proximity of the receiver. Cut a 1/2" [13mm] long piece of fuel tubing and install it in the hole. Install a strain relief (as shown in the sketch), then route the antenna through the fuel tubing to the bottom of the fuse at the tail. Use a rubber band to attach the antenna to a T-pin at the aft end of the fuselage. Do not cut or shorten the antenna wire. Leave any excess to hang free.

BALANCE YOUR MODEL

Check the Lateral Balance

Special Note: Do not confuse this procedure with "checking the C.G." or "check the fore-aft balance."

Now that you have the basic airframe completed, this is a good time to balance the airplane laterally (side-to-side). Here is how to do it:

1. Attach the wing to the fuselage.
2. With the wing level, lift the model by the engine propeller shaft and the fin post (this may require two people). Do this several times.

If one wing always drops when you lift the model, it means that side is heavy. Balance the airplane by gluing weight to the other wing tip. **Note:** An airplane that has been laterally balanced will track better in loops and other maneuvers.

Check the Fore-Aft Balance

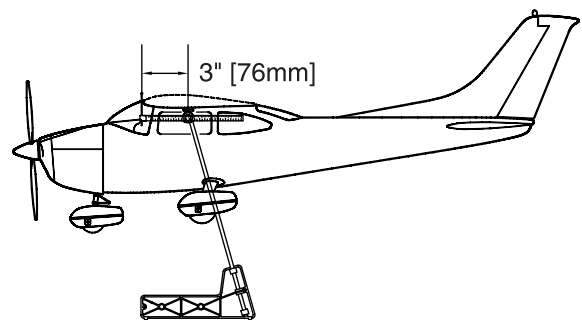

Note: This section is **VERY** important and must **NOT** be omitted! A model that is not properly balanced will be unstable and possibly unflyable.

The balance point (C.G.) is located 3" [76mm] back from the leading edge of the wing against the fuselage. Balance your Cessna using a Great Planes C.G. Machine™ Airplane Balancer (GPMR2400) for the most accurate results. This is the balance point at which your model should balance for your first flights. After initial trim flights and when you become more acquainted with your Cessna, you may wish to experiment by shifting the balance up to 1/4" [6mm]

forward or backward to change its flying characteristics. Moving the balance forward may improve the smoothness and stability, but the model may then require more speed for takeoff and may become more difficult to slow for landing. Moving the balance aft makes the model more agile with a lighter, snappier “feel.” In any case, please start at the location we recommend. Do not at any time balance your model outside the recommended range.

With the wing attached to the fuselage, all parts of the model installed (ready to fly), and an **empty** fuel tank, hold the model at the marked balance point with the stabilizer level.

Lift the model. If the tail drops when you lift, the model is “tail heavy” and you must add weight* to the nose. If the nose drops, it is “nose heavy” and you must add weight* to the tail to balance.

Note: Nose weight may be easily installed by using a spinner weight (GPMQ4645 for the 1 Oz. weight, or GPMQ4646 for the 2 Oz. weight) or gluing lead weights to the firewall. Tail weight may be added by using Great Planes “stick-on” lead weights (GPMQ4485).

*If possible, first attempt to balance the model by changing the position of the receiver battery and receiver. If you are unable to obtain good balance by doing so, then it will be necessary to add weight to the nose or tail to achieve the proper balance point.

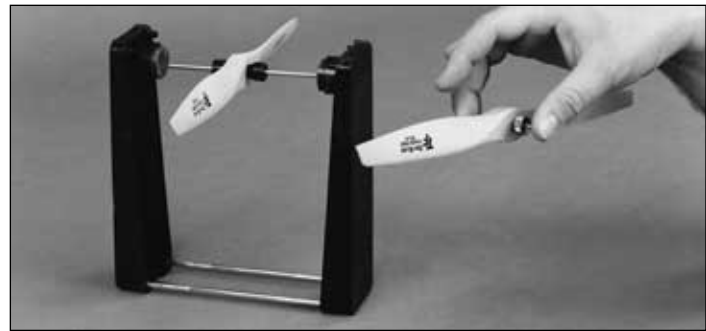

We use a Top Flite Precision Magnetic Prop Balancer™ (TOPQ5700) in the workshop and keep a Great Planes Fingertip Balancer (GPMQ5000) in our flight box.

Find a Safe Place to Fly

The best place to fly your R/C model is an AMA (Academy of Model Aeronautics) chartered club field. Ask your hobby shop dealer if there is such a club in your area and join. Club fields are set up for R/C flying and that makes your outing safer and more enjoyable. The AMA also can tell you the name of a club in your area. We recommend that you join the AMA and a local club so you can have a safe place to fly and have insurance to cover you in case of a flying accident. (The AMA address and phone numbers are listed on page 2 of this instruction manual).

If a club and its flying site are not available, you need to find a large, grassy area at least 6 miles away from any other R/C radio operation like R/C boats and R/C cars and away from houses, buildings and streets. A schoolyard may look inviting but it is too close to people, power lines and possible radio interference.

PREPARING TO FLY YOUR CESSNA 182

Charge the Batteries

Follow the battery charging procedures in your radio instruction manual. You should always charge your transmitter and receiver batteries the night before you go flying, and at other times as recommended by the radio manufacturer.

Balance the Propeller

Balance your propellers carefully before flying. An unbalanced prop is the single most significant cause of damaging vibration. Not only will engine mounting screws and bolts vibrate out, possibly with disastrous effect, but vibration will also damage your radio receiver and battery. Vibration will cause your fuel to foam, which will, in turn, cause your engine to run rough or quit.

Ground Check the Model

If you are not thoroughly familiar with the operation of R/C models, ask an experienced modeler to check to see that you have the radio installed correctly and that all the control surfaces do what they are supposed to. The engine operation also must be checked and the engine “broken-in” on the ground by running the engine for at least two tanks of fuel. Follow the engine manufacturer’s recommendations for break-in. Check to make sure all screws remain tight, that the hinges are secure and that the prop is on tight.

Range Check Your Radio

Wherever you do fly, you need to check the operation of the radio every time before you fly. First, make sure no one else is on your frequency (channel). With the transmitter antenna collapsed and the receiver and transmitter on, you should be able to walk at least 100 feet away from the model and still have control. Have someone help you. Have them stand by your model and, while you work the controls, tell you what the various control surfaces are doing.

Repeat this test with the engine running at various speeds with an assistant holding the model. If the control surfaces are not always acting correctly, do not fly! Find and correct the problem first.

Engine Safety Precautions

Note: Failure to follow these safety precautions may result in severe injury to yourself and others.

Keep all engine fuel in a safe place, away from high heat, sparks or flames, as fuel is very flammable. Do not smoke near the engine or fuel; and remember that the engine exhaust gives off a great deal of deadly carbon monoxide. Therefore do not run the engine in a closed room or garage.

Get help from an experienced pilot when learning to operate engines.

Use safety glasses when starting or running engines.

Do not run the engine in an area of loose gravel or sand, as the propeller may throw such material in your face or eyes.

Keep your face and body as well as all spectators away from the plane of rotation of the propeller as you start and run the engine.

Keep items such as these away from the prop: loose clothing, shirt sleeves, ties, scarfs, long hair or loose objects (pencils, screwdrivers) that may fall out of shirt or jacket pockets into the prop.

Use a "chicken stick" device or electric starter; follow the instructions supplied with the starter or stick. Make certain the glow plug clip or connector is secure so that it will not pop off or otherwise get into the running propeller.

Make all engine adjustments from behind the rotating propeller.

The engine gets hot! Do not touch it during or after operation. Make sure fuel lines are in good condition so fuel will not leak onto a hot engine, causing a fire.

To stop the engine, cut off the fuel supply by closing off the fuel line or follow the engine manufacturer's recommendations. Do not use hands, fingers or any body part to try to stop the engine. Do not throw anything into the prop of a running engine.

AMA SAFETY CODE (excerpt)

Read and abide by the following Academy of Model Aeronautics Official Safety Code excerpt:

General

1. I will not fly my model aircraft in sanctioned events, air shows, or model flying demonstrations until it has been

proven to be airworthy by having been previously successfully flight tested.

2. I will not fly my model aircraft higher than approximately 400 feet within 3 miles of an airport without notifying the airport operator. I will give right of way to, and avoid flying in the proximity of, full-scale aircraft. Where necessary an observer shall be used to supervise flying to avoid having models fly in the proximity of full-scale aircraft.

3. Where established, I will abide by the safety rules for the flying site I use, and I will not willfully and deliberately fly my models in a careless, reckless and/or dangerous manner.

7. I will not fly my model unless it is identified with my name and address or AMA number, on or in the model.

9. I will not operate models with pyrotechnics (any device that explodes, burns, or propels a projectile of any kind)

Radio Control

1. I will have completed a successful radio equipment ground check before the first flight of a new or repaired model.

2. I will not fly my model aircraft in the presence of spectators until I become a qualified flier, unless assisted by an experienced helper.

3. I will perform my initial turn after takeoff away from the pit or spectator areas, and I will not thereafter fly over pit or spectator areas, unless beyond my control.

4. I will operate my model using only radio control frequencies currently allowed by the Federal Communications Commission.

FLYING YOUR CESSNA 182

The Cessna 182 is a great flying sport airplane that flies smoothly and predictably, yet is highly maneuverable. It does not have the self-recovery characteristics of a primary trainer. Therefore, you must either have mastered the basics of R/C flying or seek the assistance of a competent R/C pilot to help you with your first flights.

Takeoff

Although the Cessna 182 has great low speed characteristics, you should always build up as much speed as your runway will permit before lifting off, as this will give you a safety margin in case of a "flame-out." When the plane has sufficient flying speed, lift off by smoothly applying a little up elevator (don't "force" it off to a vertical climb!), and climb out gradually.

Flying

We recommend that you take it easy with your Cessna 182 for the first several flights and gradually “get acquainted” with this fantastic ship. Add and practice one maneuver at a time, learning how she behaves in each one. Spins and inverted spins are also performed with ease.

Landing

When it's time to land and you cut the throttle, you'll notice a very slight climbing tendency at first, which bleeds off some speed; then it assumes the normal glide angle, slightly nose down.

Have a ball! But always stay in control and fly in a safe manner.

GOOD LUCK AND GREAT FLYING!

OTHER ITEMS AVAILABLE FROM GREAT PLANES

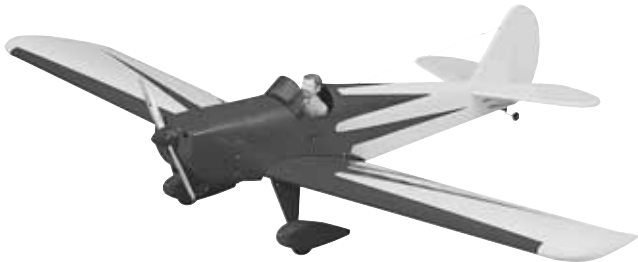

SpaceWalker ARF GPMA1300

Based on Jesse Anglin's '86 tribute to '30s homebuilts, the SpaceWalker takes only a few hours to assemble. It has a strong, wood frame; welded, steel landing gear; side plates; ABS wheel pants; windshield; and a cowl color-matched to the MonoKote covering. Smooth in flight, it blends the muscle of dual aileron servos with the aerobatic potential of a symmetrical airfoil. **Note:** Pilot figure not included.



Piper J-3 Cub ARF GPMA1310

This sport-scale model is all-wood, impressively detailed, and flight-ready in as little as 15-20 hours! Surrounding the CAD-engineered framework is real woven Coverite™ 21st Century® fabric. With its dual aileron servos the Cub maneuvers well. It also lands gently and includes a pre-painted fiberglass cowl, replica cylinder heads, adjustable engine mount and Great Planes-brand hardware. **Note:** Pilot figure not included.



AT-6 Texan ARF GPMA1245

Enjoy smooth flight and easy aerobatics with this kit-quality ARF. Precision-molded, painted parts include a glass-reinforced cowl. Plus, the AT-6 offers the strength of wood...the dependability of Great Planes hardware...and the fine finish of Top Flite MonoKote film. Fixed landing gear is supplied, though wheel wells and mounting rails are built-in for retracts. **Note:** Pilot figure not included.



Giles G-202 GPMA1315

Designed to convince “kitters” that ARFs can be outstanding! Parts interlock for strength, and are all-wood except for fiberglass parts factory-painted to match the preapplied MonoKote covering. Competition mounted servos (2 each for ailerons and elevators, 1 for the rudder) plus double-beveled rudder and elevator control surfaces open the way for wild, 3D stunts. **Note:** Pilot figure not included.



Extra 300 ARF GPMA1240

It's the aerobat that's engineered for ease, and precovered in Top Flite MonoKote film, the choice of fliers worldwide! Rounded aluminum gear add scale looks, along with prepainted ABS wheel pants and a 1-piece cowl that conceals most engines. In the air, dual aileron servos and independently adjustable elevator yokes increase control precision and authority. **Note:** Pilot figure not included.



Master Caddy™ Field Box w/APS GPMR1000

Constructed of sturdy ply, the Master Caddy comes ready to assemble and can be finished however you wish. It measures 25" x 15.75" x 8.25" with large drawers and roomy compartments to carry all of your field gear. Flight line essentials go in the lightweight, removable Auxiliary Power Station (APS). Cushioned, adjustable-width cradles hold your model safely for cleanup and maintenance.

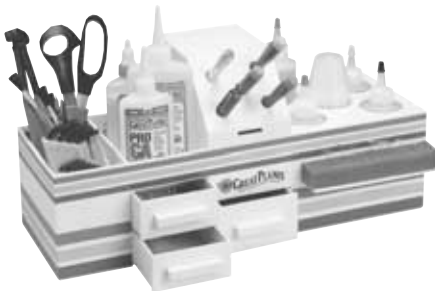

Bench Topper™ GPMR8500

The Great Planes Bench Topper hold the inexpensive answer to building supply storage and organization hassles. It assembles quickly into a 15.5" x 7.5" x 5.25" caddy that fits comfortably on any bench—or can be mounted conveniently on a wall. The lite ply parts simply CA together. Knives, scissors, paint brushes, CA and epoxy bottles, mixing

cups...the Bench Topper offers a place for everything. You can even customize its top center-section to suit your special storage needs! **GPMR8500**



Quick Field Charger HCAM3000

The Quick Field Charger recharges 9.6V transmitter and 4.8V or 6.0V receiver batteries right on the spot, using any 12V DC input. Advanced Delta peak sensing technology automatically switches to trickle once batteries are fully charged. Unique voltage boost circuitry peaks transmitter NiCds even in diode-equipped radios. Includes 2.5A fuse, alligator clips on a 14" input cord and banana plugs. 2-year warranty. Connectors required.



ProGlo™ NiCd Starter Clips GPMP2012

The chrome-plated socket is a tip-off to the dependability underneath. Knurled, anodized aluminum barrel unscrews so depleted NiCds can be replaced--and ProGlo can keep the glow power coming.



Engine Mount Template

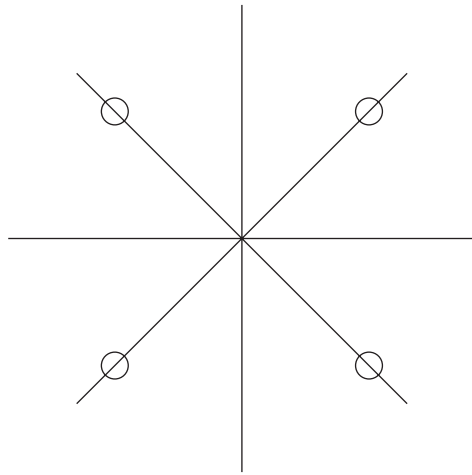

Refer to this template when instructed in this manual.

Cowl Opening Template

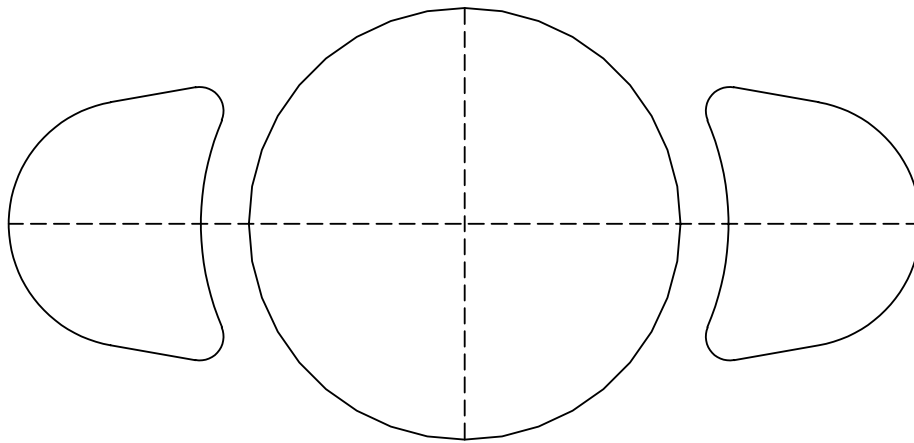

Refer to this template when instructed in this manual.