

PATRIOT XL

INSTRUCTION MANUAL



Wingspan: 55 in [1,395mm]
Wing Area: 742 sq in [47.9dm²]
Weight: 8-8.5 lb [3630-3860g]
Wing Loading: 25-27 oz/sq ft [76-82g/dm²]
Length: 59.5 in [1150mm]
Radio: 6-Channel with 6 standard servos
Engine: .61-.91 cu. in. [10-15cc] two-stroke
.61-.91 cu. in. [10-15cc] four-stroke

WARRANTY

Great Planes® Model Manufacturing Co. guarantees this kit to be free from defects in both material and workmanship at the date of purchase. This warranty does not cover any component parts damaged by use or modification. **In no case shall Great Planes' liability exceed the original cost of the purchased kit.** Further, Great Planes reserves the right to change or modify this warranty without notice.

In that Great Planes has no control over the final assembly or material used for final assembly, no liability shall be assumed nor accepted for any damage resulting from the use by the user of the final user-assembled product. By the act of using the user-assembled product, the user accepts all resulting liability.

If the buyer is not prepared to accept the liability associated with the use of this product, the buyer is advised to return this kit immediately in new and unused condition to the place of purchase.

To make a warranty claim send the defective part or item to Hobby Services at the address below:

Hobby Services
3002 N. Apollo Dr. Suite 1
Champaign, IL 61822
USA

Include a letter stating your name, return shipping address, as much contact information as possible (daytime telephone number, fax number, e-mail address), a detailed description of the problem and a photocopy of the purchase receipt. Upon receipt of the package the problem will be evaluated as quickly as possible.

READ THROUGH THIS MANUAL BEFORE STARTING CONSTRUCTION. IT CONTAINS IMPORTANT INSTRUCTIONS AND WARNINGS CONCERNING THE ASSEMBLY AND USE OF THIS MODEL.



Champaign, IL
(217) 398-8970, Ext. 5
Fax: (217) 398-7721
airsupport@greatplanes.com

TABLE OF CONTENTS

INTRODUCTION	2
SAFETY PRECAUTIONS	3
DECISIONS YOU MUST MAKE	3
Radio Equipment	3
Flaps	3
Retracts	4
ADDITIONAL ITEMS REQUIRED	4
Hardware and Accessories	4
Adhesives and Building Supplies	4
Optional Supplies and Tools	4
IMPORTANT BUILDING NOTES	5
TYPES OF WOOD	6
GET READY TO BUILD	6
DIE-CUT PATTERNS	6
BUILD THE TAIL SURFACES	8
Build the Stabilizer	8
Build the Fin	8
Sheet the Fin and Stabilizer	8
Build the Rudder and Elevators	10
Finish the Tail Surfaces	11
BUILD THE WING	11
Build the Wing Panels	11
Sheet the Wing Panel Top	14
Install the Landing Gear Rails	16
Begin Shaping the Wing	16
Install the Retracts	17
Install the Fixed Gear	18
Join the Wing Panels	19
Sheet the Bottom of the Wing	20
Install the Ailerons	21
Finish Shaping the Wing	21
BUILD THE FUSELAGE	21
Assemble the Fuse Formers and Sides	21
Install the Firewall	23
Mount the Wing	25
Finish the Bottom of the Fuselage	26
Build the Turtle Deck	27
Install the Radio Hatch	29
Mount the Stabilizer to the Fuse	30
Mount the Fin to the Fuse	30
Install the Fuel Tank	31
Mount the Engine	32
Install the Servos and Pushrods	33
Assemble the Instrument Panel (Optional)	35
Assemble the Cowl	35
Install the ABS Plastic Details	36
INSTALL THE HARDWARE	37
BALANCE THE MODEL Laterally	37
PREPARE THE MODEL FOR COVERING	37
FINAL SERVO & RECEIVER INSTALLATION	37
COVER THE MODEL WITH MONOKOTE® FILM	38
PAINT THE MODEL	38
Apply the Decals	39
Install the Canopy	39
Attach the Control Surfaces	39
GET THE MODEL READY TO FLY	40
Check the Control Directions	40

Set the Control Throws	40
Balance the Model (C.G.)	41
PREFLIGHT	41
Identify Your Model	41
Charge the Batteries	41
Balance Propellers	42
Ground Check	42
Range Check	42
ENGINE SAFETY PRECAUTIONS	42
AMA SAFETY CODE (EXCERPT)	43
General	43
Radio Control	43
CHECKLIST	43
FLYING	44
Takeoff	44
Flight	44
Landing	44
APPENDIX: FLIGHT TRIMMING	45
FLIGHT TRIMMING CHART	46
FLIGHT LOG	47
2-VIEW DRAWING	Back Cover

INTRODUCTION

The larger, faster, easier-to-build Patriot XL expands on the incredible popularity and performance of the original Great Planes Patriot kit. Designed around .60-.90 size engines, whether 2-stroke or 4, the Patriot XL provides amazing performance in an easy-to-build sport scale kit. Add the optional retracts and flaps to the thin, Selig-airfoil wing, and your Patriot XL goes from quick to blistering fast AND is easy to settle in for carrier-like landings.

For the latest technical updates or manual corrections to the Great Planes Patriot XL, visit the Great Planes web site listed below. Open the "Airplanes" link, and then select the Great Planes Patriot XL. If there is new technical information or changes to this model, a "tech notice" box will appear in the upper left corner of the page.

<http://www.greatplanes.com/airplanes/index.html>

We urge you to join the AMA (Academy of Model Aeronautics) and a local R/C club. The AMA is the governing body of model aviation and membership is required to fly at AMA clubs. Though joining the AMA provides many benefits, one of the primary reasons to join is liability protection. Coverage is not limited to flying at contests or on the club field. It even applies to flying at public demonstrations and air shows. Failure to comply with the Safety Code (excerpts printed in the back of the manual) may endanger insurance coverage. Additionally, training programs and instructors are available at AMA club

sites to help you get started the right way. There are over 2,500 AMA chartered clubs across the country. Contact the AMA at the address or toll-free phone number below:



Academy of Model Aeronautics

5151 East Memorial Drive

Muncie, IN 47302

Tele: (800) 435-9262

Fax (765) 741-0057

Or via the Internet at:

<http://www.modelaircraft.org>

IMPORTANT!!!

Two of the most important things you can do to preserve the radio controlled aircraft hobby are to avoid flying near full-scale aircraft and avoid flying near or over groups of people.

**PROTECT YOUR MODEL, YOURSELF
& OTHERS...FOLLOW THESE
IMPORTANT SAFETY PRECAUTIONS**

1. Your Great Planes Patriot XL should not be considered a toy, but rather a sophisticated, working model that functions very much like a full-size airplane. Because of its performance capabilities, the Great Planes Patriot XL, if not assembled and operated correctly, could possibly cause injury to yourself or spectators, and damage to property.

2. You must assemble the model **according to the instructions**. Do not alter or modify the model, as doing so may result in an unsafe or unflyable model. In a few cases the instructions may differ slightly from the photos. In those instances the written instructions should be considered as correct.

3. You must take time to **build straight, true and strong**.

4. You must use an R/C radio system that is in first-class condition and a correctly sized engine and components (fuel tank, wheels, etc.) throughout the building process.

5. You must correctly install all R/C and other components so that the model operates correctly on the ground and in the air.

6. You must check the operation of the model before every flight to insure that all equipment is operating and that the model has remained structurally sound. Be sure to check clevises or other connectors often and replace them if they show any signs of wear or fatigue.

7. If you are not an experienced pilot or have not flown this type of model before, we recommend that you get the assistance of an experienced pilot in your R/C club for your first flights. If you're not a member of a club, your local hobby shop has information about clubs in your area whose membership includes experienced pilots.

8. While this kit has been flight tested to exceed normal use, if the plane will be used for extremely high stress flying, such as racing, the modeler is responsible for taking steps to reinforce the high stress points.

We, as the kit manufacturer, provide you with a top quality, thoroughly tested kit and instructions, but ultimately the quality and flyability of your finished model depends on how you build it; therefore, we cannot in any way guarantee the performance of your completed model, and no representations are expressed or implied as to the performance or safety of your completed model.

Remember: Take your time and follow the instructions to end up with a well-built model that is straight and true.

Before starting to build, compare the parts in this kit with the Parts List, and note any missing parts. Also inspect all parts to make sure they are of acceptable quality. If any parts are missing, broken or defective, or if you have any questions about building or flying this airplane, please contact Great Planes at the address or telephone number below. If requesting replacement parts, please provide the full kit name (Great Planes Patriot XL) and the part numbers as listed in the Parts List.

Great Planes Product Support:

3002 N Apollo Drive Suite 1

Champaign, IL 61822

Telephone: (217) 398-8970, Fax: (217) 398-7721

E-mail: productsupport@greatplanes.com

DECISIONS YOU MUST MAKE

This is a partial list of items required to finish the Patriot XL that may require planning or decision making before starting to build. Order numbers are provided in parentheses.

Radio Equipment

You must use a minimum of a 6-channel radio with two Y-harnesses, one for the ailerons and one for the elevators. Due to the fact that the two elevator servos move in opposition, you will have to have either a computer radio, or a servo reverser that will allow you to reverse one of the servos. If using a Futaba® radio, the **SR10 servo reverser (FUTM4150)** is recommended. One **standard Y-harness (HCAM2500)** will also be required for the two aileron servos.

Flaps

The Patriot XL may be built either with or without flaps. Flaps are not necessary for an enjoyable flying experience. Landing with flaps is a blast (and can be safer) because the

model is able to land at reduced speeds. Full instructions are included for building the Patriot XL with flaps, but a little extra craftsmanship and skill (not to mention a little extra time) will be required.

These additional items are required to build the Patriot XL with flaps:

- (2) Standard servos
- (1) Y-harness (HCAM2701 Futaba®)
- (1) 6" [150mm] Servo extension for flaps (HCAM2000 for Futaba)

Retracts

The Patriot XL may be built with either fixed or retractable landing gear. Fixed landing gear wires are included with this kit, so the only additional items required to build the Patriot XL with fixed gear is (2) 2-1/2" [65mm] wheels, and one 2-1/4" [58mm] wheel. If installing retracts, the kit may be built to accommodate Robart #605 HD retracts with 3/6" [4.8mm] wire struts (ROBQ0005). **Note:** If installing any other system, the landing gear rail spacing and/or position may require modification to accommodate the gear. Whichever retract system is installed, an additional servo will be required to operate the air control valve.

These items are required if installing Robart retractable landing gear:

- Robart #605HD 90-degree retracts for main gear (3/16" [4.8mm] wire struts) (ROBQ0005)
- Robart #607 90-Degree retract for the nose gear (3/16" [4.8mm] wire strut) (ROBQ1807)
- Robart #188 Air control kit (ROBQ2388)
- 3/16" x 2" [4.8 x 51mm] slip-on axles (GPMQ4278)
- (2) Robart #190 Quick connectors (ROBQ2395, pair)
- (2) 2-1/2" [65mm] Main wheels (GPMQ4223)
- (1) 2-1/4" [57mm] Nose wheel (GPMQ4222)
- Robart #164G Hand Pump with Gauge (ROBQ2363)
- Standard servo to operate air control valve

ADDITIONAL ITEMS REQUIRED

In addition to the items listed in the "Decisions You Must Make" section, following is the list of hardware and accessories required to finish the Great Planes Patriot XL. Order numbers are provided in parentheses.

Hardware and Accessories

- Top Flite® Super MonoKote® covering:
 - Aluminum (TOPQ0205, 2 rolls)
 - Royal Blue (TOPQ0221, 1 roll)
 - White (TOPQ0204, 1 roll)
 - Missile Red (TOPQ0201, 1 roll)
- Fuelproof paint - See Painting (page 34)
- 12 oz. Fuel tank (GPMQ4105)

- 3' Medium fuel tubing (GPMQ4131)
- Nylon reinforced packing tape
- 2-1/4" [57mm] Tru-Turn Ultimate Spinner (TRUQ2282)

Adhesives and Building Supplies

In addition to common household tools (screwdrivers, drill, etc.), this is the "short list" of the most important items required to build the Great Planes Patriot XL. *We recommend Great Planes Pro™ CA and Epoxy glue.*

- 2 oz. Pro CA (Thin, GPMR6003)
- 2 oz. Pro CA+ (Medium, GPMR6009)
- 30-Minute Pro Epoxy (GPMR6047)
- Canopy Glue (PAAR3300)
- Microballoons (TOPR1090)
- Hobby knife handle (HCAR0105)
- #11 Blades (HCAR0311), 100 Qty.
- X-ACTO® Razor Saw (XACR2531)
- Small T-pins (HCAR5100)
- Medium T-pins (HCAR5150)
- Masking tape (TOPR8018)
- Bondo® or Squadron white (or green) putty
- 1/4-20 Tap (GPMR8105, drill bit included)
- Top Flite Sealing Iron (TOPR2100)
- Hand or electric power drill
- Drill bits: 1/16" [1.6mm], 5/64" [2mm], 3/32" [2.4mm], 7/64" [2.8mm], 1/8" [3.2mm], 9/64" [3.6mm], 5/32" [4mm], 11/64" [4.4mm], 3/16" [4.8mm], 13/64" [5.2mm], 7/32" [5.6mm], 15/64 [6mm], 1/4" [6.4mm], 17/64" [6.7mm], 9/32" [7.1mm]
- Heat Shrink Tubing (GPMM1070)

Optional Supplies and Tools

Here is a list of optional tools mentioned in the manual that will help you build the Great Planes Patriot XL.

- Precision Magnetic Prop Balancer™ (TOPQ5700)
- Panel Line Pen (TOPQ2510)
- Dead Center™ Engine Mount Hole Locator (GPMR8130)
- AccuThrow™ Deflection Gauge (GPMR2405)
- Precision Hinge Marking Tool (GPMR4005)
- Slot Machine™ hinge slotting tool (110V, GPMR4010)
- Groove Tube™ (GPMR8140)
- Plan Protector (GPMR6167)
- CA Clevis installation tool (GPMR8030)
- Heat gun (TOPR2000)
- Tack Cloth (TOPR2185)
- Hot Sock™ (TOPR2175)
- Razor plane (MASR1510)
- Single-edge razor blades (HCAR0312, 100 Qty.)
- 36" Non-slip straightedge (HCAR0475)
- Denatured or isopropyl alcohol (for epoxy clean-up)
- Dremel® Moto-Tool® or similar w/sanding drum, cutting burr and cut-off wheel
- Servo horn drill (HCAR0698)
- Epoxy brushes (GPMR8060)
- Epoxy mixing sticks (GPMR8055, Qty. 50)

- CA Debonder (GPMR6039)
- CG Machine™ (GPMR2400)
- 2 oz. [57g] spray CA activator (GPMR6035) or 4 oz. [113g] aerosol CA activator (GPMR634)
- CA applicator tips (HCAR3780)
- 3M 75 repositionable spray adhesive (MMMR1900)
- Builder's Triangle Set (HCAR0480)
- Metal Template Set (30/60/90/45° triangles, HCAR0500)
- Curved-tip canopy scissors for trimming plastic parts (HCAR0667)
- Robart Super Stand II (ROBP1402)
- 24"x36" [460x910mm] Builder's Cutting Mat (HCAR0456)
- 16"x48" [410x1220mm] building board (GPMR6950)
- Hobbico Duster™ compressed air (HCAR5500)
- Z-bend pliers (HCAR2000)
- 1 oz. Pro CA- (Thick, GPMR6014)
- 6-Minute Pro™ Epoxy (GPMR6045)

IMPORTANT BUILDING NOTES

- There are two types of screws used in this kit:

Sheet metal screws are designated by a number and a length.



For example #6 x 3/4"

This is a number six screw that is 3/4" long.

Machine screws are designated by a number, **threads per inch**, and a length. **SHCS** is just an abbreviation for "socket head cap screw" and that is a machine screw with a socket head.

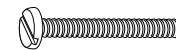

For example 4-40 x 3/4".

This is a number four screw that is 3/4" long with forty threads per inch.

- When you see the term **test fit** in the instructions, it means that you should first position the part on the assembly **without using any glue**, then slightly modify or custom fit the part as necessary for the best fit.

- Whenever the term **glue** is written you should rely upon your experience to decide what type of glue to use. When a specific type of adhesive works best for that step, the instructions will make a recommendation.

- Whenever just **epoxy** is specified you may use **either** 30-minute (or 45-minute) epoxy **or** 6-minute epoxy. When 30-minute epoxy is specified it is **highly** recommended that you use only 30-minute (or 45-minute) epoxy, because you will need the working time and/or the additional strength.

- **Photos** and **sketches** are placed **before** the step they refer to. Frequently you can study photos in following steps to get another view of the same parts.

- Not all die-cut parts have a name, or their complete name stamped on them, so refer to the die drawings for identification. When it's time to remove the parts from their die sheets, if they are difficult to remove, do not force them out. Instead, use a sharp #11 blade to carefully cut the part from the sheet and then lightly sand the edges to remove any slivers or irregularities. Save some of the larger scraps of wood.



EASY-TOUCH™ BAR SANDER

A flat, durable, easy to handle sanding tool is a necessity for building a well finished model. Great Planes makes a complete range of Easy-Touch Bar Sanders and replaceable Easy-Touch Adhesive-backed Sandpaper. While building the Patriot XL, two 5-1/2" [140mm] Bar Sanders and two 11" [280mm] Bar Sanders equipped with 80-grit and 150-grit Adhesive-Backed Sandpaper were used.

Here's the complete list of Easy-Touch Bar Sanders and Adhesive Backed Sandpaper:

5-1/2" Bar Sander (GPMR6169)

11" Bar Sander (GPMR6170)

22" Bar Sander (GPMR6172)

33" Bar Sander (GPMR6174)

44" Bar Sander (GPMR6176)

11" Contour Multi-Sander (GPMR6190)

12' roll Adhesive-backed 80-grit sandpaper (GPMR6180)

150-grit (GPMR6183)

180-grit (GPMR6184)

220-grit (GPMR6185)

Assortment pack of 5-1/2" strips (GPMR6189)

We also use Top Flite 320-grit (TOPR8030, 4 sheets) and 400-grit (TOPR8032, 4 sheets) wet-or-dry sandpaper for finish sanding.

COMMON ABBREVIATIONS

Fuse = Fuselage
 Stab = Horizontal Stabilizer
 Fin = Vertical Fin
 LE = Leading Edge
 TE = Trailing Edge
 LG = Landing Gear
 Ply = Plywood
 " = Inches
 mm = Millimeters
 SHCS = Socket Head Cap Screw

TYPES OF WOOD

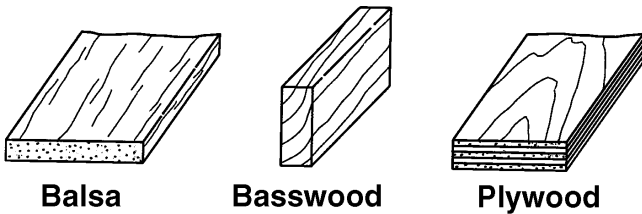

Balsa

Basswood

Plywood

GET READY TO BUILD

- ❑1. Unroll the plan sheets. Re-roll the plan inside out to make them lie flat.
- ❑2. Remove all parts from the box. As you do, figure out the name of each part by comparing it with the plan and the parts list included with this kit. Using a felt-tip or ballpoint pen, lightly write the part **name** or **size** on each piece to avoid confusion later. Use the die-cut patterns to identify the die-cut parts and mark them **before** removing them from the sheet. **Save all leftovers.** If any of the die-cut parts are difficult to punch out, do not force them! Instead, cut around the parts with a hobby knife. After punching out the die-cut parts, use your bar sander to **lightly** sand the edges to remove any die-cutting irregularities or slivers.
- ❑3. As you identify and mark the parts, separate them into groups, such as **fuse** (fuselage), **wing**, **fin**, **stab** (stabilizer) and **hardware**.

DIE-CUT DRAWINGS

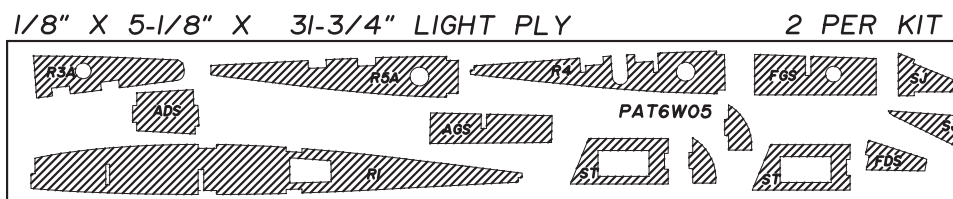
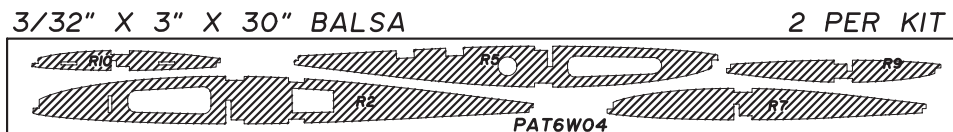
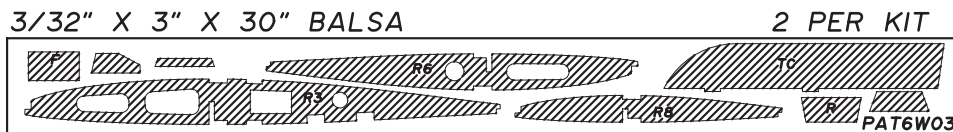
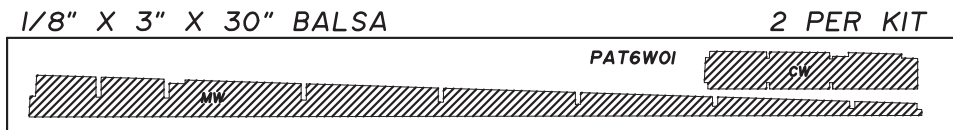
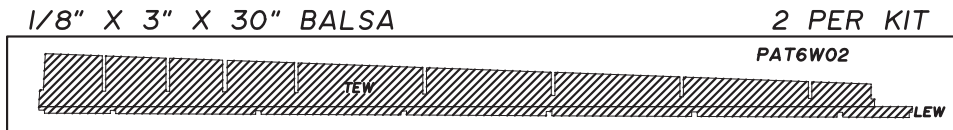

DIE-CUT DRAWINGS

1/8" X 4-1/8" X 31-3/4" LIGHT PLY 1 PER KIT

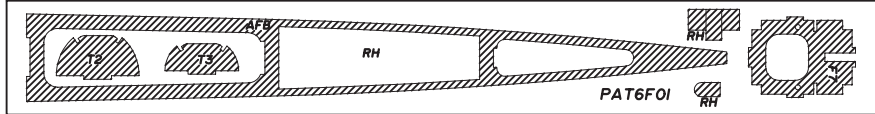

1/8" X 5-1/8" X 31-3/4" LIGHT PLY 1 PER KIT

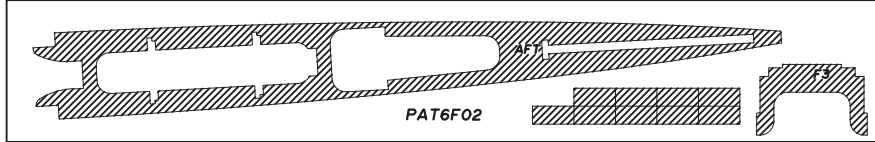

1/8" X 5-1/8" X 31-3/4" LIGHT PLY 1 PER KIT

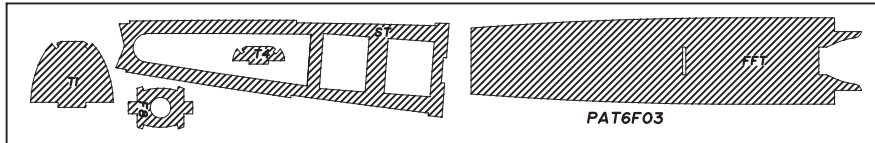

1/8" X 5-1/8" X 31-3/4" LIGHT PLY 1 PER KIT

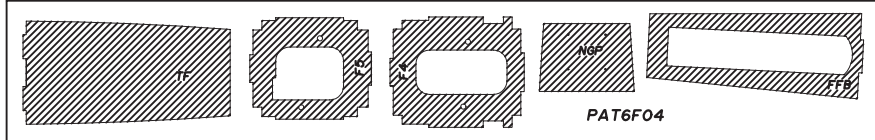

1/8" X 5-1/8" X 31-3/4" LIGHT PLY 1 PER KIT

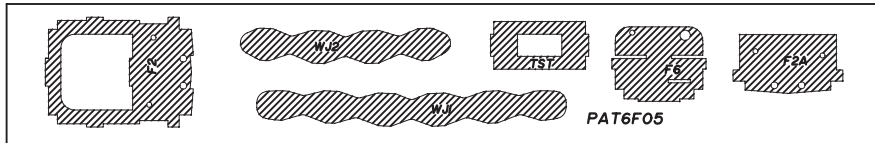

1/8" X 5-1/8" X 31-3/4" LIGHT PLY 2 PER KIT

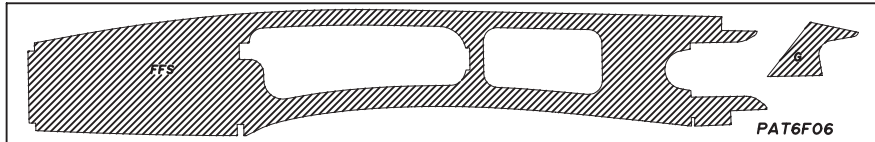

1/8" X 5-1/8" X 31-3/4" LIGHT PLY 2 PER KIT

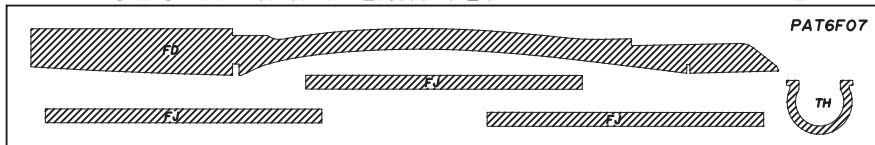

1/8" X 5-1/8" X 31-3/4" LIGHT PLY 2 PER KIT

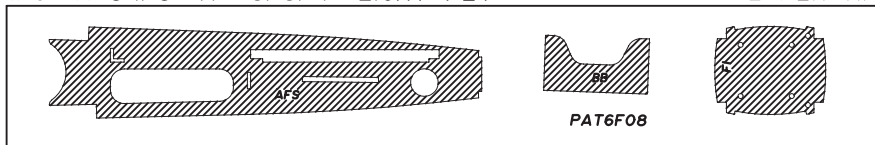

1/16" X 7-1/4" X 4-3/8" BIRCH PLY 1 PER KIT

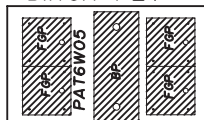

BUILD THE TAIL SURFACES

Build the Stabilizer

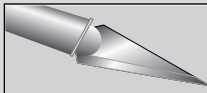

EXPERT TIP
EXPERT TIP

Note: While the placement of the outer framing of any stick-built part is important, the exact placement of the internal ribs is not so critical. It is more important to have strong, secure glue joints than to have the ribs placed in the exact location.

Note: We have removed the parts from the plan for clarity in the some of the photos.

❑ 1. Position the fuse plan so the stab plan is over your flat building board. Cover the plan with Great Planes Plan Protector or wax paper so glue will not adhere. You may cut the stabilizer drawing from the fuse plan along the dashed lines if you wish.

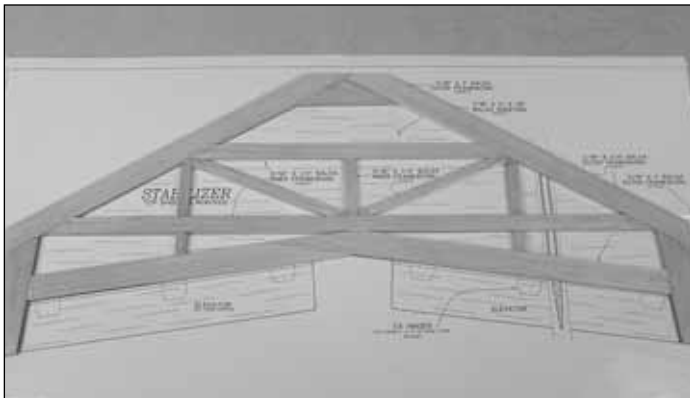

❑ 2. Build the stabilizer framework using the balsa sticks indicated on the plan. Start with the 3/16" x 3/4" x 24" [4.8 x 19 x 610mm] **outer framework**, then the 3/16" x 1/2" x 24" [4.8 x 13 x 610mm] and 3/16" x 1/4" x 24" [4.8 x 6 x 609mm] **inner framework**. Finish with 3/16" x 1" x 18" [4.8 x 25 x 460mm] **stab tips**. As you proceed, use T-pins to hold the sticks to the plan and use **thin CA** to glue the parts together. **Note:** Save any leftover sticks as they will be used for building the fin.

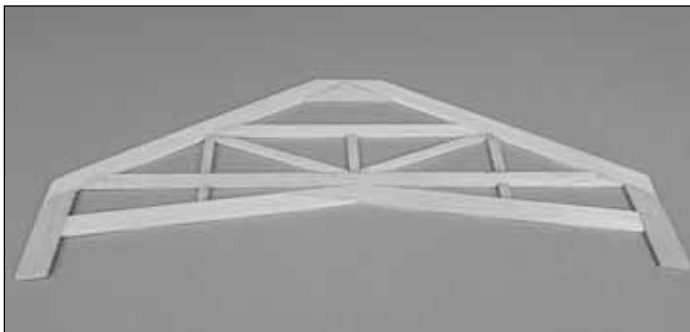

❑ 3. Remove the stab from the plan. Inspect all glue joints and re-glue as necessary. Use a bar sander and 220-grit

sandpaper to sand both sides of the stab framework flat. Be careful while sanding so that you do not over-thin any one particular area of the stab or gouge the stab framework by snagging sandpaper on it.

Build the Fin

❑ 1. Place the fin plan on the building surface and cover with wax paper or plan protector.

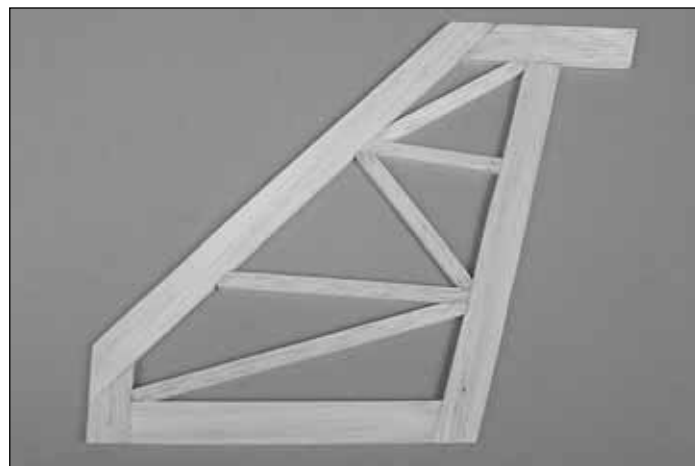

❑ 2. Using the leftover 3/16" [4.8mm] balsa sticks from the stab assembly, build the fin in the same manner as the stab.

❑ 3. Remove the fin from the plan. Add thin CA to any joints needing more glue. Sand flat using 220-grit sandpaper and a bar sander.

Sheet the Fin and Stabilizer

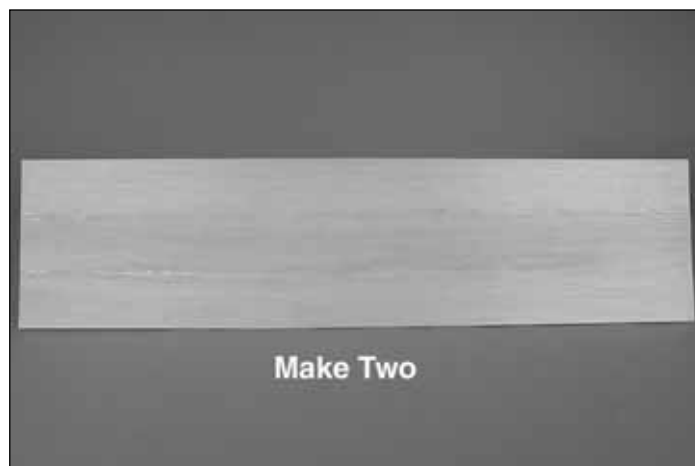

❑ ❑ 1. Use the method described in the **Expert Tip** that follows or your favorite method to glue together three 1/16" x 3" x 36" [1.6 x 95 x 760mm] balsa sheets to make one 1/16" x 9" x 36" [1.6 x 230 x 760mm] stab/fin skin. Make another skin the same way.



HOW TO JOIN SHEETING

Note: Aliphatic resin can be used to join the sheeting, but takes longer than CA to dry. If you choose to join using aliphatic resin, be sure to allow the sheeting to sit a few hours for the glue to dry. Aliphatic resin sands easier than CA and is easier to cut.

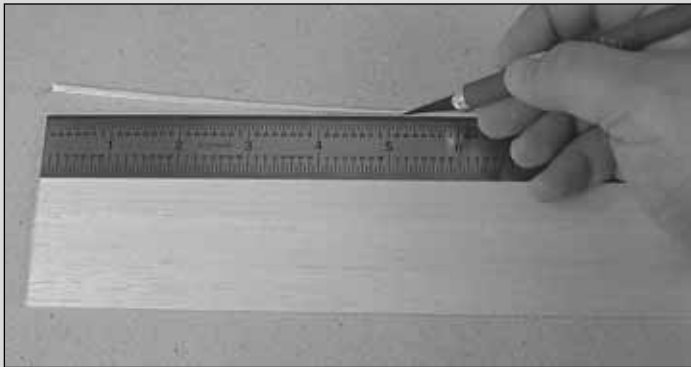

A. Use a straightedge as a guide to trim one edge of both sheets.

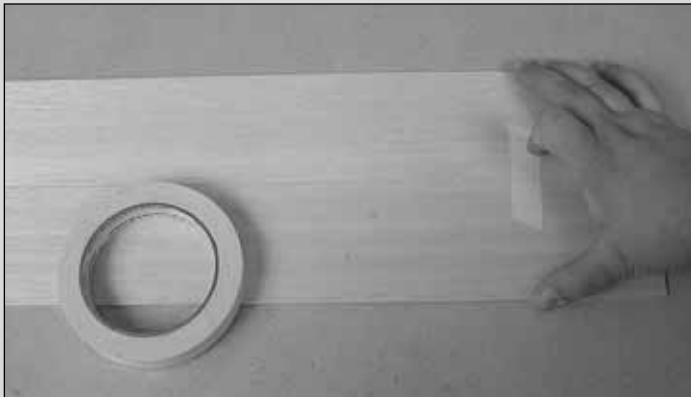

B. Use masking tape to tightly tape the two sheets together joining the trimmed edges.



C. Turn the sheet over and place weights on top of the sheet to hold it. Apply thin CA sparingly to the seam, quickly wiping away excess CA with a paper towel as you proceed.

D. Turn the sheet over and remove the masking tape. Apply thin CA to the seam the same way you did for the other side and use a fresh paper towel to wipe away excess CA.

E. Sand the sheeting flat and smooth with your bar sander and 220-grit sandpaper.

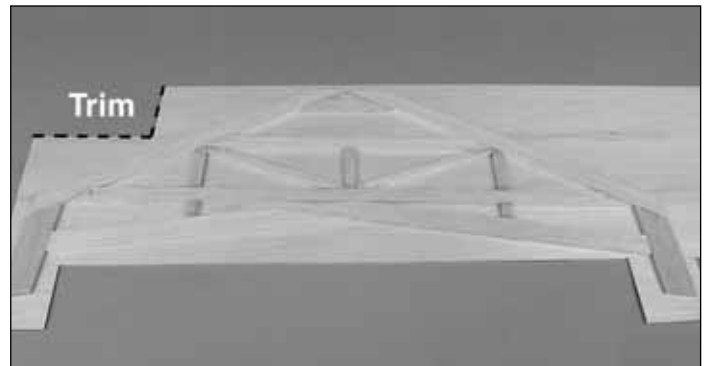

2. Working over your **flat** building surface, use medium CA to glue one side of the stab to one of the skins as shown in the photo. Sheet the ends of the stab tips with a small corner cut from the area shown.

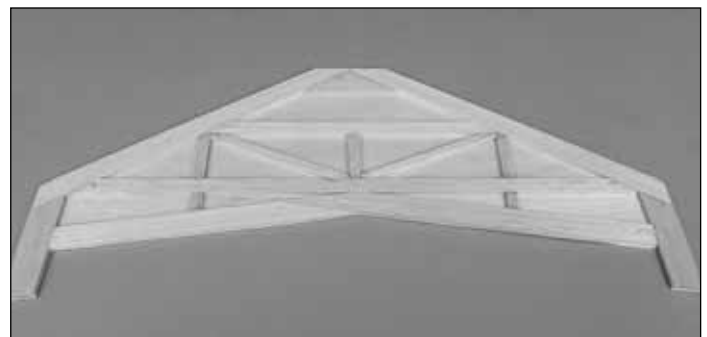

3. Cut the excess sheeting from the stab. Save the remainder for the fin.



4. Sheet the other side of the stab the same way. Sheet both sides of the fin with the leftover sheeting.

Note: Give the CA ample time to harden before lifting the assembly off the building board. It is essential to get a secure and uniform bond between the stab sheets and the stab framework, especially in the center.

Build the Rudder and Elevators

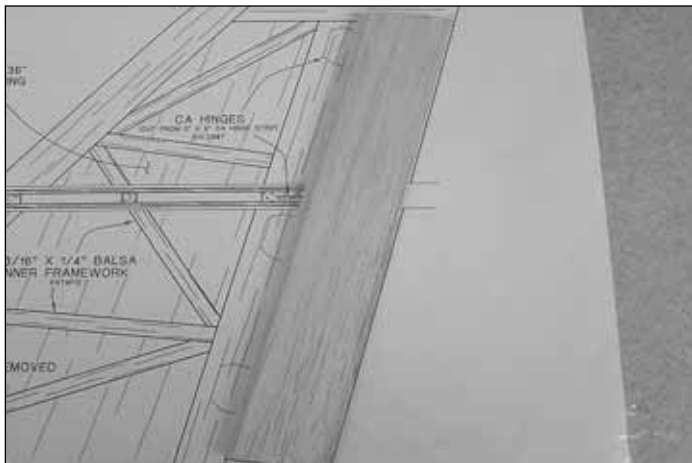

1. Cut the rudder to the length shown on the plan from the shaped 25" [635mm] balsa rudder/elevator stick. (**Note:** The elevators are also cut from this stick, so be careful with the measurements.) Remember, measure twice, cut once!



2. Use a Great Planes Precision Hinge Marking Tool or measure and mark a centerline on the **LE** of the rudder and the **TE** of the fin.

3. Mark the hinge locations where shown on the plan.

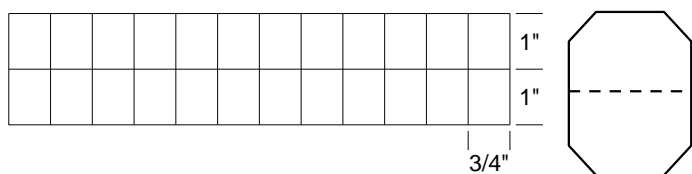

4. Cut nine 3/4" x 1" [20 x 25mm] hinges for the elevators and rudder from the supplied 2" x 9" [51 x 230mm] **CA hinge strip**, and then snip off the corners so they go in easier.



5. Using the centerlines as a guide, cut the hinge slots where shown on the plan with a Great Planes Slot Machine,

then proceed to step 7. If you do not have a Slot Machine, or cannot access one of the hinge locations with it, you will need to follow the procedure for cutting hinge slots with a hobby knife and #11 blades.

Notes about CA hinges: This kit is supplied with CA hinge material consisting of a 3-layer lamination of Mylar and polyester specifically made for hinging model airplanes. When properly installed, this type of CA hinge provides the best combination of strength, durability, and easy installation. It is essential to install them correctly. Follow the hinging instructions in this manual for the best result. The techniques shown have been developed to ensure thorough and secure gluing.



HOW TO CUT HINGE SLOTS WITH A HOBBY KNIFE

When using a hobby knife to cut hinge slots, one of the most common mistakes made by modelers is making the slots too tight. This restricts the flow of CA to the back of the hinges. Another mistake made when installing hinges is not using enough glue to fully secure the hinge over its entire surface area. This will result in hinges that are only *tack glued*. Follow these steps to cut hinge slots with a hobby knife:

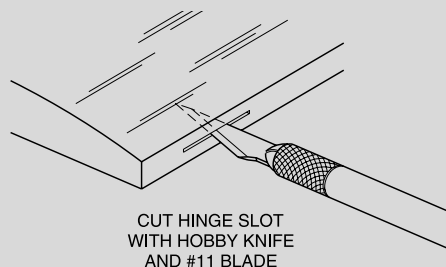

A. Using the centerline as a guide, cut one of the hinge slots in the fin or rudder where shown on the plan with a #11 blade. Begin by cutting a shallow slit. Make three or four cuts along the same line, going slightly deeper each time. As you proceed, be certain to go **straight** into the wood and move the knife from side-to-side until the blade has reached the correct depth for the hinge.

B. Test fit a hinge into the slot. If the hinge does not slide into the slot easily, remove the hinge and reinsert the knife, working the blade back and forth a few times to provide more clearance (it's the back edge of the blade that does the widening).

C. Cut the rest of the hinge slots the same way.

6. Temporarily join the elevators to the stab with the hinges, adjusting any hinge slots if necessary so they all align. **Do not glue in the hinges until you are instructed to do so.**

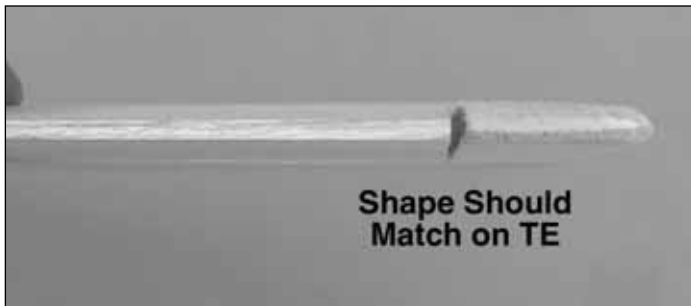

7. Sand the stab and fin tips to match the taper of the elevators and rudder.

Finish the Tail Surfaces

1. Shape the leading edge of the elevators and rudders to a "V" as shown on the plans.
2. Use a bar sander and 150-grit sandpaper to round the tail surfaces as shown on the plan.

BUILD THE WING

Build the Wing Panels

Note: Wing construction is engineered to provide a straight-and-true wing panel with minimum effort. To do so, the building sequence and pieces are different from what you may be accustomed to. Be sure to read all steps carefully and pay particular attention to instructions of when and where to apply adhesives.

Note: The wings are built upright over the plan. You may build both wing panels at once following the instructions if you have space to do so.

1. Lay the **right wing panel** plan on a flat building board and cover with wax paper or plan protector.



2. Cut the **bottom main wing spar** to the length shown on the plan from a 1/8" x 1/2" x 36" [3 x 13 x 910mm] basswood stick. Pin the spar to the plan.

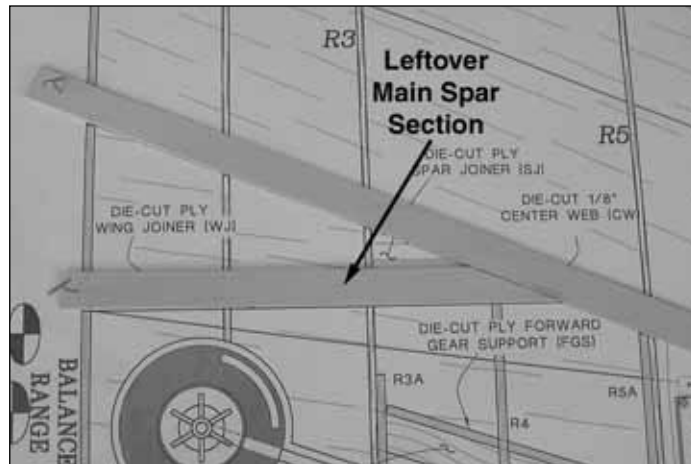

3. Cut the **bottom aft wing spar** from the leftover 1/8" x 1/2" [3 x 13mm] basswood stick.

4. Lay out the die-cut 3/32" [2.4mm] **balsa wing ribs** R2 through R10 in the general area of their location on the plan. Rib **R4** will be installed in the last step and can be set aside for now.

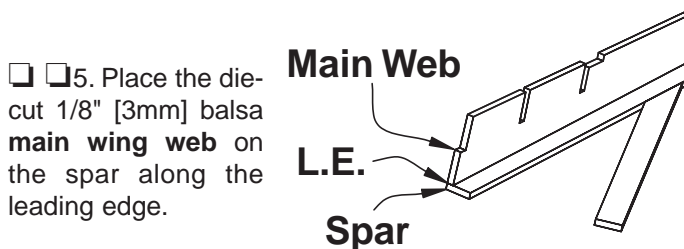

5. Place the die-cut 1/8" [3mm] **balsa main wing web** on the spar along the leading edge.

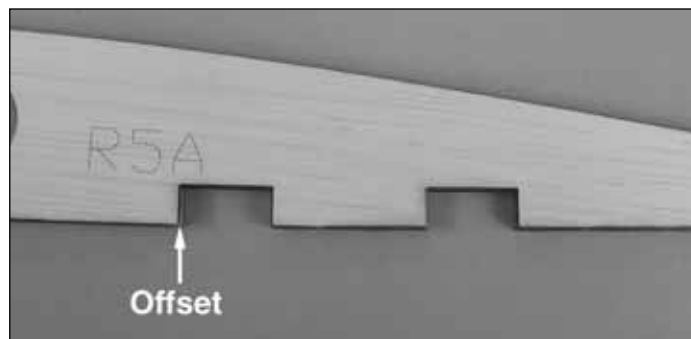
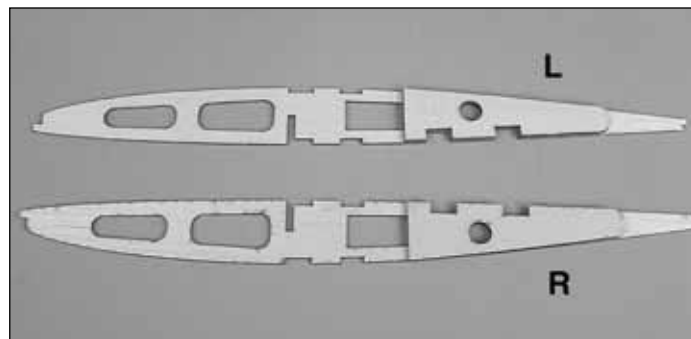

6. Use the 1/2" [13mm] holes to align the die-cut 1/8" [3mm] plywood rib doublers **R3A** with ribs **R3**. Glue in place with medium CA. Make a right and a left. Note: There is a slight offset in the slots on the ribs as compared to the doubler. This is normal.

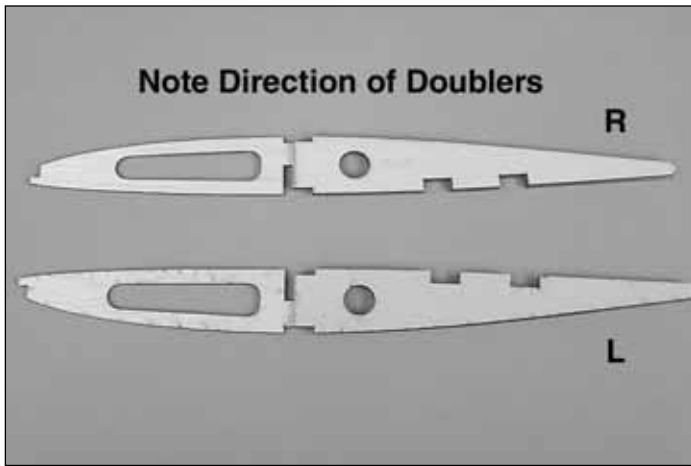

7. Use the 1/2" [13mm] holes to align the die-cut 1/8" [3mm] plywood rib doublers **R5A** with ribs **R5**. Glue in place with medium CA. There will be an offset built in just like in the previous step.

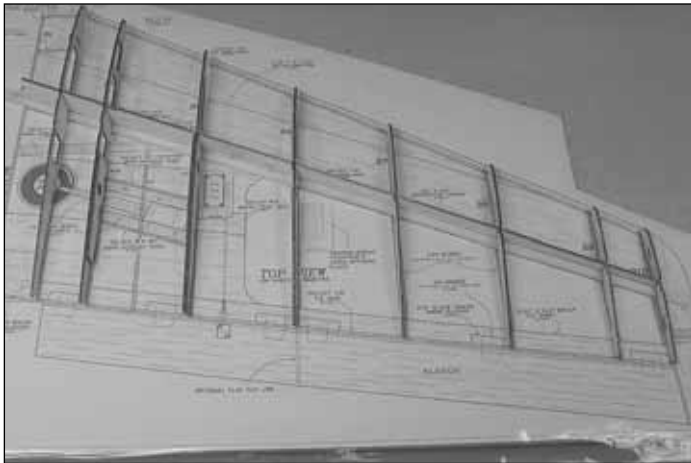

8. Test fit ribs R2 through R10 on the main wing spar and web. **DO NOT** install R4 until instructed to do so.

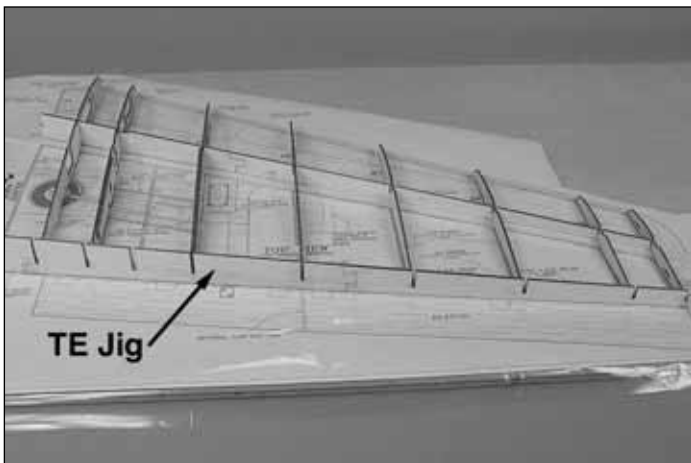

9. Test fit the die-cut 1/8" [3mm] balsa **TE Jig**. Insert the wing ribs into the slots on the TE jig and align with the plan.



10. Test fit the die-cut 1/8" [3mm] balsa **LE Jig**. Insert the wing ribs into the slots on the LE jig and align with the plan.

11. Once you've finished test fitting and are happy with the fit, begin gluing using thin CA. Weigh down the TE to keep it flat on the work bench. Starting at R2, glue the ribs first to the TE and then to the LE. Ensure each rib is pressed all the way down into the TE slots and the LE is pressed all the way down onto each rib. After the LE jig and TE jig have been glued, glue the center spar and center web into place using thin CA.

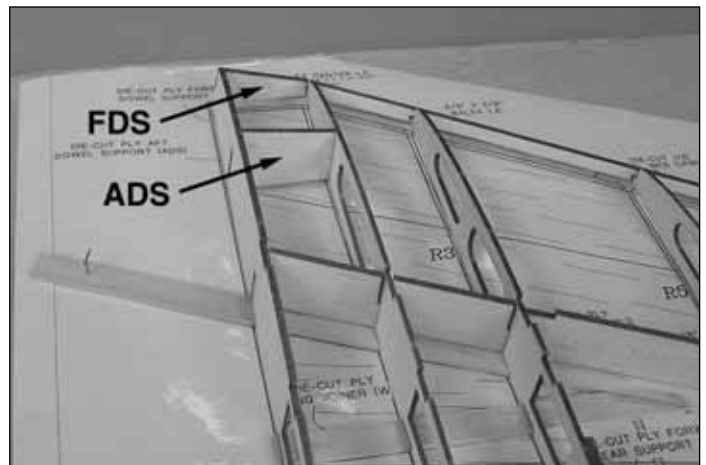

12. Test fit R1, the die-cut 1/8" [3.2mm] plywood **forward dowel support (FDS)** and the die-cut 1/8" [3.2mm] plywood **aft dowel support (ADS)**.

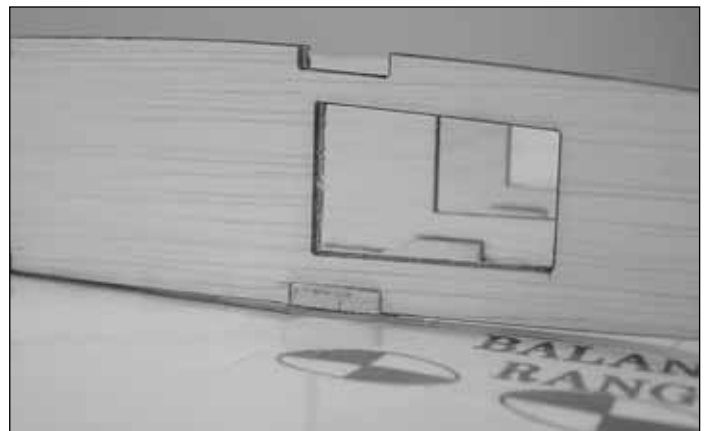

13. Make sure the bottom aft wing spar is pressed all the way up into the slot in R1 and glue in place.

□ □14. Use a straightedge to make sure R1 is straight from the LE to the TE and glue in place with thin CA. **Note:** R1 will have a few degrees of tilt. This is normal.



□ □15. Insert the die-cut 1/8" [3.2mm] balsa **center web (CW)** into the slot in R1 until the notches line up with the ribs. Twist into position.



□ □16. Install the die-cut 1/8" [3.2mm] plywood **spar joiner (SJ)** **without tabs** into the area marked on the plan. Glue in place using thin CA.



□ □17. Test fit the 1/8" [3.2mm] die-cut ply **spar joiner (SJ)** **with tabs**. Glue in place with medium CA.

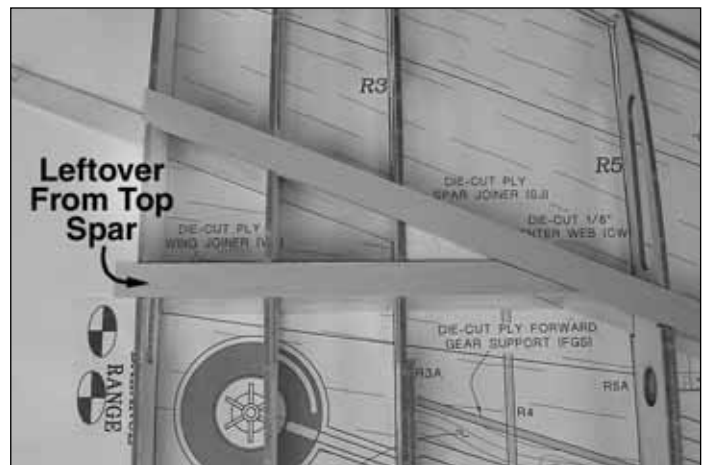
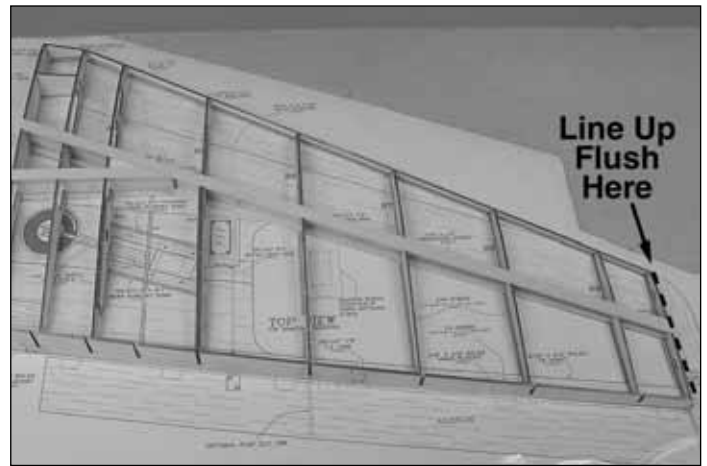

□ □18. Test fit the top main wing spar and the top aft wing spar. Glue in place with medium CA.

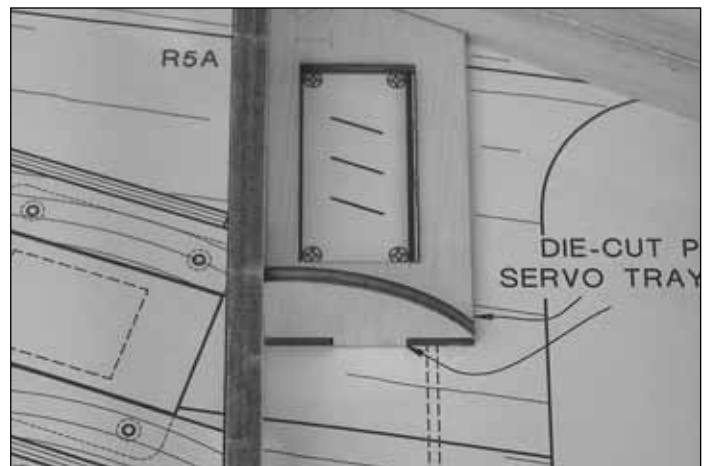

□ □19. Locate the die-cut 1/8" [3mm] ply **servo tray** and **servo tray brace**. Align the servo tray with the plan and glue in place using thin CA. Be sure the servo tray is even with the rib on the bottom of the wing. **Note:** If building flaps install the aileron servo tray the same way.

Sheet the Wing Panel Top

□□□□ 1. Glue two 3/32" x 3" x 36" [2.4 x 75 x 910mm] balsa sheets together to make one 3/32" x 6" x 36" [2.4 x 75 x 910mm] LE sheet.

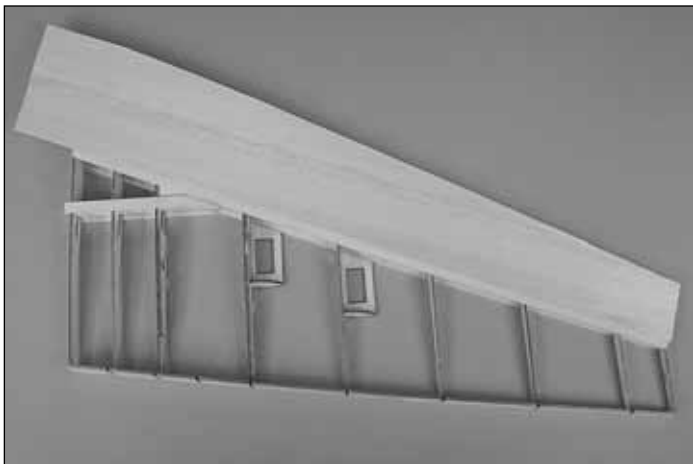

□□□□ 2. Align the edge of the LE sheeting with the center of the top wing spar. Trim off the excess sheeting, leaving about 1/4" [6mm] of over-hang on the wing LE and ends.

□□□□ 3. Soften the sheeting by rubbing warm water into the side of the wood **not** being glued. This will allow the balsa to conform to the shape of the wing when it is rolled.

□□□□ 4. Apply a thick bead of medium CA down the center of the top wing spar and down each rib toward the leading edge of the wing. Glue the sheeting to the LE.

□□□□ 5. Align the edge of the sheeting up with the middle of the wing spar and, working quickly, roll the sheet down towards the leading edge. A long sanding bar or straight edge will help you apply even pressure.

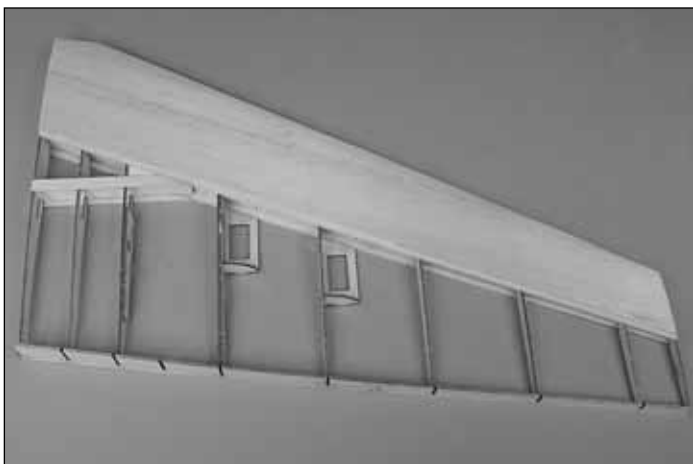

□□□□ 6. Once the glue has set, trim the sheeting to match the shape of the wing.

□□□□ 7. Flip the wing over and repeat steps 1-6 to sheet the wing panel bottom from the main wing spar to the LE.

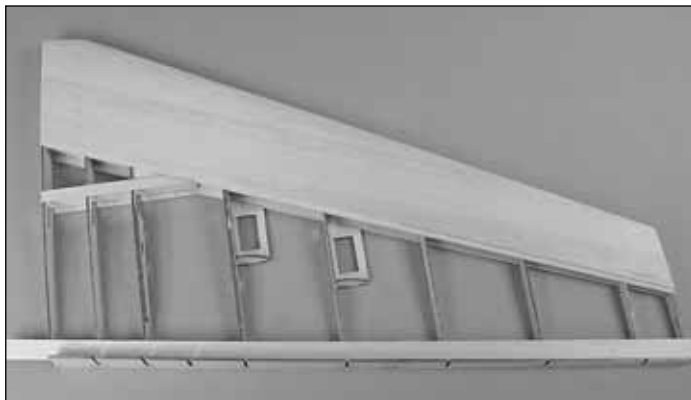

□□ 8. Locate two of the 3/32" x 3/4" x 30" [2.4 x 19 x 760mm] balsa **TE sheets**. Test fit the TE sheeting and mark how far it reaches up each rib so you know where to run the glue. Do this for the top and bottom of the wing panel.

□□ 9. Apply a thick bead of medium CA on each rib and the edge of the TE sheeting that rests against the TE Jig. Glue the top and bottom TE sheeting in place.



□□ 10. Sheet the top of the wing center section with 3/32" x 3" x 36" [2.4 x 75 x 910mm] balsa sheets. The center section sheeting rests flush against the TE sheeting and should be trimmed just short of R6 to allow room to trim the sheeting to match the plan. Glue with medium CA. The second sheet should rest flush against the first sheet and is glued in the same manner as the first. Do not sheet the bottom center section until instructed to do so.



□ □11. Finally, fill in the last portion of center sheeting with a leftover piece of 3/32" [2.4mm] sheeting.

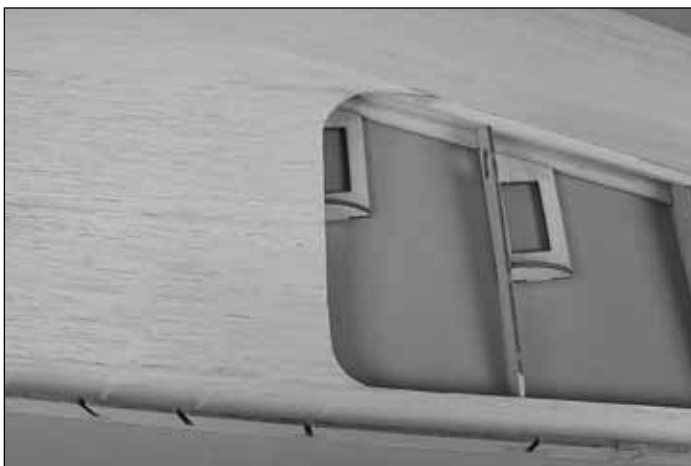

□ □12. Once the CA has fully hardened, trim the top center section sheeting to match the inside curves shown on the plan.



□ □13. Locate the 3/32" x 1/4" x 30" [2.4 x 6 x 760mm] balsa **cap strips**. The cap strips are cut to fit the rib between the LE sheeting and the TE sheeting as shown, and are centered on the rib. Pay special attention to the cap strip on R10. It is not centered like the other cap strips, but is glued to one side flush with the wing tip.



Hint: For a guide to trimming the sheeting, we used a **Hobbico® Cloth Retractable Tape Measure** to get the curve angles for the inner cutout. It closely matches the shape shown on the plan and will give you a nice rounded corner that can easily be cut out. Lining up one edge of the Hobbico tape measure with rib R6 will also give you a close measurement to the actual plan cut out of the sheeting.



A single-edge razor blade works well for cutting the straight lines needed to make the cap strips match the sheeting.

At this time you should start building the other wing panel. Follow the above instructions to this point.

Install the Landing Gear Rails

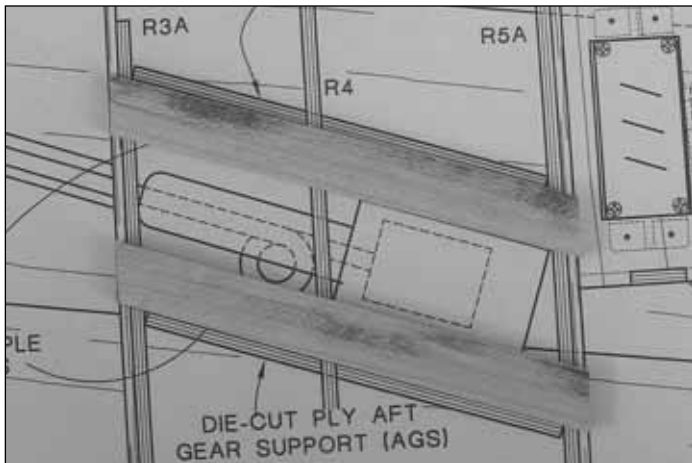

1. Locate the 1/4" x 1/2" x 24" [6 x 13 x 610mm] maple **landing gear rail**. Cut two landing gear rails to match the plan. Set the leftover maple railing aside for use on the left wing panel.

2. Locate the die-cut 3/32" [2.4mm] plywood **FGS (forward gear support)** and **AGS (aft gear support)**.

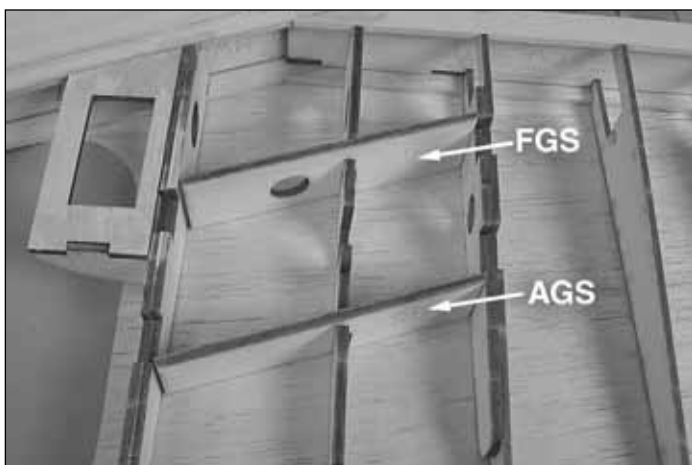

3. Slide R4 into position with AGS and FGS. The two gear supports will help you align R4 according to the plan.



4. Test fit the two maple landing gear rails.

5. When everything is in place and you are happy with the test fit, glue AGS, FGS, and R4 in place with medium CA. Do not glue the maple landing gear rails at this time.

6. Once the CA has hardened, remove the two gear rails. Mix a generous amount of 30 minute epoxy. Liberally coat the side of the gear rail that touches the gear support and to each slot the gear rail rests in. Press the gear rail into place and wipe the excess epoxy away with a paper towel and alcohol. Do this for both rails. Allow time for the epoxy to cure before handling.

7. Locate the 3/8" x 3/8" x 30" [9.5 x 9.5 x 760mm] balsa **hinge block stick** and cut it into six (6) 1-1/2" [38mm] segments as shown on the plan.

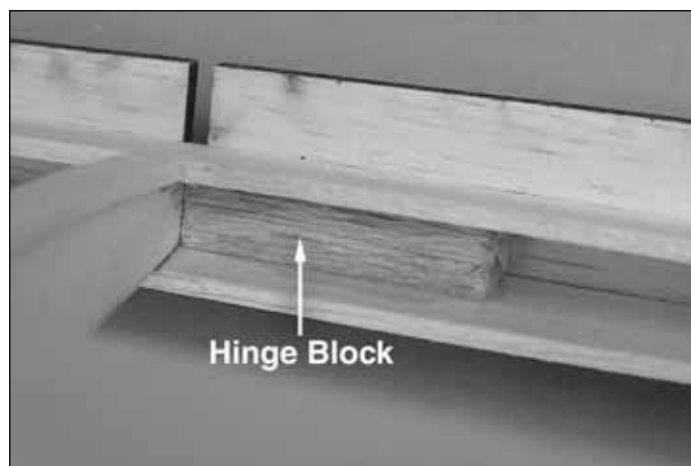

8. Glue each hinge block in place according to the plan. You may need to shape the blocks to fit snugly.

Begin Shaping the Wing



1. Glue the 3/8" x 5/8" x 30" [9.5 x 15.9 x 60mm] balsa **leading edge (LE)** in place using medium CA. Trim the ends to match the plan.

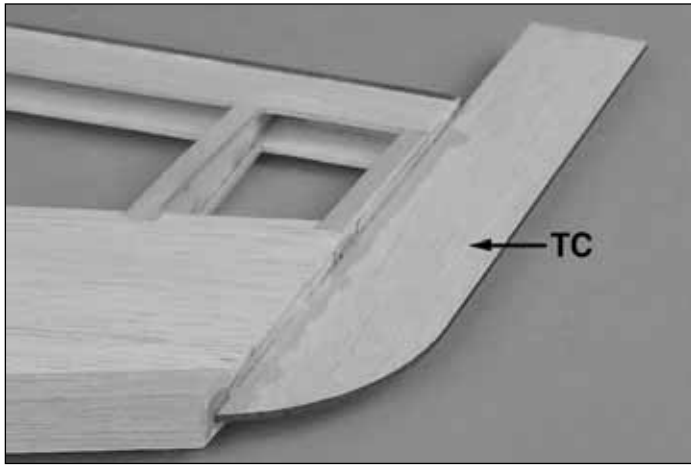

□ □2. Glue the die-cut 3/32" [2.4mm] balsa **wing tip center (TC)** into position. Be certain it is centered and perpendicular to R10.

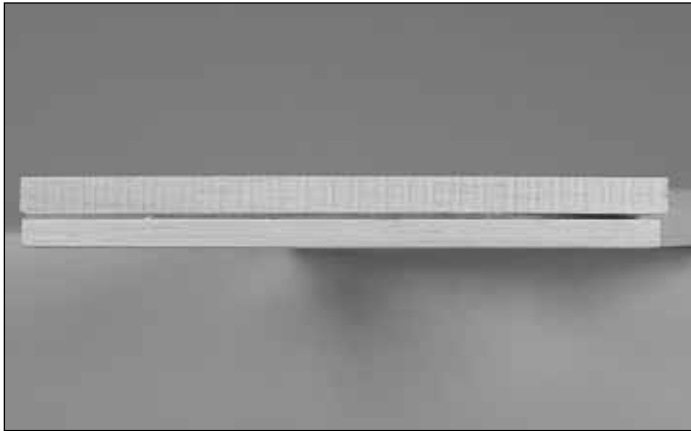

□ □3. Locate the 3/8" x 3" x 24" [9.5 x 75 x 610mm] balsa **wing tip stick** and the 1/2" x 3" x 24" [13 x 75 x 610mm] balsa **wing tip stick**. Cut a piece from each stick to match the plan for the wing tips. **Note:** The 1/2" [13mm] stick will be on the top of the wing; the 3/8" [9.5mm] stick will be glued to the bottom of the wing tip. Trim to the approximate shape of the wing tip and glue in place. Save all leftover balsa from the 3/8" [9.5mm] stick. You will need it after joining the wing.

□ □4. Shape the LE as shown on the plan.

Install the Retracts

Note: This section applies only to those modelers installing pneumatic retracts. If you are installing **fixed gear**, proceed to "**Install the Fixed Gear**" on page 18.

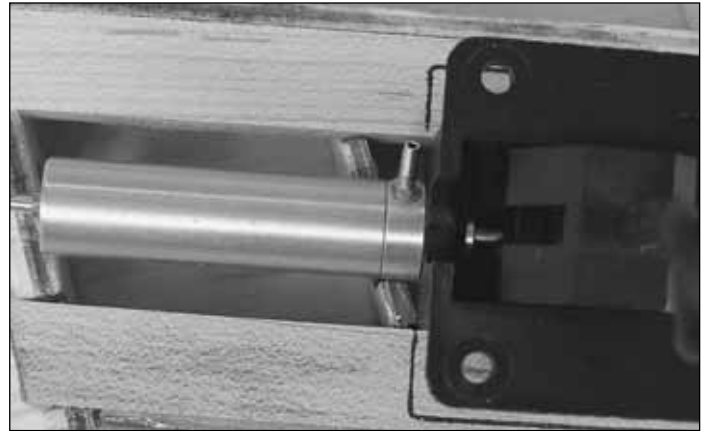

□ □1. Test fit the retract between the landing gear rails. You may have to trim R4 a little to allow the retract to seat properly. The landing gear rails may also need a slight sanding to allow the base of the retract to fit. Note how the retract is inserted. This allows for the air fitting to be accessed through the hole in R3.

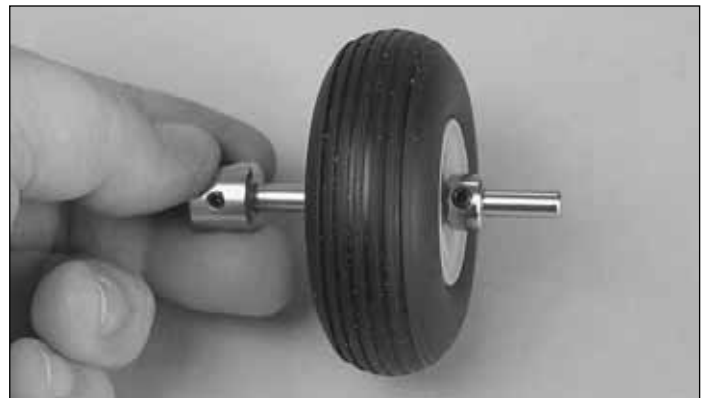

□ □2. Slide a 2-1/4" **wheel** onto an **axle** followed by a 5/32" [4mm] **wheel collar**. Apply a small drop of general purpose oil to the axle. Tighten the set screw on the wheel collar to hold the wheel in place. Using a file or rotary tool, grind a flat spot onto the axle where the set screw touches. This helps reduce the chance of the wheel collar slipping.

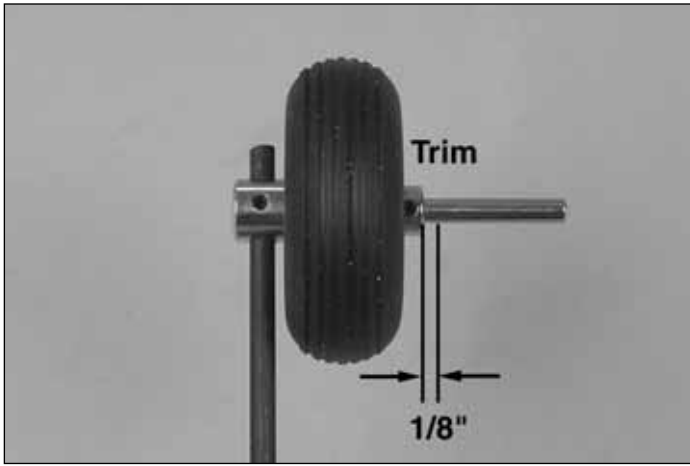

□ □3. Using a metal saw or rotary tool with cutting wheel, trim the axle 1/8" [3mm] from the wheel collar.

□ □4. Slide the wheel/axle assembly onto the strut.

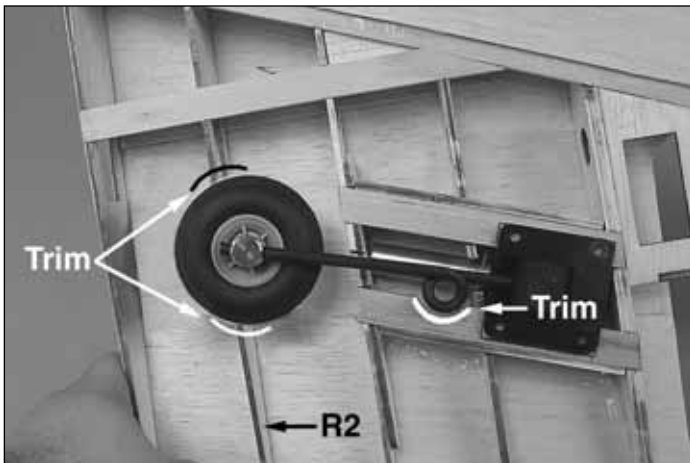

□ □5. Note the position of the wheel on the plan. Lower the strut with the wheel/axle assembly in place. Slide the axle on the strut until it is in the location shown on the plan. Grind a flat spot onto the strut where the set screw touches. Tighten the set screw on the axle to hold it in place. Trim off the excess strut, leaving approximately 1/8".

□ □6. Mark the location on R2 where the wheel touches. Trim R2 to allow the wheel to fully retract inside the wing. It may also be necessary to trim R3 to allow the strut to fully retract.

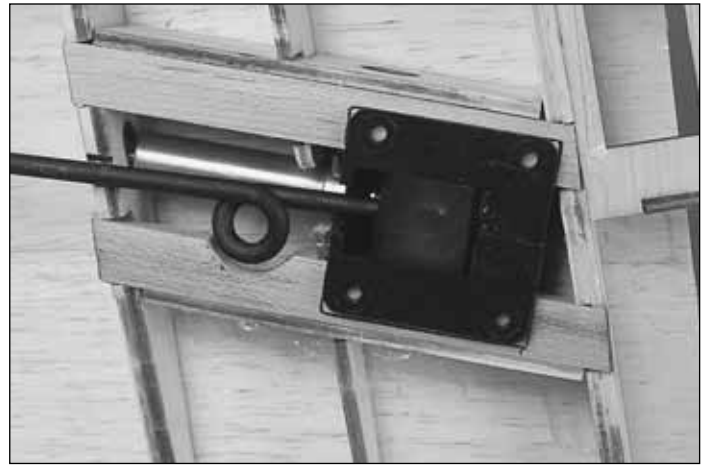

□ □7. Once the retract is fitted, mark the holes for the mounting screws. Drill 3/32" [2.4mm] holes for the retract mounting screws, or as your retract manufacturer suggests.

Install the Fixed Gear

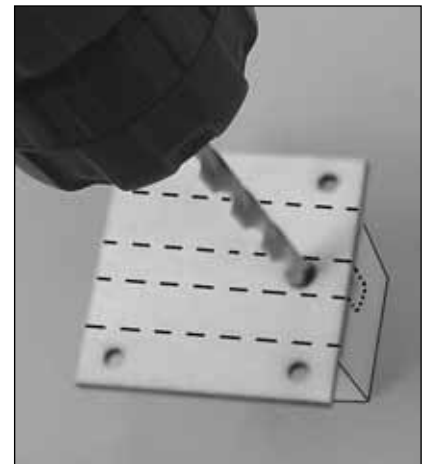
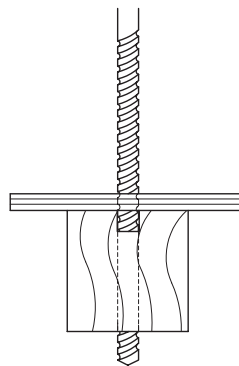
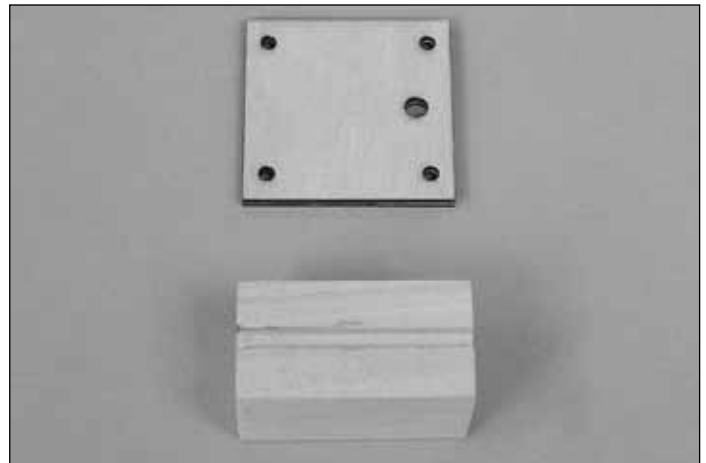

□ □1. Locate the 2-3/4" x 1" x 5/8" [70x25x16mm] basswood **fixed gear block** and the die-cut 1/8" [3.2mm] plywood **fixed gear plate**. Align the end of the plate with one end of the block. Drill a 5/32" [4mm] hole through the block to fit the landing gear wire using the hole in the fixed gear plate as a guide.

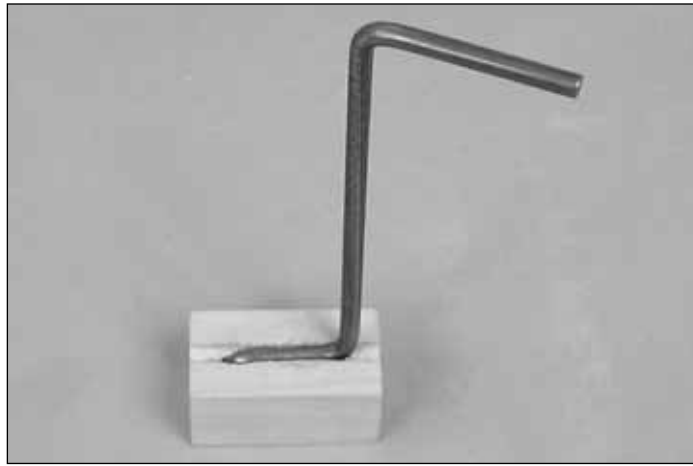

□ □2. Insert the wire as shown. It may be necessary to deepen the groove in the fixed gear block to allow the wire to sit flush with the top of the gear block.

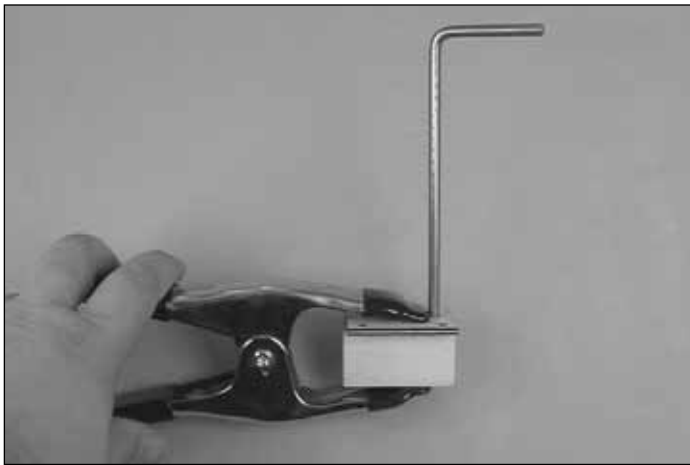

□ □3. Mix a small amount of 30-minute epoxy. Epoxy the fixed gear plate to the gear block and clamp together. Allow the epoxy to fully cure.



□ □4. Test fit the fixed gear block in the wing in the same location as the retract mount, as shown on the plan. Drill 5/32" [4mm] holes for mounting the fixed gear. Some sanding may be necessary to get a good fit between the rails.

Both wing panels should now be ready to be joined following all previous steps.

Join the Wing Panels

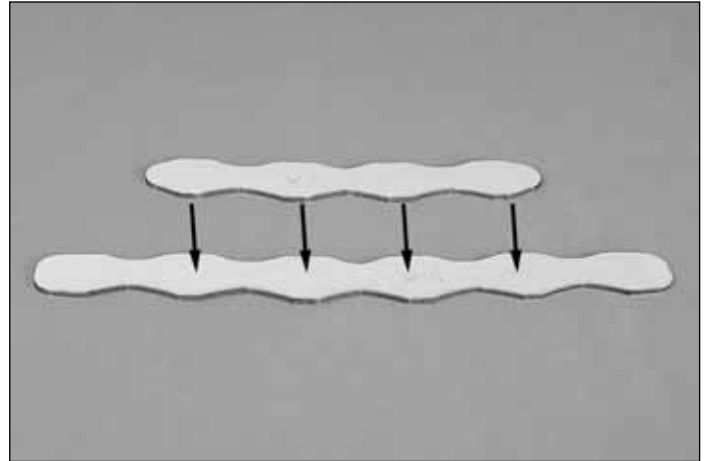

□ 1. Locate the two die-cut 1/8" [3mm] ply **wing joiners**, **WJ1** and **WJ2**. Use 30-minute epoxy to glue the joiner together.

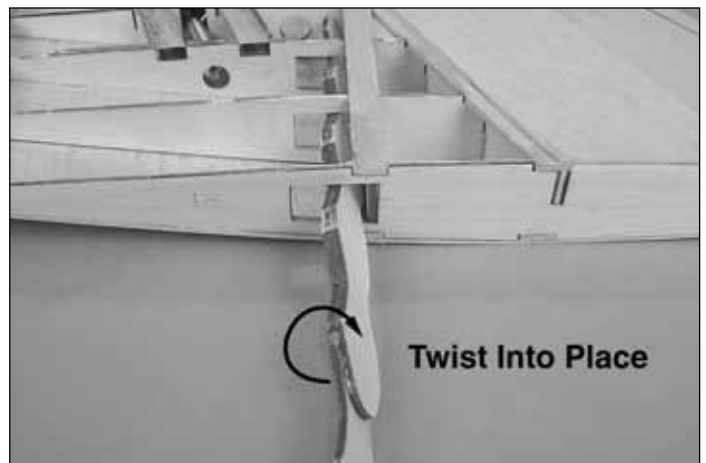

Twist Into Place



□ 2. Test fit the wing panels with the wing joiner. Note the direction of the "V-shape" of the wing joiner. The bottom of the "V-shape" points to the bottom of the wing. Insert the joiner by sliding it in at an angle and twisting into place.



❑3. Mix 1/4oz of 30-minute epoxy. Liberally coat the root rib of one wing half, half of the wing joiner, and center web with epoxy. Insert the joiner and clamp in place against the center web (CW). Be sure there is plenty of epoxy coating the wing joiner and center web; it should ooze out of everywhere when the clamp is compressed.

❑4. With one side of the joiner clamped in place, coat the center web in the other wing half and the wing joiner. Twist together the two wing halves.



❑5. Clamp the wing joiner in place. Make sure the wing is straight and the wing roots meet with little or no gap. Clean up excess epoxy with a paper towel and denatured alcohol. When the epoxy has fully cured, remove the clamps and fill in any gaps with more epoxy.



❑6. Cut a 2" x 6" [50 x 150mm] block from leftover 3/8" [9.5mm] balsa from the wing tip blocks. This is the **center LE**. Glue it to the LE center of the wing and shape it to match the wing.

❑7. Cut the shaped balsa **bolt support** to make two supports. Trim each to match the plan and glue in place with medium CA.

Sheet the Bottom of the Wing

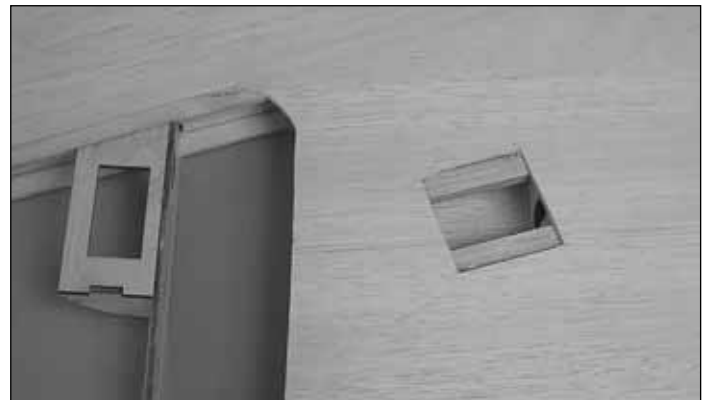

❑❑1. Sheet the bottom wing in the same manner as the top, one half at a time. You will need to make a cutout for the landing gear in the sheeting. The way we did this was to install the first section of sheeting flush with the TE sheeting, then position the gear. Trace the outline of the gear onto the sheet. This way, you can align the plate with the outline when the second sheet is glued and trace the remainder of the cutout. Do not glue the sheeting to the areas to be cut out.



❑❑2. If you installed the flap servo tray, sheet it at this time. Cut a piece of sheeting flush with the LE sheeting that covers the tray. Glue a cap strip from the bottom of the servo tray to the TE sheeting as shown.

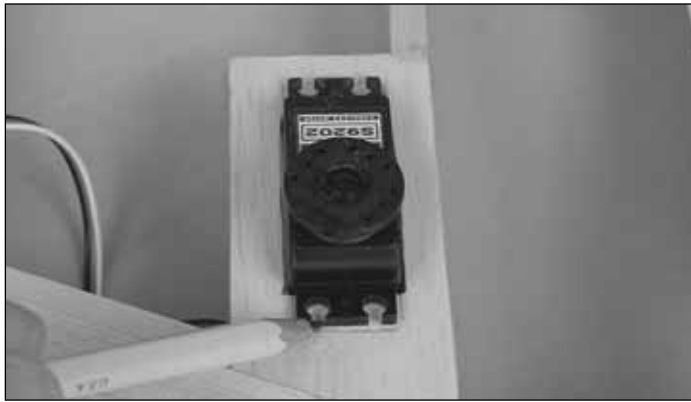

□ □3. Cut out the sheeting over the servo trays. Slide a servo into the tray and trace the outline of the servos' tabs. Remove the servo and then trim the sheeting to allow the servo to sit down into the cutouts.

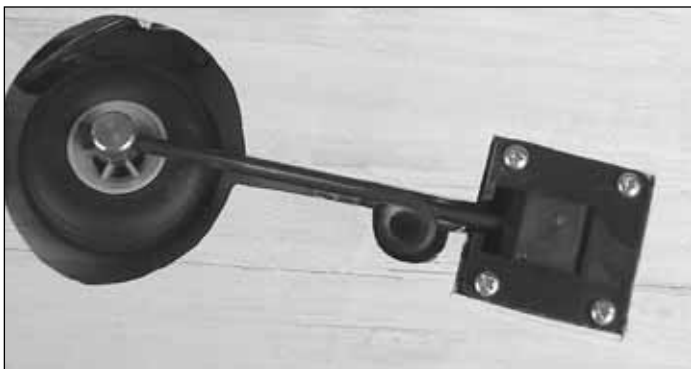
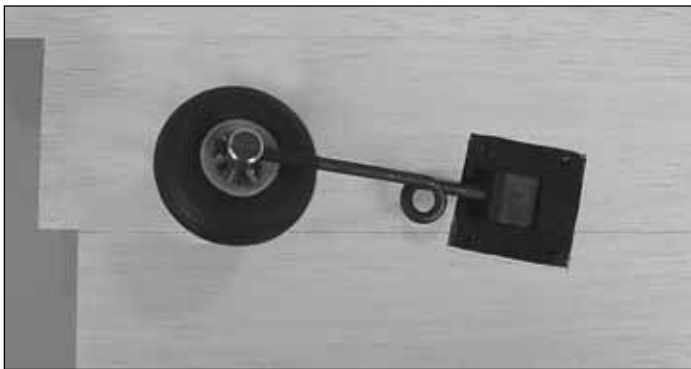

□ □4. If you installed retracts, trim the sheeting to accommodate the retract. Install the retract and lower the strut. Mark the sheeting where the strut and the wheel need to pass. Remove the sheeting with a sharp hobby knife. Cut 1/8" [4mm] clearance around the wheel so it doesn't contact the sheeting.

Install the Ailerons

□ □1. Locate the two shaped 25" [635mm] balsa **ailerons**. Shape the LE for each side to match the plan. *If you are installing flaps, you will need to cut the aileron at the location shown on the plan.* **Note:** The flap hinges are slightly above the centerline due to their shape. Refer to the plan.

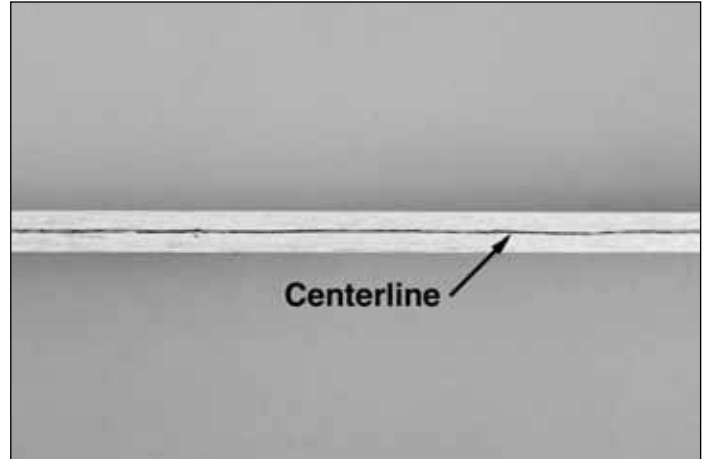

□ □2. Mark the centerline on the LE of the aileron and TE of the wing as shown on the plan. Cut the hinge slots for the ailerons and flaps if used.

□ □3. Cut eight hinges from the supplied hinge material and temporarily mount the ailerons (and flaps if installed) to the wing.

□ □4. With the control surfaces in place, sand the wing tips to match the shape of the ailerons.

Finish Shaping the Wing

□ □1. Using a bar sander and 200-grit sandpaper, round all edges and shape the wing to match the plans.

□ □2. Carefully trim the TE jig even with the sheeting on the bottom of the wing.

BUILD THE FUSELAGE

Assemble the Fuse Formers and Sides

Note: We have removed the parts from the plan for clarity in the some of the photos.

□ □1. Clear your building surface; you will need a lot of room for the fuse plan. Pin the side view to your building board and cover with wax paper or plan protector.

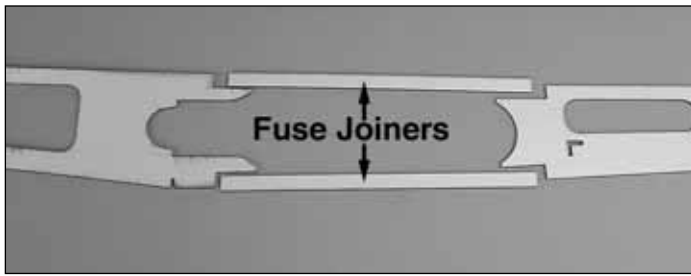

2. Locate the die-cut 1/8" [3mm] ply **front fuse side (FFS)**, the die-cut 1/8" [3mm] ply **aft fuse side (AFS)**, and two of the die-cut 1/8" [3mm] **fuse joiners (FJ)**.

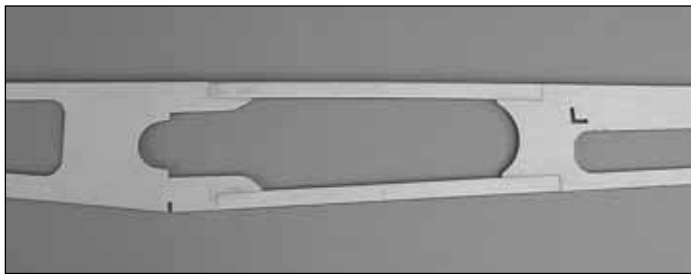

3. Lay the parts over the plan and pin them in position.

4. Glue the parts together, making sure there is a straight line between AFS and FFS.

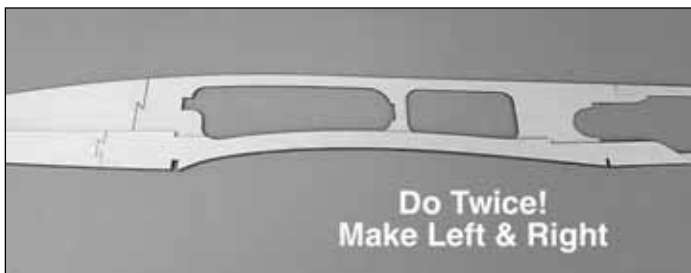

5. Locate the die-cut 1/8" [3mm] ply **fuse doublers (FD)**. Line up the doubler to the inside edge of the fuse side. Glue in place using medium CA.

6. Repeat steps 1-5 to build the other side of the fuselage.

7. Next you will assemble the fuse top, so you will need to position the plan so the bottom view is over the building board.
Note: The fuselage is built upside-down over the plans.

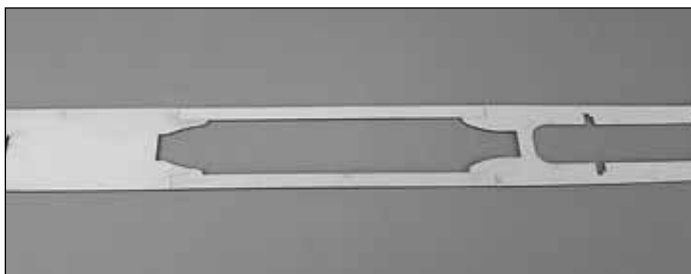

8. Locate the die-cut 1/8" ply **aft fuse top (AFT)** and die-cut 1/8" ply **forward fuse top (FFT)** pieces and pin them in place over the plan. The last two FJ pieces will join AFT and FFT together like you did with the sides. Glue all the pieces together using thin CA at the joints. Leave the fuse top pinned to the plan.

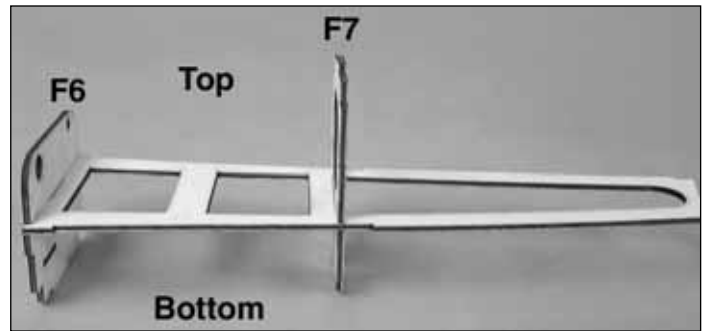

9. Locate the die-cut 1/8" [3mm] ply **servo tray (ST)**, **former F6**, and **former F7**. Test fit the pieces as shown. Place the assembly over the fuse top in the position shown on the plans and bring the fuse sides up meet F6 and F7. There will be notches on the fuse sides to line it up. Make sure the two formers are vertical and all the joints fit together with minimal gaps. When satisfied with the fit, glue in place with medium CA.

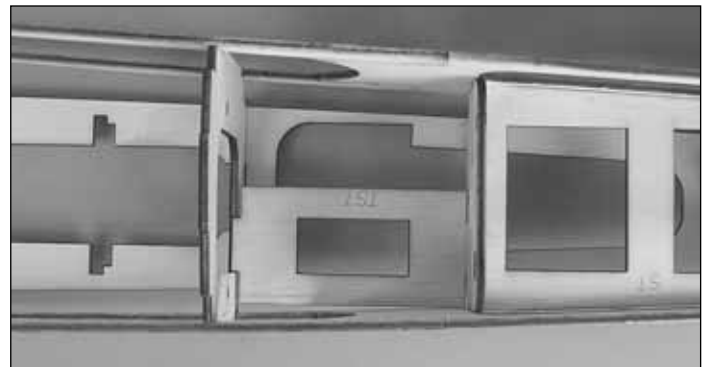

10. Locate die-cut 1/8" ply **former F5** and the die-cut 1/8" ply **throttle servo tray (TST)**. Fit these pieces as shown and glue together. Ensure F5 remains vertical.

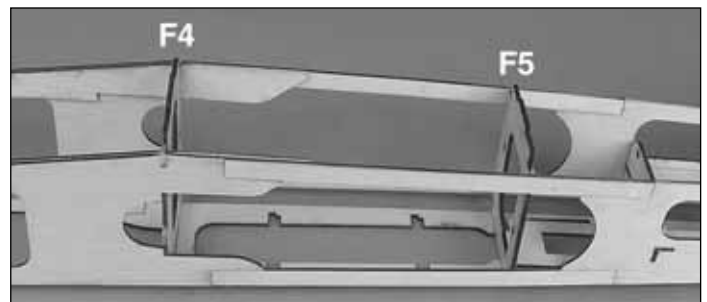

11. Test fit, then glue in place, die-cut 1/8" plywood **former F4**.

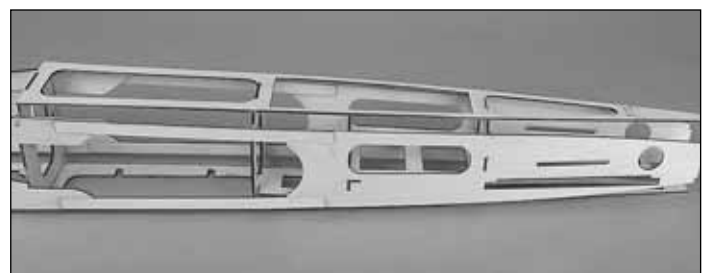

12. Now that you have formers F4 through F7 in place and both servo trays installed, you can glue the die-cut 1/8" ply **fuse bottom** in position.

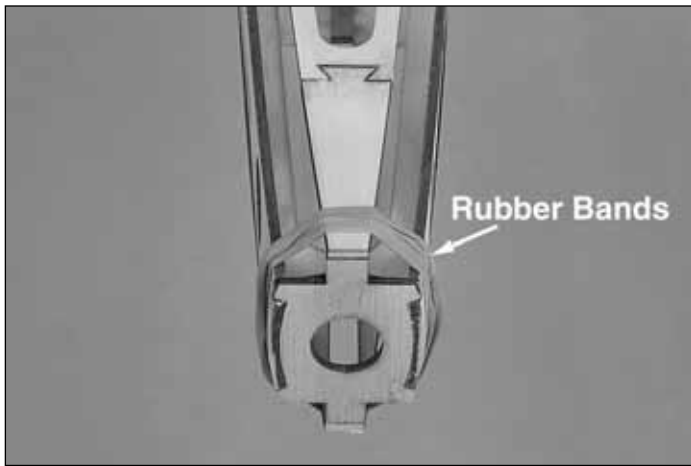

❑ 13. Test fit former **F8**. Notice the sides of the fuse will need to bend slightly to conform to F8. Wet the ends of the fuse sides and wrap F8 with rubber bands as shown. The water will allow the fuse sides to conform to F8.

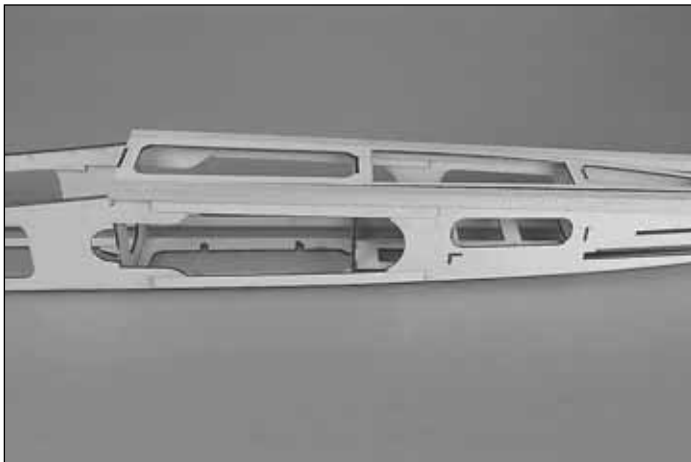

❑ 14. Locate four (4) of the 1/2" x 1/2" x 30" [13 x 13 x 762mm] balsa **fuse corners**. The span between F4 and F7 is flat. Weight down the fuselage at F4 and F7. Working on the bottom of the fuselage first, glue both fuse corners to F4 first, then glue both corners to F7. This helps eliminate any tendencies to twist the fuselage.

❑ 15. Glue the sides of the fuse to the fuse corners between F4 and F7.

❑ 16. Once the sides and bottom corners are securely glued in place between F4 and F7, you can then glue the corners to F8. Lay a bead of medium CA where the corner will sit in F8, then wrap your hand around the tail and both corners and squeeze the corners into place. Allow the glue to harden while holding it in place. Go back after gluing the corners into F8 and glue the sides in place using thin CA.

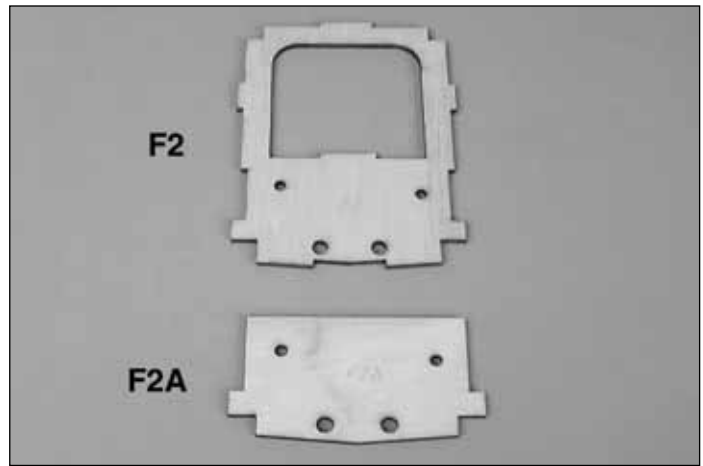

❑ 17. Glue **F2A** to the front of **F2** with medium CA. Align the pieces using the factory-cut holes. This assembly is now **F2**.

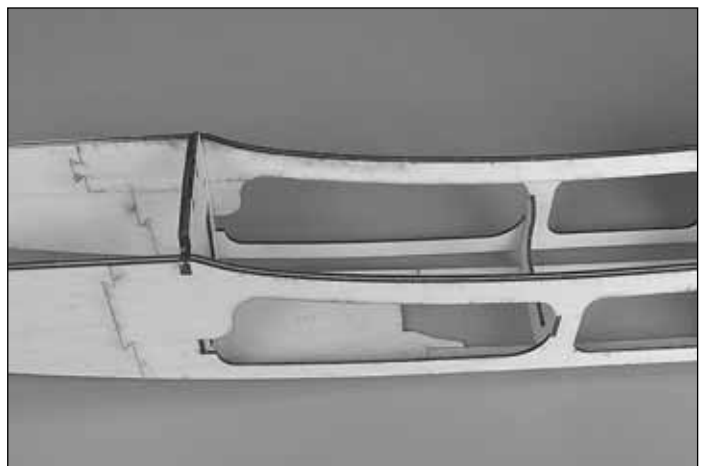

❑ 18. Glue formers F2 and F3 in place using thin CA.

Install the Firewall

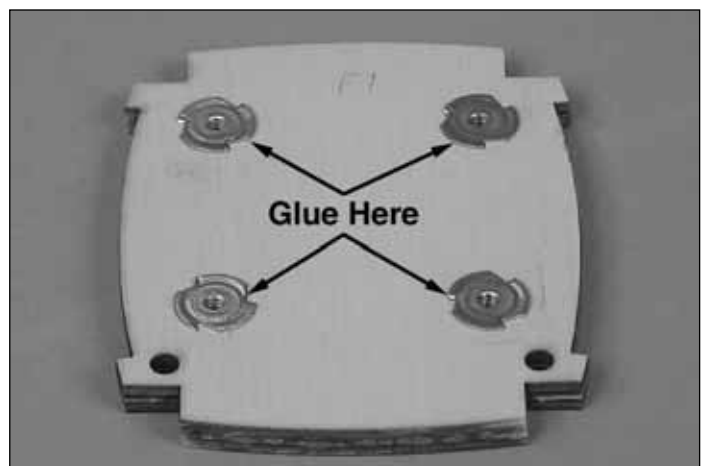

❑ 1. Use 30-minute epoxy to glue together the two die-cut 1/8" plywood formers F1. From now on, this assembly will be referred to as the firewall. Install four 6-32 blind nuts in F1. Apply a small amount of epoxy or CA to the back of the blind nuts to hold them in place.

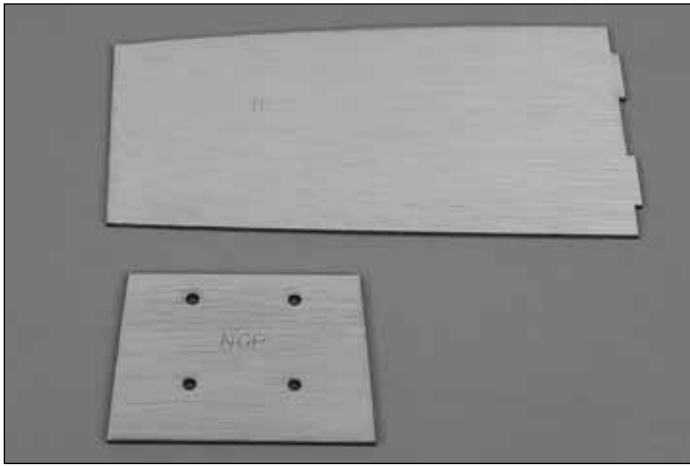

❑2. If using fixed gear, skip to step 4. If installing retracts, you will need to glue the die-cut 1/8" [3mm] plywood **nose gear plate (NGP)** to the 1/8" [3mm] **tank floor (TF)**. Drill four 5/32" [4mm] holes through the punchmarks in the NGP.

❑3. Drill four 5/32" [4mm] holes and install 6-32 blind nuts on the back of the tank floor. The back is the side you glued the NGP to.

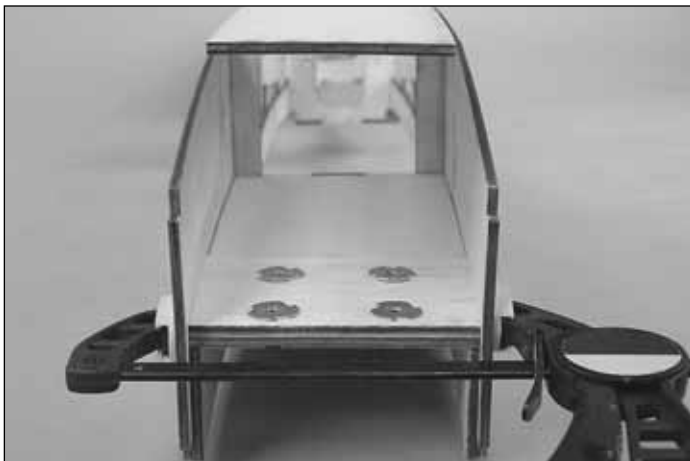

❑4. Test fit the tank floor. Use a clamp or rubber bands to hold the fuse sides together, pinching the floor in place. Glue the floor in place.

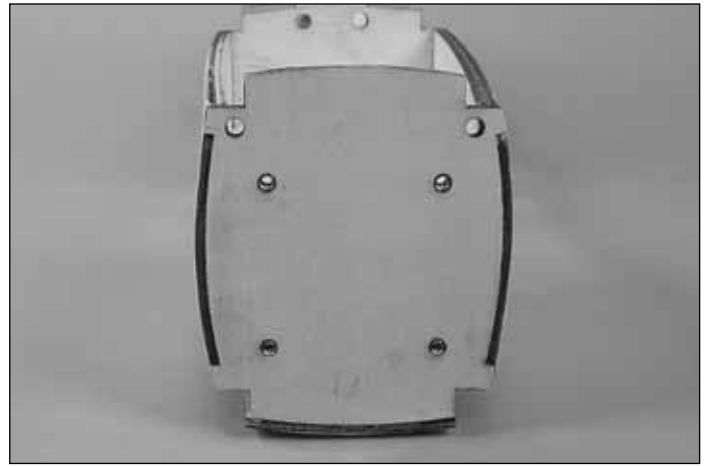

❑5. Test fit, then glue the firewall into position using 30-minute epoxy. Use rubber bands or clamps to hold the fuse sides tight to the firewall. The same way you did with former #8. Do not disturb the fuselage until the epoxy has fully cured.

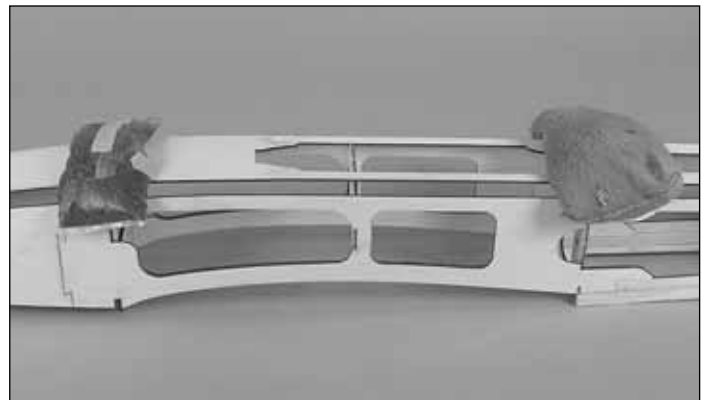

❑6. Flip the fuselage over and use weights to hold it down at F2 and F4.

❑7. Locate four of the 1/2" x 1/2" x 30" [13 x 13 x 762mm] balsa fuse corners. Start at F4 and glue a section from F4 to F1. Do both sides simultaneously. Then glue from F4 to F8. Again, do both simultaneously.

❑8. Glue the two die-cut 1/8" [3mm] ply **bolt blocks (BB)** together using medium CA.

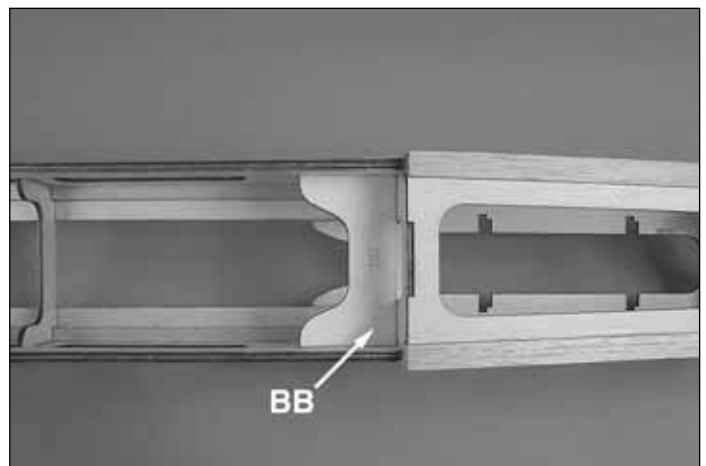

❑9. Test fit, then use epoxy to glue the bolt block in place.

Mount the Wing

Before finishing the bottom of the fuselage, we'll mount the wing.

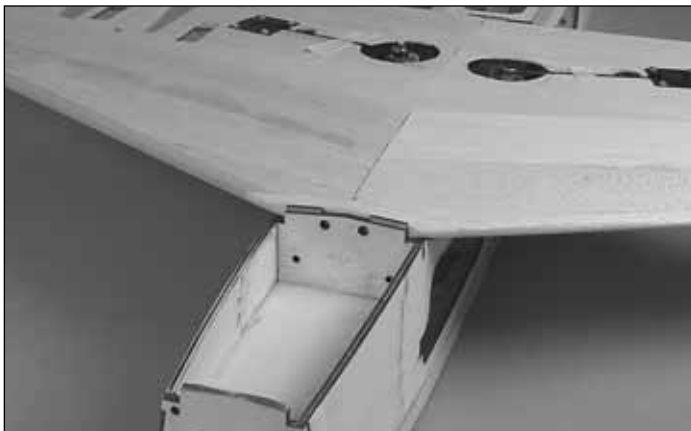

❑1. Fit the wing into the fuselage. Taking accurate measurements, center the wing from side-to-side. Holding the wing in position, use the holes in F2 as a guide to drill 1/4" [6.4mm] holes through the leading edge of the wing.

❑2. Remove the wing. Use the holes in the wing as a guide to drill the holes the rest of the way through the webbing inside the wing.



❑3. Round one end of both 1/4" x 3-1/2" [6.4 x 89mm] **wing dowels**. Use 30-minute epoxy to glue both dowels into the wing with 3/8" [10mm] protruding.

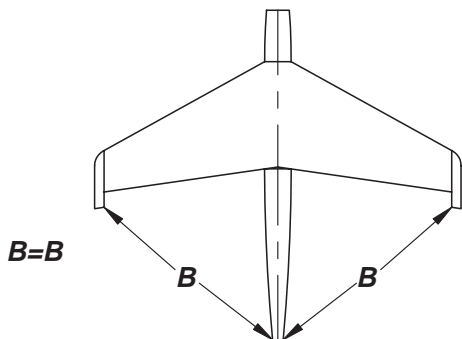

❑4. After the wing dowel epoxy has cured, fit the wing to the fuselage. Measure the distance from the end of the fuselage to both wing tips. Pivot the wing until the distances are equal as show by B=B in the sketch.



❑5. Glue the die-cut 1/8" [3mm] plywood **wing bolt plate** to the bottom of the wing as shown. Double check the measurements taken in the previous step to be certain the wing is centered.

❑6. Using the holes in the wing bolt plate as a guide, drill #7 holes through the wing and the bolt block in the fuselage. Remove the wing.



❑7. Use a 1/4-20 tap to cut threads into the holes in the bolt block. Add several drops of thin CA to the threads, allow to **fully** harden, and then retap the threads.

❑8. Enlarge the holes **in the wing only** with a 1/4" [6.4mm] drill. Test fit the wing to the fuselage with two 1/4-20 x 2" [50mm] nylon **wing bolts**. Make adjustments where necessary.

Finish the Bottom of the Fuselage

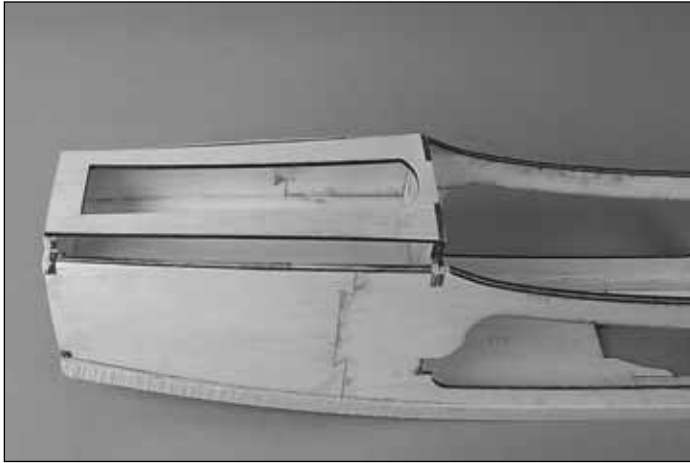

1. Glue the die-cut 1/8" [3mm] ply **forward fuse bottom (FFB)** in place using medium CA.



2. Glue the leftover 1/2" [13mm] corner pieces in place.

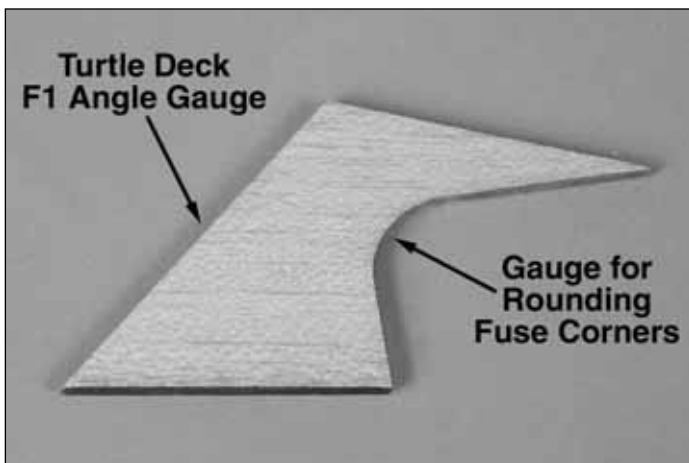

3. Sand the corners of the fuse to match the shape of the die-cut 1/8" plywood gauge.

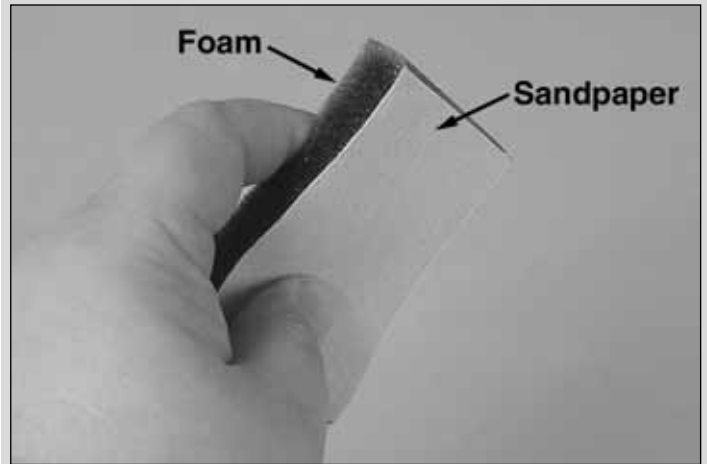

Start with a bar sander and 80-grit sandpaper to get the approximate shape of the corners, then use a finer grain sandpaper to better shape it. Adhesive-backed, 220-grit paper attached to a piece of foam makes an excellent fine sander.

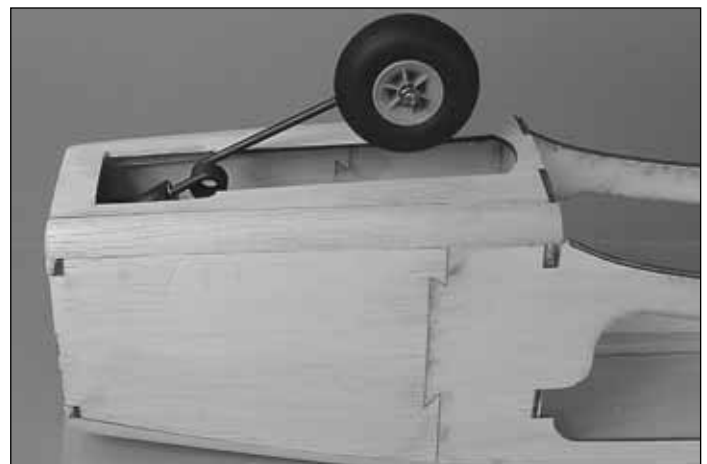
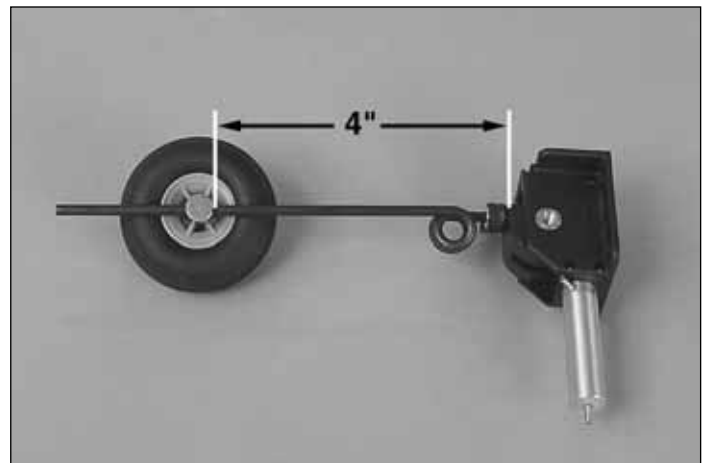

4. If you are installing retracts, now is a good time to fit the **retractable nose gear**. Install the retract into the nose of the fuse. You may have to trim FFB a little to allow the base of the retract to clear. Test fit the axle, wheel collar and 2" [57mm] nose wheel on the strut. Note where the wheel and the axle

need to be positioned to clear the wheel well. Mark the axle and strut and cut off 1/8" [3mm] after the mark. Make flat spots on the axle and strut where the set screws tighten.

❑5. Locate two plastic 3/16" x 36" [5 x 914mm] **pushrod tubes**. Sand the tubes with coarse sandpaper to allow the CA to adhere.

❑6. Guide the pushrods through the firewall and the tail as shown on the plan. The throttle pushrod tube will stop at F5, just before the throttle servo. The nosewheel steering pushrod tube will stop at F6. Cut off the excess tubes. If installing retracts, the nosewheel steering pushrod will begin between F1 and F2.

❑7. Glue each section that passes through a former with medium CA.

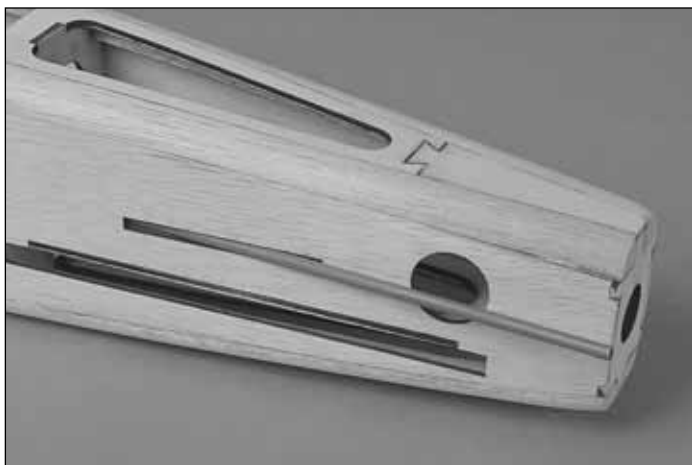

❑8. Insert the leftover tubes through the slots in the rear of the fuse and into the hole in F7. The tube should extend past F7 by approximately 1/8" [3mm]. Glue the tubes in place at F7.



❑9. Mix a batch of 30-minute epoxy with **microballoons** or talcum powder to create a thick, strong, easy-to-sand filler. Epoxy the tubes into the slots. Completely fill the slots with the mixture.

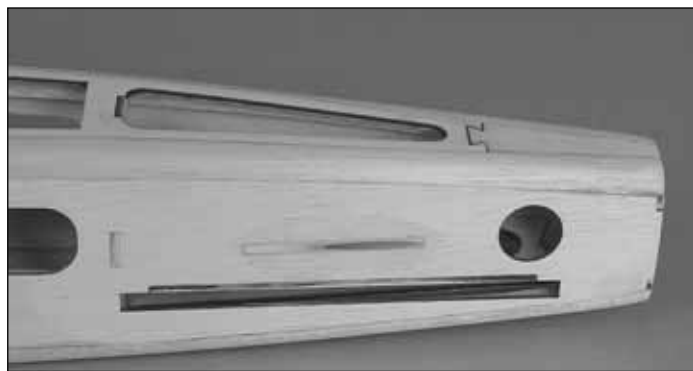

❑10. After the epoxy has cured, use a bar sander and 150-grit sandpaper to sand the outer pushrod tubes and epoxy filler flush with the fuselage sides.

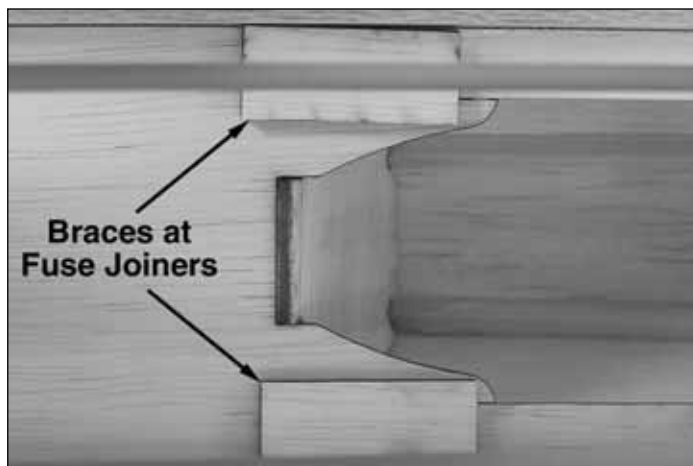

❑11. Locate the nine die-cut 1/8" [3mm] plywood **braces**. Glue these in place with medium CA wherever there is a joint on the fuse frame. Shown in the photo are the joints where the fuselage joiners join FFS and AFS. Brace similar joints throughout the model.

Build the Turtle Deck

❑1. Locate the four die-cut 1/8" [3mm] plywood **turtle deck formers (T1-T4)**.



❑2. Use the gauge you used to shape the corners of the fuselage to fit T1 as shown and glue in place using thin CA.

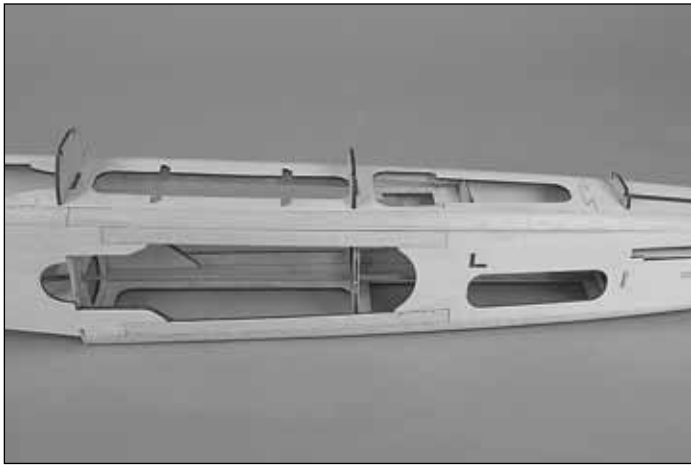

❑ 3. Glue T2 through T4 in place using thin CA. Check to make sure they are perpendicular to the fuse by using a square, or Hobbico Builders Triangle.

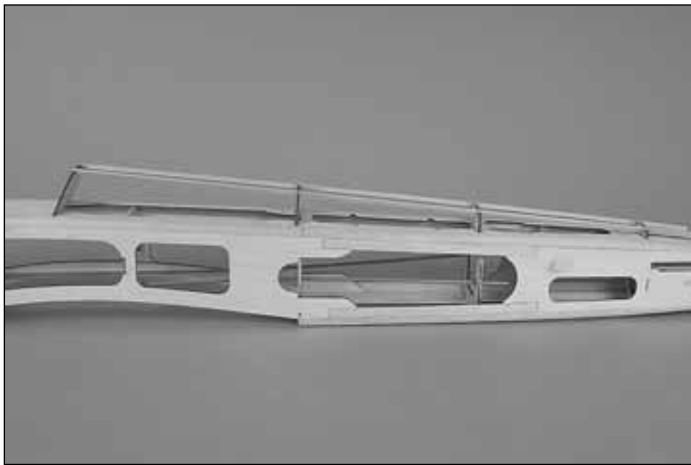

❑ 4. Locate the two 1/8" x 1/4" x 30" [3 x 6 x 760mm] balsa **turtle deck stringers**. You will notice there are slots in the formers for these stringers. Using medium CA, glue the stringers in place from T1-T4. Trim and sand the ends flush with formers T1 and T4.

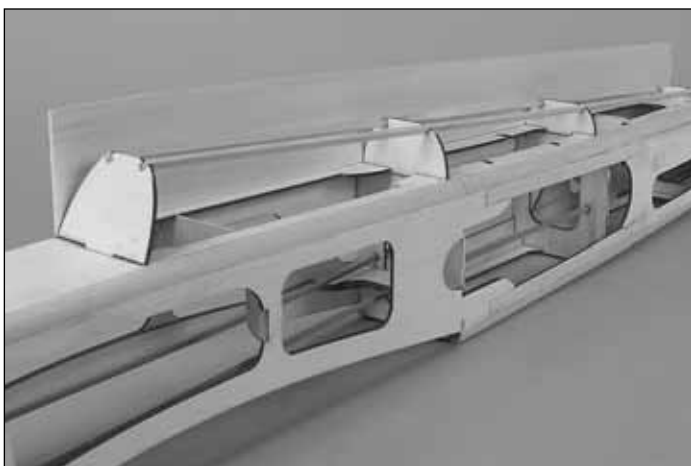

❑ 5. Position a 3/32" x 3" x 30" balsa sheet as shown. Trim the sheeting approximately 1/8" [3mm] past the TD stringers. Be careful not to trim too much. When the sheeting rolls over, it should clear the TD stringers.

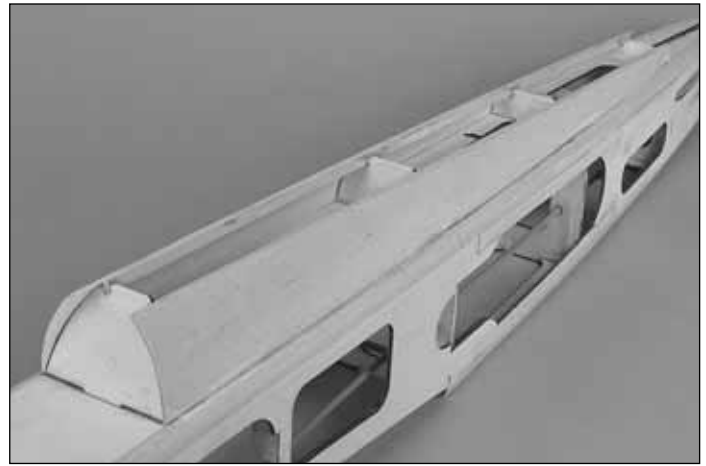

❑ 6. Run a bead of medium CA on the bottom edge of the sheeting and glue to the fuse top. When the glue has hardened, wet the balsa sheeting with warm water. Allow the water to soak in. This will allow you to bend the sheeting like you did on the wing. **CA activator** may help you here. Spray the sheeting with activator prior to running the bead of glue on the stringers and formers. So when you roll the sheeting over, the activator cures the CA instantly. Otherwise, apply CA the TD formers and the TD stringers with medium CA and roll the sheeting over. Hold in place until the CA hardens. Repeat for the other side of the TD.

❑ 7. Once you have both sides sheeted, trim the sheeting to match the TD formers. Use a sanding bar and 150-grit paper to make the sheeting flush along the top.



❑ 8. Locate the 1/4" x 2" x 30" balsa [6 x 50 x 760mm] **turtle deck top**. Test fit the TD top; it should rest flush on all sides and be level. Sand as needed for a good fit.

❑ 9. Apply a bead of CA along the top of the TD formers and stringers and firmly press the TD top down to glue in place.



❑ 10. Measure and mark a centerline down the TD top. This will act as your guide during the shaping.

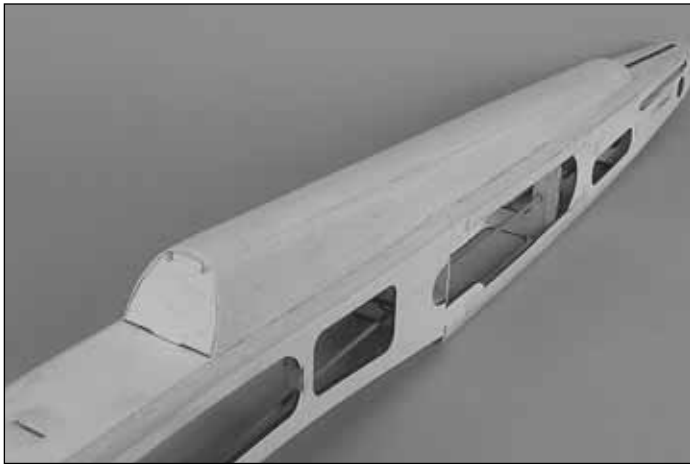

❑ 11. Sand the turtle deck to the shape shown on the cross-section. Sand the leading edge flush with T1 and the trailing edge flush with T4. **Note:** Fill any gaps with Hobblylite™ Balsa colored filler.

Install the Radio Hatch

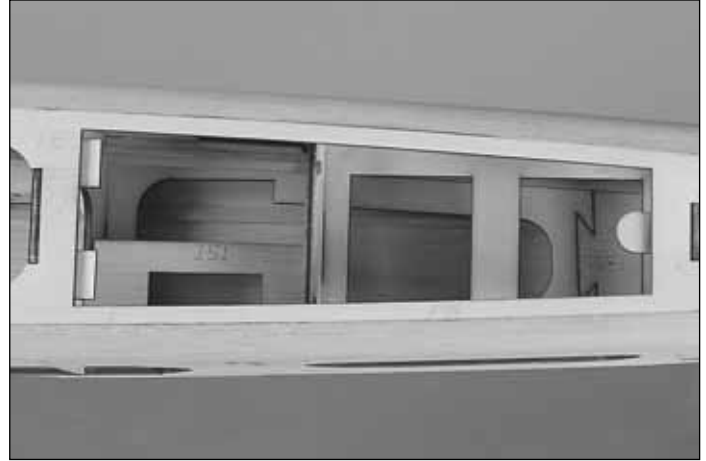

❑ 1. Locate the die-cut 1/8" [3mm] plywood **radio hatch (RH)** and die-cut 1/8" [3mm] plywood **radio hatch supports**. Glue the two hatch supports to the inside forward of the hatch area and the curved support to the aft section as shown on the plan.



❑ 2. Glue the die-cut 1/8" x 1" [3 x 25mm] plywood support to the radio hatch.

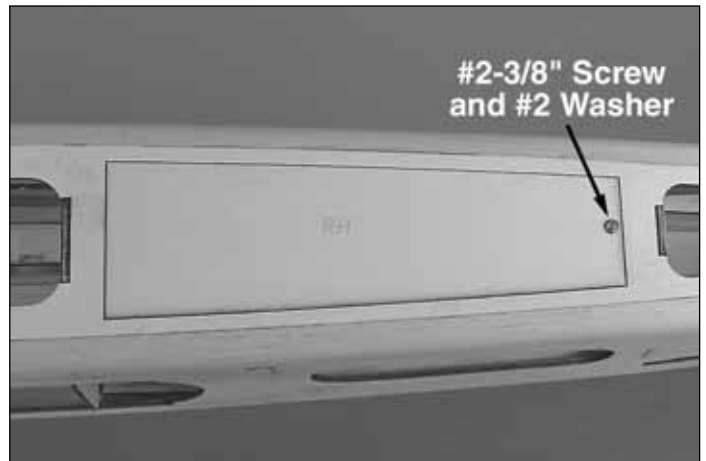

❑ 3. Drill a 1/16" pilot hole as shown on the plan. Remove the hatch and enlarge the hole to 3/32" [2.4mm]. Use a #2 x 3/8" [9.5mm] screw and #2 flat washer to secure the hatch.

Mount the Stabilizer to the Fuse

❑ 1. If you have not already done so, make sure the stab and fin are final-sanded smooth. Mount the wing to the fuselage.

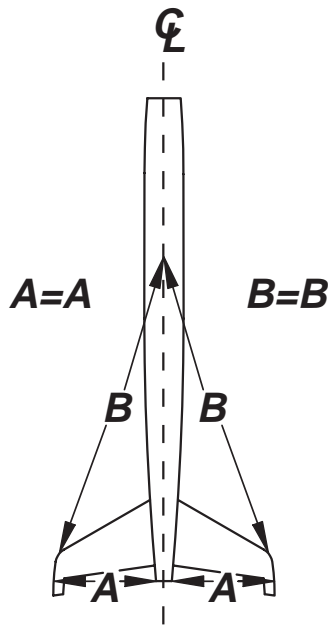

❑ 2. Insert the stab into the slot in the sides of the fuse. Measure the distance from a center point forward and the outside corner of the TE of the stab. Also measure the distance from the outside corner of the TE to the fuse side. These measurements should be equal as well.

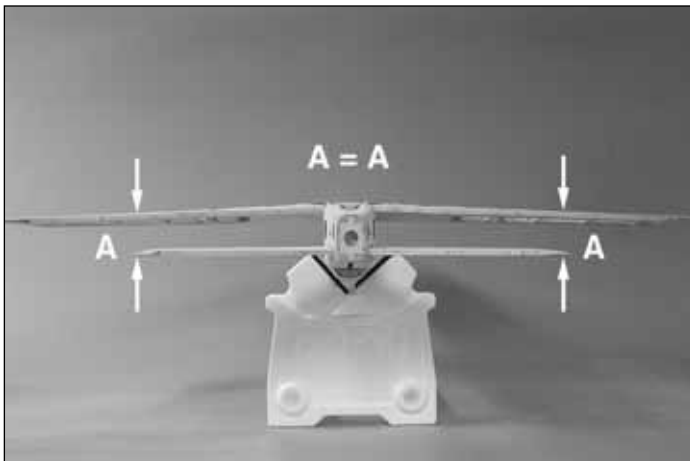

❑ 3. Stand about six to ten feet [2 to 3 meters] behind the model and see if the stab is parallel with the wing. It may be necessary to shim the stab to get proper alignment with the wing.

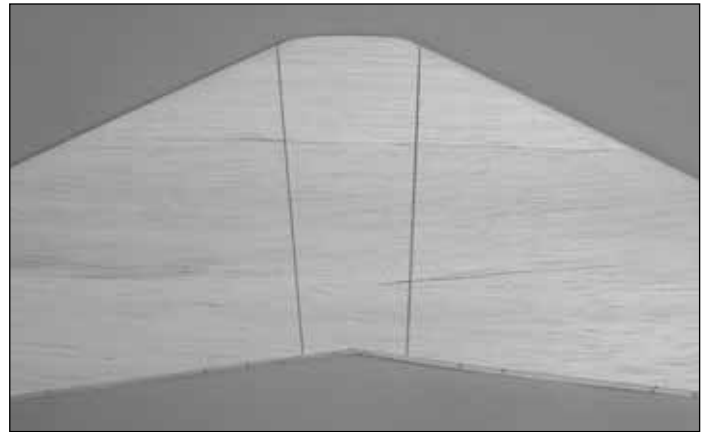
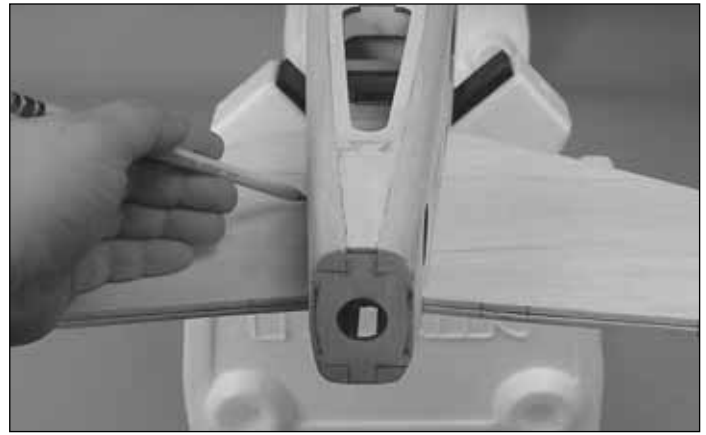

❑ 4. Once the stab is aligned, use a fine tip ballpoint pen to mark the stab where it enters the fuselage on the top and bottom.

❑ 5. Remove the stab and mix up a generous amount of 30 minute epoxy. Brush epoxy inside the area you just marked and slide the stab back into place. Use the lines you drew as a reference. Clean up excess epoxy with a towel and denatured alcohol. Verify alignment and allow the epoxy to fully cure before proceeding.

Mount the Fin to the Fuse

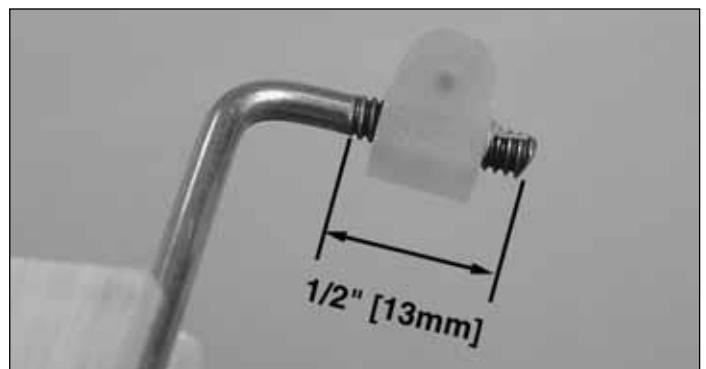

❑ 1. Cut the threaded end of the **rudder torque rod** to the length shown on the plan.

❑ 2. Screw the 4-40 **nylon torque rod horn** on the threaded end of the torque rod to the location shown.

❑3. Mark the TE of the fin where the nylon bearing on the torque rod will be inserted. Mark the rudder where the arm of the torque rod will be inserted. See plan for locations.



❑4. Drill a 7/64" [3mm] hole 5/8" [16mm] deep in the leading edge of the rudder at the mark you made for the rudder torque rod. Cut a groove in the rudder for the rod. The Great Planes Groove Tube™ works great for this task. Test fit the rudder torque rod in the rudder. Cut a slot in the trailing edge of the fin at the marks you made for the nylon torque rod bearing. Without using any glue, test fit the rudder to the fin with the rudder torque rod in place. When satisfied with the fit, remove the rudder and set it aside.

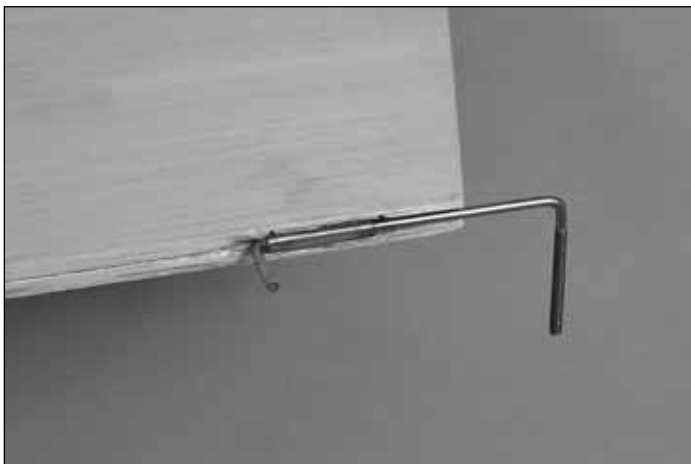

❑5. Glue the bearing in place with epoxy, being careful not to get any glue on the rod or in the bearing. **DO NOT GLUE THE RUDDER IN PLACE AT THIS TIME.**

❑6. Slide the fin fully into the fin slot. Use a fine tip ballpoint pen to mark the fin where it enters the slot on both sides. Remove the fin. Mix a generous amount of 30 minute epoxy. Apply epoxy to the top of the stab through the fin slot and to the sides of the fin below the lines. Insert the fin, being careful not to get epoxy on the nylon torque rod bearing.

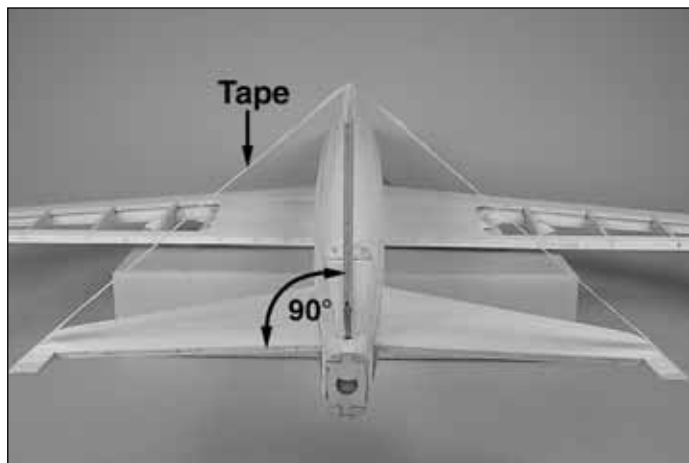
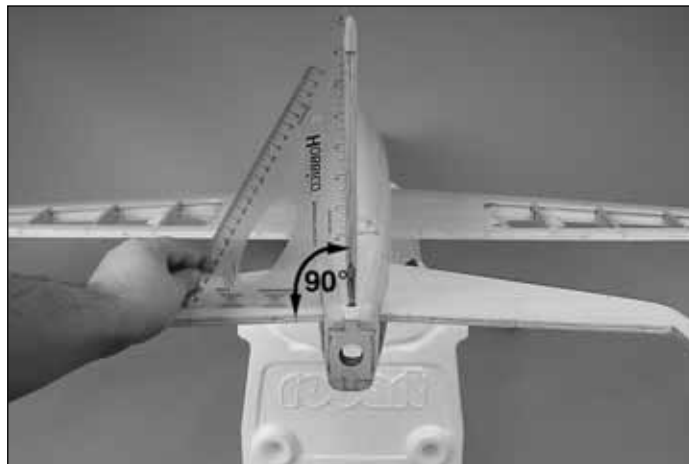

❑7. Use a builders triangle to make sure the fin is vertical and hold it in place with masking tape while the epoxy cures. Wipe away excess epoxy with denatured alcohol and a paper towel.

Install the Fuel Tank

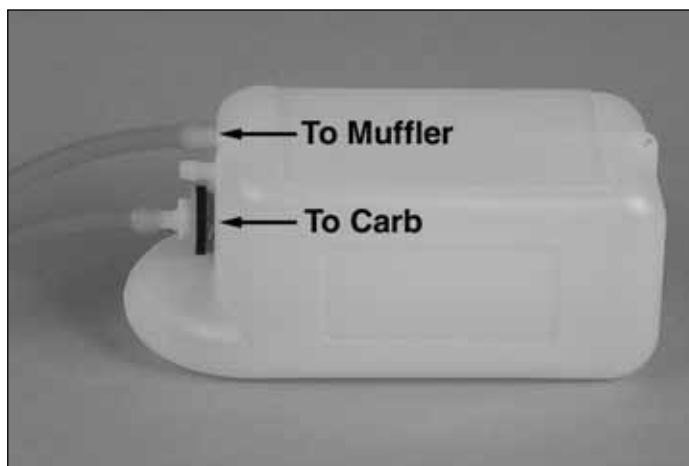

❑1. Assemble and install the tank cap. Attach a 12" [300mm] piece of fuel tubing to the upper nipple, which will attach to the muffler pressure tap. Attach a second piece of 12" [300mm] fuel tubing to the main nipple in the center of the tank cap, which will attach to the carburetor.

- ❑2. Remove the tank and fuelproof the fuel tank compartment with thinned out epoxy or fuelproof doping.

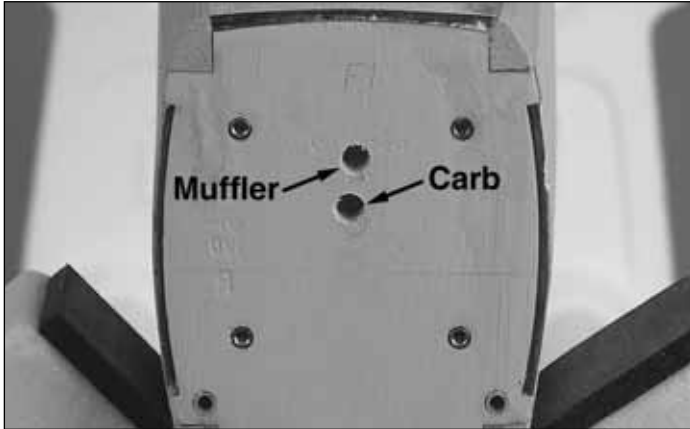

- ❑3. Drill two 1/4" [6mm] holes in the firewall **above** the tank floor as shown. Route the two 12" [300mm] lengths of fuel tubing from the tank through these holes and into the tank compartment. Pull the fuel tank into place with the fuel tubing. **Note:** Some modelers may wish to wrap the tank in foam prior to installing it. This is fine, but it will be a tight fit. Simply bracing it with small balsa blocks after sliding it in will be perfectly acceptable.

Mount the Engine

- ❑1. Cut the "spreader bars" from the included Great Planes engine mount, and then use a hobby knife to remove any flashing leftover from the molding process so that the halves fit together well.
- ❑2. Temporarily attach the engine mount to the firewall with four 6-32 x 1" socket head bolts and #6 flat washers but do not tighten the screws all the way.
- ❑3. Place the engine on the mount and slide the halves in or out until the engine fits. When the engine mount is adjusted and positioned, tighten the mounting screws.

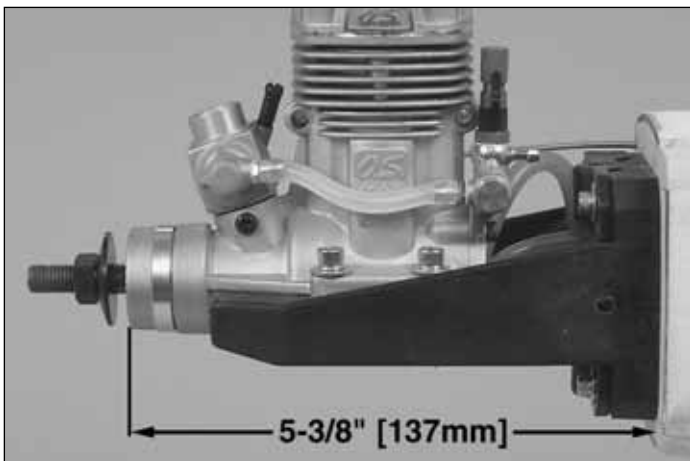

- ❑4. Position the engine on the mount so the drive washer (or the back of the spinner) is 5-3/8" [137mm] from the firewall.

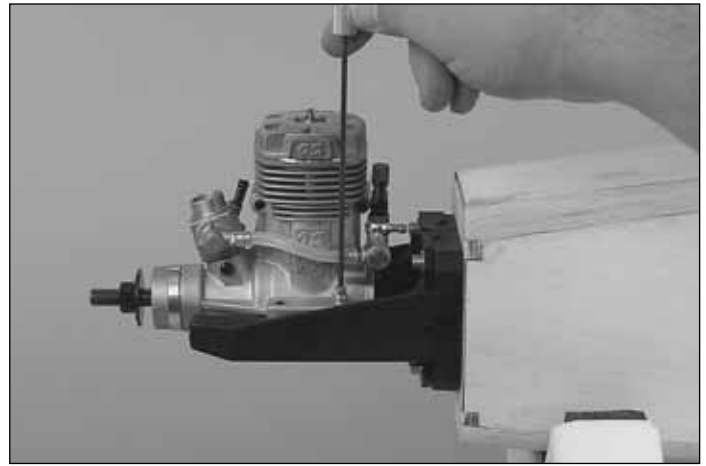

- ❑5. Use the Great Planes Dead Center™ Engine Mount Hole Locator or another method to mark the locations of the bolt holes. Remove the engine from the mount and drill four #36 or 7/64" [2.8mm] holes. Tap the holes with a 6-32 tap.
- ❑6. Bolt the engine to the mount with four 6-32 x 3/4" [19mm] socket head screws, #6 washers, and lock washers.
- ❑7. If installing retracts, proceed to **"Install the Servos and Pushrods."**

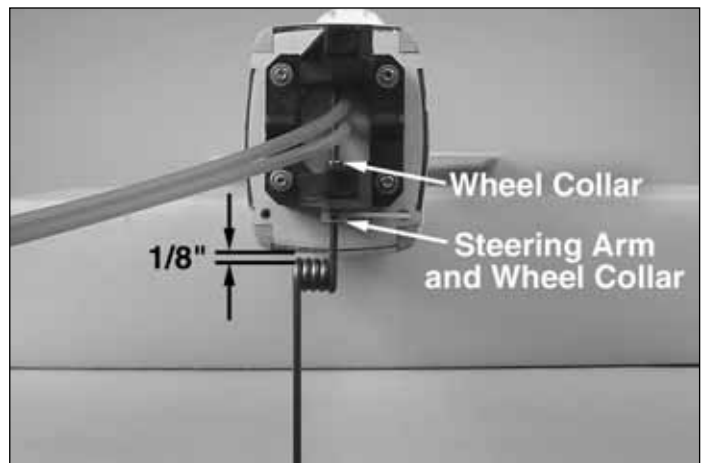

- ❑8. Mount the nose gear to the engine mount as shown using a nylon steering arm with a 5/32" wheel collar and a 6-32 x 1/2" [13mm] socket head cap screw, another 5-32" wheel collar and a 6-32 set screw. Position the wheel collars so the gear will be positioned as shown (with the coil in the wire approximately 1/8" [3mm] from the bottom of the fuselage.) Be sure to grind flat spots on the nose gear wire where the steering arm set screw and wheel collar set screw will tighten.

Install the Servos and Pushrods

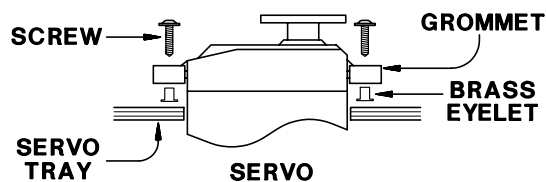

- ❑ 1. Mount the throttle servo as shown on the plan using the hardware that came with your servo. Once the servo is mounted, remove the screws and servo. Add a few drops of CA to each hole to harden the threads. Allow the CA to **fully** harden, and then reinstall the servo.

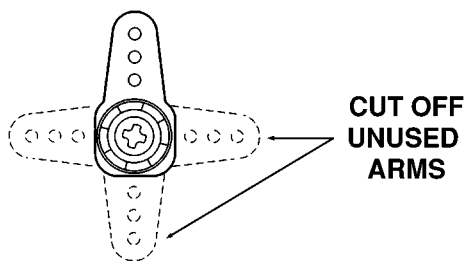
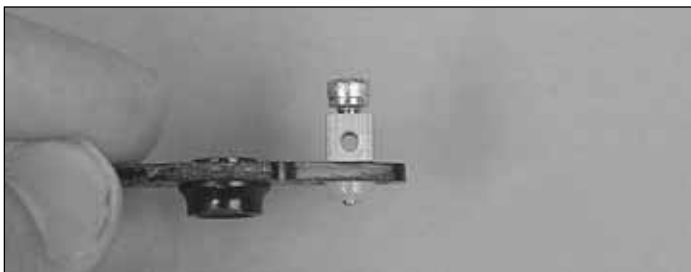

- ❑ 2. Install a **screw-lock connector** on the throttle servo arm on the furthest-out hole.

- ❑ 3. Install a nylon clevis and retainer to the 42" [1070mm] throttle pushrod wire. Slide the pushrod through the pushrod tube with the clevis on the **carb** end.

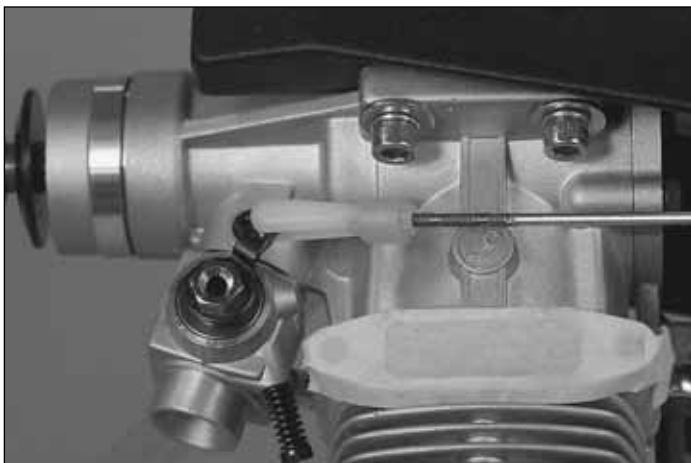

- ❑ 4. Bend the carb end of the throttle pushrod as needed to fit the engine installation. Make adjustments to the bends in

the wire so the pushrod aligns with the **carburetor arm** on the engine, and then temporarily connect the pushrod to the carb arm. Temporarily mount the muffler and make sure the throttle pushrod will not interfere with the muffler. Make adjustments to the bends in the wire if necessary.

- ❑ 5. Slide the pushrod wire through the screw-lock connector on the throttle servo and temporarily tighten the screw.

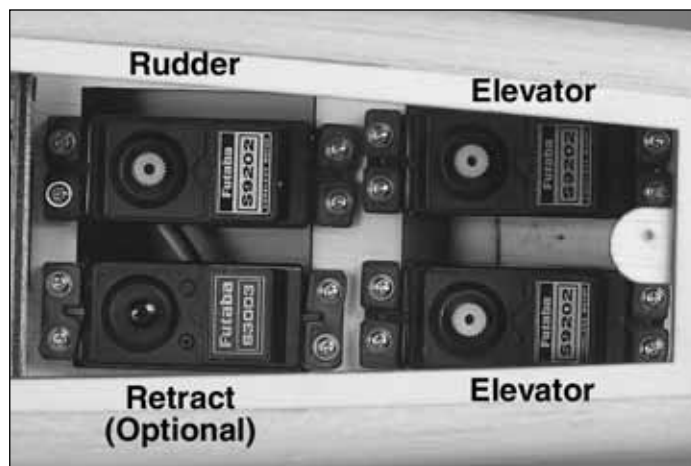

- ❑ 6. Insert the two elevator servos, the rudder servo, and the retract servo (if used) as shown. Align the servos with the pushrods and mount the servos using the screws provided by the servo manufacturer. Once the servo is mounted, remove the servo and harden the threads with thin CA.

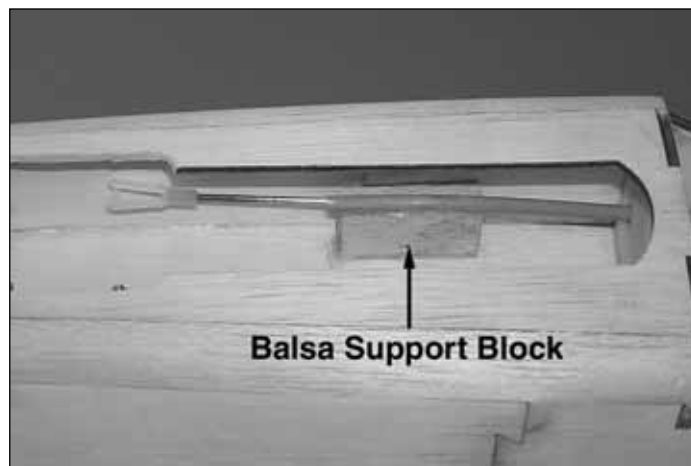

- ❑ 7. If installing fixed gear, route the remaining 42" [1070mm] pushrod through the firewall and guide tube until it reaches the servo. Install a screw lock connector on the rudder servo arm for the nose wheel. **If you installed retracts, see the photo above for reference.** With a nose gear retract, the pushrod and pushrod tube will not exit the firewall. You will need to cut the pushrod and tube to the approximate length shown. Using a leftover balsa stick, make a support for the pushrod tube inside the tank area. Attach the clevis to the steering arm on the retract.

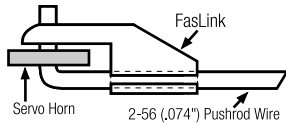

❑8. Thread a nylon swivel clevis and retainer onto the 12" [300mm] pushrod (threaded on one end). Connect the clevis to the rudder torque rod and mark the point where the pushrod crosses the rudder servo arm. Make a 90° bend at that point in the pushrod. Insert the pushrod into the servo arm. Snap in place using the nylon **Faslink** as shown. Trim off all but about 1/16" [1.6mm] past the Faslink.

❑15. Connect the clevis to the control horn. Center the ailerona and position the servo arms perpendicular to the servo case. **Hint:** A small clamp can help hold the ailerons even with the wing tip as shown.

❑9. Thread a nylon clevis and retainer onto the 12" [300mm] pushrod (threaded on one end) for the elevator pushrod. Slide the pushrod wires through the two elevator pushrod guide tubes, which are on the left and right sides of the fuselage. Remove the **backing plate** from a nylon control horn and connect the horn to the clevis in the outer hole. Fit the elevator to the stab, using the hinges to hold them in place. **DO NOT GLUE THE HINGES IN PLACE.**

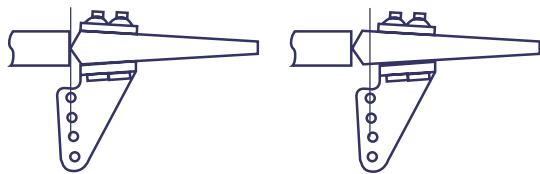

Correct

Incorrect

❑16. Align the pushrod with the outer hole on the aileron servo arm. Mark the pushrod where it crosses the servo arm. Bend the pushrod down 90° at the mark. Enlarge the hole in the servo arm slightly with a 5/64" [2mm] drill bit and insert the pushrod.

❑10. Position the control horns on the elevators as shown in the sketch and on the plan. Use a ballpoint pen to mark the location of the control horn mounting holes and drill 3/32" [2.4mm] holes at the marks. Temporarily mount the control horn to the elevators with the backing plate and 2-56 x 5/8" [16mm] screws.

❑17. Install the Faslink first, then trim to 1/16" past the bottom of the Faslink. Do this for both aileron servos.

❑11. Attach the elevator pushrods to the servos with Faslinks using the same procedure as you did with the rudder.



❑12. Install the wing servos using the screws and hardware provided by your manufacturer.

❑13. Thread a nylon clevis and retainer onto each of the four 6" [150mm] **pushrods**.

❑18. The flap linkages are done the same as the ailerons with one difference. The servo arm on the flaps will be angled toward the flap as shown. This will give you the angle needed to deflect the flaps to their full extent.

❑14. Position the control horns on the ailerons and flaps as shown on the plan. Use a ballpoint pen to mark the location of the control horn mounting holes and drill 3/32" [2.4mm] holes at the marks. Temporarily mount the control horn to the ailerons with the backing plate and 2-56 x 5/8" [16mm] screws.

Assemble the Instrument Panel (Optional)

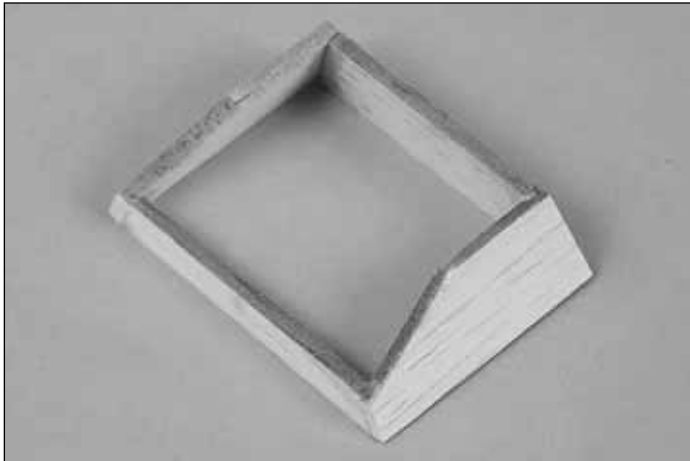

- Assemble the instrument panel as shown.

Assemble the Cowl

- 1. Locate the two halves of the **cowl** and carefully cut out the two halves. Cut as close to the bottom of the molding as possible.

- 2. Test fit the cowl halves. Trim as necessary to get the two halves to meet flush.



- 3. Using masking tape, hold the two halves of the cowl together as they would be when attached to the fuse.

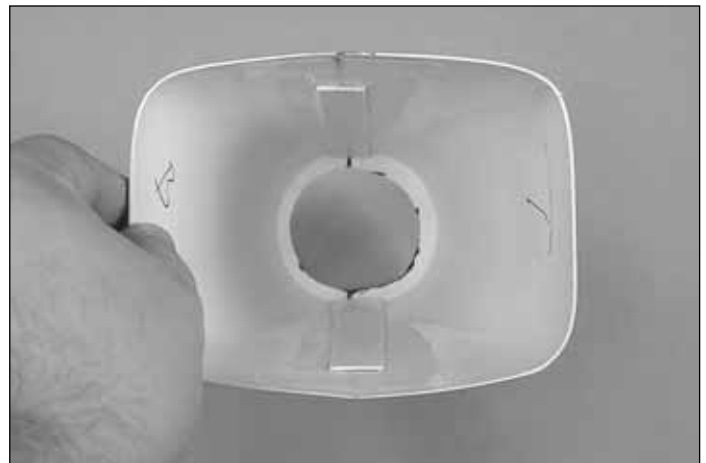

- 4. Cut two strips of leftover ABS plastic to make braces for the inside of the cowl where they are joined. Be sure to leave enough room for the cowl to slide over the fuse, so the sheeting does not get in the way. Glue in place using medium CA.



❑5. Now that the cowl halves are joined, sand each joint lightly so any filler used will adhere. We recommend filler such as Bondo or Squadron White Putty. We used **Squadron Green Putty** for clarity in photos. When the filler has dried **completely**, wet sand with 400-grit sandpaper to get the cowl ready for priming.

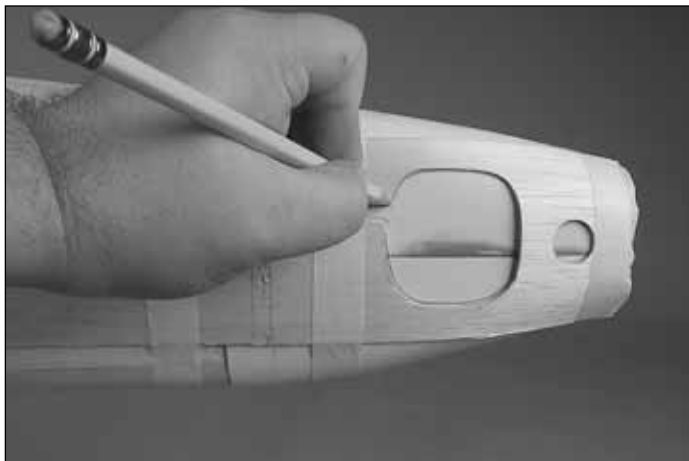

❑6. Make a cutout in the cowl to allow the engine to clear the cowl. An easy way of doing this is: While the engine is mounted, take a large piece of leftover balsa (or heavyweight paper), and tape it to the side of the fuselage. Mark the location where the engine contacts the balsa and cutout the shape. Then remove the engine, leaving the balsa taped to the fuse. Slide the cowl into place and trace the outline of the engine onto the cowl. Cut away the area marked by your template.

❑7. Remount the engine and test fit the cowl. Make any adjustments necessary to clear the engine.

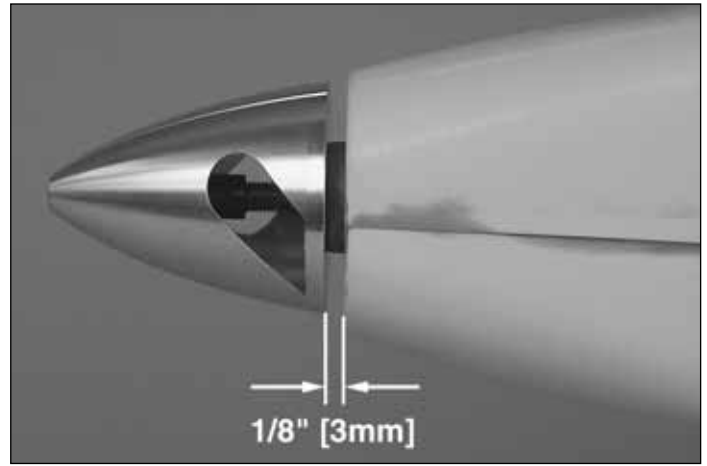

❑8. Attach the spinner backplate to the engine crankshaft. The spinner backplate should be approximately 1/8" [3mm] in front of the cowl. Once the cowl is in place, attach it to the fuselage using #2 x 3/8" screws and #2 washers.

❑9. Prime and paint the cowl to match the model.

Install the ABS Plastic Details

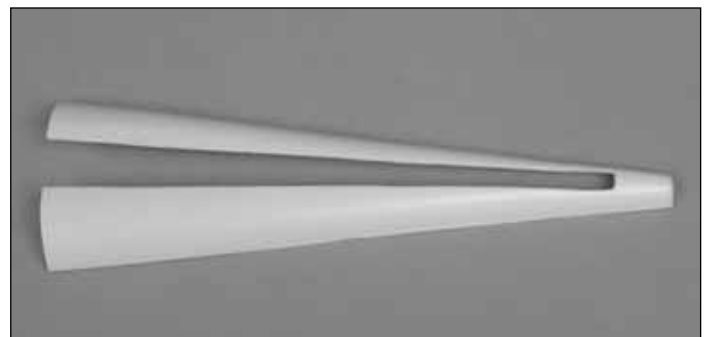

❑1. Cut the **ABS tail fairing** just outside of the cut lines. The lines are there as a "guide" for a proper fit. You may need to trim more or less depending on how you shaped the turtle deck. Test fit and trim as needed. It should look close to the photo above.

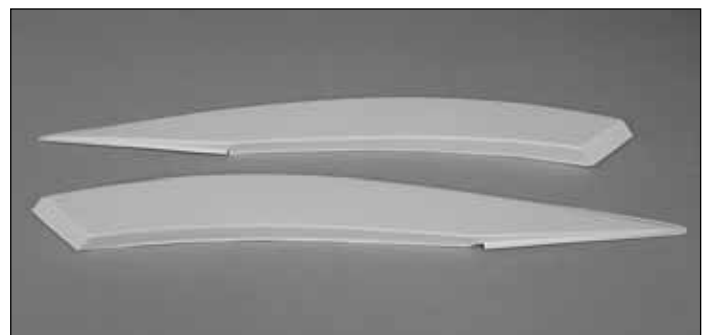

❑2. Cut the side **air intakes** along the cut lines. Test fit and trim as needed to resemble photo.

❑3. Cut the tail cone approximately 1/4" [6mm] longer than the cut line. This gives you some play in getting the cone to fit. Test fit and trim as needed for a good fit.

INSTALL THE HARDWARE

- ❑ 1. Reinstall the fuel tank, running the carb and vent lines out of the holes in the firewall. Mark on the firewall with permanent marker which line is vent and which line is carb (fuel).
- ❑ 2. Connect the fuel lines to the carb and exhaust.
- ❑ 3. Mount the landing gear to the fuselage.
- ❑ 4. If you used pneumatic retracts, run all air tubing and install the gear.

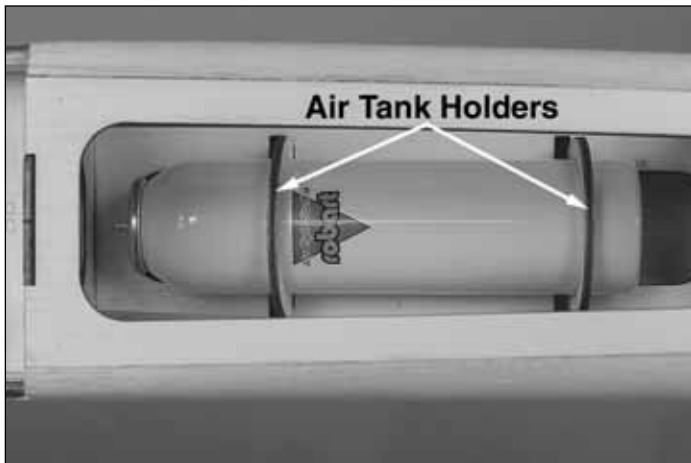

- ❑ 5. Install the air cylinder for your retracts as shown using the 1/8" [3mm] air tank holders. Push the ends of the air tank holders in the slots and slide forward into place.

BALANCE THE MODEL Laterally

Do not confuse this procedure with "checking the C.G.", which will be discussed later in the manual. A model which is not laterally balanced may exhibit a variety of unpleasant traits, ranging from uncharacteristic tip stalls to problems with spin entries. This aircraft, when balanced properly, exhibits none of these tendencies. Be sure to check the lateral balance carefully as described to help ensure that the model exhibits the same exceptional handling qualities as our prototypes.

- ❑ 1. With the wing level, have an assistant help you lift the model by the engine propeller shaft and the bottom of the fuse under the TE of the fin. Do this several times.
- ❑ 2. If one wing always drops when you lift the model, it means that side is heavy. Balance the airplane by adding weight to the other wing tip. An airplane that has been laterally balanced will track better in loops and other maneuvers.

PREPARE THE MODEL FOR COVERING

- ❑ 1. Remove all the pushrods and control horns from the ailerons, elevators, and rudder. Remove the engine, engine mount and any other hardware you may have installed
- ❑ 2. Most of the model should be rough-sanded by now, with all the tabs and rough edges sanded even. Fill all dents, seams, low spots, and notches with HobbyLite™ Balsa Colored Filler.
- ❑ 3. After the filler has dried, use progressively finer grades of sandpaper to even all the edges and seams and smooth all surfaces. Remove all balsa dust from the model with compressed air, a vacuum with a brush, or a tack cloth.
- ❑ 4. If you used retracts, install the air hoses and mount the air cylinder as shown.

FINAL SERVO AND RECEIVER INSTALLATION

- ❑ 1. Install all servos using the hardware supplied by your radio manufacturer.

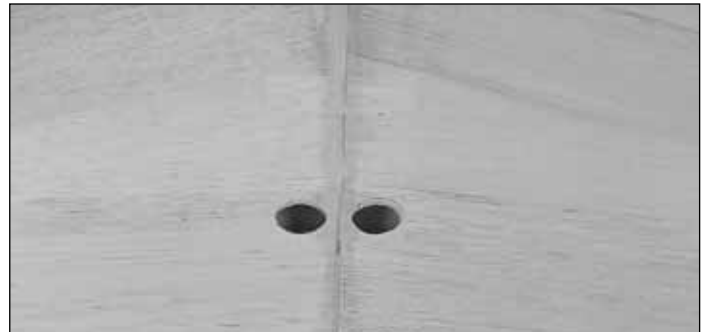

- ❑ 2. Cut two 3/4" [19mm] holes in the wing to route the servo leads. If you look inside the wheel well, you can see the hole in R5 that the servo leads will exit, make the holes in the wing just above the exit in R5.

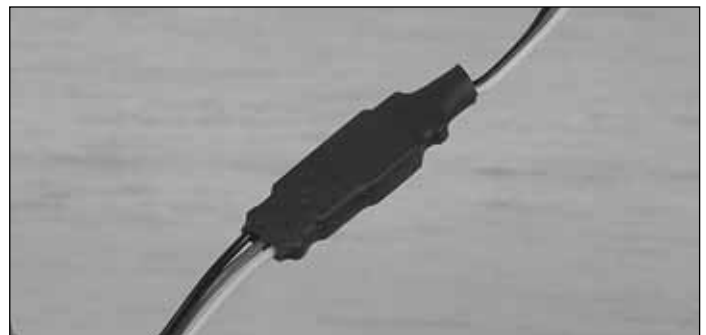

- ❑ 3. You will need to attach a 6" [150mm] **servo extension** to the aileron servos **PRIOR** to routing the servo lead. After you have the 6" [150mm] extension attached, cover the connection with heat shrink tubing (GPMM1070) and seal together as shown.

❑4. Route the servo leads through the holes provided in the wing ribs and out through the holes you made. **TIP:** We used a wheel collar tied to the end of a piece of string to route the servo leads out of the wing. Drop the wheel collar in through the holes you just made and out to the servos. Tie the leads to the wheel collar and pull back through.

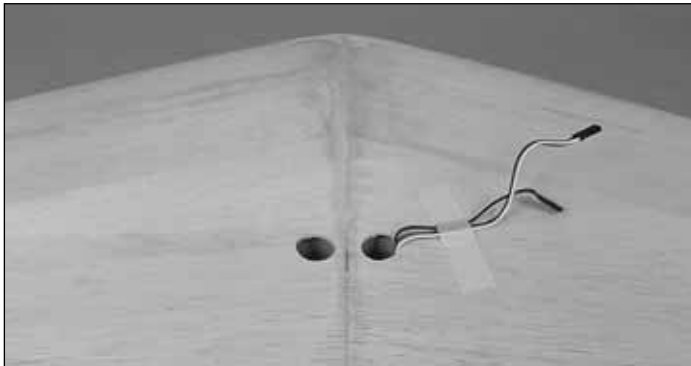

❑5. Tape the servo leads to the wing and repeat for the other side.

❑6. Reattach all control horns on the model.

❑7. Reinstall the aileron servos and pushrods. Temporarily plug the aileron servos into the receiver and plug the battery into the receiver. Turn on the transmitter and center the aileron trims.

❑8. Reposition the servo arms and clevises as needed to make the servo arm perpendicular to the servo case and the surface centered. Check that both servos move the correct direction, remembering that the wing is upside-down. (Reverse the servo direction in the radio if required.) Turn off the transmitter and unplug the battery and receiver. Set the wing aside for now.

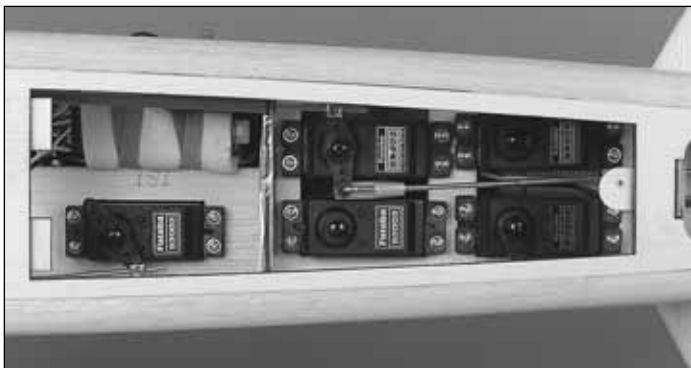

❑9. Wrap the receiver in 1/4" [6mm] foam and secure with rubber bands. The thickness of the foam will hold the receiver in place once it is in place. **TIP:** We set the receiver in place and then marked the location for the power switch. When the power switch is installed, the receiver is held in place by the switch body.

❑10. With the model upside-down in a stand and using the plans as a reference, locate the pushrod tube exit on the model's left and right side under the stab. Slice the covering along these openings to allow the pushrods to leave the fuselage.

❑11. Plug the servos and battery into the receiver. Turn on the transmitter and center the all of the trims. Center the control surfaces and connect the clevises to the control horns.

❑12. Route the antenna forward through the center of the plane.

COVER THE MODEL WITH MONOKOTE® FILM

Cover the model with **Top Flite MonoKote Film** using the recommended covering sequence that follows. Before you cover the fuselage, first apply 1/4" [6mm] wide strips of MonoKote film in the corners of the stab and fuse and the fin and the fuse, then proceed to cover the fin and stab with pre-cut pieces that meet in the corners and overlap the 1/4" [6mm] strips. **Never cut the covering on the stab and fin after it has been applied except around the leading and trailing edges and at the tips.** Modelers who cut covering on top of the wood structure may cut through the covering and into the stab or fin. This will weaken the structure to a point where it may fail during flight.

The colors given below are suggested to match the scheme on the box:

Aluminum (TOPQ0205, 2 rolls)
Royal Blue (TOPQ0221, 1 roll)
White (TOPQ0204, 1 roll)
Missile Red (TOPQ0201, 1 roll)

PAINT THE MODEL

After the model is covered, you must fuelproof the firewall. You may do so with fuelproof model paint, 30-minute epoxy thinned with alcohol, or finishing resin.

Top Flite LustreKote fuelproof paint is recommended for painting all the ABS plastic parts. At least one coat of LustreKote primer is highly recommended to fill any small scratches left from sanding as well as small pin holes in the filler. Wet sand between coats with 400-grit sandpaper and apply a second coat of primer if necessary. If the parts are primed properly, a few light coats of color will quickly provide you a beautiful match to the MonoKote.

The colors given below are suggested to match the scheme on the box:

Jet White (TOPR7505)
Aluminum (TOPR7506)
Royal Blue (TOPR7519)
Missile Red (TOPR7502)

Apply the Decals

1. Use scissors or a sharp hobby knife to cut the decals from the sheet.
2. Be certain the model is clean and free from oily fingerprints and dust. Prepare a dishpan or small bucket with a mixture of liquid dish soap and warm water—about one teaspoon of soap per gallon of water. Submerge the decal in the soap and water and peel off the paper backing. **Note:** Even though the decals have a “sticky-back” and are not the water transfer type, submersing them in soap & water allows accurate positioning and reduces air bubbles underneath.
3. Position the decal on the model where desired. Holding the decal down, use a paper towel to wipe most of the water away.
4. Use a piece of soft balsa or something similar to squeegee remaining water from under the decal. Apply the rest of the decals the same way.

Install the Canopy

1. Install the pilot's instrument panel (optional) as shown on the plan. If desired, install the pilot (optional, not included) and instrument gauge decal at this time.
2. Trim the canopy on the cut lines and place the canopy on the fuselage in the location shown on the plan. Temporarily hold it in position with tape or rubber bands.
3. Use a felt-tip pen to **accurately** trace the canopy outline onto the MonoKote film covering. Remove the canopy.
4. Use a sharp #11 blade to **carefully** cut the covering about 1/32" [1mm] inside of the line you marked **without cutting into the balsa**. Cut the covering 1/16" [1.6mm] inside of the seam you just made, again without cutting into the balsa. Carefully remove the 1/16" [1.6mm] wide strip of covering. Wipe away the ink line with a paper towel lightly dampened with alcohol.
5. Before you permanently glue the canopy to the fuselage, securely glue the pilot in place.
6. Reposition the canopy on the fuselage and confirm that it covers the exposed wood. Glue the canopy to the fuselage, using rubber bands or masking tape to hold it in position until the glue dries. We recommend an adhesive specifically formulated for gluing on canopies such as Pacer “Formula 560” canopy glue. Formula 560 is like regular white glue (aliphatic resin) in that it dries clear and cleans up with water, but it sticks extremely well to butyrate and dries overnight (to allow for accurate positioning).

Attach the Control Surfaces

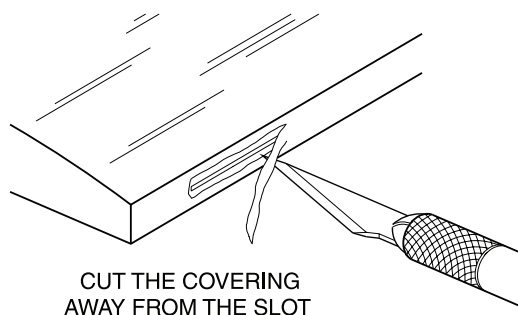

1. Start with the elevators and stab. Cut the covering from the hinge slots—don't just slit the covering but remove a small strip the size of the hinge slot.

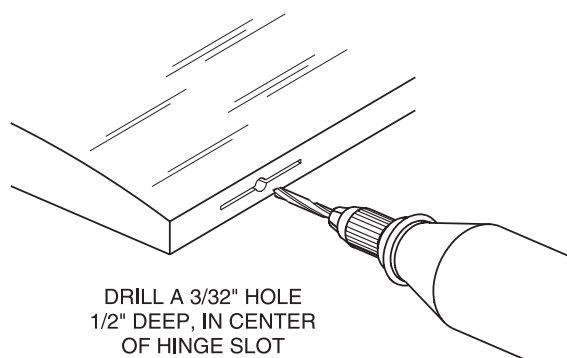

2. Drill a 3/32" [2.4mm] hole 1/2" [13mm] deep in the center of each hinge slot. A high speed Dremel® Tool works best for this. If you use a regular drill, clean out the hinge slots with a #11 blade. If you used a Slot Machine to cut the hinge slots, this step is not needed.

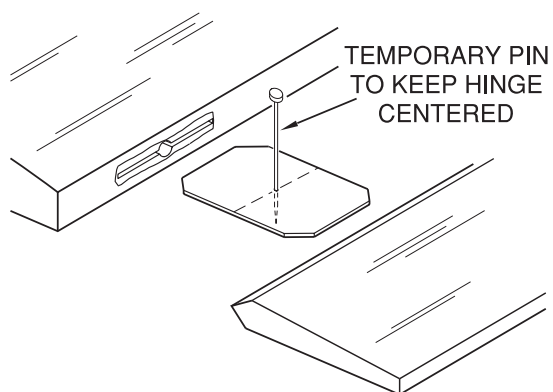

3. Without using any glue, fit the hinges in the elevators or stab. Insert a small pin in the center of the hinges to keep them centered. Do not glue the hinges yet. Do not use accelerator on any of the hinges. Do not glue the hinges with anything but thin CA and do not attempt to glue one half of the hinge at a time with medium or thick CA. They will not be properly secured and the controls could separate while the model is in flight.

ASSEMBLE, THEN APPLY 6 DROPS OF THIN CA TO CENTER OF HINGE, ON BOTH SIDES

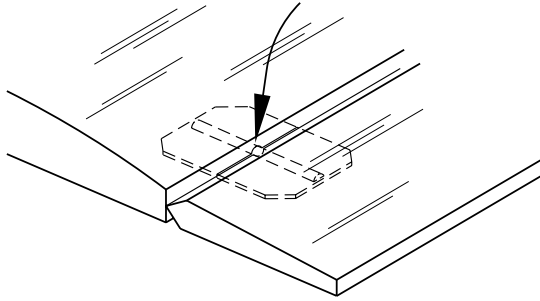

❑4. Prepare the hinge slots for the rudder as you did the elevators. Join the rudder to the fin with the hinges and use 30-minute epoxy to simultaneously glue the rudder torque rod in the rudder. Glue the hinges in position with thin CA.

❑5. Prepare the hinge slots in the ailerons the same way you did for the tail surfaces. Glue the hinges with thin CA.

GET THE MODEL READY TO FLY

Check the Control Directions

❑1. Turn on the transmitter and receiver and center the trims. If necessary, remove the servo arms from the servos and reposition them so they are centered. Reinstall the screws that hold on the servo arms.

❑2. With the transmitter and receiver still on, check all the control surfaces to see if they are centered. If necessary, adjust the clevises on the pushrods to center the control surfaces.

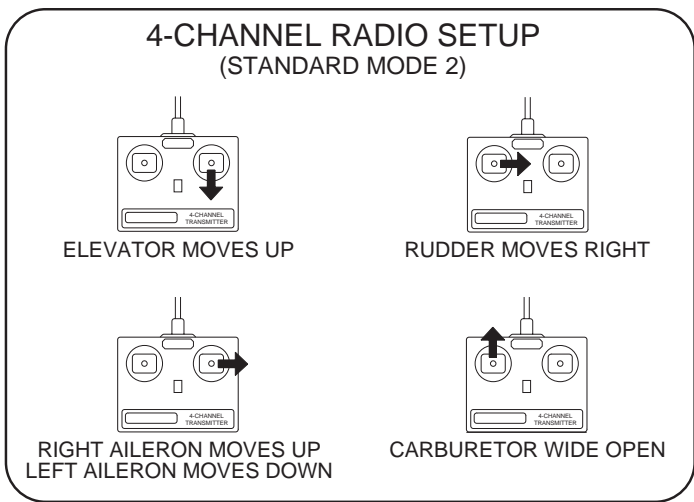

❑3. Make certain that the control surfaces and the carburetor respond in the correct direction as shown in the diagram. If any of the controls respond in the wrong direction, use the servo reversing in the transmitter to reverse the servos connected to those controls. Be certain the control surfaces have remained centered. Adjust if necessary.

Set the Control Throws



Use a Great Planes AccuThrow (or a ruler) to accurately measure and set the control throw of each control surface as indicated in the chart that follows. If your radio does not have dual rates, we recommend setting the throws at the low rate setting.

NOTE: The throws are measured at the **widest** part of the elevators, rudder and ailerons.

These are the recommend control surface throws:

	High Rate	Low Rate
ELEVATOR:	3/8" [10mm] up 3/8" [10mm] down	1/4" [6mm] up 1/4" [6mm] down
RUDDER:	3/4" [19mm] right 3/4" [19mm] left	1/2" [13mm] right 1/2" [13mm] left
AILERONS:	5/8" [16mm] up 5/8" [16mm] down	1/4" [6mm] up 1/4" [6mm] down
FLAPS:	Full Rate 3/4" [19mm] down	Half Rate 3/8" [10mm] down

IMPORTANT: The Great Planes Patriot XL has been **extensively** flown and tested to arrive at the throws at which it flies best. Flying your model at these throws will provide you with the greatest chance for successful first flights. If, after you have become accustomed to the way the Great Planes Patriot XL flies, you would like to change the throws to suit your taste, that is fine. However, too much control throw could make the model difficult to control, so remember, "More is not always better."

Balance the Model (C.G.)

More than any other factor, the **C.G.** (balance point) can have the **greatest** effect on how a model flies, and may determine whether or not your first flight will be successful. If you value this model and wish to enjoy it for many flights, **DO NOT OVERLOOK THIS IMPORTANT PROCEDURE.** A model that is not properly balanced will be unstable and possibly unflyable.

At this stage the model should be in ready-to-fly condition with all of the systems in place including the engine, landing gear, covering and paint, and the radio system.

❑1. Use a felt-tip pen or 1/8" [3mm]-wide tape to accurately mark the C.G. on the top of the wing on both sides of the fuselage. **The C.G. is located 9-3/4" [248mm] back from the leading edge of the wing.**

This is where your model should balance for the first flights. Later, you may wish to experiment by shifting the C.G. up to 1/4" [6mm] forward or 1/4" [6mm] back to change the flying characteristics. Moving the C.G. forward may improve the smoothness and stability, but the model may then require more speed for takeoff and make it more difficult to slow for landing. Moving the C.G. aft makes the model more maneuverable, but could also cause it to become too difficult to control. In any case, **start at the recommended balance point** and do not at any time balance the model outside the specified range.

9-3/4" [248mm]

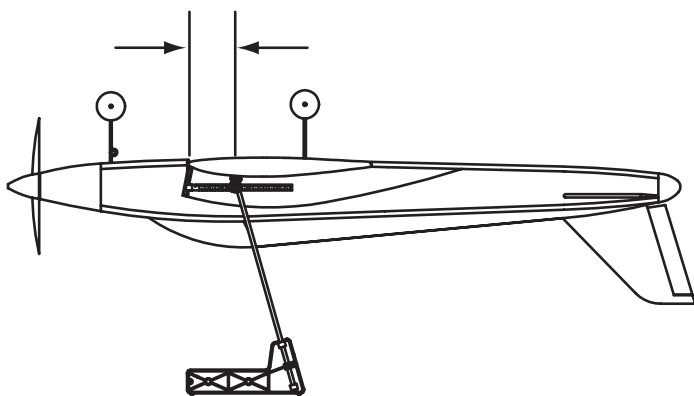

❑2. With the wing attached to the fuselage, all parts of the model installed (ready to fly) and an empty fuel tank, place the model on a Great Planes CG Machine, or lift it at the balance point you marked.

❑3. If the tail drops, the model is "tail heavy" and the battery pack and/or receiver must be shifted forward or weight must be added to the nose to balance. If the nose drops, the model is "nose heavy" and the battery pack and/or receiver must be shifted aft or weight must be added to the tail to

balance. If possible, relocate the battery pack and receiver to minimize or eliminate any additional ballast required. If additional weight is required, nose weight may be easily added by using Great Planes (GPMQ4485) "stick on" lead. A good place to add stick-on nose weight is to the firewall (don't attach weight to the cowl-it is not intended to support weight). Begin by placing incrementally increasing amounts of weight on the bottom of the fuse over the firewall until the model balances. Once you have determined the amount of weight required, it can be permanently attached. If required, tail weight may be added by cutting open the bottom of the fuse and gluing it permanently inside. **NOTE:** Do not rely upon the adhesive on the back of the lead weight to permanently hold it in place. Over time, fuel and exhaust residue may soften the adhesive and cause the weight to fall off. Use #2 sheet metal screws, RTV silicone or epoxy to permanently hold the weight in place.

❑4. **IMPORTANT:** If you found it necessary to add any weight, recheck the C.G. after the weight has been installed.

PREFLIGHT

Identify Your Model

No matter if you fly at an AMA sanctioned R/C club site or if you fly somewhere on your own, you should always have your name, address, telephone number and AMA number on or inside your model. It is **required** at all AMA R/C club flying sites and AMA sanctioned flying events. Fill out the identification tag on the last page of the manual and place it on or inside your model.

Charge the Batteries

Follow the battery charging instructions that came with your radio control system to charge the batteries. You should always charge your transmitter and receiver batteries the night before you go flying, and at other times as recommended by the radio manufacturer.

CAUTION: Unless the instructions that came with your radio system state differently, the **initial** charge on new transmitter and receiver batteries should be done for 15 hours **using the slow-charger that came with the radio system.** This will "condition" the batteries so that the next charge may be done using the fast-charger of your choice. If the initial charge is done with a fast-charger the batteries may not reach their full capacity and you may be flying with batteries that are only partially charged.

NOTE: Checking the condition of your receiver battery pack is **highly recommended.** All battery packs, whether it's a trusty pack you've just taken out of another model, or a new

battery pack you just purchased, should be cycled, noting the discharge capacity. Oftentimes, a weak battery pack can be identified (and a valuable model saved!) by comparing its actual capacity to its rated capacity. Refer to the instructions and recommendations that come with your cycler. If you don't own a battery cycler, perhaps you can have a friend cycle your pack and note the capacity for you.

Balance Propellers



Carefully balance your propeller and spare propellers before you fly. An unbalanced prop can be the single most significant cause of vibration that can damage your model. Not only will engine mounting screws and bolts loosen, possibly with disastrous effect, but vibration may also damage your radio receiver and battery. Vibration can also cause your fuel to foam, which will, in turn, cause your engine to run hot or quit.

We use a Top Flite Precision Magnetic Prop Balancer™ (TOPQ5700) in the workshop and keep a Great Planes Fingertip Prop Balancer (GPMQ5000) in our flight box.

Ground Check

If the engine is new, follow the engine manufacturer's instructions to break-in the engine. After break-in, confirm that the engine idles reliably, transitions smoothly and rapidly to full power and maintains full power indefinitely. After you run the engine on the model, inspect the model closely to make sure all screws remained tight, the hinges are secure, the prop is secure and all pushrods and connectors are secure.

Range Check

Ground check the operational range of your radio before the first flight of the day. With the transmitter antenna collapsed and the receiver and transmitter on, you should be able to walk at least 100 feet away from the model and still have control. Have an assistant stand by your model and, while you work the controls, tell you what the control surfaces are

doing. Repeat this test **with the engine running** at various speeds with an assistant holding the model, using hand signals to show you what is happening. If the control surfaces do not respond correctly, **do not fly!** Find and correct the problem first. Look for loose servo connections or broken wires, corroded wires on old servo connectors, poor solder joints in your battery pack or a defective cell, or a damaged receiver crystal from a previous crash.

ENGINE SAFETY PRECAUTIONS

Failure to follow these safety precautions may result in severe injury to yourself and others.

- Keep all engine fuel in a safe place, away from high heat, sparks or flames, as fuel is very flammable. Do not smoke near the engine or fuel; and remember that engine exhaust gives off a great deal of deadly carbon monoxide. Therefore **do not run the engine in a closed room or garage.**
- Get help from an experienced pilot when learning to operate engines.
- Use safety glasses when starting or running engines.
- Do not run the engine in an area of loose gravel or sand; the propeller may throw such material in your face or eyes.
- Keep your face and body as well as all spectators away from the plane of rotation of the propeller as you start and run the engine.
- Keep these items away from the prop: loose clothing, shirt sleeves, ties, scarfs, long hair or loose objects such as pencils or screwdrivers that may fall out of shirt or jacket pockets into the prop.
- Use a "chicken stick" or electric starter to start the engine. Do not use your fingers to flip the propeller. Make certain the glow plug clip or connector is secure so that it will not pop off or otherwise get into the running propeller.
- Make all engine adjustments from behind the rotating propeller.
- The engine gets hot! Do not touch it during or right after operation. Make sure fuel lines are in good condition so fuel will not leak onto a hot engine, causing a fire.
- To stop a glow engine, cut off the fuel supply by closing off the fuel line or following the engine manufacturer's recommendations. Do not use hands, fingers or any other body part to try to stop the engine. To stop a gasoline powered engine an on/off switch should be connected to the engine coil. Do not throw anything into the propeller of a running engine.

AMA SAFETY CODE (EXCERPT)

Read and abide by the following excerpts from the Academy of Model Aeronautics Safety Code. For the complete Safety Code refer to *Model Aviation* magazine, the AMA web site or the Code that came with your AMA license.

General

- 1) I will not fly my model aircraft in sanctioned events, air shows, or model flying demonstrations until it has been proven to be airworthy by having been previously, successfully flight tested.
- 2) I will not fly my model aircraft higher than approximately 400 feet within 3 miles of an airport without notifying the airport operator. I will give right-of-way and avoid flying in the proximity of full-scale aircraft. Where necessary, an observer shall be utilized to supervise flying to avoid having models fly in the proximity of full-scale aircraft.
- 3) Where established, I will abide by the safety rules for the flying site I use, and I will not willfully and deliberately fly my models in a careless, reckless and/or dangerous manner.
- 5) I will not fly my model unless it is identified with my name and address or AMA number, on or in the model. Note: This does not apply to models while being flown indoors.
- 7) I will not operate models with pyrotechnics (any device that explodes, burns, or propels a projectile of any kind).

Radio Control

- 1) I will have completed a successful radio equipment ground check before the first flight of a new or repaired model.
- 2) I will not fly my model aircraft in the presence of spectators until I become a qualified flier, unless assisted by an experienced helper.
- 3) At all flying sites a straight or curved line(s) must be established in front of which all flying takes place with the other side for spectators. Only personnel involved with flying the aircraft are allowed at or in the front of the flight line. Intentional flying behind the flight line is prohibited.
- 4) I will operate my model using only radio control frequencies currently allowed by the Federal Communications Commission.
- 5) **I will not knowingly operate my model within three miles of any pre-existing flying site except in accordance with the frequency sharing agreement listed [in the complete AMA Safety Code].**
- 9) Under no circumstances may a pilot or other person touch a powered model in flight; **nor should any part of the model other than the landing gear, intentionally touch the ground, except while landing.**

End of AMA Safety Code excerpts.

CHECK LIST

During the last few moments of preparation your mind may be elsewhere anticipating the excitement of the first flight. Because of this, you may be more likely to overlook certain checks and procedures that should be performed before the model is flown. To help avoid this, a checklist is provided to make sure these important areas are not overlooked. Many are covered in the instruction manual, so where appropriate, refer to the manual for complete instructions. Be sure to check the items off as they are completed (that's why it's called a *check list!*).

1. Fuelproof all areas exposed to fuel or exhaust residue
2. Check the C.G. according to the measurements provided in the manual.
3. Be certain the battery and receiver are securely mounted in the fuse. Simply stuffing them into place with foam rubber is not sufficient.
4. Extend your receiver antenna and make sure it has a strain relief inside the fuselage to keep tension off the solder joint inside the receiver.
5. Balance your model laterally as explained on page 37.
6. Use threadlocking compound to secure critical fasteners such as the set screws that hold the wheel axles to the struts, screws that hold the carburetor arm (if applicable), screw-lock pushrod connectors, etc.
7. Add a drop of oil to the axles so the wheels will turn freely.
8. Make sure all hinges are securely glued in place.
9. Reinforce holes for wood screws with thin CA where appropriate (servo mounting screws, cowl mounting screws, etc.).
10. Confirm that all controls operate in the correct direction and the throws are set up according to the manual.
11. Make sure there are silicone retainers on all the clevises and that all servo arms are secured to the servos with the screws included with your radio.
12. Secure connections between servo wires and Y-connectors or servo extensions, and the connection between your battery pack and the on/off switch with vinyl tape, heat shrink tubing or special clips suitable for that purpose.
13. Make sure any servo extension cords you may have used do not interfere with other systems (servo arms, pushrods, etc.).
14. Secure the pressure tap (if used) to the muffler with high temp RTV silicone, thread locking compound or J.B. Weld.
15. Make sure the fuel lines are connected and are not kinked.
16. Use an incidence meter to check the wing for twists and attempt to correct before flying.
17. Balance your propeller (and spare propellers).
18. Tighten the propeller nut and spinner.
19. Place your name, address, AMA number and telephone number on or inside your model.
20. Cycle your receiver battery pack (if necessary) and make sure it is fully charged.
21. If you wish to photograph your model, do so before your first flight.
22. Range check your radio when you get to the flying field.

FLYING

The Great Planes Patriot XL is a great-flying model that flies smoothly and predictably. The Great Planes Patriot XL does not, however, possess the self-recovery characteristics of a primary R/C trainer and should be flown only by experienced R/C pilots.

CAUTION (THIS APPLIES TO ALL R/C AIRPLANES):

If, while flying, you notice an alarming or unusual sound such as a low-pitched "buzz," this may indicate control surface *flutter*. Flutter occurs when a control surface (such as an aileron or elevator) or a flying surface (such as a wing or stab) rapidly vibrates up and down (thus causing the noise). In extreme cases, if not detected immediately, flutter can actually cause the control surface to detach or the flying surface to fail, thus causing loss of control followed by an impending crash. The best thing to do when flutter is detected is to slow the model **immediately** by reducing power, then land as soon as safely possible. Identify which surface fluttered (so the problem may be resolved) by checking all the servo grommets for deterioration or signs of vibration. Make certain all pushrod linkages are secure and free of play. If it fluttered once, under similar circumstances it will probably flutter again unless the problem is fixed. Some things which can cause flutter are; Excessive hinge gap; Not mounting control horns solidly; Poor fit of clevis pin in horn; Side-play of wire pushrods caused by large bends; Excessive free play in servo gears; Insecure servo mounting; and one of the most prevalent causes of flutter; Flying an over-powered model at excessive speeds.

Takeoff

Before you get ready to take off, see how the model handles on the ground by doing a few practice runs at **low speeds** on the runway. If you need to calm your nerves before the maiden flight, shut the engine down and bring the model back into the pits. Top off the fuel, then check all fasteners and control linkages for peace of mind.

Remember to take off into the wind. Gain as much speed as your runway and flying site will practically allow before gently applying up elevator, lifting the model into the air. At this moment it is likely that you will need to apply more right rudder to counteract engine torque. Be smooth on the elevator stick, allowing the model to establish a **gentle** climb to a safe altitude before turning into the traffic pattern.

Flight

For reassurance and to keep an eye on other traffic, it is a good idea to have an assistant on the flight line with you. Tell him to remind you to throttle back once the plane gets to a

comfortable altitude. While full throttle is usually desirable for takeoff, most models fly more smoothly at reduced speeds.

Take it easy with the Great Planes Patriot XL for the first few flights, gradually getting acquainted with it as you gain confidence. Adjust the trims to maintain straight and level flight. After flying around for a while, and while still at a safe altitude with plenty of fuel, practice slow flight and execute practice landing approaches by reducing the throttle to see how the model handles at slower speeds. Add power to see how she climbs as well. Continue to fly around, executing various maneuvers and making mental notes (or having your assistant write them down) of what trim or C.G. changes may be required to fine tune the model so it flies the way you like. Mind your fuel level, but use this first flight to become familiar with your model before landing.

Landing

To initiate a landing approach, lower the throttle while on the downwind leg. Allow the nose of the model to pitch downward to gradually bleed off altitude. Continue to lose altitude, but maintain airspeed by keeping the nose down as you turn onto the crosswind leg. Make your final turn toward the runway (into the wind) keeping the nose down to maintain airspeed and control. Level the attitude when the model reaches the runway threshold, modulating the throttle as necessary to maintain your glide path and airspeed. If you are going to overshoot, smoothly advance the throttle (always ready on the right rudder to counteract torque) and climb out to make another attempt. When you're ready to make your landing flare and the model is a foot or so off the deck, smoothly increase up elevator until it gently touches down.

One final note about flying your model, have a goal or flight plan in mind for **every** flight. This can be learning a new maneuver(s), improving a maneuver(s) you already know, or learning how the model behaves in certain conditions (such as on high or low rates). This is not necessarily to improve your skills (*though it is never a bad idea!*), but more importantly so you do not surprise yourself by impulsively attempting a maneuver and suddenly finding that you've run out of time, altitude or airspeed. Every maneuver should be deliberate, not impulsive. For example, if you're going to do a loop, check your altitude, mind the wind direction (anticipating rudder corrections that will be required to maintain heading), remember to throttle back at the top, and make certain you are on the desired rates (high/low rates). A flight plan greatly reduces the chances of crashing your model just because of poor planning and impulsive moves.

Remember to think.

Have a ball!

But always stay in control and fly in a safe manner.

GOOD LUCK AND GREAT FLYING!

APPENDIX

FLIGHT TRIMMING

Note: The following article has been reprinted in part for future reference and also as a guide for your flight instructor or experienced flying partner to help you with trimming your model. If further information is required, please contact your local hobby dealer, local flying club or call Great Planes at (217) 398-8970

A model is not a static object. Unlike a car, which you can only hunt left or right on the road (technically, a car does yaw in corners, and pitches when the brakes are applied), a plane moves through that fluid we call air in all directions simultaneously. The plane may look like it's going forward, but it could also be yawing slightly, slipping a little and simultaneously climbing or diving a bit! The controls interact. Yaw can be a rudder problem, a lateral balance problem or an aileron rigging problem. We must make many flights, with minor changes between each, to isolate and finally correct the problem.

The chart accompanying this article is intended to serve as a handy field reference when trimming your model. Laminate it in plastic and keep it in your flight box. You just might have need to consult it at the next contest! The chart is somewhat self-explanatory, but we will briefly run through the salient points.

First, we are assuming that the model has been C.G. balanced according to the manufacturer's directions. There's nothing sacred about that spot - frankly, it only reflects the balance point where a prototype model handled the way the guy who designed it thought it should. If your model's wing has a degree more or less of incidence, then the whole balance formula is incorrect for you. But, it's a good ballpark place to start.

The second assumption is that the model has been balanced laterally. Wrap a strong string or monofilament around the prop shaft behind the spinner, then tie the other end to the tail wheel or to a screw driven into the bottom of the aft fuse. Make the string into a bridle harness and suspend the entire model inverted (yes, with the wing on!). If the right wing always drops, sink some screws or lead into the left wing tip, etc. You may be surprised to find out how much lead is needed.

At this point the model is statically trimmed. It's only a starting point, so don't be surprised if you wind up changing it all. One other critical feature is that the ailerons must have their hinge gap sealed. If showing some Scotch tape or Monokote into the hinge gap to prevent the air from slipping from the top of the wing to the bottom, and vice-versa, bothers you, then don't do it.

To achieve the maximum lateral trim on the model, the hinge gap on the ailerons should be sealed. The easiest way to do this is to disconnect the aileron linkages, and fold the ailerons as far over the top of the wing as possible (assuming they are top or center hinged). Apply a strip of clear tape along the joint line. When the aileron is returned to neutral, the tape will be invisible, and the gap will be effectively sealed. Depending on how big the ailerons are, and how large a gaping gap you normally leave when you install hinges, you could experience a 20 percent increase in aileron control response just by this simple measure.

Your first flights should be to ascertain control centering and control feel. Does the elevator always come back to neutral after a 180° turn or Split-S? Do the ailerons tend to hunt a little after a rolling maneuver? Put the plane through its paces. Control centering is either a mechanical thing (binding servos, stiff linkages, etc.), an electronic thing (bad servo resolution or dead band in the radio system), or C.G. (aft Center of Gravity will make the plane wander a bit). The last possibility will be obvious, but don't continue the testing until you have isolated the problem and corrected it.

Let's get down to the task of trimming the model. Use the tachometer every time you start the engine, to insure consistent results. These trim flights must be done in calm weather. Any wind will only make the model weather vane. Each "maneuver" on the list assumes that you will enter it dead straight-and-level. The wings must be perfectly flat, or else the maneuver will not be correct and you'll get a wrong interpretation. That's where your observer comes in. Instruct him to be especially watchful of the wings as you enter the maneuvers.

Do all maneuvers at full throttle. The only deviation from this is if the plane will routinely be flown through maneuvers at a different power setting.

Let's commence with the "engine thrust angle" on the chart. Note that the observations you make can also be caused by the C.G., so be prepared to change both to see which gives the desired result. Set up a straight-and-level pass. The model should be almost hands-off. Without touching any other control on the transmitter, suddenly chop the throttle. Did the nose

drop? When you add power again, did the nose pitch up a bit? If so, you need some down thrust, or nose weight. When the thrust is correct, the model should continue along the same flight path for at least a dozen plane lengths before gravity starts to naturally bring it down.

Do each maneuver several times, to make sure that you are getting a proper diagnosis. Often, a gust, an accidental nudge on the controls, or just a poor maneuver entry can mislead you. The thrust adjustments are a real pain to make. On most models, it means taking the engine out, adding shims, then reassembling the whole thing. Don't take shortcuts.

Don't try to proceed with the other adjustments until you have the thrust line and/or C.G. correct. They are the basis upon which all other trim settings are made.

Also, while you have landed, take the time to crank the clevises until the transmitter trims are at neutral. Don't leave the airplane so that the transmitter has some odd-ball combination of trim settings. One bump of the transmitter and you have lost everything. The trim must be repeatable, and the only sure way to do this is to always start with the transmitter control trims at the middle.

The next maneuver is somewhat more tricky than it looks. To verify C.G., we roll the model up to a 45° bank, then take our hands off the controls. The model should go a reasonable distance with the fuse at an even keel. If the nose pitches down, remove some nose weight, and the opposite if the nose pitches up. The trick is to use only the ailerons to get the model up at a 45° bank. We almost automatically start feeding in elevator, but that's a no-no. Do the bank in both directions, just to make sure that you are getting an accurate reading of the longitudinal balance.

We now want to test the correct alignment of both sides of the elevator (even if they aren't split, like a Pattern ship's, they can still be warped or twisted). Yaw and lateral balance will also come into play here, so be patient and eliminate the variables, one-by-one. The maneuver is a simple loop, but it must be entered with the wings perfectly level. Position the maneuver so that your assistant can observe it end-on. Always loop into the wind. Do several loops, and see if the same symptom persists. Note if the model loses heading on the front or back side of the loop. If you lose it on the way up, it's probably an aileron problem, while a lose of heading on the way back down is most likely a rudder situation.

Note that the Yaw test is the same looping sequences. Here, however, we are altering rudder and ailerons, instead of the elevator halves. We must repeat that many airplanes just will not achieve adequate lateral trim without sealing the hinge gaps shut. The larger you make the loops (to a point), the more discernable the errors will be.

The Lateral Balance test has us pulling those loops very tightly. Pull straight up into a vertical and watch which wing drops. A true vertical is hard to do, so make sure that your assistant is observing from another vantage point. Note that the engine torque will affect the vertical fall off, as will rudder errors. Even though we balance the wing statically before leaving for the field, we are now trimming it dynamically.

The Aileron Coupling (or rigging), is also tested by doing Hammerheads Stalls. This time, however, we want to observe the side view of the model. Does the plane want to tuck under a bit? If so, then try trimming the ailerons down a small bit, so that they will act as flaps. If the model tends to want to go over into a loop, then rig both ailerons up a few turns on the clevises. Note that drooping the ailerons will tend to cancel any washout you have in the wing. On some models, the lack of washout can lead to some nasty characteristics at low speeds.

Again, we reiterate that all of these controls are interactive. When you change the wing incidence, it will influence the way the elevator trim is at a given C.G. Re-trimming the wing will also change the rigging on the ailerons, in effect, and they may have to be readjusted accordingly.

The whole process isn't hard. As a matter of fact it's rather fun - but very time consuming. It's amazing what you will learn about why a plane flies the way it does, and you'll be a better pilot for it. One thing we almost guarantee, is that your planes will be more reliable and predictable when they are properly trimmed out. They will fly more efficiently, and be less prone to doing radical and surprising things. Your contest scores should improve, too.

We wish to acknowledge the Orlando, Florida, club newsletter, from which the basics of the chart presented here were gleaned.

Reprinted in part by Great Planes Model Manufacturing Company, courtesy of Scale R/C Modeler magazine, Pat Potega, Editor, August 1983 issue.

TRIM FEATURE	MANEUVERS	OBSERVATIONS	CORRECTIONS
CONTROL CENTERING	Fly general circles and random maneuvers.	Try for hands off straight and level flight.	Readjust linkages so that Tx trims are centered.
CONTROL THROWS	Random maneuvers	A. Too sensitive, jerky controls. B. Not sufficient control.	If A, change linkages to reduce throws. If B, increase throws.
ENGINE THRUST ANGLE ¹	From straight flight, chop throttle quickly.	A. Aircraft continues level path for short distance. B. Plane pitches nose up. C. Plane pitches nose down.	If A, trim is okay. If B, decrease downthrust. If C, increase downthrust.
CENTER OF GRAVITY LONGITUDINAL BALANCE	From level flight roll to 45-degree bank and neutralize controls.	A. Continues in bank for moderate distance. B. Nose pitches up. C. Nose drops.	If A, trim is good. If B, add nose weight. If C, remove nose weight.
YAW ²	Into wind, do open loops, using only elevator. Repeat tests doing outside loops from inverted entry.	A. Wings are level throughout. B. Yaws to right in both inside and outside loops. C. Yaws to left in both inside and outside loops. D. Yaws right on insides, and left on outside loops. E. Yaws left in insides, and right on outside loops.	If A, trim is correct. If B, add left rudder trim. If C, add right rudder trim. If D, add left aileron trim. If E, add right aileron trim.
LATERAL BALANCE	Into wind, do tight inside loops.	A. Wings are level and plane falls to either side randomly. B. Falls off to left in loops. Worsens as loops tighten. C. Falls off to right in loops. Worsens as loops tighten.	If A, trim is correct. If B, add weight to right wing tip. If C, add weight to left wing tip.
AILERON RIGGING	With wings level, pull to vertical climb and neutralize controls.	A. Climb continues along same path. B. Nose tends to go to inside loop. C. Nose tends to go to outside loop.	If A, trim is correct. If B, raise both ailerons very slightly. If C, lower both ailerons very slightly.

1. Engine thrust angle and C.G. interact. Check both.

2. Yaw and lateral balance produce similar symptoms. Note that fin may be crooked. Right and left references are from the plane's vantage point.

This model belongs to:

Name

Address

City, State Zip

Phone number

AMA number

Two-View Diagram
*Use this drawing for planning
your trim scheme.*

