

EXTRA 300S

Aerobatic .60-Size Sport-Scale Kit

INSTRUCTION MANUAL

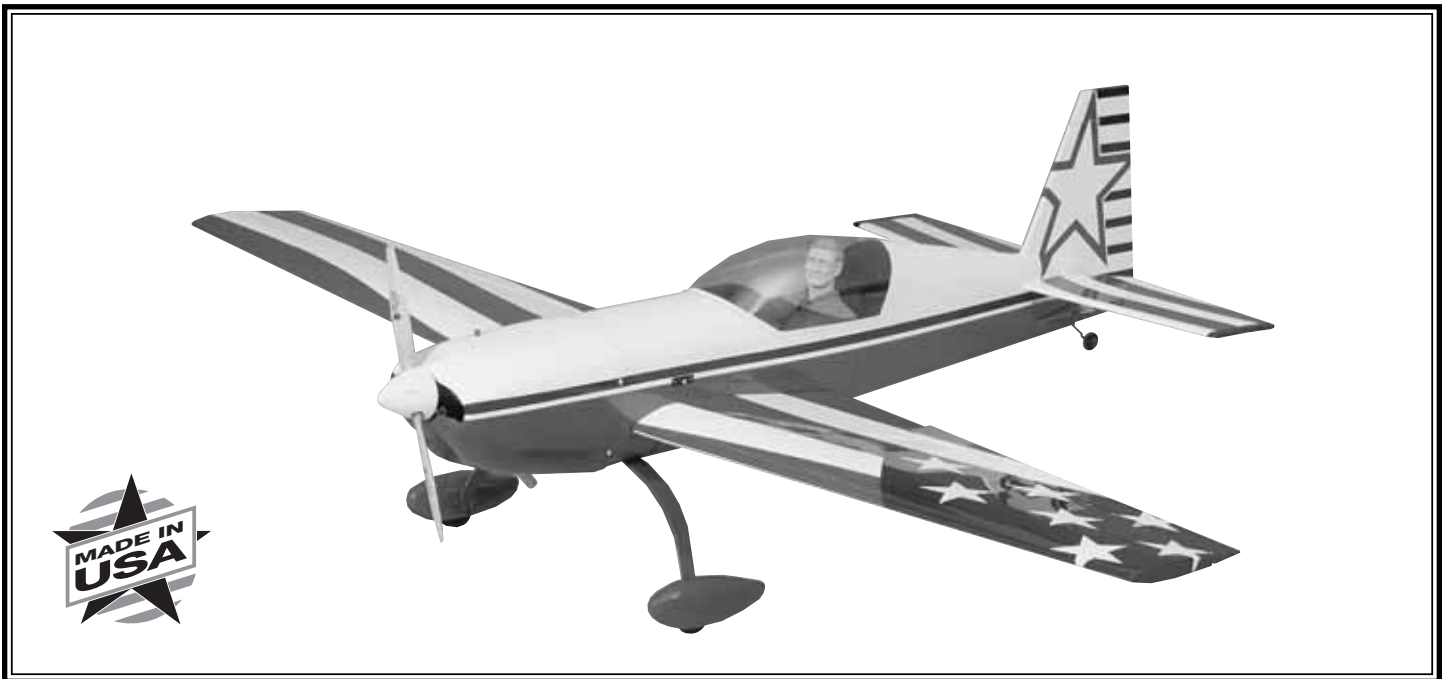

WARRANTY

Great Planes Model Manufacturing Co. guarantees this kit to be free from defects in both material and workmanship at the date of purchase. This warranty does not cover any component parts damaged by use or modification. **In no case shall Great Planes' liability exceed the original cost of the purchased kit.** Further, Great Planes reserves the right to change or modify this warranty without notice.

In that Great Planes has no control over the final assembly or material used for final assembly, no liability shall be assumed nor accepted for any damage resulting from the use by the user of the final user-assembled product. By the act of using the user-assembled product, the user accepts all resulting liability.

If the buyer is not prepared to accept the liability associated with the use of this product, the buyer is advised to return this kit immediately in new and unused condition to the place of purchase.

While this kit has been flight tested to exceed normal use, if the plane will be used for extremely high stress flying, such as racing, the modeler is responsible for taking steps to reinforce the high stress points.

READ THROUGH THIS MANUAL BEFORE STARTING CONSTRUCTION. IT CONTAINS IMPORTANT WARNINGS AND INSTRUCTIONS CONCERNING THE ASSEMBLY AND USE OF THIS MODEL.



P.O. Box 788 Urbana, IL 61803 (217) 398-8970
WWW.GREATPLANES.COM

TABLE OF CONTENTS

Safety Precautions.....	2
Introduction.....	2
Precautions.....	3
Decisions You Must Make.....	3
Engine Selection.....	3
Exhaust System.....	3
Preparations.....	3
Required Accessories.....	3
Building Supplies and Tools.....	4
Optional Tools or Accessories.....	4
Types of Wood.....	4
Common Abbreviations.....	4
Building Notes.....	5
Get Ready to Build.....	5
Inch/Metric Ruler & Conversions.....	5
Die-Cut Patterns.....	6 & 7
Build the Tail Surfaces.....	8
Make the Stab Leading Edge Doubler.....	8
Make the Stab & Fin Sheeting.....	8
Build the Stab.....	9
Elevator Building Sequence.....	10
Fin Building Sequence.....	10
Rudder Building Sequence.....	11
Hinge the Tail Surfaces.....	11
Finish the Tail Surfaces.....	11
Build the Wing.....	12
Build the Wing Spars.....	12
Build the Wing Panels.....	12
Sheet the Center Section.....	14
Servo Mount.....	14
Join the Wing Panels.....	16
Sheet the Top of the Wing.....	18
Build the Ailerons.....	20
Build the Fuselage.....	22
Assemble the Fuselage Formers & Sides.....	22
Assemble the Fuselage.....	23
Mount the Wing to the Fuselage.....	24
Finish the Bottom of the Fuselage.....	27
Build the Front Fuselage Deck.....	29
Mount the Stabilizer to the Fuselage.....	30
Mount the Fin.....	31
Build the Turtle Deck.....	31
Mount the Engine & Tank Tray.....	32
Install the Servos & Make the Pushrods.....	33
Assemble the Wheel Pants.....	36
Assemble the Cowl.....	38
Balance the Model Laterally.....	39
Prepare the Model for Covering.....	39
Cover the Model with MonoKote Film.....	40
Covering Technique.....	40
Suggested Covering Sequence.....	40
Painting.....	40
Final Hookups & Checks.....	41
Join the Control Surfaces.....	41
Install the Hardware.....	41
Attach the Canopy.....	42
Set the Control Throws.....	42
Balance Your Model.....	43
Preflight.....	43
Charge the Batteries.....	43
Balance the Propeller.....	44
Find a Safe Place to Fly.....	44
Ground Check the Model.....	44
Range Check Your Radio.....	44
Engine Safety Precautions.....	44
AMA Safety Code (excerpt).....	45
General.....	45
Radio Control.....	45
Flying.....	45
Takeoff.....	45
Flying.....	46
Landing.....	46
2-View Drawing.....	47
Flight Log.....	48
Fuse & Wing Plans w/Parts List.....	Center Pull-Out Section

PROTECT YOUR MODEL, YOURSELF & OTHERS...FOLLOW THIS IMPORTANT SAFETY PRECAUTION

Your Extra 300S is not a toy, but a sophisticated, working model that functions very much like a full-size airplane. Because of its realistic performance, the Extra, if not assembled and operated correctly, could possibly cause injury to yourself or spectators and damage property.

If this is your first sport model, we recommend that you get help from an experienced, knowledgeable modeler with your first flights. You'll learn faster and avoid risking your model before you're ready to take the controls for yourself.

You may also contact the national Academy of Model Aeronautics (AMA), which has more than 2,500 chartered clubs across the country. Contact AMA at the address or toll-free phone number below:



Academy of Model Aeronautics

5151 East Memorial Drive
Muncie, IN 47302-9252
Tele. (800) 435-9262
Fax (765) 741-0057

Or via the internet at: <http://www.modelaircraft.org>

INTRODUCTION

Congratulations and thank you for purchasing the Great Planes Extra 300S. We've selected the "S" because we feel it looks the best and it is truly meant to perform aerobatics. Among a few versions of the Extra 300 out there, another popular one is the "L" which accommodates two passengers—one student and one flight instructor.

The Extra is a rather "square shaped" airplane with well defined lines. Coincidentally, this makes it exceptionally easy to build and cover—especially for a semi-scale sport model. Framing the model is very straightforward as most of the structure features interlocking balsa and lite-ply. The turtle deck sheeting may look a little intimidating but in actuality it is quite easy to apply if you follow the instructions and use the template provided to cut the sheeting.

Flying the Extra 300S is a thrilling experience—as it should be for such an aerobatic model! It doesn't take much elevator or aileron throw to put the Extra through its paces. When you have a feel for your Extra 300S, the throws can be increased to high rates (illustrated in the instructions) to really showcase the aerobatic potential. The Extra performs surprisingly well on a ball bearinged, Schnuerle ported .61,

and even better with a .91 4-stroke, but seasoned experts will surely want to get the most out of the Extra by strapping on a .91 2-stroke or a 1.20 4-stroke.

We hope you enjoy building and flying your Great Planes Extra 300S as much as we did flying the prototypes.

PRECAUTIONS

1. Build the model according to the plans and instructions. Do not alter or modify the model, as doing so may result in an unsafe or unflyable model. In a few cases the plans and instructions may differ slightly from the photos. In those instances the plans and written instructions should be considered as correct.
2. Take time to build straight, true and strong.
3. Use an R/C radio system that is in first-class condition, and a correctly-sized engine and components (fuel tank, wheels, etc.), throughout your building process.
4. Properly install all components so that the model operates properly on the ground and in the air.
5. Check the operation of the model before **every** flight to insure that all equipment is operating correctly and that the model has remained structurally sound. Be sure to check nylon clevises or other connectors often and replace them if they show signs of wear or fatigue.
6. If you are not already an experienced R/C pilot, you must fly the model only with the help of a competent, well experienced R/C pilot.

NOTE: We, as the kit manufacturer, provide you with a top quality kit and great instructions, but ultimately the quality of your finished model depends on how you build it; therefore, we cannot in any way guarantee the performance of your completed model, and no representations are expressed or implied as to the performance or safety of your completed model.

Remember: Take your time and follow directions to end up with a well-built model that is straight and true. Please inspect all parts carefully before starting to build! If any parts are missing, broken or defective, or if you have any questions about building or flying this model, please call us at (217) 398-8970 and we'll be glad to help. If you are calling for replacement parts, please reference the part numbers and the kit identification number (stamped on the end of the carton) and have them ready when calling.

We can also be reached by E-Mail at:

productsupport@greatplanes.com

DECISIONS YOU MUST MAKE

Engine Selection

There are several engines that will work well in your Extra 300S, but for unlimited performance we recommend a *hot* 2-stroke such as an **O.S.® .91FX** or **SuperTigre™ G90**. If you prefer a 4-stroke, an **O.S. .91 Surpass™** works well and the **O.S. 1.20 Surpass** makes unlimited vertical lines a part of every flight experience. Your choice of 2-stroke or 4-stroke will determine the location of the pushrod exit on the firewall, so plan ahead.

Exhaust System

If you choose to use a 2-stroke engine, you will need an in-cowl muffler for the best appearance. On our prototype Extra 300S with the **O.S. .61FX**, we used the **Slimline #3217 Pitts Muffler (SLIG2217)**. With the **O.S. Surpass .91 and Surpass 1.20**, we used the stock muffler included with the engines. The Hobbico exhaust extension allows the stock muffler to fit inside the cowl.

PREPARATIONS

Required Accessories

Items in parentheses (GPMQ4243) are suggested part numbers recognized by distributors and hobby shops and are listed for your ordering convenience. GPM is the Great Planes brand, TOP is the Top Flite® brand, and HCA is the Hobbico® brand.

- Four-channel radio with five servos (Optional 6th servo for twin elevator servos)
- Engine – See **Engine Selection** above
- Exhaust – See **Exhaust System** above
- Spare glow plugs (O.S. #8 for most 2-stroke engines, OSMG2691, O.S. Type-F for most 4-stroke engines, OSMG2692)
- Propeller (Top Flite® Power Point™); Refer to your engine's instructions for proper size
- Top Flite Super MonoKote® covering (2 to 3 rolls) – See **Covering** (page 40)
- Fuelproof paint, See **Painting** (page 40)
- Fuel tank 12 oz. (GPMQ4105)
- 3" Medium fuel tubing (GPMQ4131)
- 1/4" Latex foam rubber padding (HCAQ1000)
- 1/16" Foam wing seating tape (GPMQ4422)
- (2) 2-3/4" Wheels (GPMQ4224)
- (1) 3/16" Wheel collar (GPMQ4308)
- 2-1/2" Spinner (GPMQ4520, White)
- Pilot (DGA® 1/4 scale sportsman pilot used in prototype, DGAQ2010)
- Fueling system (Great Planes Easy Fueler™, GPMQ4160)
- Pacer Formula 560 canopy glue (PAAR3300)

Building Supplies and Tools

These are the building tools, glue, etc., that we recommend and mention in the manual.

We recommend Great Planes **Pro™ CA and Epoxy.**

- 2 oz. Pro CA (Thin, GPMR6003)
- 2 oz. Pro CA+ (Medium, GPMR6009)
- 1 oz. Pro CA+ (Thick, GPMR6014)
- 6-Minute Pro Epoxy (GPMR6045)
- 30-Minute Pro Epoxy (GPMR6047)
- CA accelerator (GPMR6035)
- Hand or electric drill
- Hobby knife handle (HCAR0105, #11 Blades HCAR0311)
- Razor Saw
- Pliers (Common and Needle Nose)
- Screwdrivers (Phillips and flat blade)
- Small T-pins (HCAR5100)
- Medium T-pins (HCAR5150)
- Masking tape (TOPR8018)
- Bar sander or sanding block and sandpaper (coarse, medium, fine grit)
- Easy-Touch™ (or similar)
- Plan Protector (GPMR6167) or waxed paper
- Lightweight balsa filler such as Hobbico® HobbyLite™ (Hobbico HCAR3401)
- Monofilament string for aligning wing & stabilizer
- 90° Building square (HCAR0480)
- Builders triangle set (HCAR0480)
- 1/4-20 Tap (GPMR8105, drill bit included)
- Electric power drill
- Sealing iron (TOPR2100)
- Heat gun (TOPR2000)
- Drill bits: 1/16", 5/64", 3/32", 7/64", 1/8", 5/32", #18 or 11/64", 3/16", #10 or 13/64", 7/32", 1/4", 17/64"



On our workbench, we have three 11" **Great Planes Easy-Touch Bar Sanders**, equipped with 80, 150 and 220-grit sandpaper. This setup is all that is required for almost any sanding task. We also keep some 320-grit wet-or-dry sandpaper handy for finish sanding before covering.



Great Planes **Easy-Touch Bar Sanders** are made from lightweight extruded aluminum and can be found at most

hobby shops. They are available in five sizes – 5-1/2" (GPMR6169) for those tight, hard-to-reach spots; 11" (GPMR6170) for most general purpose sanding; and 22" (GPMR6172), 33" (GPMR6174) and 44" (GPMR6176) for long surfaces such as wing leading edges. The **Easy-Touch Adhesive-Backed Sandpaper** comes in 2" x 12' rolls of 80-grit (GPMR6180), 150-grit (GPMR6183), 180-grit (GPMR6184) and 220-grit (GPMR6185) and an assortment of 5-1/2" long strips (GPMR6189) for the short bar sander. The adhesive-backed sandpaper is easy to apply and remove from your sanding bar when it's time for replacement.

Custom sanding blocks can be made from balsa or hardwood blocks and sticks for sanding difficult or hard to reach spots.

Optional Tools or Accessories

- CA Applicator tips (HCAR3780)
- Epoxy brushes (GPMR8060)
- Epoxy mixing sticks (GPMR8055, Qty. 50)
- CA Debonder (GPMR6039)
- Trim seal tool (TOPR2200)
- Hot Sock™ (TOPR2175)
- Razor plane (MASR1510)
- Single-edge razor blades (HCAR0312)
- Straightedge (Hobbico Non-Slip, HCAR0475)
- Denatured or isopropyl alcohol (for epoxy clean-up)
- Dremel® Moto-Tool® or similar
- Cut-off wheel w/mandrel (GPMR8200)
- Curved tip canopy scissors (HCAR0667)

Types of Wood

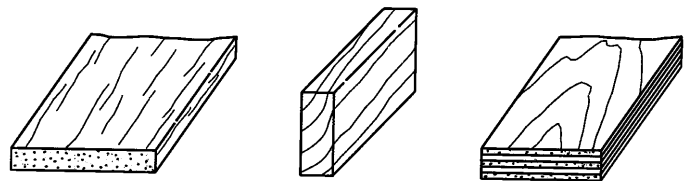

Balsa

Basswood

Plywood

Common Abbreviations

- | | |
|---------------------------|--------------------|
| Elev = Elevator | Fuse = Fuselage |
| LE = Leading Edge (front) | LG = Landing Gear |
| Ply = Plywood | Stab = Stabilizer |
| TE = Trailing Edge (rear) | " = Inches |
| Bass = Basswood | Fin = Vertical Fin |

Building Notes

There are two types of screws used in this kit:

Sheet metal screws are designated by a number and a length. For example #6 x 3/4"

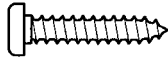

Machine screws are designated by a number, threads per inch and a length. For example 4-40 x 3/4"



When you see the term "**test fit**" in the instructions, it means you should first position the part on the assembly **without using any glue** and then slightly modify or sand the part as necessary for the best fit.

Whenever the instructions tell you to **glue** pieces together, CA or epoxy may be used. When a **specific** type of glue is required, the instructions will state the type of glue that is **highly recommended**. When 30-minute epoxy is specified, it is highly recommended that you use only 30-minute epoxy because you will need the working time and/or the additional strength.

Several times during construction we refer to the "top" or "bottom" of the model or a part of the model. For example, during wing construction we tell you to "glue the top main spar" or during fuse construction "trim the bottom of the former." It is understood that the "top" or "bottom" of the model is as it would be when the airplane is right side up and will be referred to as the "top" even if the model is being worked on upside-down (i.e. the "top" main spar is always the "top" main spar, even when the wing is being built upside-down).

Get Ready to Build

1. Unroll the plan sheet. Reroll the plan sheet inside out to make it lie flat. Place wax paper or a Great Planes Plan Protector™ over the area of plan you are working on to prevent glue from sticking to the plan. Use tape or tacks to hold the plan and protector securely in place.

2. Remove all parts from the box. As you do, determine the name of each part by comparing it with the **plan** and the **parts list** included with this kit. Using a felt-tip or ballpoint pen, lightly write the part **name** or **size** on each piece to avoid confusion later. Use the die-cut patterns shown on pages 6 and 7 to identify the die-cut parts and mark them **before** removing them from the sheet. **Save all leftovers**. If any of the die-cut parts are difficult to remove, do not force them! Instead, cut around the parts with a hobby knife. After punching out the die-cut parts, use your Easy-Touch Bar Sander or sanding block to **lightly** sand the edges to remove any die-cutting irregularities or slivers.

3. As you identify and mark the parts, separate them into groups, such as **fuse** (fuselage), **wing**, **fin**, **stab** (stabilizer) and **hardware**.



Zipper-top food storage bags are handy to store small parts as you sort, identify and separate them into sub-assemblies.

Metric Conversions

1/64" =	.4 mm
1/32" =	.8 mm
1/16" =	1.6 mm
3/32" =	2.4 mm
1/8" =	3.2 mm
5/32" =	4.0 mm
3/16" =	4.8 mm

1/4" =	6.4 mm
3/8" =	9.5 mm
1/2" =	12.7 mm
5/8" =	15.9 mm
3/4" =	19.0 mm
1" =	25.4 mm
2" =	50.8 mm
3" =	76.2 mm

6" =	152.4 mm
12" =	304.8 mm
18" =	457.2 mm
21" =	533.4 mm
24" =	609.6 mm
30" =	762.0 mm
36" =	914.4 mm

Inch Scale

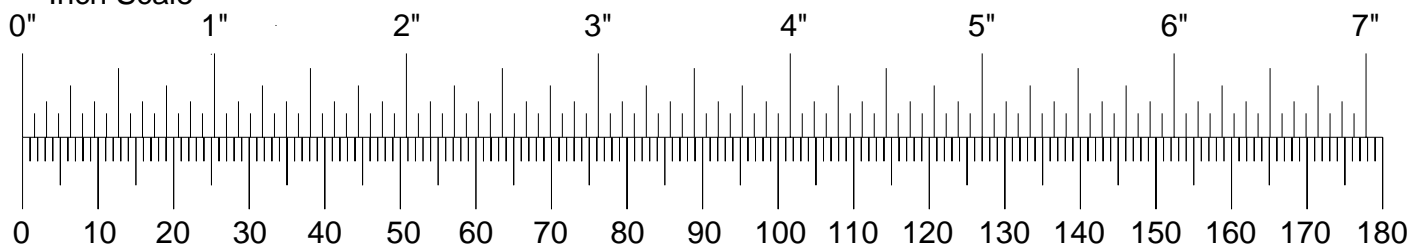

DIE-CUT PATTERNS

EXT6F05 1 per kit

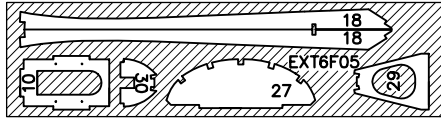

1/8" x 4-1/8" x 15-3/4" ply

EXT6F04 1 per kit

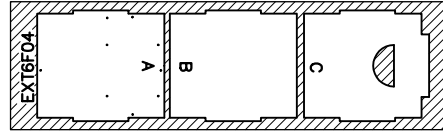

1/8" x 4-5/8" x 15-3/4" ply

EXT6F06 1 per kit

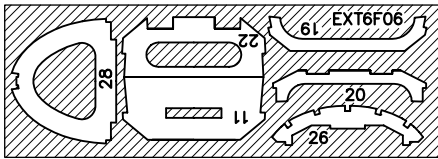

1/8" x 5-1/2" x 15-3/4" ply

EXT6F03 1 per kit

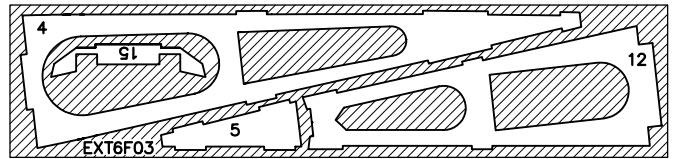

1/8" x 5-1/2" x 23-3/4" ply

EXT6F08 1 per kit

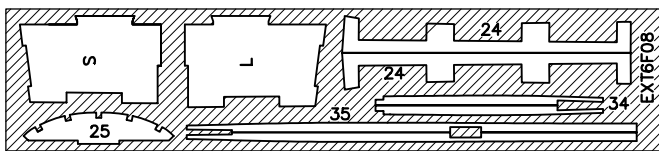

1/8" x 5-1/8" x 23-3/4" ply

EXT6F02 1 per kit

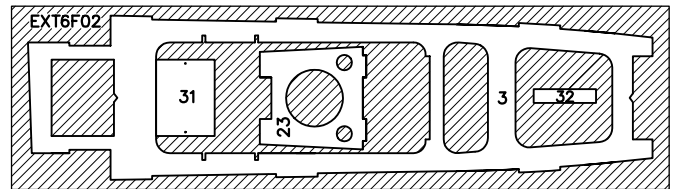

1/8" x 6-5/8" x 23-3/4" ply

EXT6F01 2 per kit

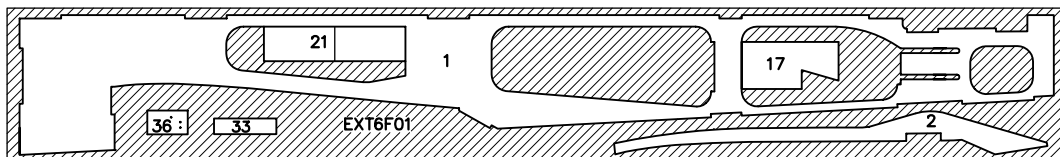

1/8" x 5-1/2" x 38-1/4" ply

DIE-CUT PATTERNS

EXT6F07

1 per kit

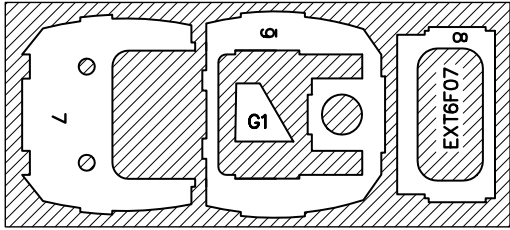

1/8" x 7" x 15-3/4" ply

EXT6F09

1 per kit

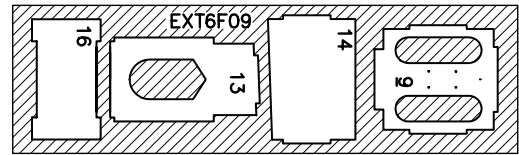

1/8" x 4-5/8" x 15-3/4" ply

EXT6W01

2 per kit

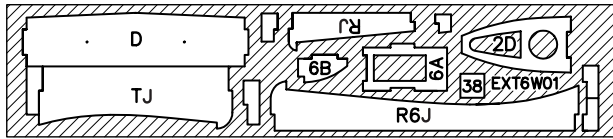

1/8" x 4-1/8" x 19" ply

EXT6W02

2 per kit

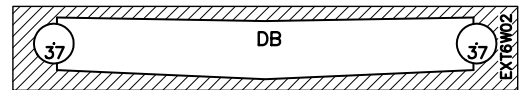

1/16" x 2-5/8" x 15-3/4" ply

EXT6W03

2 per kit

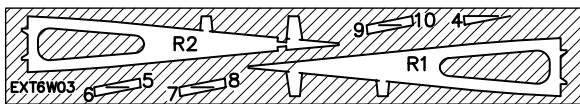

3/32" x 3" x 18" balsa

EXT6W04

2 per kit

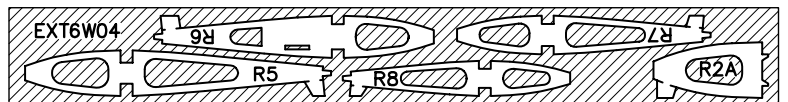

3/32" x 3" x 24" balsa

EXT6W05

2 per kit

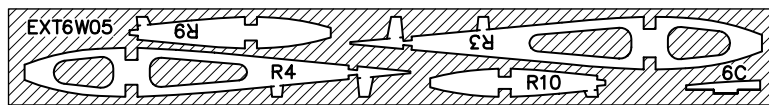

3/32" x 3" x 24" balsa

BUILD THE TAIL SURFACES

Make the Stab Leading Edge Doubler

You may remove the stabilizer and elevator drawing from the wing plan by cutting along the dashed line. Don't forget to cover the plan with a Great Planes Plan Protector so the glue won't stick to the plan.

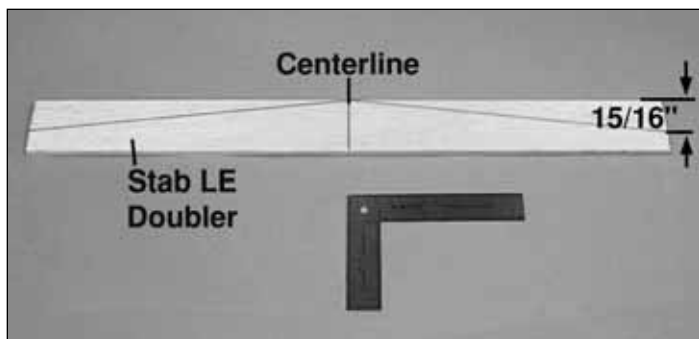

❑ 1. From the 3/16" x 1-1/2" x 24" balsa sheet cut down to 15". Use a ballpoint pen and a draftsman's square to *accurately* mark the centerline of the 15" balsa sheet **stab LE doubler**. Use your pen to make a mark on each end of the doubler 15/16" from the LE.

❑ 2. Use a straightedge to draw lines connecting the centerline of the stab LE doubler with the marks on the ends as shown in the photo.

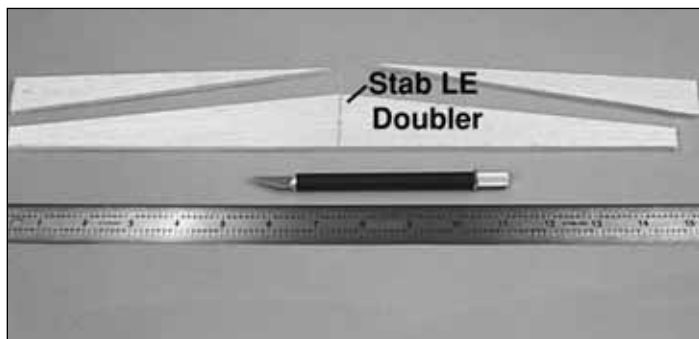

❑ 3. Use a hobby knife with a sharp #11 blade to cut along the lines you drew. If necessary, use a bar sander to true the leading edges you just cut.

❑ 4. Use the plan as a guide to mark and cut the bevel on both ends of the **stab LE doubler**.

Make the Stab & Fin Sheeting

❑ 1. See the Expert Tip that follows, then glue three 1/16" x 3" x 30" balsa sheets together. This will be cut in half lengthwise creating the sheeting for the stab.



HOW TO JOIN SHEETING

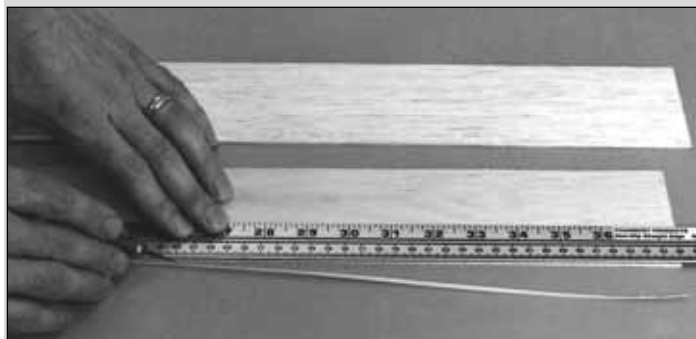

A. Use a metal straightedge as a guide to trim one edge of both sheets.



B. Use masking tape to tightly tape the two sheets together joining the trimmed edges.



C. Turn the sheet over and place weights on top of the sheet to hold it. Apply thin CA sparingly to the seam between the two places, quickly wiping away excess CA with a paper towel as you proceed.

D. Turn the sheet over and remove the masking tape, then apply thin CA to the seam the same way you did for the other side.

E. Sand the sheet flat and smooth with your bar sander and 150-grit sandpaper.

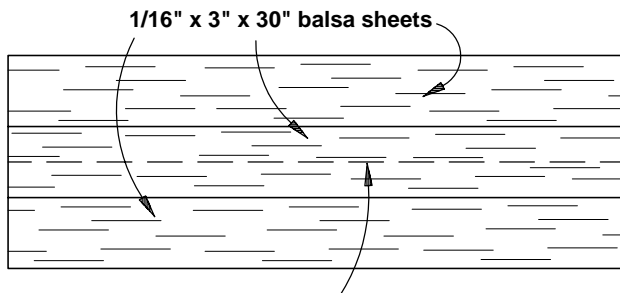

Cut down the middle to make two 4-1/2" sheets.

- ❑ 2. Cut the sheet you have made in half making two sheets 4-1/2" x 30" **stab sheets**.

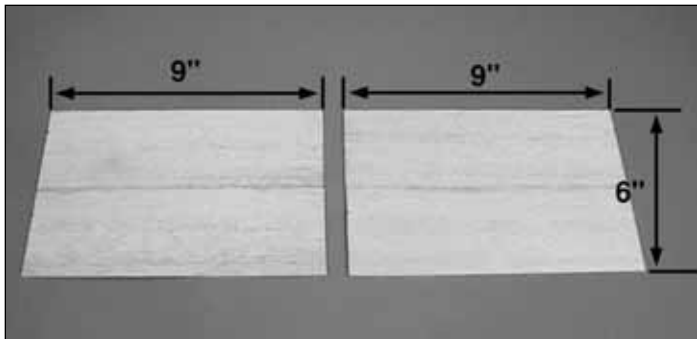

- ❑ 3. Cut the 1/16" x 3" x 36" balsa sheet into four 9" sheets. Edge glue two of them together to make two sets of 1/16" x 6" x 9" **fin sheets**.

Build the Stab

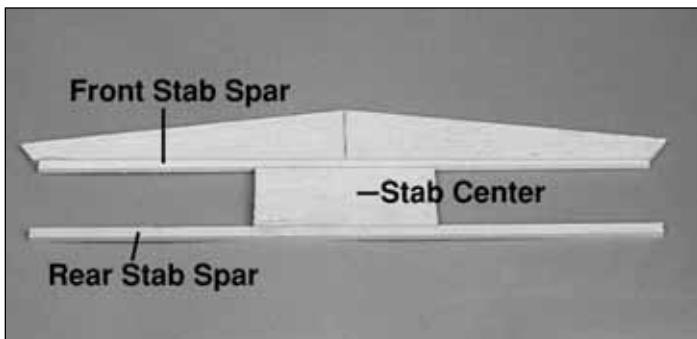

- ❑ 1. Pin the **stab LE doubler** in position over the plan. Fit and glue a 3/16" x 3/16" x 14" basswood **front stab spar**, to the back of the stab LE doubler. Wipe away excess CA before it cures.

Note: Refrain from using excessive accelerator. Even hours after it's sprayed on, residual accelerator can prematurely and unexpectedly cure the CA you use later on nearby glue joints. Unless you must handle or remove the part from your building board right away we recommend using no accelerator at all.

- ❑ 2. Test fit the 3/16" x 1-7/8" x 4" balsa **stab center** in place. You will need to trim the stab center down for a perfect fit. When happy with the fit, glue it to the 3/16" stab spar.

- ❑ 3. Fit and glue the 3/16" x 3/16" x 14" basswood **rear stab spar** to the rear of the stab center.

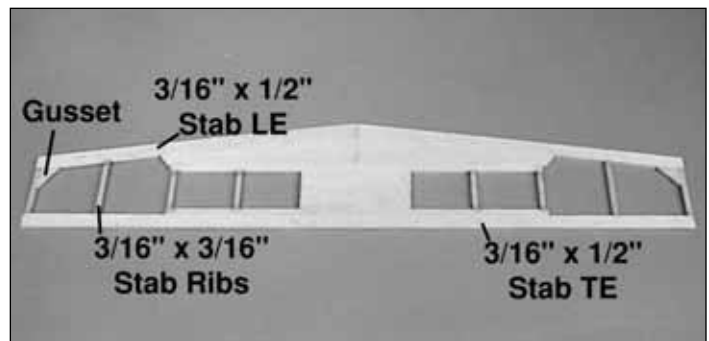

- ❑ 4. Glue the 3/16" x 1/2" x 30" balsa **stab TE** in place.
- ❑ 5. Using two 3/16" x 1/2" x 14" balsa sticks, fit and glue the **LE** on the stab. Save the ends of the LE sticks for the gussets at the outer LE corners.
- ❑ 6. From a 3/16" x 3/16" x 36" balsa stick, fit and glue the eight **stab ribs** in place.
- ❑ 7. Using the leftover pieces you saved from the LE stick, fit and glue two tip gussets in place.
- ❑ 8. Use your bar sander or a large sanding block and 220-grit sandpaper to sand the entire top and bottom surface of the stab framework until it is flat and even. Be careful while sanding so you do not over-thin any one particular area of the stab or gouge the stab cross braces by snagging the sandpaper on them.

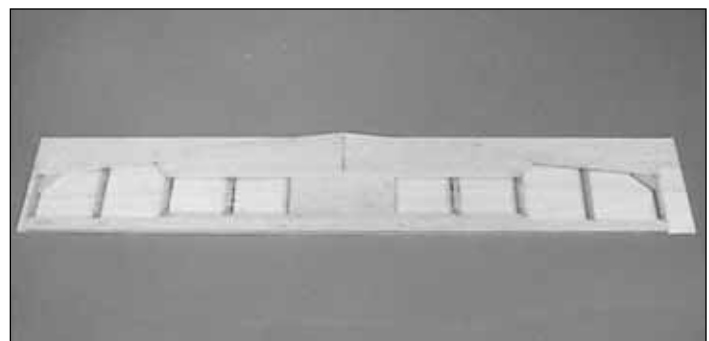

- ❑ 9. Using medium CA, Glue the stab framework to one of the stab sheets you made earlier, aligning the sheeting parallel to the TE of the stab. Give the CA ample time to cure before lifting the assembly off the work bench.

Note: It is essential to get a very secure and uniform bond between the stab sheets and the stab core, especially in the center.

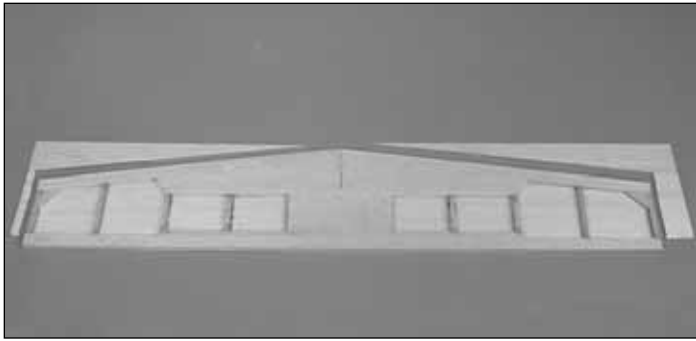

☐☐ 10. Place the sheeted side of the stab on your work bench and trim the sheeting around the outer edges of the framework.

☐☐ 11. Repeat steps 9 and 10 to sheet the remaining side of the stab.

Elevator Building Sequence

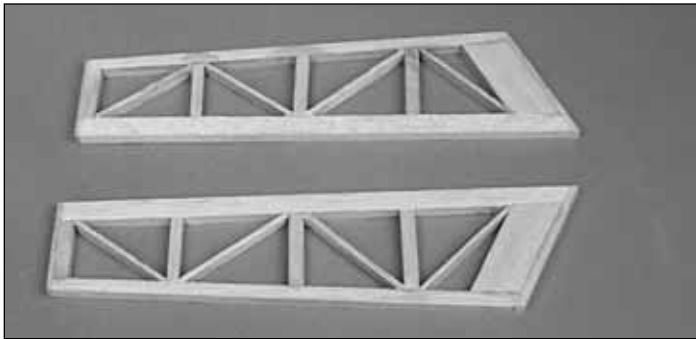

☐☐ 1. Make the LE using a 5/16" x 1/2" x 14" balsa stick (leave 1/16" of length at both ends).

☐☐ 2. Make the root end, cut from a 5/16" x 1" x 12" balsa stick.

☐☐ 3. Make the TE using a 5/16" x 5/16" x 36" balsa stick (leave 1/16" of length at both ends).

☐☐ 4. Make the tip and ribs using a 5/16" x 5/16" x 36" stick.

☐☐ 5. Make the diagonal ribs using a 1/8" x 5/16" x 36" balsa stick.

☐☐ 6. Remove the elevator from the plan and inspect all glue joints. Add CA where necessary. Sand the LE and TE flush with ends.

☐☐ 7. Add 1/8" balsa to both ends of the elevator. Sand flat and smooth with a bar sander and 220-grit sandpaper.

☐☐ 8. Build the second elevator the same as the first.

Fin Building Sequence

Note: Because it is not necessary to build on the fuse plans we reduced them to 75% so that they are easier to use as a reference while building the fuse. **Make sure to build the fin and rudder over the full-size drawing, not the reduced plan.**

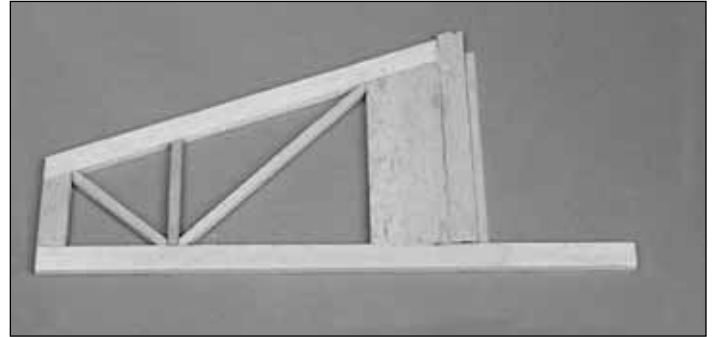

☐ 1. Make the LE and TE using 3/16" x 1/2" x 14" balsa sticks.

☐ 2. Make the fin tip using the 3/16" x 1/2" balsa stick remaining from step A.

☐ 3. Make the fin base using the leftover 3/16" x 1-1/2" x 9" stick remaining from the stab LE doubler assembly.

☐ 4. Make the 3/16" fin ribs and cross trusses using the leftover 3/16" x 3/16" stick from the stab rib assembly.

☐ 5. From 3/16" x 3/16" balsa fit and glue the bottom key in place.

☐ 6. Remove the fin from your building board and inspect all the glue joints. Add CA where necessary. Use your bar sander to sand the top of the leading and trailing edges even with the tip of the fin. Sand the bottom of the leading edge even with the base. Sand the entire fin flat and smooth with your bar sander and 220-grit sandpaper.

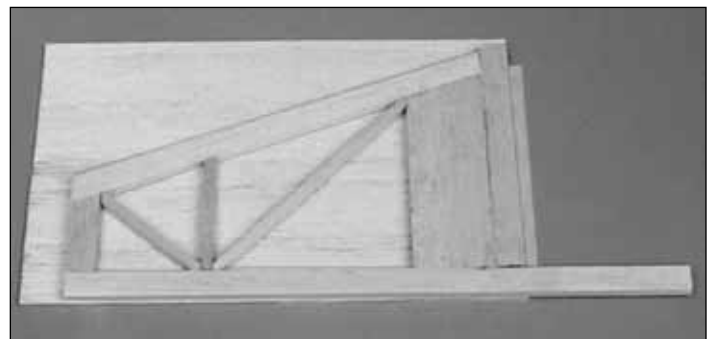

☐ 7. Sheet both sides of the fin with the 1/16" fin sheets you made earlier using the same technique you did with the stab.

☐ 8. From leftover 1/16" sheeting, sheet the fin post.

☐ 9. Trim and sand the sheeting flush with the framework.

Rudder Building Sequence

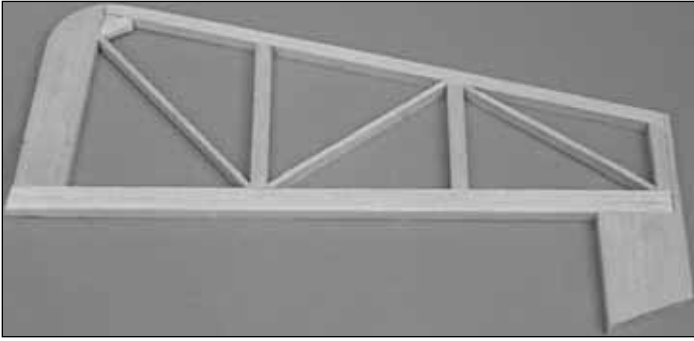

1. Make the LE using a 5/16" x 1/2" x 14" balsa stick (leave 1/16" of length at both ends).
2. Make the balance tab using 5/16" x 1-1/2" x 2-3/4" balsa sheet.
3. Make the rudder bottom from the remaining piece of 5/16" x 1" stick leftover from the elevator root assembly.
4. Make the TE from the 5/16" x 5/16" stick leftover from the elevator TE assembly.
5. Make three rudder ribs using the remainder of the 5/16" x 5/16" x 36" balsa stick.
6. Make the cross trusses and rudder top cap from the remaining piece of 1/8" x 5/16" remaining from the elevator assembly.
7. Using a leftover piece from the LE, glue the corner gusset in place.
8. Inspect all the glue joints and add CA where necessary. Shape the bottom of the rudder as shown on the plan. Sand the entire rudder flat and smooth with your bar sander.

Hinge the Tail Surfaces

1. Place the stab over its location on the plan and *lightly* mark the hinge locations on the trailing edge with a ballpoint pen. Mark the hinge locations on the elevators using the same procedure.

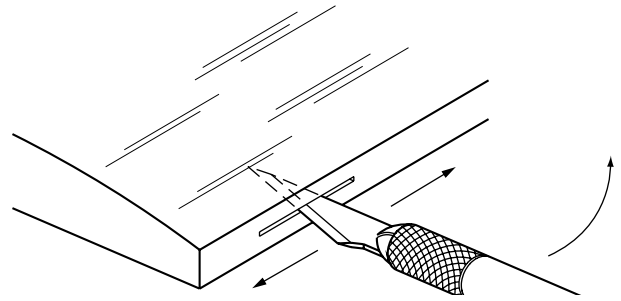

2. Cut the hinge slots in the elevator and stabilizer using a #11 blade. Begin by **carefully** cutting a very shallow slit at the hinge location to accurately establish the hinge slot. Make three or four more cuts going a little deeper each time. As you cut, slide the knife from side to side until the slot has reached the proper depth and width for the hinge.

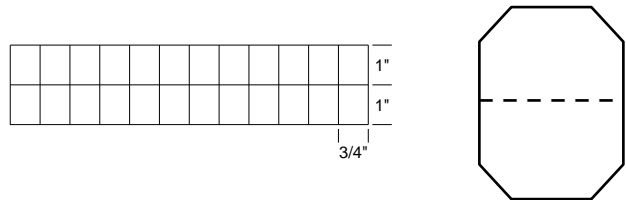

3. Cut twenty four 3/4" x 1" hinges for the elevators and rudder from the supplied 2" x 9" **hinge material**, then snip off the corners. Temporarily join the elevators to the stab with the hinges, adjusting any hinge slots if necessary so they all align. **Do not glue the hinges in place until you are instructed to do so.**
4. Return to step 1 and use the same procedures to hinge the rudder and fin.

Finish the Tail Surfaces

1. Shape the leading edge of the elevators to a "V" as shown on the plan using a razor plane and bar sander.
2. Use the same procedure to bevel the leading edge of the rudder. It will be necessary to sand the bevel at the top of the rudder hinge line using your sanding block, because the balance tab will not allow the razor plane to go the full length.
3. Use your bar sander and 150-grit sandpaper to round the tail surfaces as shown on the fuse plan.

That's about it for the tail surfaces. They're a little more work than sheet surfaces but they are much lighter, just as strong, and a nice piece of craftsmanship. Clean off your work bench and get ready for the wing!

BUILD THE WING

Note: The following instructions explain how to build the wing directly over the plans. We'll start by building the left wing panel upside-down over the left wing panel plan so your progress matches the photos.

Build the Wing Spars

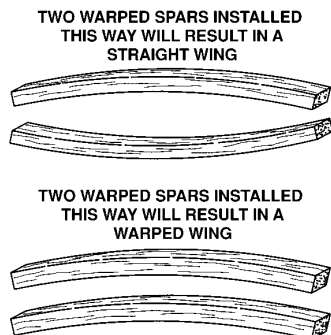

❑ 1. Before using the 1/4" x 3/8" x 32" basswood **spars**, examine them carefully for possible imperfections. Look for knots, soft spots, diagonal grain and any other imperfections. If possible, position each spar so the imperfections (if any) are on the outer half of the wing panel (toward the tip), where they will be least affected by high stresses. If the spars are warped slightly, try to "balance them out" by installing the warped spars in opposite directions (see sketch).

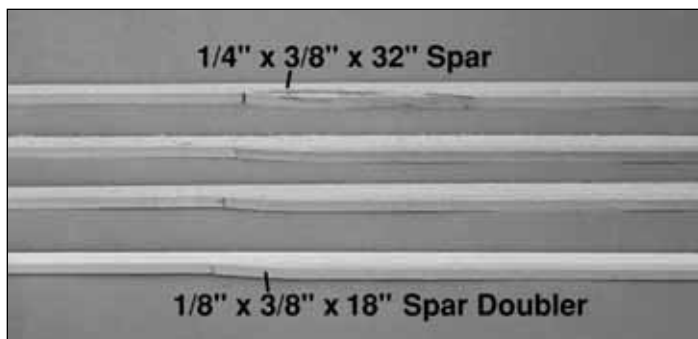

❑ 2. Find the 1/8" x 3/8" x 18" basswood sticks. Cut the sticks down to 15-3/4" making the **spar doublers**. Sand one end of each of the four spar doublers to a taper as shown on the plan. Glue the spar doublers to the spars and sand off any excess glue.

❑ 3. Carefully press out all the die-cut 3/32" balsa **wing ribs**. Sand the edges **slightly** to remove any die-cutting irregularities.

Build the Wing Panels

❑ 1. Tape the left wing plan to your flat work surface, and cover the wing drawing with Great Planes Plan Protectors (so you won't glue the wing to the plan!).

❑ 2. Cross pin a **top spar** to the plan with the doubler up and toward the root. **Note:** The spars are cut slightly too long. Align them at the root and leave the excess past the tip rib.



❑ 3. Glue ribs R3 to R10 to the top spar over their locations shown on the plan, using rib gauge **G1** to set the ribs at the correct angle. **Note:** One angle on G1 is used as a rib angle guide and the other angle on it is used for setting the cockpit rear former at the correct angle.

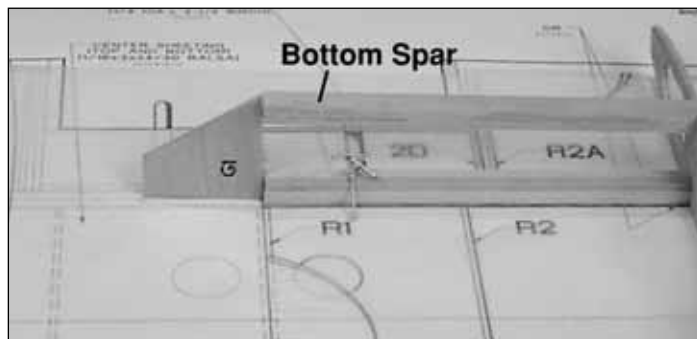

❑ 4. Place the bottom spar into the rib notches, and use G1 to position the root end of the spar. When satisfied with the fit, glue the spar to the ribs with thin CA.

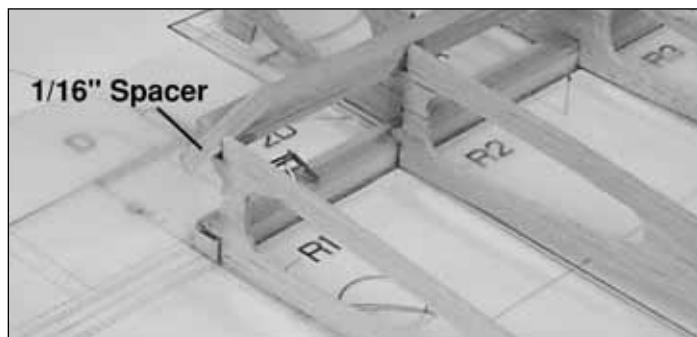

❑ 5. Glue **R1**, **R2** and **R2A** in place using a leftover piece of 1/16" ply as a spacer to locate the ribs 1/16" away from the spars. Do not glue the spacer while gluing the ribs.

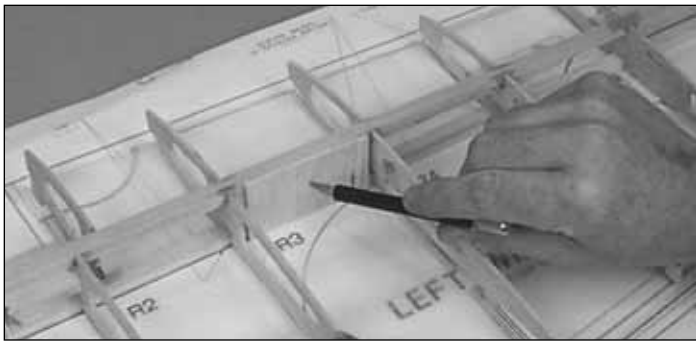

6. From a $\frac{3}{32}$ " x 3" x 24" balsa sheet, make shear webs to fit from ribs R3 through R8, with an additional web aft of the spars between R3 and R4. **Hint:** Use a #11 hobby knife to hold the cut shear webs while putting glue on the web and put the webs in place.

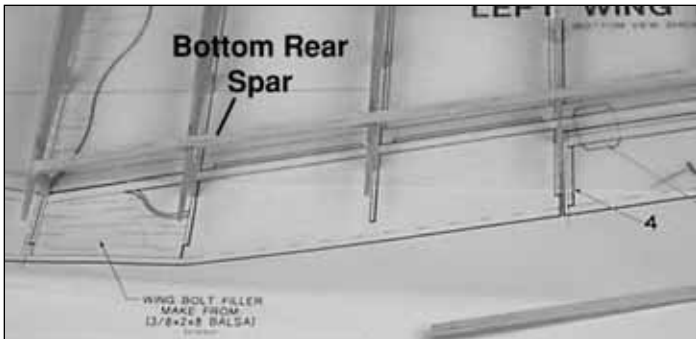

7. Glue the $\frac{1}{8}$ " x $\frac{1}{4}$ " x 36" balsa **bottom rear spar** in place butting it against R1. Remember we are building the wing upside-down so the bottom spar is on the top now. **Note:** It is necessary to bevel the root end of the spar so it will fit well against R1.

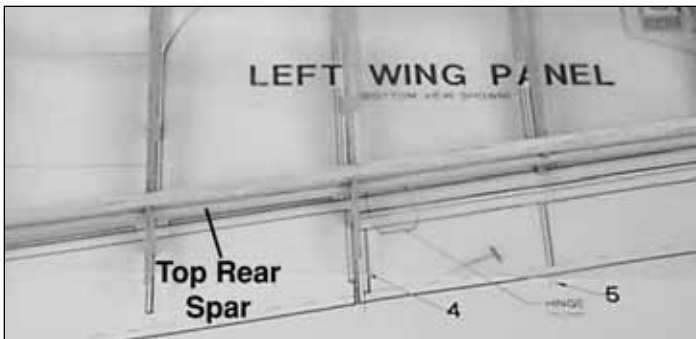

8. Pull the $\frac{1}{8}$ " x $\frac{1}{4}$ " x 36" balsa **top rear spar** up into the notches in the ribs and glue in place. Trim the ends of the rear spars off at the wing tip.



9. Make marks on the ribs $\frac{3}{8}$ " forward of the rear spar.



10. Glue a piece of $\frac{1}{16}$ " x 3" x 36" balsa sheet on the TE of the wing, aligning the LE of the sheeting with the marks you made in step 9.

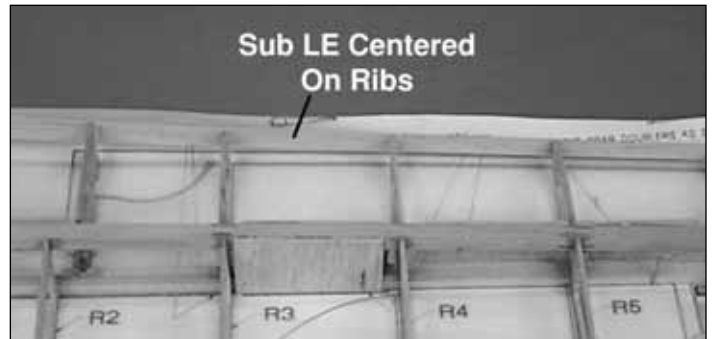

11. Glue the $\frac{3}{32}$ " x $\frac{5}{8}$ " x 30" **sub LE** on the LE of the ribs, centering it vertically and leaving the excess at the root of the wing.

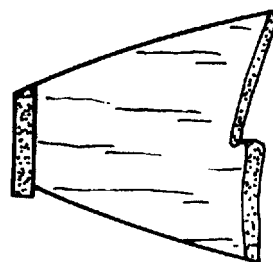

12. Use a razor plane and/or a sanding block, shape the sub LE so it aligns with the tops of the ribs and the shape of the airfoil.



13. Glue a $\frac{1}{16}$ " x 4" x 32" balsa sheet to the forward half of the main spar. **Note:** Make sure the sheeting hangs over the tip rib and the center of the wing slightly.



14. Carefully lift the sheeting away from the ribs, then apply a bead of medium or thick CA to the top of each rib and the sub LE. Working quickly, pull the sheeting forward as you press it down to the ribs and the sub LE. Use weights to hold the sheeting to the ribs and sub LE until the CA cures. **Note:** It may be necessary to place weights on the TE of the wing so that the TE of the wing stays down on the jig tabs.

Sheet the Center Section

1. From a 1/16" x 3" x 36" balsa sheet, cut three 10-1/2" long sheets. From another 1/16" x 3" x 36" sheet, cut one more 10-1/2" long sheet. Save the remaining 25-1/2" for step #3.

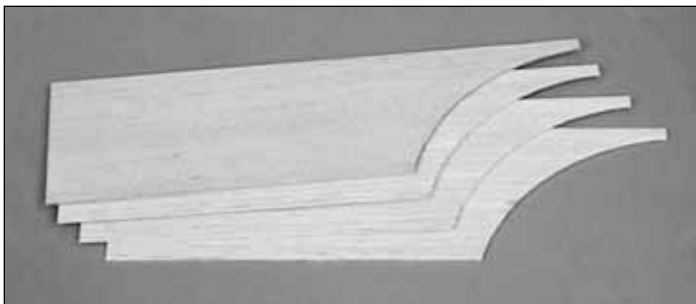

2. Cut a curve on the end of one of the sheets, using the plan as a guide. The curve does not have to be an exact match. Use that one as a template to mark and cut the three other sheets. These are the **forward center sheets**.

3. From a leftover piece of 1/16" x 3" x 25-1/2" balsa sheet, cut three 7" long sheets. From a 1/16" x 3" x 36" balsa sheet, cut five 7" long sheets. These eight 7" pieces are used for the rest of the center sheeting.



4. Fit and glue one of the four **forward center sheets** (from step 2) in place on the wing.



5. Glue the 7" balsa **middle center sheet** in place.



6. Using a 7" balsa sheet, fit and glue the **rear center sheet** in place.

Servo Mount



1. Glue the die-cut 1/8" ply **aileron servo tray (6A)** to the spar and rib with medium CA.

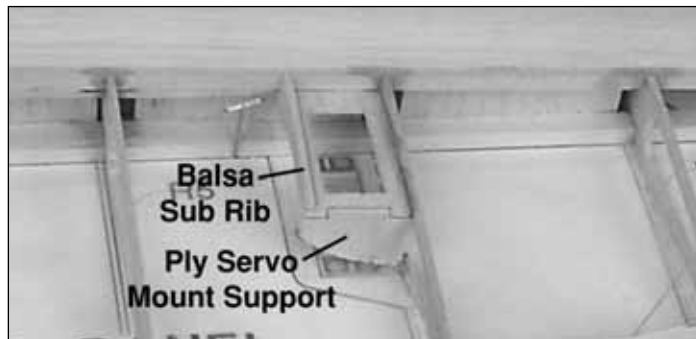

2. Glue the die-cut 1/8" ply **servo mount support (6B)** in place.

3. Glue the die-cut 3/32" **balsa sub rib (6C)** in place.



4. Glue a piece of 1/16" balsa to the servo mount support, aligning it with the top of the sub rib and the top of R6 as shown in the photo.

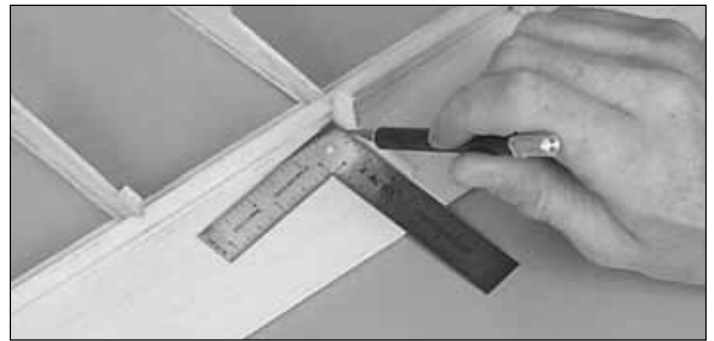

5. Using leftover 1/16" balsa, sheet over the servo tray area. **Note:** You will cut the opening for the servo after the wing is unpinned from your building board.

9. Cut the TE sheeting along the outside edge of R4 from the aft edge of the spar to the aft edge of the sheeting. Trim the TE sheeting flush with the aft spar from R4 to the wing tip. **Note:** Save this piece of sheeting for the aileron.

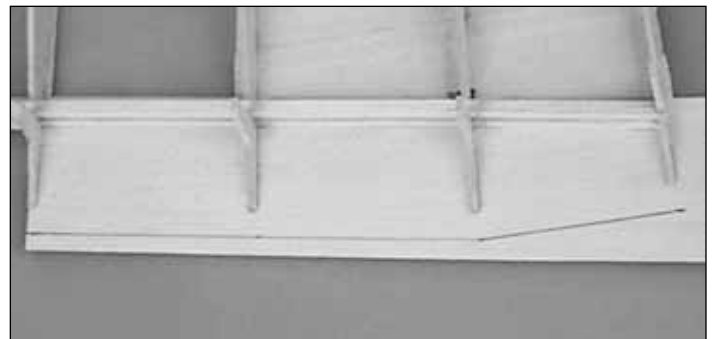

6. From a 1/16" x 1/4" x 36" balsa stick, cut and glue **cap strips** to all of the exposed ribs. **Hint:** For easier positioning of the cap strips, first mark the location of each rib on the LE and TE sheeting.



7. Remove the T-pins, then take the wing off your building board.

10. Draw a line 1/2" behind the TE of R2 - R4. Draw another line 1/2" behind R1 and R2. Trim the TE sheeting on the lines you just made.

8. Trim the LE sheeting flush with the front of the sub LE.

11. Trim the center sheeting and TE sheeting flush with R1.

12. Use a razor saw to accurately cut the spars, sub LE, LE sheeting and TE sheeting flush with R10.

☐☐ 13. From the 3/8" x 2" x 8" balsa block, fit and glue the **wing bolt filler** between the TE of R1 and R2. Sand the wing bolt filler to the contour of ribs R1 and R2.



☐☐ 18. Using a razor saw and a hobby knife, trim the spacer tabs off of R1, R2 and R2A.



☐☐ 14. Cut the opening for the servo in the sheeting using the servo tray as a guide.



☐☐ 19. Sand the bottom TE sheeting as shown in the sketch.

If this is your first time through, go back to the start of **Build the Wing Panels** on page 12 and build the right wing half.



☐☐ 15. Fit your aileron servo in place and trim the sheeting from around the rubber grommets on your servo. **Note:** You need approximately 1/16" of clearance between the servo and the sheeting.

Join the Wing Panels

☐☐ 16. Trim the jig tabs off the ribs and sand the ribs smooth. Be careful not to sand into the ribs, changing the shape of the airfoil.

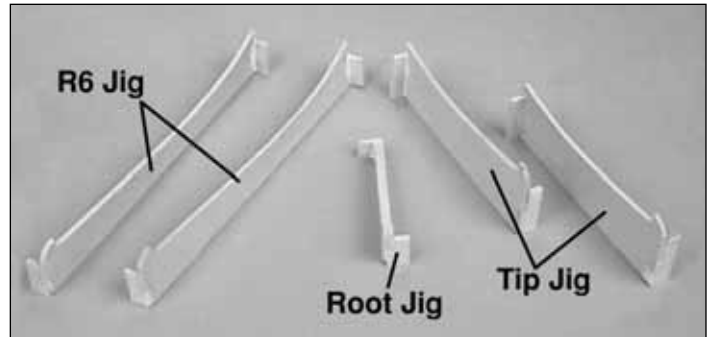

☐ 1. From the die-cut 1/8" ply pieces, make the five **wing jigs** as shown in the photo above.

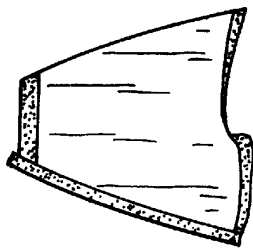

☐☐ 17. Use a razor plane and/or a sanding block to shape the sub LE so it aligns with the tops of the ribs and the shape of the airfoil.

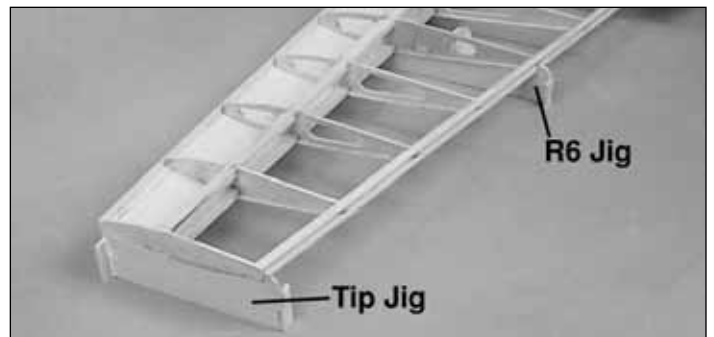

☐ 2. **Without using any glue**, test join the wing panels on the five wing jigs as shown in the photos for steps 2 and 3. Make sure the ends of the spars and TE's join without any gaps.

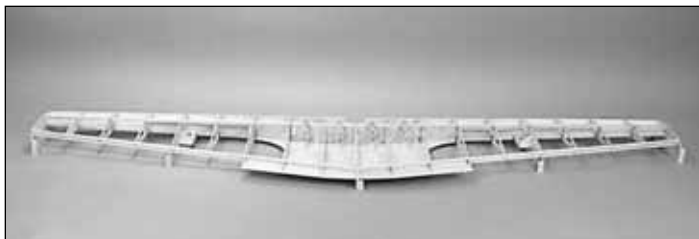
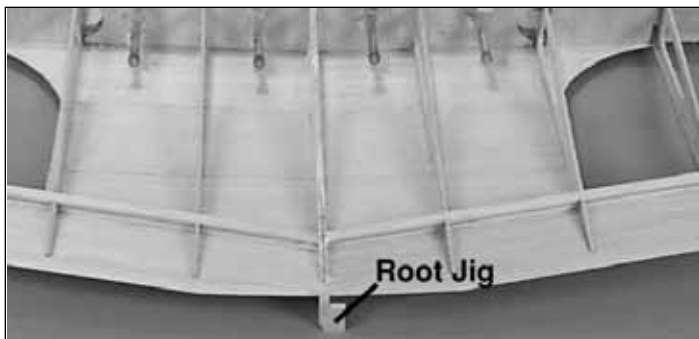

❑ 3. Place a Great Planes Plan Protector under the center of the wing to catch excess epoxy. When satisfied with the fit, glue the die-cut 1/16" ply **dihedral braces (DB)** to the spars with 30-minute epoxy by spreading a film of epoxy on *both* the spars *and* the dihedral braces and using C-clamps to hold them in place. Once the C-clamps are tightened, wipe away excess epoxy before it cures. Place weights on top of your wing to hold it in place.

❑ 4. Glue the TE's together with thin CA. Do not disturb the wing until the epoxy cures.

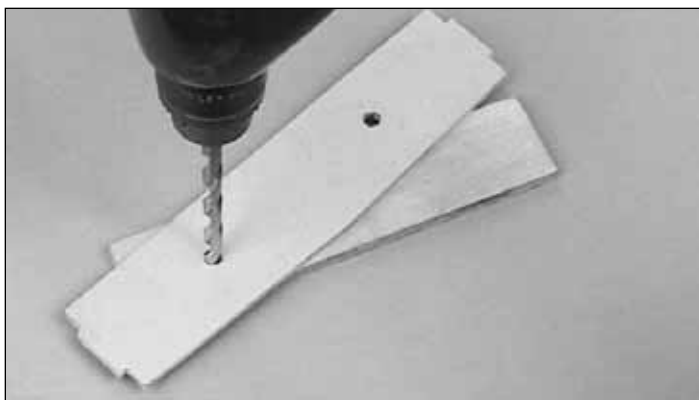

❑ 5. Drill two 1/4" holes in the each of the two die-cut 1/8" ply **dowel plates (D)**.

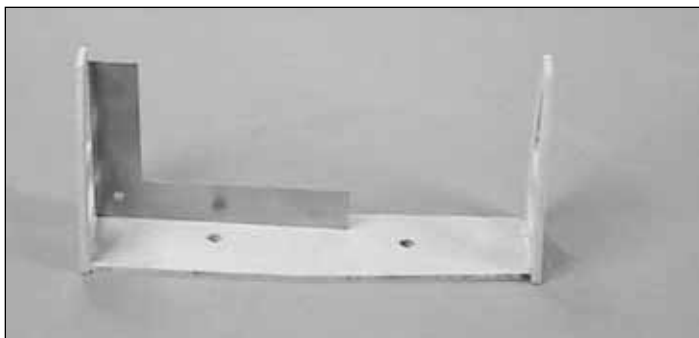

❑ 6. Glue the die-cut 1/8" ply **sub ribs (2D)** to one of the dowel plates, using a square to assure alignment.

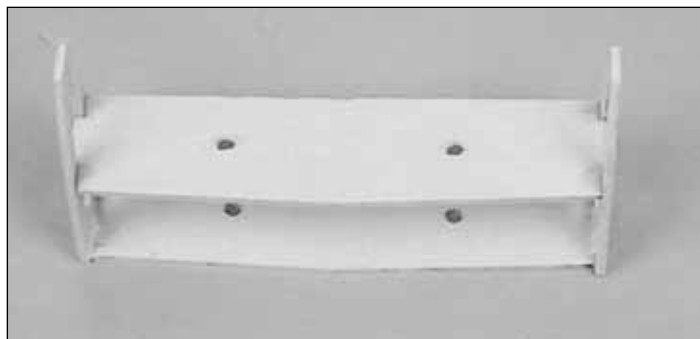

❑ 7. Glue the other dowel plate into the slots in the sub ribs. **Note:** Make sure the "V"s on the dowel plates are both on the same side.

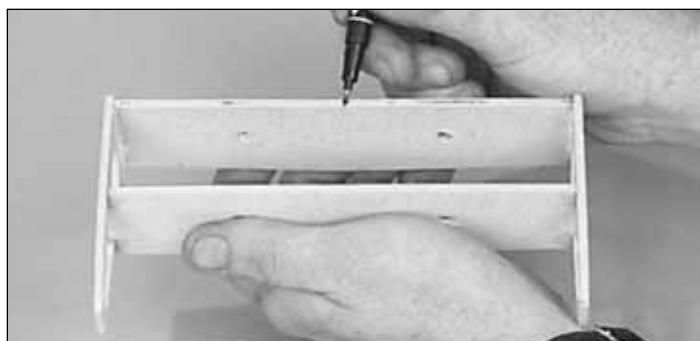

❑ 8. Measure and make an accurate reference mark at the center point on the top of both dowel plates.



❑ 9. Use 6-minute Great Planes Pro Epoxy to glue the dowel plate to the dihedral brace, aligning the center mark you made with the spar joint, and clamp it in place. **Note: Do not allow epoxy to get in the dowel holes on the dowel plate.**

❑ 10. Glue the forward dowel plate and the sub ribs to the wing sheeting with thin CA.

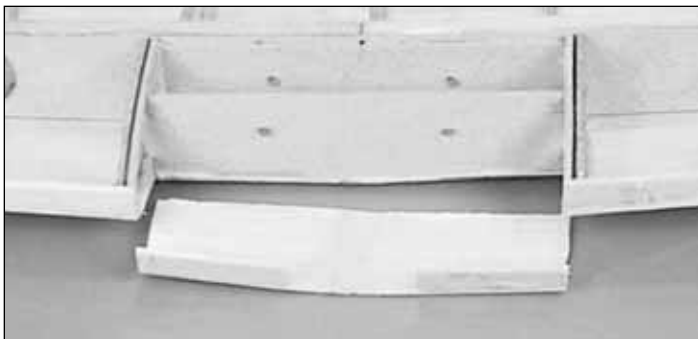

11. Trim the sub LE and the sheeting flush with the sub ribs and the dowel plate.

Sheet the Top of the Wing

Note: While sheeting the top of the wing it is not necessary to put the jigs under the whole wing. It is only necessary to put the jigs under the wing half you are sheeting.

1. Put the wing back on the building jigs for the next 6 steps.

2. Make marks on the ribs 3/8" in front of the aft spar, the same as you did on the bottom of the wing.



3. Align a 1/16" x 3" x 36" balsa TE sheet to the marks you just made, and trim the end of the sheet to the angle at the center of the wing.

4. Glue the TE sheet in place, aligning it with the center of the wing and the marks you made in step 3. **Note:** It is necessary to move the center jig over slightly so the sheeting can align with the marks you made and extend over the bottom TE sheeting.

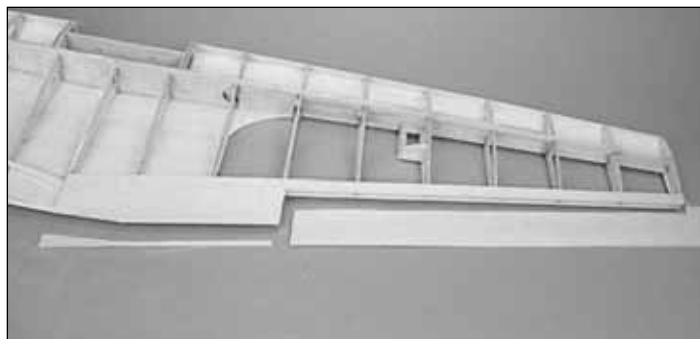

5. Lift the wing off the building board and trim the sheeting the same as you did on the bottom of the wing. Save the bigger piece for the aileron.

6. Repeat steps 2-5 for the other wing half.



7. Put the wing back on the jigs again. Glue the 1/16" x 4" x 32" balsa LE sheeting to the spar, aligning the TE of the sheeting to the center of the spar.

8. Glue the sheeting to the ribs and sub LE as you did on the bottom of the wing.



9. Trim the sheeting flush with R10, the sub LE, the ply sub rib and the dowel plate.

10 Repeat steps 7-9 to add the LE sheeting to the other wing half.



☐ 11. Sheet the center of the wing with the remaining six pieces of center sheeting.

☐ 12. Use the two remaining 1/16" x 1/4" x 36" balsa sticks to cap strip all the exposed ribs.

☐ 13. From the 3/16" x 1/4" x 30" balsa stick cut eight 3" long hinge blocks.

Shape the 3/16" x 1/4" x 3" stick so it will fit between the rear spars.

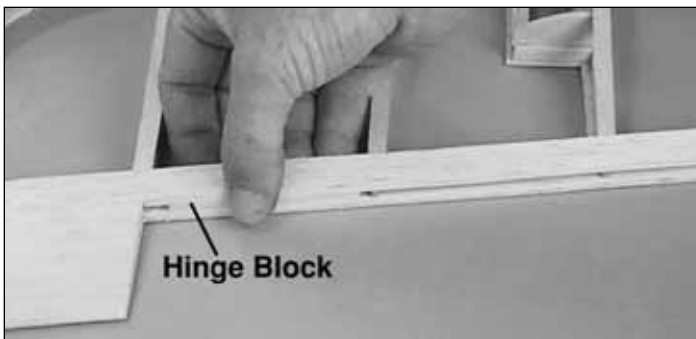
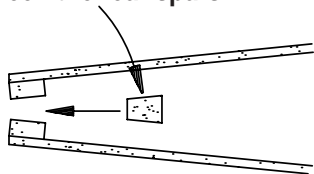

☐ 14. Test fit one of the hinge blocks between the TE spars and between R4 and R5. When satisfied with the fit glue in place with thin CA.

☐ 15. Do the same between R6 and R7, between R7 and R8, and between R9 and R10 on both wing halves.

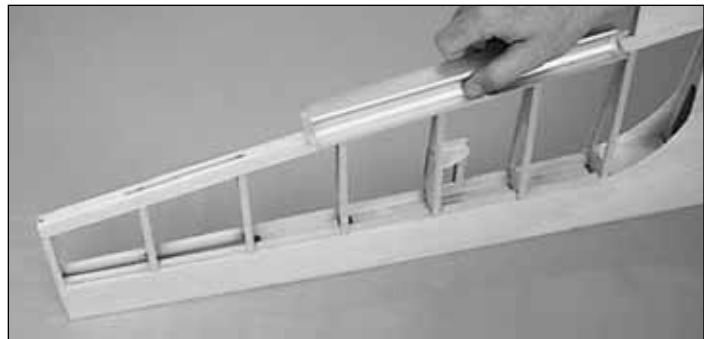

☐ 16. Sand the TE of the wing square.

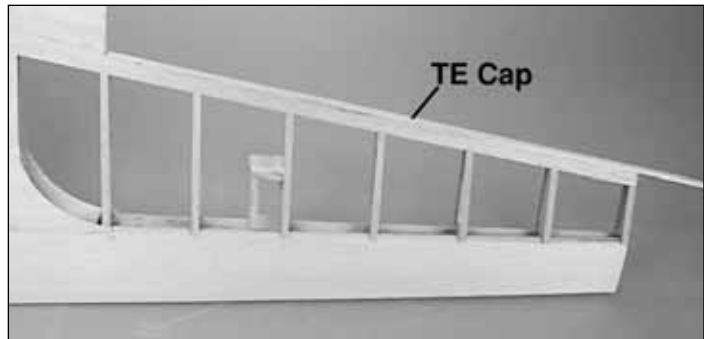

☐ 17. Glue the two 3/32" x 9/16" x 24" balsa **TE caps** in place.



☐ 18. Cut the ends of the TE caps off flush with the sides of the wing tip.



☐ 19. Sand the TE caps flush with the TE sheeting.

☐ 20. Glue the 5/16" x 5/8" x 30" LE in place. Sand the root of the LE flush with the sub ribs. Sand the tips flush with R10.

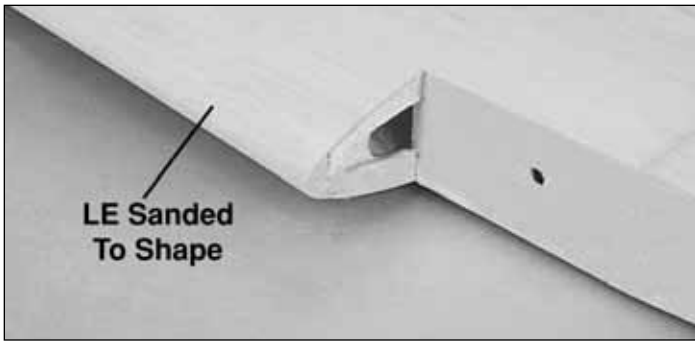

21. Sand the LE to the airfoil shape shown on the plans.

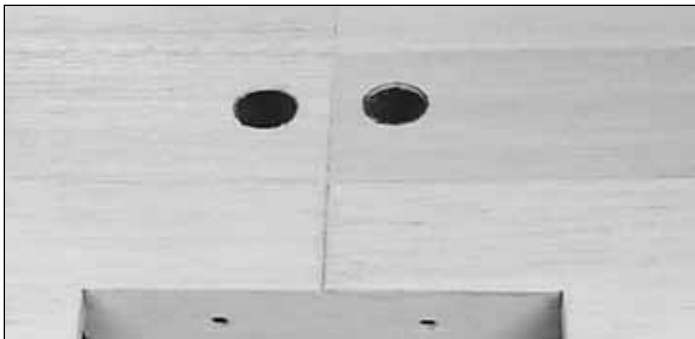

22. Using the plans as a reference, cut the servo wire holes in the top of the wing.

23. Cut two 6-1/4" long pieces from the 1/4" x 2" x 24" balsa sheet for the **wing tip caps**. Cut two more 2-1/4" long pieces for the **root rib caps**.

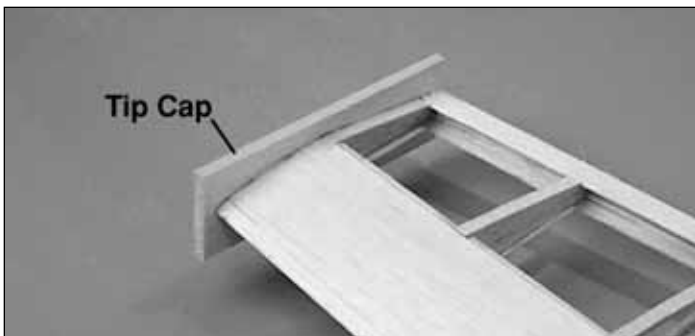
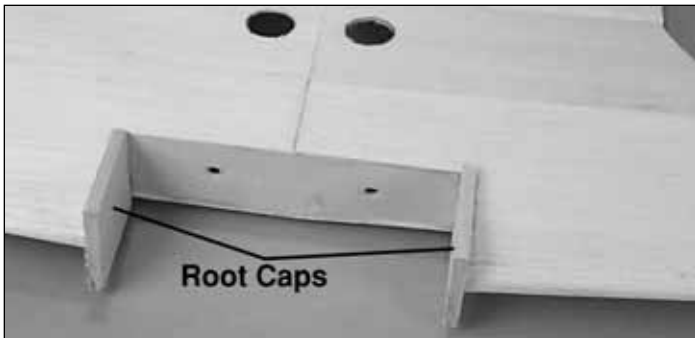

24. Glue the 6-1/4" long tip caps to the wing tips. Glue the 2-1/4" long root caps to the root ribs.

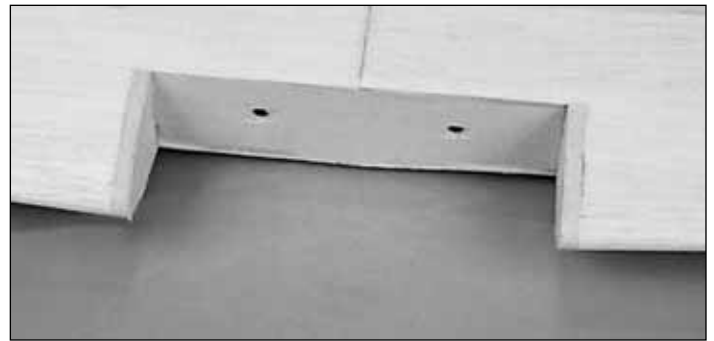

25. Sand the root caps and tip caps to match the shape of the wing.

26. Slightly round one end of both of the 1/4" x 2-1/2" **wing dowels**.

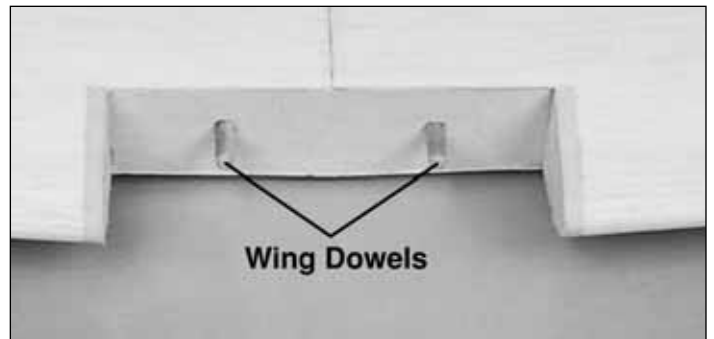

27. Test fit the dowels into the wing. When satisfied with the fit, use 6-minute epoxy to glue the dowels in place.

Build the Ailerons

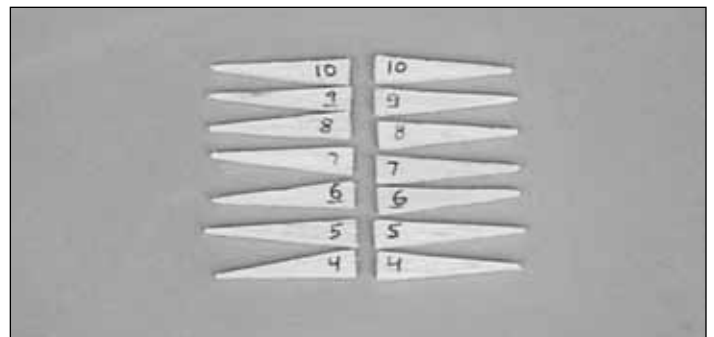

1. Remove the fourteen die-cut 3/32" balsa **aileron ribs**, labeling each of them as you do so. Cut 2" off the end of a 3/8" x 3/8" x 24" balsa stick to be used for the control horn doubler in the aileron.

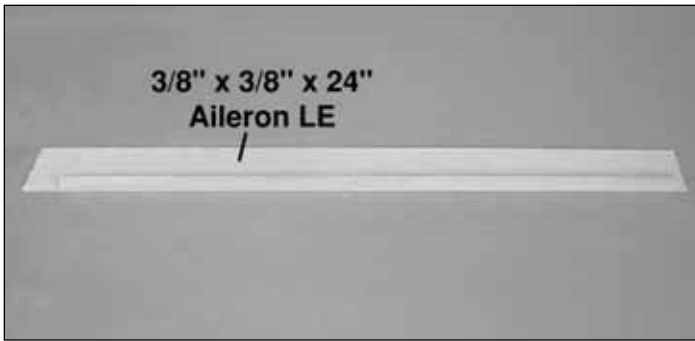

2. Find one of the 1/16" balsa sheets that you have saved from the TE sheeting of the wing, and trim it to 2" wide. Glue the 3/8" x 3/8" x 24" balsa **aileron LE** to the sheet, aligning it along one of the trued edges of the sheet.

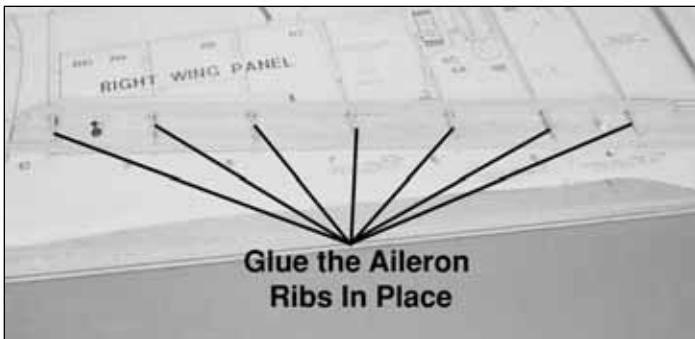

3. Cover the aileron portion of the plan with a Great Planes Plan Protector. Pin the aileron sheet with Aileron LE in place on the plan. Use thin CA to glue the seven die-cut 3/32" balsa aileron ribs perpendicular to the bottom sheet and tight against the 3/8" aileron LE.

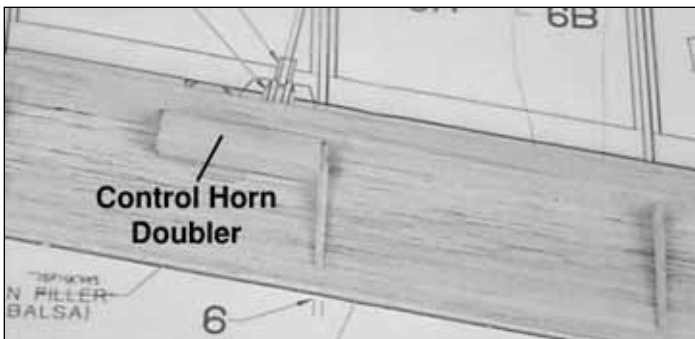

4. Glue the control horn doubler in position against aileron rib #6.

5. Remove the aileron from the building board, trim the sheeting flush with ribs #4 and #10.



6. Sand the aileron LE and the TE of the sheeting with your sanding bar as shown in the sketch.



7. Using another 1/16" balsa sheet that you saved from the TE sheeting, glue the bottom aileron sheeting in place, aligning it with the TE of the top aileron sheet on the sanded aileron.

8. Trim the bottom aileron sheeting flush all the way around the aileron.

9. Glue a leftover piece of 1/16" balsa **aileron cap**, to the root end of the aileron.

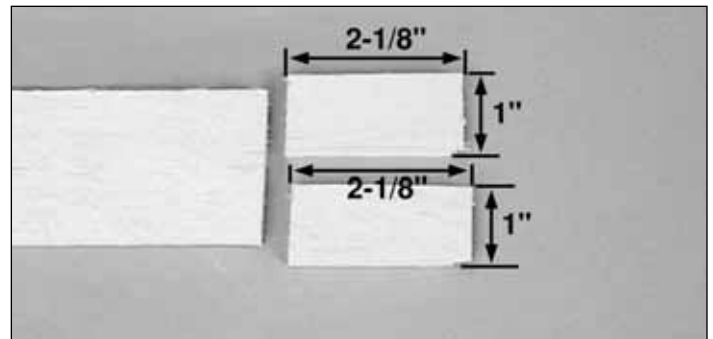

10. Cut 2-1/8" from the 1/4" x 2" x 7" balsa stick you saved from the wing building section. Cut the 2-1/8" piece in half lengthwise making two **aileron caps**. Glue the aileron cap onto the aileron tip end, save the other piece for the other aileron.

11. Sand the aileron caps flush.

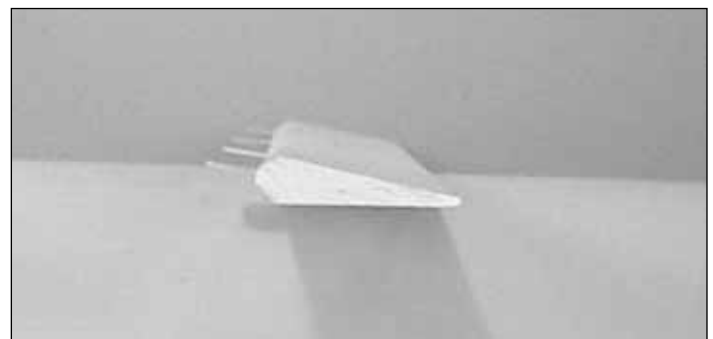

12. Bevel and hinge the aileron the same as did with the elevator and rudder. Cut the hinge slots in the wing TE to match the hinge locations on the aileron.

13. Go back to step #2 and build the other aileron.

BUILD THE FUSELAGE

Assemble the Fuselage Formers & Sides

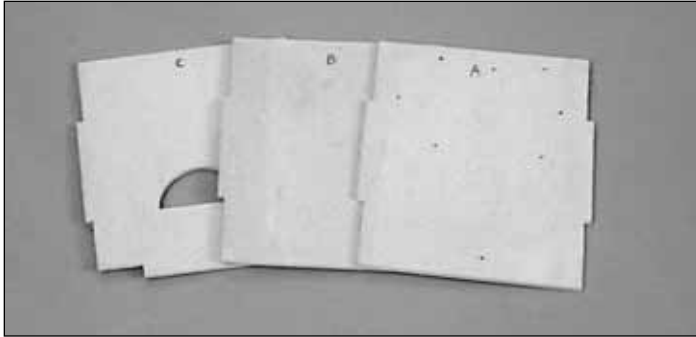

- ❑ 1. Use 30-minute epoxy to glue the **firewall formers A, B and C** together. Make sure the **embossed label on A** is facing **UP** and the top edge and tabs on all three formers are aligned. Wipe away excess epoxy before it cures. From now on this assembly will be referred to as the **firewall**. **Note:** If the formers are warped, simply clamping them together may not “cancel out” the warps. It is best to clamp the formers to a table or a flat board until the epoxy cures.

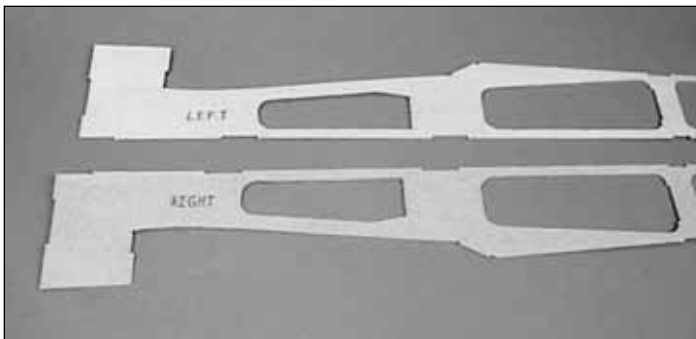

- ❑ 2. Lay the two **fuselage sides (part #1)** next to each other **as shown in the photo** and label the insides as the **LEFT** and **RIGHT**. It is important that you lay the fuselage sides in a mirrored position to insure that you build a right and a left side.



- ❑ 3. Fit **former 7 (part #7)** in place on the right fuse side. Butt the **fuse doubler (part #2)** up against former 7 and mark around the perimeter of the fuse doubler.

- ❑ 4. Use medium CA to **accurately** glue the **fuse doubler (part #2)** to the **inside** of the **right** fuselage side. **Do not** glue former 7 in place at this time.

- ❑ 5. Glue the left fuselage doubler to the inside of the left fuselage side in the same manner.

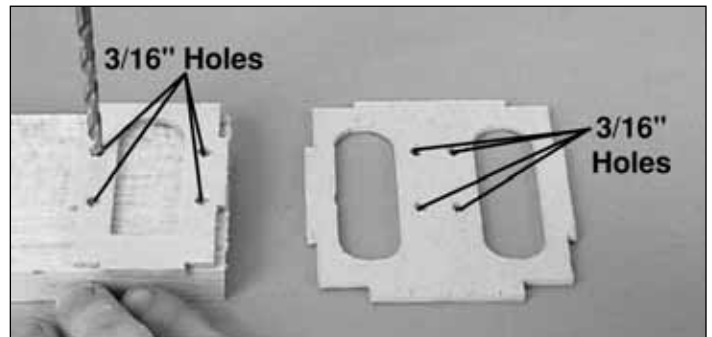

- ❑ 6. Drill a 3/16" hole through each of the punch marks in **formers 9 and 10**.

Hint: Place the formers on a leftover piece of wood and press down as you drill the hole so the former does not split when the drill goes through.

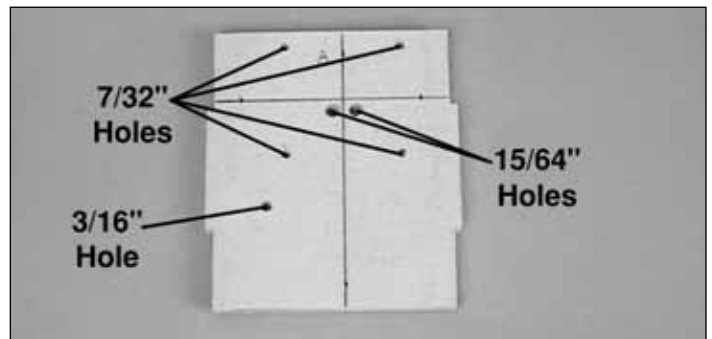

- ❑ 7. Draw center lines connecting the outer punch marks on the **firewall**. Drill 7/32" holes for the engine mount bolts at the four engine mount punch marks. Drill a 3/16" hole for the throttle pushrod at the punch mark. Drill two 15/64" holes for the fuel tubes.

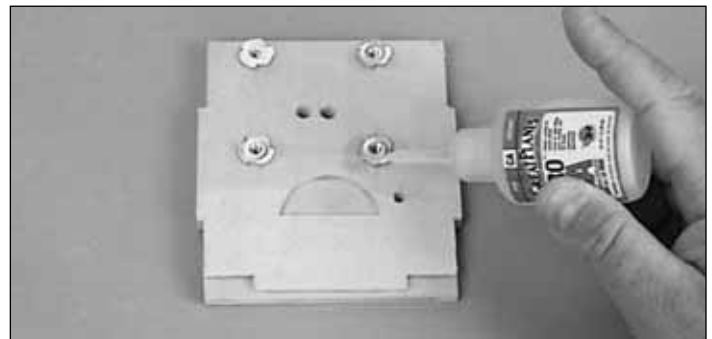

- ❑ 8. Press four supplied **8-32 blind nuts** into the holes on the back of the firewall. Gently tap the blind nuts with a hammer to fully seat them into the firewall, then add a few drops of thin CA around the blind nuts to secure them.

- ❑ 9. File off the 1/64" of the blind nuts that extend above the top of the firewall.

Assemble the Fuselage

The fuse plans were reduced to 75% so that they are easier to use as a reference while building. The interlocking construction of this kit allows you to quickly assemble the fuselage upside-down on a line drawn on your work surface while being able to reference the plans because they are not covered up with the parts you are assembling. You will be fitting most of the die-cut fuselage parts together before applying glue. **Do not use any glue until instructed to do so.**

- 1. Draw a straight line on your work surface 45" long. Cover this line with Great Planes Plan Protector.

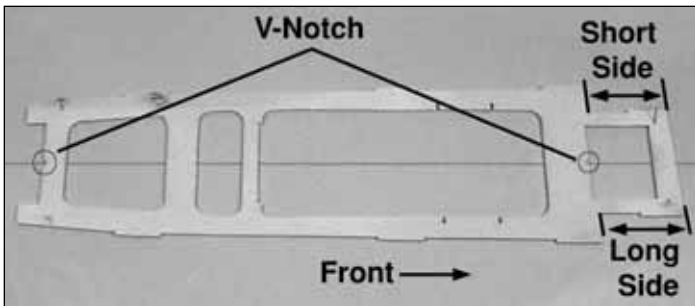

- 2. Pin the die-cut 1/8" ply **forward fuse top (part #3)** in position over your reference line, aligning the V-notches with the line. Make sure the front of the fuse is the same as shown in the photo.

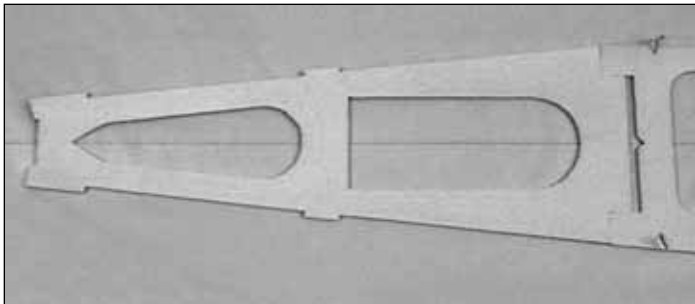

- 3. Fit the die-cut 1/8" ply **aft fuse top (part #12)** in place and align it with the reference line. When satisfied with the alignment, glue it to the fuse front with thin CA.

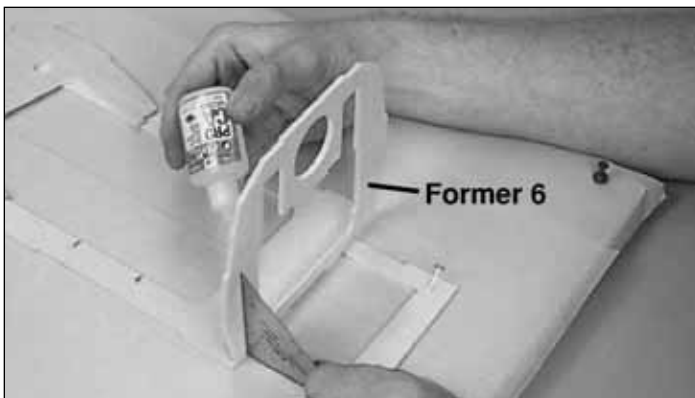

- 4. Keeping the die-cut 1/8" ply **former 6 (part #6)** perpendicular to the fuse top, glue it in place with thin CA.

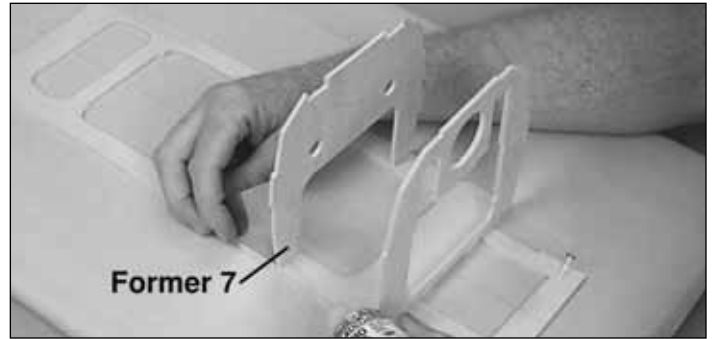

- 5. Glue **former 7 (part #7)** in place the same way.

Note: These next three steps should be completed together and assembled quickly.



- 6. Wet the outside of both fuse sides from the middle of the wing saddle forward.

- 7. Glue the fuse sides to the fuse top from former 6 to the middle of the wing saddle with thin CA and accelerator.

- 8 Hold the fuse sides in place with tape, clamps or your hands and glue to the formers with medium CA or epoxy. **Hint:** Using tape to hold the fuse sides in position makes it possible to leave the tape in place on the fuse until the landing gear former and bottom corner pieces are put in place.

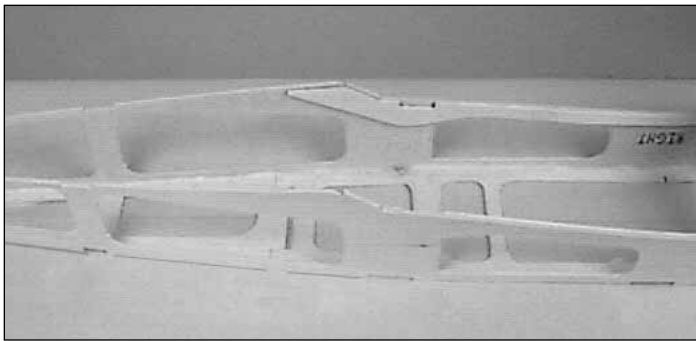

❑ 9. Glue the rest of the fuse sides to the fuse top.

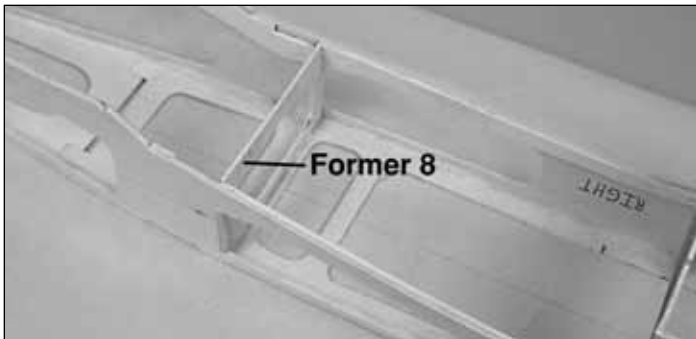

❑ 10. Glue **former 8 (part #8)** in place.

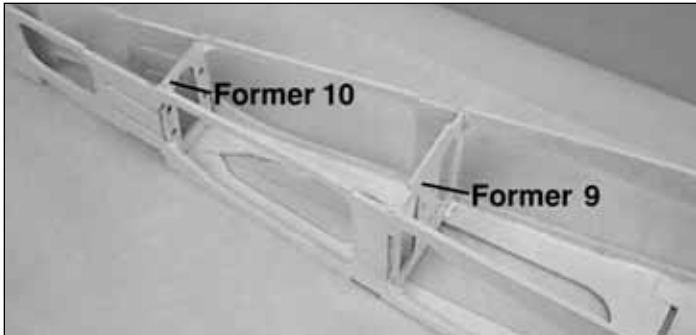

❑ 11. Glue **former 9 (part #9)** and **former 10 (part #10)** in place.

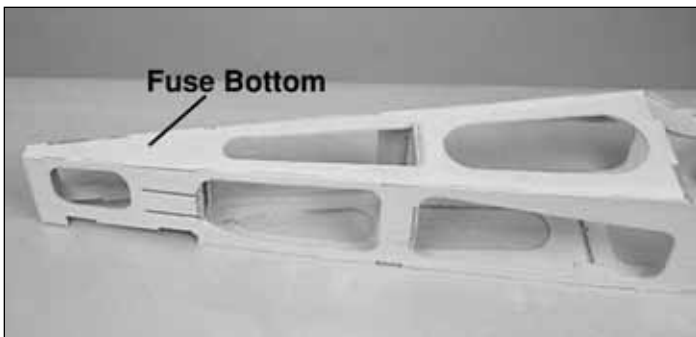

❑ 12. Glue the **fuse bottom (part #4)** in place. **Note:** Former 9 extends through the fuse bottom. This will be used as a guide for the bottom stringers later in the manual.

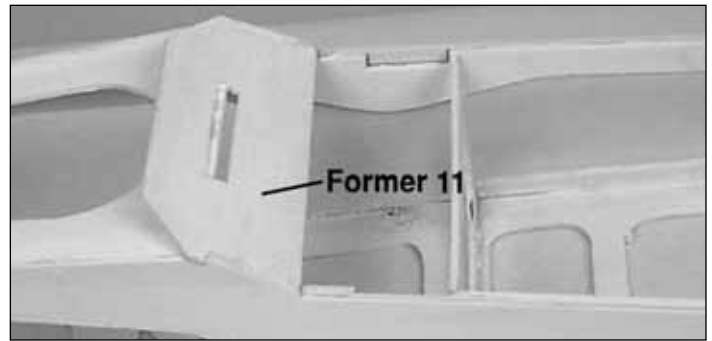

❑ 13. Glue **former 11 (part #11)** in place.

❑ 14. Sand the 1/4" x 1-1/4" x 5-1/2" birch ply **wing bolt block** to fit precisely in the slots in the fuse doublers. **Note:** It is very important that the fit of the wing bolt block be precise.

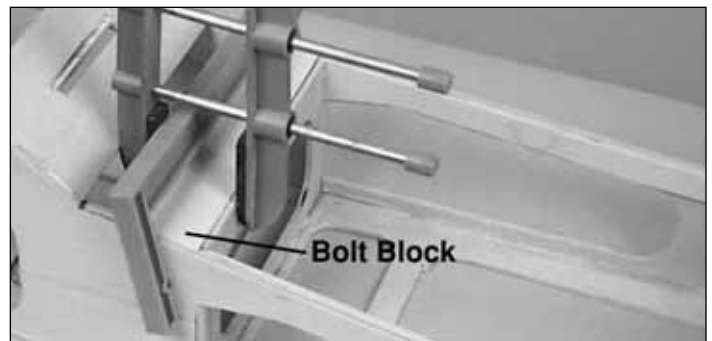

❑ 15. When satisfied with the fit of the wing bolt block, glue it in place with 30-minute epoxy.

Mount the Wing to the Fuselage

❑ 1. Sand the entire wing saddle area lightly until the fuse side doublers and fuse sides are flush.

❑ 2. Test fit the wing on the fuse. If the wing is slightly too large (front to rear) to fit into the saddle, sand the TE of the wing slightly until it fits.

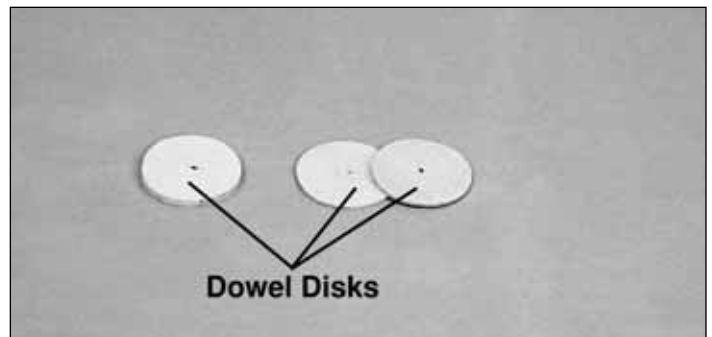

❑ 3. Laminate two pairs of the die-cut 1/16" wing dowel disks together with 6-minute epoxy. Drill 1/4" holes through the punch marks at the center of each of the laminated disks.

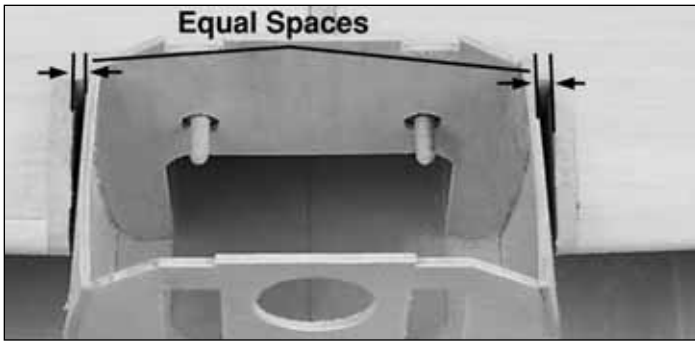

❑ 4. Center the wing side to side, leaving equal space between the fuselage sides and the wing at the leading edge.

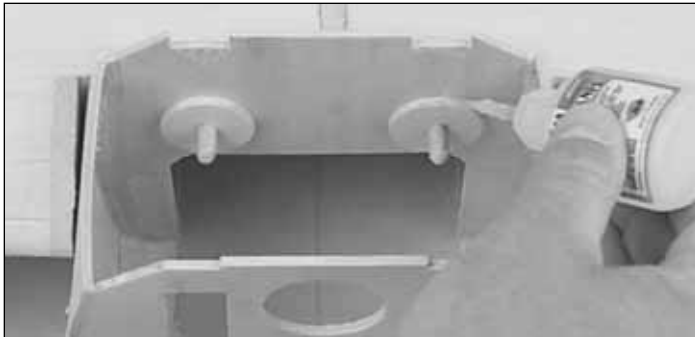

❑ 5. Making sure to keep the wing centered and in the saddle, tack glue the **dowel disks (part #37)** in place with thin CA. **Note: DO NOT GLUE THE DOWEL DISKS TO THE WING DOWELS.**

❑ 6. Remove the wing and permanently glue the dowel disks in place with thin CA.

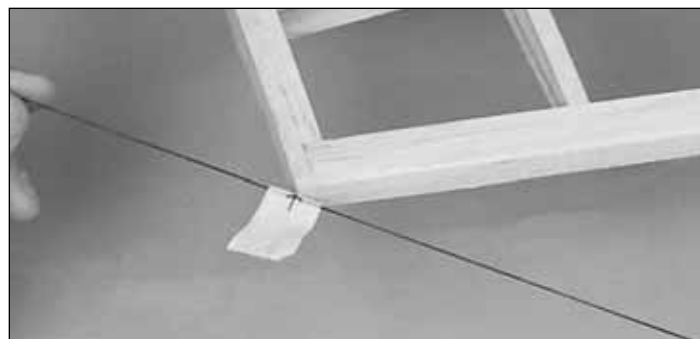
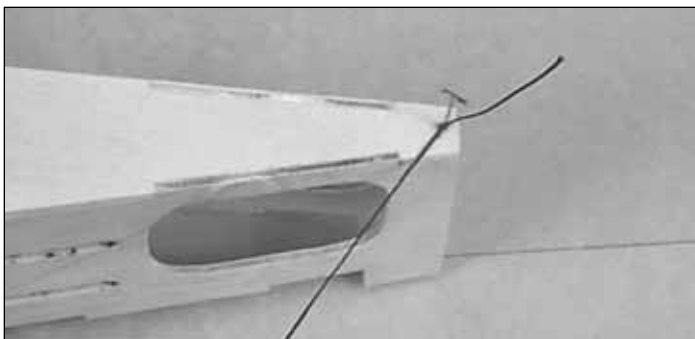

❑ 7. Stick a T-pin through the center of the aft end of the fuselage bottom. Tie a string to the T-pin. Pull the string to the TE of the wing tip and put a piece of masking tape on the string at the wing tip. Mark an arrow on the tape, then slide the tape on the string so the arrow aligns with the

wing tip. Swing the string over to the other tip and see if it aligns with the same point. If necessary shift the wing and mark the location of the tip by adjusting the position of the tape on the string. Do this until the arrow on the string aligns with both tips.

❑ 9. Make two alignment marks on the TE of the wing where it meets the fuselage. **Note:** You will build the belly pan onto the wing before the wing gets mounted to the fuselage, so it is important the wing stay straight in the fuselage for the next steps until the wing is bolted to the fuselage.



❑ 10. Cover the area of the belly pan with a Great Planes Plan Protector or waxed paper. Pin the **aft belly pan former (part #22)** to the fuselage.

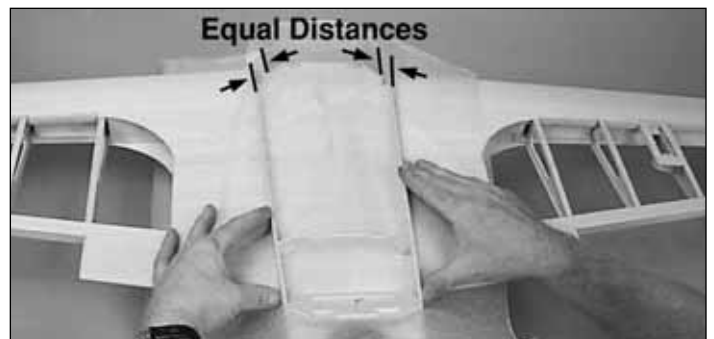

❑ 11. Fit the **belly pan sides (part #18)** and **middle belly pan former (part #20)** in place, holding the front of the belly pan sides at equal distances from the fuselage sides. When satisfied with the fit, glue the sides to both formers.



❑ 12. Glue the die-cut 1/8" ply **forward belly pan former (part #19)** to the belly pan sides. The sides will need to be bent inward to fit the former, be sure to keep the former centered on the fuselage sides.

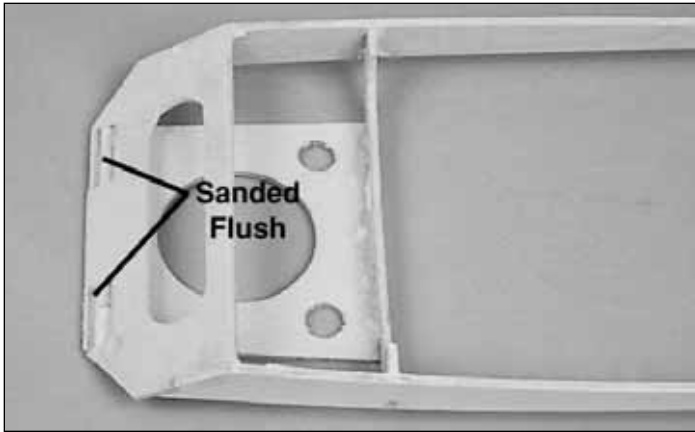

13. Remove the belly pan from the wing and glue the die-cut 1/8" ply **belly pan plate (part #23)** in place, making sure it fits all the way into the pockets. Sand the belly pan plate flush with the aft belly pan former.

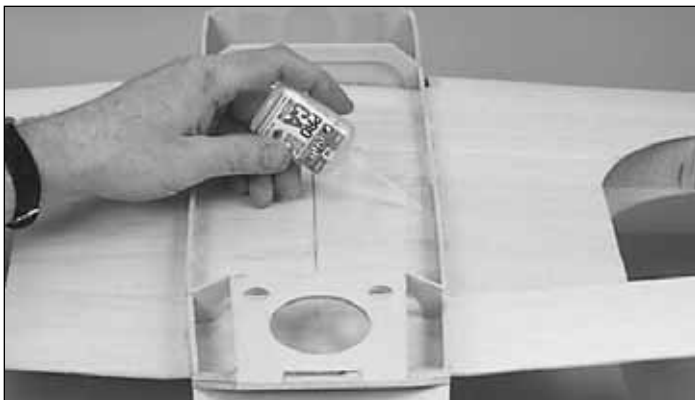

14. Double check the alignment of the wing in the fuse, then glue the belly pan to the wing with thin CA. **Note:** Do not glue the wing to the fuse.

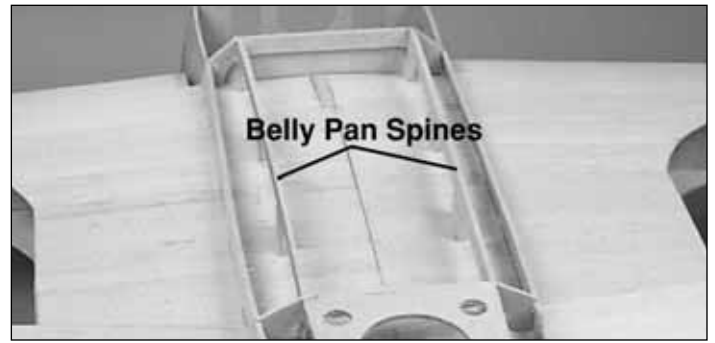

15. Glue the die-cut 1/8" ply **belly pan spines (part #24)** in place with thin CA.

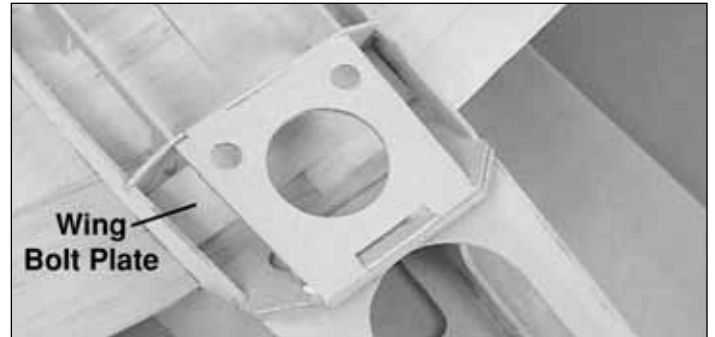

16. Glue the die-cut 1/8" ply **wing bolt plate (part #21)** in place.

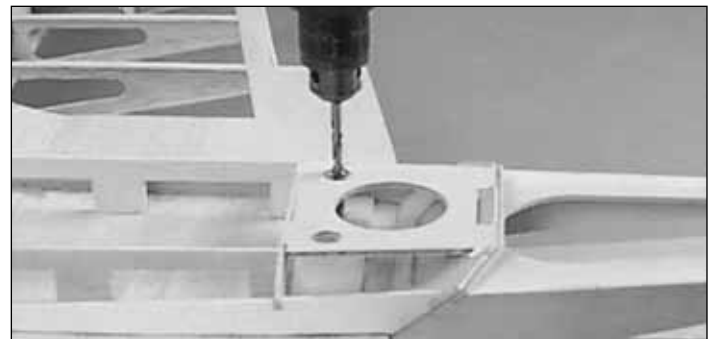

17. Holding the wing firmly in place, drill one 13/64" hole through the bolt block, keeping the drill perpendicular to the wing bolt plate and centered in the hole.

18. Remove the wing and re-drill the hole in the **wing only** to 17/64".



19. Use a 1/4-20 tap and a tap wrench to cut threads in the bolt block.

- ❑ 20. Mount the wing to the fuse with the one bolt and repeat steps 17-19 to drill and tap the other bolt hole.

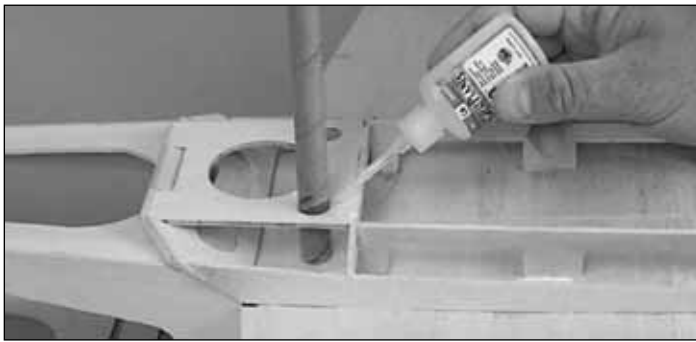

- ❑ 21. Mount the wing to the fuse with both wing bolts. Fit the **paper tube** through the belly pan plate and around the head of the right wing bolt. Sand the hole to fit, if necessary. Glue the paper tube to the belly pan former with thin CA. Do not glue around the wing bolt.



- ❑ 22. Using a razor saw cut off the paper tube flush with the belly pan.



- ❑ 23. Repeat steps 21 and 22 to mount the paper tube over the other wing bolt.

- ❑ 24. Sand the paper tubes, the aft belly pan former and former 11 flush.

- ❑ 25. Remove the wing and harden the cut threads with thin CA. Re-tap the threads after the CA fully hardens.

Finish the Bottom of the Fuse

- ❑ 1. Unpin the fuse from your work surface.
- ❑ 2. Double-check all of the glue joints. Reinforce them with medium CA as needed.
- ❑ 3. From the 1/8" x 3/4" x 24" balsa sheet cut two **fuse bottom stringers** using the template on the left side of the fuse plan as a guide.

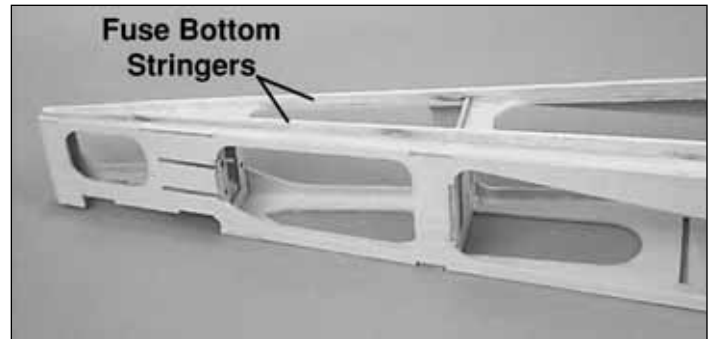

- ❑ 4. Glue the bottom stringers in place with thin CA.

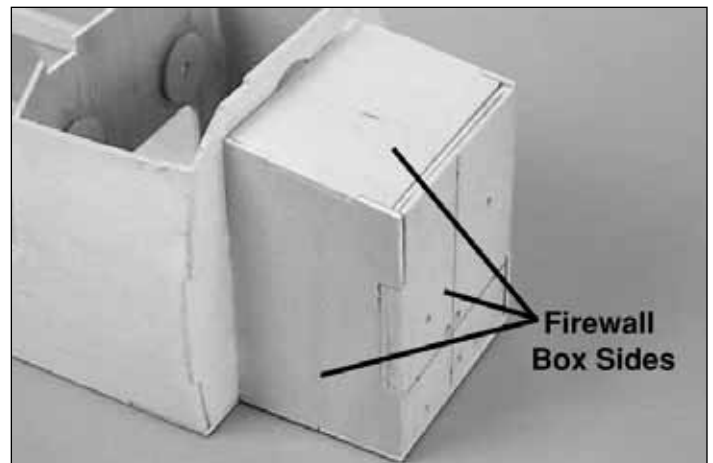

- ❑ 5. Fit the three die-cut 1/8" ply **firewall box sides** (part #'s **S, L and 14**) and the firewall in place. Glue the firewall sides and bottom to former 6 with thin CA. **Note: DO NOT GLUE THE FIREWALL IN PLACE AT THIS TIME.**



- ❑ 6. Remove the firewall from the box and glue the rest of the box together with thin CA.

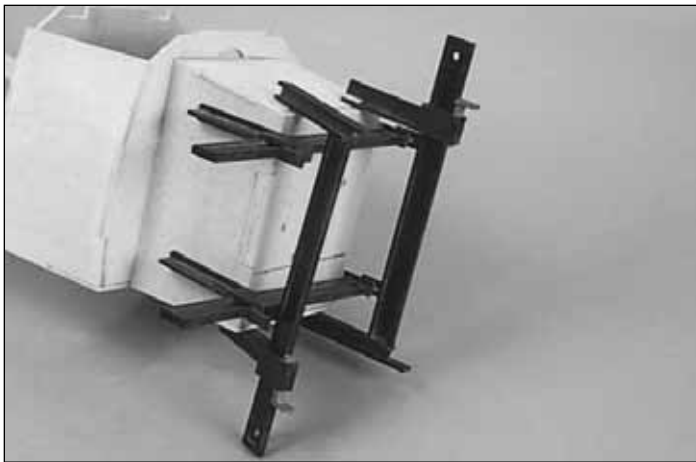

☐ 7. Using 30-minute epoxy, glue the firewall in place. Clamp the firewall to hold it in place until the epoxy cures.

☐ 8. Glue the firewall box sides to former 6 with medium CA.

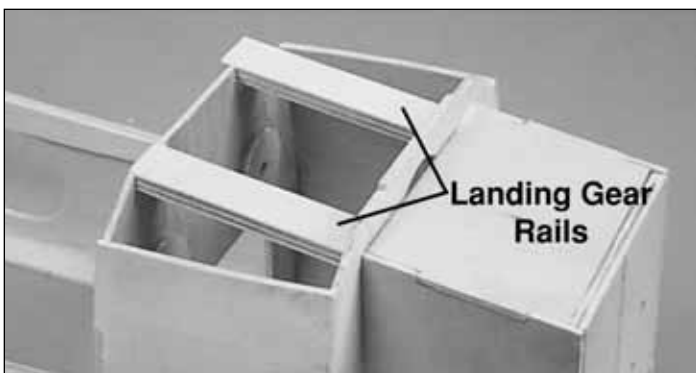

☐ 9. Fit the 1/4" ply landing gear rails in place, making sure they fit all the way into the slots in the firewall. Glue them in place with 6-minute epoxy.

☐ 10. From the 1/4" x 1/4" x 8" balsa stick, fit and glue the two **firewall gussets** in place.



☐ 11. Sand the landing gear rails flush with the back side of former 7.

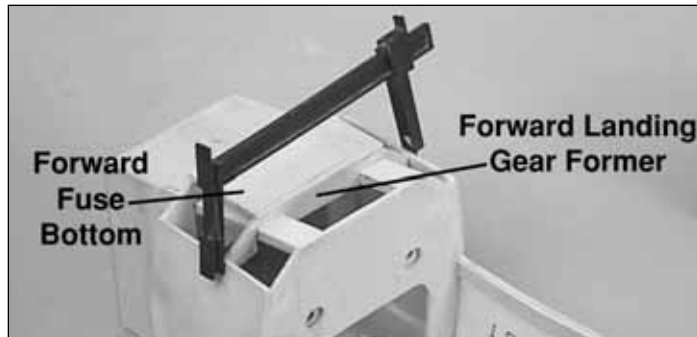

☐ 12. Fit the die-cut 1/8" ply **forward landing gear former (part #15)** and the die-cut 1/8" ply **forward fuse bottom (part #16)** in place. Clamp the fuse sides tight against the forward landing gear former and glue both pieces in place.



☐ 13. Sand the fuse side and bottom to the angle of the angled edges of former 6 and former 7.

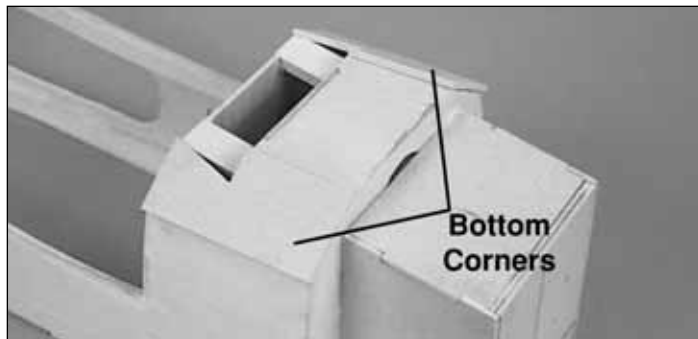

☐ 14. Glue the die-cut 1/8" ply **bottom corners (part #17)** in place.

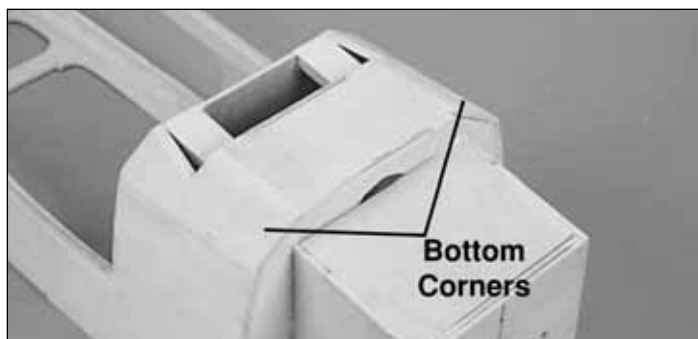

☐ 15. Sand the bottom corners to the shape of the fuse side and fuse bottom. See the cross-section of the plan for the desired shape.

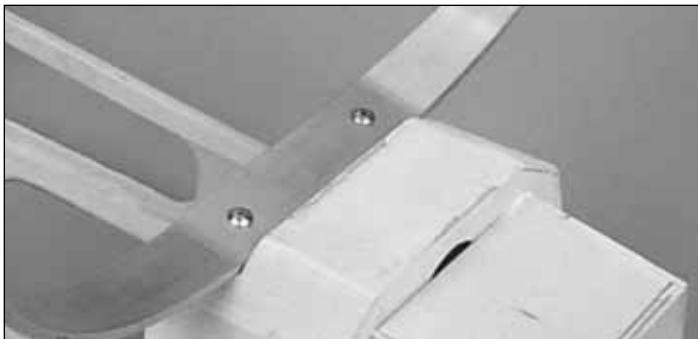

❑ 16. Center the landing gear on the fuse and drill two 1/8" holes through the landing gear rails. Mount the landing gear in place with the #8 x 5/8" truss head screws.

❑ 17. Remove the landing gear and harden the cut threads in the landing gear rails with thin CA.

❑ 18. Install the four 36" **plastic outer pushrod tubes** through the guide holes in the formers until they go through former 8 as shown on the plan. Cut the tubes so that 1" of the tubes protrude outside the slots at the aft end.

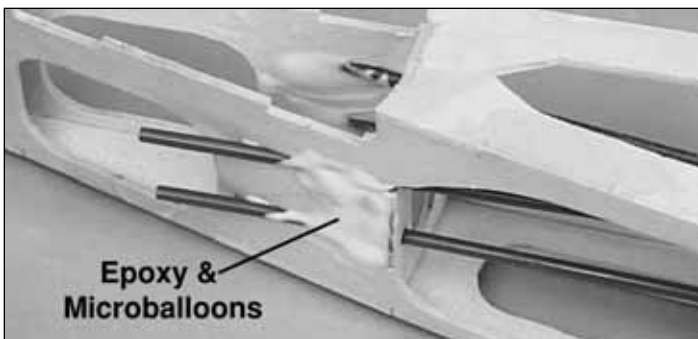

❑ 19. Glue the tubes to the slots at the aft end of the fuselage with microballoons and epoxy. Completely fill the slots with the microballoons and epoxy so they can be sanded flush later. Glue the tubes to the formers with medium CA.

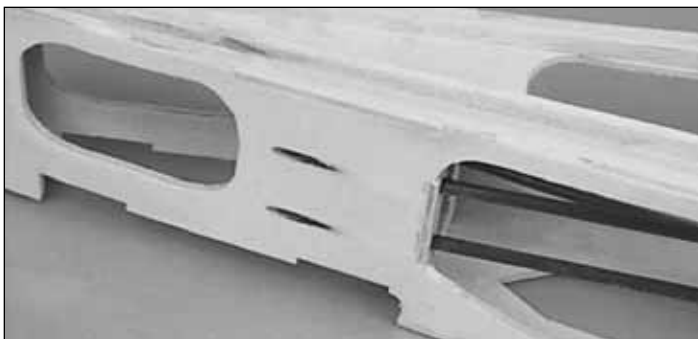

❑ 20. After the epoxy has cured, use your bar sander and 150-grit sandpaper to sand the outer pushrod tubes and epoxy filler flush with the fuselage sides.

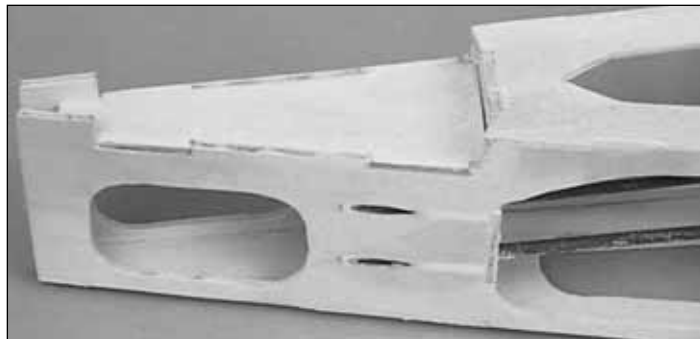

❑ 21. Glue the die-cut 1/8" ply **stab base (part #5)** in place with medium CA.

Build the Front Fuselage Deck



❑ 1. Glue the three die-cut 1/8" ply **front deck formers (part #'s 25, 26, and 27)** in place, using a 90° triangle to keep the formers perpendicular to the fuse top.



❑ 2. Glue the two 3/8" x 12" balsa triangle **transition stringers** to the front deck formers and the fuse top. Trim them flush with the front of former 6.

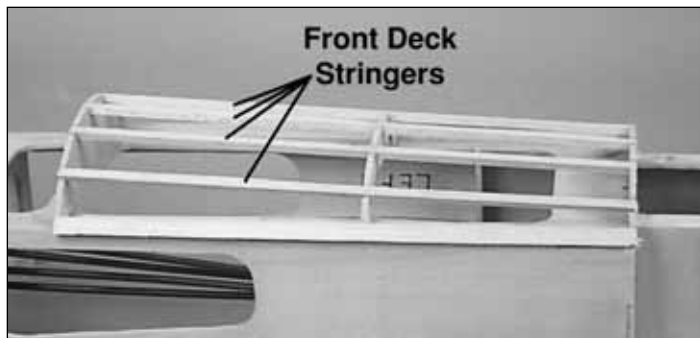

❑ 3. From the 3/16" x 3/16" x 36" balsa sticks, cut and glue the five **front deck stringers** in place.

- ❑ 4. Cut the 1/16" x 4" x 24" balsa sheet in half, making two 12" long pieces. Edge glue them together.

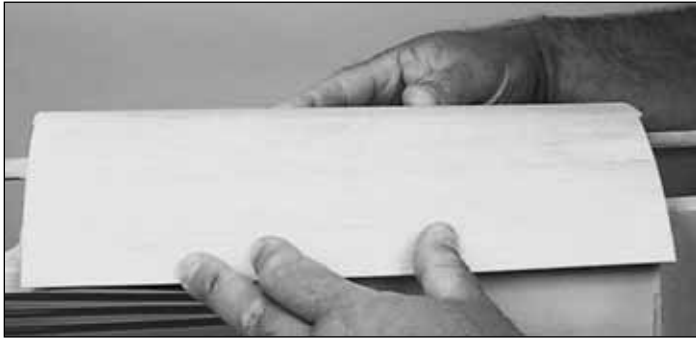

- ❑ 5. Use chalk to mark the top edge of the transition stringers. Wet the outside of the sheeting then wrap it around the stringers until you mark the sheeting with the chalk. Trim the sheeting on the outside of the chalk lines.



- ❑ 6. Fit the sheeting in place, removing a little wood at a time until the sheeting cleanly butts up against the transition stringers. Glue the sheeting in place.

- ❑ 7. Sand the transition stringers to the shape shown on the cross-sections on the plans. Sand the sheeting flush with the front and rear formers.

Mount the Stabilizer to the Fuselage

- ❑ 1. If you have not already done so, make sure the stab and fin are final sanded to a smooth finish as it will be a little more difficult to do so after they are glued to the fuselage.



- ❑ 2. Mount the wing to the fuselage, then position the stab on the fuselage. Stand about six to ten feet behind the

model and see if the stab is parallel with the wing. If necessary, use your bar sander to make adjustments by sanding the stab base until the stab is in alignment with the wing.

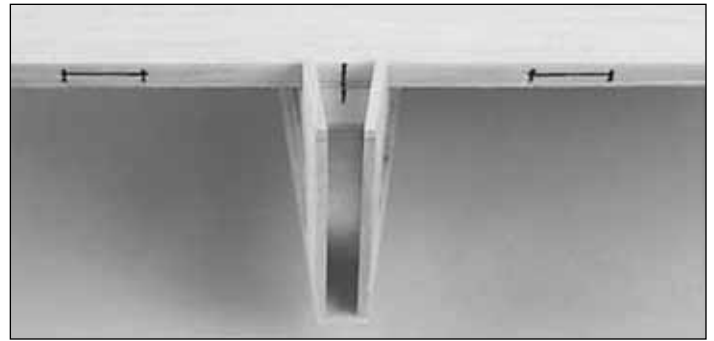

- ❑ 3. Accurately measure the trailing edge of the stabilizer and use a ballpoint pen to lightly mark the center. Use the same procedure to mark the rear center of the stab base where the trailing edge of the stab contacts it.

- ❑ 4. Place the stab on the stab base with the center marks aligned, then use a large T-pin to pin **only the trailing edge** of the stab to the stab base.

- ❑ 5. Stick a T-pin through the forward fuse deck sheeting above the forward front deck former in the center of the middle stringer, then use the "pin and string technique" to accurately align the stab with the fuselage. Once the stab is accurately aligned, pin the LE of the stab to the stab base.

- ❑ 6. Carefully turn the fuselage over and use a ballpoint pen to *lightly* mark where both fuselage sides contact the bottom of the stab.

- ❑ 7. Remove the stab from the stab base but leave the T-pins in the stab. Apply a film of 30-minute epoxy to the stab base and to the stab between the lines you marked indicating the fuselage sides.

- ❑ 8. Reposition the stab on the stab base and reinsert the T-pins into the same holes. Use the pin and string to confirm the stab alignment, then use weights, more T-pins or clamps to hold the stab in position. Wipe away excess epoxy before it cures. Recheck the alignment, then do not disturb the model until the epoxy cures.

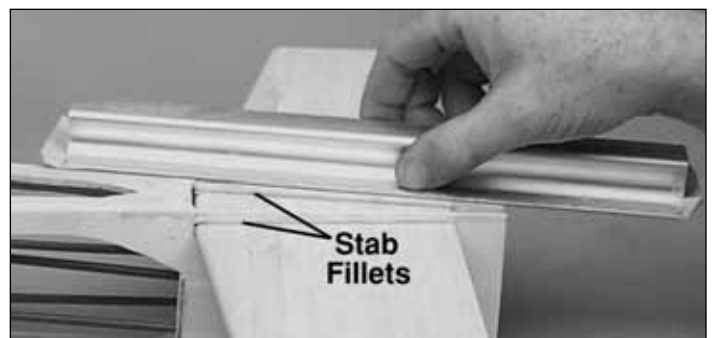

- ❑ 9. From the 3/16" x 3/16" x 18" balsa stick, fit, then glue the **stab fillets** in place. Sand them flush with the fuse top.

Mount the Fin

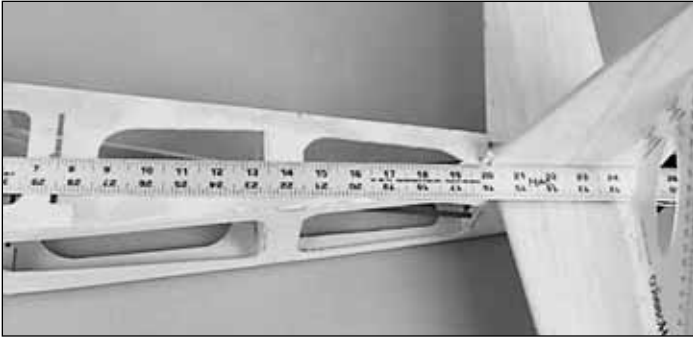

1. Fit the fin in place aligning it with a straightedge held against the side of the fin and the **edge** of the "V-notch" cut in the forward fuse top. **Note:** It is very important that the fin be accurately aligned with the fuse centerline.



2. Use your builder's triangle to check that the fin is perpendicular to the stab. Mark the stab on both sides of the fin.

3. Using 30-minute epoxy, glue the fin in place. Double-check that it is perpendicular and aligned with the centerline of the fuse.

Build the Turtle Deck

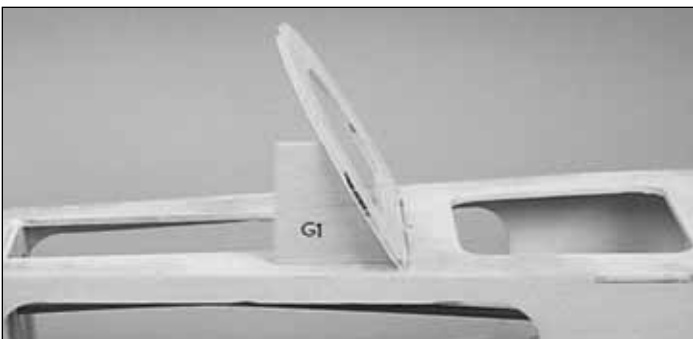

1. Glue the die-cut 1/8" ply **backrest (part #28)** to the fuse top, using the "backrest gauge" (**G1**) to set it at the correct angle. **Note:** The gauge is used only for setting the angle (do not glue the gauge in place).

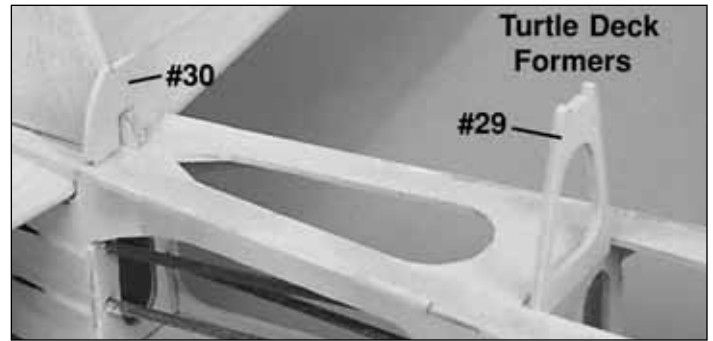

2. Use a square to position the die-cut 1/8" ply **turtle deck formers (part #'s 29 and 30)** vertically, 90° to the fuse top. **Note:** Part #29 glues to the front side of part #9, not on top of it. Check the plan for positioning, and glue these formers in place.

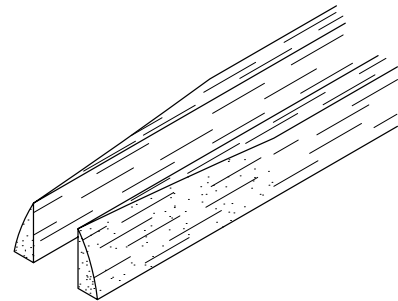

3. Cut two 13-1/2" long pieces from a 1/8" x 1/4" x 36" balsa stick making two **turtle deck top stringers**. Round the last 2" of each stringer as shown in the sketch so that the turtle deck sheeting will be able to fit flush against the fin.



4. Glue the stringers in place on the turtle deck formers and the fin, with the rounded end glued to the fin.

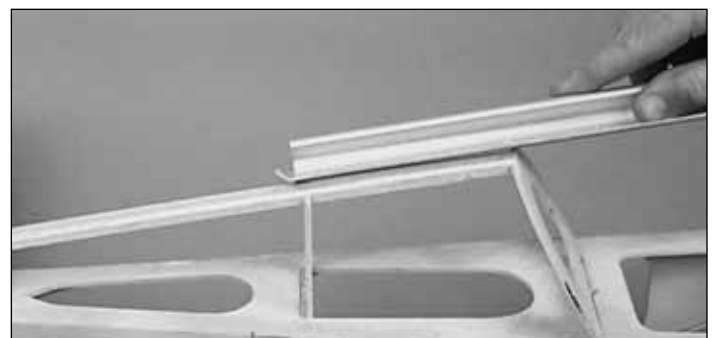

5. Sand the tops of the stringers to the shape of the turtle deck formers.

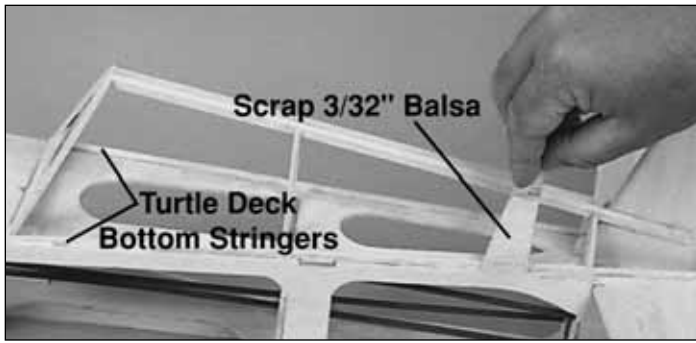

❑ 6. Cut a 1/8" x 1/8" x 36" balsa stick in half making two **turtle deck bottom stringers**. Glue them to the fuse top leaving a 3/32" space between the outer edge of the fuse side and the stringer. **Hint:** Using a leftover piece of 3/32" balsa as a spacer to locate the stringer makes this step easier.

❑ 7. Edge glue two 3/32" x 3" x 18" balsa sheets together, making a 6" x 18" sheet. Cut the two turtle deck sheets using the template on the fuse plan as a guide.

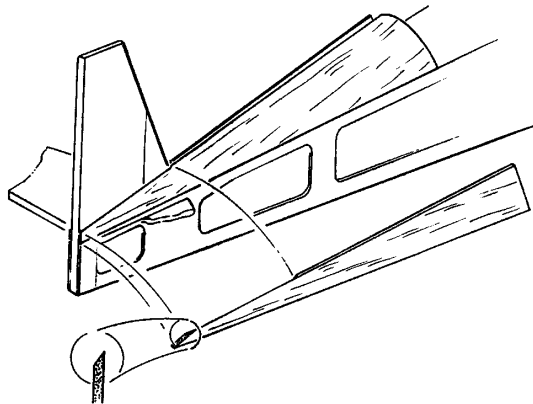

❑ 8. Sand a taper on the top rear 5" of the sheeting.

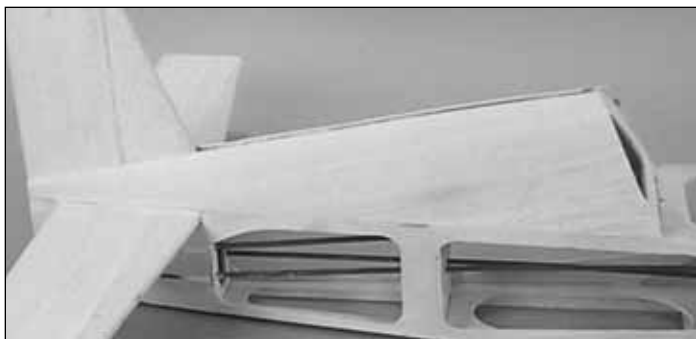

❑ 9. Glue the bottom edge of the sheeting to the fuse top and the bottom stringer. Wet the outside of the sheeting, then bend and glue the sheeting to the turtle deck formers, turtle deck top stringers and the fin.



❑ 10. Using your sanding block, sand the top edges of the sheeting so the top stringer will have a good gluing surface when it is glued in place.

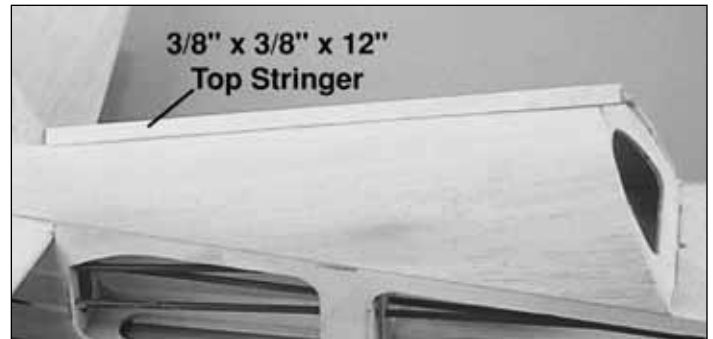

❑ 11. Glue the 3/8" x 3/8" x 12" balsa **top stringer** in place.



❑ 12. Shape the top stringer to the shape shown on the plans.

Mount the Engine & Tank Tray

❑ 1. Cut the "spreader bar" from the supplied Great Planes engine mount, then use a hobby knife to remove any flashing left over from the molding process so the halves fit together well.

❑ 2. Temporarily bolt the engine mount to the firewall with four 8-32 x 1-1/4" socket head bolts and #8 flat washers. Do not tighten the bolts all the way, because you still need to adjust the mount.

❑ 3. Place your engine on the mount and slide the halves in or out until the engine fits properly. Position the mount so the molded-in "tick marks" are equally spaced on the horizontal centerline you drew connecting the punch marks on both sides of the firewall. When the engine mount is adjusted and positioned, tighten the mounting screws.

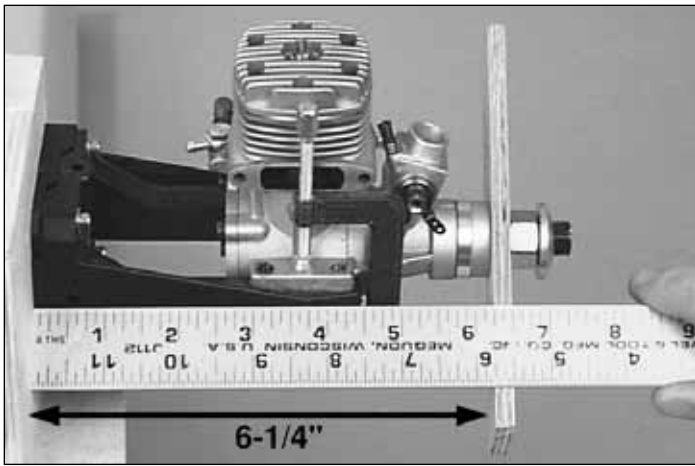

❑ 4. Position the engine on the mount so the drive washer (or the back of the spinner) is 6-1/4" away from the firewall and clamp in place.

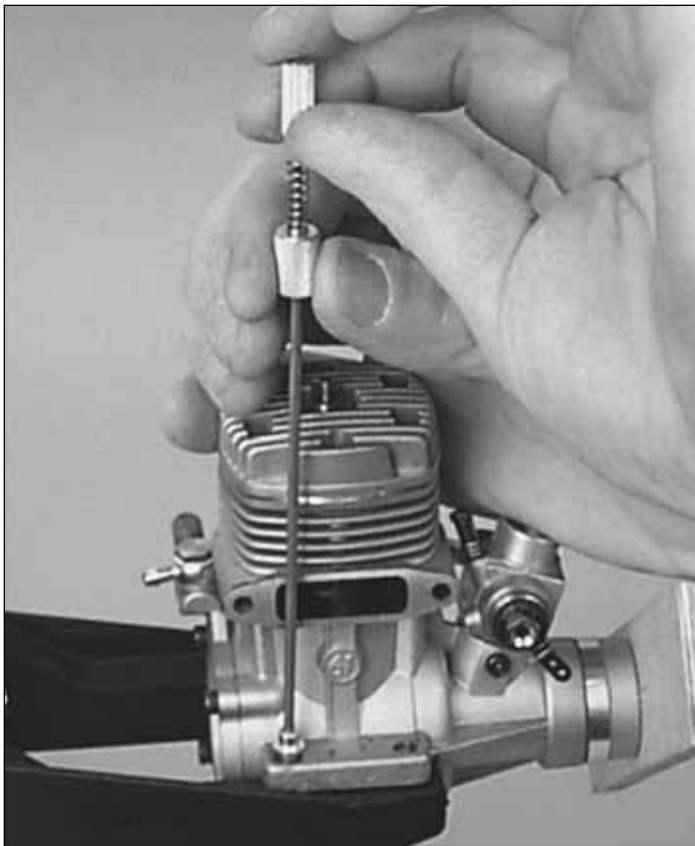

❑ 5. Use the Great Planes Dead Center™ Engine Mount Hole Locator (GPMP8130) to mark the locations of the bolt holes. Remove the engine from the mount and drill four 9/64" holes. Tap the engine mount with an 8-32 tap for the #8 x 3/4" socket head engine mounting bolts.

❑ 6. Glue the die-cut 1/8" ply **tank floor (part #13)** in place. **Note:** If you are using a pumped engine you can mount the fuel tank floor to part #26 and support it on both ends with leftover ply.

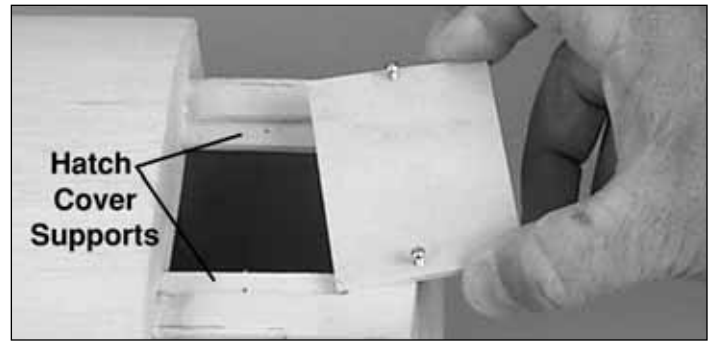

❑ 7. Glue the die-cut 1/8" ply **hatch cover supports** to the underside of the forward fuse top as shown on the plan. Test fit the hatch cover and make adjustments if needed. With the hatch cover in position, drill a 1/16" hole through the hatch cover and supports where indicated on the plan. Then, remove the hatch cover and drill 3/32" holes in the hatch cover only.

Install the Servos & Make the Pushrods

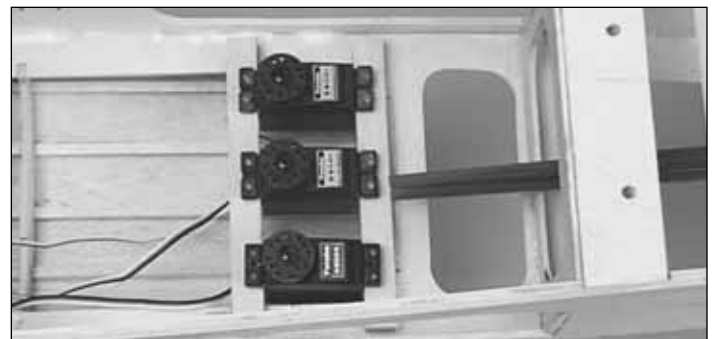

❑ 1. Glue the 3/8" x 1/2" x 5" basswood **rear servo rail** in place with medium CA, aligning it with part #27.

❑ 2. Use your servos to locate the 3/8" x 1/2" x 5" basswood **forward servo rail** and glue in place.



❑ 3. Cut the pushrod tubes roughly 1/2" in front of former 8 as shown in the photo. Save one of these cut off pieces for the throttle pushrod.

❑ 4. Use coarse sandpaper to roughen the outside of the throttle pushrod tube so glue will stick. Use medium CA to glue the pushrod tube into the firewall. Cut the pushrod tube flush with the outside of the firewall.

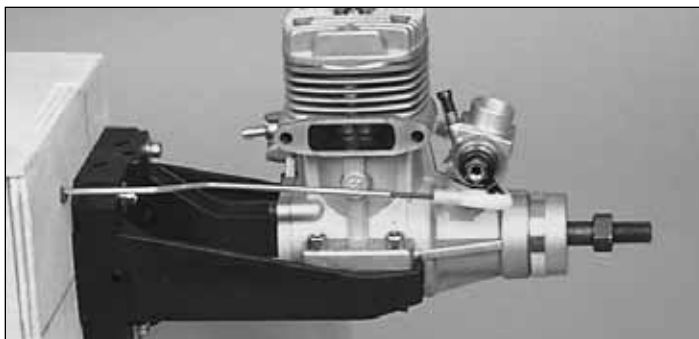

❑ 5. Bend and cut the 36" throttle pushrod wire (the one that is threaded on one end) to fit your engine installation, using the drawing on the fuselage plan as a guide. Install a nylon clevis and insert the pushrod through the guide tube. Make adjustments to the bends in the wire so the pushrod aligns with the carburetor arm on the engine. Then, temporarily connect the clevis to the carb arm. Temporarily mount the muffler and make sure the throttle pushrod will not interfere with the muffler. Make adjustments to the bends in the wire if necessary.

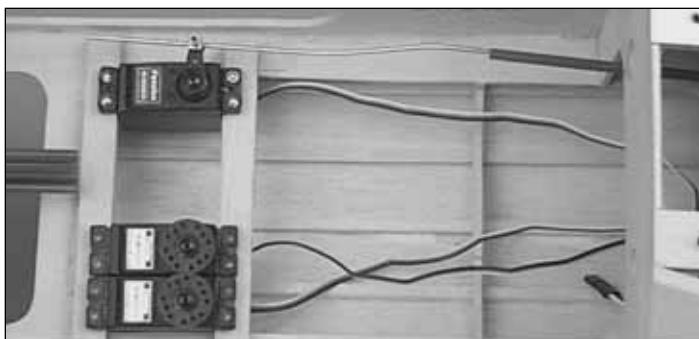

❑ 6. Temporarily install the brass Screw-Lock Pushrod Connector into the throttle servo arm, then adjust the bend in the throttle pushrod if necessary and fit it into the connector. When satisfied with the fit of the pushrod, mount the servo to the servo tray with the screws provided with your radio system.

❑ 7. Cut 8-1/4" off one end of one of the 35" wire pushrods (the ones that are threaded on both ends). Cut 9-3/8" off the end of the other 35" wire rod. Set the short pieces aside and save them for the aileron pushrods. Thread a nylon clevis about 20 turns onto the end of the long rod. Then, remove the **backing plate** from a **nylon control horn** and connect the horn to the clevis in the outer hole. Make another pushrod assembly from the other long rod with a clevis and control horn in the same manner.

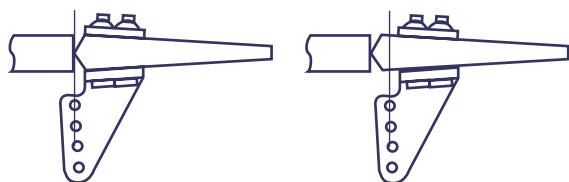

Correct

Incorrect



❑ 8. Insert the elevator pushrods into the pushrod tubes. Position the control horns on the elevators as shown in the sketch and on the plan. Use a ballpoint pen to mark the location of the control horn mounting holes and drill 3/32" holes at the marks. Temporarily mount the control horns to the elevators with the backing plates and 2-56 x 5/8" screws.



❑ 9. With the elevator servo set in place, make sure the servo arm is perpendicular to the pushrod and the control surfaces are in the neutral position. Use a felt-tip pen to mark where the longer pushrod crosses the mounting holes in the servo arm.

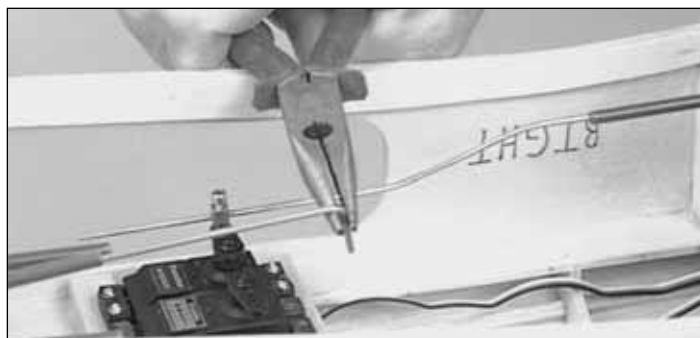

❑ 10. Disconnect the clevis from the control horn on the wire you marked. Make a 90° bend at the mark you made. Temporarily install a nylon Faslink on this pushrod, then cut the wire so it slightly protrudes out of the Faslink. **Hint:** If you prefer to bend and cut the pushrod **outside of the fuselage**, remove the pushrod, then make the 90° bends and cut the wire. Unscrew the clevis and reinstall the pushrod in the guide tube from the front, then screw the clevis back on.

❑ 11. Fit the 1/8" die-cut ply **pushrod support (part #36)** over the pushrod tubes. Glue the pushrod support to former 8 taking care to keep the pushrods straight.

❑ 12. Connect the pushrod to the servo with a nylon Faslink. **Note:** If necessary, enlarge the hole in the servo arm with a 5/64" drill bit (or a #48 bit for precision). Let the pushrod locate the servo (left to right), in the servo tray, then screw the elevator servo in place.

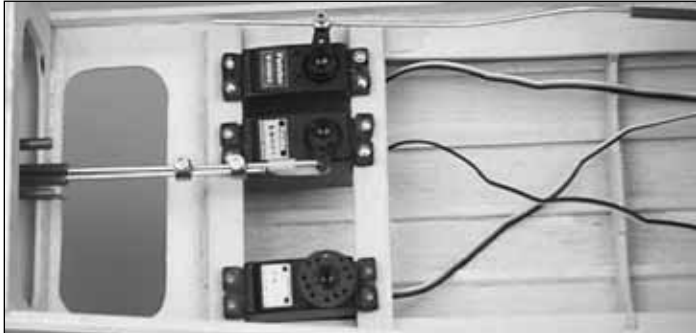

❑ 13. While keeping both elevators centered, connect the two elevator pushrods to each other with two 5/32" wheel collars and 6-32 x 1/8" set screws as shown in the photo. We recommend using thread locking compound on the set screw threads.

❑ 14. Mount the rudder with the hinges the same as you did with the elevators.

❑ 15. Mark the location of the tail gear wire on the rudder and the nylon tail gear bearing on the fuselage.

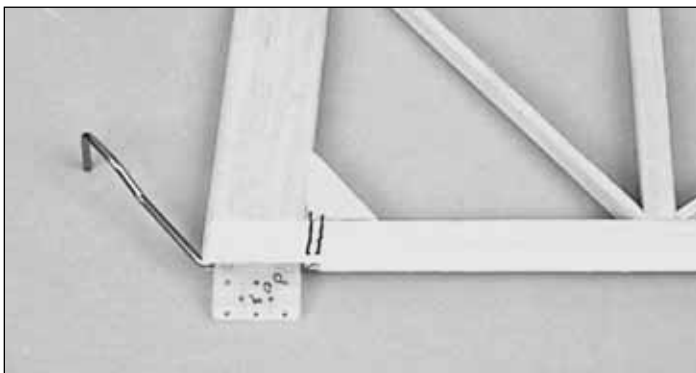

❑ 16. Remove the rudder and drill a 7/64" hole in the LE of the rudder at the mark you made for the tail gear wire. Cut a groove in the LE of the rudder for the nylon tail gear bearing. Test fit the tail gear wire in the rudder.

❑ 17. Cut a slot in the trailing edge of the fuse at the marks you made for the nylon tail gear bearing. Without using any glue, join the rudder to the fin with the tail gear wire in position.

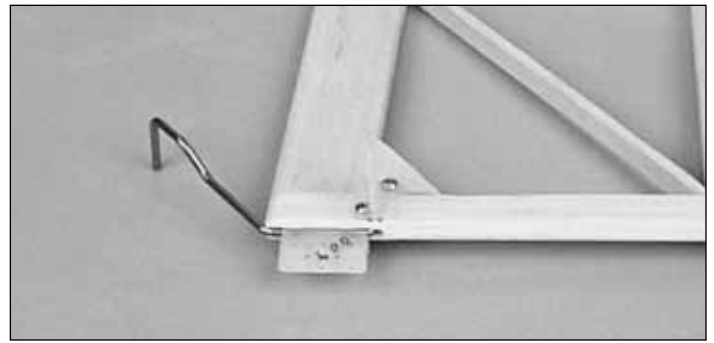

❑ 18. Mount the control horn to the rudder, trapping the tail gear wire between the screws.

❑ 19. Hook up the rudder pushrod the same as you did with the elevators.

❑ 20. Mount the aileron servos in the wing with the screws provided with the radio.

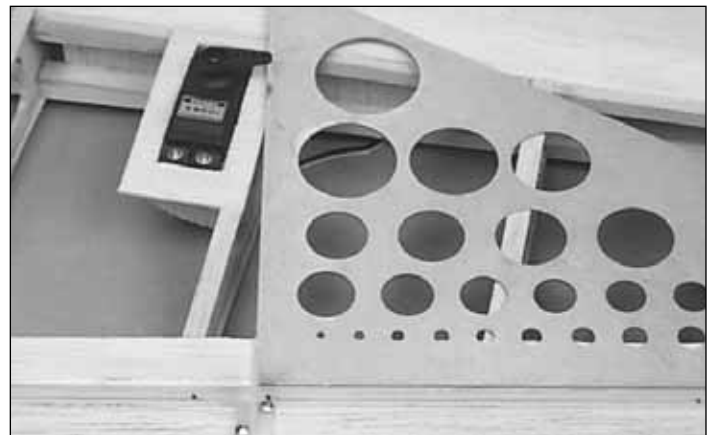

❑ 21. Locate the control horn on the aileron using a square so that the pushrod will be perpendicular to the hinge line. Mount the control horn and back plate with the 2-56 x 5/8" screws.

❑ 22. Screw the clevises twenty turns onto the 8-1/4" pushrod and the 9-3/8" pushrod.



23. Connect the clevis to the control horn. Center the aileron and the servo arm. Mark the pushrod where it crosses the servo arm. Bend the pushrod and connect it to the servo arm with a nylon Faslink. Trim the excess wire that protrudes past the nylon Faslink.



2. Use your bar sander to carefully true the edges of the overlapping pieces of the wheel pant halves so when you glue them together the seam will be as small and straight as possible. Notice that the front and rear of the wheel pant halves do not overlap and are “butt glued” together. Use 150 or 220-grit sandpaper to remove the flashing and **thoroughly** roughen all areas that are to be glued including the indentation on the inside of both inner wheel pant halves.

3. Test fit the wheel pant halves and make adjustments where necessary for the best possible fit.

4. Join two wheel pant halves and carefully spot glue them together in just a few places with thin CA. Start by spot gluing the top, then the front and rear where the two halves just butt together. After the halves are joined, securely glue them together along all the seams with thin CA. **Note:** Do not use CA accelerator on the ABS plastic as it may develop cracks and/or keep the paint from adhering.

5. Use your hobby knife or a Dremel® Moto-Tool™ with a sanding drum to cut out the wheel openings. **Hint:** Make the wheel openings wide as this will make installing the wheels and axles easier and cause less interference with the wheels upon landing and takeoff. You can see the size of the wheel openings in the following photo.



6. Use medium CA to glue the die-cut 1/8" plywood wheel pant mounts to the inside of each wheel pant.

Assemble the Wheel Pants



1. Trim one matching set of wheel pant halves along the molded cut lines. Notice that the **top** of the outer pant goes over the lip of the inner pant and the **bottom** of the inner pant goes over the lip of the outer pant. You can use a hobby knife to **carefully** score along the cut lines and flex the plastic until the excess breaks free, or use small scissors to cut along the lines. Hobbico curved tip canopy scissors (HCAR0667) work extremely well for this and make the job a cinch. For now, don't worry about accurately cutting out the opening in each wheel pant half—just cut an approximate opening for the wheels.



7. Use a metal file to chamfer the edges and corners of the aluminum landing gear so it will neatly fit in the recess of the wheel pant. Position the wheel pant on the aluminum landing gear. Drill a 3/16" hole through the wheel pant using the landing gear as a guide.



8. Drill a 3/16" hole through the outside of the wheel pant using the inside hole as a guide. Enlarge the hole to 1/4" so the head of the 8/32 bolts, provided for axles will fit. **Note:** It is not necessary to drill the hole perfectly straight across from the first hole, but you should try to be close.

9. Most 2-3/4" wheels are made to fit 5/32" axles, but the 8-32 bolts supplied in this kit for the axles require a larger hole. If the wheel does not roll freely on the 8-32 x 1-1/2" bolt "axle," enlarge the wheel hub with an 11/64" (#18 for perfection) drill.

10. Test fit the wheel in the wheel pant using the following procedures:

A. Set the wheel in the wheel pant.



B. Insert the 8-32 x 1-1/2" bolt "axle" part way into the wheel through the 1/4" hole in the outside of the wheel pant. Hold an 8-32 nut with a needle nose pliers inside the wheel pant. Use a 9/64" hex wrench to screw the axle through the nut and through the wheel pant mount.

C. Adjust the tightness of the nut with a hemostat or needle nose pliers.



11. Temporarily mount the wheel pant to the landing gear with another 8-32 nut on each axle.

12. Perform the same procedure to assemble and temporarily mount the other wheel pant to the landing gear.



13. Before painting the wheel pants, fill the seams with putty filler such as Squadron® White Putty or resin filler such as Bondo®. We use Bondo most of the time as it cures quickly and is easy to sand, but usually it must be purchased in large quantities. Squadron putty works well but it takes overnight to dry and usually requires at least two applications because it shrinks as it dries.

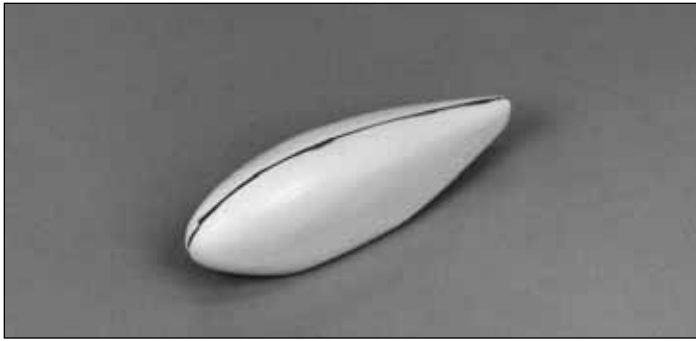

❑ 14. After the filler cures, wet sand the wheel pants with 400-grit sandpaper to prepare them for primer.

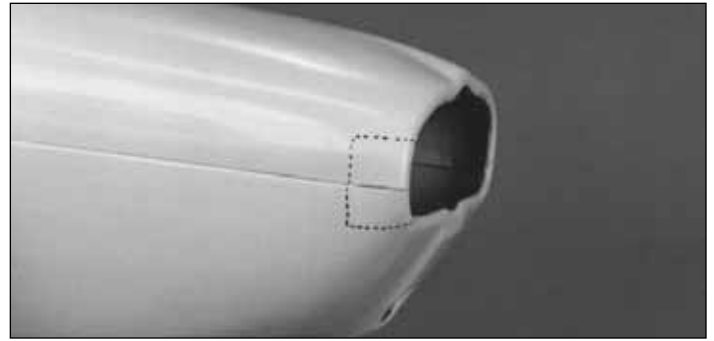

❑ 5. Use 30-minute epoxy to glue a 1" strip of glass cloth across the glue joint inside the front of the cowl on both sides.

Assemble the Cowl

❑ 1. The cowl is assembled the same as the wheel pants. Cut the cowl along the cut lines, then use your bar sander to true all the edges. For now, the opening in the front of each cowl half only needs to be roughly cut out. Use coarse sandpaper to roughen all the overlapping areas so the glue will stick.

❑ 2. Tape the two pieces together, then wick a small amount of thin CA along the seams of the overlapping joints. After the CA has cured remove the tape and make sure you have thoroughly glued the two pieces together by inspecting the glue joints and adding thin CA if necessary.

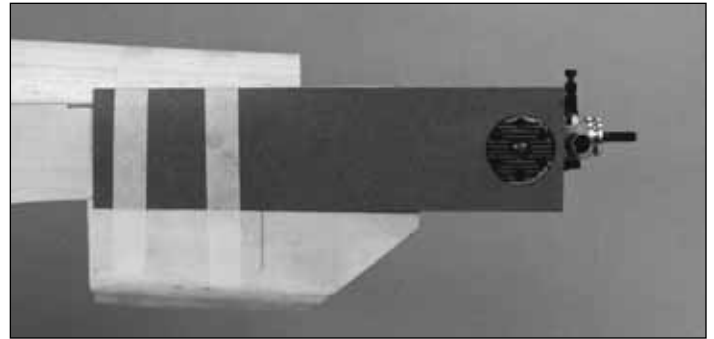
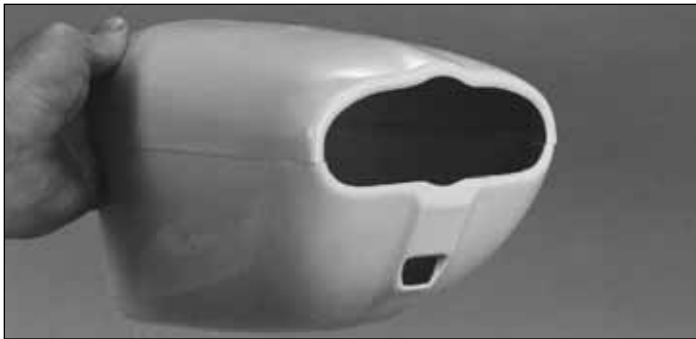

❑ 6. Use a piece of thin cardboard or plastic to make a template for the cutout in the cowl for the head of the engine. Tape the template to the fuselage side, accurately indicating the position of the head.



❑ 3. Use a sharp hobby knife or a Dremel Multi-Tool with a sanding drum to accurately cut the engine openings at the front of the cowl and the air exit at the rear of the cowl.

❑ 4. Use coarse sandpaper to thoroughly scuff the inside of the front of the cowl on both sides where there is no overlapping glue joint.

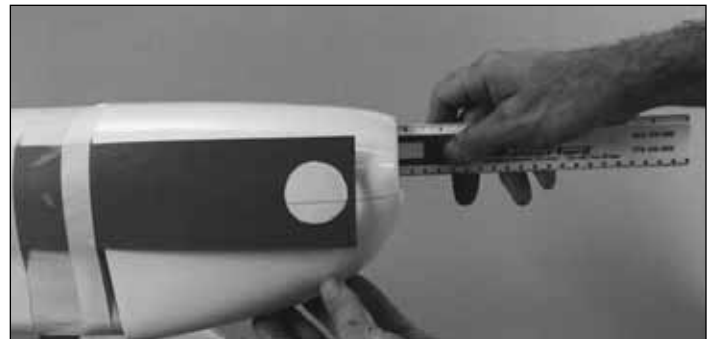

❑ 7. Place the backplate of your spinner on the engine and measure the distance between the firewall and the backplate (it should be 6-1/4"). Remove the engine from the fuselage, then position the cowl on the fuselage so it is 1/8" aft of the measurement you just made. Use a ballpoint pen to lightly mark the location of the rear of the cowl on the fuselage top.



❑ 8. Align the cowl with the mark you made on the fuselage, then use a felt-tip pen to transfer the hole in the template onto the cowl. **Note:** The circle you marked on the cowl may be slightly aft of the **actual position** of the head of the engine due to the upward sweep of the template when the cowl is in position. **Hint:** For the most accuracy, leave the engine mounted to the fuselage but remove only the cylinder head. Position the cowl, then install the spinner back plate on the engine. Align the cowl with the spinner back plate (instead of the reference line you marked on the fuselage top), *then* transfer the hole in the template onto the cowl.

❑ 9. Remove the cowl and template, then remount the engine (or the cylinder head). Cut out the hole in the cowl, then test fit it to the fuselage (you may have to temporarily remove the needle valve so it does not interfere with the cowl). Adjust the position and size of the hole as needed. The location of the hole determines the clearance between the front of the cowl and the back plate of the spinner. **Hint:** Cut the hole in the cowl undersize at first so you can make adjustments to its position without having to oversize it.

❑ 10. Once you have made the hole in the cowl to clear the engine, place the cowl on the fuselage and fit the back plate of your spinner on the engine. Tape the cowl to the fuse.

❑ 11. Making one hole at a time and checking to be sure the cowl still lines up with the spinner back plate, drill one 3/32" hole through the cowl and the fuse side at one of the locations shown on the plan. Using a #4 x 1/2" screw, attach the cowl to the fuse. Do the same for the other three cowl mounting screws, checking alignment before drilling each one.

❑ 12. Remove the spinner backplate and the cowl from the fuselage. Use a drop of thin CA to harden the screw holes in the fuse.

❑ 13. Cut four 1" x 1" pieces of fiberglass cloth. Use 30-minute epoxy to glue one piece to the inside of the cowl at each cowl mounting hole. After the epoxy cures, re-drill the holes with a 1/8" drill bit.

BALANCE THE MODEL Laterally

Do not confuse this procedure with “checking the C.G.” or “balancing the airplane fore and aft.” That very important step will be discussed later in the manual.

❑ 1. With the wing level and attached to the model (and the engine and muffler installed), lift the model by the propeller shaft and the fin. This may require an assistant. Do this several times.

❑ 2. The wing that consistently drops indicates the heavy side. Balance the model by adding weight to the other wing tip.

Note: An airplane that is laterally balanced will track better during aerobatic maneuvers than one that is not.

PREPARE THE MODEL FOR COVERING

❑ 1. If you've hooked up the pushrods to the servos before you covered the model, disconnect and remove all the pushrods and remove the hinges and control horns from the ailerons, elevators and rudder. Remove the engine mount and any other hardware you may have installed.



This step is optional but will enhance the scale appearance of your Extra 300S.

❑ 2. Test fit the die-cut 1/8" plywood **fuselage side stringers (part #'s 34 and 35)** in the fuselage sides as shown on the plans. Then, use medium CA to glue them into position.

❑ 3. Most of the model should be rough-sanded by now with all the tabs and rough edges sanded even. Fill all dents, seams, low spots and notches with HobbyLite™ balsa colored filler.

❑ 4. After the filler has dried, use progressively finer grades of sandpaper to even all the edges and seams and smooth all surfaces. Remove all balsa dust from the model with compressed air or a vacuum with a brush and a tack cloth.

COVER THE MODEL WITH MONOKOTE™ FILM

Covering Technique

Cover the model with **Top Flite MonoKote Film** using the recommended covering sequence that follows. Before you cover the fuselage, first apply 1/4" wide strips of MonoKote film in the corners of the stab and fuse and the fin and the fuse. Then, proceed to cover the fin and stab with pre-cut pieces that meet in the corners and overlap the 1/4" strips. **Never cut the covering on the stab and fin after it has been applied except around the leading and trailing edges at the tips.** Modelers who do this may cut through the covering and into the stab or fin. This will weaken the structure to a point where it may fail during flight.

Since the tips of the elevators and stab are squared off it is easiest to cover the tips before you cover the tops and bottoms. Do the same for the fin, rudder and the wing.

Some modelers drill a small hole in each stab rib and the trailing edge of the stab to allow expanded gas to exit while heating the MonoKote film. This keeps the covering from "ballooning" and allows you to securely bond it to the entire stab. The same thing can be done with the elevators, fin and rudder.

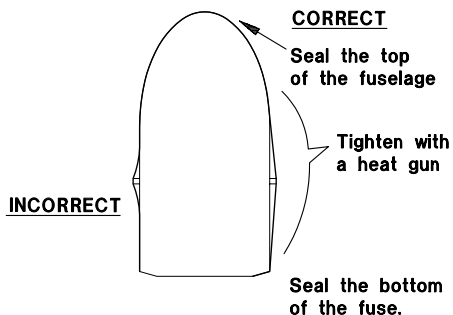

When you cover the fuselage, use your covering iron to seal only the **top of the turtle deck in the center**, and the **bottom of the fuse**. Use your heat gun to shrink the rest of the covering on the fuselage—especially near the side stringers. This will provide a realistic, smooth transition from the turtle deck, over the side stringers, down to the fuse bottom.

Since the ailerons are long "strip" ailerons some modelers prefer to cover the top and bottom with one strip of MonoKote film by covering the bottom first, then wrapping it around the leading edge over the top.

Suggested Covering Sequence

Fuselage

1. 1/4" strips at fin and stab as described
2. Aft fuse bottom
3. Forward fuse bottom
4. Fuse right side up to the center of the turtle deck
5. Fuse left side up to the center of the turtle deck, overlapping by 1/8"
6. Forward fuse deck top
7. Fin tip, then stab tips
8. Stab bottom, then top
9. Fin right side, then left side
10. Elevator tips and root ends
11. Elevator bottoms, then tops
12. Rudder tip, right side, then left side
13. Cockpit

Wing

1. Wing root spacers
2. Wing tips
3. Trailing edges of wing and inboard portion of tips and center leading edges
4. Belly pan bottom, then sides
5. Bottom of right, then left panel
6. Top of right, then left panel
7. Aileron tips, then bottom, then top of aileron

PAINTING

After the model is covered, use fuelproof model paint, 30-minute epoxy thinned with alcohol or finishing resin to coat areas that may be exposed to raw fuel or exhaust residue. These are areas such as the firewall, front and back of the belly pan, fuse openings for the wing and fuse doubler, fuel compartment hatch and the fuse top forward of the sheeting.

Top Flite LustreKote™ fuelproof paint is recommended for painting all the ABS plastic parts and the aluminum landing gear. The wheel pants should be removed from the landing gear for painting. Use a file to round the corners of the aluminum landing gear before you paint it. At least one coat of LustreKote primer is highly recommended to fill all the small scratches left from sanding as well as small pin holes in the Bondo filler. Wet sand between coats with 400-grit sandpaper and apply a second coat of primer if necessary. If the parts are primed properly, only one coat of color should be required.

Before painting the canopy, use scissors or a hobby knife to trim it along the molded-in cut lines, then true the edges with your bar sander and 220-grit sandpaper. Use 400-grit sandpaper to scuff the frame portion of the canopy so the paint will stick. We recommend you paint the canopy frame with Pactra® Formula-U or Chevron® Perfect Paint. Use masking tape to cover the portion of the canopy that is not to be painted. If you are not sure that the paint is

compatible with the clear canopy, test the paint on a leftover piece of canopy material.

For painting the pilot we have discovered that acrylic water base paints such as the types found at craft stores work great. The acrylic paints look realistic on the pilot because they are not glossy and best of all, they clean-up with water.

FINAL HOOKUPS & CHECKS

Join the Control Surfaces

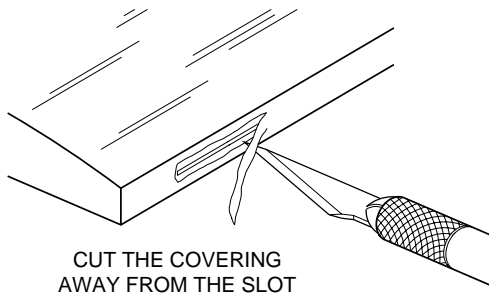

- ❑ 1. Start with the elevators and stab. Cut the covering from the hinge slots—don't just slit the covering but remove a small strip the size of the hinge slot.

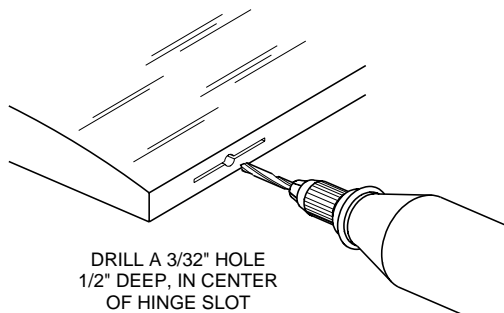

- ❑ 2. Drill a 3/32" hole 1/2" deep in the center of each hinge slot. A high speed Dremel Multi-Tool works best for this. If you use a slower speed drill, clean out the hinge slots with your #11 blade.

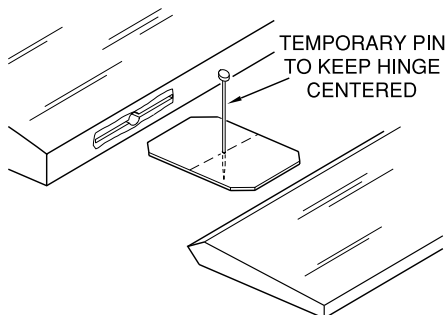

- ❑ 3. Without using any glue, test fit the hinges in the elevators or stab. Do not glue the hinges yet. As you join

the elevators to the stab, confirm that the hinges are equally inserted in the elevators and the stab. Insert a small pin in the center of the hinges to keep them centered.

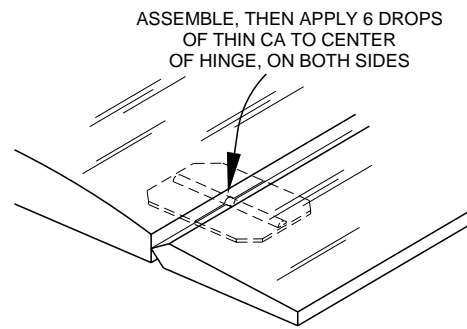

THE CA WICKS ALONG THE "TUNNELS" TO THE ENTIRE HINGE SURFACE

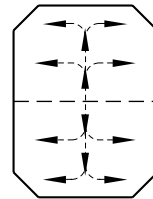

- ❑ 4. Remove the pin and add 6 drops of thin CA to the center of all the hinges on both the top and the bottom.

Do not use accelerator on any of the hinges. Do not glue the hinges with anything but thin CA and do not attempt to glue one half of the hinge at a time with medium or thick CA. They will not be properly secured and the controls could separate while the model is in flight.

- ❑ 5. Join the rudder to the fin with the hinges and use 30-minute epoxy to simultaneously glue the tail gear wire in the rudder and the tail gear bearing in the fuse. Do not glue the nylon bearing to the rudder. Glue the hinges in position with thin CA.

- ❑ 6. Prepare the hinge slots in the ailerons the same way you did for the tail surfaces. Glue the hinges with thin CA.

Install the Hardware

- ❑ 1. Assemble the fuel tank per the manufacturer's instructions. Install it in the fuse with approximately 12" of fuel line on the pickup and the vent lines on the tank.

- ❑ 2. Install a 1" tail wheel with a 3/32" wheel collar.

- ❑ 3. Install the wheels in the wheel pants, then mount the wheel pants to the landing gear. Secure the 8-32 nuts with a drop of thread lock.

- ❑ 4. Mount the landing gear to the fuselage with the #8 x 5/8" truss head screws and #8 washers.

❑ 5. Install the elevator, rudder and throttle pushrods, then install the control horns and hook them up the same way you did earlier.

❑ 6. Wrap the receiver and battery pack in at least 1/4" of foam rubber, then fit them in the location shown on the plans. Pack extra foam in the compartment to keep the receiver and battery pack from dislodging during aerobatics or a rough landing.

❑ 7. Mount the receiver switch in a convenient location that will not interfere with the servos and pushrods inside the fuselage.

❑ 8. Route the receiver antenna. On our prototype we used the fourth pushrod tube to route the antenna to the rear of the fuse, then taped it to the fuse.

❑ 9. Some modelers prefer to cushion the wing with wing seating foam tape on the wing saddle of the fuselage. Apply 1/16" wing seating foam tape to the wing saddle of the fuselage, if you choose.

❑ 10. Prepare the engine compartment for installing the cowl by connecting the fuel lines, installing the fuel filling valve, mounting the muffler and connecting the throttle pushrod. Install the cowl, then mount the spinner back plate, prop, prop washer and prop nut. Install the spinner.



❑ 3. Use a sharp #11 blade to **carefully** cut the covering about 1/32" inside of the line you marked **without cutting into the balsa**. Wipe away the ink line with a paper towel lightly dampened with alcohol.

❑ 4. Before you permanently glue the canopy to the fuselage, securely glue your pilot in place. For the most security, screw the base of the pilot to the cockpit floor with two #4 or #6 sheet metal screws from the underside of the cockpit floor. Place the instrument panel decal on the instrument panel.

❑ 5. Reposition the canopy on the fuselage and confirm that it covers the exposed wood. Glue the canopy to the fuselage using rubber bands or masking tape to hold it in position until the glue dries. We recommend a glue specifically formulated for gluing on canopies such as Pacer "Formula 560" canopy glue. Formula 560 is like regular white glue (aliphatic resin) in that it dries clear and cleans-up with water but sticks extremely well to butyrate and dries overnight (to allow for accurate positioning).

Set the Control Throws

Attach the Canopy



❑ 1. Place the canopy on the fuselage in the location shown on the plans, then temporarily hold it in position with tape or rubber bands.

❑ 2. Use a felt-tip pen to **accurately** trace the canopy outline onto the MonoKote film covering. Remove the canopy.

4-CHANNEL RADIO SET-UP (STANDARD MODE 2)

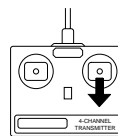

ELEVATOR MOVES UP

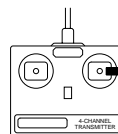

RIGHT AILERON MOVES UP
LEFT AILERON MOVES DOWN

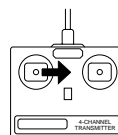

RUDDER MOVES RIGHT

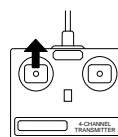

CARBURETOR WIDE OPEN

We recommend the following control surface throws:

Note: The throws are measured at the widest part of the elevators, rudder, and ailerons. Adjust the position of the pushrods at the control/servo horns to control the amount of throw. You may also use the ATV's if your transmitter has them but the mechanical linkages should still be set so the ATV's are near 100% for the best servo resolution (smoothest, most proportional movement).

	High Rate	Low Rate
ELEVATOR:	1-1/4" up 1-1/4" down	3/4" up 3/4" down
RUDDER:	2-1/2" right 2-1/2" left	1-1/2" right 1-1/2" left
AILERONS:	5/8" up 5/8" down	1/4" up 1/4" down

Note: If your radio does not have dual rates, then set the control surfaces to move between the high rate and low rate throws.

Note: The balance and control throws for the Extra 300S have been extensively tested. We are confident that they represent the settings at which the Extra 300S flies best. Please set up your model to the specifications listed above. If, after you become comfortable with your Extra 300S, you would like to adjust the throws to suit your tastes, that's fine. Too much throw can force the plane into a stall or snap roll, so remember, "more is not better."

BALANCE YOUR MODEL

Note: This section is VERY important and must NOT be omitted! A model that is not properly balanced will be unstable and possibly unflyable.

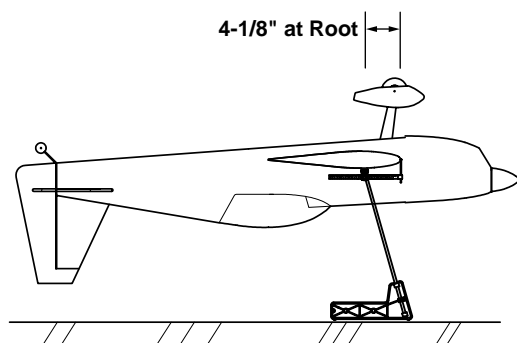

1. Accurately mark the balance point on the top of the wing on both sides of the fuselage. Use thin strips of tape or a felt-tip pen to make the marks. The balance point (C.G.) is located **4-1/8" back from the leading edge** as shown in the sketch and on the wing plan. Balance your Extra 300S using a Great Planes C.G. Machine™ Airplane

Balancer (GPMR2400) for the most accurate results. **Hint:** Reference the full-size wing plan to help you locate the proper balance point. This is the balance point at which your model should balance for your first flights. After initial trim flights and when you become more acquainted with your Extra 300S, you may wish to experiment by shifting the balance up to **3/8" forward or back** to change the flying characteristics. Moving the balance **forward** may improve the smoothness and stability but the model may then require more speed for takeoff and make it more difficult to slow for landing. Moving the balance **aft** makes the model **more agile** with a lighter, snappier "feel" and often improves knife-edge capabilities. In any case, **please start at the location we recommend and do not at any time balance your model outside the recommended range.**

2. With the wing attached to the fuselage, all parts of the model installed (ready to fly) and an **empty** fuel tank, hold the model upside-down with the stabilizer level.

3. Lift the model at the balance point. If the tail drops when you lift, the model is "tail heavy" and you must add weight* to the nose to balance the model. If the nose drops, it is "nose heavy" and you must add weight* to the tail to balance the model. **Note:** Nose weight may be easily installed by using a "spinner weight" or gluing lead weights to the firewall. Tail weight may be added by using Great Planes (GPMQ4485) "stick-on" lead weights. Later if the balance is O.K., you can open the fuse bottom and glue the weights in permanently.

** If possible, first attempt to balance the model by changing the position of the receiver battery and receiver. If you are unable to obtain good balance by doing so, then it will be necessary to add weight to the nose or tail to achieve the proper balance point.*

PREFLIGHT

At this time check all connections including servo arm screws, faslinks, clevises and servo cords. Make sure you have installed the **nylon retainer** on the Screw-Lock Pushrod Connector on the throttle pushrod at the servo arm and the **silicone retainers** on all the clevises.

Charge the Batteries

Follow the battery charging procedures in your radio instruction manual. You should **always** charge your transmitter and receiver batteries the night before you go flying and at other times as recommended by the radio manufacturer.

Balance the Propeller

Balance your propellers carefully before flying. An unbalanced prop is the single most significant cause of vibration. Not only may engine mounting screws vibrate out, possibly with disastrous effect, but vibration may also damage your radio receiver and battery. Vibration may cause your fuel to foam, which will, in turn, cause your engine to run lean or quit.

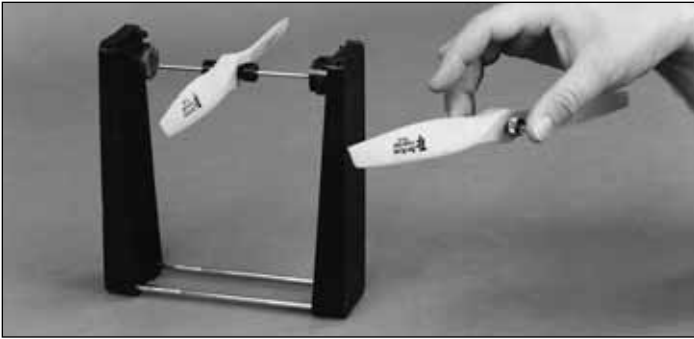

We use a **Top Flite Precision Magnetic Prop Balancer** (TOPQ5700) in the workshop and keep a **Great Planes Fingertip Balancer** (GPMQ5000) in our flight box.

Find a Safe Place to Fly

Since you have chosen the Extra 300S we assume that you are an experienced modeler. Therefore, you should already know about AMA chartered flying fields and other safe places to fly. If, for some reason you are a relatively inexperienced modeler, and have not been informed, we strongly suggest that the best place to fly is an AMA chartered club field. Ask the AMA or your local hobby shop dealer if there is a club in your area and join. Club fields are set up for R/C flying and that makes your outing safer and more enjoyable. The AMA address and telephone number is in the front of this manual.

If a club and flying site are not available, find a large, grassy area at least 6 miles away from houses, buildings and streets and any other R/C radio operation like R/C boats and R/C cars. A schoolyard may look inviting but is too close to people, power lines and possible radio interference.

Ground Check the Model

If you are not thoroughly familiar with the operation of R/C models, ask an experienced modeler to inspect your radio installation and confirm that all the control surfaces respond correctly to transmitter inputs. The engine operation must also be checked by confirming that the engine idles reliably and transitions smoothly and rapidly to full power, and maintains full power indefinitely. The engine must be "broken-in" on the ground by running it for at least two tanks of fuel. **Follow the engine manufacturer's**

recommendations for break-in. Make sure all screws remain tight, that the hinges are secure and that the prop is on tight.

Range Check Your Radio

Whenever you go to the flying field, check the operational range of the radio before the first flight of the day. First, make sure no one else is on your frequency (channel). With your transmitter antenna collapsed and the receiver and transmitter on, you should be able to walk at least 100 feet away from the model and still have control. While you work the controls have a helper stand by your model and tell you what the control surfaces are doing.

Repeat this test **with the engine running** at various speeds with a helper holding the model. If the control surfaces are not always responding correctly, **do not fly!** Find and correct the problem first. Look for loose servo connections or corrosion, loose bolts that may cause vibration, a defective on/off switch, low battery voltage or a defective cell, a damaged receiver antenna, or a receiver crystal that may have been damaged from a previous crash.

Engine Safety Precautions

Note: Failure to follow these safety precautions may result in severe injury to yourself and others.

Keep all engine fuel in a safe place, away from high heat, sparks or flames as fuel is very flammable. Do not smoke near the engine or fuel; and remember that the engine exhaust gives off a great deal of deadly carbon monoxide. **Do not run the engine in a closed room or garage.**

Get help from an experienced pilot when learning to operate engines.

Use safety glasses when starting or running engines.

Do not run the engine in an area of loose gravel or sand; the propeller may throw such material in your face or eyes.

Keep your face and body as well as all spectators away from the plane of rotation of the propeller as you start and run the engine.

Keep these items away from the prop: loose clothing, shirt sleeves, ties, scarfs, long hair or loose objects such as pencils, screwdrivers that may fall out of shirt or jacket pockets into the prop.

Use a "chicken stick" or electric starter; follow instructions supplied with the starter or stick. Make certain the glow plug clip or connector is secure so that it will not pop off or otherwise get into the running propeller.

Make all engine adjustments from **behind** the rotating propeller.

The engine gets hot! Do not touch it during or after operation. Make sure fuel lines are in good condition so fuel will not leak onto a hot engine causing a fire.

To stop the engine, cut off the fuel supply by closing off the fuel line or follow the engine manufacturer's recommendations. Do not use hands, fingers or any body part to try to stop the engine. Do not throw anything into the propeller of a running engine.

AMA SAFETY CODE (excerpt)

Read and abide by the following Academy of Model Aeronautics Official Safety Code:

General

1. I will not fly my model aircraft in sanctioned events, air shows, or model flying demonstrations until it has been proven to be airworthy by having been previously successfully flight tested.

2. I will not fly my model aircraft higher than approximately 400 feet within 3 miles of an airport without notifying the airport operator. I will give right of way to, and avoid flying in the proximity of full scale aircraft. Where necessary an observer shall be used to supervise flying to avoid having models fly in the proximity of full scale aircraft.

3. Where established, I will abide by the safety rules for the flying site I use, and I will not willfully and deliberately fly my models in a careless, reckless and/or dangerous manner.

7. I will not fly my model unless it is identified with my name and address or AMA number, on or in the model.

9. I will not operate models with pyrotechnics (any device that explodes, burns, or propels a projectile of any kind).

Radio Control

1. I will have completed a successful radio equipment ground check before the first flight of a new or repaired airplane.

2. I will not fly my model aircraft in the presence of spectators until I become a qualified flier, unless assisted by an experienced helper.

3. I will perform my initial turn after takeoff away from the pit or spectator areas, and I will not thereafter fly over pit or spectator areas, unless beyond my control.

4. I will operate my model using only radio control frequencies currently allowed by the Federal Communications Commission.

FLYING

CAUTION (THIS APPLIES TO ALL R/C AIRPLANES):

If, while flying, you notice any unusual sounds, such as a low-pitched "buzz", this may indicate control surface "flutter." Because flutter can quickly destroy components of your airplane, any time you detect flutter you must **immediately** cut the throttle and land the airplane! Check all servo grommets for deterioration (this may indicate which surface fluttered), and make sure all pushrod linkages are slop-free. If it fluttered once, it will probably flutter again under similar circumstances unless you can eliminate the slop or flexing in the linkages. Here are some things which can result in flutter: Excessive hinge gap; Not mounting control horns solidly; Sloppy fit of clevis pin in horn; Elasticity present in flexible plastic pushrods; Side-play of pushrod in guide tube caused by tight bends; Sloppy fit of Z-bend in servo arm; Insufficient glue used when gluing in the elevator joiner wire or aileron torque rod; Excessive flexing of aileron, caused by using too soft balsa; Excessive "play" or "backlash" in servo gears; and Insecure servo mounting.

The Great Planes Extra 300S is a great flying semi-scale sport model that flies smoothly and predictably, yet is highly aerobatic. The Extra does not, however, possess the self-recovery characteristics of a primary R/C trainer and should only be flown by experienced RC pilots. This plane is fully capable of performing a full range of aerobatics - from simple loops and rolls to impressive Lomcevaks. The Extra 300S is limited only by your flying abilities and imagination. *Have Fun!*

Takeoff

Takeoff on "low" rates if you have dual rates on your transmitter—especially if you are taking off in a crosswind. For all models it is good practice to gain as much speed as the length of the runway will permit before lifting off. This will give you a safety margin in case the engine quits. When you initially advance the throttle and the tail begins to lift, the Extra will begin to turn to the left (due to the torque of the engine—a characteristic of all taildraggers). Be prepared for this by applying sufficient right rudder to keep the Extra running straight down the middle of the runway (or flying field). The left turning tendency will decrease as the plane picks up speed. Be sure to allow the tail to rise off the ground before lifting the model into the air. Depending on the surface you are taking off from, you will need to apply little or no up elevator until flying speed is reached. Don't hold the tail on the ground with too much up elevator, as the Extra will become airborne prematurely and may

stall. When the plane has gained enough flying speed to safely lift off, gradually and smoothly apply up elevator and allow the model to climb at a shallow angle (do not yank the model off the ground into a steep climb!).



Flying

We recommend that you take it easy with your Extra 300S for the first several flights, gradually “getting acquainted” with this great sport model as your engine gets fully broken in. If you feel as though you have your hands full, keep this one thing in mind: **pull back on the throttle stick to slow the model down.** This will make everything happen a little slower and allow yourself time to think and react. Add and practice one maneuver at a time, learning how the Extra behaves in each. For smooth flying and normal maneuvers, use the low rate settings as listed on page 43. High rate elevator may be required for crisp snap rolls and spins. For good knife-edge performance airspeed is the key.

Sometime well before it's time to land you should climb your Extra to a safe altitude and cut the throttle to an idle and check out the model's low speed characteristics. Do this a few times so you know what to expect upon landing.



Landing

When it's time to land, fly a normal landing pattern and approach. Keep a few clicks of power on until you are over

the runway threshold. For your first few landings, plan to land slightly faster than stall speed and on the main wheels, as this is the easiest way to land your Extra. Later, with a little practice you will find you can make slow 3-point landings.

Have a ball! But always remember to think about your next move and plan each maneuver before you do it. Impulsively “jamming the sticks” without any thought is what gets most fliers in trouble rather than lack of flying skill.

OTHER KITS AVAILABLE FROM GREAT PLANES



Great Planes Ultimate Bipe

The Ultimate Biplane is among the most celebrated stunt planes ever. Great Planes captures the essence of this air show legend in a stylish, .40-size sport-scale kit. The wings feature a fully symmetrical airfoil. With plug-in struts and only four fasteners, you can quickly remove and reattach the wings right at the field. **GPMA0240**



Great Planes Cap 232

You want a model with enough muscle for any maneuver in the book. You *don't* want to undertake a massive project. The solution? The .40-size CAP 232! Fly it for spectacular Sunday fun or for glory in IMAC or MINIMAC events. It has unlimited aerobatic potential...and plenty of low-speed stability to keep new sport pilots in control. Interlocking, die-cut, all-wood parts ensure straight, strong assembly. Dual elevator pushrods keep linkages tight and precise and permit infinite adjustability of each elevator half. **GPMA0232**

TWO VIEW DRAWING
Use copies of this page to plan your trim scheme.

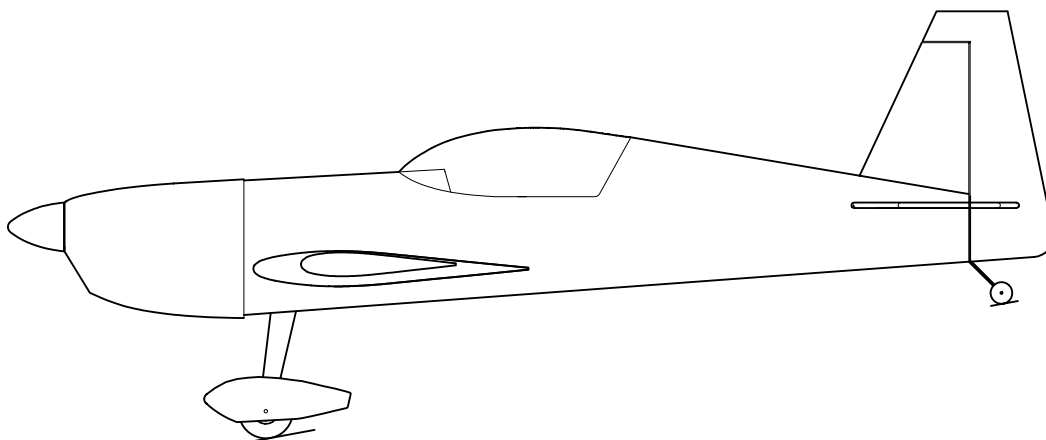
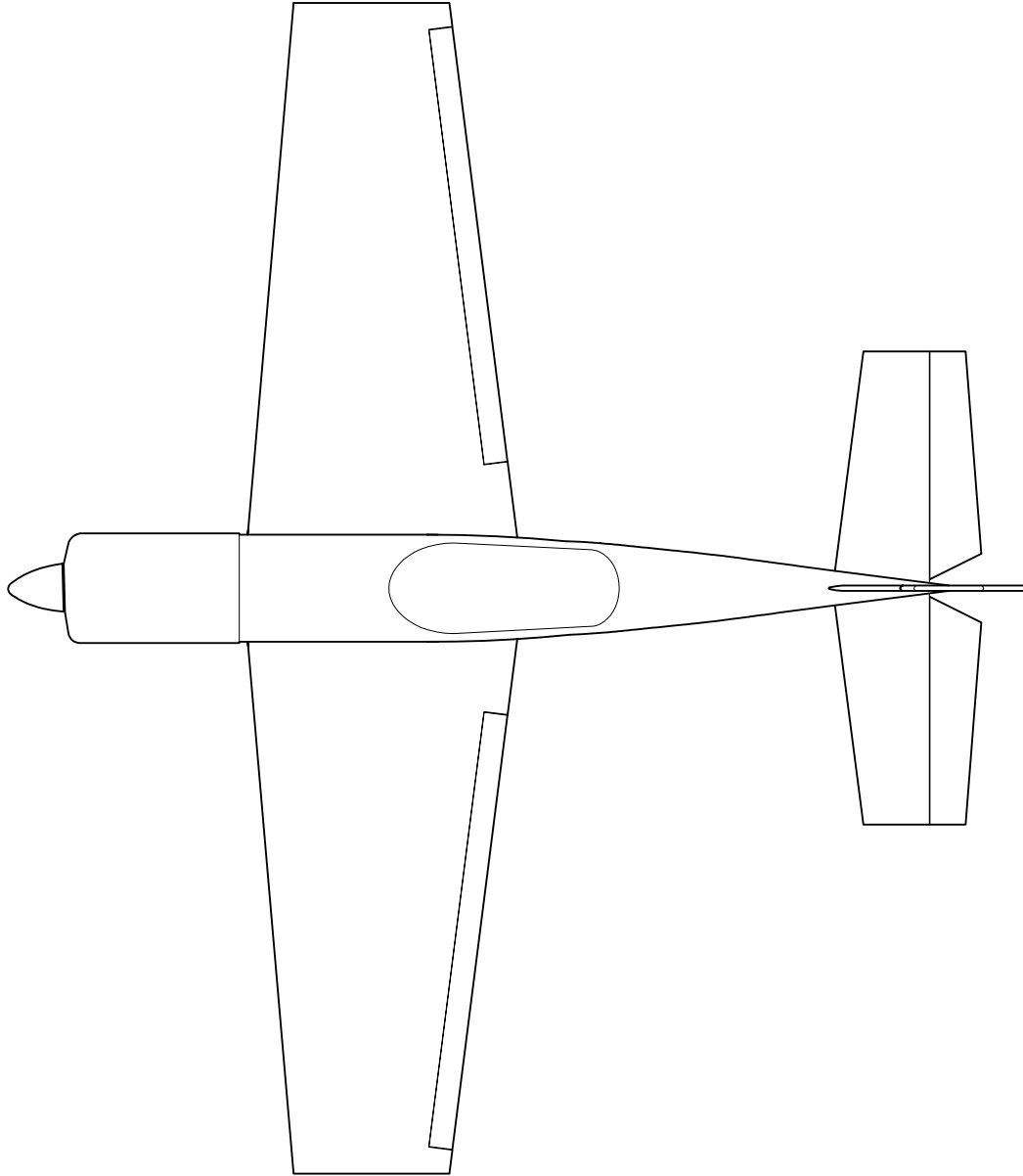

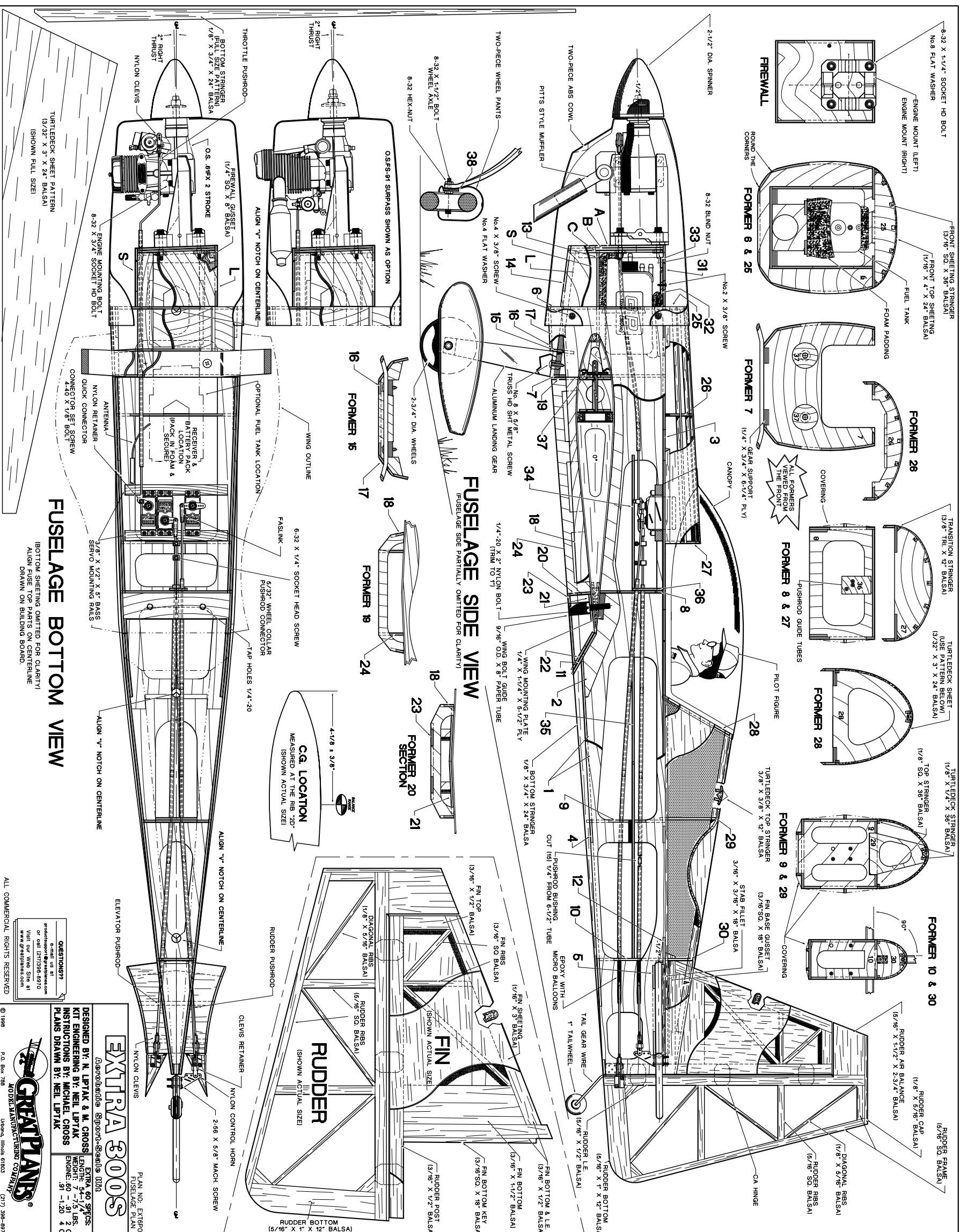

Extra 300S Parts List A
 Note: This parts list applies to the fuse plans only.

Part #	Part Name
1	Fuse Sides
2	Fuse Doubler
3	Forward Fuse Top
4	Aft Fuse Bottom
5	Stab Base
6	Fuse Former 6
7	Fuse Former 7
8	Fuse Former 8
9	Fuse Former 9
10	Fuse Former 10
11	Wing Saddle Fuse Former
12	Aft Fuse Top
13	Tank Floor
14	Firewall Box Bottom
15	Forward Gear Former
16	Forward Fuse Bottom
17	Bottom Corners
18	Belly Pan Sides
19	Forward Belly Pan Former
20	Middle Belly Pan Former
21	Wing Bolt Plate
22	Aft Belly Pan Former
23	Belly Pan Plate
24	Belly Pan Spines
25	Forward Front Deck Former
26	Middle Front Deck Former
27	Rear Front Deck Former
28	Backrest
29	Turtle Deck Middle Former
30	Turtle Deck Aft Former
31	Fuel Tank Hatch Part A
32	Fuel Tank Hatch Retainer
33	Fuel Tank Hatch Retainer
34	Forward Fuse Side Stringer
35	Aft Fuse Side Stringer
36	Pushrod Support
37	Dowel Rod Disks
A	Front Firewall Lamination
B	Middle Firewall Lamination
C	Aft Firewall Lamination
L	Firewall Box (Long Side)
S	Firewall Box (Short Side)

EXTRA 300S

DESIGNED BY: N. LPTAK & M. CROSS
 KIT ENGINEERING BY: NEIL LPTAK
 INSTRUCTIONS BY: MICHAEL CROSS
 PLANS DRAWN BY: NEIL LPTAK

PLAN NO: EXTPR02
 FUSELAGE PLAN

© 1998 P.O. Box 789 Urbana, Illinois 61803 (217) 398-8970

ALL COMMERCIAL RIGHTS RESERVED

Extra 300S Parts List B

Note: This parts list applies to the wing plans only.

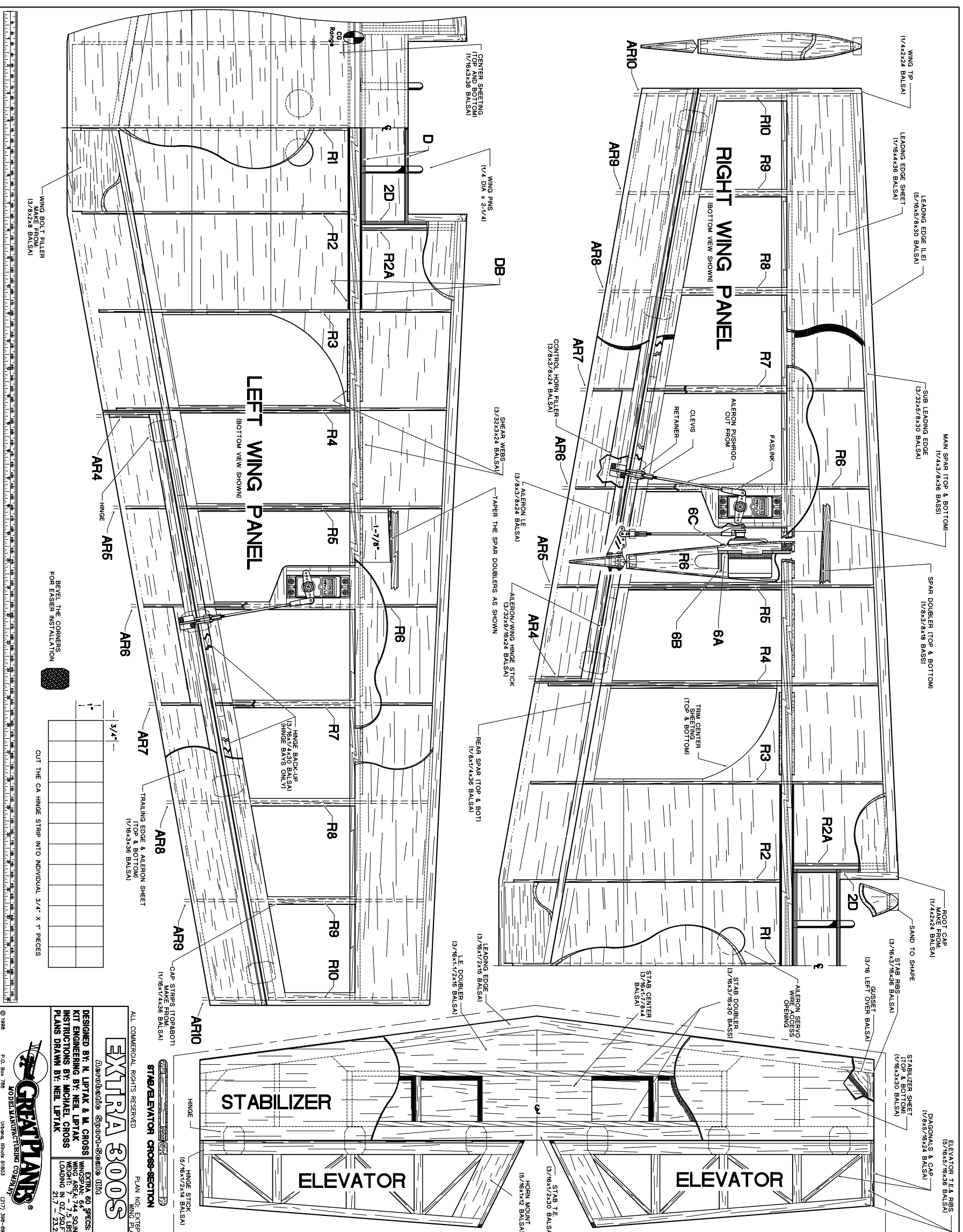

Part #	Part Name
R1	Rib #1 (Root Rib)
R2	Rib #2
R2A	Balsa Forward Sub Rib
R2D	Ply Forward Sub Rib
R3	Rib #3
R4	Rib #4
R5	Rib #5
R6	Rib #6
R7	Rib #7
R8	Rib #8
R9	Rib #9
R10	Rib #10 (Tip Rib)

6A	Aileron Servo Tray
6B	Servo Tray Support
6C	Balsa Sub Rib
AR4	Aileron Rib #4 (Root Rib)
AR5	Aileron Rib #5
AR6	Aileron Rib #6
AR7	Aileron Rib #7
AR8	Aileron Rib #8
AR9	Aileron Rib #9
AR10	Aileron Rib #10 (Tip Rib)

D	Dowel Plates
DB	Dihedral Braces
2D	Dowel Plates
AR10	Aileron Rib #10 (Tip Rib)

ALL COMMERCIAL RIGHTS RESERVED. PLAN NO. EXTP01 WING PLAN

EXTRA 300S

(Aerobondie Sporn-Steulle 003)

DESIGNED BY: N. LIPTAK & M. CROSS
 KIT ENGINEERING BY: NEIL LIPTAK
 INSTRUCTIONS BY: MICHAEL CROSS
 PLANS DRAWN BY: NEIL LIPTAK

EXTRA 60 SPECS:
 WING AREA: 54 SQ. FT.
 WEIGHT: 7 - 7.5 LBS.
 LANDING: 21" x 23"

© 1998
 P.O. Box 788
GREAT PLANS®
 MODEL AIRCRAFT SUPPLY COMPANY
 Ventura, Illinois 61083 (817) 306-8970