

P-51D MUSTANG

.40 Size

INSTRUCTION MANUAL

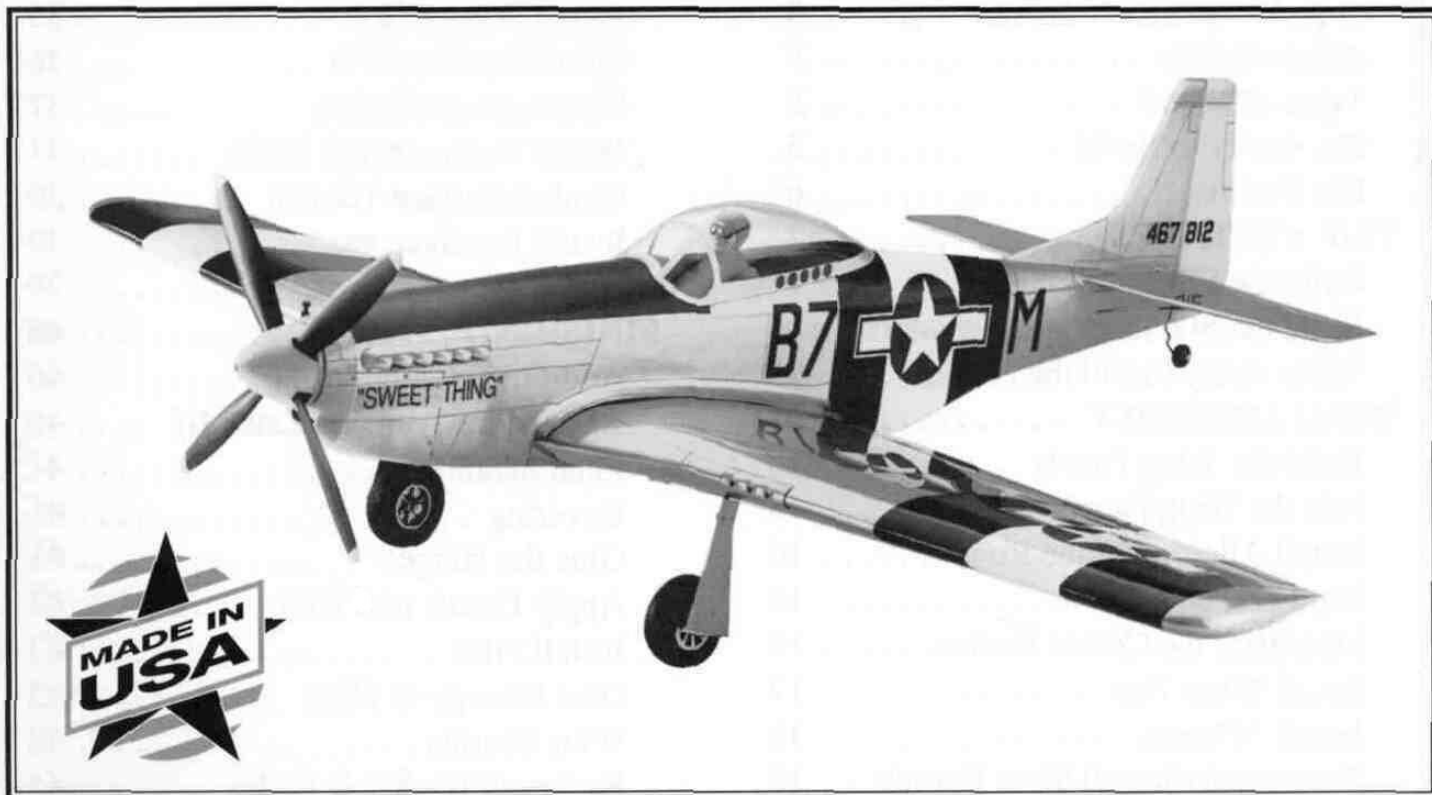

WARRANTY

Great Planes Model Manufacturing Co guarantees this kit to be free from defects in both material and workmanship at the date of purchase. This warranty does not cover any component parts damaged by use or modification. **In no case shall Great Planes' liability exceed the original cost of the purchased kit.** Further, Great Planes reserves the right to change or modify this warranty without notice.

In that Great Planes has no control over the final assembly or material used for final assembly, no liability shall be assumed nor accepted for any damage resulting from the use by the user of the final user-assembled product. By the act of using the user-assembled product, the user accepts all resulting liability.

If the buyers are not prepared to accept the liability associated with the use of this product, they are advised to return this kit immediately in new and unused condition to the place of purchase.

READ THROUGH THIS INSTRUCTION MANUAL FIRST. IT CONTAINS IMPORTANT INSTRUCTIONS AND WARNINGS CONCERNING THE ASSEMBLY AND USE OF THIS MODEL.



PO Box 788 Urbana IL 61801 (217) 398 8970
productsupport@greatplanes.com

TABLE OF CONTENTS

INTRODUCTION	3	Assemble Upper Cowl	33
Precautions	3	FINAL ASSEMBLY	34
Decisions You Must Make Now ...	4	Install Front Wing Fairing	34
Other Items Required	5	Assemble Air Scoop Front	34
Supplies and Tools Needed	5	Install Wing Fillets	35
Abbreviations	5	Mount Stab and Fin	36
Types of Wood	5	Shaping and Sanding	37
Get Ready to Build	5	Install Pushrods and Radio	37
Die Patterns	6	Control Surface Throws	39
TAIL FEATHERS	7	Install Receiver, etc.	39
Build the Fin and Rudder	7	Fit Cowl	39
Build the Stabilizer and Elevators ..	8	FINISHING	40
Temporarily Install the Hinges	9	Additional Fuelproofing	40
WING ASSEMBLY	9	Balance the Airplane Laterally	40
Build the Wing Panels	10	Final Sanding	41
Join the Wing Panels	15	Covering	41
Install Aileron Torque Rods	16	Glue the Hinges	41
Sand Flat on TE '	16	Apply Decals and Trim	42
Fiberglass the Center Section	16	Install Pilot	43
Install Wing Tips	17	Glue Canopy in Place	43
Install Ailerons	18	Wing Seating	43
Temporarily Install Wing Dowels ..	18	Re-install Engine & Radio	44
Install Wing Bolt Plate	19	Balance Your Model	44
Fill LG Slots	19	Final Hookups and Checks	44
Install Landing Gear Covers	19	PRE-FLIGHT	45
Install Retracts	20	Charge the Batteries	45
FUSELAGE ASSEMBLY	21	Find a Safe Place to Fly	45
Prepare Fuse Sides	21	Ground Check the Model	45
Prepare the Firewall	22	Range Check Your Radio	45
Assemble Lower Fuselage	23	Engine Safety Precautions	45
Drill Engine Mount	26	AMA Safety Code	46
Install Pushrod Guide Tubes	26	FLYING	46
Mount Wing to Fuse	27	CAUTION	47
Fit Fuel Tank and Fuelproofing	29	FLIGHT TRIMMING	47
Assemble Aft Deck	30	PARTS LIST	50
Assemble Front Deck	31	3-VIEW	52

WARNING! THIS IS NOT A TOY!

THIS IS NOT A BEGINNER'S AIRPLANE!

This R/C kit and the model you will build is not a toy! It is capable of serious bodily harm and property damage. **IT IS YOUR RESPONSIBILITY AND YOURS ALONE** -- to build this kit correctly, properly install all R/C components and flying gear (engine, tank, pushrods, etc.) and to test the model and fly it only with experienced, competent help, using common sense and in accordance with all safety standards as set down in the Academy of Model Aeronautics Safety Code. It is suggested that you join the AMA and become properly insured before you attempt to fly this model. **IF YOU ARE JUST STARTING R/C MODELING, CONSULT YOUR LOCAL HOBBY SHOP OR WRITE TO THE ACADEMY OF MODEL AERONAUTICS TO FIND AN EXPERIENCED INSTRUCTOR IN YOUR AREA.**

Academy of Model Aeronautics
5151 East Memorial Drive
Muncie, IN 47302-9252 (800) 435-9262

INTRODUCTION

Congratulations! Thank you for purchasing the **Great Planes P-51D Mustang!**

The Great Planes P-51D Mustang is a semi-scale (approximately 1/8-scale) model of the full-size North American P-51D. The prototype as pictured on the box cover is not a copy of any one full-size airplane in particular. Rather, we selected several typical trim features from several aircraft, making a good-looking and rather "generic" trim scheme that typifies the Mustang we all know.

Several full-size P-51 D Mustangs are shown on the box side panel to give you an idea of the many trim variations that have been used. If you are interested in sport scale competition, or just want to copy a specific full-size trim scheme, you'll be happy to know that color photos of these and MANY other P-51D Mustangs are available from: Scale Model Research, 2334 Ticonderoga Way, Costa Mesa, CA 92626.

Unlike many other scale models, the Great Planes P-51D Mustang is easy to build and fly, predictable, highly aerobatic, and has no "bad habits," making it a great sport-scale airplane (as long as you don't get carried away with paint and additions, making it a "lead sled")!. This model is designed to be a great flying "sport airplane," one that you feel comfortable with, flight after flight. It is not intended for scale competition, but with a little extra work it should place well in sport scale competitions at the local level.

This is not a beginner's airplane! While the P-51D is easy to build and flies great, we must discourage you from selecting this kit as your first R/C airplane. It is fast, highly maneuverable, and lacks the self-recovery characteristics of a good basic trainer such as the Great Planes PT Series airplanes. On the other hand, if you have already learned the basics of R/C flying and you are able to safely handle an "aileron trainer" airplane such as the Great Planes Trainer Series or Big Stick Series airplanes, the P-51 D is an excellent choice.

Please inspect all parts carefully before starting to build! If any parts are missing, broken or defective, or if you have any questions about building or flying this airplane, please call us at (217) 398-8970 and we'll be glad to help. If you are calling for replacement parts, please look up the part numbers and the kit identification number (stamped on the end of the carton) and have them ready when calling.

PRECAUTIONS

1. You must build the plane according to the plans and instructions. Do not alter or modify the model, as doing so may result in an unsafe or unflyable model. In a few cases the plans and instructions may differ slightly from the photos. In those instances you should assume the plans and written instructions are correct.
2. You must take time to **build** straight, true and strong.
3. You must use a proper R/C radio that is in first class condition, the correct sized engine and correct components (fuel tank, wheels, etc.) throughout your building process.

4. You must properly install all R/C and other components so that the model operates properly on the ground and in the air.
5. You must test the operation of the model before the first and each successive flight to insure that all equipment is operating, and you must make certain that the model has remained structurally sound. Be sure to check the nylon clevises often, and replace if they show signs of wear.
6. You must fly the model only with the competent help of a well experienced R/C pilot if you are not already an experienced and knowledgeable R/C pilot at this time.

Note: We, as the kit manufacturer, can provide you with a top quality kit and great instructions, but ultimately the quality and flyability of your finished model depends on how you build it; therefore, we cannot in any way guarantee the performance of your completed model, and no representations are expressed or implied as to the performance or safety of your completed model.

Remember: Take your time and follow directions to end up with a well-built model that is straight and true.

DECISIONS YOU MUST MAKE NOW

ENGINE AND MOUNT SELECTION

The recommended engine size range is as follows:

- .40* - .46 cubic inch displacement 2-cycle
- .60** - .70 cubic inch displacement 4-cycle

*NOTE: Performance may be marginal if a non-schneurle-ported .40 cu.in. 2-Cycle engine is used.

**NOTE: The O.S. Max 48 Surpass also provides sufficient power to fly this airplane.

NOTE: If you choose to side mount a 2-Cycle engine, we recommend using a muffler that can be almost completely enclosed inside the cowl. The muffler used in one of our prototypes is a Tatone #11413 Pitts Style Muffler for .29 - .40 engines. The muffler may require slight modification to fit your engine.

If you mount a 2-Cycle engine inverted or upright, a standard muffler may be used. Complete enclosure of the engine and exhaust requires inverted installation and a custom-made exhaust manifold.

The engine you select will determine how you build the fuselage, so it is important that you have the engine close at hand while building.

This kit includes the new Great Planes Adjustable Engine mount. This mount will work on most .40-.60 2-Cycles and .40-.70 4-cycles. Cut or break the "spreader bar" off each mount half. Carefully trim any extra plastic off each mount half left by the spreader bar. The surfaces where the spreader bars were attached need to be very smooth to allow the mount halves to fit together.

Snap the two mount halves together. Slide the mount halves apart until the engine mounting lugs will sit flat on the beams. Adjust the mount until the firewall centerline (or offset line) is centered between the "tick" marks on the mount.

NOTE: If you choose to power your P-51D with a 4-cycle engine, keep in mind that the RPM of your engine will be considerably less than that of a 2-Cycle engine; therefore, you should select a higher pitch propeller to keep the speed and overall performance roughly equivalent to that of a 2-Cycle engine. For example, a 10x6 or 10x7 prop would be used with a .40 (2-Cycle) engine; but a 12x8, 11x9 or 10x10 prop may be the best choices for a 4-cycle engine. The 4-blade prop shown on the prototype is a mock-up for static display purposes only.

SELECTION OF WHEELS

To save weight, we recommend using lightweight foam rubber wheels.

2-1/2" diameter main wheels are recommended for retracts (but 2-3/4" wheels will fit, and may be needed for satisfactory operation on grass fields).

2-3/4" diameter main wheels are recommended for normal sport flying with fixed landing gear (3" wheels may be needed for satisfactory operation on rough grass fields).

3-1/4" scale wheels may be installed for maximum scale realism (such as Robart UX-325 diamond-tread scale wheels).

A 1" diameter tailwheel is recommended.

OTHER ITEMS REQUIRED

- 0 Four-channel radio with 4 servos (additional channel and retract servo required if retracts are being used).
- 0 Propellers (see engine instructions and above engine notes for recommended sizes).
- 0 Spinner (2-3/4" diameter)
- 0 Fuel Tank (10 ounce)
- 0 5/32" Wheel Collars - 4
- 0 3/32" Wheel Collars - 2
- 0 Iron-on Covering Material
- 0 Fuelproof Paint* for Cowl, Canopy, Exhaust Ports & Cannons
- 0 Silicone Fuel Tubing
- 0 Wing Seating Tape (or silicone sealer ... see instructions)
- 0 Latex Foam Rubber Padding (1/4" thick)
- 0 Dubro "E-Z Connector" (optional)
- 0 Plastic Pilot: Williams Bros. "Standard, 2" Scale #176" (WWII Military Style)
- 0 Main Gear Retracts: (optional)
 - Mechanical: Dave Brown 2-Gear Main, B&D 85-degree mechanical retracts, or equivalent.
 - Pneumatic: Robart #606 85-degree mains, or equivalent (requires #188 air control kit)

*Note: Chevron "Perfect Paint" matches Super Monokote, and is available in convenient spray cans.

COMMON ABBREVIATIONS USED IN THIS BOOK AND ON THE PLANS:

Elev = Elevator
Fuse = Fuselage
LE = Leading Edge (front)
LG = Landing Gear
Lt = Left
Ply = Plywood
Rt = Right
Stab = Stabilizer
TE = Trailing Edge (rear)
" = Inches

TYPES OF WOOD



SUPPLIES AND TOOLS NEEDED

- 0 2 oz. Thin CA Adhesive
- 0 2 oz. Medium or Thick CA Adhesive
- 0 2.5 oz. 5-Minute Epoxy
- 0 2.5 oz. 30-Minute Epoxy
- 0 Hand or Electric Drill
- 0 Drill Bits: 1/16", 5/64", 3/32", 7/64", 1/8", 9/64", 5/32", 3/16", 13/64", 7/32", and 1/4"
- 0 Sealing Iron
- 0 Heat Gun
- 0 Hobby Saw (Xacto Razor Saw)
- 0 Xacto Knife, #11 Blades
- 0 Pliers
- 0 Screw Drivers
- 0 T-Pins
- 0 Straightedge
- 0 Masking Tape (Required for construction)
- 0 Sandpaper (coarse, medium, fine grit)*
- 0 T-Bar Sanding Block (or similar)
- 0 Waxed Paper
- 0 Lightweight Balsa Filler
- 0 1/4-20 Tap, Tap Wrench
- 0 Vaseline Petroleum Jelly
- 0 Isopropyl Rubbing Alcohol (70%)
- 0 3M "77" Spray Adhesive (optional)
- 0 Dremel Moto Tool or similar (optional)

*NOTE: On our workbench, we have four 11" T-Bar sanders, equipped with #50, #80, #100 and #150-grit sandpaper. This setup is all that is required for almost any sanding task. We also keep some #320-grit wet-or-dry sandpaper handy for finish sanding before covering.

GET READY TO BUILD

D 1. Unroll the plan sheets. Re-roll the plans inside out to make them lie flat.

D 2. Remove all parts from the box. As you do, figure out the name of each part by comparing it with the plans and the parts list at the back of this book. Using a felt tip pen, write the part **name** or **size** on each piece to avoid confusion later. Use the die-cut patterns shown on page 6 to identify the die-cut parts and mark them **before** punching out. Save all scraps. If any of the die-cut parts are difficult to punch out, do not force them! Instead, first cut around the parts with an Xacto knife. After punching out the die-cut parts, use your T-Bar or sanding block to **lightly** sand the edges to remove any die-cutting irregularities.

D 3. As you identify and mark the parts, separate them into groups, such as **fuse** (fuselage), **wing**, **fin** and **stab** (stabilizer), and **hardware**.

DIE PATTERNS

P540F05

2 PER KIT

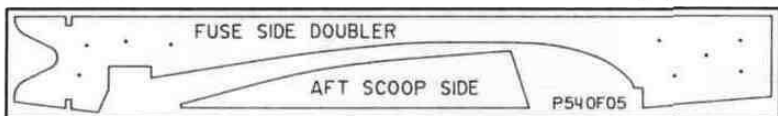

BALSA 1/8" x 3" x 21"

P540F07

1 PER KIT

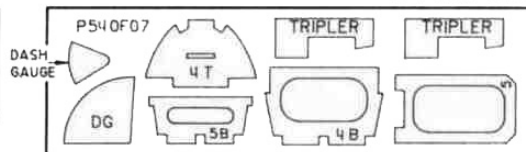

PLY 1/8" x 4-1/4" x 13-3/8"

P540F09

1 PER KIT

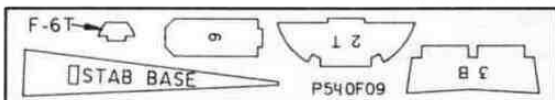

BALSA 1/8" x 2-5/8" x 14-7/8"

P540F19

1 PER KIT

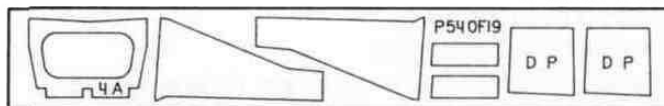

PLY 1/8" x 2-3/4" x 18"

P540F10

1 PER KIT

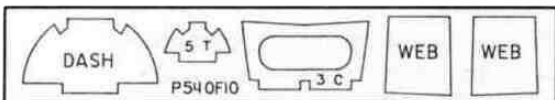

BALSA 1/8" x 2-5/8" x 14-7/8"

P540W05

2 PER KIT

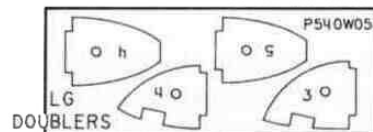

PLY 1/16" x 3-1/2" x 9-3/8"

P540F03

1 PER KIT

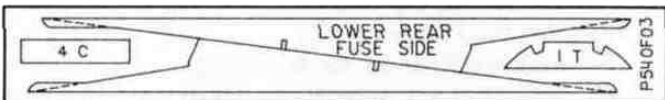

BALSA 1/8" x 2-5/8" x 18"

P540W06

1 PER KIT



PLY 1/16" x 3-1/2" x 9-3/8"

P540W01

2 PER KIT

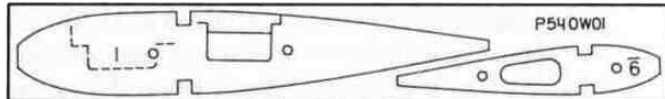

BALSA 3/32" x 2-5/8" x 18"

P540W06

1 PER KIT



PLY 1/16" x 3-1/2" x 9-3/8"

P540F08

1 PER KIT

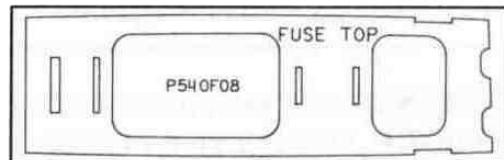

PLY 1/8" x 4-1/4" x 13-3/8"

P540W02

2 PER KIT



BALSA 3/32" x 2-5/8" x 15"

P540F06

1 PER KIT

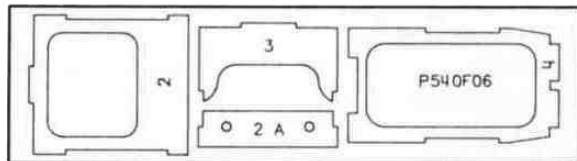

PLY 1/8" x 4-1/4" x 15-1/2"

P540W03

2 PER KIT

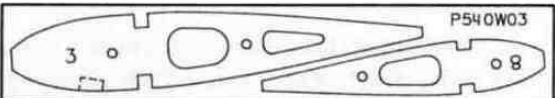

BALSA 3/32" x 2-5/8" x 15"

P540F04

2 PER KIT

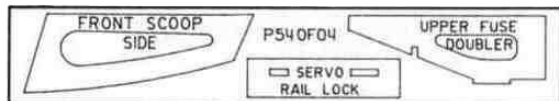

BALSA 1/8" x 2-5/8" x 14-7/8"

P540W04

2 PER KIT

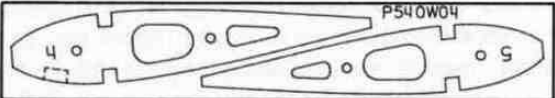

BALSA 3/32" x 2-5/8" x 15"

P540F02

2 PER KIT

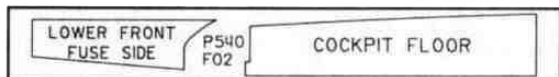

BALSA 1/8" x 2" x 14-7/8"

P540W24

2 PER KIT

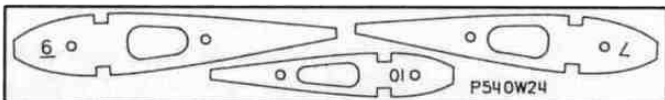

BALSA 3/32" x 2-5/8" x 18"

TAIL FEATHERS

BUILD THE FIN AND RUDDER

To build the fin and rudder you'll need the following:

- 1/4" shaped balsa **fin front**
- 1/4" shaped balsa **fin rear**
- 1/4" shaped balsa **rudder rear**
- 1/4" x 1-1/4" x 9-1/2" balsa sheet
- 1/4" x 1/4" x 30" balsa stick

D 1. Tape the **fuselage plan** down to your flat work surface. Tape a piece of waxed paper over the fin and rudder portion of the plan.

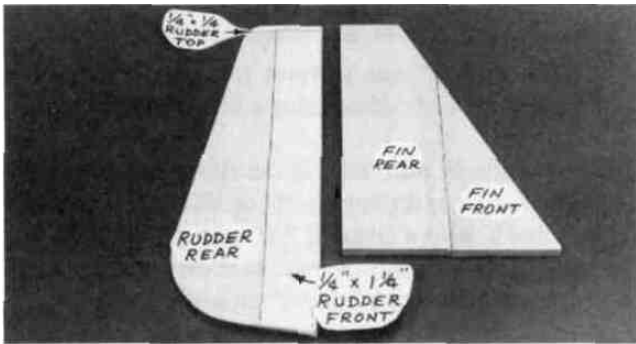

D 2. Working on a flat surface covered with waxed paper, glue the **fin front** to the **fin rear**.

D 3. Using a T-bar or sanding block, sand both sides of the fin smooth, then sand the outline of the fin to match the plan.

D 4. Using the plan as a guide, glue the 1/4" x 1-1/4" x 9-1/2" balsa **rudder front** to the shaped balsa **rudder rear**, lining up the top edges.

D 5. Cut a 2-1/4" length of 1/4" x 1/4" balsa, and glue it to the top of the rudder.

D 6. Trim the edges of the rudder to match the plan, then use your T-bar with medium grit sandpaper to sand both sides of the rudder smooth.

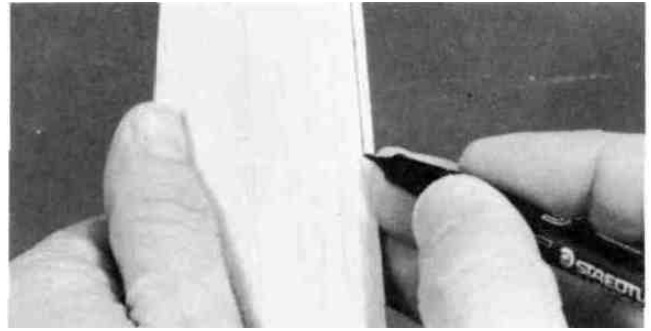

D 7. Carefully draw a **centerline** all around the edges of the fin and rudder (this will help to maintain symmetry when sanding).

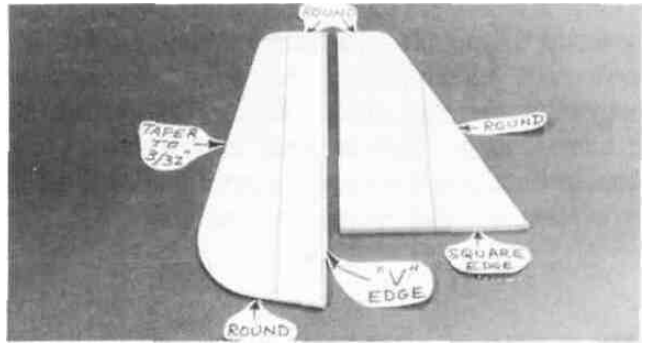

D 8. Using a sanding block and **coarse** (50 or 80-grit) sandpaper, sand both sides of the rudder to a **taper** as shown on the plans. The trailing edge should end up approximately 3/32" wide and have a rounded shape. (Do not sand to a sharp edge). Sand the bottom edge to a rounded shape. Sand the leading edge to a "**V-shape**" as shown on the plan. Sand the **top** and front edges of the fin to a rounded shape.

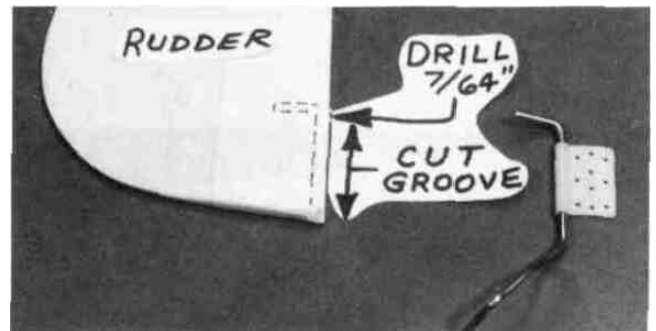

D 9. Check the plans and mark the location of the tailgear* on the rudder. Drill a 7/64" hole in the rudder (the hole is drilled slightly oversize to allow for positioning, and to create a hard epoxy "sleeve" around the wire). Then groove the rudder leading edge to accept the tailgear wire. (See the photo at step 5 on page 18).

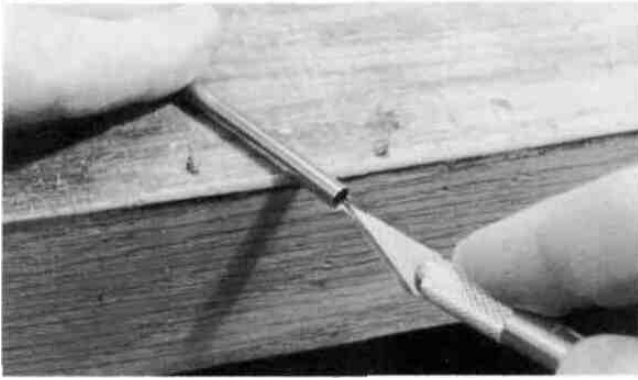

HINT: Using an Xacto knife, sharpen the inside of one end of a 1/8" diameter brass tube, and use it to cut the groove in the leading edge of the rudder.

***NOTE:** The tailwheel location and installation shown on the plan is designed for easy installation and durability, and for the best possible ground handling characteristics. However, if you are building your P-51 for sport scale competition, you may want to install a tailgear (fixed or retractable) in the "scale location" shown on the plan. These instructions do not cover such a modification, but the location is shown for your convenience.

BUILD THE STABILIZER AND ELEVATORS

To build the stab and elevators you'll need the following:

- 1/4" shaped balsa stab front
- 1/4" shaped balsa stab rear
- 1/4" shaped balsa elevators
- 1/8" bent wire elevator joiner

D 1. Glue the stab front to the stab rear. Sand the outline of the stab to match the plan, then sand both sides of the stab smooth.

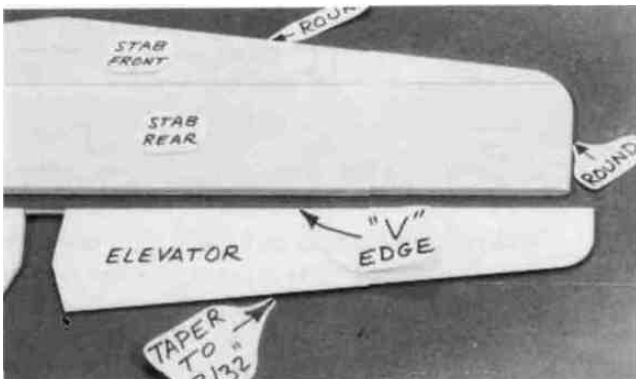

D 2. Sand the leading edge and ends to a **rounded** shape. (Leave the center portion of the LE **square**).

D 3. Check the shaped balsa elevators and sand if necessary to match the plan.

D 4. Draw a centerline all around the edges of the stab and elevators.

D 5. Sand both sides of the elevators to a taper as shown on the plans. The trailing edge should end up approximately 3/32" wide and have a rounded shape (do not sand to a sharp edge). Sand the leading edge to a "V-shape" as shown on the plan.

D 6. Temporarily tape the elevators to the stab.

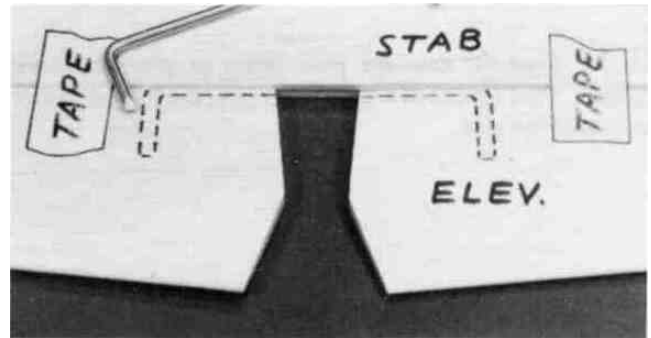

D 7. Lay the 1/8" wire elevator joiner in place on the elevators and mark its outline using a fine point felt-tip pen.

D 8. Accurately drill holes in the elevators for the 1/8" wire joiner. Begin by drilling a 1/16" or 5/64" pilot hole, then drill the final hole to a depth of 7/8" with a 9/64" drill bit. (The hole is drilled slightly oversize to allow for positioning, and to create a hard epoxy "sleeve" around the wire).

D 9. Using an Xacto knife, sharpen the inside of one end of a 1/8" diameter brass tube and use it to cut grooves in the leading edge of the elevators to accept the joiner wire.

D 10. Roughen the joiner wire with coarse sandpaper, then clean the wire thoroughly with alcohol to remove any oily residue.

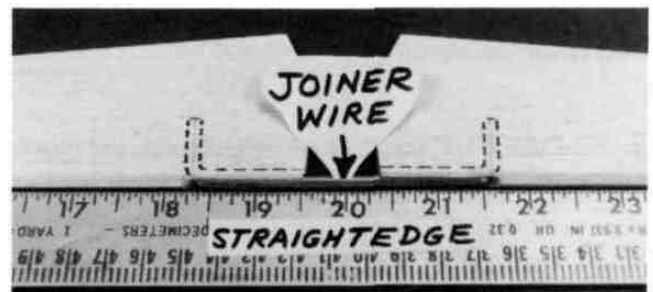

D 11. Trial fit the joiner wire into the elevators, then glue it in using 5-minute or 30-minute epoxy. Work plenty of

epoxy into the holes with a toothpick, then lay the elevator leading edges along a straightedge to insure perfect alignment.

TEMPORARILY INSTALL HINGES

(Do not glue)

NOTE: On an experimental basis, we have included "laminated hinges" in this kit, and the following instructions are written for this type of hinge. Our R&D department has thoroughly tested these hinges and found them to be easy to install and sufficiently strong and durable for this type of airplane. However, as the kit builder you are reminded that you are ultimately responsible for the structural integrity of your aircraft. If you are not confident using this type of hinge, please feel free to substitute your favorite hinge.

D 1. Lay the rudder and elevators on the plan and mark the hinge locations. Place the rudder against the fin TE and transfer the marks over to the fin. Place the elevators against the stab TE and transfer the marks over to the stab.

CAUTION!!!: You must use extreme care when cutting hinge slots with an Xacto knife, to avoid cutting yourself! If the balsa part breaks while you are pushing on the knife, the blade could go into your hand before you know it! A good precaution is to wear leather gloves while performing the following steps.

D 2. Cut the hinge slots on the accurate centerlines which you previously drew, using an Xacto knife. The recommended procedure for cutting hinge slots with an Xacto knife is given below.

A. Begin by carefully cutting a very shallow slit in the trailing edge at the hinge location. This first cut is to establish your cut in the right place, so concentrate on staying on the centerline and don't cut too deep!

B. Make three or four more cuts in the same line, going slightly deeper each time. As you make these additional cuts, work on going straight into the wood. Continue this process while "wiggling" the knife handle back and forth until the blade has reached the proper depth for the hinge.

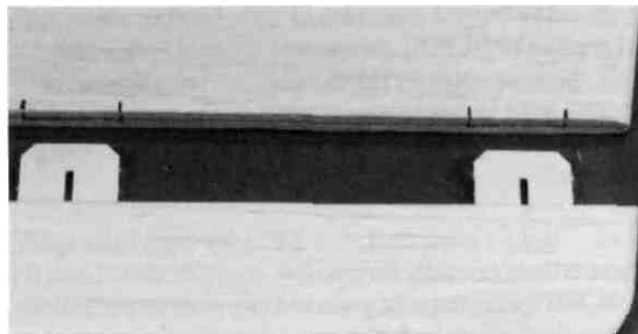
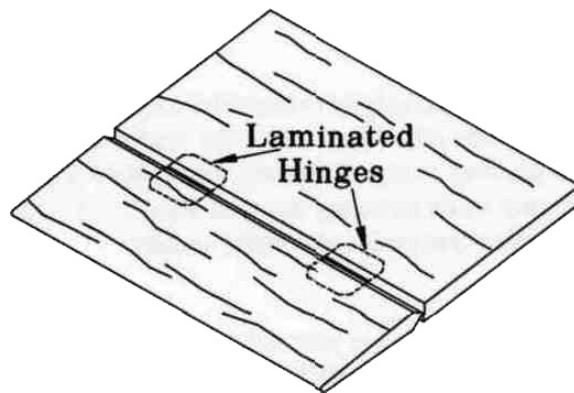

C. Trial fit the hinge into the slot. If the hinge is difficult to push in, re-insert the knife and move it back and forth in the slot a few times to enlarge the slot.

D 3. Insert the hinges into the slots and trial fit the rudder and elevators in place on the fin and stab. Do not glue the hinges until you are instructed to do so later in this book. Hinge gluing instructions are included later.

WING

NOTE: The following instructions explain how to build the wing on a flat surface, directly on the plans. An alternate method is to use a Great Planes Wing Jig (available from your local hobby dealer). Many expert modelers prefer to use a wing jig for high performance airplanes, as it helps to insure a straight, warp-free wing, especially if you do not have a workbench or building board that is perfectly flat. If you choose to use the Wing Jig, please read the instructions that are included with the jig before beginning.

BUILD THE WING PANELS

NOTE: It will be helpful to build the wing on a piece of "Celotex"* or other semi-soft (and flat) surface, into which you may easily stick pins to firmly hold down the wing parts while building, to avoid warps. *Available from lumber companies and home centers.

D 1. Tape the plan to your flat work surface, and cover the wing drawing with waxed paper (so you won't glue the wing to the plan!). **NOTE:** If your work space is limited, you may cut the left and right wing half drawings apart.

D 2. The shaped and notched wing leading edges (LE) and trailing edges (TE) are fastened together by thin strips of balsa. Separate them by folding until the balsa breaks, or by cutting. Sand away the excess balsa that remains along the edges after breaking them apart, using a T-bar with 100-grit sandpaper.

D 3. Before using the 1/4" x 3/8" x 28" hard balsa spars, examine them carefully for possible imperfections. Look for knots, soft spots, diagonal grain and any other imperfections. If possible, position each spar so the imperfections (if any) are on the outer half of the wing panel (toward the tip), where they will be least affected by high stress. If the spars are warped slightly, try to "balance them out" by installing the warped spars in opposite directions (see sketch). **NOTICE:** If you feel that any of the wing parts are unusable due to severe warps or other defects, give us a call and we'll replace the parts.

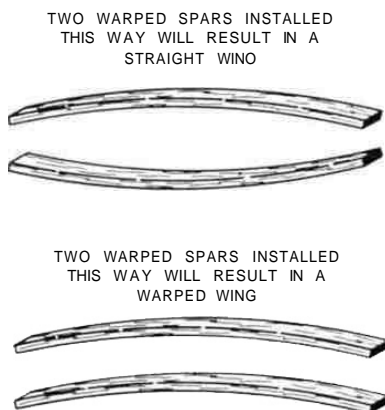

D 4. Find the four 1/8" x 3/8" x 13" hard balsa spar doublers. Sand one end of each spar doubler to a taper as shown in the "Wing Spar Detail" on the plan. Glue the spar doublers to the spars, and sand off any excess glue.

D 5. Carefully punch out all the die-cut 3/32" balsa wing ribs. Sand the edges slightly to remove any die-cutting irregularities.

NOTE: If you will be installing a retractable landing gear, disregard Step 6.

D 6. Note that the wing plan shows the location of the main landing gear blocks. Note also that Ribs W-3 and W-4 have partial cutouts for the grooved landing gear block. If you are building your plane with a fixed (not retractable) landing gear, finish cutting out the notches in these ribs. (If you will be installing retracts, do not cut out these notches).

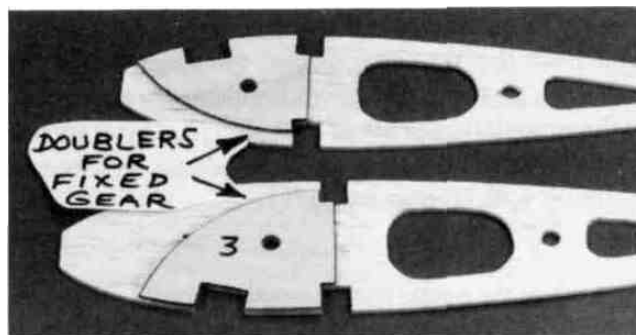

D 7. Glue the die-cut 1/16" ply notched landing gear doublers to ribs W-3 and W-4 (for fixed gear only). If installing retracts, you will later glue the other set of 1/16" ply "nose rib doublers" to ribs W-4 and W-5. Be sure to glue them to the correct side of the ribs, as shown on the plan (make a right and a left set). Sand the doublers even with the edge of the ribs.

D 8. Prepare the leading edge sheeting by trimming the 3/32" x 2-7/8" x 28" balsa sheets as shown in the following sketch.

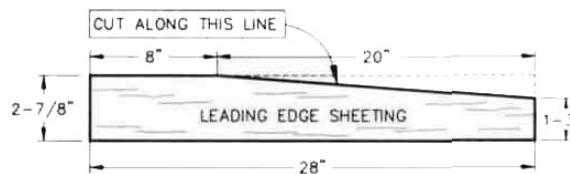

NOTE: Follow steps 9 through 36 to build the **RIGHT** wing panel, then repeat these steps to build the **LEFT** wing panel.

DD 9. Pin one of the spars to the plan with the spar doubler up and toward the root. **NOTE:** The spars are cut

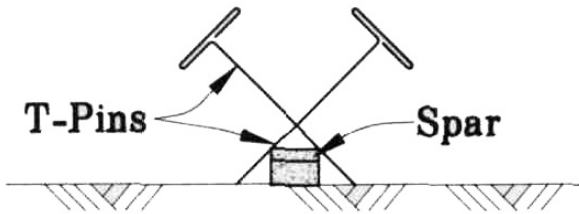

slightly too long. Center the spar on the plan so an equal amount protrudes on both ends.

DD 10. Place the ribs on the spar in their approximate position, but do not glue. NOTE: Make sure ribs W-3 and W-4 are installed with the LG notches down, and W-1 is installed with the servo opening pointing up.

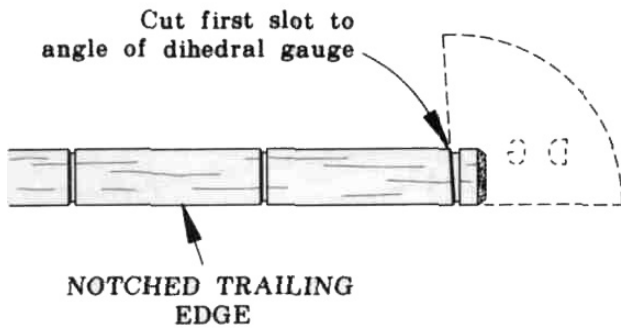

DD 11. Examine the shaped, notched balsa trailing edges. Notice that the notches at one end of each TE are only 1-7/8" apart. These are the notches for W-1 and W-2. Also notice that all notches in the TE are vertical; however, rib W-1 will be installed at a slight angle using the Dihedral Gauge. Therefore, you should now modify the notch for W-1 by cutting it to the angle of the rib. You may determine the approximate angle of the cut by holding the Dihedral Gauge (DG) against the TE as shown above.



DD 12. Examine the shaped, notched balsa leading edges. Notice that one end does not have notches, this is the root end. Use a razor saw to cut notches in the leading edge as shown in the "Leading Edge Detail" on the wing plan. These notches will aid in "breaking" the leading edge in the correct locations.

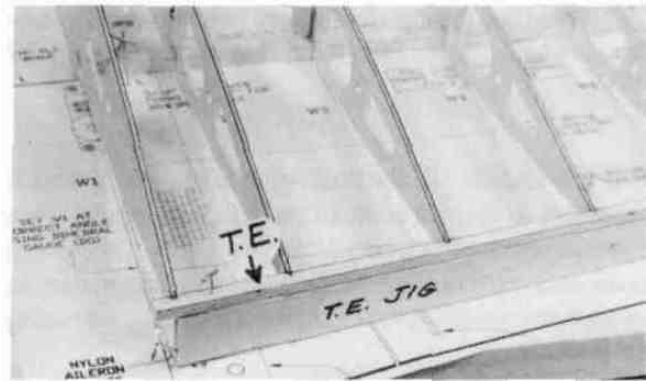

DD 13. Insert the rear ends of the ribs into the notches in the TE, then block up the TE with the 1/4" balsa TE Jig supplied. NOTE: The narrow end of the TE jig is at rib W-11. Pin the jig to the building surface.

DD 14. Pin the TE to the TE Jig, making sure the ribs line up with the plan.

DD 15. Glue ribs W-2 through W-11 to the TE. (Apply glue sparingly, to avoid gluing the TE to the TE Jig).

DD 16. Bend (break) the leading edge at the notches which you previously cut, then insert the front ends of the ribs into the notches in the LE. NOTE: Position the LE as shown here

CENTER L.E. VERTICALLY ON FRONT OF RIBS

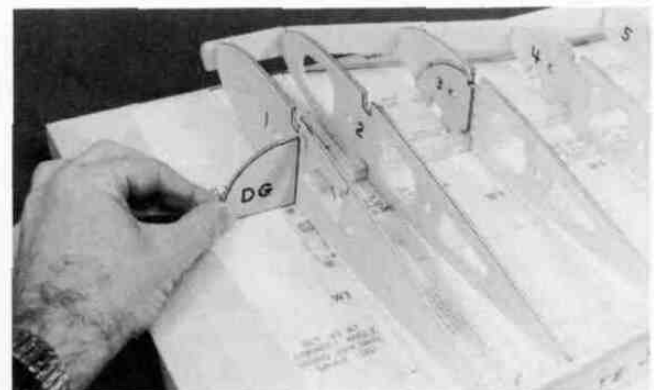
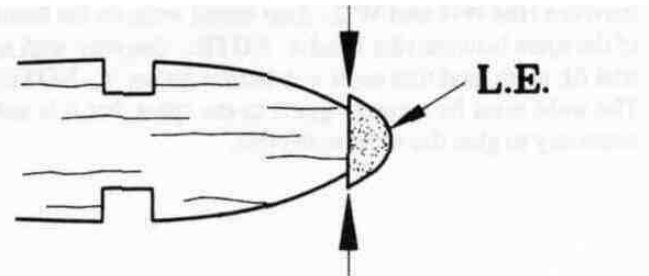

DD 17. Make sure the ribs are fully down on the plan and ribs 5 -11 are inserted into the LE notches. Glue ribs 2-11 to the LE and bottom spar. Angle rib W-1 slightly using the dihedral gauge (DG). Glue W-1 to the TE, LE and bottom spar. NOTE: Thin CA glue may be used in tight-fitting joints, but to insure strong joints we recommend that you follow up by also applying medium or thick CA to all joints.

DD 18. Glue the top spar in place (with the spar doubler facing down), making sure you do not change the angle of W-1.

IMPORTANT: In the following steps you'll find it necessary to remove some of the pins holding the wing down to your building board. As you do, take other steps as necessary to continue holding the wing down, such as by applying weight to the top of the wing, or by relocating the pins.

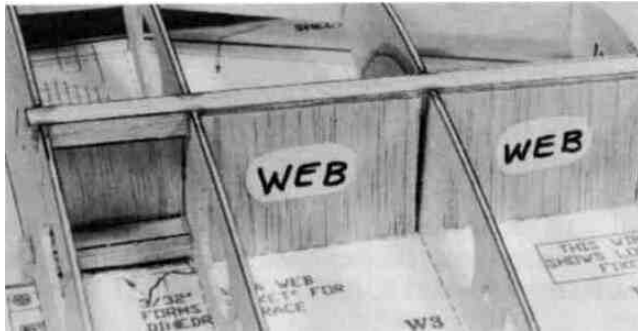

DD 19. Glue the pre-cut 3/32" balsa vertical grain shear webs to the rear edge of the spars in all rib bays except between ribs W-1 and W-2. Also install webs on the front of the spars between ribs 1 and 4. NOTE: You may wish to trial fit, mark, and trim each web before gluing in. NOTE: The webs must be securely glued to the spars, but it is not necessary to glue the webs to the ribs.

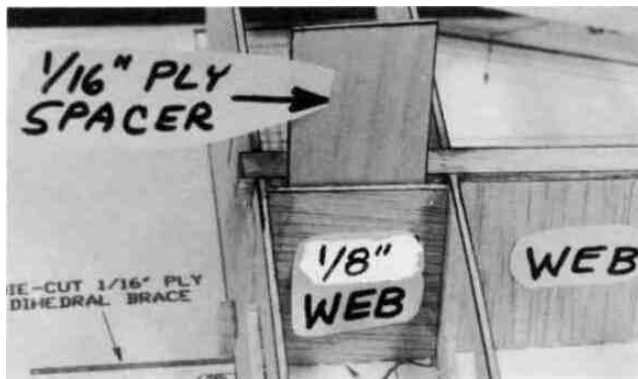

DD 20. You will now make a "pocket" for the 1/16" ply dihedral brace by installing a 1/8" die-cut balsa (horizontal grain) web 1/16" behind the spars. The die-cut web is very close to the correct size, but sand it as necessary for a good fit between W-1 and W-2. Using a scrap of 1/16" ply as a temporary spacer, glue the 1/8" web to W-1 and W-2.

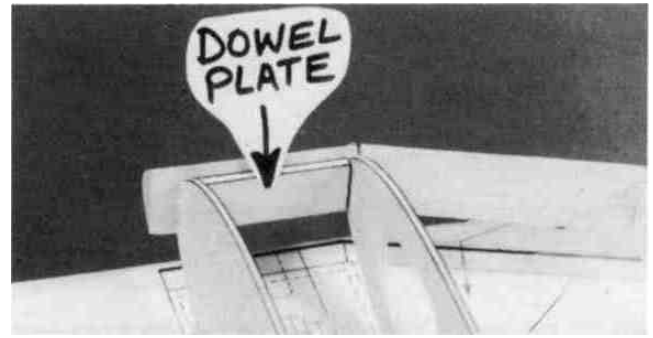

DD 21. Securely glue the die-cut 1/8" ply dowel plates into the wing. The small dowel plate glues to the back edge of the leading edge and to ribs W-1 and W-2. The large dowel plate is located 1" behind the small dowel plate, and is glued to ribs W-1 and W-2. NOTE: The photo shows only the small dowel plate.

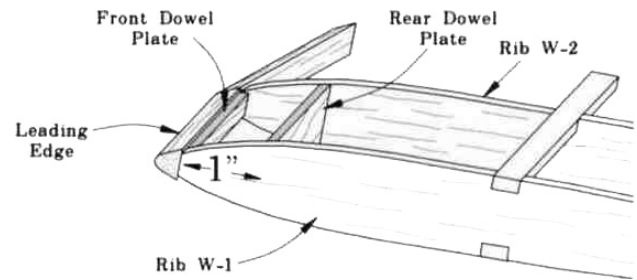

NOTE: In the next steps, maintain straightness by keeping the wing down on the flat surface and on the TF Jig.

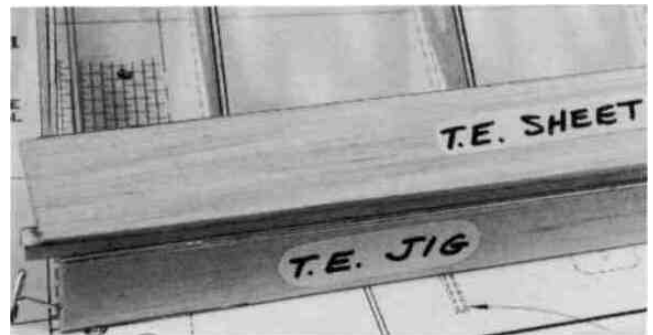

DD 22. Lightly sand the tops of the ribs to blend with the notched trailing edge; then glue one of the 3/32" x 1-3/8" x 28" balsa trailing edge sheets in place. NOTE: The edge of the TE sheet may not be exactly straight, but just position the sheet so it slightly overlaps the TE, and any overlap can be sanded off later.

DD 23. Before applying the leading edge sheeting in the next step, use your T-bar to lightly sand off the edges of the shear webs and smoothly blend the ribs to the spar.

DD 24. Prepare the 3/32" balsa leading edge sheeting by sanding the front edge to a slight bevel so it will fit snugly against the back of the leading edge (this is only done in the area from rib W-4 to the tip).

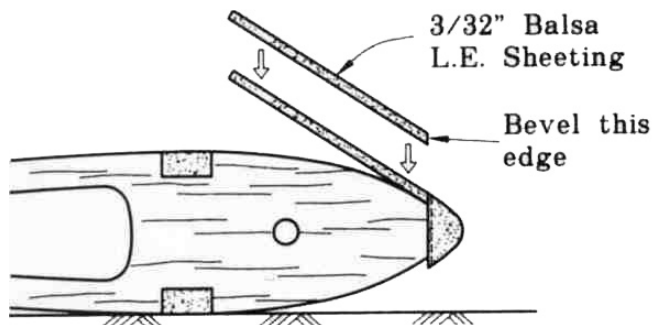

NOTE: It will be helpful to have the following items handy for the next step... thin CA, thick CA, a wet cloth and twelve 8-inch strips of masking tape. Read through the following step and go through a "dry run" before actually gluing.



DD 25. Apply thick CA glue to the top edge of the ribs and to the front half of the spar. Working quickly, position the leading edge sheeting at the rear edge of the notched LE so there is an equal amount protruding on both ends of the wing. Using thin CA, glue the front (beveled) edge of the leading edge sheeting to the back edge of the leading edge. Now wet the top surface of the sheeting so it will bend easier, then immediately bend the sheeting down onto the ribs and spar. Hold the sheeting down with long strips of masking tape until the glue has set.

DD 26. Using four of the 3/32" x 3" x 7-7/8" balsa sheets, cut pieces to complete the LE sheeting from W-1 to W-4, and glue in place. You'll have to wet this sheeting to permit

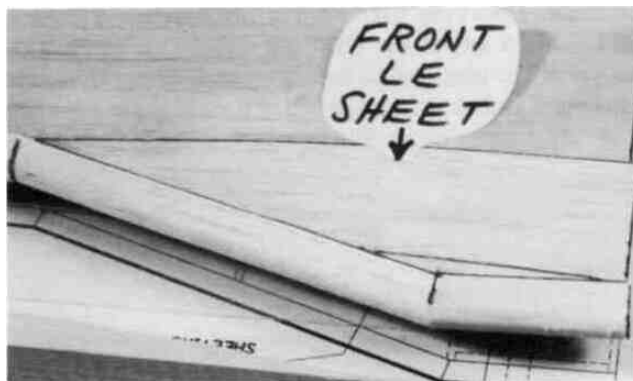

bending over the ribs. Any small gaps and irregularities may later be sanded or filled with balsa filler.

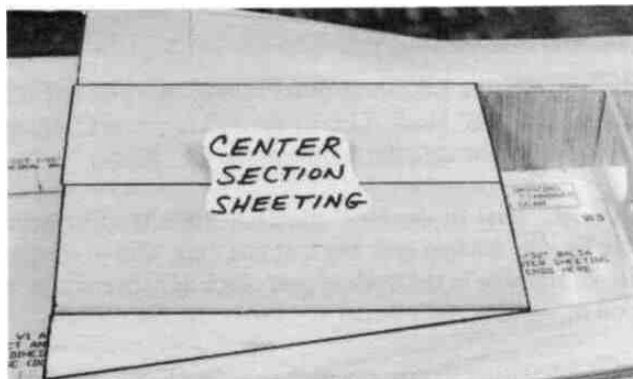

DD 27. Using the 3/32" x 3" x 7-7/8" balsa sheets and the scraps which you trimmed from the LE sheeting, glue the top center section sheeting in place as shown on the plan.

NOTE: If you are installing retracts, disregard steps 28 through 31.



DD 28. Remove the wing from the building board and trial fit the long grooved hardwood **LG block** into the notches in ribs W-3 and W-4 (see the landing gear detail drawing on the wing plan for proper positioning). File the notches if necessary for a good fit. Now use epoxy to securely glue the block in place.

DD 29. Epoxy the 7/16" x 5/8" x 7/8" hardwood block to the LG block and to the 1/16" ply doubler on rib W-3, as shown on the plan and in the photo, then epoxy the **small hardwood gusset** to the other end of the LG block and to the 1/16" ply doubler on rib W-4.

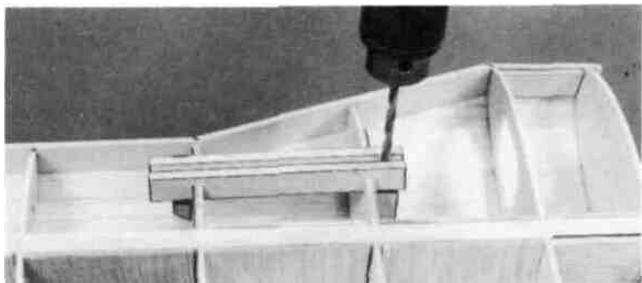

DD 30. Drill a 5/32" hole down through the grooved LG block and the 7/8" block. Line up the drill so you are drilling straight down through the middle of the 7/8" block.

DD 31. Trial fit the 5/32" diameter **main landing gear wire** into the landing gear block at this time. Cut or file the groove and hole in the landing gear block as necessary for a good fit.

DD 32. Using a razor saw and a sanding block, carefully cut off and sand all excess sheeting, spars, LE and TE even with W-1 and W-11.

NOTE: If you will be installing retracts, now is the time to install the 1/4" x 5/8" x 2-5/8" ply retract mounting rails with epoxy on the bottom of the wing between the 1/16" ply doublers on ribs W-4 and W-5, as shown on the plan. Add 1/4" balsa triangle under the 1/4" ply rails. Installing retracts requires careful planning and a lot of trial fitting, customizing the installation as necessary to accommodate your retracts; therefore, you should take the time now to plan out your installation. Here are some typical tasks you must perform when installing retracts:

NOTE: All photos in this book show installation of the Dave Brown mechanical retracts.

A. Glue in the 1/16" ply nose rib doublers to reinforce ribs W-4 and W-5 where retracts are to be installed.

B. Trial fit the retract unit to determine the mounting location and angles. Cut away the ribs as necessary for clearance.

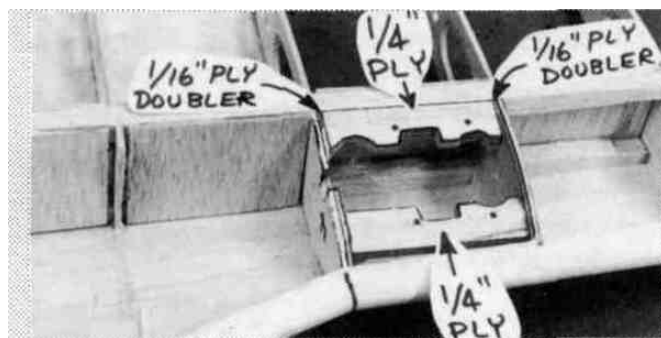

C. Glue in 1/4" ply retract mounting; rails using epoxy.

D. Trim the rails as necessary.

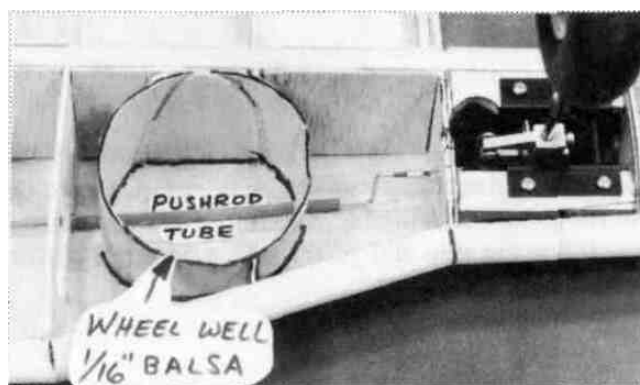

E. Install pushrod and guide tube just under the top sheeting.

F. Fabricate wheel well from 1/16** balsa or styro-foam cup.



G. Install retract unit and check operation.

H. Sheet bottom of wing, taking note where sheeting will be cut away for retract.

DD 33. With the wing upside down, again use the TE jig to support the TE. Then install the bottom TE sheeting, LE sheeting* and Center Section sheeting, cutting and fitting the

sheeting around the LG block as necessary. **IMPORTANT NOTE:** To insure a straight wing, you must pin or weight the TE securely down on the TE jig while the bottom sheeting is glued in place!

*As you apply the bottom LE sheeting, remember to mark the sheeting in the exact areas of the retract mechanism, LG wire, and wheel well locations, so you can easily find and trim the sheeting from these areas later.

(Retracts): Trim away the sheeting in the area of the retract and wheel well.

NOTE ON RETRACTS: Additional instructions and photos covering installation of retracts will be found at the end of the Wing section, on page 20.

DD 34. From the 3/32" x 1/4" x 30" balsa sticks, cut and glue cap strips to all exposed ribs, top and bottom. **HINT:** For easier positioning of the cap strips, first mark the location of each rib on the LE and TE sheeting.

DD 35. Trim the sheeting flush with ribs W-1 and W-11 and sand the entire wing panel smooth. Sand the leading edge to smoothly blend with the LE sheeting (see note below).

IMPORTANT: The shape of the leading edge will affect the way this airplane performs snap rolls and spins. A blunt, rounded leading edge will "soften" the stall, making the plane very docile when flying slowly, enabling it to flare nose-high for very slow landings; however, this may cause the plane to be a little sluggish when trying to enter a snap roll or spin. A sharper leading edge will help the plane enter snap roll and spin maneuvers more crisply, while sacrificing only a little of the low speed stability. The leading edge has been approximately pre-shaped, but we recommend that you cut out the **Leading Edge Template**, and use it as a guide when sanding the leading edge to final shape. **To avoid tip stalls, make sure the leading edges of both wing panels have the same shape.**

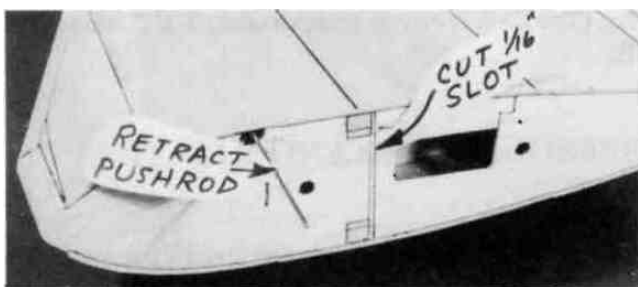

DD 36. Mark and cut out a 1/16" slot in W-1 just behind the spars, for the dihedral brace.

D 37. Now go back and repeat Steps 9 through 36 to build the left wing panel.

JOIN THE WING PANELS

NOTE: Read steps 1 through 4, then make a "dry run," practicing these steps before actually proceeding.

D 1. Lay a piece of waxed paper down and place the two wing panels, right side up, so that the W-1 ribs are together. Using wood scraps, make two blocks similar to that shown in the photo, and use them to block up both wing tips 1-5/8 inch. Sand the wing panels at the center so they will fit together without a gap.

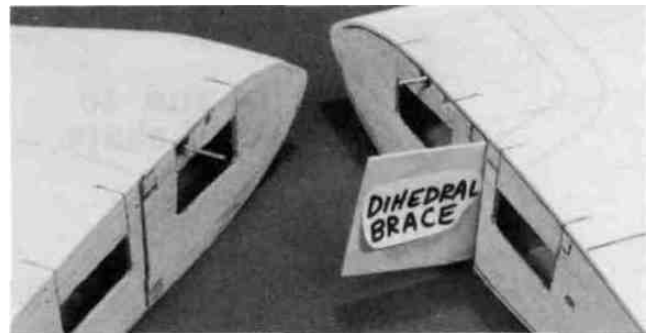

D 2. Trial fit the die-cut 1/16" ply dihedral brace to make sure it will readily slide into place.

NOTE: 30-minute epoxy is strongly recommended for the wing joining process.

D 3. Mix up a batch of 30-minute epoxy and push some into the dihedral brace slots. Smear epoxy on the spar ends, and on both sides of the 1/16" ply dihedral brace. Slide the dihedral brace in place, push the wing panels together and immediately proceed to the next step.

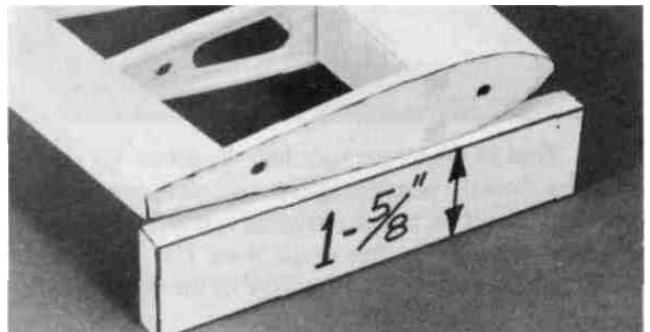

D 4. With the wing tips blocked up 1-5/8 inch, carefully align the LE and TE of both wing panels at the center and,

while holding them in correct alignment, apply thin CA glue to "lock" the panels together. Do not apply CA glue to any area that is already coated with epoxy. Allow the epoxy to fully harden before disturbing the wing.

D 5. Sand the wing joint smooth all around.

INSTALL AILERON TORQUE RODS

D 1. Roughen the short end of the aileron torque rods with 100-grit sandpaper, and file the same end to a wedge shape,

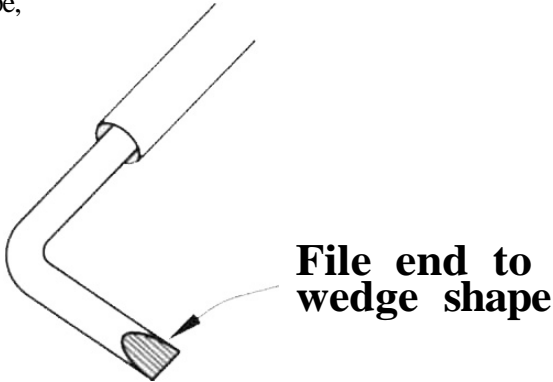

D 2. Roughen the surface of the plastic bearing tubes with 100-grit sandpaper.

D 3. Clean the torque rods and bearing tubes with alcohol.

D 4. Find the two grooved, tapered balsa center trailing edge pieces. Lay them on the plan, mark and cut them off to match the plan for length and angle at the centerline.

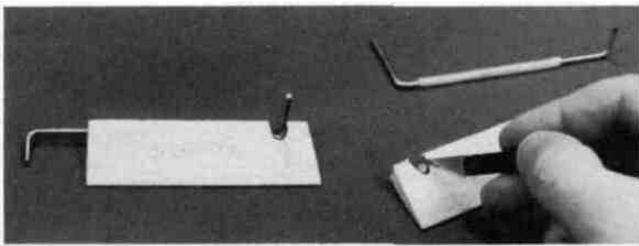

D 5. Trial fit the torque rods into the center TE pieces. Determine from the plan where to cut the clearance notches, which will permit the torque rod horns to travel freely. Also cut small clearance notches in the wing TE. Note: The torque rod horns must exit the TOP of the wing!

D 6. Slide the plastic bearings toward the threaded end of the torque rods, then use a toothpick to apply a small amount

of petroleum jelly to the ends of the plastic tubes (to help prevent glue from getting inside and locking up the torque rods).

D 7. Use 5-minute epoxy or thick CA to glue the plastic bearing tubes into the grooves in the center TE pieces. Wipe off any excess glue and allow it to harden.

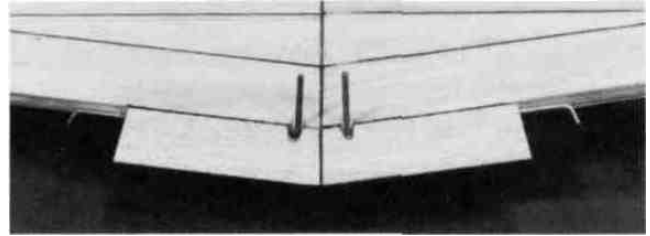

D 8. Trial fit the trailing edge / torque rod assemblies onto the wing trailing edge. Sand the center trailing edge pieces slightly where they join, for a good fit. Glue these pieces in place with epoxy. **HINT:** Use masking tape to hold these pieces to the wing TE, to aid in correct positioning.

SAND "FLAT" ON TE

D 1. Study the wing plan near the wing centerline. Note that the center portion of the TE must be sanded flat.

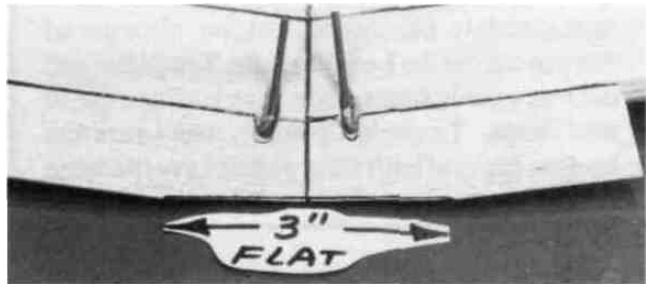

D 2. Sand approximately 1/4" into the TE at the centerline. (The flat will end up approximately 3-1/4" wide at the TE).

FIBERGLASS THE CENTER SECTION

NOTE: Because of the high stresses in the center of this wing, fiberglass reinforcement is REQUIRED. Please do not omit this important section!

NOTE: If you have previous experience with applying fiberglass, feel free to use your favorite method, providing that it results in a strong bond between the glass cloth and the wood. If this is your first time, we offer the following suggested method, which is the fastest and easiest we have seen.

D 1. Make location marks for the fiberglass reinforcement cloth, 2" each way from the wing centerline.

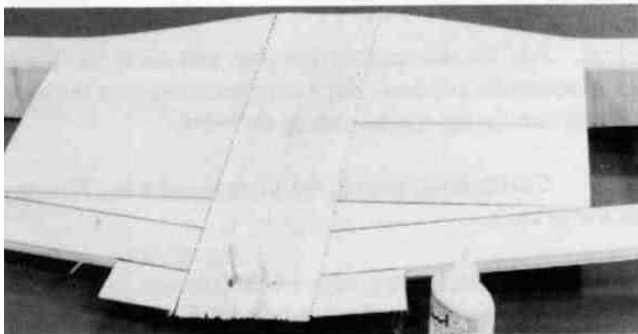

D 2. **Trial fit** the 4" wide fiberglass cloth in place. You can use a scissors or a paper punch to cut holes in the glass cloth for the aileron torque rod horns.

D 3. Wrap small pieces of masking tape around the threaded portion of the aileron torque rods to protect them from the spray adhesive in the next step.

D 4. Spray a very light mist of 3M "77" Spray Adhesive on the center section in the area to be glassed. Hold the spray can at least 12" away from the surface when doing this to avoid a heavy buildup. The purpose of this is only to give the wood a little "tackiness". If you apply too much spray it could result in a poor glue bond. Allow the spray to dry for 5 minutes before proceeding to Step 5.

D 5. Beginning at the trailing edge, lay the glass cloth in place on the wing. Gently press the cloth in place, working out all the wrinkles. The "77" spray adhesive should hold the cloth down to the surface, but will permit you to lift and reposition the cloth if you make a mistake. Keep working forward along the top of the wing, around the leading edge, and along the bottom of the wing, ending at the trailing edge. Do not attempt to wrap the glass cloth around the trailing edge.

D 6. Working outdoors or in a very well-ventilated area apply thin CA glue to the glass cloth. Begin by running a bead of glue down the center of the glass cloth strip, then continue applying the glue in lines until all the cloth has been secured. Run the thin CA out 1/4" beyond the edges of the

glass cloth to help protect the balsa sheeting when sanding later. **WARNING:** This operation produces a larger than normal quantity of CA fumes, so adequate ventilation is a must!

D 7. Inspect the surface of the glass cloth. If any areas are not glued down, apply a couple more drops of CA glue and press down with a piece of waxed paper until the glue sets.

D 8. To make sure the glass cloth is fully "wetted out" and bonded to the balsa, you may apply more thin or medium CA, a few drops at a time, and spread it out with a piece of waxed paper.

D 9. After the glue has set, trim the excess cloth at the trailing edge with a sharp Xacto knife followed by a sanding block.

D 10. Carefully sand the edges of the glass cloth with a T-bar sander with 80 or 100-grit sandpaper. Also, lightly sand the surface of the glass cloth with a piece of sandpaper held in your fingers to remove any rough spots. **WARNING:** When sanding fiberglass, wear safety goggles and a dust mask to avoid breathing airborne glass fibers.

INSTALL WING TIPS

NOTE: The wing tips will be carved from the 1-3/8" x 1-3/8" x 7-3/4" balsa blocks.

D 1. Draw a centerline on the ends of the wing and on the wing tip blocks.

D 2. Securely glue a wing lip block to the left end of the wing, and **tack glue** a wing tip block to the right end of the wing, lining up the centerlines you previously drew. You will later break only the right tip loose and hollow it out.



D 3. Cut, carve and sand the wing tips to the appropriate shape as shown on the plan. **HINT:** Use 50-grit sandpaper and a sharp wood chisel or razor plane to speed up this operation. **NOTE:** Leave the tips oversize in the area of the trailing edge, for now.

NOTE: Step 4 is for side mounted or upright mounted engines only.

D 4. Cut the right wing tip loose from the wing and use a Dremel Moto Tool to hollow out the wing tip. (This will help to compensate for the weight of the engine head and muffler).

D 5. Now securely glue the right wing tip in place.

D 6. Cut a 1-1/4" piece from each aileron for the fixed outboard TE, and cut one end of these pieces to an angle to match the plan. Glue these pieces to the wing, positioning them carefully so they line up with the top and bottom of the wing.

D 7. Sand the wing tip to blend with the TE piece you just installed.

INSTALL AILERONS

NOTE: Do not glue the aileron hinges until after your model has been covered.

U 1. Draw an accurate centerline along the LE of the tapered balsa ailerons and the wing TE.

D 2. Check the length of your ailerons against the actual aileron openings and trim the ailerons as necessary. You should provide approximately 1/16" gap at each end of the ailerons.

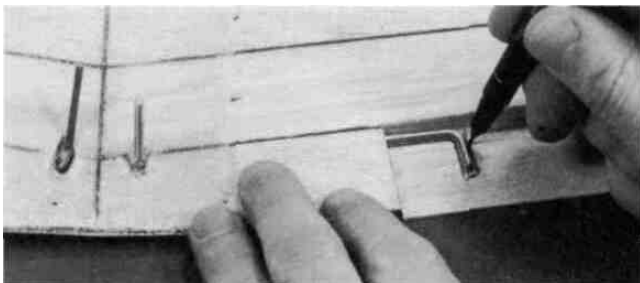

D 3. Lay the ailerons in place in the openings, with the torque rods resting on top of the ailerons. Mark the torque rod locations on the top of the ailerons.

D 4. Drill a 7/64" hole in the ailerons at the torque rod locations, starting at the leading edge centerline and drilling **straight** in to the proper depth. (The hole is drilled slightly oversize to allow for positioning, and to create a hard epoxy "sleeve" around the wire).

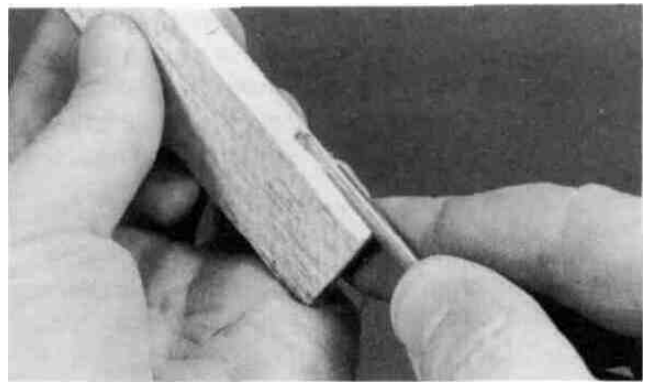

D 5. Use the sharpened 1/8" diameter brass tube to cut a groove in the leading edge of the ailerons to accept the torque rods. Trial fit the ailerons onto the torque rods and cut or file as necessary until they fit.

D 6. Lay the ailerons on the plan and mark the hinge locations on the ailerons. Place the ailerons against the wing TE and transfer the marks over to the wing.

D 7. Cut the hinge slots in the ailerons and wing TE using an Xacto knife.

D 8. Sand the leading edge of the ailerons to the same "V-shape" as shown on the wing rib detail drawing.

D 9. Insert the hinges into the slots and trial fit the ailerons in place on the wing. Do not glue the hinges until after you have covered the wing.

There should be no hinge gap!

TEMPORARILY INSTALL WING DOWELS



D 1. Mark a horizontal centerline on the wing LE. Also mark a vertical centerline on the die-cut 1/8" ply former F-2A.

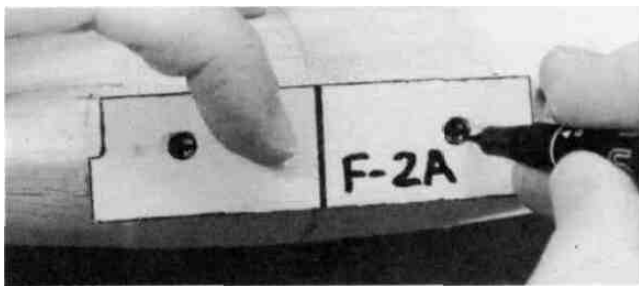

D 2. Holding the die-cut 1/8" ply **F-2A** on the leading edge, in the exact center of the wing, mark the dowel locations through the holes in F-2A.

D 3. Remove F-2A and double check to make sure the dowel locations are both the same distance from the wing center joint.

D 4. It is important that you now drill the dowel holes accurately! To insure accurately positioned holes, begin by drilling small (1/8") holes in the center of the marked locations. Then gradually increase drill bit sizes until you have finally drilled the holes to 1/4" diameter. The final holes you drill must extend at least 1-3/4" into the wing to penetrate the inner dowel plates.

D 5. Sand **one end** of each wing dowel to a rounded or pointed shape. This is the end that will be inserted. Do not sand the other end at this time.

D 6. Trial fit the dowels into the dowel holes, and trial fit F-2A over the dowels. If the dowels fit too tightly, you may enlarge the holes slightly using a round file, or you may sand the dowels down slightly. **Do not** glue the dowels in place at this time.

INSTALL WING BOLT PLATE

D 1. Mark a centerline on the die-cut 1/16" x 3" x 1-1/4" ply wing bolt plate.

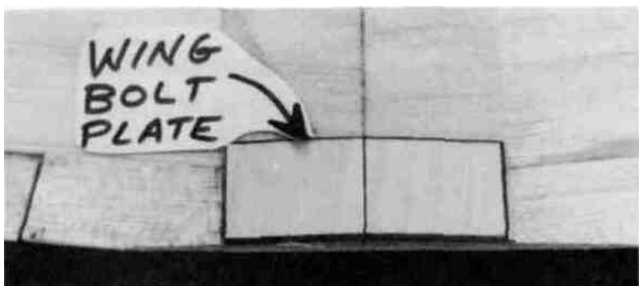

D 2. Position the wing bolt plate on the **bottom** of the wing, and line it up with the wing TE and centerline. Glue it in place.

D 3. Sand the wing bolt plate flush with the wing TE.

FILL LANDING GEAR SLOTS (Fixed gear only)

D 4. Temporarily install the main LG wires.

D 2. Check the plan for the location of the nylon landing gear straps and temporarily install them, using #2 x 3/8" sheet metal screws-



NYLON LANDING GEAR STRAP



#2 X 3/8" SHEET METAL SCREW

D 3. Using scraps of balsa, fill the ends of the slots in the notched LG blocks and sand flush with the surface of the wing. This will aid in covering later.

INSTALL LANDING GEAR COVERS

(Optional)

NOTE: If you are installing a retractable landing gear, please refer to the special instructions included in the next section (page 20).

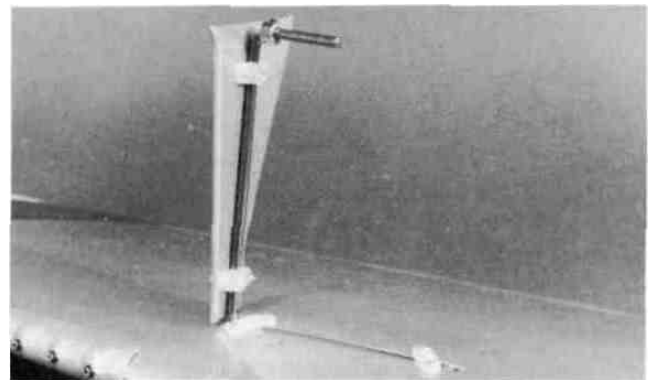

D 1. Find the two die-cut 1/8" ply landing gear covers, and sand the front and rear edges to a slightly rounded shape.

D 2. Mount the L.G. covers to the main landing gear, using the nylon "hump" straps and the #4 x 3/8" sheet metal screws. Drill 1/8" holes in the landing gear covers, and pass the screws through the holes, screwing them into the nylon straps, as shown in the sketch.

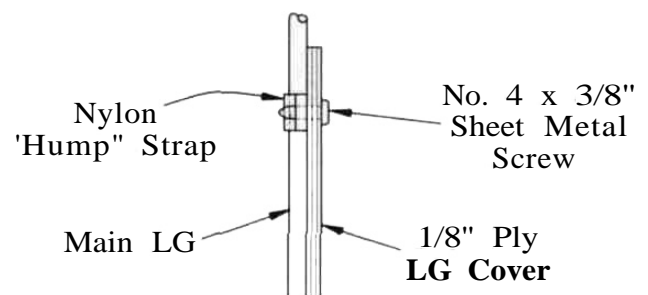

D 3. Adjust the position of the L.G. covers to match the plan. The top edge of the L.G. covers must be at least 1/4" away from the wing, to reduce the possibility of damaging the wing in a hard landing.

INSTALL RETRACTS (OPTIONAL)

NOTE: Hardware for retract installation is not included in the kit.

At this point most of your retract installation should already be completed, and all that remains is to install the retract servo and "fine tune" the installation.

D 1. If you have not already done so, cut the bottom sheeting away in the areas of the retract mechanism, LG wire and wheel well.

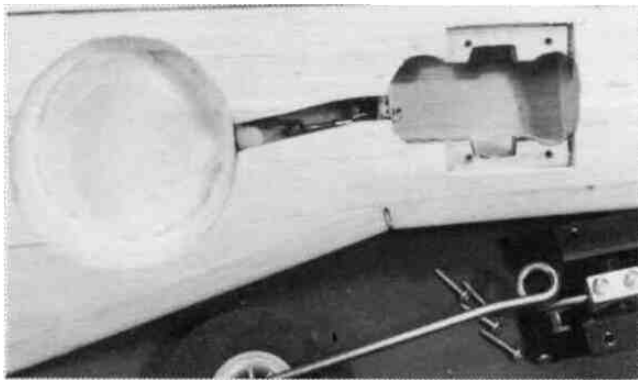

D 2. Using 1/16" or 3/32" balsa, construct a "floor" in the wheel well, to conceal the pushrod tube, and to help seal off the wheel well from the interior of the wing.

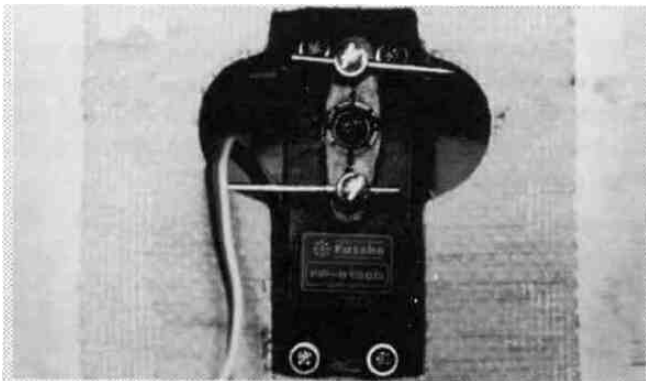

D 3. Cut out an opening in the top sheeting in the area of the retract servo. Cut out a portion of the W-1 ribs to fit your servo, and fabricate two 1/8" ply servo mounting rails in the general area shown on the fuse plan side view. Install the retract servo, and attach the pushrods to the servo by means of EZ Connectors as shown.

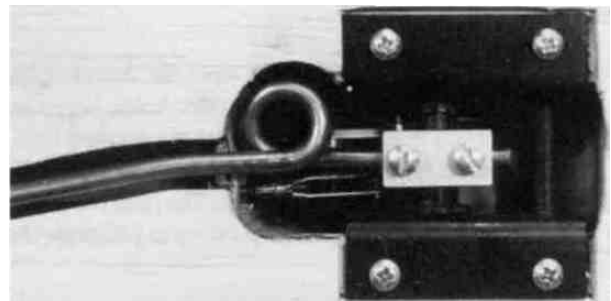
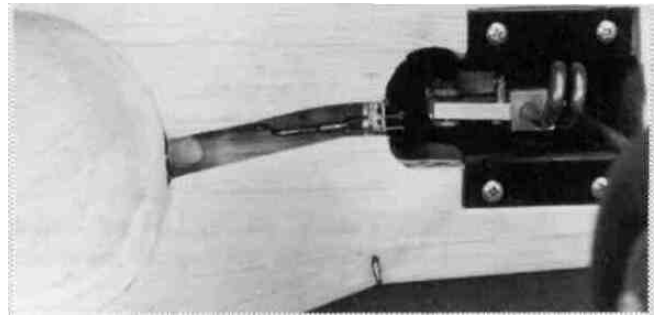

D 4. Temporarily install all retract components. Test the operation of your retracts making sure they operate freely and reliably. Also make sure they "lock" in both the up and down positions. In the retracted position, the LG wire should be just inside the LE sheeting.

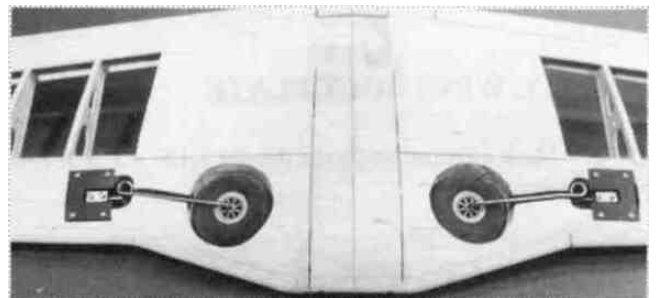

D 5. Blend the bottom sheeting as neatly as possible around the retracts.

D 6. Add lightweight balsa filler inside the wheel well to smooth any imperfections, and to fillet the joint between the floor and the sides.

D 7. Use polyester resin or 30-minute epoxy thinned with alcohol to fuelproof the entire retract area and wheel well area.

D 8. When installing the landing gear covers (optional), it may be necessary to add plywood shims between the L.G.

cover and the nylon straps, to raise the L.G. cover flush with the surface of the wing.

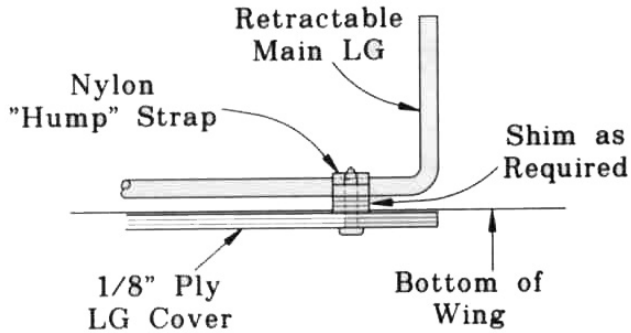

D 4. Trim and sand off the die-cut "bumps" from the front and rear portion of the lower rear fuse side, blending with the upper fuse side.

D 5. Inspect the glue joints for gaps, adding thick CA glue if necessary. Sand the glue joints smooth on both sides using a T-bar and 100-grit sandpaper, then repeat the above steps to make the other fuse side.

D 6. Place the two assembled fuse sides together. Sand the edges as necessary to make the two sides identical.

FUSELAGE ASSEMBLY

PREPARE FUSE SIDES

D 1. Lay one of the shaped 1/8" balsa fuselage sides in place on the fuselage plan side view. Carefully position the fuse side so the front edge lines up with the front of F-1 on the plan. Tape or pin the fuse side so it can't move. NOTE: The fuse side may be a little longer at the rear than indicated by the plan. This is as it should be.

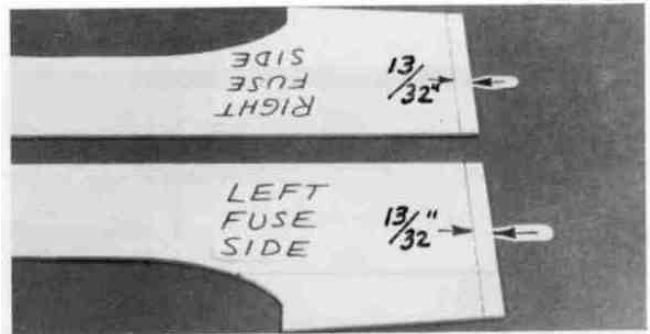

D 7. As shown in the above photo, designate the fuse sides "RIGHT" and "LEFT". From the front edge of both sides, accurately measure back 13-32" and draw a line parallel with the front edge.

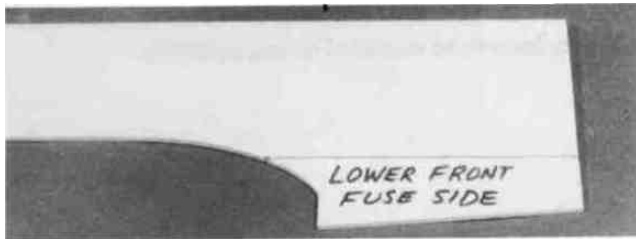

D 2. Carefully position the die-cut 1/8" balsa lower front fuse side so the rear edge lines up with the front of the wing saddle opening on the plan (the rear edge of F-2A). You may have to lightly sand the top edge of the die-cut 1/8" balsa for a good fit against the bottom edge of the fuse side. Edge glue the lower front fuse side to the fuse side. NOTE: Use waxed paper under the balsa to avoid gluing to the plan.

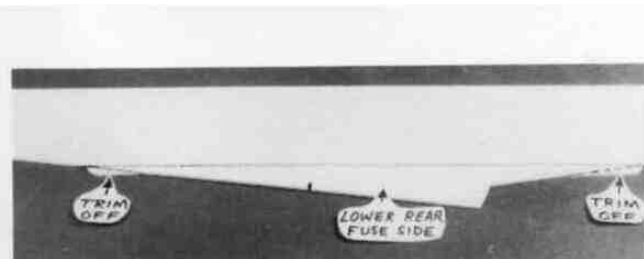
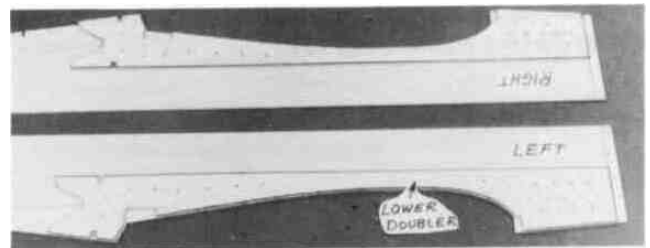

D 8. Find the die-cut 1/8" balsa lower fuse side doublers. Position them on the fuse sides, carefully lining up their front edges with the 13/32" lines you previously drew. Line up the aft portion of the lower doublers with the bottom edge of the fuse sides.

REMEMBER: You must make a LEFT and a RIGHT fuse side!

Glue the lower doublers to the fuse sides by applying thin CA all around the edges while holding the doubler firmly in place. The thin CA will not penetrate far enough from the edges, so you must also apply a few drops of thin CA in each of the pinholes in the doublers (see the dots in the photo).

D 3. Carefully position the die-cut 1/8" balsa lower rear fuse side so it lines up with the plan. Edge glue the lower rear fuse side to the fuse side.

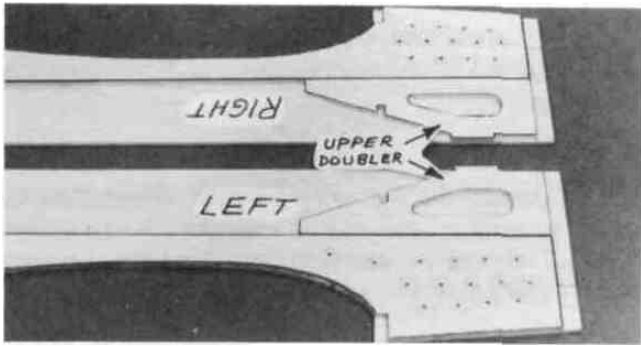

D 9. In the same manner, glue the die-cut 1/8" balsa upper fuse side doublers to the fuse sides, with the front edge also on the 13/32" line.

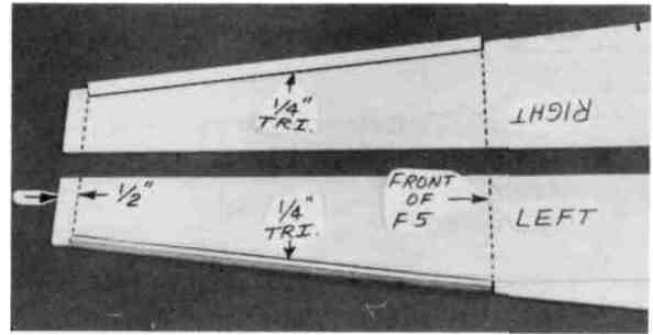

D 13. From the 1/4" x 24" balsa triangle stock, cut two pieces to run along the inside bottom edge of the fuse sides, starting at the front of the tail wedge, and running forward to the front edge of F5.

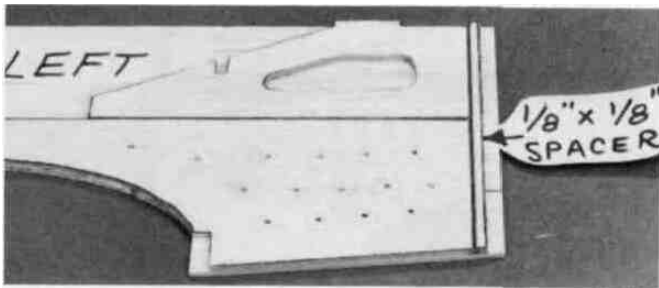

D 10. Find the 1/8" x 1/8" x 3-7/8" hardwood spacer and glue it to the front edge of the die-cut 1/8" balsa fuse doublers on the left fuse side. (This will automatically position the firewall for 2-degrees of right'thrust). The spacer must be lined up with the top edge of the upper doubler.

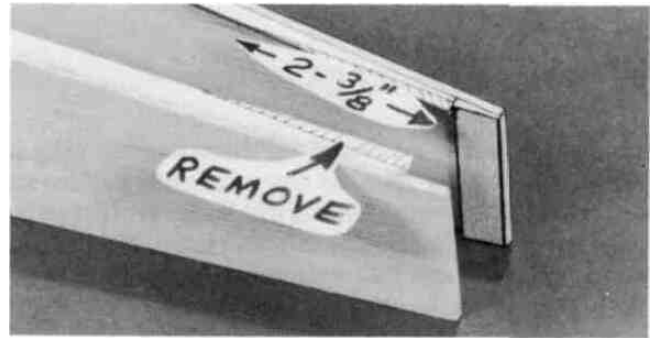

D 14. Sand the aft ends of the balsa triangles to a taper, which will permit the fuse sides to be pulled together at the aft end. **NOTE:** The taper shown in the photo is approximate and may have to be modified during assembly.

D 11. Align the left fuse side on the fuse plan side view, and mark on the fuse side the location of the front edge of former F5 (See photo at step 13).

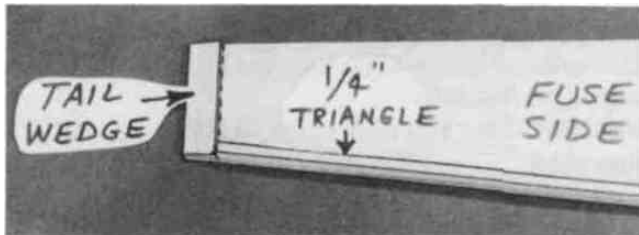

D 12. Glue the tapered balsa tail wedge to the aft end of one of the fuse sides and sand it even with the top and bottom edges.

PREPARE THE FIREWALL (F1)

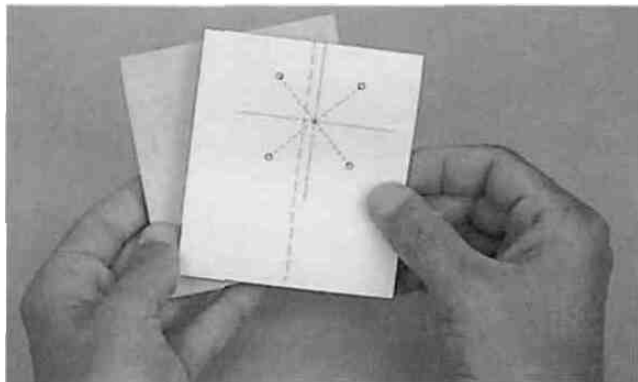

D 1. Cut out the F1 template from the fuselage plan sheet. Tape the template to F1 and use it as a guide to locate the four holes. Drill $3/16$ " holes at the bolt locations. Install the 6-32 blind nuts on the back of F1. Press the blind nuts in with a vise, or tap them in with a hammer.

Note: The engine mount centerline is offset by $5/32$ " to compensate for the right thrust.

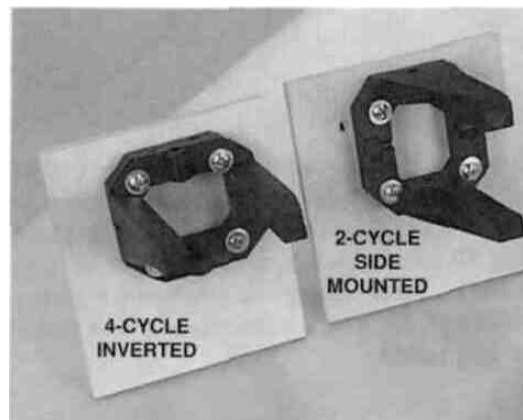

D 2. Temporarily attach the engine mount to the firewall with the 6-32 x 1" bolts and #6 flat washers.



6-32 X 1"
Machine Screw



#6 Flat Washer

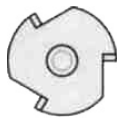

6-32
Blind Nut

ASSEMBLE THE LOWER FUSELAGE

D 1. Tape the fuselage plan to your workbench and cover the Fuse Bottom View with waxed paper.

Note: The fuselage is assembled upside down.

D 2. Pin or tack glue (using 3M "77" Spray Adhesive) the $1/8$ " die-cut balsa stab base accurately in position on the plan. Align the front edge of the stab base with the line on the plan.

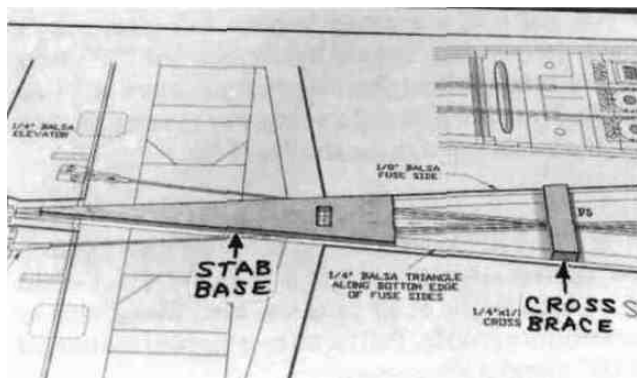

D 3. Accurately position the pre-cut $1/4$ " x $1/2$ " balsa cross-brace on the plan, and pin it in place behind F-5.

D 4. Trial fit former F-5 to the front of the cross-brace (the former is upside down) and sand the edges of F-5 slightly to match the angle of the fuse sides. Glue F-5 to the cross-brace, making sure it is installed perpendicular to the building surface.

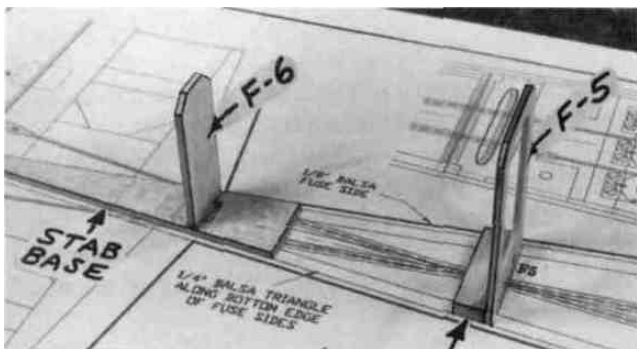

D 5. Insert F-6 upside down in the rear of the slot in the stab base. Sand the edges of F-6 slightly to match the angle of the fuse sides. Align F-6 perpendicular to the stab base and glue it in place.

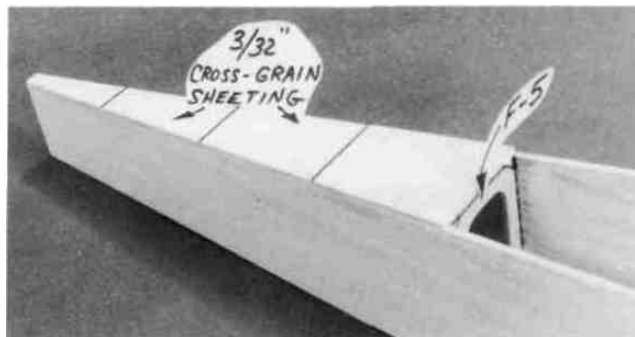
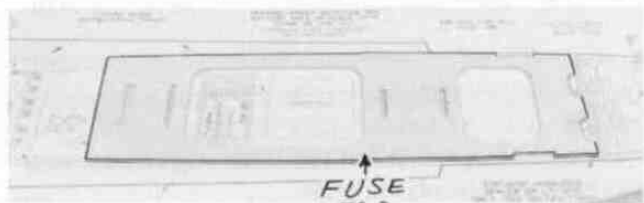

D 6. Accurately position the 1/8" die-cut ply fuse top on the plan and hold it securely in place with pins, tape or weights (or you may spray it lightly with 3M "77" spray adhesive, to hold it firmly but temporarily down on the plan). **NOTE:** There is a right and a wrong way to install the fuse top! It must line up with the aft edge of F-1.

D 7. Trial fit (do not glue) the following parts together: Fuse top, fuse sides, die-cut 1/8" ply F-2, F-3, F-4, F-5 and F-6. Check the fit of all parts and trim, file or sand as necessary for a good fit. Pull the aft ends together and re-sand the 1/4" triangles if necessary.

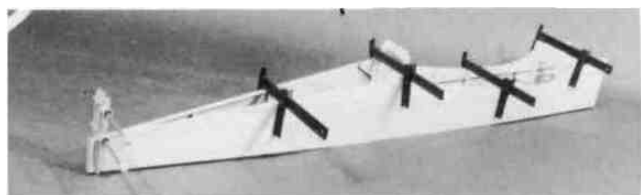

D 8. Once you have everything fitting properly, re-assemble the above parts, using clamps, pins, tape and weights to hold everything together and flat on the workbench. Make sure F-2 is pushed as far forward as possible. There should be waxed paper underneath to prevent gluing the fuse to the plan. Apply medium or thin CA glue to the joints, then follow with thick CA glue in all joints. **NOTE:** It is difficult to get sufficient glue down to the stab bed, so make a mental note to add glue in that area after removing the structure from the workbench.

D 9. Sand the bottom of the fuse to remove any excess glue, and to provide a flat surface for the sheeting.

D 10. From the 3/32" x 3" x 24" balsa sheet, cut and glue pieces of cross-grain sheeting to the bottom of the fuse, beginning at the middle of F-5 and running to the aft end of the fuse. The photo for this step is at the top of the next column.

D 11. Now you may remove the fuselage from the work surface and sand the edges of the bottom sheeting flush with the fuse sides.



D 12. Find the 1/4" ply wing hold-down block and trial fit it into the notches in the fuse side doublers, sanding as necessary for a good fit. Glue the hold-down block in place securely, using 30-minute epoxy, then cut pieces of 1/4" balsa triangle and glue them in place only between the wing hold-down block and the wing saddle. Sand the triangles flush with the wing saddle.

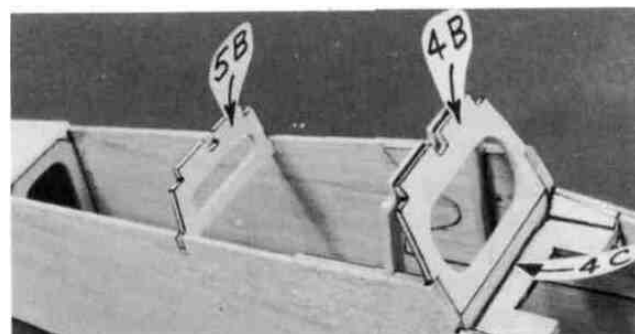

D 13. Glue the die-cut 1/8" ply formers **F-4B**, and **F-5B** in place. Now find the die-cut 1/8" balsa former **F-4C** and glue it in place behind the wing hold-down plate.

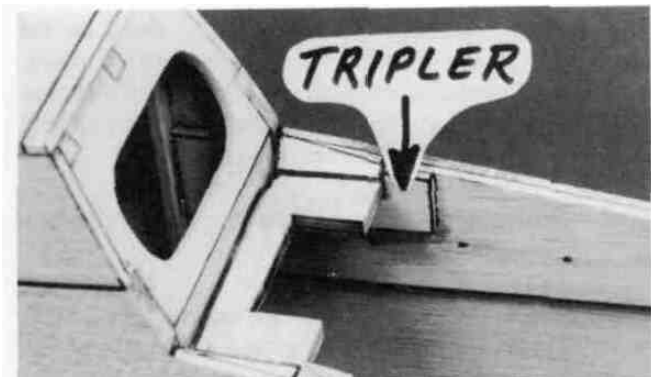

D 14. Find the die-cut 1/8" ply hold-down plate TRIPLERS, and epoxy them in place around the hold-down plate and F-4C. The aft edge of the triplers should be securely glued to F-4.

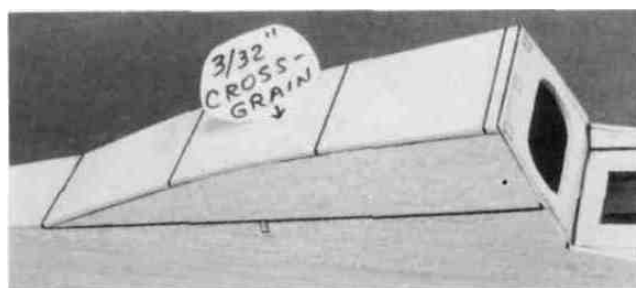

D 17. From the remaining 3/32" x 3" balsa sheet, cut pieces of cross-grain sheeting, and glue them to the bottom of the air scoop, from F-5 to F-4B. Sand the edges of the bottom sheeting to blend with the scoop sides.

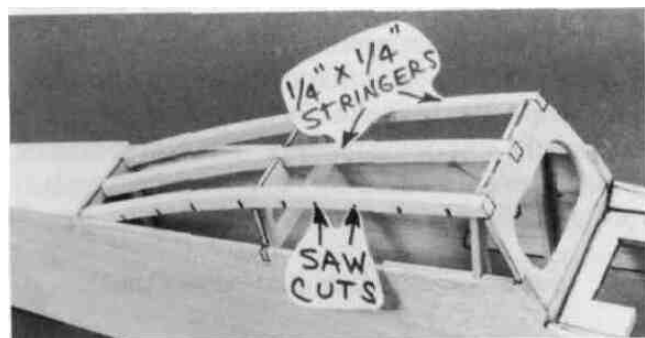

D 15. From the 1/4" x 1/4" x 30" balsa sticks, cut three air scoop stringers approximately 9-1/4" long. Glue these stringers in place from F-5 to F-4B. If the balsa is too hard to permit easy bending, make several saw cuts, as shown in the photo. Sand the ends flush with F-4B, and sand the edges of these stringers to blend with the edges of F-4B and F-5B.

D 16. Glue the die-cut 1/8" balsa rear scoop sides in place, then trim and sand the edges to blend with the stringers and F-4B. The photo for this step is at the top of the next column.

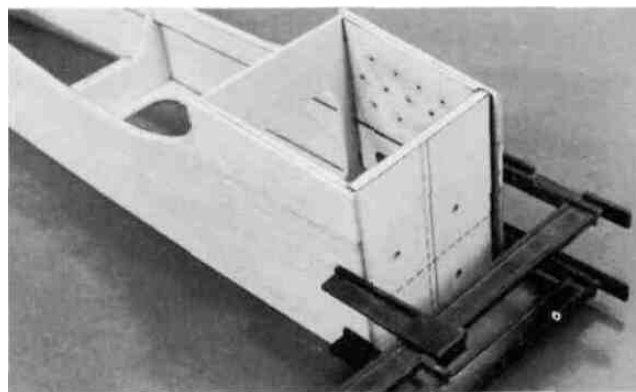

D 18. Use 30-minute or 5-minute epoxy to securely glue F-1 to the fuse sides, holding with clamps or tape until the glue has firmly set. **NOTE:** Before the glue sets, double check to make sure F-1 is properly aligned with the top and bottom edges of the fuselage, and fully back against the fuse doubler and spacer. After the glue has fully hardened, sand off the front of the fuse sides flush with the front of F-1.

Drill Engine Mount

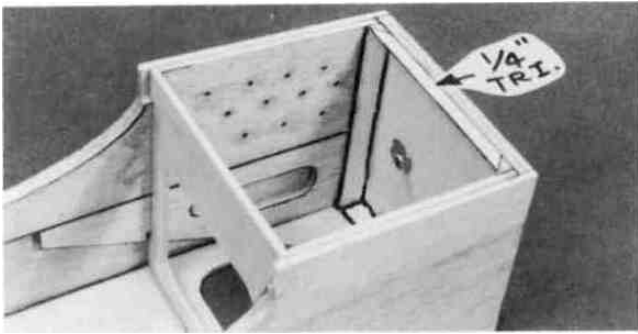

D 19. Cut pieces of 1/4" balsa triangle to fit around the aft edges of F-1, and glue them in place.

D 20. Find the two 9/16" x 2-1/16" x 4-1/4" balsa blocks and edge glue them together to make the chin block.

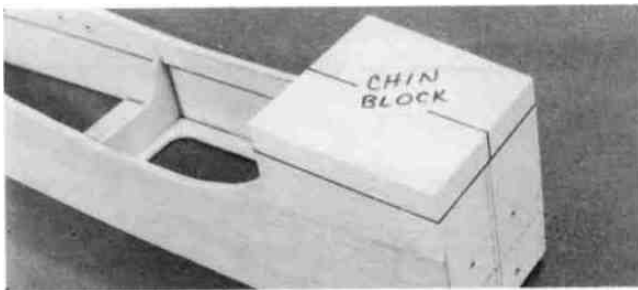

D 21. Sand the bottom edges of the fuse sides, F-1 and F-2 to make a flat, even surface for the chin block. Glue the chin block in place as shown on the plan. **NOTE:** The aft edge of the chin block must extend at least 1/8" behind the aft edge of F-2. Now sand the edges of the chin block even with the fuse sides and the front of F-1. Sand the aft edge of the chin block to a slight angle as shown on the plan. You may temporarily lay F-2A in position as a guide when sanding the aft edge of the chin block.

D 1. Place the engine pointing straight ahead on the mount and mark the mounting hole locations on the mount. At the marked locations, accurately drill 7/64" (or #36) holes. **NOTE:** If you have access to a drill press, use it for drilling these holes to insure that they are drilled vertically.

D 2. Now you may use one of the following methods to attach your engine to the mount:

Method 1: Screw the #6 x 3/4" sheet metal screws (provided in the kit) through the engine mounting flange and into the mount. When first installing these screws, put a drop of oil into each screw hole.

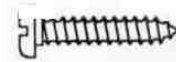

Method 2; Cut threads into the holes you just drilled using a 6-32 tap and tap wrench. If you use this method you'll have to supply your own bolts (6-32 x 1" socket head cap screws) for attaching the engine to the mount. **NOTE:** 8-32 hardware is recommended if you are installing a 4-cycle engine.

INSTALL PUSHROD GUIDE TUBES

NOTE: Although you may choose to wait until later, this is the best time to install the pushrod guides, because the fuselage is wide open and it is very easy to work inside.

IMPORTANT: Before proceeding, plan your servo and pushrod installation. Especially note on which side of the fuselage the throttle pushrod will be located. Remember that the throttle arms of 2-cycle and some 4-cycle engines arc on opposite sides. It will be helpful to actually sketch your pushrod locations on the plans with a pencil. It is desirable for the throttle pushrod to run along the side of the fuselage. It is also desirable (but not essential) for the rudder and elevator pushrods to cross inside the fuselage, to avoid any sharp bends.

D 1. Set the fuselage upside down on your workbench.

D 2. Trim the 3/16" x 1/2" x 3-5/8" ply servo rails to fit between the fuse sides in the locations shown on the plan. You may use the die-cut 1/8" balsa servo lockplates (doublers) to temporarily hold the servos in place while fitting the pushrod guide tubes by taping them to the fuse sides, but do not glue the servo rails in place yet. You'll want the flexibility of moving the servos forward or aft to aid in balancing later.

D 3. Sand the outer surface of the pushrod guide tubes with 100-grit sandpaper to provide a surface to which the glue will adhere.

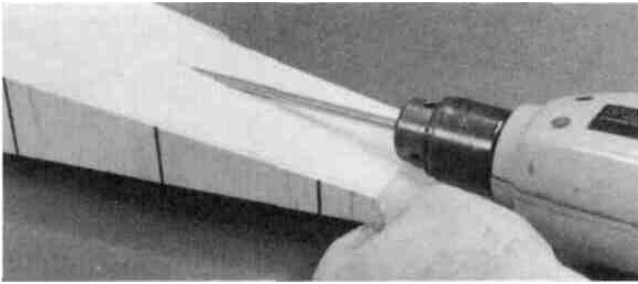

D 4. Use an Xacto knife to sharpen one end of a piece of 3/16" (outside diameter) brass tubing, then use this tubing to cut the pushrod exit holes (you may use a 3/16" drill bit, but the brass tube method gives a much neater cut). Determine the location of these holes from the plans. You may chuck this brass tube in an electric drill to aid in getting through F-6.

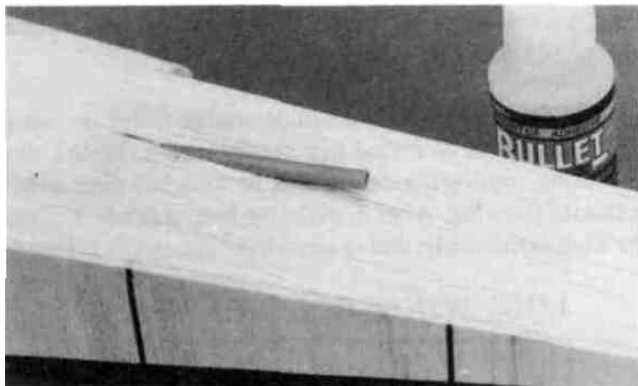

D 5. Cut one of the plastic outer pushrod tubes in half and insert the tubes through the holes you just cut and through formers F-6, F-5 and F-4.

D 6. Route the pushrod tubes according to your radio installation plan. Temporarily insert the 34" pushrod wires into the tubes and hold them in the correct position (with tape) at the servo end. **Keep the tubes as straight as possible.** Glue the tubes to the fuse sides at the rear exit points using thin CA glue. Use scraps of 1/8" balsa to anchor the tubes to F-5. **Do not anchor the tubes to F-4 at this time,** to allow for slight adjustment of their positions later.



D 7. Cut off the tubes at the exit points and sand them flush with the fuse sides using a sanding block.

D 8. Temporarily install the engine mount.

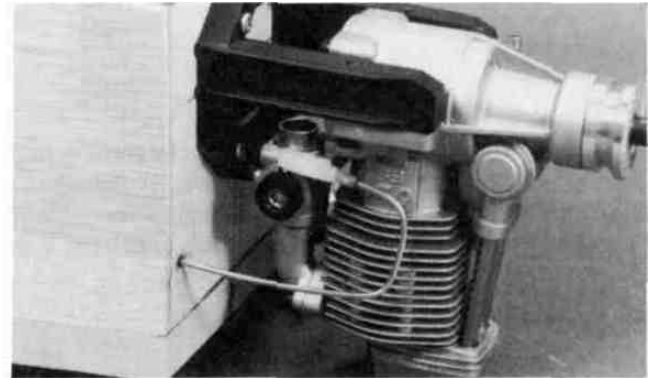

D 9. With the engine resting on the mount, plan the **throttle pushrod routing**. The pushrod should be located as close as possible to the fuse sides (to allow room for the fuel tank), and the guide tube should not have any tight bends. Drill a 3/16" hole in F-1 for the throttle pushrod guide tube, but stay at least 1/4" in from the outside edge of the fuse sides.

D 10. Drill or carve holes in F-2 and F-3 for the guide tube. Use the remaining 36" plastic pushrod guide tube and trial fit the tube in the fuselage.

D 11. Sand the plastic pushrod guide tube with 100-grit sandpaper, then glue it in place. Trim and sand the tube flush with the front of F-1.

D 12. Cut the **pushrod wire** (supplied) to the required length, add a nylon clevis, and trial fit the throttle pushrod.

D 13. Now remove the pushrod wire, servos and engine.

MOUNT THE WING TO THE FUSE

D 1. Sand the top surface of the fuse to remove any excess glue so the fuse will lie flat on the workbench.

D 2. Sand the entire wing saddle area lightly until the fuse side doublers and fuse sides are flush.

D 3. Insert the die-cut 1/8" ply F-2A in place against the back of F-2 (do not glue).

D 4. Insert the 1/4" wing dowels into the wing so they stick out only 1/8".

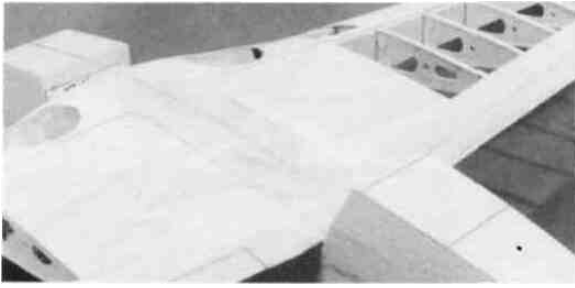

D 5. With the fuselage upside down on a flat surface, trial fit the wing into the wing saddle. If the wing is slightly too large (front to rear) to fit into the saddle, sand the rear edge of the saddle and the wing trailing edge slightly until it fits with approximately 1/32" to spare.

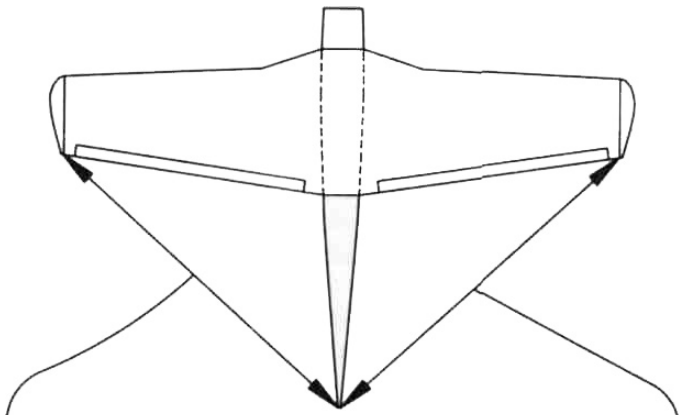

Measurements must be equal

D 6. Carefully **align** the wing in the saddle as follows:

If you have drilled the dowel holes accurately, the wing should now be **centered**, side to side. Measure down from the bottom of both tip ribs to the flat surface. If the measurements are not equal (within 1/16"), sand the saddle slightly until the wing sits level in the saddle. Also measure from the rear corner of each wing tip to the tail end of the fuselage. These measurements must also agree within 1/16". If not, shift the wing slightly until they do. With the wing in this position you may now check the wing **incidence** using an "incidence meter" or by measuring down to the flat surface from the center of the leading and trailing edges. The measurements should be the same (zero degrees incidence). **CAUTION: If your flat surface is not level**, you will get erroneous incidence readings! If you are working on a flat surface that is not level, you must set the wing incidence the same as your flat surface.

D 7. After making the necessary corrections to align the wing, **tack glue** F-2A to F-2 with a couple drops of medium or thick CA. Also make **alignment marks** on the wing TE and the front of F-4B so you may easily re-align the wing later.

D 8. Remove the wing and securely glue F-2A in place by flowing thin CA into the wing dowel holes and around the edges. Follow up with thick CA around the edges.

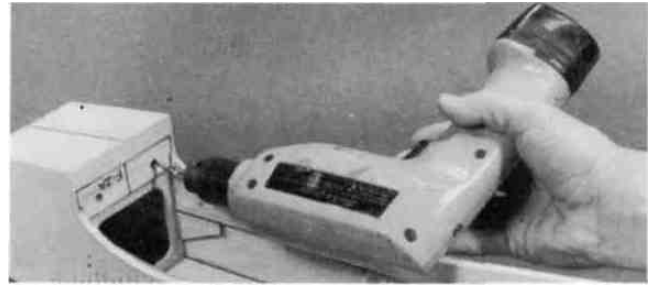

D 9. Drill 1/4" holes through F-2 using the holes in F-2A as a guide.

D 10. Use a pliers to grasp the ends of the wing dowels and pull them out. Now you may slightly round (or chamfer) the ends of the dowels for easier insertion into F-2A. Mix up a batch of 30-minute epoxy (for maximum strength), use a small stick to work plenty of epoxy into the dowel holes, smear epoxy on the dowels, then re-insert the dowels into the wing, leaving them protrude 3/8". Wipe away all excess epoxy, then allow the epoxy to fully harden.

D 11. Study the wing plan to determine where the wing bolt holes are to be drilled (see the following sketch). By measuring, transfer the locations to the wing bolt plate on the bottom of the wing. After marking the bolt locations, replace the wing in the saddle and re-align it accurately, as in step 6.

1/16" WING BOLT PLATE

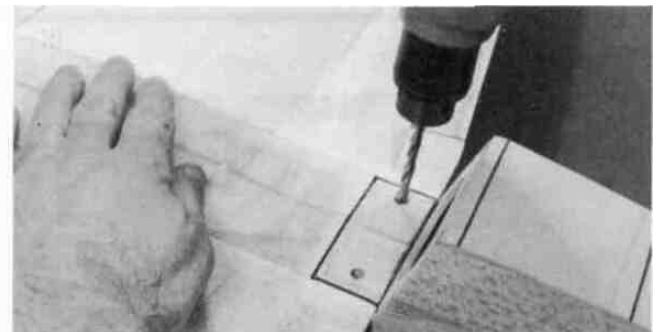
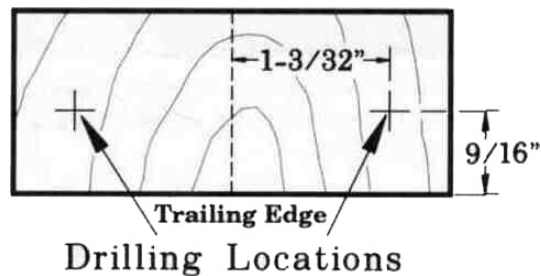

D 12. Holding the wing **firmly** in place, drill 13/64" holes at the locations you marked in step 11, drilling down through the 1/16" ply wing bolt plate and through the 1/4" ply hold-

down plate in the fuselage. Try to drill straight in, perpendicular to the 1/16" ply bolt plate. **IMPORTANT!: Do not allow the wing to move while drilling!**

D 13. Remove the wing and re-drill the holes **in the wing only** to 1/4".

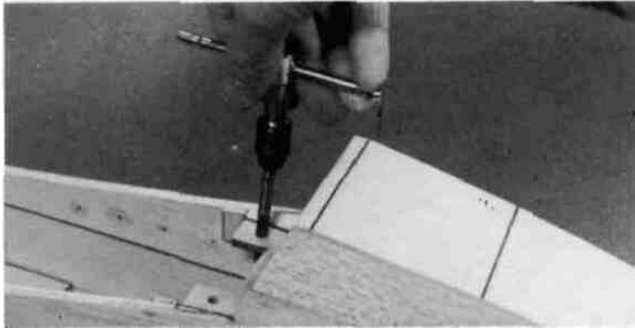

D 14. Use a 1/4-20 tap and a tap wrench to cut threads in the ply hold-down plate in the fuselage.

D 15. **Harden** the threads in the hold-down block with thin CA glue, then re-tap the threads after the glue is **completely** dry.

D 16. **Trial Fit** the wing to the fuse using the two 1/4-20 nylon bolts provided. You may cut the bolts off to their proper length, so they protrude about 1/4" below the hold-down plate **in** the fuselage,

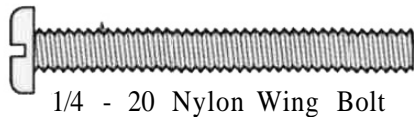

D 17. Later you will apply foam **wing seating tape** or **silicone sealer** to the wing saddle. To allow space for this wing cushion material, you may sand the saddle **slightly** in the areas where the wing touches the saddle, to provide a small gap.

FIT FUEL TANK and FUELPROOF TANK COMPARTMENT

D 1. Assemble your **10 oz. fuel tank**. We recommend bending the brass tubes as shown in the photo to prevent them from cutting through the silicone fuel lines if pressed against the firewall. (Try not to "kink" the tubes when bending, however).

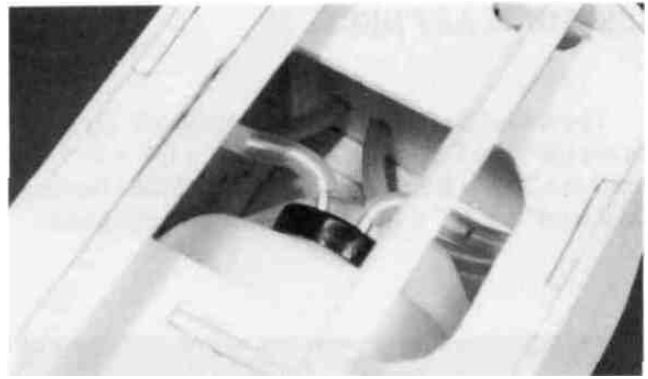

D 2. Try sliding the tank in through F-2. If the opening is not large enough, sand or file the opening until the tank slides **in** easily.

D 3. Temporarily install the engine mount and note how far the mounting screws protrude into the fuel tank compartment. Remove the screws and cut them off so they do not protrude more than 1/8" (to prevent puncturing the fuel tank).

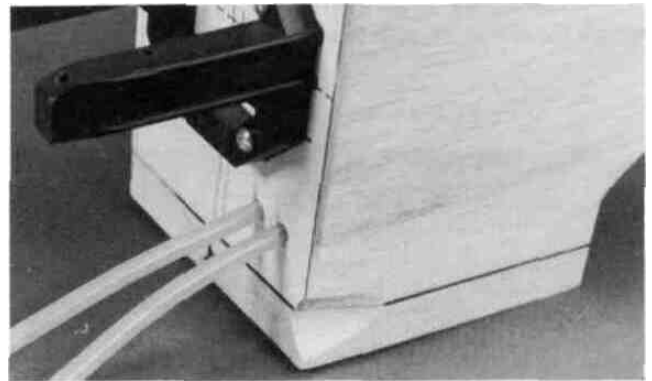

D 4. Drill two holes (7/32" or size to fit your fuel tubing) for your **fuel tubing** vent and fill lines. The location of these holes will depend somewhat upon the type of engine you are using, and whether or not you will be using an external fueling valve, such as the "Dubro #334 Kwik-Fill Fueling Valve."

D 5. Now remove the engine mount and **fuelproof** the inside of the fuel tank compartment and the front of F-1 by brushing on a coat of polyester resin or 30-minute epoxy thinned with alcohol.

D 6. You may permanently install the **fuel tank** at this time, or you may wait until the plane is nearly completed. If you do it now it will be easier to feed the fuel lines through F-1, and to make sure there are no kinks in the lines; however, you'll have to work around them while completing the nose. When you install the tank, be sure to **cushion** it from vibration and prevent it from moving by surrounding the tank on all sides (and front) with **latex foam rubber**. Leave several inches of extra fuel tubing in front of F-1 (you can cut off the excess later). The photo at step 2 shows how to route the fuel tubing to prevent kinking.

ASSEMBLE AFT DECK

You'll need the following parts: Die-cut 1/8" ply F-4T, die-cut 1/8" balsa F-5T and F-6T; two 1/4" x 1/4" x 30" balsa sticks; two 3/32" x 2-5/8" x 14" balsa aft deck side sheeting; and the 1/4" x 1-3/8" x 13-3/4" balsa aft deck top block.

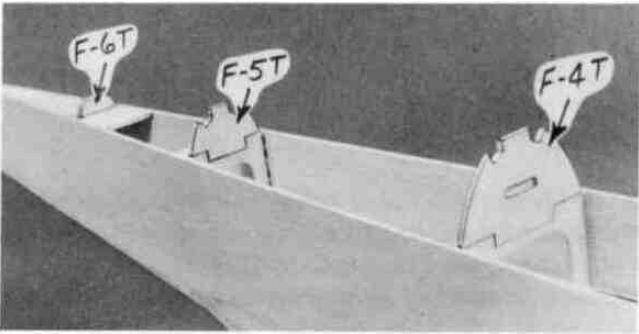

- D 1. Glue F-4T to the top of F-4.
 Glue F-5T to the top of F-5.
 Glue F-6T to the front of F-6 (insert the F-6T tab through the slot in the stab base).



- D 2. Glue the 1/4" x 1/4" balsa stringers into the notches in the formers. **NOTE:** The ends of the stringers butt against the front of F-6T. Trim and sand the ends of the stringers flush with the front of F-4T.

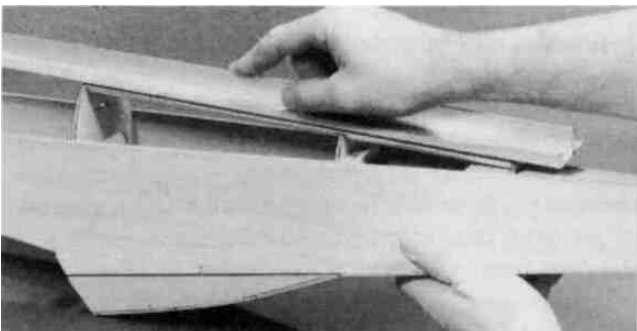

- U 3. Use a sanding block to sand the sides of the stringers to blend with the formers (see the cross-section drawings on

the plan). Also use a long sanding block to sand the stringers and the tops of the formers in a straight line from F-4T to F-6T.

- D 4. Prepare the aft deck sides by cutting the 3/32" x 2-5/8" x 13-3/4" balsa sheet to the angle shown in the following sketch.

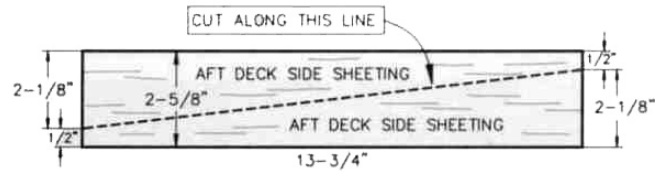

- D 5. Trial fit one edge of the sheeting down onto the top of the fuse side. Sand the edge of the sheeting if necessary, for a good fit.

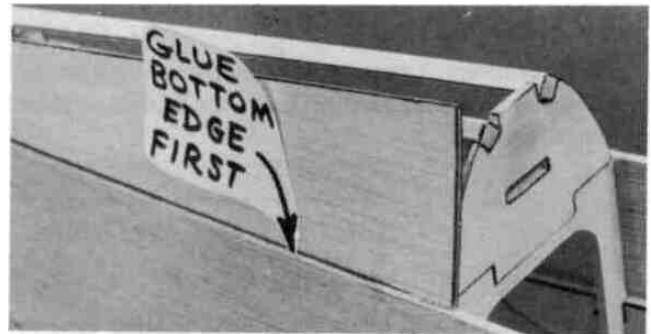

- D 6. Glue the bottom edge of both side sheets to the top of the fuse sides. **NOTE:** The outside edge of the sheeting is inset approximately 1/16" from the outside edge of the fuse side.

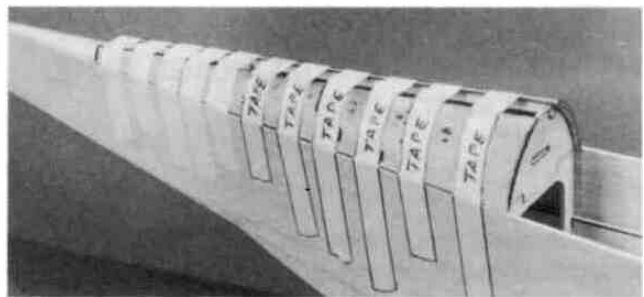

- D 7. Wet the outside surface of the sheeting with a damp rag to permit easier bending. Apply thick CA glue to the edges of the formers and the stringers, then immediately bend

the sheeting around the formers and onto the stringers. **HINT:** This requires about 5 sets of "hands," so use several long pieces of masking tape to pull the sheeting together; then, working a small section at a time, add CA and press the sheeting to the stringers.

D 8. Trim and sand the sheeting flush with the front of F-4T and the rear of F-6T.

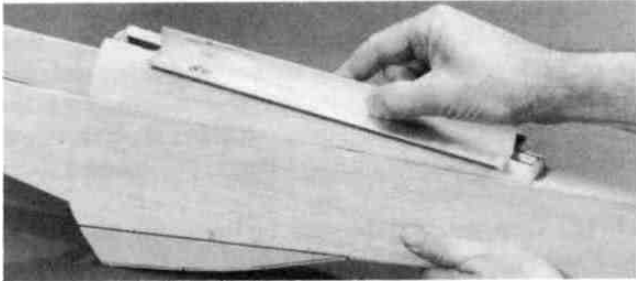

D 9. Using a long T-bar or sanding block with 80-grit sandpaper, sand the sheeting and stringers flush with the top edges of the formers.



D 10. Glue the 1/4" x 1-3/8" x 13-3/4" balsa aft deck top block to the tops of the formers, stringers and sheeting, then trim the ends of the top block flush with F-4T and F-6T.

HINT: In the next step it will be helpful in keeping the top block symmetrical if you first mark a fuselage centerline on the top of the top block from front to back (this is a line from the centerline of F-4T to the centerline of F-6T).



D 11. Carve and sand the top block to blend smoothly with the sheeting (see the cross-sections on the plan). **HINT:** Use

a razor plane (or a sharp wood chisel) and a sanding block with 50-grit sandpaper for rough shaping the top block. **Do not** yet blend the fuse sides into the aft deck sheeting.

ASSEMBLE FRONT DECK

You'll need the following parts: Die-cut 1/8" balsa F-1T, F-2T, and the DASH; also the 1/4" x 1/4" x 30" balsa sticks, the 3/32" x 2-5/8" x 20" balsa front deck side sheeting, and the 1/4" x 2-1/4" x 11-1/2" balsa front deck top.

D 1. Glue the die-cut 1/8" balsa F-1T former to the top of F-1. The front of F-1T must line up with the front of F-1. **NOTE:** Center F-1T between the left and right fuse sides.

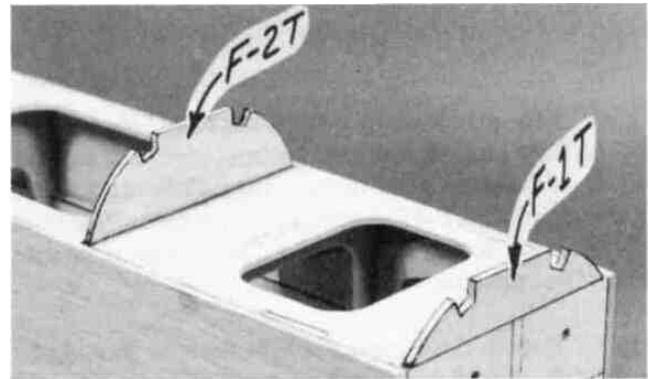

D 2. Glue the die-cut 1/8" balsa F-2T to the fuse top, using the notch provided for positioning.

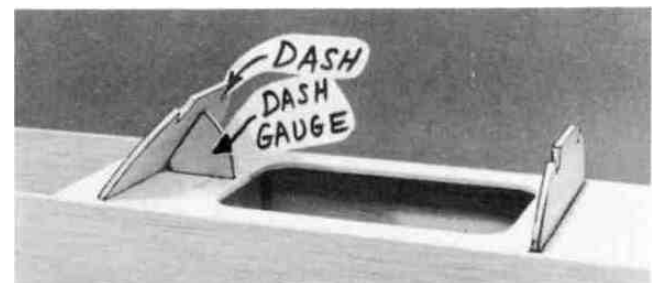

D 3. Glue the die-cut 1/8" balsa DASH in place in the wide notch in the fuse top. Use the small die-cut 1/8" ply dash gauge only for setting the dash at the correct angle.



D 4. From the 1/4" x 1/4" x 30" balsa sticks, cut two stringers to run from the dash to F-1T, and glue these stringers in place.

D 5. Sand the front and rear ends of the stringers flush with the formers. Lightly sand the stringers flush with the top and sides of the formers.



D 6. Edge glue the two 1/8" die-cut balsa halves of the cockpit floor together, and sand the front edge to an angle as shown on the plan. Trial fit the cockpit floor between the Dash and the slot in F-4T, sanding a little at a time off the front edge until the floor is parallel with the top edge of the fuse sides. Glue the cockpit floor in place.

D 7. Prepare the cockpit floor for the side sheeting by sanding the sides of the cockpit floor to the same angle as the Dash and F-4T.

D 8. Prepare the front deck sides by cutting the 3/32" x 2-5/8" x 20" balsa sheets to the shape as shown in the diagram on the plan.

D 9. Trial fit the bottom edge of the sheeting down onto the top of the fuse side. Sand the edge of the sheeting for a good fit.

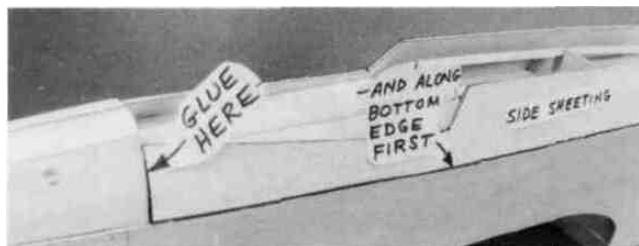

D 10. Glue the bottom edge of both side sheets to the top of the fuse sides, and glue the aft edge of the sheeting to match the aft deck sheeting.

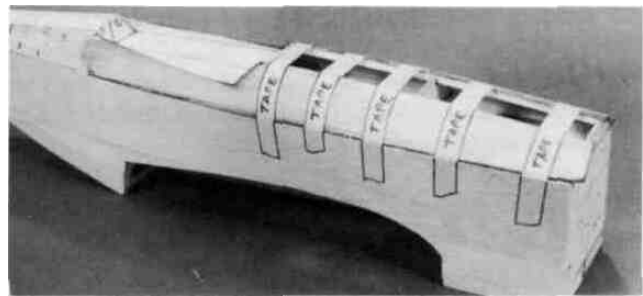

D 11. Wet the outside surface of the sheeting with a damp rag to permit easier bending. Apply thick CA glue to the edges of the formers, stringers and cockpit floor, then immediately bend the sheeting around the formers and onto the stringers. **HINT:** Use several long pieces of masking tape to pull the sheeting together; then, working a small section at a time, add CA and press the sheeting to the stringers.

D 12. Trim and sand the sheeting flush with the front of F-1T and the rear of the Dash.

D 13. Using a sanding block with 80-grit sandpaper, sand the sheeting flush with the top edges of the formers and stringers.

D 14. Glue the 1/4" x 2-1/4" x 11-1/2" balsa front deck top block to the tops of the formers, stringers and sheeting, then trim the ends of the top block flush with F-1T and the Dash. **NOTE:** In the event that the top block is too stiff to permit easy bending over the formers, you may have to make several equally spaced saw cuts halfway through the block (from the bottom).



HINT: In the next step it will be helpful in keeping the top block symmetrical if you first mark a fuselage centerline on the top of the top block from front to back (this is a line from the centerline of F-1T to the centerline of the Dash).

D 15. Carve and sand the top block to blend smoothly with the sheeting (see the cross-sections on the plan). **HINT:** Use a razor plane (or a sharp wood chisel) and a sanding block with 50-grit sandpaper for rough shaping the top block.

D 16. Now sand the fuse sides to blend with the aft deck and front deck side sheeting.

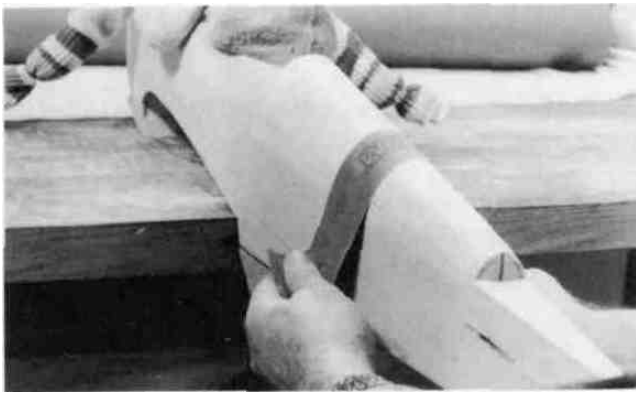

HINT: For a super-smooth and uniform finish on your deck, cut a 2-1/4" x 11" strip of 320 or 400-grit wet-or-dry sandpaper, and work it like a "shoe-shine cloth" across the top of the deck.

ASSEMBLE UPPER COWL

NOTE: The upper half of the cowl is constructed from wood, and is permanently attached and smoothly blended with the fuselage. This method was chosen to avoid that unsightly and unrealistic cowl line across the top of the fuselage that is so apparent with the P-51 models that employ a 1-piece cowl.

To build the upper cowl you'll need the following:

- 1/4" shaped balsa cowl sides (2)
- 1/4" shaped balsa cowl top
- 1/4" x 1-3/4" x 4-7/8" balsa sheets (2)
- (The above parts are packaged separately in a bag)
- Die-cut 1/16" ply spinner backplate

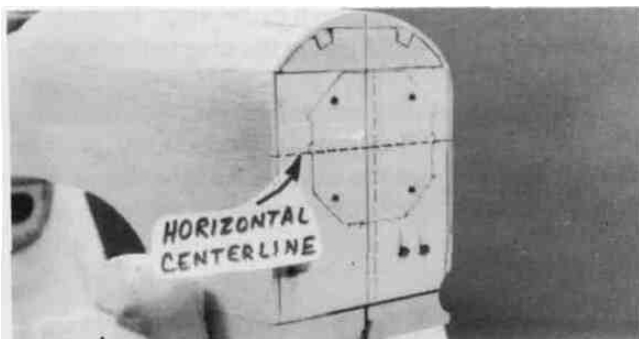

D 1. Accurately mark a horizontal centerline on F-1 to represent the center of the engine.

D 2. Attach the engine mount to F-1, and attach the engine to the mount. **NOTE: Mount the engine INVERTED for this process, even if you will later be side mounting it.**

D 3. From a scrap of 1/8" ply, cut four small pieces and tack glue them to the 1/16" ply spinner ring as shown, using a very small amount of thick CA (these will be removed later).

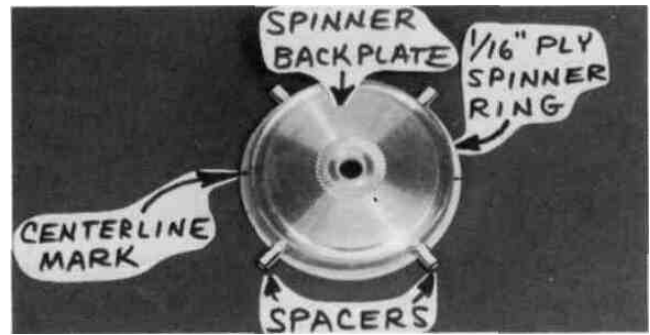

D 4. Now center your 2-3/4" diameter spinner backplate over the spinner ring, and tack glue it to the 1/8" ply spacers.

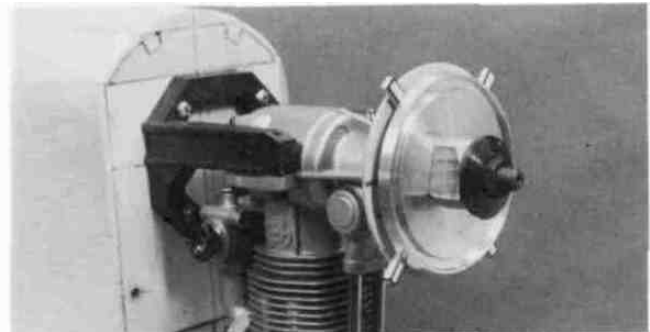

D 5. Slide the spinner ring / spinner backplate assembly onto the driveshaft and temporarily hold in place with the prop and prop nut. Notice the two embossed centerline marks in the spinner ring... the spinner ring should be positioned so these marks are exactly horizontal.



D 6. Sand the ends of the 1/4" balsa upper cowl sides to fit between F-1 and the spinner backplate. If you examine the fuse top view plan, you'll see that the outside edge of the cowl sides should be approximately 1/16" outside of the fuse sides and spinner ring. **IMPORTANT: The bottom edge of the cowl sides must be on the horizontal centerline that you previously drew on F-1, and on the horizontal centerline marks on the spinner backplate.**

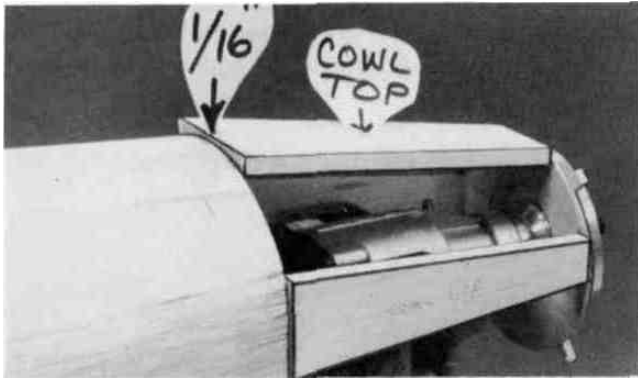

D 7. In the same manner, fit and glue the 1/4" balsa upper cowl top between F-1 and the spinner ring. Again, the cowl top should be approximately 1/16" above the front deck top block and the spinner ring.

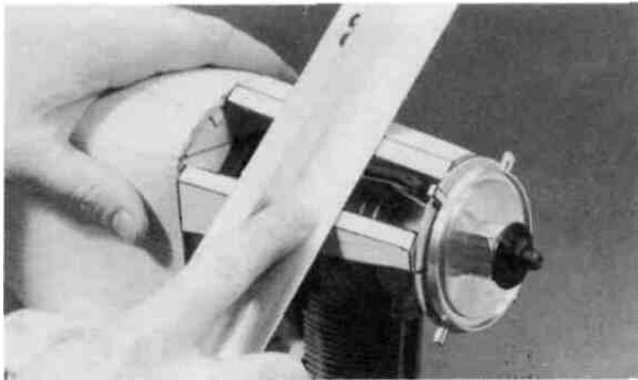

D 8. Use a sanding block to bevel the edges of the cowl sides and cowl top to a 45-degree angle. Sand deep enough so the corner blocks will be approximately 1/16" above the deck at F-1, and 1/16" above the spinner ring.



D 9. Sand the ends of the 1/4" x 1-3/4" x 4-7/8" balsa sheets to fit between F-1 and the spinner ring, then glue them in place as shown.

D 10. Sand the upper cowl to blend with the fuselage and your spinner backplate. Add scrap pieces of balsa and

lightweight balsa filler as needed to reinforce any thin spots or holes you may have exposed when sanding.

D 11. Remove the engine, and cut off the lower half of the spinner ring.

D 12. If your engine will be "side mounted," trim a semi-circle in the upper cowl to clear the engine head. Also provide clearance for the carburetor and needle valve as needed.

FINAL ASSEMBLY

INSTALL FRONT WING FAIRING

D 1. Carve and sand the 1" x 2-3/4" x 4-1/16" tapered balsa front fairing wedge to fit the front of the wing. **NOTE:** It is difficult (and not necessary) to carve this block to mate exactly with the wing; therefore, you should just "rough it out", then later you can fill any gaps with balsa filler.



D 2. With the wing in place on the fuse, hold the front fairing in place (allow 1/32" gap between the fairing front and the rear of F-2A) and tack glue it to the wing. **CAUTION: Use extreme care to avoid gluing the wing to the fuselage!**

D 3. Remove the wing and securely glue the front fairing block to the wing. Fill all gaps with balsa filler. After the filler has dried, replace the wing on the fuselage and sand the fairing block to smoothly blend the wing to the fuselage and chin block.

ASSEMBLE AIR SCOOP FRONT (On Wing)

You'll need the following parts:

Die-cut 1/8" ply F-4A

Die-cut 1/8" balsa F-3B, F-3C. Scoop Sides (2)*

1/4" x 1/4" balsa stick

3/32" balsa sheet

*NOTE: Because these parts are used to construct a section that is cosmetic only, they are made as lightweight as possible; therefore, they will be fragile until they are all glued together as an assembly. Handle with care! If you are planning to fiberglass and paint the fuselage and air scoop (not recommended, due to the potential for excess weight buildup), do not punch out the lightening holes in the scoop sides. Instead, glue them in permanently.

D 1. Mount the wing onto the fuselage and secure with the nylon bolts.

D 2. Take measurements from the fuselage plan side view and mark the locations of **F-3B** and **F-3C** on the bottom of the wing.

D 3. Trial fit **F-4A** onto the wing, sanding as necessary for a good fit. Glue **F-4A** to the wing, spacing it approximately 1/32" from **F-4B** (use a 1/32" plywood scrap as a spacer).

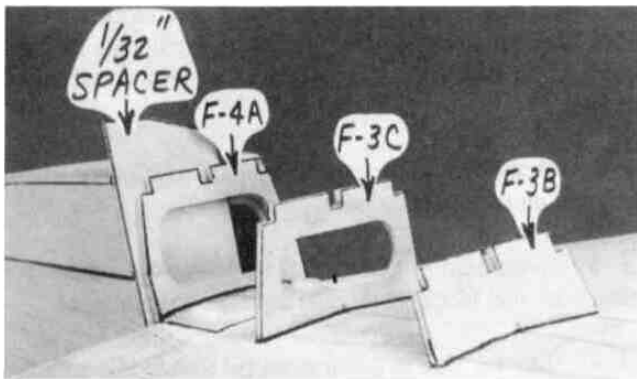

D 4. Trial fit and glue **F-3C** to the wing, roughly perpendicular to the wing surface.

D 5. Trial fit and glue **F-3B** to the wing, using the front edge of the Scoop Side as a guide for setting the angle of **F-3B**.

NOTE: It is recommended that you leave the wing attached to the fuselage during the next step to avoid changing the angle of **F-4A** when gluing the stringers to the formers.

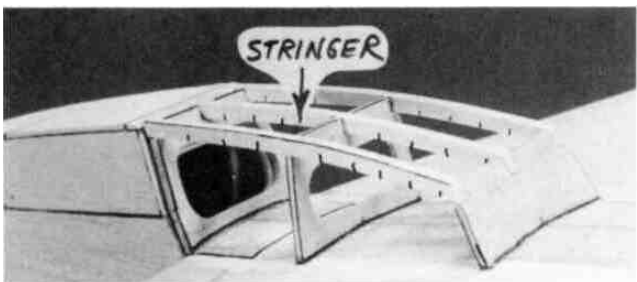

U 6. From the remaining 1/4" x 1/4" balsa stick, cut three stringers to run from the front of **F-3B** to the aft edge of **F-4A**.

Make saw cuts in the stringers as required for ease of bending. Glue these stringers in place, and sand off the ends flush with the formers. Also sand the edges of the stringers to blend with the formers.

NOW you may remove the wing from the fuse.

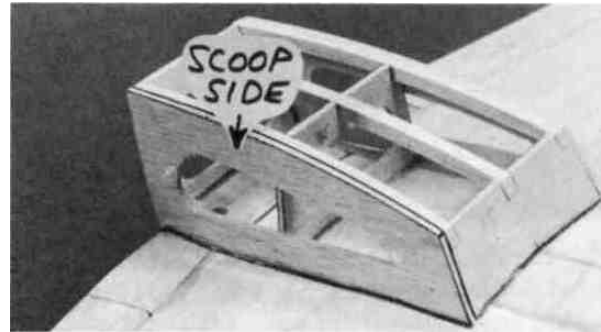

D 7. Sand the scoop sides for a good fit onto the wing, and glue them to the wing and to formers **F-3B**, **F-3C** and **F-4A**. Sand the edges of the scoop sides even with the edges of the formers.

D 8. If you had to make saw cuts in the stringers (step 6), you should now place a drop of thin CA on each saw cut.

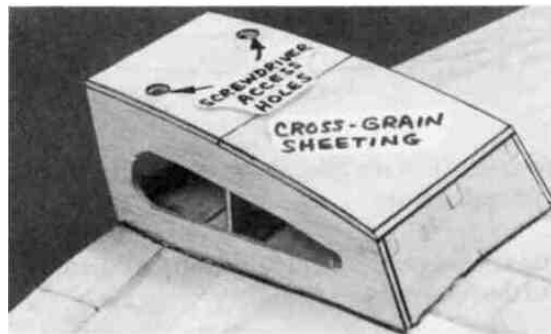

D 9. From the remaining 3/32" x 3" sheeting, cut pieces of cross-grain sheeting and glue to the bottom of the scoop. Provide holes in the bottom scoop sheeting for screwdriver access to the wing bolts.

D 10. Sand this scoop to blend with that portion aft of the wing.

INSTALL WING FILLETS (OPTIONAL)

NOTE: The wing fillets are a nice addition to the P-51 D. They make it more realistic and they do help to reduce drag. The P-51 D flies just fine without them, however, so the choice is yours whether or not to install them.

D 1. Tape an 8" x 16" piece of waxed paper onto the **top** surface of the wing at the center, then attach the wing to the fuse with the wing bolts.



D 2. Lay the die-cut 1/32" ply wing fillet bases on the wing and glue them to the fuselage sides. **NOTE:** For this procedure, we recommend that you use **thick** CA glue sparingly, and "kick" the glue with accelerator spray immediately after applying, to avoid accidentally gluing the wing to the fuse with "stray" glue. **NOTE:** Bend the aft 1-1/2" of the fillet base to horizontal (see sketch).

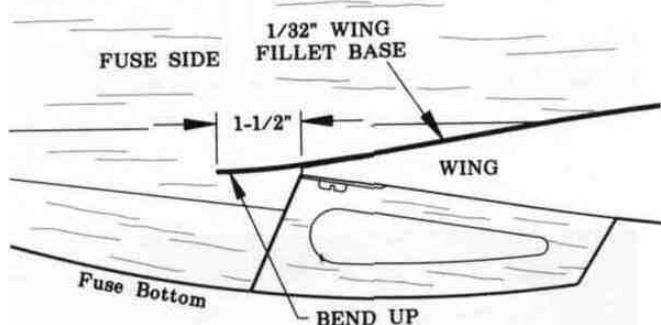

D 3. You may build the fillet on top of the fillet base in one of the following ways:

Method 1: Glue pieces of soft balsa onto the fillet bases, then sand to the fillet shape.

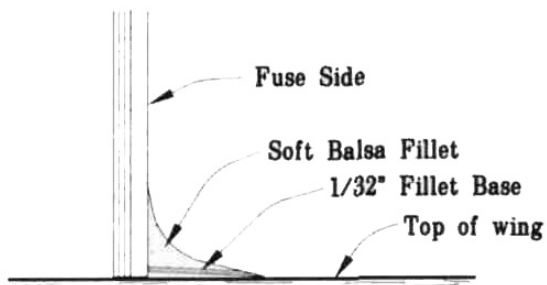

Method 2: Apply a good quality, lightweight model filler, shape it with a wet teaspoon, and allow it to dry **thoroughly** before sanding.

Method 3: A combination of the above, where you first glue pieces of balsa to partially fill the fillet area, then add filler to form the fillet shape.

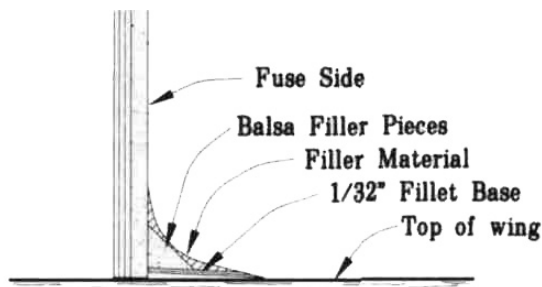

MOUNT STABILIZER AND FIN

D 1. Make sure the stab base is securely glued to the fuse sides, then lightly sand the **stab saddle area** smooth with a T-bar or sanding block. Draw a fuse centerline on the stab saddle, from the center of F-6T to the center of the aft end of **the fuse**.

D 2. Accurately measure the trailing edge of the stabilizer and mark the center point.

D 3. Temporarily mount the wing in the saddle (for reference), and block up the tips until the wing is level.

D 4. Lay the **stab** in position on the stab saddle with the stab centerline lined up with the fuse centerline. The front edge of the stab should be against the aft edge of F-6T. Carefully check the stab alignment by measuring down from the tips to a flat surface, and from the stab tips to the wing tips (or to a point on the center of the fuse near the nose). Sand the stab saddle (a **little at a time!**) until the stab rests in proper alignment. With the stab in alignment, make a mark on the front of the stab and a corresponding mark on the back of F-6T, which will be used for rapid alignment when gluing.

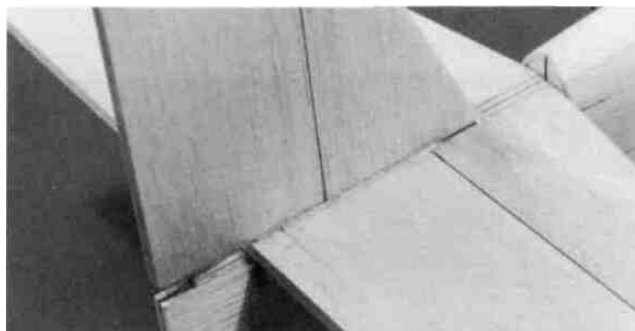

D 5. Mix up a batch of 5-minute or 30-minute epoxy and apply it to the stab saddle. Press the stab into position and

hold or pin in proper alignment until the glue has firmly set. Wipe off any excess epoxy before it sets up.

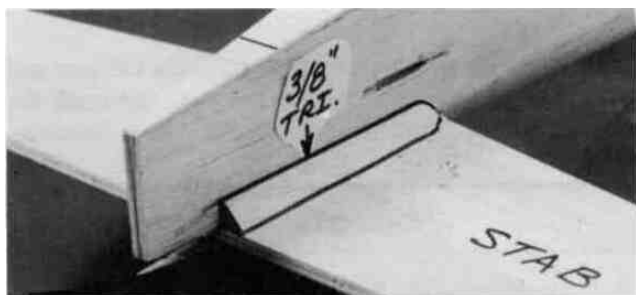

D 6. From the 3/8" balsa triangle supplied, cut and securely glue fillets **under the stab**, at the stab/fuse joint.

D 7. Trial fit the **fin** on the stab. **The fin trailing edge must line up with the aft end of the fuselage.**

D 8. Carefully align the fin on the stab. The fin must be **positioned perpendicular to the stab and must line up with the fuselage centerline EXACTLY!** Securely glue the fin in place with epoxy.

D 9. From 1/4" balsa scrap, cut a **filler** to fit between the fin leading edge and the aft edge of F-6. The top edge of this filler should be on the same line as the top of the aft deck.

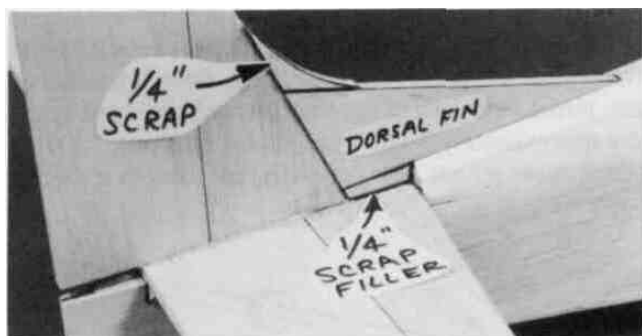

D 10. Glue the 1/4" balsa **dorsal fin** in place on the aft deck. The dorsal fin, like the fin, must also line up with the fuselage centerline. Sand the dorsal fin to a rounded shape, and blend it to the fin with balsa filler.

D 11. Shape another small 1/4" balsa scrap to blend the dorsal fin into the fin leading edge as shown on the plan.

D 12. Find the two 3/8" x 1/2" x 4-1/8" balsa blocks, and sand them as shown on the plan and in the photo to make the **fin fillets**. The fillets should blend smoothly with the aft deck. Securely glue the fillets in place on both sides of the fin. The photo for this step is at the top of the next column.



SHAPING AND SANDING

D 1. Using a sanding block and 80-grit sandpaper, **sand** the fuselage comers to a rounded shape. Refer to the cross-sections on the fuse plan, and try to sand the corners to the same shape as shown on the plan. Pay special attention to the fuse shape at F-1, as you will be fitting the cowl to this area later.

D 2. With the wing installed, sand the air scoop comers to a rounded shape, and blend the front portion of the scoop with the aft portion. Also, sand the comers of the wing fairing wedge to blend smoothly with the bottom front comers of the fuselage.

D 3. Vacuum the entire structure thoroughly, then inspect for any poorly glued joints and gaps. Apply additional glue and/or balsa filler as necessary, then sand the entire fuselage and wing smooth.

INSTALL PUSHRODS AND RADIO COMPONENTS

D 1. Study the plans to determine the location of the **aileron servo cutout**. Mark the location on the top of the wing and cut an opening in the fiberglass and sheeting slightly larger than your servo. **CAUTION: Do not cut into the wing spars or shear webs!**

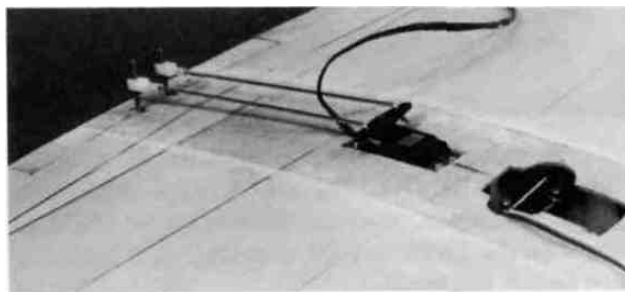

D 2. Remove a sufficient portion of the W-1 ribs to fit your servo, leaving "shelves" on which to glue the 1/8" ply rails. (See the plan to determine the depth). **NOTE:** A Dremel Moto Tool with a 1/8" router bit is excellent for this, but it may also be done with an Xacto knife and a long-nose pliers.

D 3. Make two aileron servo rails from the 1/8" ply die-cutting scrap, and glue them in place. (See the side view of the aileron servo installation on the plan).

D 4. Mount the aileron servo using the screws provided with your radio.

D 5. Screw the nylon aileron clevises approximately 2/3 of the way onto the threaded end of the two 12" steel wire pushrods.



NYLON AILERON CLEVIS AND CONNECTOR

D 6. Screw the nylon aileron clevis connectors onto the aileron torque rods.

D 7. Attach the clevises to the clevis connectors, then, with the ailerons in the neutral position, mark the pushrod wires where they cross the holes in the servo arm. Remove the pushrods and make a "Z-bend" in the rods at that point, using a "Z-bend pliers" or a standard pliers.

D 8. Remove the servo wheel from the servo and work the Z-bends into the wheel (**NOTE:** You may have to enlarge the servo wheel holes with a 5/64" diameter drill bit). Replace the servo wheel and check the operation of the ailerons. (See page 39 for the recommended amount of aileron movement).

REMEMBER: Plan your servo installation carefully, as your setup may differ from the plans and photos, depending on which engine you use.

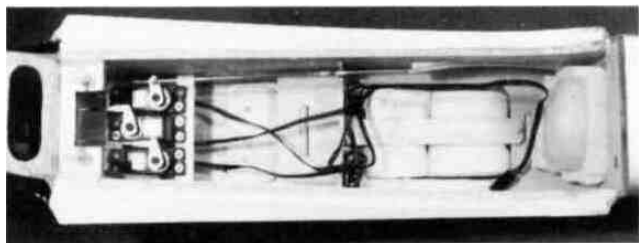

D 9. Re-mount the elevator, rudder and throttle servos in the fuselage. **BUT DO NOT GLUE THE RAILS IN PLACE!** Remember, you want to maintain the ability to move the servos if necessary for balancing. (See balancing section later in this book).

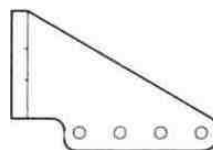

Nylon Control Horn

D 10. Hold the nylon control horns on the elevator and rudder in the positions shown on the plan and mark the mounting hole locations. Drill 3/32" holes at these locations.

IMPORTANT!

D 11. Harden the balsa in the area of the control horns (on both sides of the control surfaces) by poking several holes with a pin, then applying thin CA glue. Sand smooth.

D 12. Mount the horns with 2-56 screws and the nylon nutplates which were attached to the horns.



2-56 x 5/8 Machine Screw



Nutplate

D 13. Screw a nylon clevis onto the threaded end of each long steel wire pushrod. **NOTE; Screw them on all the way until the threads are protruding inside the clevis.**

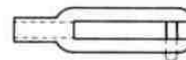

Nylon Clevis

D 14. Cut the short length of 1/8" diameter plastic tube into several pieces, approximately 1/4" long. Slide at least six of these pieces onto each of the long pushrod wires and space them approximately 2-1/2" apart (do not glue yet). **NOTE:** If these tubes do not slide on easily, cut them to a shorter length.

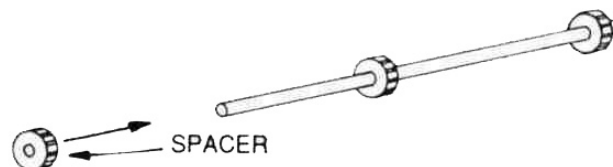

NOTE: While installing the pushrods, position the above plastic tube spacers so they always stay inside the pushrod guide tubes. If the tubes are not a tight friction fit on the pushrod wires, apply a drop of thin CA to secure them.

D 15. Insert the **pushrod wires** into the pushrod guide tubes (previously installed) and attach the clevises to the elevator and rudder horns.

The following steps (16 - 20) should be delayed and coordinated with the "balancing" section, later in this book.

D 16. While holding the rudder and elevators in the neutral position, mark where the pushrod wires cross the holes in the servo wheels where each pushrod will be attached.

D 17. Remove the elevator and rudder pushrods and make "Z-bends" at the marks you just made. Cut off the excess pushrod wire.

D 18. Unscrew the nylon clevises, re-insert the pushrods, and replace the clevises. Remove the servo wheels and work the Z-bends into the holes (drill out the holes in the servo wheels to 5/64" if necessary). Finally, place the servo wheels back onto the servos and check the operation of the elevator and rudder.

**We recommend the following
CONTROL SURFACE THROWS:**

NOTE: Throws are measured at the **widest part** of the elevator and rudder.

ELEVATOR: (High Rate)... 5/8" up
1/2" down
(Low Rate) .. 3/8" up
5/16" down

RUDDER: (High Rate).. 1-3/8" right
1-3/8" left
(Low Rate) .. 7/8" right
7/8" left

AILERONS: (High Rate)... 9/32" up
9/32" down
(Low Rate) .. 3/16" up
3/16" down

NOTE: If your radio does not have "dual rates", then set up the control surfaces to move at the **high rate** throws. These control surface "throws" are approximate and provide a good starting point for the first flights with your P-51D Mustang. You may wish to change the throws slightly to provide the smoothness or quickness that you prefer.

D 19. Securely anchor the pushrod guide tubes to F-4 using cross-braces cut from scrap 1/8" balsa.

D 20. Attach the throttle pushrod to the throttle servo. **NOTE:** We recommend using a DuBro "E-Z connector" (or similar) for this hookup, for ease of installation and adjustment.

D 21. If you are using retracts, install your retract servo at this time. Refer to the plans and photos.

D 21. Hook up your radio system and test the operation of all controls.

INSTALL RECEIVER, SWITCH AND BATTERY

D 1. Wrap your receiver and battery in plastic bags, then wrap with foam rubber.

D 2. Secure the battery to the fuselage just aft of F-2. The battery must be secure, but must be surrounded by foam rubber to protect it from hard vibrations. Therefore, after wrapping with foam rubber, we recommend securing it to the fuselage with a plywood restraint similar to that shown on the plan, or using hooks and rubber bands. **NOTE:** If you later find the airplane to be tail-heavy, it may be necessary to move the battery to a location under the fuel tank (in front of F-2).

D 3. Secure the receiver to the fuselage, just aft of the battery, in the same manner.

D 4. Route the receiver antenna in one of the following ways:

a. Route the antenna along the inside of the fuse side and out of the fuse top, just behind the canopy. Anchor the antenna to the top of the fin with a rubber band.

b. From the receiver, run the antenna directly through the left fuse side, then back to the stab.

c. Install another "pushrod guide tube" along the inside of the fuse, along the bottom, exiting just forward of the tailgear. Insert the antenna through the tube, and leave the excess length trail behind.

D 5. Mount the on-off switch to the front of F-3, using double-sided "servo tape," and run a 1/16" pushrod wire out the left side of the fuse, so you can operate the switch without removing the wing.

FIT COWL

NOTE: Photos show 2-cycle engine, side mounted with Tatone "Pitts-style" muffler.

D 1. If you examine the cowl carefully, you will see some faint guidelines for trimming. These lines are more visible on the inside of the cowl. Following these guidelines will result in a cowl that is just slightly oversized, which allows you to "fine tune" the fit of the cowl.

D 2. Trim the excess material from the cowl, along the guidelines.

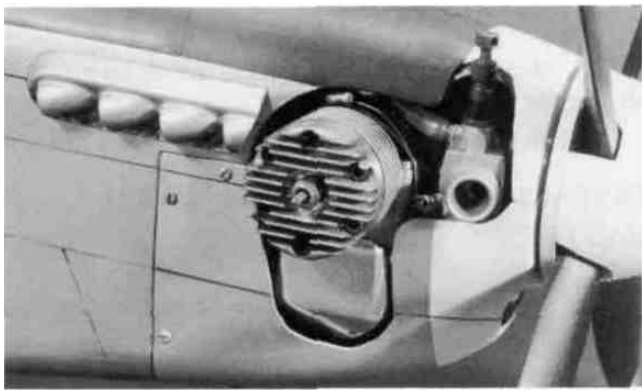

D 3. By trial and error, cut openings in the cowl for the engine head, needle valve and exhaust pipes, etc., as needed. Allow approximately 1/8" clearance all around the engine head for cooling air flow. While fitting, if you notice that the cowl is a poor fit at F-1, you may sand all around the front of the fuse, and along the sides of the upper cowl structure until the cowl fits nicely.

IMPORTANT: If you have installed a 2-cycle engine inverted, with the entire engine head concealed inside the cowl, you must open up the front of the cowl to provide plenty of cooling air flow to the engine head; and, **even more important**, you must provide a large hole in the bottom of the cowl at the firewall for the warm air to exit. This hole should be at least twice the area of the intake **hole**.



D 4. Trim the cowl to match the fuselage and the spinner ring, as shown in the photos.

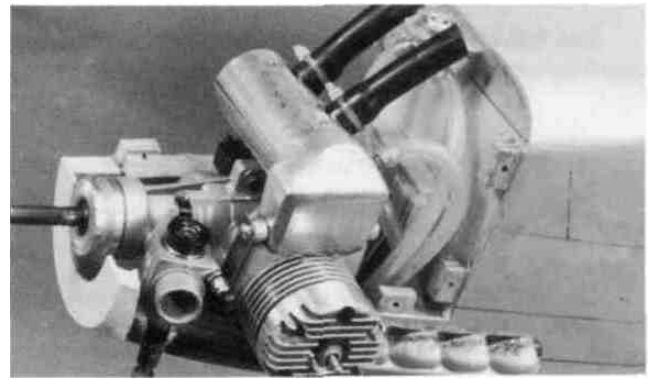
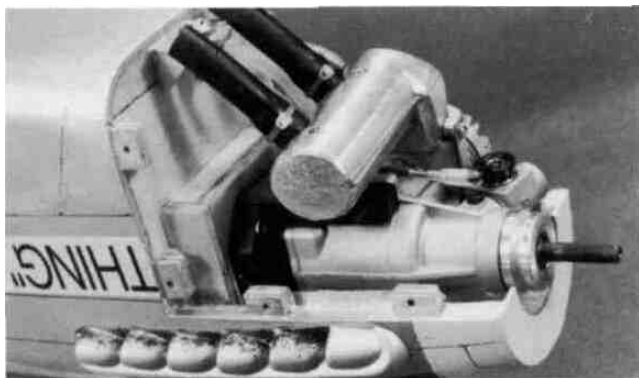

D 5. To attach the cowl to the fuselage, use the 1/4" x 1/2" x 3/4" plywood **cowl mounting blocks**. Glue these blocks to the fuselage and the upper cowl structure in appropriate locations. Inset these blocks approximately 1/32" to allow for the thickness of the cowl. Holding the cowl accurately in position, drill 1/16" holes through the cowl and blocks at the screw locations. Enlarge the holes in the cowl to 3/32".

D 6. Reinforce the cowl at the screw locations by gluing 1" x 1" squares of fiberglass tape to the inside of the cowl. This will help prevent stress cracks in the cowl due to vibration.

D 7. Sand the entire outside surface of the cowl lightly with 320-grit sandpaper.

D 8. Spray paint the cowl with paint to match your covering material. On our prototype we used Chevron spray aluminum and spray yellow. Be sure to allow plenty of time for the paint to dry thoroughly.

FINISHING

ADDITIONAL FUELPROOFING

If you have not already done so, make sure the entire engine compartment is completely fuelproof. Also fuelproof any wood that will not be covered and which may be exposed to glow fuel residue. Use epoxy thinned with alcohol, polyester finishing resin or fuelproof paint.

BALANCE THE AIRPLANE LATERALLY

SPECIAL NOTE: Do not confuse this procedure with "checking the C.G." or "balancing the airplane fore and aft". That very important step will be covered later in the manual.

Now that you have the basic airframe nearly completed, this is a good time to balance the airplane laterally (side-to-side). Here is how to do it:

D 1. Temporarily attach the wing and engine (with muffler) to the fuselage.

D 2. With the wing level, lift the model by the engine propeller shaft and the bottom of the rudder (this may require two people). Do this several times.

D 3. If one wing always drops when you lift, it means that side is heavy. Balance the airplane by gluing weight to the other wing tip. **NOTE: An airplane that has been laterally balanced will track better in loops and other maneuvers.**

FINAL SANDING

Nearly every imperfection in your wood structure will show through the covering material; therefore, before covering, you should make a final check of the entire structure. Fix any "dings," then sand the entire structure smooth using progressively finer grades of sandpaper.

COVERING

Because it is assumed that you have had some previous model building experience, we won't go into detail in regard to the covering procedure. Follow the instructions included with your covering material.

NOTE: When covering the fin and stab, begin by applying 1/2" wide strips of covering in the corners between the fin and stab, and (on the bottom of the stab) between the stab and the fuse sides. Next, cover the stab and fin with pre-cut pieces that have a straight edge to overlap (1/8"+ overlap) the strips you previously applied. **DO NOT, under any circumstances, attempt to cut the covering material after it has been applied to the fin and stab, except around the leading and trailing edges and the tip.** Modelers who do this often cut through the covering and part-way into the balsa stab. This can weaken the stab to the point where it may fail in flight!

The P-51D Mustang prototype was first covered completely with Super Monokote aluminum (with the exception of the rudder). Next, the aluminum was carefully cut away in the areas of the black and white "invasion stripes" and the anti-glare panel on the top front of the fuselage.

Recommended Covering Sequence:

1. 1/2" Strips as described in above note
2. Rudder left side
3. Rudder right side
4. Bottom of elevators
5. Top of elevators
6. Stab bottom
7. Stab top
8. Fuse bottom
9. Wing fillets*
10. Fuse sides
11. Fuse top
12. Fin left side
13. Fin right side
14. Ends of ailerons
15. Bottom of ailerons
16. Top of ailerons
17. Aileron openings in wing
18. Scoop and fairings (on bottom of wing)
19. Bottom of left wing panel
20. Bottom of right wing panel
21. Top of left wing panel (overlap covering 1/4" at wing LE)
22. Top of right wing panel (overlap covering 1/2" at the center and 1/4" at the LE)

*When covering concave surfaces, follow the iron with a damp cloth, pressing the covering down.

GLUE THE HINGES

NOTE: Here is the recommended general sequence for installing the elevator, rudder and hinges...

- A. Attach elevators to stab with hinges.
- B. Install a small 1/4" balsa **filler** behind the elevator, leaving room for unobstructed movement of the 1/8" wire elevator connector.
- C. Cover the filler with covering material, and add fuelproofing if necessary.
- D. Attach rudder to fin with hinges, and install the tailgear at the same time.

D 1. Lay the rudder, elevators and ailerons on the plans and mark on the leading edge of each part the locations of the hinges, torque rods and tailgear. Now use a sharp Xacto knife to cut slits in the covering at the hinge locations. Trial fit the hinges to make sure you have "found" the slots which you previously cut. In the same manner, slit the covering at the hinge locations in the wing, stab and fin TE. Also cut the covering away from the torque rod and tailgear slots.

D 2. The proper method for installing the "Laminated Hinges" is as follows (elevator is used as an example):

1. Slide all hinges halfway into the elevator hinge slots, then insert the hinges into the hinge slots in the stabilizer.
2. Adjust the position of the elevators so they match the stab at the tips. Pull the elevators away from the stab a tiny bit (approximately 1/64", or the thickness of 4 sheets of paper).
3. Verify that the elevators will move up and down without binding.
4. With a pointed applicator tip, apply several drops of thin CA glue to the top and bottom of each hinge.
5. Using a folded tissue, immediately absorb any excess CA glue that may have gotten onto the covering material.
6. After the glue hardens, the elevators will seem quite stiff. Working the elevators fully up and down several times will loosen them up.

D 3. Cut and install a filler block (from scrap 1/4" balsa) behind the elevator joiner wire, between the bottom of the fin and the top of the fuselage.

D 4. Using coarse sandpaper, roughen the part of the aileron torque rods that will be glued into the ailerons, then clean off the sanded portion of the rods with alcohol or a degreasing solvent. Roughen and clean the tailgear wire in the same manner. Using a toothpick, apply a small amount of Vaseline where the torque rods and tailgear wire enter the nylon bearing tubes (to prevent glue from getting inside and locking them up).

D 5. Using a small stick, work a generous amount of epoxy into the tailgear hole in the rudder and the tailgear bearing slot in the aft end of the fuselage, push the rudder and rudder hinges into place and wipe off all excess epoxy. Now carefully position the rudder with respect to the fin, and glue the hinges with thin CA, in the same manner as the elevator hinges.

D 6. Using a small stick, work a generous amount of epoxy into the aileron torque rod holes. Push the ailerons and aileron hinges into place and wipe off all excess epoxy. Now carefully position the ailerons with respect to the wing, and glue the hinges with thin CA, in the same manner as the elevator hinges.

APPLY DECALS AND TRIM

NOTE: The decal sheet does not give you everything you need to completely trim your model; but it does provide all the intricate detailing and difficult items. **The complete trim layout of our prototype is shown on the back of the fuselage plan.**

On our prototypes, the black and white invasion stripes for the wing were made up in advance, using straight strips of Super Monokote with 1/4" overlaps*, then applied to the wing as a unit. The invasion stripes for the fuselage were applied one stripe at a time (see the pattern for this on the trim plan). *When overlapping Monokote, set the iron at low heat when first tacking everything together, then turn up the heat and go over the joints to insure a strong bond at the overlaps.

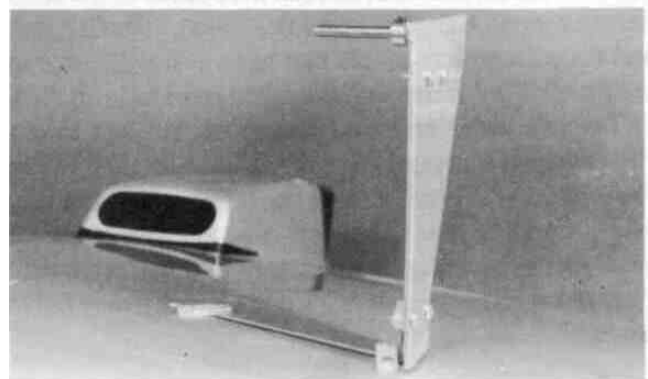
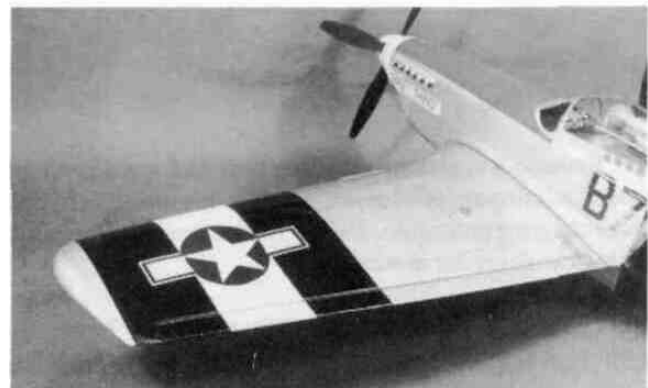
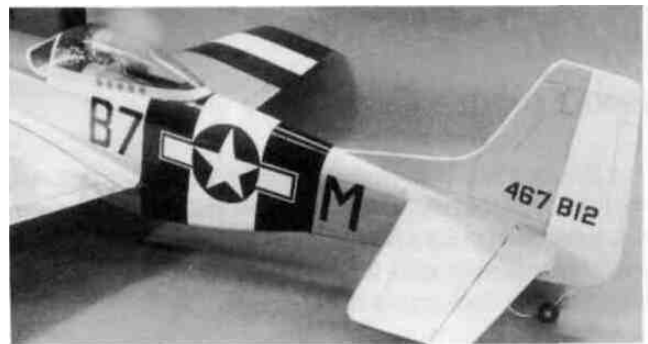

D 1. Study the plans and the photos on the box to determine where to place the decals.

D 2. Thoroughly clean your airplane before applying decals.

D 3. Cut out the individual decal items and apply them in the locations shown on the plan. **NOTE:** Certain non-scale decals are provided which you may use at your discretion, such as the "Great Planes" logo.

HINT: To apply decals accurately, peel only a small portion of backing from one end, cut off the backing with a scissors, position the decal carefully, press down the exposed portion of the decal, peel off the rest of the backing, then (working from the already stuck down end) carefully press down the rest of the decal.

D 4. The top of the fuselage in front of the canopy was covered with Super Monokote "Olive Drab". The Monokote is glossy, and this is supposed to be a non-glare panel; therefore, we masked and sprayed the olive drab monokote with Chevron flat satin, which provided a great-looking flat finish.

D 5. Chevron spray aluminum and spray yellow paints were used on the cowl, and these provided a satisfactory match to the Super Monokote. (The canopy frame may be masked and painted before or after gluing the canopy in place).

D 6. For drawing the "panel lines," we used a "Staedtler Lumocolor 313 Permanent" fine point pen, which is available from engineering/drafting supply stores. Although not completely fuelproof, we like using this pen because it draws very nicely on Monokote, and the lines may be removed if necessary with 70% rubbing alcohol. The plane may be cleaned with most cleaners without affecting the lines, however.

D 7. Trim away the excess plastic from the "wing cannons" and the "exhaust ports," and paint them to match your covering material. (We used Chevron spray aluminum). Glue these trim items to the airplane in the locations shown on the plan.

D 8. Note that some of the promotional photos for this airplane show a 4-blade propeller. We made this propeller by simply gluing two 14" wood props together at a 90-degree angle. The hub section of each prop was cut out halfway, so the two props would mate at the center. This prop is for static display only, as it would not be safe to run the engine with a "homemade" propeller of this type. Only run your engine with a commercially available propeller.

INSTALL PILOT

Assemble and paint your pilot figure, and glue it to the cockpit floor. **NOTE:** To avoid the possibility of the pilot

coming loose inside the canopy, we recommend that you drill up through the cockpit floor and pilot base, and use two #6 or #8 sheet metal screws (not included) to lock the pilot in place.

GLUE CANOPY IN PLACE

D 1. Using a scissors, carefully cut the canopy along the trim line (which is the bolder line around the base of the canopy).

D 2. Lightly sand the inside of the canopy around the edge (sand a strip approximately 1/8" wide). **NOTE:** To avoid sanding more than you want, it is helpful to first apply strips of masking tape on the inside of the canopy, 1/8" in from the edges.

D 3. Poke pinholes (1/8" apart) through the covering material in the area where the canopy will be glued to the fuselage.

D 4. Hold the canopy in place on the fuselage and very carefully apply medium viscosity CA glue around the edges. To control the amount of CA, it is very helpful to use the small diameter teflon applicator tubing which is supplied with most CA glues, or use a "Z-End" applicator tip.



D 5. The unsightly glue that is visible now will be hidden when you paint the framework of the canopy.

WING SEATING

D 1. Apply 1/4" or 3/8" wide foam wing seating tape to the wing saddle area to seal the wing/fuse joints.*

D 2. Also apply a couple pieces of the foam tape to the 1/4" ply wing hold-down plate, which helps to distribute the load when the nylon bolts are tightened.

***NOTE:** An alternate method of sealing the wing/fuse joint is to use "silicone bathtub sealer". This is an excellent method, used by many experts because it results in a permanent and nearly perfect wing saddle joint. Briefly, the technique is as follows: 1. Cover the top of the wing center section with waxed paper or plastic kitchen wrap. Pull out all wrinkles and tape it to the wing. 2. Squeeze out a bead of silicone sealer onto the wing saddle area of the fuselage. 3. Lay the wing in the saddle and push down gently. The excess silicone sealer will

squeeze out. 4. Allow to dry without disturbing for **at least 24 hours**. 5. Remove the tape, then remove the wing from the saddle (leaving the waxed paper or plastic wrap in place). 6. Gently pull the waxed paper or plastic wrap away from the sealer. 7. Using a new single-edge razorblade, trim the sealer flush with the wing fillets, and along the inside of the fuselage.

RE-INSTALL ENGINE & RADIO

Re-install the engine, propeller, battery, receiver, servos, control horns, pushrods, main LG, and **wheels**. Attach the wing to the fuselage.

BALANCE YOUR MODEL

NOTE: This section is VERY important and must not be omitted! A model that is not properly balanced will be unstable and possibly unflyable.

D 1. Accurately mark the balance point on the **top** of the wing on both sides of the fairing. The balance point is shown on the plan (CG), and is located approximately 5-3/8 **inches** back from the leading edge at the center (5/8-inch back from the center of the spar). This is the balance point at which your model should balance for your first flights. Later, you may wish to experiment by shifting the balance up to **5/16" forward or back** to change the flying characteristics. Moving the balance **forward** may improve the smoothness and arrow-like tracking, but it may then require more speed for takeoff and make it more difficult to slow down for landing. Moving the balance **aft** makes the model more agile with a lighter and snappier "feel" and often improves knife-edge capabilities. In any case, **do not balance your model outside the recommended range.**

D 2. With the wing attached to the fuselage, all parts of the model installed (ready to fly), and an **empty** fuel tank, hold the model upside down with the stabilizer level.

D 3. Lift the model at the CG marks. If the tail drops when you lift, the model is "tail heavy" and you must add weight* to the nose to balance. If the nose drops, it is "nose heavy" and you must add weight* to the tail to balance. **NOTE:** Nose weight may be easily installed by using a Prather "Spinner Weight" (available in assorted weights, up to 2 ounces), or by gluing strips of lead into the engine compartment under the engine. Tail weight may be added by using Prather "stick-on" lead weights, and, later, if the balance proves to be OK you can open the fuse bottom and glue these in permanently.

*If possible, first attempt to balance the model by changing the position of the servos and receiver battery. If you are unable to obtain good balance by doing so, **then** it will be necessary to add weight to the nose or tail to achieve the proper balance point.

NOTE: Now that you have the servos located in a position that allows the model to balance at the recommended C.G., you may now securely glue the servo rails and servo rail locking plates to the fuselage sides. Refer back to the section on radio installation, and finish hooking up the pushrods as per the instructions.

FINAL HOOKUPS AND CHECKS

D 1. Make sure the control surfaces move in the proper direction as illustrated in the following sketches:

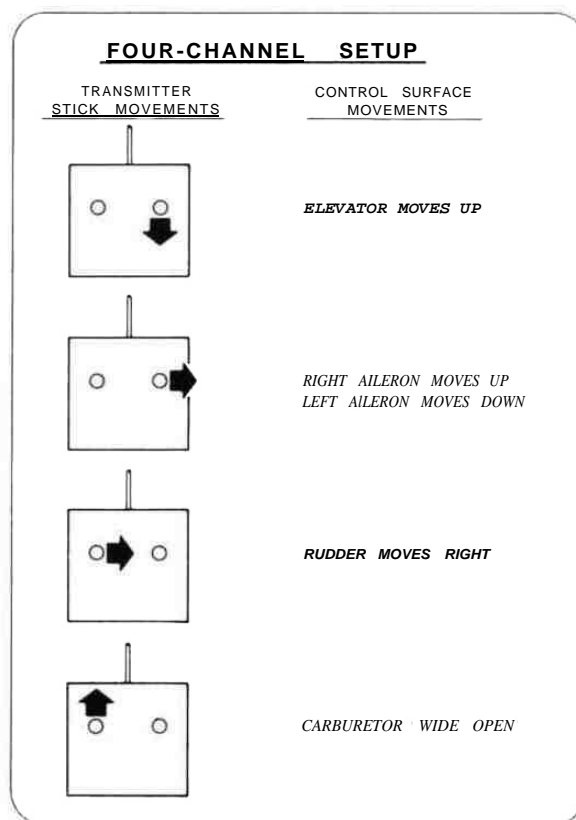

D 2. Adjust your pushrod hookups as necessary to provide the proper control surface movements as listed on Page 39.

D 3. Check for wing twist as follows:

NOTE: Even if you have built your wing on a perfectly flat surface and used utmost care, it is possible that your wing may have a twist due to uneven shrinking of the covering material. **You must check for this condition and correct it before the first flight.**

If you do not own a **wing incidence meter**, we recommend that you purchase one from your local hobby dealer or borrow one from another modeler. With the wing mounted to the fuselage, use the incidence meter to check the angle of your wing at the root and at the tips. If the incidence meter reveals a wing twist of more than 1/4 degree, you must grasp the wing at the tip and twist it slightly, while reheating the covering material. Keep checking, twisting and reheating until the wing twist is removed. **NOTE:** If you have corrected a wing twist by this method, you should periodically re-check to make sure the correction has held.

PRE-FLIGHT

CHARGE THE BATTERIES

Follow the battery charging procedures in your radio instruction manual. You should **always** charge your transmitter and receiver batteries the night before you go flying, and at other times as recommended by the radio manufacturer.

FIND A SAFE PLACE TO FLY

The best place to fly your R/C model is an AMA (Academy of Model Aeronautics) chartered club field. Ask your hobby shop dealer if there is such a club in your area and join. Club fields are set up for R/C flying which makes your outing safer and more enjoyable. The AMA can also tell you the name of a club in your area. We recommend that you join AMA and a local club so you can have a safe place to fly and also have insurance to cover you in case of a flying accident. (The AMA address is listed on the front cover of this instruction book).

If a club and its flying site are not available, you need to find a large, grassy area at least 6 miles away from any other R/C radio operation like R/C boats and R/C cars and away from houses, buildings and streets. A schoolyard may look inviting but it is too close to people, power lines and possible radio interference.

GROUND CHECK THE MODEL

If you are not thoroughly familiar with the operation of R/C models, ask an experienced modeler to check to see that you have the radio installed correctly and that all the control surfaces do what they are supposed to. The engine operation must also be checked and the engine "broken in" on the ground by running the engine for at least two tanks of fuel. **Follow the engine manufacturer's recommendations for break-in.** Check to make sure all screws remain tight, that the hinges are secure and that the prop is on tight.

RANGE CHECK YOUR RADIO

Wherever you do fly, you need to check the operation of the radio before every time you fly. This means with the transmitter antenna collapsed and the receiver and transmitter on, you should be able to walk at least 100 feet away from the model and still have control. Have someone help you. Have them stand by your model and, while you work the controls, tell you what the various control surfaces are doing.

Repeat this test **with the engine running** at various speeds with an assistant holding the model. If the control surfaces are not acting correctly at all times, **do not fly!** Find and correct the problem first.

ENGINE SAFETY PRECAUTIONS

NOTE: Failure to follow these safety precautions may result in severe injury to yourself and others.

Keep all engine fuel in a safe place, away from high heat, sparks or flames, as fuel is very flammable. Do not smoke near the engine or fuel; remember that the engine exhaust gives off a great deal of deadly carbon monoxide. Therefore **do not run the engine in a closed room or garage.**

Get help from an experienced pilot when learning to operate engines.

Use safety glasses when starting or running engines.

Do not run the engine in an area of loose gravel or sand; as the propeller may throw such material in your face or eyes.

Keep your face and body as well as all spectators away from the plane of rotation of the propeller as you start and run the engine.

Keep items such as these away from the prop: loose clothing, shin sleeves, ties, scarfs, long hair or loose objects

(pencils, screw drivers) that may fall out of shut or jacket pockets into the prop.

Use a "chicken stick" device or electric starter; follow instructions supplied with the starter or stick. Make certain the glow plug clip or connector is secure so that it will not pop off or otherwise get into the running propeller.

Make all engine adjustments from **behind** the rotating propeller.

The engine gets hot! Do not touch it during or after operation. Make sure fuel lines are in good condition so fuel is not leaked onto a hot engine causing a fire.

To stop the engine, cut off the fuel supply by closing off the fuel line or follow the engine manufacturer's recommendations. Do not use hands, fingers or any body part to try to stop the engine. Do not throw anything into the prop of a running engine.

AMA SAFETY CODE

Read and abide by the following Academy of Model Aeronautics Official Safety Code:

GENERAL

1. I will not fly my model aircraft in competition or in the presence of spectators until it has been proven to be airworthy by having been previously successfully flight tested.
2. I will not fly my model aircraft higher than approximately 400 feet within 3 miles of an airport without notifying the airport operator. I will give right of way to, and avoid flying in the proximity of full scale aircraft. Where necessary an observer shall be utilized to supervise flying to avoid having models fly in the proximity of full scale aircraft.
3. Where established, I will abide by the safety rules for the flying site I use, and I will not willfully and deliberately fly my models in a careless, reckless and/or dangerous manner.

RADIO CONTROL

1. I will have completed a successful radio equipment ground check before the first flight of a new or repaired model.
2. I will not fly my model aircraft in the presence of spectators until I become a qualified flyer, unless assisted by an experienced helper.
3. I will perform my initial turn after takeoff away from the pit, spectator and parking areas, and I will not thereafter perform maneuvers, flights of any sort or landing approaches over a pit, spectator or parking area.

FLYING

The Great Planes P-51D Mustang is a great flying sport scale airplane that flies smoothly and predictably, yet is highly maneuverable. It does not have the self-recovery characteristics of a primary trainer, therefore you must either have mastered the basics of R/C flying or seek the assistance of a competent R/C pilot to help you with your first flights.

TAKEOFF: If you have dual rates on your transmitter, set the switches to "high rate" for takeoff, especially when taking off in a crosswind. Although this P-51D has great low speed characteristics, you should always build up as much speed as your runway will permit before lifting off, as this will give you a safety margin in case of a "flame-out". When you first advance the throttle and the tail begins to lift, the plane will start to turn left (a characteristic of all "taildraggers)". Be ready for this, and correct by applying sufficient right rudder to hold it straight down the runway. The left-turning-tendency will

plane picks up speed. When the plane has sufficient flying speed, lift off by smoothly applying a little up elevator (don't "jerk" it off to a vertical climb'), and climb out gradually.

FLYING: We recommend that you take it easy with your P-51D Mustang for the first several flights and gradually "get acquainted" with this fantastic ship as your engine gets fully broken-in. Add and practice one maneuver at a time, learning how she behaves in each one. For ultra-smooth flying and normal maneuvers, we recommend using the "low rate" settings as listed on page 39. "High rate" elevator and rudder may be required for crisp snap rolls and spins. "Low rate" rudder is best for knife edge. If you notice any "sluggishness" in the way your P-51D handles, it is probably a result of not enough speed, in which case you should install a propeller with increased pitch. Do not exceed the recommended "high rate" throws for the rudder, as this will only result in pitch-down when full rudder is applied. Speed is the key to good knife-edge performance.

LANDING: When it's time to land, fly a normal landing pattern and approach. If you find that it lands a little fast, you might try dialing in a few clicks of up elevator when you cut the throttle on the downwind leg of the landing pattern. This will automatically help to bleed off some of the speed. If your P-51 D is built straight and true, you'll find that you can really flare it out for slow, nose-high, full-stall landings without fear of tip stalling.

CAUTION (THIS APPLIES TO ALL R/C AIRPLANES): If, while flying, you notice any unusual sounds, such as a low-pitched "buzz", this may be an indication of control surface "flutter". Because flutter can quickly destroy components of your airplane, any time you detect flutter you must **immediately** cut the throttle and land the airplane! Check all servo grommets for deterioration (this will indicate which surface fluttered), and make sure all pushrod linkages are slop-free. If it fluttered once, it will probably flutter again under similar circumstances unless you can eliminate the slop or flexing in the linkages. Here are some things which can result in flutter: Excessive hinge gap; Not mounting control horns solidly; Sloppy fit of clevis pin in horn; Elasticity present in flexible plastic pushrods; Side-play of pushrod in guide tube caused by tight bends; Sloppy fit of Z-bend in servo arm; Insufficient glue used when gluing in the elevator joiner wire or aileron torque rod; Excessive flexing of aileron, caused by using too soft balsa aileron; Excessive "play" or "backlash" in servo gears; and Insecure servo mounting.

Have a ball! But always stay in control and fly in a safe manner.

GOOD LUCK AND GREAT FLYING!

SEE THE FULL LINE OF GREAT PLANES AIRPLANES AT YOUR HOBBY DEALER.

WE HOPE YOU WILL SELECT ANOTHER "GREAT PLANE" AS YOUR NEXT PROJECT. THANK YOU!

FLIGHT TRIMMING

... A model is not a static object. Unlike a car, which can only hunt left or right on the road (technically, a car does yaw in corners, and pitches when the brakes are applied), a plane moves through that fluid we call air in all directions simultaneously. The plane may look like it's going forward, but it could also be yawing slightly, slipping a little and simultaneously climbing or diving a bit! The controls interact. Yaw can be a rudder problem, a lateral balance problem or an aileron rigging problem. We must make many flights, with minor changes between each, to isolate and finally correct the problem.

The chart accompanying this article is intended to serve as a handy field reference when trimming your model. Laminate it in plastic and keep it in your flight box. You just might have need to consult it at the next contest! The chart is somewhat self-explanatory, but we will briefly run through the salient points.

First, we are assuming that the model has been C.G. balanced according to the manufacturer's directions. There's nothing sacred about that spot - frankly, it only reflects the balance point where a prototype model handled the way the guy who designed it thought it should. If your model's wing has a degree more or less of incidence, then the whole balance formula is incorrect for you. But, it's a good ballpark place to start.

The second assumption is that the model has been balanced laterally. Wrap a strong string or monofilament around the prop shaft behind the spinner, then tie the other end to the tail wheel or to a screw driven into the bottom of the aft fuse. Make the string into a bridle harness and suspend the entire model inverted (yes, with the wing on!). If the right wing always drops, sink some screws or lead into the left wing tip, etc. You may be surprised to find out how much lead is needed.

At this point the model is statically trimmed. It's only a Starting point, so don't be surprised if you wind up changing it all. One other critical feature is that the ailerons must have their hinge gap sealed. If shoving some Scotch tape or Monokole into the hinge gap to prevent the air from slipping from the top of the wing to the bottom, and vice-versa, bothers you, then don't do it.

To achieve the maximum lateral trim on the model, the hinge gap on the ailerons should be sealed. The easiest way to do this is to disconnect the aileron linkages, and fold the ailerons as far over the top of the wing as possible (assuming they are top or center hinged). Apply a strip of clear tape along the joint line. When the aileron is returned to neutral, the tape will be invisible, and the gap will be effectively sealed. Depending on how big the ailerons are, and how large a gaping gap you normally leave when you install hinges, you could experience a 20 percent increase in aileron control response just by this simple measure.

... Your first flights should be to ascertain control centering and control feel. Does the elevator always come back to neutral after a 180-degree turn or Split-S? Do the ailerons tend to hunt a little after a rolling maneuver? Put the plane through its paces. Control centering is either a mechanical thing (binding servos, stiff linkages, etc.), an electronic thing (bad servo resolution or dead-band in the radio system), or C.G. (aft Center of Gravity will make the plane wander a bit). The last possibility will be obvious, but don't continue the testing until you have isolated the problem and corrected it.

... let's get down to the task of trimming the model. Use the tachometer every time you start the engine, to insure consistent results. These trim flights must be done in calm weather. Any wind will only make the model weathervane. Each "maneuver" on the list assumes that you will enter it dead straight-and-level. The wings must be perfectly flat, or else the maneuver will not be correct and you'll get a wrong interpretation. That's where your observer comes in. Instruct him to be especially watchful of the wings as you enter the maneuvers

Do all maneuvers at full throttle. The only deviation from this is if the plane will be routinely flown through maneuvers at a different power setting...

Let's commence with the "engine thrust angle" on the chart. Note that the observations you make can also be caused by the C.G., so be prepared to change both to see which gives the desired result. Set up a straight-and-level pass. The model should be almost hands-off. Without touching any other control on the transmitter, suddenly chop the throttle. Did the nose drop? When you add power again, did the nose pitch up a bit? If so, you need some downthrust, or nose weight. When the thrust is correct, the model should continue along the same flight path for at least a dozen plane lengths before gravity starts to naturally bring it down.

Do each maneuver several times, to make sure that you are getting a proper diagnosis. Often, a gust, an accidental nudge on the controls, or just a poor maneuver entry can mislead you. The thrust adjustments are a real pain to make. On most models, it means taking the engine out, adding shims, then reassembling the whole thing. Don't take shortcuts. Don't try to proceed with the other trim adjustments until you have the thrust line and/or C.G. correct. They are the basis upon which all other trim settings are made.

Also, while you have landed, take the time to crank the clevises until the transmitter trims are at neutral. Don't leave the airplane so that the transmitter has some odd-ball combination of trim settings. One bump of the transmitter and you have lost everything. The trim must be repeatable, and the only sure way to do this is to always start with the transmitter control trims at the middle.

The next maneuver is somewhat more tricky than it looks. **To** verify the C.G., we roll the model up to a 45-degree bank, then take our hands off the controls. The model should go a reasonable distance with the fuse at an even keel. If the nose pitches down, remove some nose weight, and the opposite if the nose pitches up. The trick is to use only the ailerons to get the model up at a 45-degree bank. We almost automatically start feeding in elevator, but that's a no-no. Do the bank in both directions, just to make sure that you are getting an accurate reading of the longitudinal balance.

We now want to test the correct alignment of both sides of the elevator (even if they aren't split, like a Pattern ship's, they can still be warped or twisted). Yaw and lateral balance will also come into play here, so be patient and eliminate the variables, one-by-one. The maneuver is a simple loop, but it must be entered with the wings perfectly level. Position the maneuver so that your assistant can observe it end-on. Always loop into the wind. Do several loops, and see if the same symptom persists. Note if the model loses heading on the front or back side of the loop. If you lose it on the way up, it's probably an aileron problem, while a loss of heading on the way back down is most likely a rudder situation.

After you get the inside loops going correctly, do the same maneuver to the outside, entering from an inverted position ... Before you make too many dramatic changes, glance at the

remainder of the chart and note the myriad combination of things **we** can do just with the ailerons. Each change you make will affect all other variables!

Note that the Yaw test is the same looping sequences. Here, however, we are altering rudder and ailerons, instead of the elevator halves. We must repeat that many airplanes just will not achieve adequate lateral trim without scaling the hinge gaps shut. The larger you make the loops (to a point), the more discernable the errors will be.

The Lateral Balance test has us pulling those loops very tightly. Actually, we prefer the Hammerhead as a better test for a heavy wing. Pull straight up into a vertical and watch which wing drops. A true vertical is hard to do, so make sure that your assistant is observing from another vantage point. Note that the engine torque will affect the vertical fall off, as will rudder errors. Even though we balance the wing statically before leaving for the field, we are now trimming it dynamically.

The Aileron Coupling (or rigging) is also tested by doing Hammerheads. This time, however, we want to observe the side view of the model. Does the plane want to tuck under a bit? If so, then try trimming the ailerons down a small bit, so that they will act as Raps. If the model tends to want to go over into a loop, then rig both ailerons up a few turns on the clevises. Note that drooping the ailerons will tend to cancel any washout you have in the wing. On some models, the lack of washout can lead to some nasty characteristics at low speeds.

The effects noted with the Aileron Coupling tests can also be caused by an improperly set wing incidence. The better test for this is knife-edge flight. If the model tends to pull upward, i.e., it swings toward a nose up direction, then reduce the wing incidence. If the model tries to go off heading toward the bottom side of the plane, then increase incidence.

Again, we reiterate that all of these controls are interactive. When you change the wing incidence, it will influence the way the elevator trim is at a given C.G. Re-trimming the wing will also change the rigging on the ailerons, in effect, and they may have to be readjusted accordingly.

The whole process isn't hard. As a matter of fact it's rather fun—but very time consuming. It's amazing what you will learn about why a plane flies the way it does, and you'll be a better pilot for it. One thing we almost guarantee, is that your planes will be more reliable and predictable when they are properly trimmed out. They will fly more efficiently, and be less prone to doing radical and surprising things. Your contest scores should improve, too.

We wish to acknowledge the Orlando, Florida, club newsletter, from which the basics of the chart presented here were gleaned.

Reprinted in part by Great Planes Model Manufacturing Company, courtesy of Scale R/C Modeler magazine. Pat Potega, Editor, August, 1983 issue.

FLIGHT TRIMMING CHART

TRIM FEATURE	MANEUVERS	OBSERVATIONS	CORRECTIONS
CONTROL CENTERING	Fly general circles and random maneuvers.	Try for hands off straight and level flight.	Readjust linkages so that Tx trims are centered.
CONTROL THROWS	Random maneuvers.	A. Too sensitive, jerky controls B. Not sufficient control	If A, change linkages to reduce throws If B, increase throws.
ENGINE THRUST ANGLE ¹	From straight flight, chop throttle quickly.	A Aircraft continues level path for short distance. B. Plane pitches nose up C. Plane pitches nose down.	If A, trim is okay. If B, decrease downthrust. If C, increase downthrust.
CENTER OF GRAVITY LONGITUDINAL BALANCE	From level flight roll to 45-degree bank and neutralize controls.	A Continues in bank for moderate distance. B Nose pitches up C Nose drops.	If A, trim is good. If B, add nose weight. If C, remove nose weight.
SPLIT ELEVATORS (Also Yaw and C.G.)	Into wind, pull open loops, using only elevator Repeat tests doing outside loops to inverted entry.	A. Wings are level throughout B. Plane tends toward outside when right side up, and to inside when inverted C Plane goes in on regular loops and out on inverted. D Plane goes out on both types of loops E Plane goes in on both types of loops	If A, trim is "fine" If B, add weight to right wing, or add right rudder. If C, add weight to left wing, or add left rudder. If D, raise right half of elevator (or lower left). If E, raise left half of elevator (or lower right).
YAW	Into wind, do open loops, using only elevator. Repeat tests doing outside loops from inverted entry	A Wings are level throughout. B Yaws to right in both inside and outside loops. C Yaws to left in both inside and outside loops D Yaws right on insides, and left on outside loops E Yaws left on insides, and right on outside loops	If A, trim is correct If B, add left rudder trim If C, add right rudder trim If D, add left aileron trim. If E, add right aileron trim.
LATERAL BALANCE	Into wind, do tight inside loops, or make straight up climbs into Hammerheads Do same from inverted entry	A. Wings are level and plane falls to either side randomly in Hammerhead. B Falls off to left in both inside and outside loops. Worsens as loops lighten C Falls off to right in both loops Worsens as loops tighten D Falls off in opposite directions on inside and outside loops	If A, trim is correct. If B, add weight to right wing tip If C, add weight to left wing tip. If D, change aileron trim ³
AILERON RIGGING	With wings level, pull to vertical climb and neutralize controls.	A Climb continues along same path. B Nose tends to go to inside loop C Nose tends to go to outside loop	If A, trim is correct If B, raise both ailerons very slightly If C, lower both ailerons very slightly
WING INCIDENCE	Knife edge flight.	A Models tends to veer in nose up direction B Model veers in nose down direction	If A, reduce wing incidence. If B, increase wing incidence.

1. Engine thrust angle and C G interact Check both

2. Yaw and lateral balance produce similar symptoms Note that fin may be crooked Right and left references are from the plane's vantage point

3. Ailerons cannot always be trimmed without sealing the hinge gap.

3-VIEW DRAWING

