

PIPER J-3 CUB

INSTRUCTION MANUAL



Wingspan (Standard): 76.5 in [1,945mm]

Wingspan (Clipped): 61.5 in [1,560mm]

Wing Area (Standard): 820 sq in [58.9dm²]

Wing Area (Clipped): 653 sq in [42.1dm²]

Weight: 6.5-7.5 lbs [2950-300g]

Wing Loading: 18-21 oz/sq ft [55-64g/dm²]

Length: 49 in [1,245mm]

Radio: 4-channel transmitter with 4 standard servos

Engine: .40-.61 cu. in. [6.5-10cc] two-stroke

.48-.80 cu. in. [8-13cc] four-stroke

WARRANTY

Great Planes® Model Manufacturing Co. guarantees this kit to be free from defects in both material and workmanship at the date of purchase. This warranty does not cover any component parts damaged by use or modification. **In no case shall Great Planes' liability exceed the original cost of the purchased kit.** Further, Great Planes reserves the right to change or modify this warranty without notice.

In that Great Planes has no control over the final assembly or material used for final assembly, no liability shall be assumed nor accepted for any damage resulting from the use by the user of the final user-assembled product. By the act of using the user-assembled product, the user accepts all resulting liability.

If the buyer is not prepared to accept the liability associated with the use of this product, the buyer is advised to return

this kit immediately in new and unused condition to the place of purchase.

To make a warranty claim send the defective part or item to Hobby Services at the address below:

Hobby Services
3002 N. Apollo Dr. Suite 1
Champaign, IL 61822
USA

Include a letter stating your name, return shipping address, as much contact information as possible (daytime telephone number, fax number, e-mail address), a detailed description of the problem and a photocopy of the purchase receipt. Upon receipt of the package the problem will be evaluated as quickly as possible.

READ THROUGH THIS MANUAL BEFORE STARTING CONSTRUCTION. IT CONTAINS IMPORTANT INSTRUCTIONS AND WARNINGS CONCERNING THE ASSEMBLY AND USE OF THIS MODEL.



Champaign, IL
(217) 398-8970, Ext. 5
airsupport@greatplanes.com

TABLE OF CONTENTS

INTRODUCTION	2
Precautions	3
DECISIONS YOU MUST MAKE	3
Engine Selection	3
Wing Configuration	4
Muffler Selection	4
REQUIRED ITEMS	4
Required Accessories	4
Adhesives & Building Supplies	4
Covering Tools	4
Optional Supplies & Tools	4
IMPORTANT BUILDING NOTES	5
COMMON ABBREVIATIONS	5
TYPES OF WOOD	6
GET READY TO BUILD	6
DIE-CUT PATTERNS	6
TAIL FEATHERS	8
Build the Rudder	8
Build the Fin	9
Build the Stabilizer	9
Build the Elevators	10
Cut the Hinge Slots	11
WING ASSEMBLY	11
Build the Wing Panels	11
Joining the Wing Panels	15
Install the Aileron Linkage	17
Install LE and TE Sheeting	18
Install Center Sheeting	20
Build the Ailerons	21
Install Ailerons	22
FUSELAGE ASSEMBLY	23
Prepare Fuse Parts	23
Assemble Fuselage	25
Install Engine Mount and Fuel Tank	28
Final Fuselage Assembly	29
Mount Stabilizer and Fin	30
Install Main Landing Gear	32
Mount the Wing to the Fuse	33
Install Servos, Horns, and Pushrods	34
Control Throws	35
FINAL ASSEMBLY	35
Install Wing Struts (Optional)	35
Install Receiver, Switch, and Battery	36
Install Cowl	37
Additional Fuelproofing	38
Balance the Airplane Laterally	38
Final Sanding	38
Covering	38
Apply Decals and Trim	39
Glue the Hinges	39
Build the Cockpit Floor (Optional)	39
Painting the Pilot (Optional)	40

Build the Seats (Optional)	40
Build the Landing Gear Suspension (Optional)	40
Build the Dummy Engines	41
Other Scale Details	42
Install the Windshield	42
Install the Side Windows	43
Balance Your Model	43
Final Hookups and Checks	43
PREFLIGHT	44
Charge the Batteries	44
Find a Safe Place to Fly	44
Ground Check the Model	44
Range Check Your Radio	44
Engine Safety Precautions	44
AMA SAFETY CODE	45
FLYING	45
2-VIEW DRAWING	Back Cover

INTRODUCTION

Thank you for purchasing the Great Planes **Piper J-3 Cub!** This **J-3 Cub** kit is a 1/5.5 (18%) scale model of a full-size **J-3 Cub** and retains the real plane's great flying characteristics.

You will find the **J-3 Cub** easy to build and fly, very predictable and fairly aerobatic, yet it has no bad habits. Although the model is sufficiently close to scale that it can place well in sport-scale competition, traditional Great Planes interlocking construction makes it simple to build a great-looking and straight airplane that is sturdy enough to take along every time you go to the flying field.

If you have chosen this kit as your first R/C model, it is important that you find an experienced modeler to help you throughout the building and flying of this plane. He should thoroughly check the plane over before flying it and help you with the first flights. The **J-3 Cub** is a big airplane and lacks the self-recovery characteristics of a good **basic trainer** such as the Great Planes **PT Series** airplanes. On the other hand, if you have already learned the basics of R/C flying and you are able to safely handle a "trainer" airplane, the **J-3 Cub** is an excellent choice.

Scale Model Research has photo sets and drawings of full scale Piper Cubs available. These can help provide good documentation for scale detailing and contests. Their address is 3114 Yukon Avenue, Costa Mesa, CA 92626 and their phone number is (714) 979-8058.

For the latest technical updates or manual corrections to the Piper **J-3 Cub .40**, visit the web site listed below and select the Great Planes Piper **J-3 Cub .40**. If there is new technical information or changes to this kit a "tech notice" box will appear in the upper left corner of the page.

<http://www.greatplanes.com/airplanes/index.html>

**PROTECT YOUR MODEL, YOURSELF
& OTHERS...FOLLOW THESE
IMPORTANT SAFETY PRECAUTIONS**

1. Your Piper J-3 Cub .40 should not be considered a toy, but rather a sophisticated, working model that functions very much like a full-size airplane. Because of its performance capabilities, the Piper J-3 Cub .40, if not assembled and operated correctly, could possibly cause injury to yourself or spectators and damage to property.
2. You must assemble the model **according to the instructions**. Do not alter or modify the model, as doing so may result in an unsafe or unflyable model. In a few cases the instructions may differ slightly from the photos. In those instances the written instructions should be considered as correct.
3. You must take time to build **straight, true and strong**.
4. You must use an R/C radio system that is in first-class condition, and a correctly sized engine and components (fuel tank, wheels, etc.) throughout the building process.
5. You must correctly install all R/C and other components so that the model operates correctly on the ground and in the air.
6. You must check the operation of the model before **every** flight to insure that all equipment is operating and that the model has remained structurally sound. Be sure to check clevises or other connectors often and replace them if they show any signs of wear or fatigue.
7. If you are not already an experienced R/C pilot, you should fly the model only with the help of a competent, experienced R/C pilot.
8. While this kit has been flight tested to exceed normal use, if the plane will be used for extremely high stress flying, such as racing, the modeler is responsible for taking steps to reinforce the high stress points.

We, as the kit manufacturer, provide you with a top quality, thoroughly tested kit and instructions, but ultimately the quality and flyability of your finished model depends on how you build it; therefore, we cannot in any way guarantee the performance of your completed model, and no representations are expressed or implied as to the performance or safety of your completed model.

Remember: Take your time and follow the instructions to end up with a well-built model that is straight and true.

Before starting to build, compare the parts in this kit with the Parts List, and note any missing parts. Also inspect all parts to make sure they are of acceptable

quality. If any parts are missing, broken or defective, or if you have any questions about building or flying this airplane, please contact Great Planes at the address or telephone number below. If you are contacting us for replacement parts, please be sure to provide the full kit name (Piper J-3 Cub .40) and the part numbers as listed in the Parts List.

Great Planes Product Support:
3002 N Apollo Drive, Suite 1
Champaign, IL 61822
Telephone: (217) 398-8970
Fax: (217) 398-7721

E-mail: productsupport@greatplanes.com

You can also check our web site at www.greatplanes.com for the latest Piper J-3 Cub .40 updates.

If you have not flown this type of model before, we recommend that you get the assistance of an experienced pilot in your R/C club for your first flights. If you're not a member of a club, your local hobby shop has information about clubs in your area whose membership includes experienced pilots.

In addition to joining an R/C club, we strongly recommend you join the AMA (Academy of Model Aeronautics). AMA membership is required to fly at AMA sanctioned clubs. There are over 2,500 AMA chartered clubs across the country. Among other benefits, the AMA provides insurance to its members who fly at sanctioned sites and events. Additionally, training programs and instructors are available at AMA club sites to help you get started the right way. Contact the AMA at the address or toll-free phone number below:



Academy of Model Aeronautics

5151 East Memorial Drive
Muncie, IN 47302
Tele: (800) 435-9262
Fax (765) 741-0057
Or via the Internet at:

<http://www.modelaircraft.org>

DECISIONS YOU MUST MAKE

Engine Selection

The engine you select will determine where the throttle pushrod is routed and also how the cowl is cut out, so it is important that you have the engine close at hand while building.

The recommended engine size range is as follows:

.40 - .61 cubic inch displacement **2-cycle**

.48 - .80 cubic inch displacement **4-cycle**

For the best scale effect, an **OS .48 Surpass** 4-cycle is ideal. For maximum aerobatics, an **OS .70 Surpass** 4-cycle is all the power you will need.

This kit includes a Great Planes **EM4070** engine mount that fits most .40 - .60 2-cycle engines and most 40 - .70 4-cycle engines.

Wing Configuration

This kit includes everything you need to build **either** the standard or the clipped wing for your Cub. Both versions fly extremely well and are equally easy to construct. The standard wing makes the Cub a real "Floater" giving you plenty of time to think about your maneuvers. The clipped wing allows things to happen a bit quicker. Snaps, rolls and spins can be performed faster and more precisely. Either way, the model flies much like the real plane.

Muffler Selection

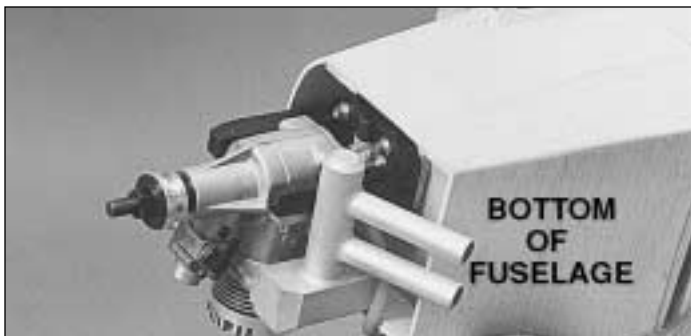

If you install a 2-cycle engine, we recommend using a muffler that can be partially enclosed inside the cowl. The muffler shown in the instruction book photos is a Slimline #3217 Pitts Style Muffler for OS MAX .61SF and .60FP engines. If you use a OS .40SF or .46SF use a Slimline #3218 Pitts Style Muffler or similar. Most standard mufflers will require an extension to clear the fuselage sides.

REQUIRED ITEMS

Required Accessories

- Engine, prop nut, and suitable propellers
- 4-Channel radio with 4 standard servos
- 1/4" [6mm] R/C foam rubber (HCAQ1000)
- 10 or 12 oz. Fuel tank (GPMQ4104 or GPMQ4105)
- 3' [900mm] Standard silicone fuel tubing (GPMQ4131)
- 3-3/8" Main wheels, Cub Style (GPMQ4230)
- 1-1/4" Tail wheel (GPMQ4242)

- (4) 3/16" Wheel Collars (GPMQ4308)
- (2) 3/32" Wheel Collars (GPMQ4302)
- (2) Rolls Top Flite® MonoKote® covering (TOPQ0220, Cub Yellow)

Adhesives & Building Supplies

In addition to common household tools (screwdrivers, drill, etc.), this is the "short list" of the most important items required to build the Piper J-3 Cub .40. *We recommend Great Planes Pro™ CA and Epoxy glue.*

- 2 oz. Thin Pro CA (GPMR6003)
- 2 oz. Medium Pro CA+ (GPMR6009)
- Pro 6-minute epoxy (GPMR6045)
- HobbyLite™ balsa-colored balsa filler (HCAR3401)
- Plan Protector™ (GPMR6167) or wax paper
- Drill bits: 1/16" [1.6mm], 5/64" [2.0mm], 3/32" [2.4mm], 7/64" [2.8mm], 1/8" [3.2mm], 9/64" [3.6mm], 11/64" [4.4mm], 3/16" [4.8mm], 1/4" [6.4mm]
- Small metal file
- Stick-on segmented lead weights (GPMQ4485)
- Silver solder w/flux (GPMR8070)
- #1 Hobby knife (HCAR0105)
- #11 Blades (100-pack, HCAR0311)
- Single-edge razor blades (10-pack, HCAR0212)
- Small T-pins (100, HCAR5100)
- Medium T-pins (100, HCAR5150)
- Sanding tools and sandpaper assortment (see **Expert Tip-Easy-Touch™ Bar Sander** section on page 5)

Covering Tools

- Top Flite® MonoKote® sealing iron (TOPR2100)
- Top Flite MonoKote heat gun (TOPR2000)

Optional Supplies & Tools

Here is a list of optional tools mentioned in the manual that will help you build the Piper J-3 Cub .40.

- Pro Aliphatic resin (2 oz. [60g], GPMR6160)
- 2 oz. [57g] Spray CA activator (GPMR6035)
- CA applicator tips (HCAR3780)
- CA debonder (GPMR6039)
- Epoxy brushes (6, GPMR8060)
- Mixing sticks (50, GPMR8055)
- Mixing cups (GPMR8056)
- Razor plane (MASR1510)
- Builder's triangle set (HCAR0480)
- 36" Metal ruler (HCAR0475)
- Curved-tip canopy scissors (for trimming plastic parts, (HCAR0667)

- Pliers with wire cutter (HCAR0630)
- Robart Super Stand II (ROBP1402)
- 18" x 24" [460 x 610mm] Builder's cutting mat (HCAR0455)
- 16" x 48" [410 x 1220mm] Building board (GPMR6950)
- Masking tape (TOPR8018)
- Threadlocker™ thread locking cement (GPMR6060)
- Denatured alcohol (for epoxy clean up)
- Z-bend pliers (HCAR2000)
- Rotary tool such as Dremel® Moto-Tool®
- Rotary tool reinforced cut-off wheel (GPMR8200)
- Servo horn drill (HCAR0698)
- Dead Center™ Engine Mount Hole Locator (GPMR8130)
- AccuThrow™ Deflection Gauge (GPMR2405)
- Slot Machine™ hinge slotting tool (110V, GPMR4010)
- CG Machine™ (GPMR2400)
- Laser incidence meter (GPMR4020)
- Precision Magnetic Prop Balancer™ (TOPQ5700)

IMPORTANT BUILDING NOTES

- There are two types of screws used in this kit:

Sheet metal screws are designated by a number and a length.



For example #6 x 3/4"

This is a number six screw that is 3/4" long.

Machine screws are designated by a number, **threads per inch**, and a length. **SHCS** is just an abbreviation for "socket head cap screw" and that is a machine screw with a socket head.

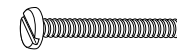

For example 4-40 x 3/4".

This is a number four screw that is 3/4" long with forty threads per inch.

- When you see the term **test fit** in the instructions, it means that you should first position the part on the assembly **without using any glue**, then slightly modify or custom fit the part as necessary for the best fit.

- Whenever the term **glue** is written you should rely upon your experience to decide what type of glue to use. When a specific type of adhesive works best for that step, the instructions will make a recommendation.

- Whenever just **epoxy** is specified you may use **either** 30-minute (or 45-minute) epoxy **or** 6-minute epoxy. When 30-minute epoxy is specified it is **highly** recommended that you use only 30-minute (or 45-minute) epoxy, because you will need the working time and/or the additional strength.

- **Photos** and **sketches** are placed **before** the step they refer to. Frequently you can study photos in following steps to get another view of the same parts.

COMMON ABBREVIATIONS

- Fuse = Fuselage
- Stab = Horizontal Stabilizer
- Fin = Vertical Fin
- LE = Leading Edge
- TE = Trailing Edge
- LG = Landing Gear
- Ply = Plywood
- " = Inches
- mm = Millimeters
- SHCS = Socket Head Cap Screw



EASY-TOUCH™ BAR SANDER

A flat, durable, easy to handle sanding tool is a necessity for building a well finished model. Great Planes makes a complete range of Easy-Touch Bar Sanders and replaceable Easy-Touch Adhesive-backed Sandpaper. While building the P-38 Profile, two 5-1/2" [140mm] Bar Sanders and two 11" [280mm] Bar Sanders equipped with 80-grit and 150-grit Adhesive-backed Sandpaper were used.

Here's the complete list of Easy-Touch Bar Sanders and Adhesive Backed Sandpaper:

- 5-1/2" Bar Sander (GPMR6169)
- 11" Bar Sander (GPMR6170)
- 22" Bar Sander (GPMR6172)
- 33" Bar Sander (GPMR6174)
- 44" Bar Sander (GPMR6176)
- 11" Contour Multi-Sander (GPMR6190)

- 12' roll Adhesive-backed 80-grit sandpaper (GPMR6180)
- 150-grit (GPMR6183)
- 180-grit (GPMR6184)
- 220-grit (GPMR6185)
- Assortment pack of 5-1/2" strips (GPMR6189)

We also use Top Flite 320-grit (TOPR8030, 4 sheets) and 400-grit (TOPR8032, 4 sheets) wet-or-dry sandpaper for finish sanding.

TYPES OF WOOD

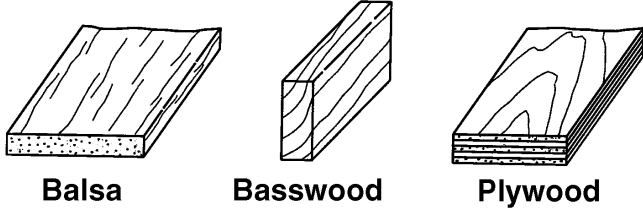

GET READY TO BUILD

1. Unroll the plan sheet. Re-roll it inside out to make it lie flat.
2. Remove all parts from the box. As you do, figure out the name of each part by comparing it with the plans and the parts list included with this kit. Using a felt-tip or ballpoint pen, lightly write the part **name** or **size** on each piece to avoid confusion later. Use the die-cut drawings shown on page 7 to identify the die-cut parts and mark them before removing them from the sheet. **Save all scraps.** If any of the die-cut parts are difficult to punch out, do not force them! Instead, cut around the parts with a hobby knife. After punching out the die-cut parts, use your Bar Sander or sanding block to **lightly** sand the edges to remove any die-cutting irregularities or slivers.

DIE-CUT DRAWINGS

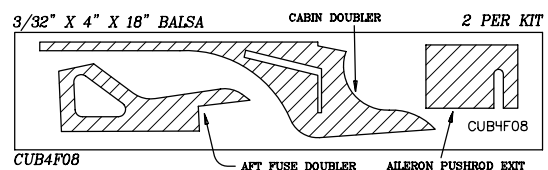
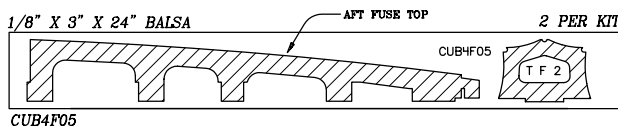
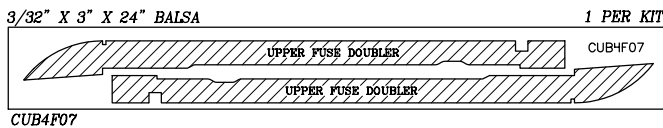
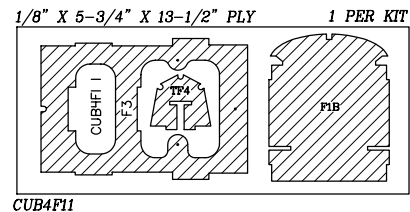
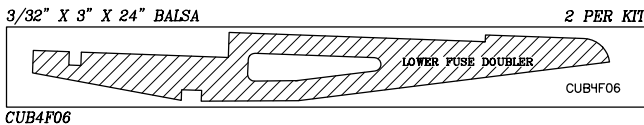
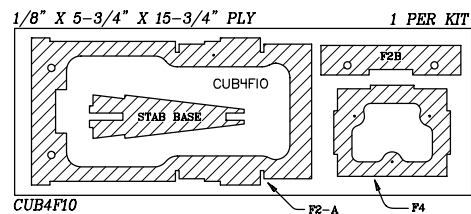
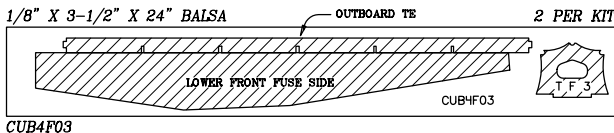
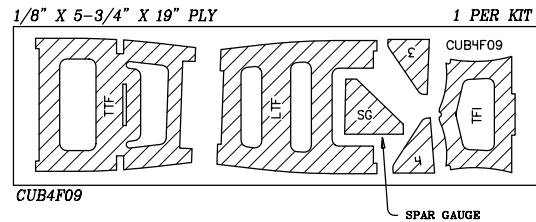
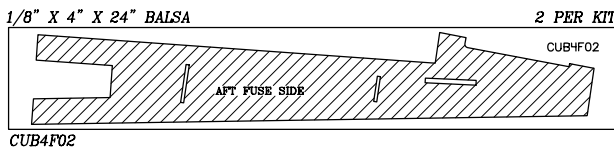
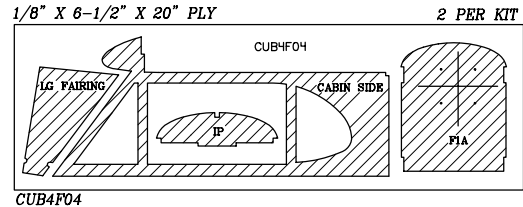
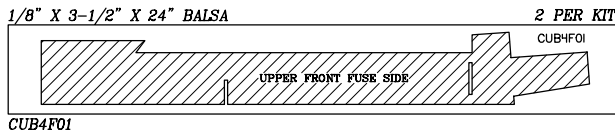

DIE-CUT DRAWINGS

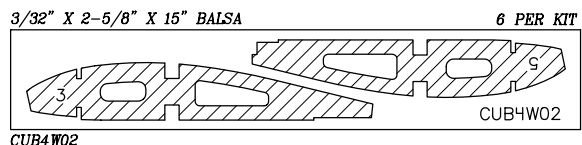
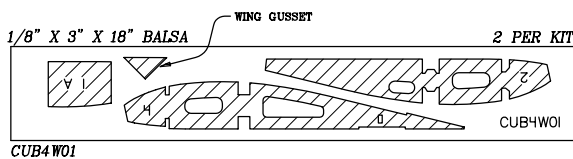
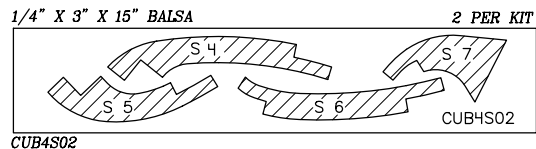
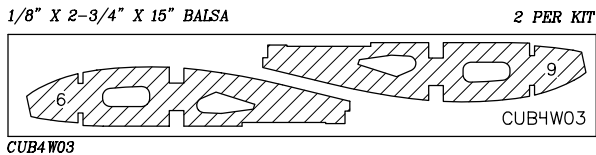
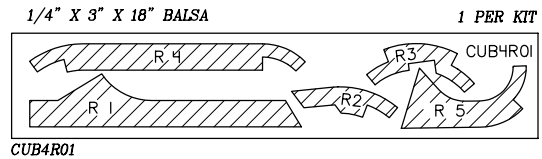
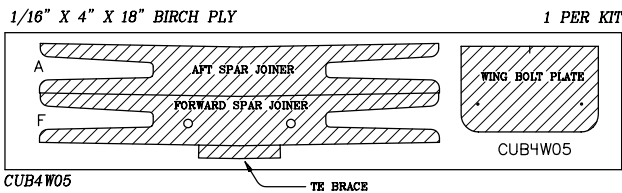
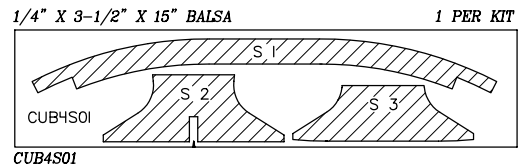
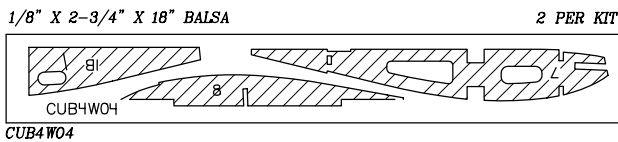
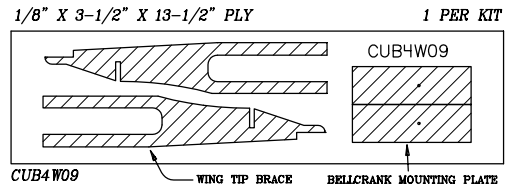
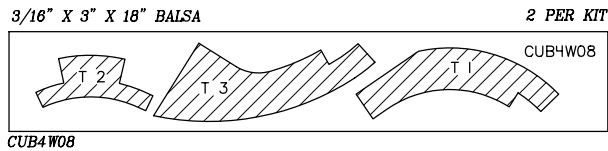
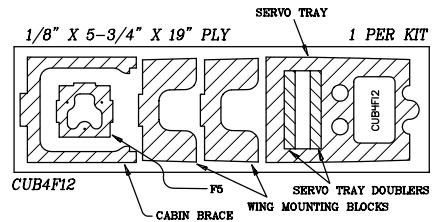
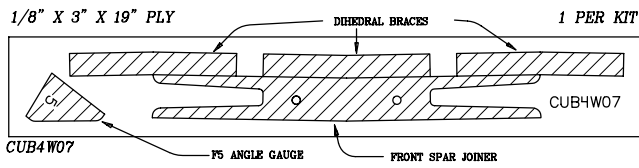

1/64" = .4 mm
 1/32" = .8 mm
 1/16" = 1.6 mm
 3/32" = 2.4 mm
 1/8" = 3.2 mm
 5/32" = 4.0 mm
 3/16" = 4.8 mm
 1/4" = 6.4 mm

METRIC CONVERSIONS

3/8" = 9.5 mm
 1/2" = 12.7 mm
 5/8" = 15.9 mm
 3/4" = 19.0 mm
 1" = 25.4 mm
 2" = 50.8 mm

3" = 76.2 mm
 6" = 152.4 mm
 12" = 304.8 mm
 18" = 457.2 mm
 21" = 533.4 mm
 24" = 609.6 mm
 30" = 762.0 mm
 36" = 914.4 mm

TAIL FEATHERS

Build the Rudder

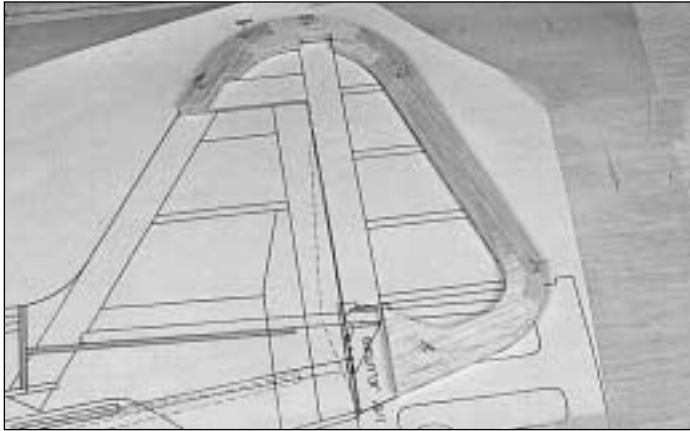

❑ 1. Tape **waxed paper** over the **Rudder** drawing on the fuse plans. Remove the die-cut 1/4" balsa parts **R2,R3,R4** and **R5** from CUB4RO1. Place all the parts over the plan in their locations and check the joints for good fits. Use a T-bar or other flat sanding block to make any necessary adjustments. Pin the parts to the building board after proper alignment and fitting has been done.

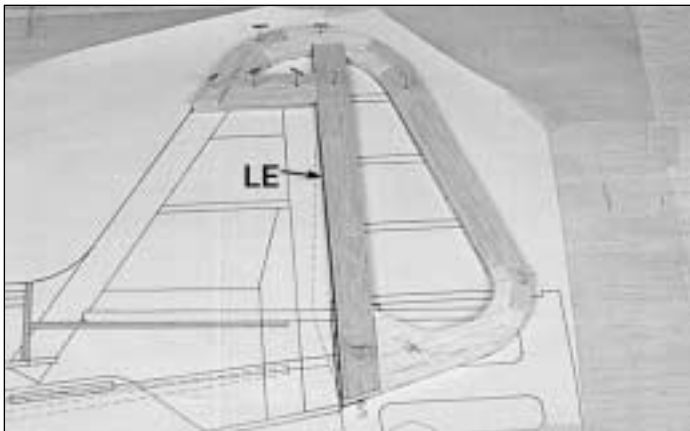

❑ 2. Cut the rudder **LE** from the 1/4" x 3/4" x 24" balsa strip (CUB4S03). **NOTE:** Look over the three CUB4S03's and mark the straightest one to be used later for the stab TE. Fit the LE into the notch in **R3** and against the edge of **R5**. Cut the **horizontal** frame section from the 1/4" x 3/4" balsa strip and fit it in position. Pin the LE and horizontal frame section in place and securely glue all joints with thin CA. Wipe any excess glue off with a paper towel before it cures (this will make sanding much easier). **NOTE:** Leave all the parts pinned to the building board.

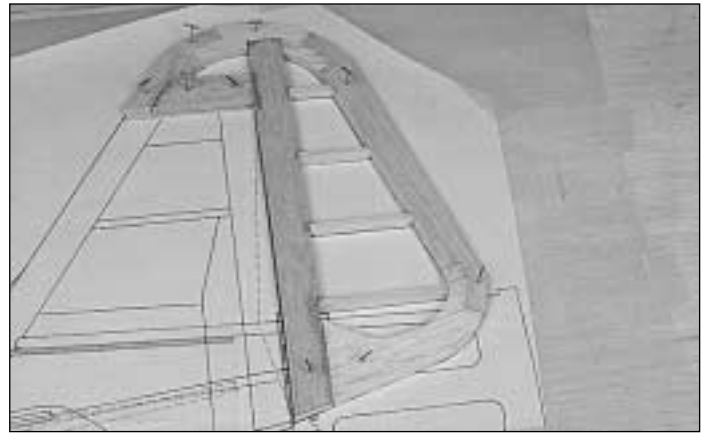

❑ 3. Cut the four **Ribs** from the 3/16" x 1/4" x 24" balsa stick (CUB4S04). Fit the ribs into the rudder frame and securely glue them in place with thin CA.

❑ 4. Remove the **Rudder** from the building board and inspect all the glue joints on the bottom side. Add thin CA to all the tight fitting joints and thick CA to any open joints. **NOTE:** The process of re-gluing the joints on the bottom side is necessary on the thick balsa parts. This will ensure the complete wicking of the CA throughout the entire joint.



❑ 5. Place the Rudder on a flat work surface and lightly sand both sides flat and smooth using a T-Bar or good flat sanding block with medium grit sandpaper.

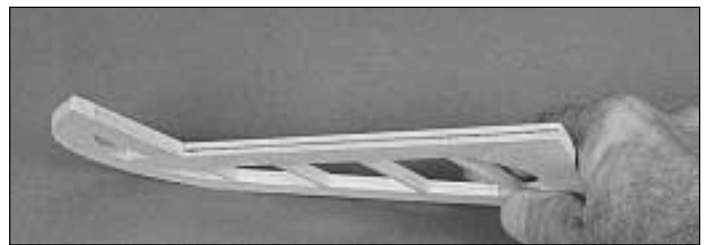

❑ 6. Carefully draw a **centerline** on the LE and TE of the rudder. This will help you to maintain symmetry when sanding these edges.

❑ 7. Using a flat sanding block, sand the **top** and the **TE** of the rudder to a **rounded** shape. Sand the LE to a **"V-shape"** as shown on the plans.

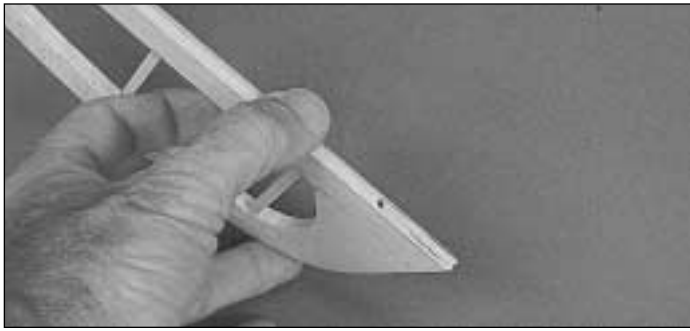

- 8. Check the plans and mark the location of the **tailgear** on the rudder. Drill a **7/64"** hole in the rudder **3/4"** deep (the hole is drilled slightly oversize to allow room to create a hard epoxy "sleeve" around the wire). Then **groove** the rudder LE to accept the tailgear wire.

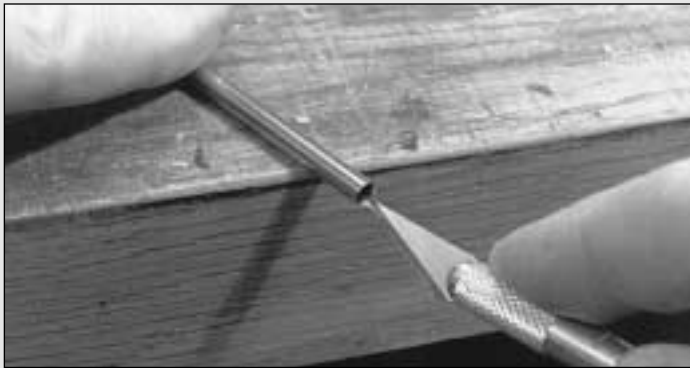

Using a hobby knife, sharpen the inside of one end of a 1/8" diameter brass tube, and use it to cut the groove in the LE of the rudder as shown below.

Build the Fin

- 1. Tape **waxed paper** over the **Fin** drawing on the fuse plans. Remove the 1/4" die-cut balsa **R1** from (CUB4RO1). Place R1 on the plan and pin in place.

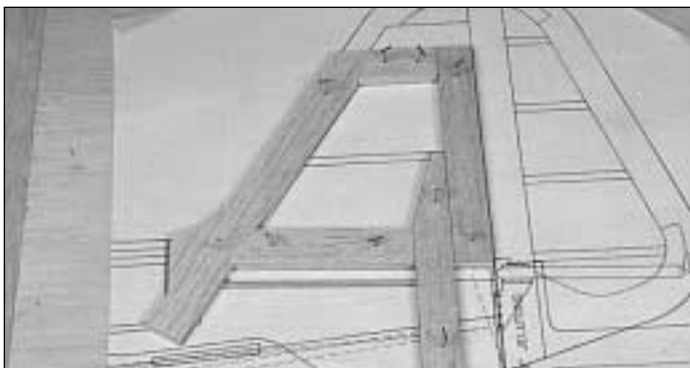

- 2. Cut the remaining **fin frame** parts from the **1/4" x 3/4" x 24"** balsa strip (CUB4SO3). Pin the parts in place and

make sure all the joints are good and tight. Securely glue all the joints with thin CA. **Note:** The bottom end of the trailing edge stops at the top edge of the horizontal stabilizer.

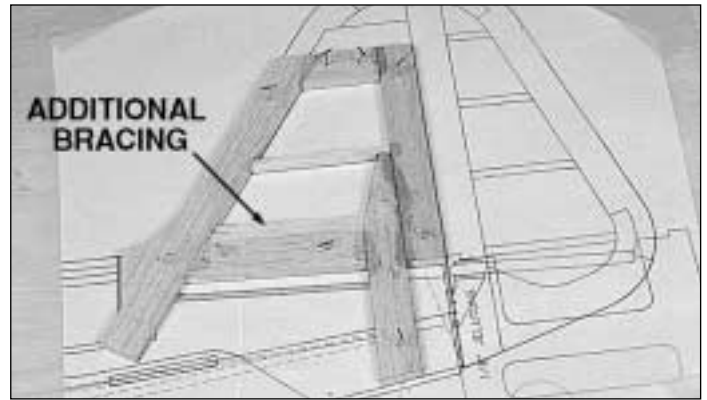

- 3. Cut three **Ribs** from the **3/16" x 1/4" x 24"** balsa stick (CUB4SO4). Fit one rib in place and glue it with thin CA. Add two more ribs for additional bracing above the lower frame.

- 4. Remove the **Fin** from the building board and inspect all the glue joints. Glue all the tight fitting joints on the bottom side of the fin with thin CA and add thick CA to any open joints.

- 5. Place the **Fin** on a flat work surface and lightly sand both sides flat and smooth.

- 6. Draw a **centerline** on the **LE** and **TE** of the fin. The lines will assist you in the final shaping of the LE and hinge positioning on the TE.

- 7. Sand the **LE only** to a rounded shape to match the cross-section shown on the plans. **NOTE:** The trailing edge, bottom edge and top edge must **not** be rounded or V-shaped. Instead, just sand these edges flat and square.

Build the Stabilizer

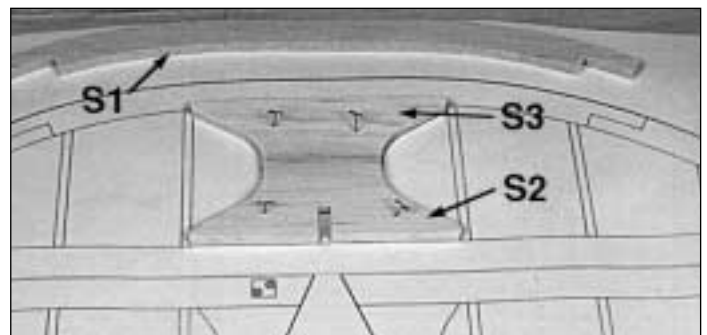

- 1. Tape **waxed paper** over the **Stabilizer** drawing on the fuse plan. Remove the die-cut 1/4" balsa parts **S1**, **S2** and **S3** from (CUB4SO1) and the two **S4**'s from (CUB4SO2). Place **S2** and **S3** over the plan to check their fit together. Sand the parts as necessary to ensure a good fitting joint. Pin S2 and S3 in place over the plans and glue them together.

- ❑ 2. Position the **S1** and the two **S4**'s over their locations on the plans. Check the fits of the joints and sand them if necessary. Pin them in place.



- ❑ 3. Cut the **Stabilizer TE** from the **1/4" X 3/4" X 24"** balsa strip (CUB4S03). Fit the **TE** between the **S4**'s and glue it in place with thin CA.

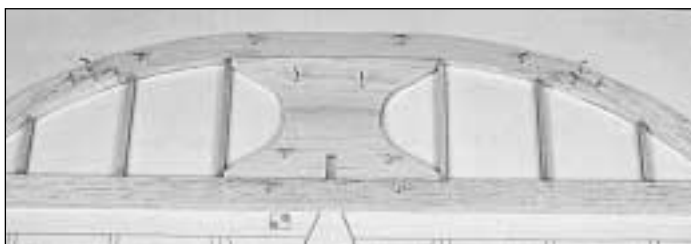

- ❑ 4. Cut the **Ribs** from the **3/16" x 1/4" x 24"** balsa stick (CUB4S04). Fit the Ribs in the stabilizer frame and glue them in place with thin CA.

- ❑ 5. Remove the stabilizer from the building board and inspect all the glue joints. Glue all the tight fitting joints on the bottom side of the stab with thin CA and add thick CA to any open joints.

- ❑ 6. Place the **stabilizer** on a flat work surface and lightly sand both sides flat and smooth.

- ❑ 7. Draw a **centerline** on the **TE** of the stabilizer. The centerline will be used later to assist in positioning the hinges.

- ❑ 8. Sand the **LE only** of the stabilizer to a nice rounded shape as shown on the plans.

Build the Elevators

- ❑ 1. Tape **waxed paper** over the **Elevator** drawing on the fuse plan. Remove **S5, S6, and S7** from the 1/4" die-cut balsa sheet CUB4S02. Position the parts over the plans and check the fit of the joints. Sand the parts as necessary to ensure good fitting joints. Pin the parts in place over the plans and glue them together with thin CA.

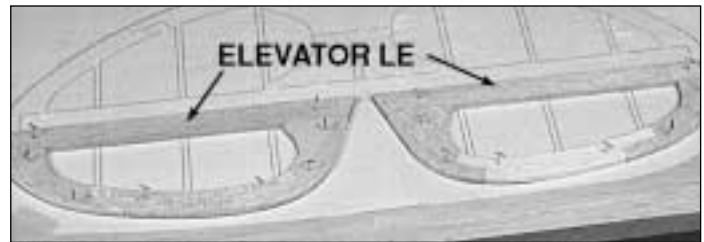

- ❑ 2. Cut the **Elevator LE** from the **1/4" x 3/4" x 24"** balsa strip (CUB4S03) and pin it in place. Glue all the joints with thin CA.

- ❑ 3. Cut the elevator **Ribs** from the **3/16" x 1/4" x 24"** balsa stick (CUB4S04). Fit the ribs in the elevator frame and glue with thin CA.

- ❑ 4. Remove the elevators from the building board and inspect all the glue joints. Glue all the tight fitting joints with thin CA and add thick CA to any open joints.

- ❑ 5. Place the **elevators** on a flat work surface and lightly sand both sides flat and smooth using a T-bar or other good flat sanding block.

- ❑ 6. Carefully draw a **centerline** all around the edges of the elevators.

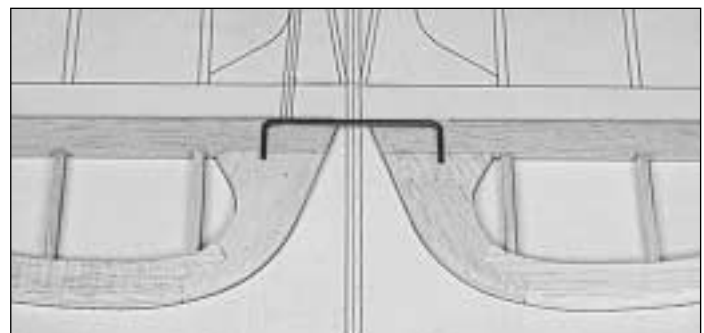

- ❑ 7. Temporarily pin the elevators to the plan. Lay the 1/8" wire **elevator joiner** (WBNT194) in place on the elevators and mark its outline using a soft lead pencil. **NOTE:** Mark the elevator joiner wire outline very lightly so that it will not be seen through the covering material.

- ❑ 8. Accurately drill a **1/16"** diameter pilot hole approximately **3/4"** deep at each location. Then drill the final hole with a **9/64"** drill bit to a depth of **7/8"**. (The hole is drilled slightly oversize to allow for positioning, and to allow room to create a hard epoxy "sleeve" around the wire. **NOTE:** The joiner wire must be centered on the centerline of the stabilizer. The holes must be drilled perpendicular to the LE and parallel to the top and bottom surfaces of the elevators.

- ❑ 9. Use the sharpened **1/8"** diameter brass tube to cut grooves in the leading edge of the elevators to accept the joiner wire.

- ❑ 10. Sand the **LE** to a "V"-shape and the entire **TE** to a rounded shape. Check the plans for the proper cross-sections.

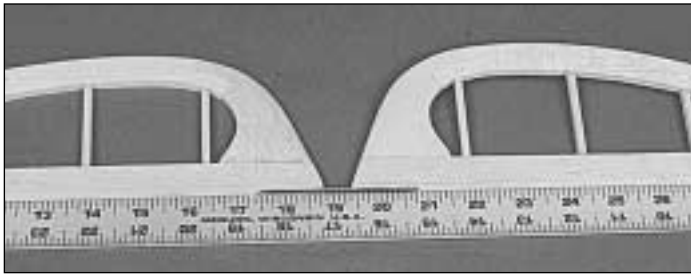

❑ 11. Test fit the joiner wire into both elevators. Position the elevators against a straight edge to check for straightness of the LE with the joiner wire installed. Adjust the holes if needed to achieve a straight LE.

❑ 12. Roughen the joiner wire with coarse sandpaper, then clean the wire thoroughly with alcohol to remove any oily residue.

❑ 13. Glue the joiner in place using 30-minute epoxy. When gluing, lay the elevators on a flat surface with the leading edges along a straightedge to ensure perfect alignment.

Cut the Hinge Slots

NOTE: A strip of Ultra-Grip hinges are supplied in this kit. If you choose to use the “pinned”-type hinges, you should cut the hinge slots at this time. However, if you choose to use the Ultra-Grip hinges that are furnished in this kit, you may wait until after covering before cutting the hinge slots. The strip of Ultra-Grip hinges must be cut as shown in the sketch below.

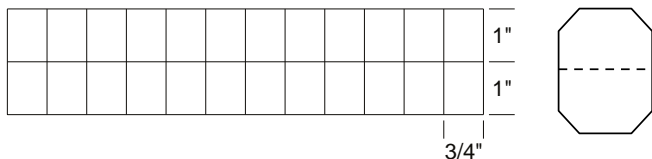

❑ 1. Lay the rudder and elevators on the plan and mark the hinge locations. Place the rudder against the fin TE and transfer the marks over to the fin. Place the elevators against the stab TE and transfer the marks over to the stab.

CAUTION!!!: You must use extreme care when cutting hinge slots with a hobby knife, to avoid cutting yourself! If the balsa part breaks while you are pushing on the knife, the blade could go into your hand before you know it! A good precaution is to wear leather gloves while performing the following steps, and always cut away from yourself.

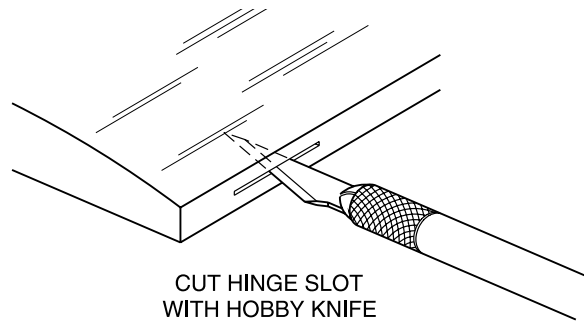

CUT HINGE SLOT WITH HOBBY KNIFE AND #11 BLADE

❑ 2. Cut the hinge slots **on the centerlines which you previously drew**, using a hobby knife following the recommended hinge slotting technique listed below. **NOTE:** For pinned hinges use a slotting fork and slotting hook.

❑ A. Begin by carefully cutting a **very shallow slit** at the hinge location. This first cut is to establish your cut in the right place, so concentrate on staying on the centerline and **don't cut too deep!**

❑ B. Make three or four more cuts in the same line, **going slightly deeper each time**. As you make these additional cuts, work on going straight into the wood. Continue this process while **“wiggling”** the knife handle back and forth until the blade has reached the proper depth for the hinge.

❑ C. Trial fit the hinge into the slot. If the hinge is difficult to push in, re-insert the knife and move it back and forth in the slot a few times to enlarge the slot.

❑ 3. Insert the hinges into the slots and trial fit the rudder and elevators in place on the fin and stab. **Do not glue the hinges until after you have covered the model.**

WING ASSEMBLY

Build the Wing Panels

NOTE: It will be helpful to build the wing on a piece of “Celotex” or other semi-soft (and flat) surface, into which you may easily stick pins to firmly hold down the wing parts while building, to avoid warps.

NOTE: You may build one of two different wings from this kit. The standard scale wing or the clipped wing version. You will need to decide now which version you would like to build. Regardless of your decision, the wings LE's and TE's will require trimming. Carefully study the LE and TE trim diagram on the wing plan. Lay the LE and TE directly over the plan and trim accordingly. No change to the plans is necessary for the standard scale wing. If you decide to build the clipped wing version, cut the plans on the dashed lines. Slide the outer halves of each wing panel over the inner halves and match the registration marks between the

first two #3 ribs. Keep the plans aligned and tape the inner and outer halves together. The plans are now ready to use for the clipped wing version.

1. Tape the plan to your flat work surface. Align a straightedge on the wing centerline and draw a continuous line extending out past the leading and trailing edges. Do this for both the right and left wing panel plans. This centerline will be used at various times during the wing construction. Cover the wing drawing with waxed paper (so you won't glue the wing to the plan!).

**TWO WARPED SPARS INSTALLED
THIS WAY WILL RESULT IN A
STRAIGHT WING**



**TWO WARPED SPARS INSTALLED
THIS WAY WILL RESULT IN A
WARPED WING**



2. Before using the 3/8" x 3/8" x 33-1/2" basswood Spars (CUB4W06), examine them carefully for possible imperfections. Look for knots, soft spots, diagonal grain and any other imperfections. If possible, position each spar so the imperfections are on the outer half of the wing panel (toward the tip), where they will be least affected by high stress. If the spars are warped slightly, try to "balance them out" by installing the warped spars in opposite directions.

3. Carefully punch out all the die-cut 3/32" balsa #3 and #5 ribs (CUB4W02) and the die-cut 1/8" balsa #2, #4, #6, #7 and #8 ribs (CUB4W01, CUB4W03 and CUB4W04). Sand the edges slightly to remove any die-cutting irregularities.

NOTE: Follow steps 4 through 30 to build the LEFT wing panel, then repeat these steps to build the RIGHT wing panel.

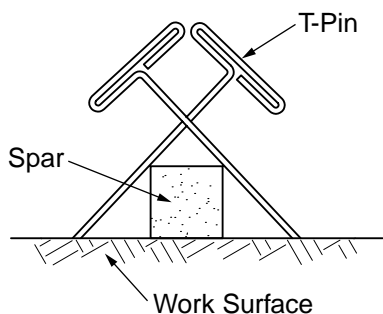

4. Place one of the 3/8" x 3/8" x 33-1/2" Basswood Spars (CUB4W09) on the wing plan and pin the spar down with crossed T-pins as shown in the following sketch. **NOTE:**

Align the end of the spar with the outboard edge of rib #7. The spars are cut slightly too long, and the excess will be cut off later at the center of the wing.

5. Place the 1/16" x 1-3/8" x 36" balsa TE Sheeting (CUB4W13) on the plans but do not pin it yet. Align one end of the sheeting with the wing centerline.

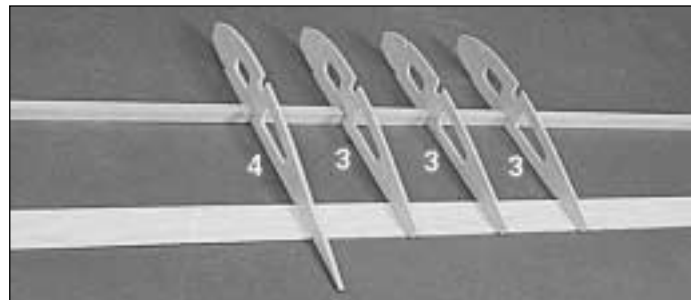

6. Place three of the #3 ribs and one of the #4 ribs on the spar in their locations shown on the plans, but do not glue. Slide the TE sheeting to the forward edge of the notches in the bottom of the ribs. The TE sheeting is used only as a shim for the rib ends at this point.

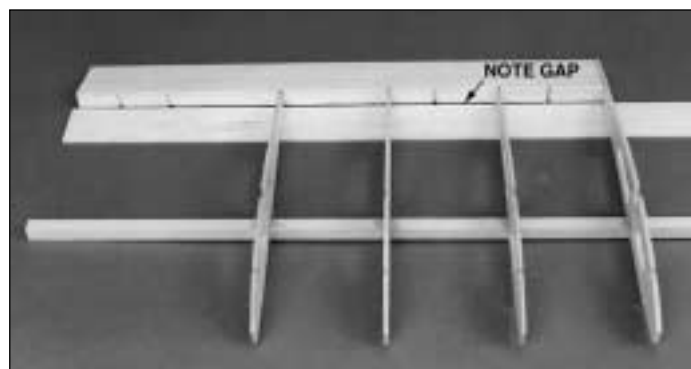

7. Carefully check the notches on the TE (CUB4W11). The 1/8" wide notches are to be positioned over the #1 and #2 rib locations on the plans. Align the outboard end of the TE with the aft end of the #4 rib. Insert the aft ends of the #3 ribs into the notches in the TE. Make sure the ribs are down against the sheeting and building board and glue the ribs to the spar and the TE with thin CA. The TE sheeting should hold the ribs 1/16" above the work surface.



8. Slide the bottom sheeting back against the TE and align it with the inboard end of the TE. Glue the bottom sheeting to the TE and the ribs.

☐ ☐ 9. Carefully inspect the notches in the die-cut 1/8" balsa **Outboard TE** (CUB4F03). The 1/8" wide notches are to be aligned with the #6 rib locations. Insert the tab on the die-cut outboard TE into the slot at the aft end of the #4 rib, with the **notches facing up**.

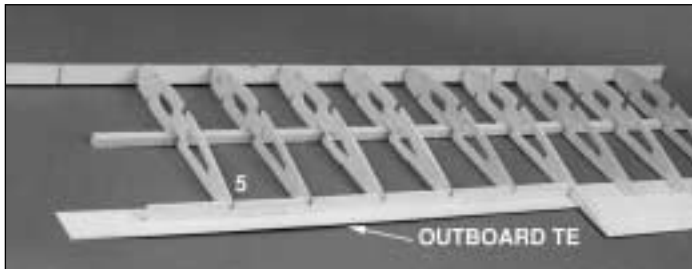

☐ ☐ 10. Place the outboard #5 rib on the spar at the proper location and insert the aft end of the rib into the proper notch in the outboard TE. **Do not glue yet!**

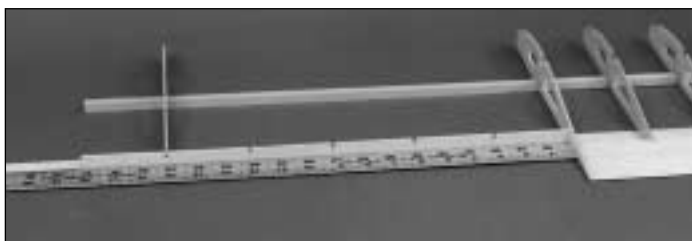

☐ ☐ 11. Use a straightedge to keep the outboard TE straight as shown in the photo and glue it to the bottom TE sheeting with thin CA. Be careful not to glue the straightedge to the sheeting.

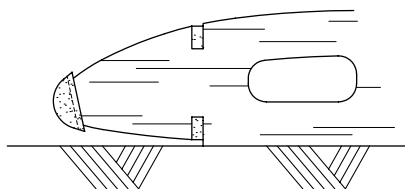

☐ ☐ 12. Position the notched **LE** so the 1/8" wide notches are near the #2, #4, #6, #6 and #7 positions. Place it on the ribs so the ribs are centered vertically on the LE to allow for the LE sheeting which will be installed later. Glue it in place with thin CA.

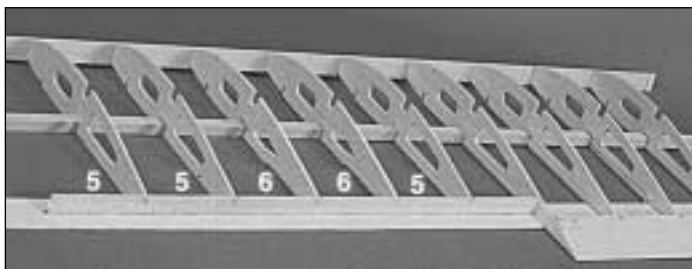

☐ ☐ 13. Install the remaining #5 and #6 ribs. Glue them to the LE, the spar, the outboard TE and the bottom TE sheeting. Make sure they are centered on the LE and down against the bottom TE sheeting.

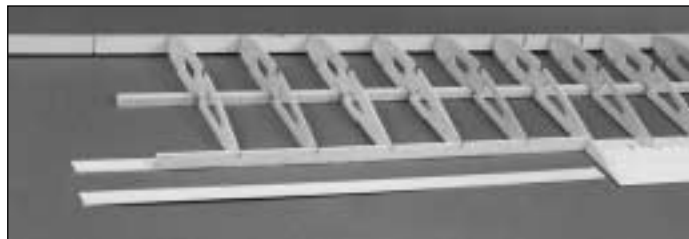

☐ ☐ 14. Trim the bottom sheeting in the aileron area, along the #4 rib and the **outboard TE** to the end of the sheet. Maintain a straight cut past the #7 rib location. You may want to slide a thin piece of hard plastic under the bottom sheeting to avoid cutting into the plans when making this cut.

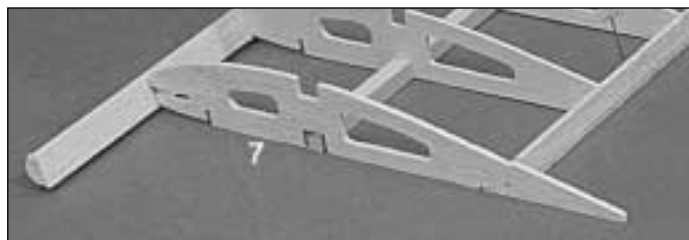

☐ ☐ 15. Position the #7 rib in place over the plans and onto the tab at the end of the outboard TE. Glue the rib to the LE, the **front** and **top** edges of the spar, the outboard TE and the bottom TE sheeting. Trim the bottom sheeting even with the outboard edge of the #7 rib.

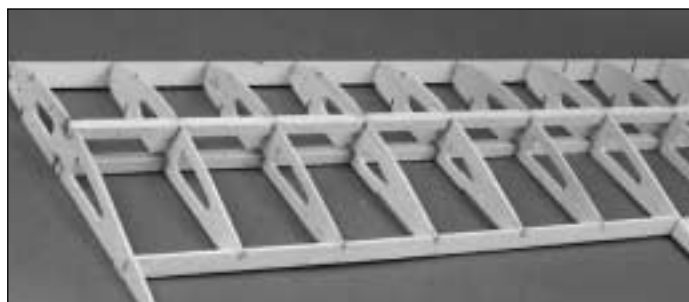

☐ ☐ 16. Insert the 3/8" x 3/8" basswood **Top Spar** (CUB4W09) into the notches in the ribs. Align the end of the spar to the outboard edge of the #7 rib. Glue the spar to all the ribs, with the spar against the front of the notch in the #7 rib. Make sure the top surface of the spar is level with the top edges of the ribs. **NOTE:** Check to make sure the spar is positioned properly to ensure a straight wing (see step 2).

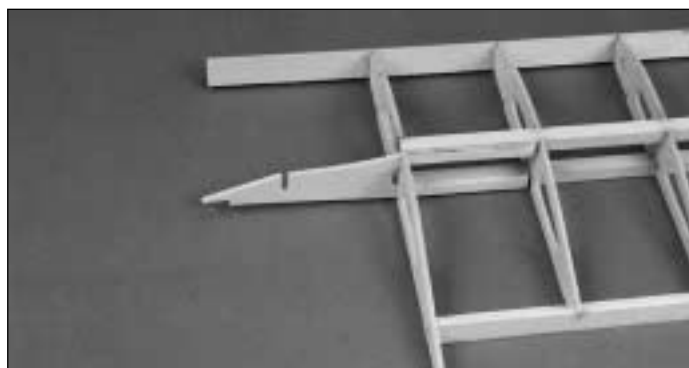

☐ ☐ 17. Install a die-cut 1/8" plywood **Wing Tip Brace** (CUB4W09) at the rear of the spars through the notches in

the #7 rib. Align the top notch in the wing tip brace with the #8 rib on the plans and glue the brace in place. Make sure the "legs" of the brace are parallel with the spars.



□ □ 18. If you are currently building the left wing panel, assemble the wing tips over the right wing panel plan. Place the die-cut 3/16" balsa **Wing Tip** parts **T1**, **T2** and **T3** (CUB4W08) over the plans and check all joints for proper fits. Sand the parts if necessary for good fitting joints. Pin them in place and glue the pieces together with thin CA.

□ □ 19. Remove the Wing Tip from the building board and inspect all the glue joints on the bottom side. Add thin CA to all the tight fitting joints and add thick CA to all the open joints.

□ □ 20. Place the Wing Tip on a flat work surface and lightly sand both sides flat and smooth.

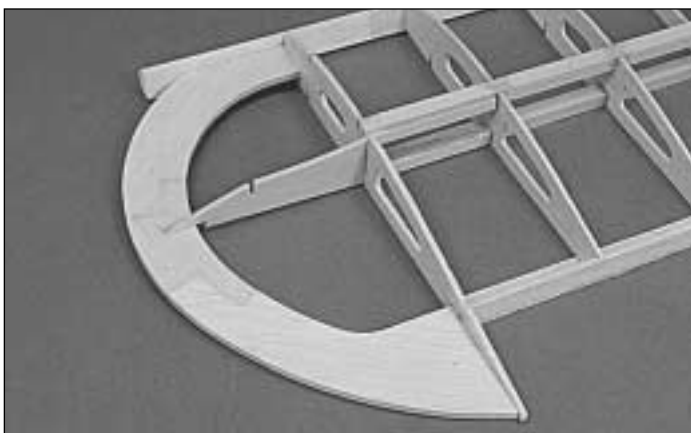

□ □ 21. Sand the front edge of the Wing Tip to match the angle of the LE. Test fit the wing tip into the slot at the front of rib #7 and align the aft end of the wing tip with the aft end of rib #7. Glue the wing tip to the LE, the wing tip brace and rib #7.

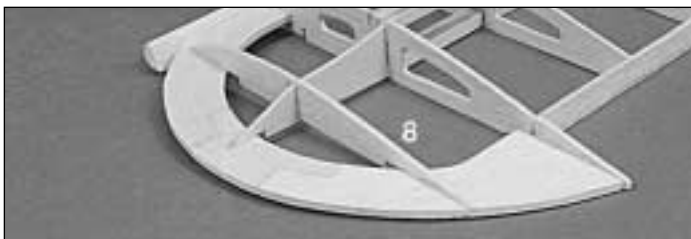

□ □ 22. Insert rib #8 into the notch in the wing tip brace so the ends of the rib rest on the wing tip. Align the rib over the plans and glue it in place. Sand the top and bottom outside edges of the wing tip to remove the sharp corner where the leading edge sheeting will be attached later.

□ □ 23. Install rib #2 by sliding it in between the spars and twisting it into place. Center it on the LE and glue it with thin CA. **Do not glue it to the spars yet!** **Note:** Maintain a 1/16" gap between the bottom edge of the rib and the work surface to allow for the center sheeting which will be installed later. Use a scrap piece of 1/16" balsa to hold the rib up off the work surface.



□ □ 24. Securely glue **eight** (six for the clipped wing Cub) of the pre-cut 1/16" x 2-7/8" x 1-7/16" balsa vertical grain **shear webs** (CUB4W20) to the rear surface of the spars, starting between the two #5 ribs near the wing tip end of the wing and working towards the center of the wing. Medium or thick CA works best for this. Securely glue a shear web to the **front** surfaces of the spars in the two rib bays between the #3 ribs as shown in the next photo.

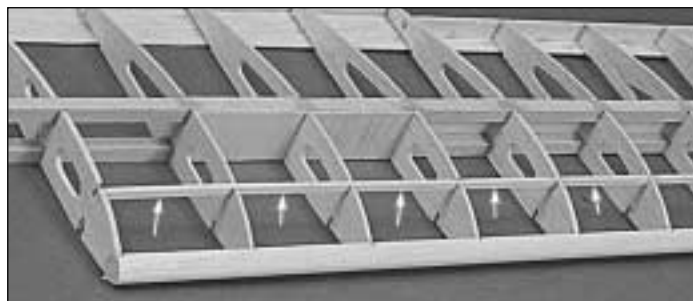

□ □ 25. Install the 1/8" x 1/4" x 33-1/2" balsa **Top Forward Spar** (CUB4W12) in the forward rib notches, starting with the #7 rib. Press the spar down firmly into the notches and glue it in place with thin CA. Trim the forward spar and LE even with the inboard side of the #2 rib and even with the outboard side of the #7 rib.



□ □ 26. Position four 1/4" x 3/8" x 1-1/2" balsa **Hinge Blocks** (CUB4W21) against the Outboard TE at the locations shown on the plans and glue them in place with CA. Notice that they are centered vertically on the outboard TE and not placed down against the bottom TE sheeting.

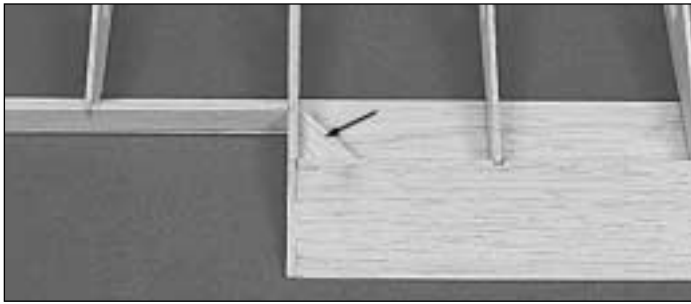

□ □ 27. Place the die-cut 1/8" balsa triangular **Gusset** (CUB4W01) in the corner formed by the #4 rib and the tapered TE. Securely glue it in place.



(Photo taken at a later stage of completion.)

□ □ 28. Glue the 1/2" x 3/4" x 1" basswood **Wing Strut Mounting Blocks** (CUB4W22) to the outboard side of the second #6 rib. They should be flush with the bottom of the rib and positioned as shown on the plans. Cut four 1" long pieces of 3/8" balsa **Triangle** (CUB4W24) and glue one piece on top of each mounting block. There are **six** of these blocks included in this kit, two of which are (CUB4F20). The strut mounting blocks must be down flat on the building surface when gluing it to the rib. The front block will be flush with the bottom of the rib, but the aft block will be 3/32" below the bottom edge of the rib because the balsa sheeting has not yet been installed in the bellcrank bay.



□ □ 29. Use the die-cut 1/8" ply **Spar Gauge** (CUB4F09) to mark where to cut the spars and TE off. Hold the gauge flat against the work surface and line it up with the centerline on the plans. Mark along the almost vertical edge and then cut the spars off along these lines. This will make the top spar slightly shorter than the bottom spar to allow for the dihedral angle. In addition to the spars, mark and cut off the bottom TE sheet and the tapered TE at the wing centerline.

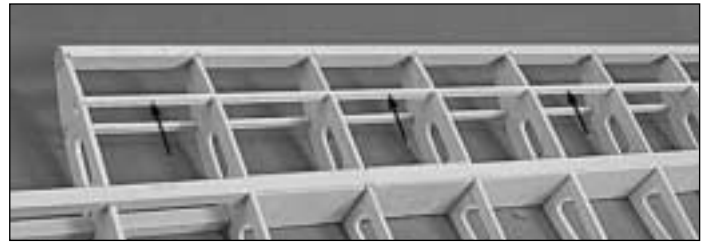

□ □ 30. Remove the wing panel from the work surface and install the 1/8" x 1/4" x 33-1/2" **Bottom Forward Spar** (CUB4W12) following the same procedure used in step 25.

□ 31. Go back to step 4 and build the other wing panel.

Joining the Wing Panels

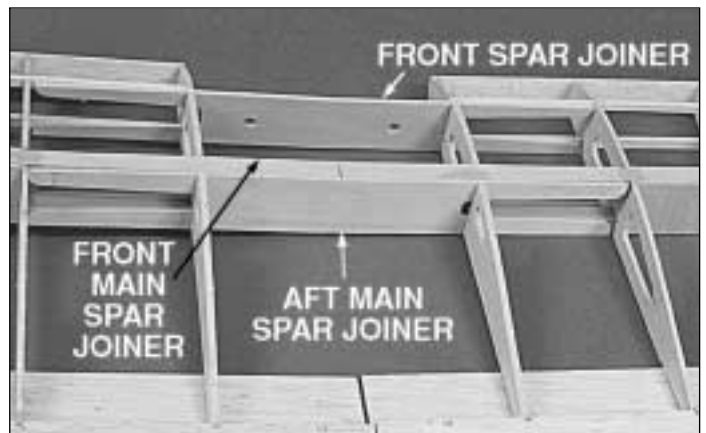

□ 1. Using the die-cut 1/8" ply **Front Spar Joiner** (CUB4W07) and the die-cut 1/16" ply **Forward** and **Aft Main Spar Joiners** (CUB4W05), test fit (DO NOT GLUE) the two wing panels together. With the center of the wings resting on the work surface, block up both wing tips 5/8" (1/2" for the clipped wing) as measured from the work surface to the bottom of rib #7. Check the fit of the spars and the TE to make sure they meet up nicely without producing any sweep in the wing. Take the panels apart and sand the spars or TE's if necessary to achieve the correct alignment. **NOTE:** The holes in the die-cut 1/8" plywood Front Spar Joiner and the holes in the die-cut 1/16" ply Forward Main Spar Joiner must be **centered** on the centerline of the wing. Make sure you trim the ends of the spar joiners as needed to allow the wing panels to come together and the spars to touch. It is typical to have to trim 1/16" from the ends of the joiners. It is also likely likely that you will have to deepen the notches in the #2 ribs slightly to allow the joiners to slide fully into place.



□ 2. Glue the three die-cut 1/8" plywood **Dihedral Braces** (CUB4W07) together as shown in the photo.



❑ 3. Trial fit the dihedral brace between the main spars of the wing. Sand the edges of the dihedral brace if necessary to get it to fit without forcing the spars apart.

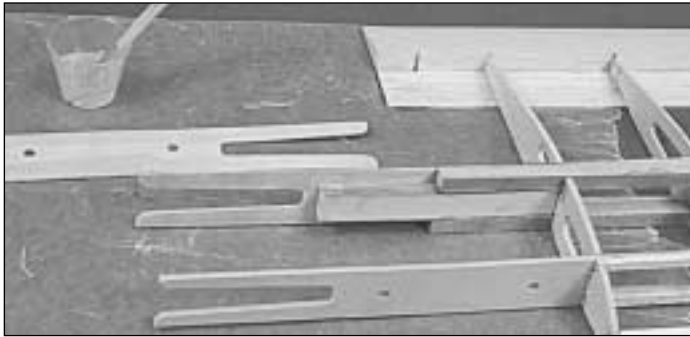

❑ 4. **IMPORTANT: Use a good quality non-brittle epoxy for this task, such as Great Planes Pro 30-minute Epoxy.** Place waxed paper on the work surface and mix up a batch of epoxy. Apply it to the top and bottom of the dihedral brace, the spar joiners, the spars, spar ends and the ends of both TE's. Apply plenty of epoxy, to fully fill all voids at the center of the wing. Slide the spar joiners and the dihedral brace into one wing panel first. Slide the other wing panel into place and wipe off any excess epoxy. **Immediately proceed to the next step.**



❑ 5. Block up each wing panel $\frac{5}{8}$ " ($\frac{1}{2}$ " for the clipped wing) as measured from the work surface to the bottom of rib #7. Carefully align the spars and the TE of both wing panels. Clamp the spar joiners to the spars and wipe off any excess epoxy with a paper towel. **Allow the epoxy to fully harden before disturbing the wing and removing the clamps.** Wipe out any excess epoxy in the holes in the forward main spar joiner.

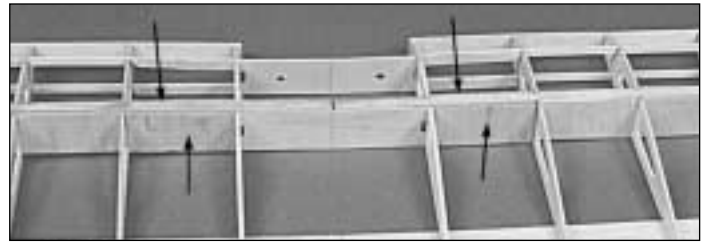

❑ 6. Securely glue the remaining four $\frac{1}{16}$ " balsa vertical grain shear webs to the front and back sides of the main spar joiners between the #2 and #3 ribs.

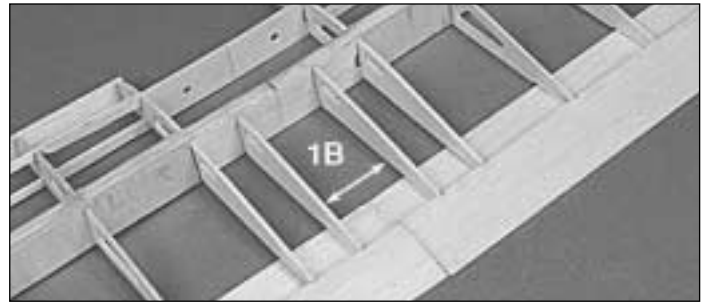

❑ 7. Install the two #1B ribs as shown in the photo. The top surface of each rib should be flush with the top surface of the spars.

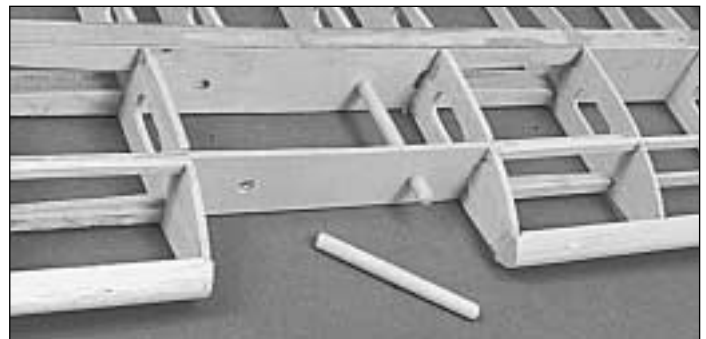

❑ 8. Round off one end of each $\frac{1}{4}$ " x 3" hardwood **Wing Dowel** (DOWEL017). Slightly chamfer the other end of each dowel. Slide the chamfered end of both dowels into the wing and securely glue them to both spar joiners with either thick CA or epoxy.



❑ 9. Install the two #1A ribs as shown in the photo. The top surface of each rib should be flush with the top surface of the spars.

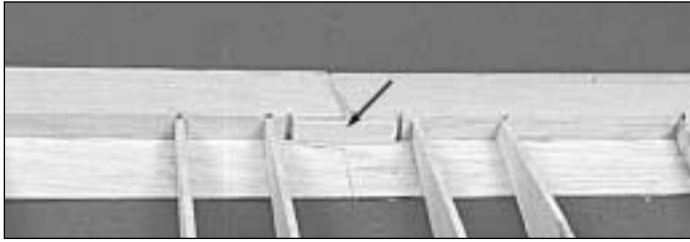

❑ 10. Glue the die-cut 1/16" ply **TE Joiner** (CUB4W05) in place between the **#1B** ribs as shown in the photo.



(Wing is upside down in photo.)

❑ 13. Hold your aileron servo in position against the servo rails and mark where to drill the mounting holes. Drill 1/16" holes at each mark and mount your servo using the screws provided with the servo. **NOTE:** The screws are installed from the bottom side of the servo lugs.

Install Aileron Linkage

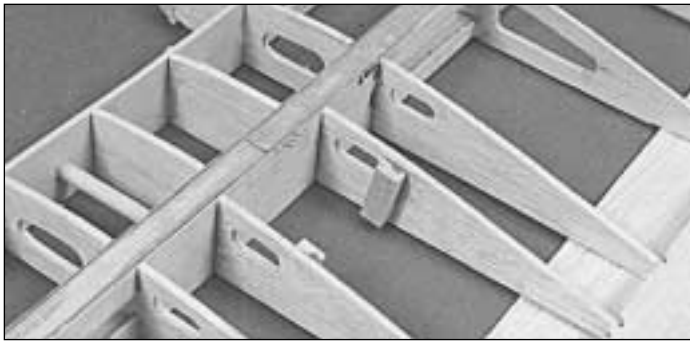

❑ 11. Glue the 5/16" x 3/8" x 1" basswood **Aileron Servo Rails** (CUB4W22) to the inboard sides of both **#1B** ribs as shown on the plans. Line up the front edge of each servo rail with the embossed angled line near the back of the pushrod hole in the ribs. The embossed line will be on the wrong side of one rib, but you can still eye it while positioning the servo rail. **NOTE:** If you are using a servo smaller than a Futaba S148, you may need to glue a spacer between the servo rails and the ribs to correctly space the rails to fit your servo.



❑ 12. Cut all the arms except one off of a large servo horn and mount the **Threaded Ball** (SCRW058) in the outer hole of the arm as shown in the photo. Install the arm on the servo so it is perpendicular to the servo (neutral position).

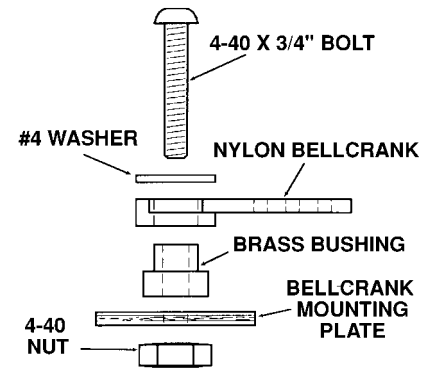

❑ 14. Drill a 1/8" hole at the punch mark on each die-cut 1/8" plywood **Bellcrank Mounting Plate** (CUB4W09). Assemble the 90 degree nylon bellcranks on each plate as shown in the sketch above. **NOTE:** The outer holes in each bellcrank must be drilled with a #49 (5/64") drill to ensure a good **slop-free** fit to the .074" diameter pushrod wires. **Apply epoxy to the bellcrank nut and bolt to prevent them from loosening but do not get epoxy on the bellcrank.**



❑ 15. Position the bellcrank mounting plates in the notches provided in the **#6** ribs with the bellcranks on the **bottom** side of the wing and securely glue them in place.

❑ 16. Cut two 24" long pieces of **Threaded Pushrod Wire** from the two .074" x 35" pushrod wires that are threaded on **both** ends (WIRES10). **NOTE:** Save the remaining pieces of pushrod wire for another step.

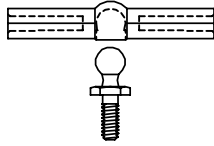
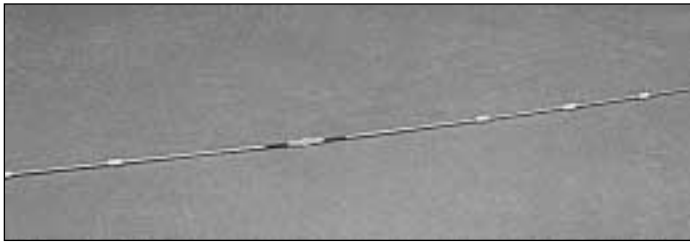

- ❑ 17. Cut eight pieces of the **Inner Pushrod Tube** (PLTB004) approximately 1/4" long to make the pushrod wire spacers. Slide four spacers on each of the 24" long pushrod wires. Space them out on the wire as shown on the wing plan. Add a very small drop of thin CA to each spacer to hold it in place. Thread each 24" long pushrod wire completely into the **Nylon Double Ended Ball Link** (NYLON55). Now back each wire **out** three full turns.



(Wing is right side up in photo.)

- ❑ 18. Slide the aileron pushrod assembly into the wing and snap the double ended ball link onto the metal ball.



- ❑ 19. With the servo arm in its neutral position, adjust each bellcrank so it is oriented as shown on the plans. Mark where each pushrod crosses the outer hole in each bellcrank. Be careful to not move the servo arm while marking the wires. Cut off each pushrod wire **5/16"** outside the marks you just made.

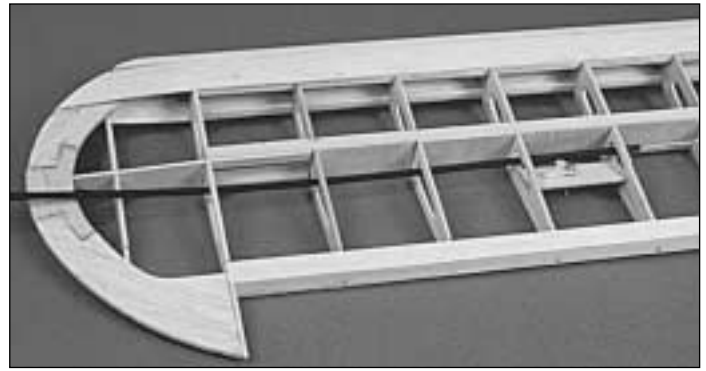

- ❑ 20. Cut the **36"** long **Outer Pushrod Tube** (PLTB011) into two **18"** long pieces. Scuff up the outer surface of each pushrod tube with 150 grit sandpaper so the glue will adhere better. Slide the 18" long outer pushrod tubes over each aileron pushrod wire.

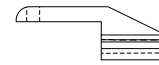

- ❑ 21. Unsnap the nylon double ended ball link and slide the pushrod assembly part way out of one wing panel. Bend that pushrod wire 90 degrees at the mark you made earlier. Try to keep the double ended ball link oriented properly during this bending process so you won't have to twist the wires later to get them into the bellcranks. Slide the pushrod assembly out the other wing panel and bend that wire 90 degrees also. Reposition the pushrod assembly in the wing and snap the double ended ball link onto the servo. Insert each bent portion of the wire into the two bellcranks and secure them with a nylon **Snap Keeper** (NYLON91) as shown in the photo. Remove the aileron servo from the wing for now.

Install LE and TE Sheeting

NOTE: In the next steps, maintain straightness by keeping each wing panel down against a flat surface while it is being sheeted.

- ❑ 1. Use your T-bar or other good flat sanding block to lightly sand the **top** edges of the ribs to smoothly blend them to the forward spar. Also remove any glue bumps or other irregularities along the leading and trailing edges.

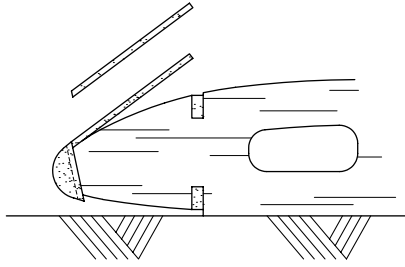

❑ 2. Prepare the 1/16" x 1-1/2" x 36" balsa **Top Leading Edge Sheeting** (CUB4W25) by sanding the front edge to a slight bevel so it will fit snugly against the LE (check by trial fitting).



❑ 3. Position the LE sheeting against the rear edge of the LE moving it left or right until it is just overlapping the #2 rib. Using thin CA, glue the front (beveled) edge of the LE sheeting to the LE.



❑ 4. Prop up the wing on its LE as shown in the photo. Apply a generous drop of thick CA to the top edge of each rib and allow it to flow down to the LE. Also apply a generous bead of thick CA to the top of the forward spar. Immediately lay the wing panel down on a flat surface and bend the LE sheeting down onto the ribs and forward spar. Hold the sheeting down with something flat (like a T-Bar or flat block of wood) until the glue cures. **It is important to keep the wing flat until the glue has cured or you may build a warp into the wing!**



❑ 5. Wet the LE sheeting with a wet paper towel from rib #7 to the end of the sheet. Form the sheeting down against the wing tip and glue along the LE and the edge of the wing tip. Hold the sheeting against the wing tip until the glue sets. Trim the sheeting even with the wing tip.

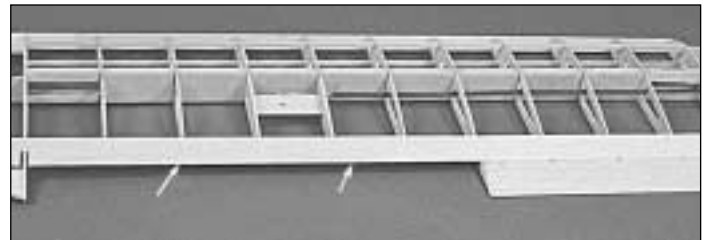

❑ 6. Place the 1/16" x 1-3/8" x 36" **Top TE sheeting** (CUB4W13) in place against the tapered TE so the inboard end of the sheeting is even with the wing centerline. Cut a notch in the TE sheeting at rib #7 to allow it to sit down onto the rib. Securely glue the sheeting in place and then trim it along the outboard TE and rib #7 just as you did for the bottom TE sheeting.

❑ 7. Lightly sand the **bottom** edges of the ribs to smoothly blend them to the bottom forward spar. Also remove any glue bumps or other irregularities along the leading and trailing edges. **Note: DO NOT** sand off the bottom of the rib behind the forward spar, because a "Step" must be maintained at the aft edge of the spar for the 1/16" sheeting. Examine the cross section on the wing plan before proceeding.

❑ 8. Install the 1/16" x 1-1/4" x 36" balsa **Bottom LE Sheeting** (CUB4W26) following the same sequence you used on the top LE sheeting.



❑ 9. Wet and form the bottom leading edge sheeting at the wing tip like you did the top leading edge sheeting. Glue the sheeting to the LE and the wing tip, then trim the sheeting and sand the entire tip as shown in the photo.

Install Center Sheeting

- ❑ 1. Use a sanding block to sand off any excess epoxy on the top and bottom of the spars in the center of the wing. Also **lightly** sand both the tops and bottoms of each rib to remove any glue bumps or other irregularities.

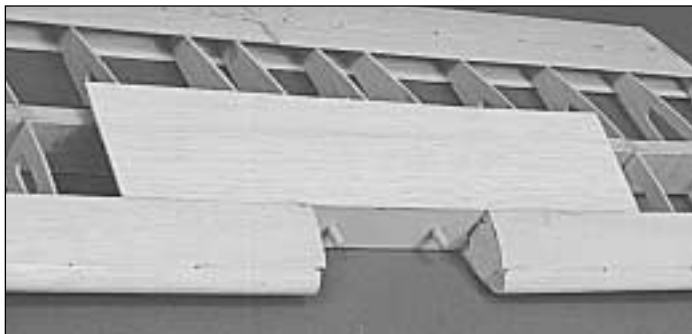

- ❑ 2. Mark a centerline on one of the 1/16" x 3" x 14-7/8" balsa **Center Sheets** (CUB4W14) lay the sheet against the back edge of the leading edge sheeting and mark the edge of the sheet on the ribs and spars. Remove the sheet and apply thick CA to the ribs and spars. Press the sheeting down and hold it in place until the glue sets.



- ❑ 3. Slide a second piece of top center sheeting up against the first piece and glue it in place. Cut a third piece to fill the gap between the second piece and the TE and glue it in place. Save the scrap from the third piece.



- ❑ 4. Use a 2-1/2" diameter circle template or the outline drawn on the plans as a guide for cutting a smooth radius at each corner of the top center sheeting as shown in the photo. Sand

the edges smooth with a piece of fine (220 grit) sandpaper. **Use extreme caution to avoid cutting into the spars!**



- ❑ 5. Trim a piece of the 1/16" x 3" x 14-7/8" center wing sheeting to fit between the spar and the **bottom** LE sheeting. It also must fit **between** the first two **#3** ribs as shown in the photo.



- ❑ 6. Glue the remaining piece of center wing sheeting behind the spar and use the scrap left over from the top of the wing to fill in to the TE. This sheeting also must fit between the first two **#3** ribs. Cut out between the **#1B** ribs for access to the aileron servo.



- ❑ 7. Cut the **Cap Strips** from the 1/16" x 1/4" x 30" (CUB4W15) balsa sticks to fit between the LE sheeting and the TE sheeting, and glue them to the **top** of each exposed rib.

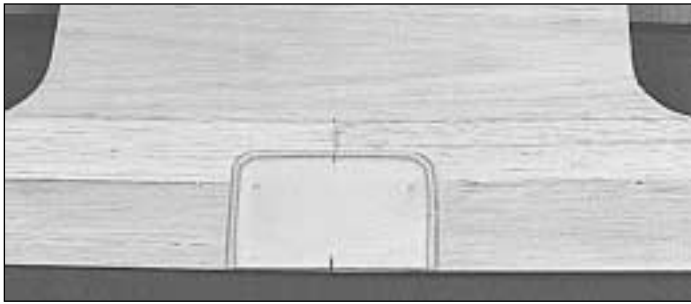

❑ 8. Sand the front and side **TOP** edges of the die-cut 1/16" plywood **Wing Bolt Plate** (CUB4W05) to a feathered edge. Leave the TE square. The top of the wing bolt plate has the embossed centerline and punch marks on it. Align the embossed centerline with the centerline of the wing and securely glue the wing bolt plate to the top of the wing TE so the punch marks are showing.

Build the Ailerons

❑ 1. Tape waxed paper over the aileron section of the wing plan.

❑ 2. Position the 3/32" x 2-11/32" x 18" balsa **Aileron Base** (CUB4W16) over the aileron view on the wing plan and carefully mark the **rib locations** on both sides of the aileron base using the guides printed on the plan.

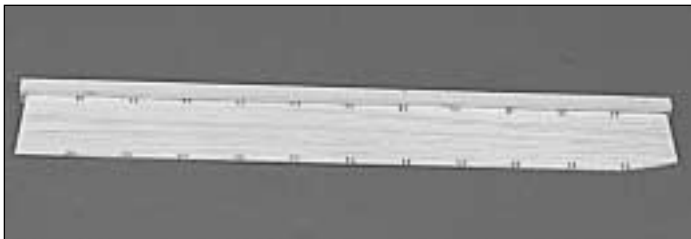

❑ 3. Slide the **Aileron Base** into the groove of the 3/8" x 5/8" x 18" grooved balsa **Aileron LE** (CUB4W17). Position the base so it is perpendicular to the face of the LE and glue it in place with thin CA.

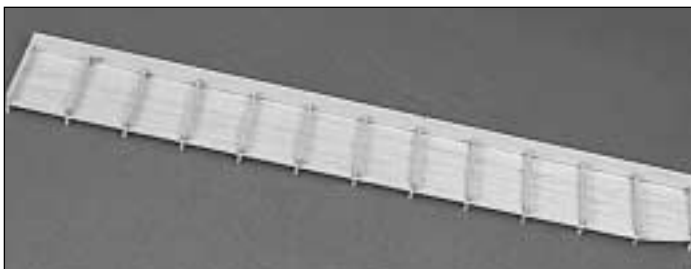

❑ 4. Cut the **Aileron Ribs** from the 3/32" x 1/4" x 30" balsa stick (CUB4W18). Glue the ribs to both sides of the ailerons lining them up with the rib locations you marked earlier. Make sure the ribs are perpendicular to the aileron base and tight against the LE.

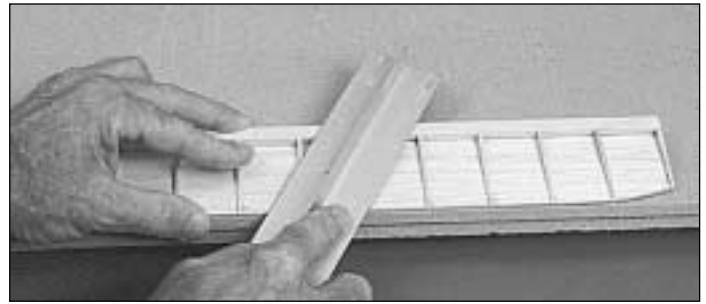

❑ 5. Use a razor plane and a T-bar or other good flat sanding block to shape the ribs to the cross section shown on the wing plan. As you can see on the cross section, the ribs should taper to nothing near the TE of the aileron.

❑ 6. Repeat steps 2 - 5 to make a 2nd aileron.

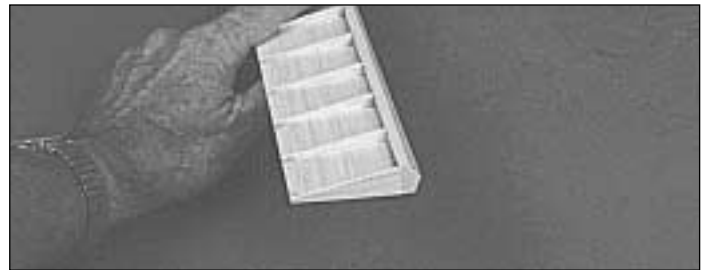

❑ 7. Draw an accurate **centerline** along the LE of the **ailerons** and the wing TE. Use a razor plane and a sanding block to shape the Aileron **LE** to the "V" shape shown on the aileron cross-section view on the wing plan. Sand the ends of the ailerons if needed.

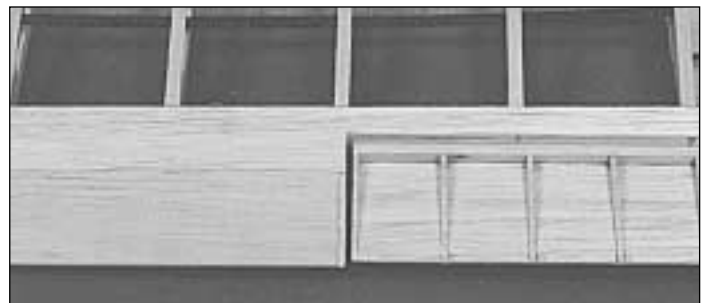

❑ 8. Designate one aileron as **Left** and write an "L" on it somewhere. Write an "R" on the other one. Test fit the Left aileron into the left wing panel and check to make sure there is approximately a 1/16" gap at both ends of the aileron. Sand the ends or add scrap balsa to the ends of the ailerons to adjust the width of this gap. Do the same for the Right aileron.



❑ 9. Glue the 1/4" x 1" shaped balsa **Aileron Control Horn Mounting Block** (CUB4W19) in place as shown on the

plans. This goes on the **bottom** of each aileron. Sand it to match the shape of the ribs.

Install Ailerons

NOTE: Do not glue the aileron hinges until after your model has been covered.

- ❑ 1. Lay the ailerons on the plan and mark the **hinge locations** on the ailerons. Center the ailerons in the wing panels and transfer the marks over to the wing TE.
- ❑ 2. Cut the hinge slots in the ailerons and wing TE using a hobby knife. (The suggested procedure was given on page 11).
- ❑ 3. Insert the hinges into the slots and trial fit the ailerons in place on the wing. **Do not glue the hinges until after you have covered the wing. NOTE: There should not be any hinge gap!**

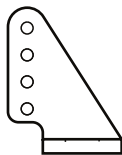
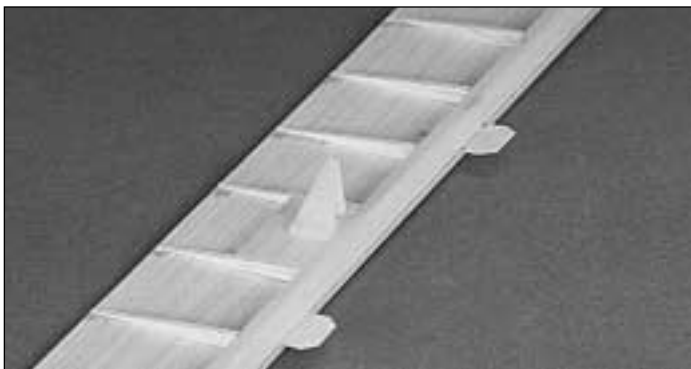

- ❑ 4. Position a **Small Nylon Control Horn** (NYLON03) on each aileron as shown in the photo and on the wing plan. Mark where to drill the mounting holes and remove the control horn.



- ❑ 5. Drill a **3/32"** hole at each mark and temporarily install the control horns using the **2-56 x 5/8" machine screws** (SCRW002) and the nylon **nutplates**. You may have to cut the aileron LE away slightly on the top to clear the control horn nut plate. Use either thick CA or epoxy to glue the nylon nutplate to the aileron, but do not get glue on the screws. Cut the excess screw off flush with the nutplate.

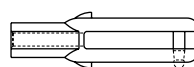

- ❑ 6. Reinstall the aileron servo and snap the double ended ball link in place. Screw a **Nylon Clevis** (NYLON17) with a clevis retainer onto the threaded end of the scrap **.074"** diameter pushrod wire section until the threads can be seen inside the clevis. Snap the clevis into the **outer** hole of the control horn and allow the pushrod to lay on top of the bellcrank. Tape the aileron in its neutral position. **NOTE: Slide the silicone clevis keeper onto the base of the clevis.**



- ❑ 7. With the aileron servo in its neutral position, mark where the pushrod crosses the outer bellcrank hole. Cut the pushrod off **5/16"** past that mark and then make a 90 degree bend at the mark. Insert the bent part into the bellcrank and secure it with a nylon snap keeper. Assemble the pushrod for the other aileron following the same procedure.



- ❑ 8. Cut eight **1/4"** wide x **1"** long pieces of scrap **3/32"** or **1/8"** balsa to use as aileron pushrod braces. Position them

against the aileron pushrod outer tube and glue them to several of the ribs as shown in the photo. Securely glue the outer pushrod tube wherever possible.

9. Adjust the length of the aileron pushrods if necessary (by twisting the clevises) to bring both ailerons into their neutral positions at the same time.

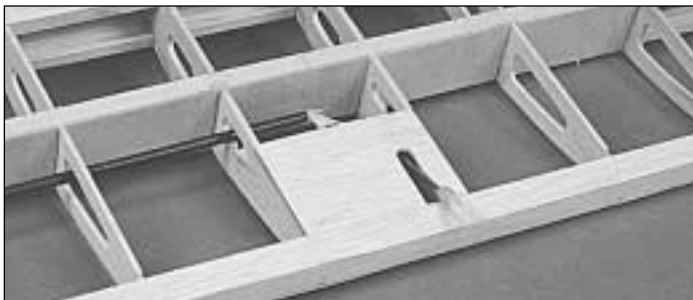

10. Position the die-cut 3/32" balsa **Aileron Pushrod Exit** (CUB4F08) in the notches on the bottom of the #6 ribs. Glue it in place and sand it to blend with the TE

FUSELAGE ASSEMBLY

Prepare Fuse Parts

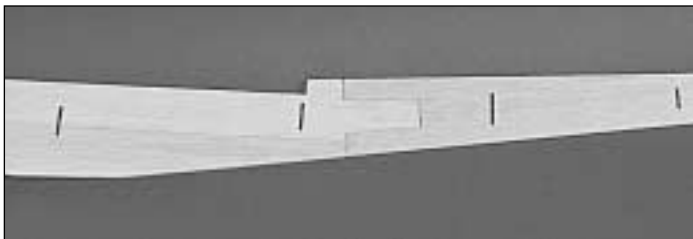

1. Pin or tape the fuse plan to a **flat** surface and cover it with waxed paper. Trial fit a die-cut 1/8" balsa **Upper Front Fuse Side** (CUB4F01), **Aft Fuse Side** (CUB4F02) and **Lower Fuse Side** (CUB4F03) together as shown in the photo. Sand them as necessary to achieve a good fit and glue them together with thin CA. **HINT:** You can also check the alignment of these parts using a straight edge along the lower aft edge of the assembly. Wipe off any excess glue with a paper towel (before it cures).

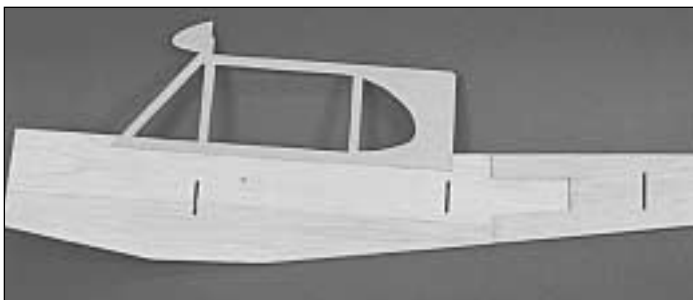

2. Glue a die-cut 1/8" ply **Cabin Side** (CUB4F04) to the fuse side.

3. Remove the fuse side from the plans and inspect the glue joints for gaps, adding thick CA glue to any open joints. Sand the glue joints smooth on both sides using a T-bar and 150-grit sandpaper.

4. Repeat steps 1 - 3 to build the other fuse side. Place the two assembled fuse sides together and sand the edges as necessary to make the two sides **identical**.



5. Glue a die-cut 3/32" balsa **Lower Fuse Doubler** (CUB4F06) to the fuse side. The front and lower edges of the doubler should be flush with the edges of the fuse side.



6. Glue a die-cut 3/32" balsa **Upper Fuse Doubler** (CUB4F07) in place. The front and top edges of the doubler should be flush with the edges of the fuse side.



7. Glue a die-cut 3/32" balsa **Aft Fuse Doubler** (CUB4F08) in place. It should line up with the fuse sides as shown in the photo.

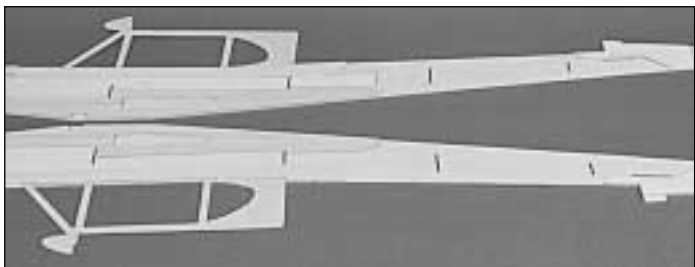

8. Go back to step 5 and add the remaining doublers to the other fuse side. **Be sure to make a Right and a Left side!**

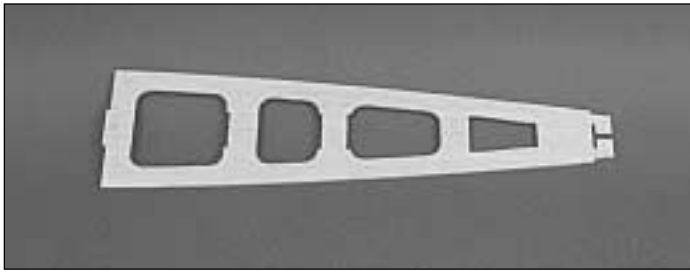

❑ 9. Test fit the two die-cut 1/8" balsa **Aft Fuse Tops** (CUB4F05) together. Sand them if necessary to achieve a good fit and glue them together as shown in the photo.



❑ 10. Use the aft fuse top to help position the die-cut 3/32" balsa **Cabin Doublers** (CUB4F08) as shown in the photo. The aft edge of the vertical slot (where the arrow is pointing) should be even with the aft edge of the cabin. Glue the doublers in place with thin CA.



❑ 11. Locate the die-cut 1/8" ply **Former F1A** (CUB4F04) and the die-cut 1/8" ply **Former F1B** (CUB4F11). Securely epoxy F1B to F1A so they are aligned with each other and the punch marks on F1A are showing. The kit has two F1A formers only one is used in the kit disregard the other.



❑ 12. If you are going to use the engine mount supplied with the kit, drill a 5/32" hole through the firewall at each of the four engine mount punch marks. If you are going to use a different mount, center it on the embossed lines and mark and drill the mounting holes.

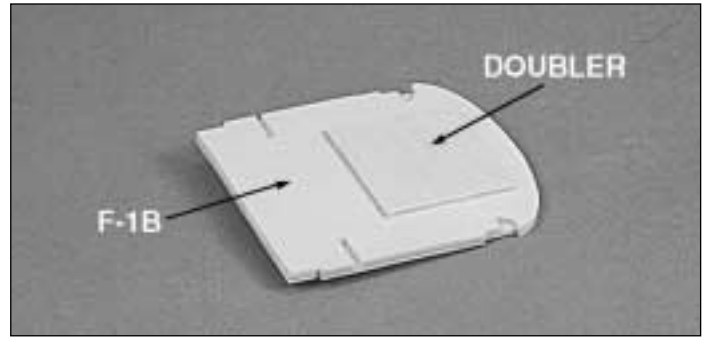

❑ 13. Glue one of the 1/8" x 2-3/8" x 2-3/8" ply **Firewall Doublers** (CUB4F18) to former **F1B** so that it is centered over the engine mount holes as shown in the photo. After the glue cures, drill the engine mount holes through the firewall doubler as well. **Note:** There are two Firewall Doublers included in this kit only one of them is used at this time (the other one may be needed later depending on the size of your engine).

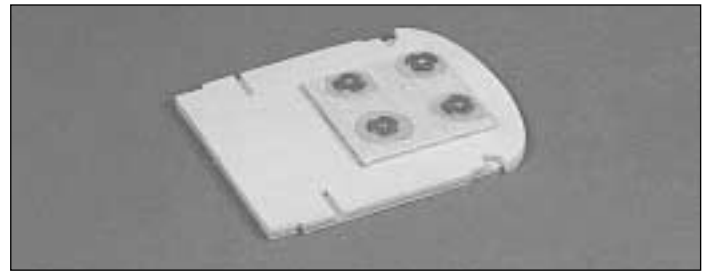

❑ 14. Insert the **#6-32 Blind Nuts** (NUTS003) into the engine mounting holes on the doubler. Tap the blind nuts in place with a hammer. Apply epoxy or thick CA to the blind nut flanges and the doubler to hold them in place. **NOTE:** Do not allow the glue to enter the threaded portion of the blind nuts.

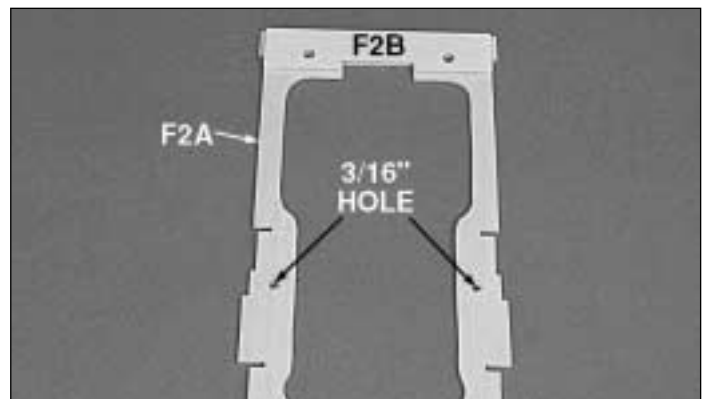

❑ 15. Glue the die-cut 1/8" ply **F2B** (CUB4F10) to the die-cut 1/8" ply **F2A** (CUB4F10) as shown in the photo. It is important to line up the wing dowel holes as precisely as possible. Drill a 3/16" hole at each of the punch marks on **F2A**.

❑ 16. Align the two die-cut 1/8" ply **Wing Mounting Blocks** (CUB4F12) with each other and securely glue the two together.

❑ 17. Drill a 3/16" hole at each of the punch marks on formers **F3**, **F4**, and **F5**.

Assemble Fuselage



❑ 1. Test fit **Former F2** in place on the left fuse side so that F2B is in front of F2A. Press it down into its slots and use a 90 degree triangle to keep it perpendicular to the fuse side. Glue it in place with thin CA.

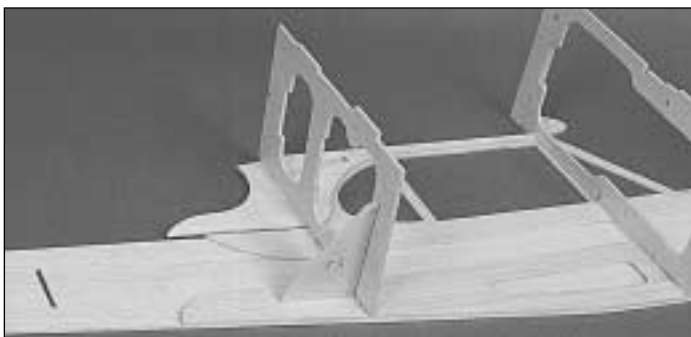

❑ 2. Test fit die-cut 1/8" ply **Former F3** (CUB4F11) in place on the left fuse side and use the die-cut 1/8" ply **F3 Angle Gauge** (CUB4F09) to properly slant it backwards. Make sure to install the former in the proper direction (see plans). **Tack** glue it in place with thin CA but do not glue the angle gauge in place. **Note:** You may have to sand off part of the lower tabs on the sides of F3 to permit the edge of F3 to rest fully down on the fuse side along its full length. If the tab protrudes through the fuse side it will contact the workbench before the edge of F3 contacts the fuse side.

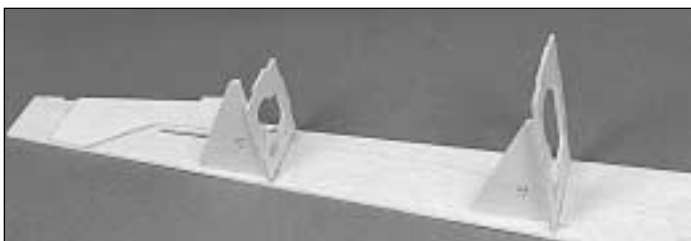

❑ 3. Position die-cut 1/8" ply **Formers F4** (CUB4F10) and **F5** (CUB4F12) in their respective slots on the left fuse side. Use the die-cut **F4** (CUB4F09) and **F5** (CUB4W07) angle gauges to slant them backwards. **Tack** glue F4 and F5 in place with thin CA. Do not glue the angle gauges to the fuse side. Do not apply glue to the joints near the **TOP** of former F3, because you will later (step 6) have to spread the fuse sides to install the wing mounting block.



❑ 4. Position the **right** fuse side in place so all four formers key into their slots. **Tack** glue the fuselage side to the formers. Do not apply glue to the joints near the **TOP** of former F3, because you will later (step 6) have to spread the fuse sides to install the wing mounting block.



❑ 5. Slide the 3/32" balsa **aft fuse top** that you assembled earlier into place and allow the formers to key into their notches. Make sure the fuselage is symmetrically lined up with the top and glue the top to the fuse sides and the formers. Glue the aft portion of the cabin doubler to the aft fuse top



❑ 6. Slide the laminated **Wing Mounting Block** into the notch in the cabin side doublers and lock the tab into **F3**. Securely glue it in place with epoxy. As you glue the wing mounting block in place, also securely glue the upper portion of Former F3 to the fuse sides.



❑ 7. Place the die-cut 1/8" ply **Lower Tank Floor** (LTF) (CUB4F09) into the bottom notches of former **F2**. Make sure the embossed letters are towards the **top** of the fuselage since this former helps set the correct right thrust. Glue the lower tank floor at the rear tabs only.

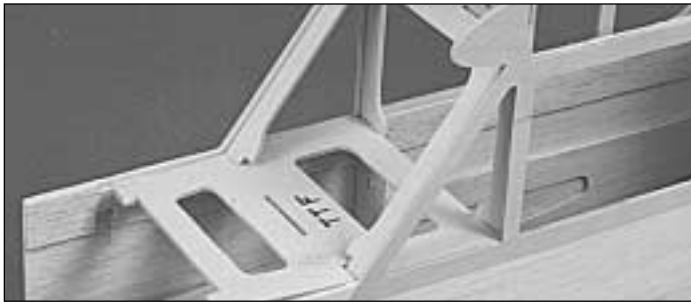

❑ 8. Insert the top tab of the die-cut 1/8" ply **Cabin Brace** (CUB4F12) into the notch at the bottom of former F2B. Insert the die-cut 1/8" ply **Top Tank Floor** (TTF) (CUB4F09) with the embossed "TTF" facing upward, rear tabs into the top notches of former F2. Allow the cabin brace legs to key into their notches in the top tank floor. Glue the top tank floor at the F2 notches only. LTF and TTF lay on the ledges formed by the fuselage doublers.



❑ 9. Press the firewall all the way onto the tabs at the front of both tank floors. Make sure it is properly seated on the tabs as this sets the correct amount of right thrust. Glue the firewall to the tank floors only.



❑ 10. Use good, stout hardwood sticks and multiple rubber bands to pull the fuse sides together. As you add rubber bands the fuse sides will gradually come together until they mate with F1. Make sure these parts fit together properly first, trimming as necessary, then remove some of the bands, Mix up some epoxy and apply it to the edges of the firewall and tank floors and add bands to pull the sides back into place. Wipe off any excess epoxy before it cures. **Immediately proceed to the next step.**

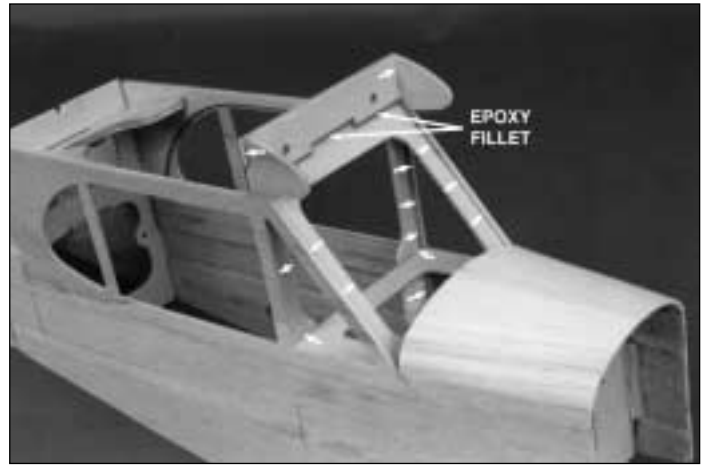

❑ 11. Go over all the joints, gluing them securely with medium CA. Pay special attention to all glue joints that involve Former F2. The arrows in the photo show the joints that require special attention. Apply a fillet of 5-minute epoxy to the joint where the Cabin Brace meets F2 and F2B. It is essential to have secure glue joints in these areas, as these components form the structure that holds the wing on. Avoid excessive buildup of glue in the areas where the side windows will be installed. Trim and sand off the tab at the top of the Cabin Brace where it protrudes behind F2.

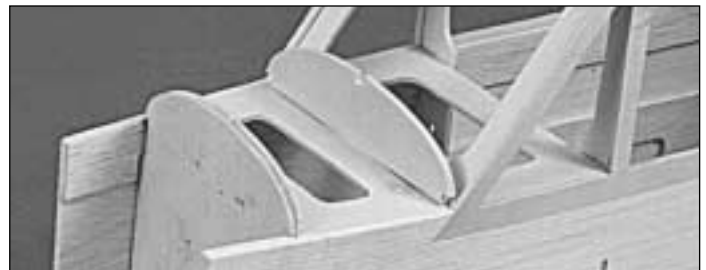

❑ 12. Press the die-cut 1/8" ply **Instrument Panel** (CUB4F04) into the slot on the top of the top tank floor. Hold it perpendicular to the tank floor and glue it in place. **Note:** Two Instrument Panels are included in this kit, only one is required.



❑ 13. Cut three **Stringers** from the 3/16" x 3/16" x 24" balsa stick (CUB4F14) to fit between the firewall and the instrument panel. Glue them in place with thin CA.



□ 14. Cut two 4-3/4" long sheets from the 3/32" x 3" x 12" balsa **Nose Sheeting** (CUB4F16). Glue one piece of sheeting to the right fuselage side and stringer so the corner of it is against the cabin side. Do not bend it around the firewall yet. Firmly apply two or three **15"** long pieces of strapping tape to the sheeting. Wet the outside of the nose sheeting with a paper towel and allow it to soak for about 5 minutes. Carefully pull the strapping tape around and stick it to the other fuselage side. Mark where the sheeting crosses the middle of the center stringer and release the strapping tape. Pull the strapping tape back enough to allow you to cut the sheeting on your marks. Pull the tape back to the other fuse side and glue the sheeting in place.



□ 15. Apply the remaining piece of nose sheeting on the other half of the nose, using the same technique described above. The nose sheeting must join at the middle of the center stringer. Trim the nose sheeting even with the instrument panel and the front of the fuselage sides.

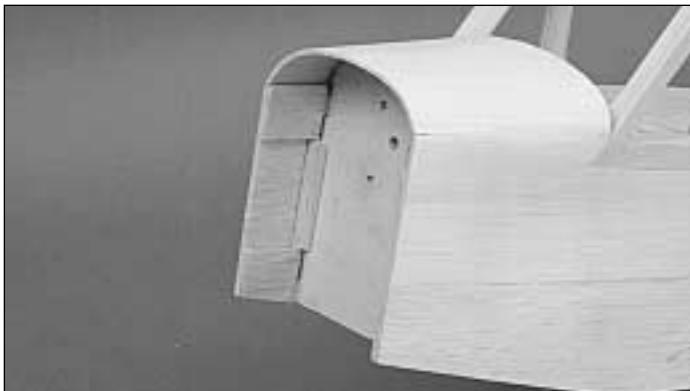

□ 16. Cut four **2"** long pieces of **1/4"** balsa **Triangle** (CUB4F24) and securely glue two of them to the front of the firewall, against the fuse sides and between the doublers as shown in the photo. Glue the other two to the backside of the firewall, similar to the two pieces in front.

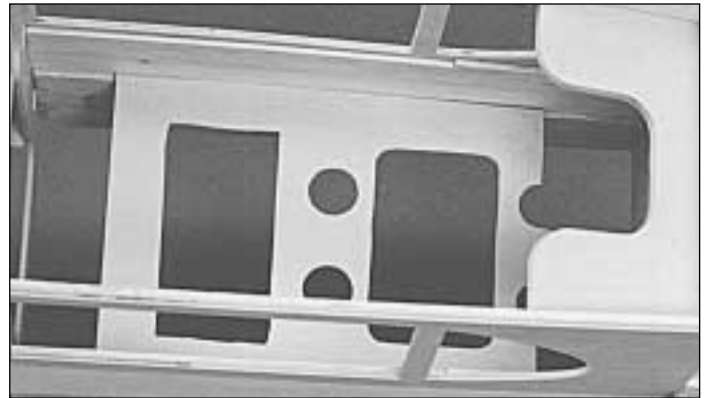

□ 17. Place the die-cut 1/8" ply **Servo Tray** (CUB4F12) in the fuselage on the ledges of the lower fuselage doublers as shown. If you are using a lighter 2-cycle engine, glue the tray as shown in the photo. If you are using a 4-cycle engine, slide the tray back against former F3 and glue it in place. Glue the two servo tray doublers (which were die-cut inside the servo tray opening) to the **bottom** of the servo tray at the front and back of the servo opening. **NOTE:** Do not glue the servo tray too far forward or you will not be able to get the receiver battery in under the lower tank floor.



□ 18. Scuff up the outside of the two **24"** long **Outer Pushrod Tubes** (PLTB011) with 150 grit sandpaper to help the glue stick to them. Slide them through the **rudder** and **elevator** pushrod holes in formers F3, F4, F5 and out through the slots in the fuselage sides. Position the tubes so they extend past the fuselage side approximately **2"** (to allow for trimming later). Cut the front of the tubes off approximately **2"** forward of former **F3**. If you would like to install a pushrod tube to route the receiver antenna inside the fuselage, slide another tube (not included) through the holes at the bottom of each former. It should extend to the aft edge of the fuselage sides. Securely glue the tubes to each of the formers and the fuse sides.

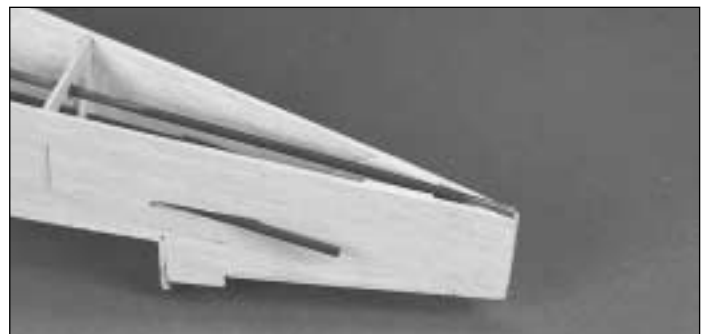

□ 19. Position the antenna tube near the bottom corner where the fuselage sides come together and glue it in place.

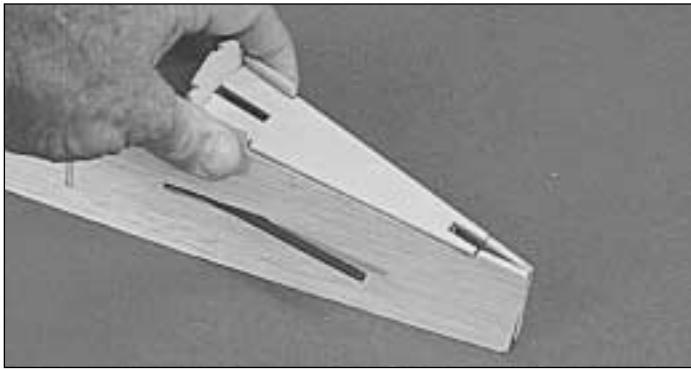

❑ 20. Insert the die-cut 1/8" ply **Top Deck Former #4** (CUB4F11) into its slot at the tail end of the balsa aft fuselage top. Slide the die-cut 1/8" ply **Stab Base** into its position behind TDF #4 so that it keys into the former. Pull the fuselage sides in to meet the former and stab base, and securely glue the **stab base only** in place. (**Note: Do not glue TDF #4.**) Remove the turtle deck former for now.

❑ 21. Go back and securely glue all formers by applying more thin CA, if needed, and then thick CA to each joint.



❑ 2. Place the **left** side of the engine mount on the mount spacer and center it on the diagonal lines you just drew. Mark the mounting holes on the diagonal lines and then drill a **3/16"** hole at each mark. **NOTE:** You will not glue this doubler to the firewall. It is used as a spacer only. Later, if you decide to change to a 4-cycle engine, you can easily remove the spacer.

❑ 3. Determine whether you want your engine side mounted or inverted. We recommend side mounting, but an inverted engine may allow you to use two dummy engines on the cowl. Screw the mount to the firewall using the **6-32 x 1" machine screws** (SCRW008) provided. If you are using a 2-cycle engine, place the 1/8" spacer you just drilled between the mount and the firewall.

Install Engine Mount and Fuel Tank

Note: The 1/8" Firewall Doubler (spacer) is used, as needed, to position the engine at the desired distance from the firewall. Depending on your engine size, you may have to use two or even three spacers to achieve the correct spacing. You may cut the extra die-cut firewall (CUB4F04) to 2-3/8" x 2-3/8" and use it as an extra spacer. The plans show the thrust washer at 5", but 5-1/8" is best. Do not glue these spacers in at this time. When you later fit the cowl, you may decide to adjust the fore-aft position of the engine slightly.

NOTE: If you are using a 4-Cycle Engine, skip to step #3.



❑ 1. Draw two lines on the 1/8" x 2-3/8" x 2-3/8" **Firewall Doubler** (CUB4F18) that extend from one corner across to the diagonal corner as shown in the photo. This spacer is not required for most 4-cycle engines.



❑ 4. Set the engine on the engine mount and measure from the firewall to the front of the thrust washer. Adjust the engine on the mount until the front of the thrust washer is **5-1/8"** [130mm] away from the face of the firewall. Mark the mounting hole locations on the mount. Remove the engine from the mount and accurately drill **7/64"** (or #36) holes. **NOTE:** If you have access to a drill press, use it for drilling these holes to insure that they are drilled vertically.

❑ 5. Now you may use one of the following methods to attach your engine to the mount:

❑ **Method 1:** Screw the **#6 x 3/4" sheet metal screws** (SCRW018), provided in the kit, through the engine mounting flange and into the mount. When first installing these screws, put a drop of oil into each screw hole.

❑ **Method 2:** Cut threads in the holes you just drilled using a 6-32 tap and tap wrench. If you use this method you'll have to supply your own bolts (6-32 x 1" socket head cap screws) for attaching the engine to the mount.

❑ 6. While the engine is still mounted, determine where the fuel lines and the throttle pushrod should pass through the firewall and mark these locations. **NOTE:** With most tank and engine combinations, the fuel lines can pass through the center of the mount.

❑ 7. Remove the engine from the engine mount and drill **1/4"** holes for the fuel line holes. Center the mount on the centerlines embossed on the firewall.

❑ 8. Cut two pieces of **1/4"** thick **foam rubber** (not included) to match the outline of tank floors. Glue one piece of the foam rubber to the top of the lower tank floor and the other to the bottom of the top tank floor.



❑ 9. We recommend a **10 oz.** fuel tank for use with .40 - .50 size engines. The smaller tank size makes routing the throttle pushrod easier. A **12 oz.** tank can be used with larger engines. Assemble your fuel tank and slide a section of standard size fuel line, approximately 20" long, onto the **fuel** nipple of the tank. With the tank inside the fuselage, feed the fuel line through one of the firewall holes and mark an **"F"** on the firewall to indicate that this is the fuel line. Mark a **"V"** near the other hole to indicate it will be the **vent** line. Feed the end of the line back through the other hole in the firewall and attach it to the tank vent.



❑ 10. Slide the fuel tank in between the two foam rubber sheets and gently pull the fuel line forward at the same time. **CAUTION:** Do not pull the fuel line hard enough to pull the line off of the tank. Seal the line holes with silicone sealer.

Final Fuselage Assembly



❑ 1. Test fit the **1/2" x 3/4" x 4-3/4"** basswood **Grooved LG Block** (CUB4F19) in the notches in the lower fuselage doublers. Enlarge the notches if necessary to get it to fit. Apply epoxy to the notches in the fuselage and the ends of the LG block and press it into place. Notice that the LG block is about **3/32"** lower than the edge of the fuselage to match up with the fuselage bottom sheeting.



❑ 2. Epoxy the two **1/2" x 3/4" x 1"** Basswood **Short LG blocks** (CUB4F20) in place above the grooved LG block as shown in the photo.

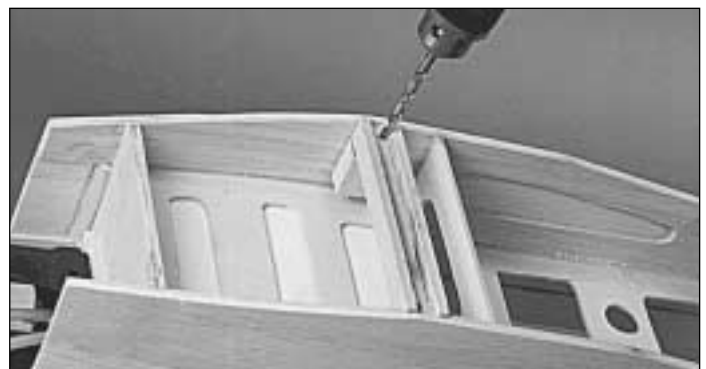

❑ 3. Refer to the plans and the photo above to determine where to drill the LG holes. One hole is near the aft edge of the groove and the other hole is near the forward edge of the groove. Both holes are centered approximately **3/8"** away from the fuselage side. Drill a **3/16"** hole through the grooved block and through the short LG block. Try to keep the drill perpendicular to the grooved block during this step.



❑ 4. Sand the bottom edges of the fuselage smooth with your sanding block. Use the 3/32" x 2-3/4" x 24" balsa **Bottom Sheeting** (CUB4F15) to sheet the bottom of the fuselage from the grooved landing gear block forward and from the landing gear block aft. **NOTE:** The sheeting is applied with the grain running across the fuselage. Trim and sand the bottom sheeting even with the fuselage sides and round off the bottom corners as shown on the fuselage cross-sections.

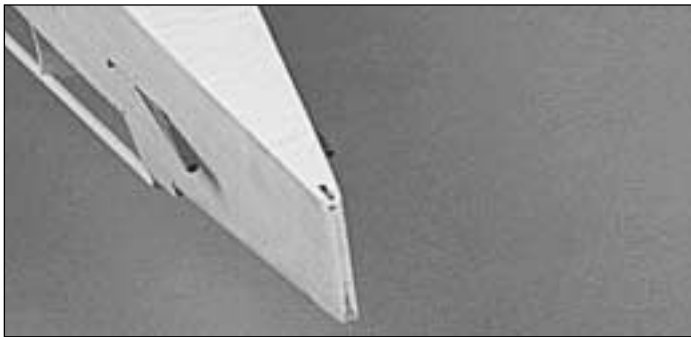

❑ 5. Cut a small opening in the bottom sheeting at the tail where the antenna tube meets the fuselage bottom.

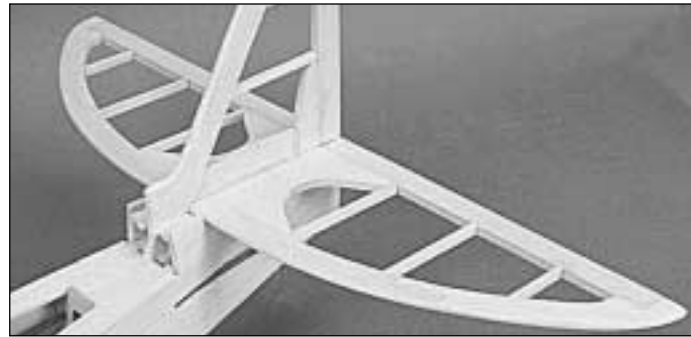

❑ 2. Test fit the stab/fin assembly onto the fuselage as shown in the photo. Trim or sand the slots if needed to get the stab to sit down onto the stab base. Even though this structure is self-aligning and should not require any adjustment, we recommend temporarily mounting the wing and verifying that the stab is straight with the wing. If there is any slop in the fin slot, double check the alignment. Remove the assembly and then use epoxy to securely glue it in place.



❑ 3. Replace turtle deck former #4 and glue it in place.

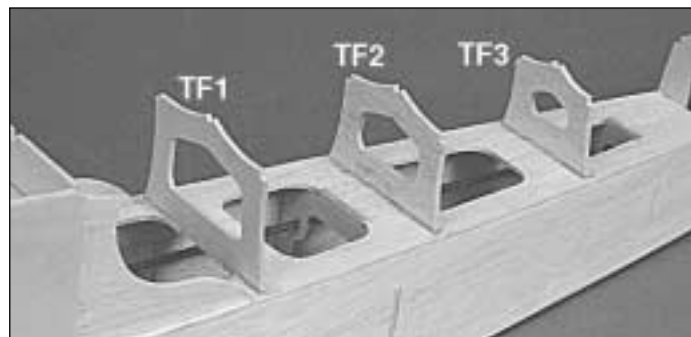

❑ 4. Install the remaining die-cut 1/8" turtle deck formers. **TF1** (CUB4F09) is **1/8" ply** and TF2 (CUB4F05) and TF3 (CUB4F03) are **1/8" balsa**. Glue them in place as shown in the photo.



❑ 5. Cut the 3/16" x 18" **Hardwood Dowels** (DOWEL044) to fit from the front edge of former **F3** to the aft edge of top deck former **#4** and glue them in place. Use strapping tape to hold them in place while the glue cures.

Mount Stabilizer and Fin

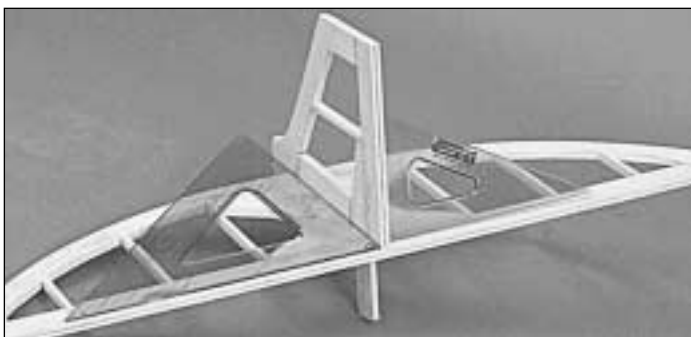

❑ 1. Slide the **Fin Post** into the slot in the stabilizer and check to make sure the fin will sit down against the stab. You may have to cut a notch in the back edge of the fin LE to get it to fit. Do not cut the stabilizer LE! Use a 90 degree triangle (or two) to keep the fin perpendicular to the stab and the stab TE. Securely glue the fin to the stab.



❑ 6. Refer to the fuselage plans to determine the placement of the 3/16" x 3/16" x 36" balsa **Fuselage Side Stringer** (CUB4F15). Cut a notch 6-1/4" from the front of each stringer to allow it to bend. Glue the stringer in place with thin CA. Round off the edges of the stringer with a sanding block so the it will look more like a tube after the covering has been applied. Also, taper the front and aft ends of the stringer as shown on the plans. **NOTE:** Use the exposed former tabs to help you position the stringer.

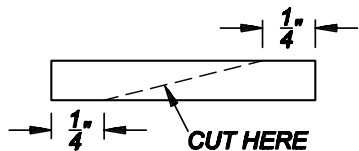

❑ 7. Cut two 1-1/4" lengths and two 2-1/2" lengths from what is left of the 3/16" x 3/16" balsa stringer (CUB4F13). Mark the 1-1/4" stringers as shown in the sketch. Cut each stringer on the diagonal line with a razor saw.



❑ 8. Place two diagonally cut pieces onto each of the 2-1/2" stringers as shown in the photo and glue them together as shown in the photo with thin CA. These will support the covering around the pushrod exits. **NOTE:** Be sure to make a **Left** and **Right** support.



❑ 9. Slide the support pieces in place against the fuse side stringer so the pushrods are surrounded by the supports. Glue the pieces in place with thin CA. Trim the pushrod outer

tubes flush with the covering supports. Sand a slight taper into the covering supports so they will not bulge the covering when it is applied.

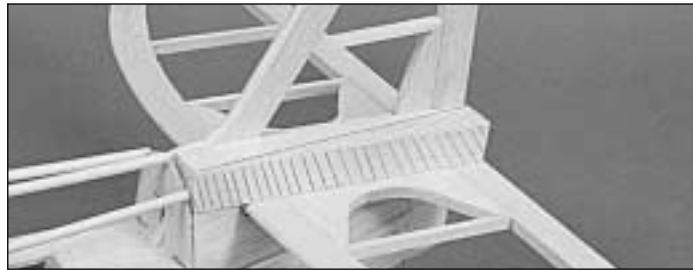

❑ 10. Place a 3/4" x 3/4" x 6-1/2" balsa **Tail Fairing Block** (CUB4F21) in each corner of the stabilizer and fin. Sand the forward ends of each block to fit against the turtle deck former. Mark a line on each block, from the outside edge of former F6 to the TE of the fin. Also mark the outline of the former TF4 on the front edge of each block.



❑ 11. Remove the blocks and shape them using a razor plane and sanding blocks. Use the lines you just drew as reference. Blend the rounded **forward** shape into the straight **aft** edge as shown in the photo.



❑ 12. Glue the blocks in place and final sand them to match former TF4 and the dowels. Sand the LE of the fin to blend with the center dowel and the fairings. Fill any gaps with HobbyLite™ filler.

❑ 13. Glue a 1/4" x 1/4" x 2-1/2" piece of scrap balsa wood in each of the fuselage corners behind former **F2**. See plans. These blocks will give support for the screws in step 5 of this page.

Install Main Landing Gear

TOE-IN

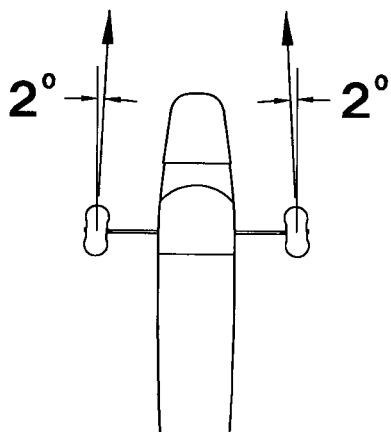

- ❑ 1. Using a flat file, chamfer the ends of the main landing gear wire to remove any sharp edges. **Note:** For best ground handling, the main landing gear should have one or two degrees of "toe-in." Check this by sighting across from one axle to the other. If it looks like the wheels will toe-out, try reversing the landing gear wires to the opposite sides. It may be necessary to put the wires in a vise and bend them to produce the toe-in.



- ❑ 2. Insert the landing gear wires into the grooved landing gear block on the bottom of the fuselage. The landing gear wires lay side by side in the grooved block and flush with the surface of the grooved block. You will have to carve the corners of the holes out slightly to get the gear to fit down all the way.

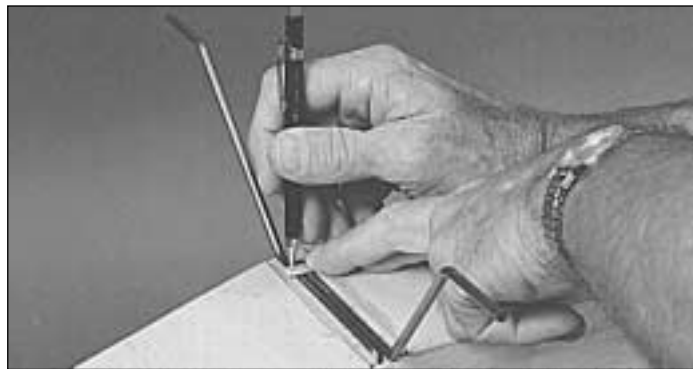

- ❑ 3. Position **Nylon LG Straps** (NYLON36) over the landing gear wire approximately 1" from the bends in the landing gear wires. Mark the locations of the mounting screws on the grooved block. Drill a 1/16" hole at each of these marks.



- ❑ 4. Secure the landing gear straps to the grooved block with the **#2 x 3/8" sheet metal screws** (SCRW024). **NOTE:** The landing gear wires should be removed before the covering is applied.

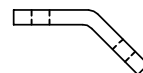

- ❑ 5. Position the die-cut 1/8" plywood **Landing Gear Fairings** (CUB4F04) over the landing gear wires as shown in the photo. Use a pliers to bend four nylon **Landing Gear Straps** (NYLON36) as shown in the sketch. Mount the nylon straps to the fairings with four **#2 x 3/8" Sheet Metal Screws** (SCRW024). Mount the nylon straps to the fuselage with four **#2 x 1/2" Button Head Screws** (SCRW088) as

shown in the photo. Cut the protruding part of each #2 x 3/8" screw off on the outside of the fairings and sand (or file) the screws flush with the fairing. Use a small rubber band near the wheel end of the fairing to allow the strut to move against the fairing. Remove all the screws and apply thin CA to each of the holes to harden the wood. You can leave the fairings off until after the plane is covered.



Mount the Wing to the Fuse

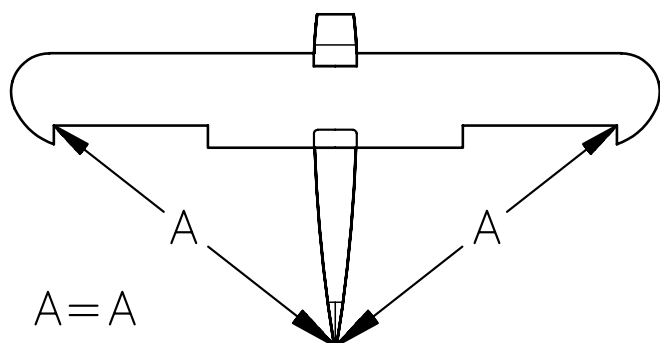

1. Lightly sand the entire wing saddle area to remove any glue bumps. Place the wing in the saddle and carefully **align** it by measuring from the end of rib #7 to the TE of the rudder on both sides of the plane. Adjust the placement of the wing until both measurements are equal. Make a mark on the wing TE and the center dowel to help keep things aligned. While holding the wing in its proper position (a couple pieces of strapping tape will help), drill **1/4"** holes at each of the punch marks in the 1/16" ply wing bolt plate. Keeping the drill perpendicular to the ply wing bolt plate, drill through the wing TE and the two 1/8" ply wing mounting plates in the fuselage. **IMPORTANT! Do not allow the wing to move while drilling.**

2. Remove the wing and enlarge the holes in the fuselage wing mounting plate **only** to 5/16".

3. Insert the two **1/4"-20 Blind Nuts (NUTS020)** into the 5/16" holes in the wing mount plate from the bottom side. Press the blind nuts into place with a pliers. Trial fit the wing to the fuse using the two **1/4-20 Nylon Bolts (NYLON13)** provided. Do not over-tighten the bolts. If everything fits nicely, remove the wing and apply epoxy around the blind nuts to hold them in place. Use care to avoid getting glue on the blind nut threads. You may also cut the nylon bolts off so they protrude about **1/4"** below the blind nuts.



4. Using a scissors, carefully cut the windshield along the trim line. Trial fit the windshield onto the fuse, and trim it as necessary for a good fit. **NOTE:** Do not glue the windshield in place until after you have covered your model.



5. Replace the wing on the fuselage and measure the gap between the wing and the windshield. Glue scrap pieces of balsa sheeting to the wing to reduce this gap to **1/32"**. Sand the scrap balsa to the contour of the wing.

Install Servos, Horns and Pushrods



❑ 1. Hold the **Large Nylon Control Horns** on the elevator and rudder in the positions shown on the fuselage plan and mark the mounting hole locations. **REMEMBER:** The elevator horn is located on the **bottom** of the elevator! Drill 3/32" diameter holes at these locations. Mount the control horns with 2-56 x 5/8" screws (SCRW002) and the nylon **nutplates** which were attached to the horns.

❑ 2. Temporarily mount the rudder and elevators to the fin and stabilizer using the hinges provided.

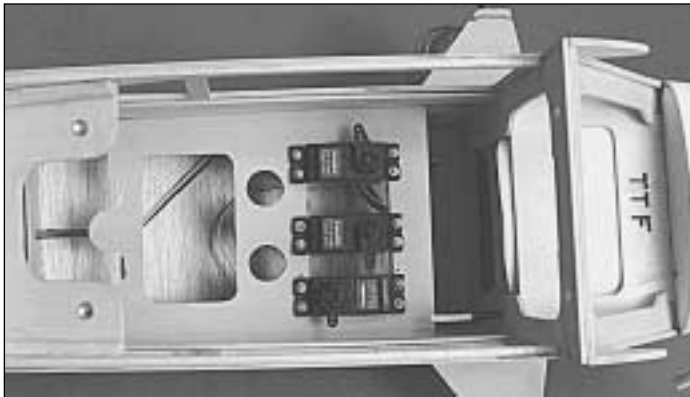

❑ 3. Mount three servos in the servo tray, using the screws provided with the radio, as shown in the photo. Cut off all but one arm on three large servo horns and install one on each of the servos.

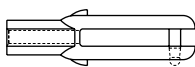
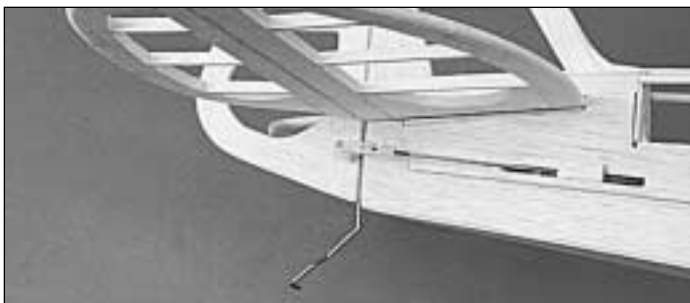

❑ 4. Thread a nylon clevis with a clevis retainer onto each of the two **36"** long Rudder and Elevator **pushrod wires** (WIRES17) until the threads are visible inside the clevis. Insert the pushrod wires into the pushrod guide tubes (previously installed) and attach the clevises to the elevator and rudder horns.

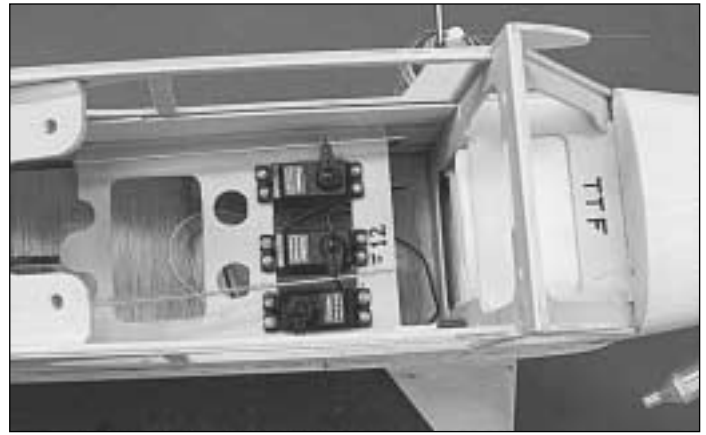

❑ 5. Tape the rudder and elevators in their **neutral** positions and mark where the pushrod wires cross the holes in the servo wheels with a permanent fine tip marker. Disconnect the rudder and elevator clevises from the control horns and remove the pushrod wires from the tubes. Cut the pushrod wires off 5/16" past the marks you just made.

❑ 6. Cut twelve **1/4"** long pieces of 1/8" diameter inner pushrod tube. Slide six of these "spacers" onto each of the long pushrod wires and space them as shown on the fuse plan. **NOTE:** If these spacers do not slide on easily, cut them to a shorter length. Also, while installing the pushrods, position the above plastic tube spacers so they always stay inside the pushrod guide tubes. If the tubes are not a tight friction fit on the pushrod wires, apply a very small drop of thin CA to secure them.

❑ 7. Replace the pushrod wires in the guide tubes and make a 90 degree bend at the marks you made earlier. Insert the bent portion of each wire in the correct servo horn and secure it with a snap keeper. **NOTE:** You will probably have to enlarge the holes in the servo horns with a 5/64" drill bit. **NOTE: The THROTTLE PUSHROD location will vary, depending on the engine used. Plan your installation carefully!**

❑ 8. With the engine attached to the mount, determine the best routing for the **throttle pushrod**. The pushrod should be located as close as possible to the fuse side (to allow room for the fuel tank), and it should not have any tight bends. Drill a hole in the firewall and F2A for the throttle pushrod guide tube (not included).

❑ 9. Install the throttle pushrod following the engine manufacturer's instructions and hook it up to the servo on the right side of the plane as shown on the plans. See photo at step 1 on page 40.

❑ 10. Hook up your radio system and test the operation of all three controls.

These are the recommended control surface throws (NOTE: Throws are measured at the widest part of the elevator and rudder.):

	High Rate	Low Rate
ELEVATOR:	1-1/8" [29mm] up 1-1/8" [29mm] down	5/8" [16mm] up 5/8" [16mm] down
RUDDER:	1-3/8" [35mm] right 1-3/8" [35mm] left	1" [25mm] right 1" [25mm] left
AILERONS:	3/4" [19mm] up 11/16" [17mm] down	1/2" [13mm] up 7/16" [11mm] down

***NOTE: These control surface "throws" are approximate and provide a good starting point for the first flights with your Piper Cub. You may wish to change the throws slightly to provide the smoothness or quickness that you prefer. Increased elevator throw may be required for spins and snap rolls.**

FINAL ASSEMBLY

Install Wing Struts (Optional)

NOTE: The wing struts are for scale appearance only. Built according to the plans and instructions, the airframe has sufficient strength for normal aerobatic flying without the struts. Before proceeding, make sure that you have the wing seated and installed on the fuselage in its final position. However you must use the struts to fly your cub if it is covered with anything other than MonoKote.

- ❑ 1. Refer to the fuselage plan and, by measurement, mark the **wing strut strap** locations on the fuse sides.
- ❑ 2. Sand all surfaces and the LE and TE of the shaped basswood **Struts** (STRUT001) smooth.
- ❑ 3. Bend six nylon straps with pliers just as you did earlier for the landing gear fairings.

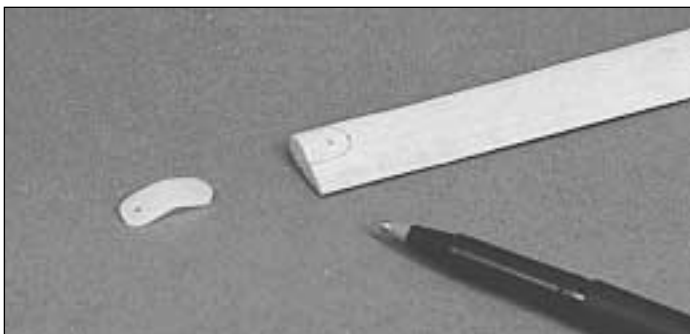

- ❑ 4. Place a nylon strap on the outboard end of each strut so that 1/2 of the strap overhangs the end of the strut and

trace around the strap. **NOTE: Make two Right and two Left struts and keep in mind that these straps are on the top of the outboard end of the struts.**

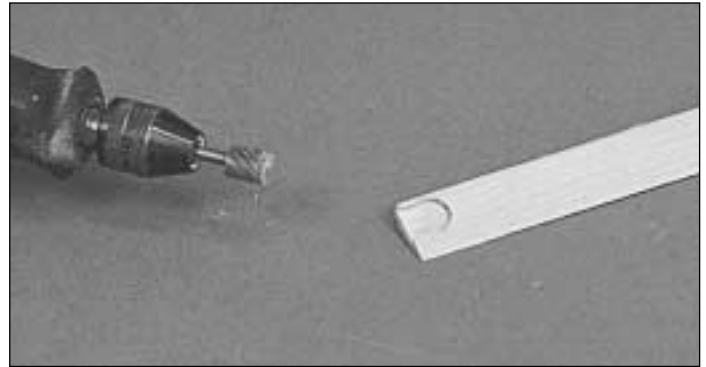

- ❑ 5. Cut out the marked area **3/32"** deep so the strap is recessed into the end of the strut. Test fit the nylon strap into the recessed area and check for the fit. The strap should be slightly below the strut surface. A Dremel tool works well for this.

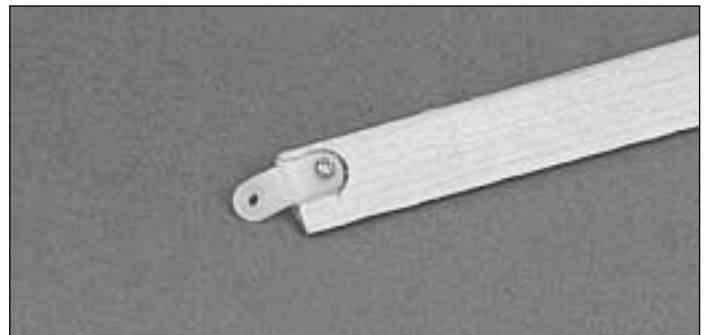

- ❑ 6. Drill **1/16"** holes and mount a strap to each strut using **#2 x 3/8" sheet metal screws** (SCRW024). Apply thick CA to each strap to help hold it securely in place. Cut and file off the pointed tip of each screw so it is flush with the surface of the strut.

IMPORTANT: Follow steps 7-11 in their exact sequence, to avoid ending up with a locked-in wing twist.

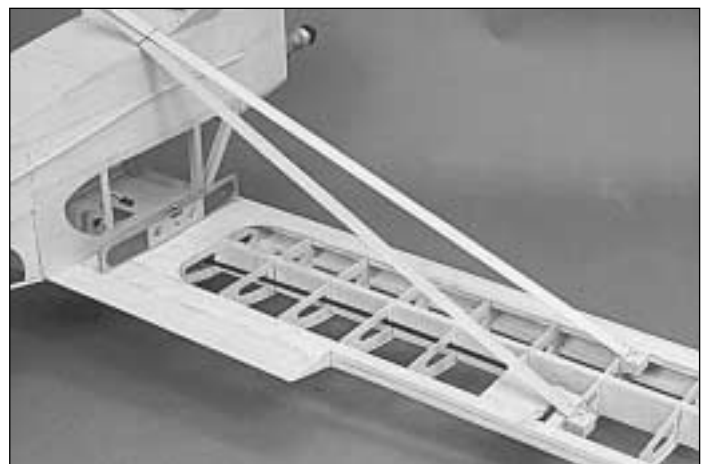

- ❑ 7. Lay the assembled airframe upside down on the work surface and support the center of the wing so the wing tips are not touching anything. Use a bubble level placed near the fuselage to adjust the attitude of the plane until the **bottom**

of the wings are level. Drill a **1/16"** hole in the middle of each wing strut mounting block and screw a strut to each block using a **#2 x 1/2" Button Head Screw (SCRW088)**. Mark where the struts cross the fuse side and cut them off at the marks. Replace the struts and check their fit.



❑ 8. Bring the unfinished ends of the struts together at their proper location on the fuselage and draw a line on the front strut where the aft strut crosses it. Remove the front struts and cut away behind the lines you drew on them.

❑ 9. Cut and sand the inner ends of the **Aft** struts to provide a **1/16"** gap between the ends of the struts and the fuselage. Place a nylon strap on the outboard end of each aft strut, so that 1/2 of the strap overhangs the end of the strut and trace around the strap. Cut out the marked area and mount the straps to the struts with a **#2 x 3/8"** sheet metal screw following the same procedure you used earlier. Cut off each screw so it is flush with the surface of the strut.

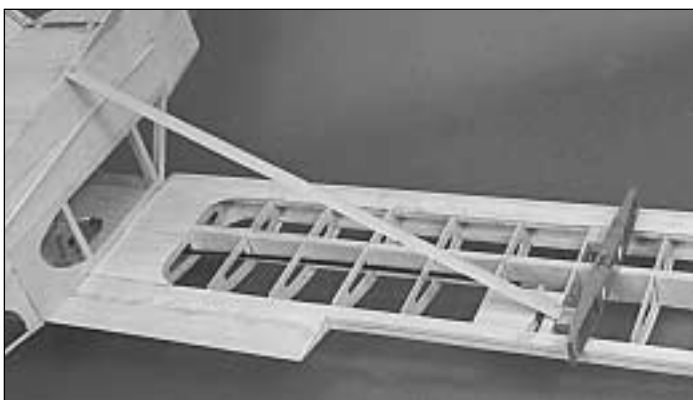

❑ 10. **IMPORTANT** - Move the bubble level out near the **#6** ribs and twist the wings if needed to make the bottom of the wing level during this step. **DO NOT CHANGE THE ATTITUDE OF THE FUSELAGE.** Position the aft struts near their attachment points on the fuselage and check to make sure the wing is still level. Mark where to drill the mounting holes and drill a **5/64"** hole at each mark. Enlarge the strap hole with a **1/8"** drill and screw the nylon straps to the fuselage with the **#4 x 5/8"** sheet metal screws (SCRW010) provided.



❑ 11. Replace the forward struts using the #2 screws and test fit them against the aft struts. Trim and sand the joint if necessary to achieve a good fit between the two struts. Again, check the level to make sure the wing is not twisted and when satisfied with the fit, glue the struts together with thick CA or epoxy.



❑ 12. Remove the struts and apply **thin** CA to the holes in the fuselage to harden the wood. Apply a filler (automotive body filler works well) to fill the joint between the struts and to fill over the attaching straps. Sand the filler to blend the joints and cover the nylon straps.

Install Receiver, Switch and Battery

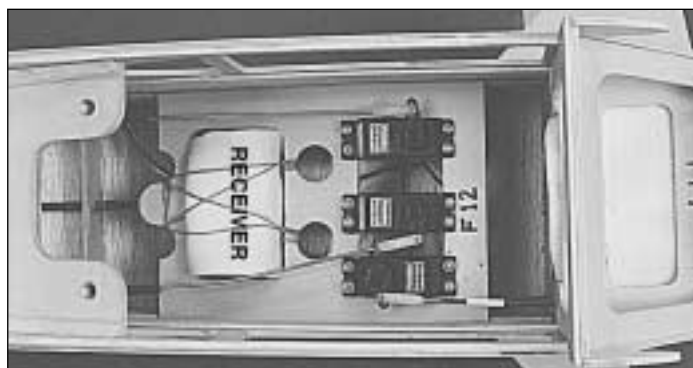

❑ 1. Hook up the radio system following the radio manufacturer's instructions. Plug an aileron extension into the aileron slot in the receiver and route the extension up near the wing mounting plate. Wrap the receiver in 1/4" - 1/2" of foam rubber to protect it from vibrations. Secure it to the servo tray with rubber bands as shown in the photo. Use four rubber bands underneath the receiver and four above it to support it. **NOTE:** You should replace these rubber bands if they show signs of deteriorating or breaking.

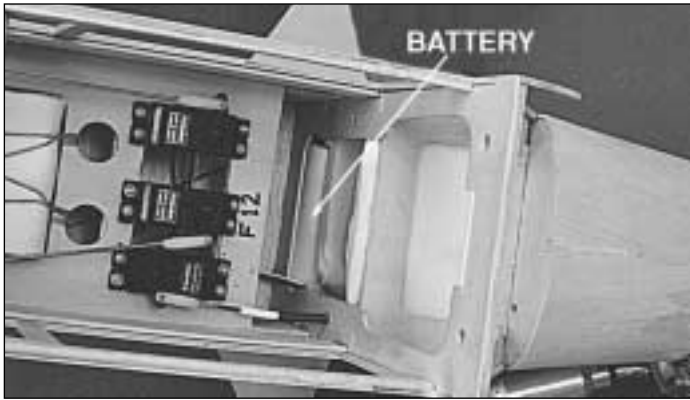

❑ 2. Wrap the **Battery** in a plastic bag, surround it with latex foam rubber and slide it under the die-cut lower fuel tank floor. **NOTE:** If your plane happens to be a little nose heavy, you can move the battery to a different location.

❑ 3. Route the receiver antenna through the center pushrod guide tube if you used one, and out of the fuse bottom. If you did not install an antenna tube, route the antenna out near the TE of the wing and attach it to the vertical fin using a small rubber band.



❑ 4. Mount the on-off switch wherever convenient. We used the Great Planes Switch and Charge Jack Mounting Set (GPMM1000) which makes it very easy to charge the battery and it looks great. The switch can be mounted on the bottom of the fuselage opposite the exhaust as long as the exhaust will not blow onto the switch.

Install Cowl



❑ 1. Using a hobby knife, Lexan® scissors or a Dremel® Moto Tool® with a pointed bit, carefully trim around the base of the cowl. Also, cut out the three openings in the front of the cowl for air intakes and the engine thrust washer.

❑ 2. Without the engine on the fuselage, test fit the cowl in place. Round off the corners of the fuselage to obtain a good fit. When satisfied with the fit, install the engine and mount.

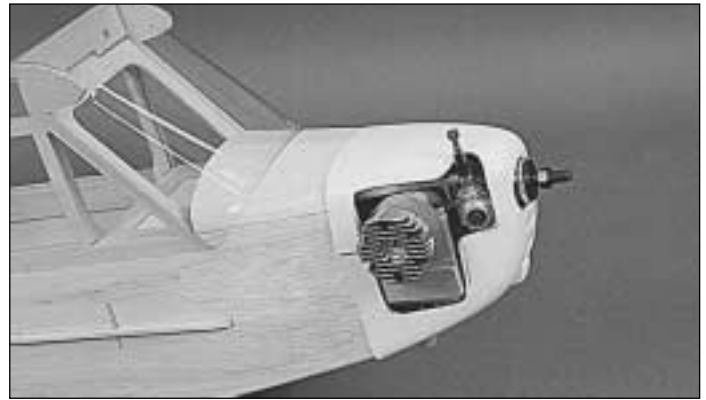

❑ 3. Cut the openings in the cowl for the engine head, needle valve and exhaust pipes. This step requires patience, so cut a little bit, test fit and cut a little more. Do not try to cut a lot at once because every cowl will fit a little differently. Allow approximately **1/8"** clearance all around the engine head and muffler for cooling air flow. Position the cowl so there is at least **1/8"** clearance between the front of the cowl and the prop. It is sometimes easier to take the muffler off during the early stages of fitting and get the cowl to fit the engine itself first. Then cut the cowl until the muffler will fit in place. **NOTE:** Carefully monitor the temperature of the engine during the first few test runs. Look for signs of the heat melting the cowl or affecting the performance of the engine. Cut larger air flow holes (both inward flow and outward flow) if needed to keep the engine sufficiently cool.



❑ 4. Determine where the best places are to screw the cowl in place. We have included six **#2 x 3/8"** sheet metal screws which you can install as you desire. Different engine/muffler

combinations will determine where the screws should be installed. In any case, keep the screws approximately **3/8"** forward of the aft edge of the cowl. Tape the cowl in place so it does not move and drill a **1/16"** hole for each screw.

5. Remove the cowl and enlarge the holes in the **cowl only** to **3/32"**. Glue a 1/8" x 1/2" x 3/4" ply **Cowl Screw Block** (CUB4F22) to the inside of the fuselage at each screw location. Extend the **1/16"** holes through the ply screw blocks.

6. **OPTIONAL STEP** - To help extend the life of your cowl, roughen the **inside** surface of the cowl (around the cowl mounting holes) with coarse sandpaper. Apply a layer of lightweight fiberglass cloth over each hole using epoxy or CA. Do not use polyester resin as it will melt the plastic. Let the epoxy thoroughly cure, then re-drill the mounting holes.

7. Sand the entire outside surface of the cowl lightly with 400 grit sandpaper. Spray on a coat of primer, then sand smooth with 400 grit sandpaper. Paint the cowl with fuelproof paint. We used Top Flite Cub Yellow LustreKote.



HINT: Access to the fuel lines can be a problem in a cowed engine; therefore, we suggest that you install a Great Planes Easy Fueler (GPMQ4160) valve. This makes it much easier to fill and empty your tank.

Additional Fuelproofing

If you have not already done so, make sure the entire engine compartment is completely fuelproof. Also fuelproof any wood that will not be covered and which may be exposed to glow fuel residue. Use epoxy thinned with alcohol, polyester finishing resin or fuelproof paint.

Balance the Airplane Laterally

NOTE: Do not confuse this procedure with "checking the C.G." or "balancing the airplane fore and aft". That very important step will be covered later in the manual.

Now that you have the basic airframe nearly completed, this is a good time to balance the airplane **laterally** (side-to-side).

1. Temporarily attach the wing and engine (with muffler) to the fuselage.

2. With the wing level, lift the model by the engine propeller shaft and the bottom of the fuselage near the aft end (this may require two people). Do this several times.

3. If one wing always drops when you lift, it means that side is heavy. Balance the airplane by gluing weight to the other wing tip. **NOTE: An airplane that has been laterally balanced will track better in loops and other maneuvers.**

Final Sanding

Check over the entire structure carefully, inspecting for any poorly glued joints, gaps and "dings". Apply additional glue and/or balsa filler as necessary, then sand the entire structure smooth using progressively finer grades of sandpaper.

Covering

Because it is assumed that you have had some previous model building experience, we won't go into detail in regard to the covering procedure. **Follow the instructions included with your covering material.**

NOTE: When covering the fin and stab, begin by applying 1/2" wide strips of covering in the corners between the fin and stab, and (on the bottom of the stab) between the stab and the fuse sides. Next, cover the stab and fin with pre-cut pieces that have a straight edge to overlap (1/8"+ overlap) the strips you previously applied. DO NOT, under any circumstances, attempt to cut the covering material after it has been applied to the fin and stab, except around the leading and trailing edges and the tip. Modelers who do this often cut through the covering and part-way into the balsa stab. This can weaken the stab to the point where it may fail in flight! Also note that when the sides are covered, the covering material should be ironed only to the bottom of the window cut-outs to the top of the fuselage side. This will give the appearance of the open tube fuselage structure found on the full size Cub.

Recommended Covering Sequence:

- 1. Strips as described in above note
- 2. Rudder left side

- 3. Rudder right side
- 4. Bottom of elevators
- 5. Top of elevators
- 6. Stab bottom
- 7. Stab top
- 8. Fuse bottom
- 9. Fuse sides
- 10. Fuse top
- 11. Fin left side
- 12. Fin right side
- 13. Bottom of ailerons
- 14. Top of ailerons
- 15. Aileron openings in wing
- 16. Bottom of left wing panel
- 17. Bottom of right wing panel
- 18. Top of left wing panel (overlap covering 1/4" at wing LE)
- 19. Top of right wing panel (overlap covering 1/2" at the center and 1/4" at the LE)
- 20. Landing Gear Fairings

Apply Decals and Trim

NOTE: The decal sheet includes the items you need to trim your model as shown on the box.

- 1. Study the photos on the box to determine where to place the decals.
- 2. Thoroughly clean your airplane before applying decals.
- 3. Cut out the individual decal items and apply them in the locations shown on the plan. **HINT:** To apply decals accurately, peel only a small portion of backing from one end, cut off the backing with a scissors, position the decal carefully, press down the exposed portion of the decal, peel off the rest of the backing, then (working from the already stuck down end) carefully press down the rest of the decal.
- 4. From Chrome MonoKote or MonoKote Trim Sheet, cut out a rectangle and apply it to the top of the wing to represent the top window.

Glue the Hinges

- 1. Lay the rudder, elevators and ailerons on the plans and mark on the leading edge of each part the locations of the hinges, and tailgear. Now use a sharp hobby knife to cut slits in the covering at the hinge locations. Trial fit the hinges to make sure you have "found" the slots which you previously cut. In the same manner, slit the covering at the hinge locations in the wing, stab and fin TE. Also cut the covering away from the tailgear slot. Trial fit the elevator to the stab with the hinges installed. Fit the rudder to the model and with a pencil, mark the location where the 1/8" wire elevator joiner interferes with the rudder. Remove the rudder and with a hobby knife or file, cut a clearance notch for the 1/8"

wire elevator joiner. Reinstall the rudder and check the notch. The notch should be large enough to allow the rudder to freely move throughout its entire range of motion.

- 2. Using coarse sandpaper, roughen the horizontal part of the tailgear wire, then clean off the sanded portion of the wire with alcohol or a degreasing solvent. Using a toothpick, apply a small amount of Vaseline where the tailgear wire enters the nylon bearing tube (to prevent glue from getting inside and locking them up).

- 3. Glue the hinges (and tailgear bearing) into the slots in the wing, stab and fin TE. **NOTE:** When gluing in the nylon tailgear bearing, do not just smear glue on the bearing and push it into the slot, as most of the glue will be wiped off as it is being pushed in. You must also work some glue into the slot. A good way of doing this is to scoop up some epoxy with a plastic soda straw, then pinch the end of the straw, insert it into the slot, and squeeze the straw to force glue into the slot. We recommend 30-minute epoxy for this process. After pushing in the bearing, **wipe away all excess glue with a tissue dampened with rubbing alcohol.**

Build the Cockpit Floor (Optional)

- 1. Cut out the Cockpit Floor Pattern on the fuselage plan and paste it to a scrap piece of 1/8" light plywood (not included). Cut along the outline to make the cockpit floor. If you are going to install seats and a pilot, drill 1/16" holes at the marks provided.
- 2. Test fit the cockpit floor into the fuselage and sand the edges if needed to achieve a nice fit. Paint or cover the cockpit floor to make it look nice.
- 3. Cut four 1/2" x 3/4" x 1" hardwood mounting blocks (not included) and glue them to the fuselage sides as shown in the photo. They should be positioned along the bottom edge of the upper doubler to allow clearance for the servos. Mark on the fuse sides, the location of the blocks so you know where to drill the holes in the next step.



- 4. Lay the cockpit floor in position and drill 1/16" holes approximately 1/4" away from the fuse side where each mounting block is located. Remove the floor and enlarge the holes in the floor **only to 3/32"**. Use #2 screws to install the floor.

Painting the Pilot (Optional)



- ❑ 1. We used a 1/5 scale Williams Brothers #185 Sportsman Pilot. Assemble your pilot and then glue it to a 1/2" thick balsa block so he will be about the right height. Shape the block to match the body contour of the pilot. Paint the pilot and balsa block as desired and mount him to the cockpit floor using two #4 or #6 wood screws (not included). **NOTE:** The pilot always flies the full size J-3 Cub from the rear seat when he is flying solo.

Building the Seats (Optional)

- ❑ 1. Shape the seat backs from 1/4" hard balsa. The front seat is often rounded and the aft seat usually has straight edges.
- ❑ 2. Glue a piece of 1/8" or 1/4" foam rubber to one surface of each seat. Rubber cement works well for this.
- ❑ 3. Cover the seat backs with a thin soft black vinyl (available at most fabric stores). Pull the vinyl tight and glue it in place with CA.



- ❑ 4. Cut several straight pins to approximately 3/16" long. Press the pins through the front of each seat to simulate the upholstery buttons. Paint the heads of the pins to match the vinyl.



- ❑ 5. Position the seat backs over the 1/16" holes you drilled earlier in the cockpit floor. Screw the seat backs to the cockpit floor using #2 or #4 sheet metal screws (not included).

Build the Landing Gear Suspension (Optional)

The landing gear suspension displayed on the box is for appearance only. It does not function.

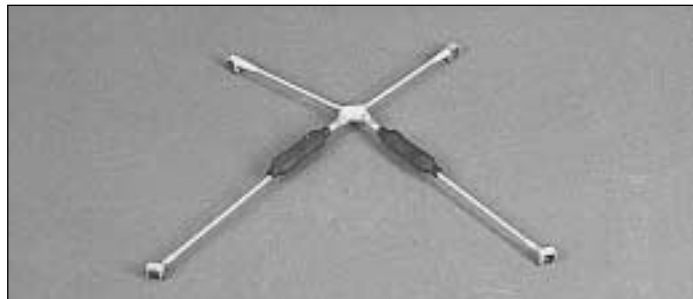

- ❑ 1. You can get as detailed as you like on the suspension, but we have found that a simple suspension is much easier to assemble.

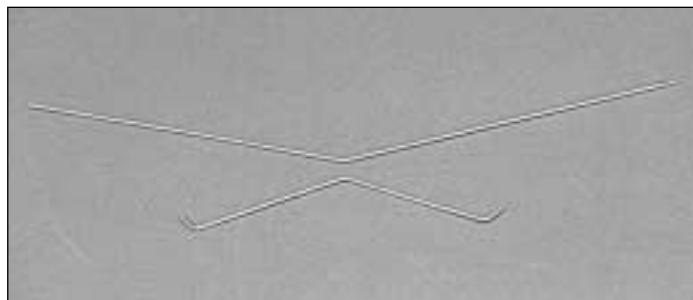

- ❑ 2. Bend two pieces of 3/32" music wire (or .095" pushrod wire) to match the full size template on the fuselage plans.

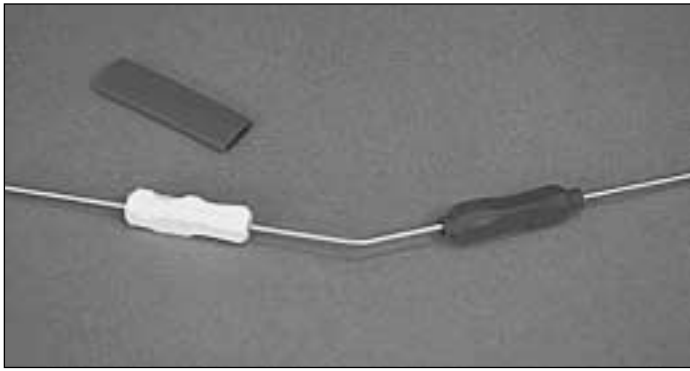

❑ 4. Make the "Shocks" by drilling a $\frac{3}{32}$ " hole through the middle of a $\frac{5}{16}$ " x $\frac{5}{16}$ " x $1\text{-}1/4$ " long piece of balsa. Use your hobby knife to carve a few irregular slices out of the square pieces. Slide them onto the lower wire and glue them in place about 1" below the bend in the wire. Cover them with a piece of $\frac{3}{8}$ " diameter, black heat shrink tubing and shrink it tightly around the shocks.

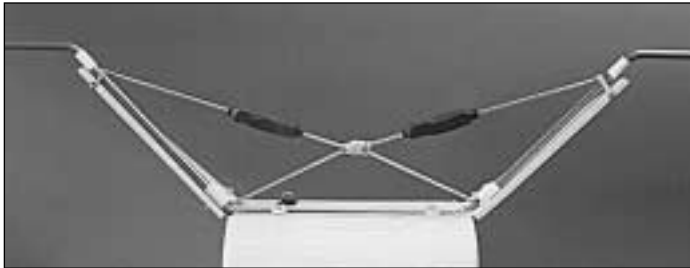

❑ 5. Use small rubber bands or small pieces of heat shrink tubing to attach the suspension to the landing gear struts. Use another piece of rubber band to hold the lower wire to the upper wire. A drop of CA will hold it in place. We do not recommend permanently attaching the suspension, as it will get caught in tall grass and flip the plane over on take-offs and landings.

Building the Dummy Engines

NOTE: Notice that there is a right and a left dummy engine. If you installed your engine inverted and the muffler is not in the way, you can install both a right and a left dummy engine.

❑ 1. Cut the molded ABS **Dummy Cylinder** (CUB4F23) out along the molded in trim line. Sand the edge smooth. Paint the cylinders flat black and the valve covers aluminum. We used Testor's plastic model paint, which worked well.



❑ 2. Cut the **Engine Shroud** out along the trim line and sand its edges smooth. Test fit the shroud in place on the cylinders as shown in the next photo. Trim and sand as required for a good fit. Paint both the inside and the outside of the shroud flat black.



❑ 3. Glue the shroud to the dummy cylinders with CA. It is a good idea to make scratch marks or poke holes on the dummy cylinder in the area where the shroud will be attached. This will help the glue adhere.



❑ 4. Using a hobby knife and sandpaper remove the paint from the cowl in the area that the dummy engine mounts. Glue the dummy engine to the cowl in the approximate location shown in the photo and on the plans. A simple "exhaust system" can be added using $\frac{3}{16}$ " diameter rubber vacuum tubing and scrap wire (see photo on box cover). Drill holes in each of the cylinders and in the cowl to insert the wires in. The decal sheet includes "Continental" decals which can be added to each valve cover.

Other Scale Details



❑ 1. You can make a simple **step** out of scrap pushrod wire. Drill **5/64"** holes just behind the left LG fairing and glue it in place as shown in the photo.

❑ 2. A scale fuel gauge can be made out of two pieces of dowel and a short piece of pushrod wire (see photo below). Glue a 1/8" long piece of 1/2" diameter hardwood dowel between two 1/8" long pieces of 3/8" diameter dowel. Cut or file some "finger grips" in the 1/2" dowel. Bend a 1" long piece of scrap pushrod wire 90 degrees approximately 1/8" from one end. Drill a 5/64" hole in the center of the 3/8" dowel and glue the bent pushrod wire in place.



❑ 3. The windshield bracing can be cut from 1/8" diameter hardwood dowels (not included). Glue them in place.

❑ 4. Install the instrument panel decal. You can also cover the lightening hole in the top tank floor with black sandpaper or other material if desired.



❑ 5. A scale prop can be made using a regular Top Flite 10 x 6 Power Point Prop. Round off the ends using sandpaper and use a little bit of dark stain to give the prop a darker color and to bring out the grain of the wood. Paint the tips black, the leading edges and tips gold and then apply spots of silver with a tooth pick to resemble the screws as shown in the photo. The prop decals are included on the decal sheet. **NOTE:** This prop should only be used for "show," and not for flying.

❑ 6. A simple exhaust pipe can be made out of aluminum tubing. (See box lid.) We used a 1-1/2" long piece of 1/4" diameter tube with one end sanded to a slant and a 1" long piece of 3/8" diameter tube. Wrap tape around the unslanted end of the 1/4" tube until it fits snugly in the 3/8" tube. Position the tubes as shown in the photo and glue with thin CA. Drill a 3/8" hole in the bottom of the cowl and glue the assembly in place with epoxy.

Install the Windshield

❑ 1. Lightly sand a strip approximately **1/8"** wide along the inside of the windshield (around the perimeter). **NOTE:** To avoid sanding more than you want, it is helpful to first apply strips of masking tape on the inside of the windshield, 1/8" in from the edges.

❑ 2. Hold the windshield in place on the fuselage and mark on the fuse around the outside edge of the windshield with a fine tip permanent marker. Remove the windshield and use a T-Pin to poke holes in the covering every **1/8"** or so where the windshield will be glued. Paint the top of the instrument panel flat black if desired. Use a paper towel soaked with alcohol to remove the marker from the fuselage.

❑ 3. Very carefully glue the windshield in place. Use tape to hold it in place while the glue cures. There are several glues available (RC-56, etc.) that work well for installing canopies. Medium CA also works well, but you must take your time and only apply a drop or two of CA at a time or the glue may "fog" the windshield. When using CA, tape the windshield in place and apply the CA to the outside edge. The CA will wick under the windshield slightly and will bond the windshield to the covering material. **NOTE:** Use care to avoid getting CA on the outside exposed surface of the windshield.

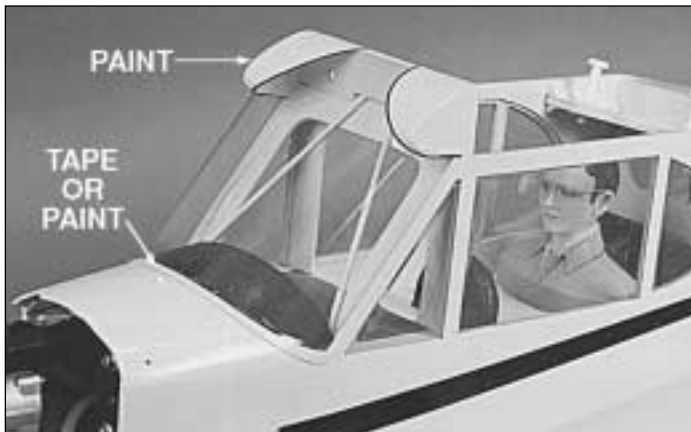

❑ 4. To hide the windshield glue joint, you may use 1/4" Cub Yellow striping tape or paint a border around the windshield. Also, paint the "Wing LE's" (molded into the canopy) to match the wing covering.

Install Side Windows

NOTE: Install the side windows after the model has been covered.

❑ 1. Using a hobby knife or scissors, cut the clear plastic **side windows** from the sheet by cutting along the molded-in trim lines. Notice that the front side windows are cut separately from the sheet.

❑ 2. Carefully sand the edges of each window panel with #400-grit sandpaper to remove any irregularities caused by trimming, but use care not to scratch the surface of the windows.

❑ 3. Thoroughly clean the covering material around the inside edges of the windows with alcohol, to remove all traces of skin oils.

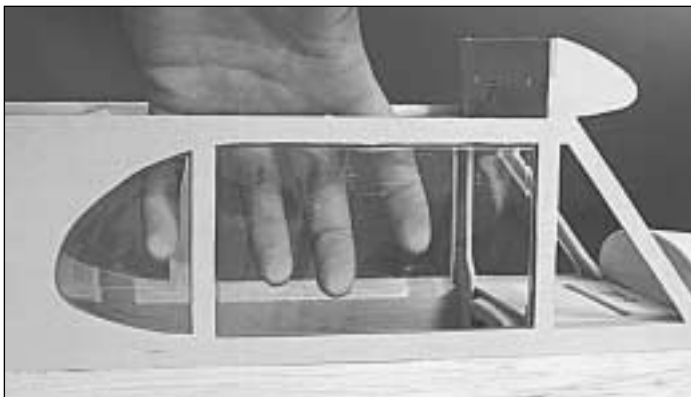

❑ 4. Very carefully apply medium or thick CA (or another glue, RC-56 etc.) to the window flanges. Position the window in place and hold or tape it until the glue is cured.

Balance Your Model

NOTE: This section is VERY important and must not be omitted! A model that is not properly balanced will be unstable and possibly unflyable.

❑ 1. Accurately mark the balance point on the bottom of the wing on both sides of the fuselage. The balance point is shown on the plan (**CG**), and is located approximately **4"** back from the leading edge. This is the balance point at which your model should balance for your first flights. Later, you may wish to shift the balance up to **3/8" forward or back** to change the flying characteristics. Moving the balance forward results in a model that is more resistant to stalls and spins but also may act sluggish and require more speed for takeoff and landing. Moving the balance aft makes the model more agile with a lighter and snappier "feel" and often improves snap roll and knife-edge capabilities. In any case, **do not balance your model outside the recommended range.**

❑ 2. With the wing attached to the fuselage, all parts of the model installed (ready to fly), and an **empty** fuel tank, block up the tail until the bottom edges of the side windows are level.

❑ 3. Lift the model at the CG marks. If the tail drops when you lift, the model is "tail heavy" and you must add weight to the nose to balance. If the nose drops, it is "nose heavy" and you must add weight to the tail to balance. **NOTE:** Nose weight may be easily installed by using an Aluminum (GPMQ4630) or Brass (GPMQ4640) Spinner Nut, or by screwing strips of lead onto the firewall under the engine. Tail weight may be added by using "stick-on" lead weights (GPMQ4485), and later, if the balance proves to be OK, you can open the fuse bottom and glue these in permanently.

Final Hookups and Checks

4-CHANNEL RADIO SETUP (STANDARD MODE 2)

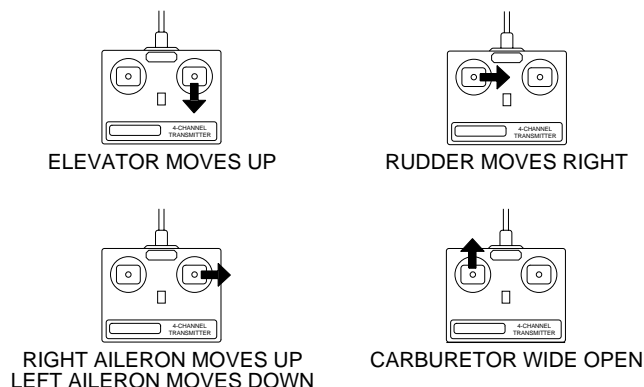

❑ 1. Make sure the control surfaces move in the proper direction as illustrated.

2. Adjust your pushrod hookups as necessary to provide the proper control surface movements as listed on Page 38. ***NOTE:** These control surface “throws” are approximate and provide a good starting point for the first flights with your J-3 Cub. You may wish to change the throws slightly to provide the smoothness or quickness that you prefer.

3. Check for wing twist as follows:

NOTE: Even if you have built your wing on a perfectly flat surface and used utmost care, it is possible that your wing may have a twist due to uneven shrinking of the covering material. You must check for this condition and correct it before the first flight. Wing twist is the most common cause of poor-flying airplanes.

If you do not own a **wing incidence meter**, we recommend that you purchase one from your local hobby dealer or borrow one from another modeler. With the wing mounted to the fuselage, use the incidence meter to check the angle of your wing at the root and at the tips. If the incidence meter reveals a wing twist of more than 1/4 degree, you must grasp the wing at the tip and twist it slightly, while reheating the covering material. Keep checking, twisting and reheating until the wing twist is removed. **NOTE:** If you have corrected a wing twist by this method, you should periodically re-check to make sure the correction has held. In addition, re-check for wing twist with the wing struts installed. Make sure that the struts do not introduce a wing twist.

4. Following is a checklist of some other items you'll want to consider before your first flight with this model:

- Record weight
- Check all screws, use Loctite
- Adjust tailgear for straight roll
- Adjust throttle pushrod linkage
- Take photographs!
- Balance propeller & spinner
- Oil axles
- Place AMA I.D. sticker inside

PREFLIGHT

Charge the Batteries

Follow the battery charging procedures in your radio instruction manual. You should **always** charge your transmitter and receiver batteries the night before you go flying, and at other times as recommended by the radio manufacturer.

Find a Safe Place to Fly

The best place to fly your R/C model is an AMA (Academy of Model Aeronautics) chartered club field. Ask your hobby shop dealer if there is such a club in your area and join. Club fields are set up for R/C flying which makes your outing safer and more enjoyable. The AMA can also tell you the name of a club in your area. We recommend that you join AMA and a local club so you can have a safe place to fly and also have insurance to cover you in case of a flying accident. (The AMA address is listed near the front of this instruction book).

If a club and its flying site are not available, you need to find a large, grassy area at least 6 miles away from any other R/C radio operation like R/C boats and R/C cars and away from houses, buildings and streets. A schoolyard may look inviting but it is too close to people, power lines and possible radio interference.

Ground Check the Model

If you are not thoroughly familiar with the operation of R/C models, ask an experienced modeler to check to see that you have the radio installed correctly and that all the control surfaces do what they are supposed to. The engine operation must also be checked and the engine “broken in” on the ground by running the engine for at least two tanks of fuel. **Follow the engine manufacturer’s recommendations for break-in.** Check to make sure all screws remain tight, that the hinges are secure and that the prop is on tight.

Range Check Your Radio

Wherever you do fly, you need to check the operation of the radio before every time you fly. This means with the transmitter antenna collapsed and the receiver and transmitter on, you should be able to walk at least 100 feet away from the model and still have control. Have someone help you. Have them stand by your model and, while you work the controls, tell you what the various control surfaces are doing.

Repeat this test **with the engine running** at various speeds with an assistant holding the model. If the control surfaces are not acting correctly at all times, **do not fly!** Find and correct the problem first.

Engine Safety Precautions

NOTE: Failure to follow these safety precautions may result in severe injury to yourself and others.

- Keep all engine fuel in a safe place, away from high heat, sparks or flames, as fuel is very flammable. Do not smoke

near the engine or fuel; remember that the engine exhaust gives off a great deal of deadly carbon monoxide. Therefore **do not run the engine in a closed room or garage.**

- Get help from an experienced pilot when learning to operate engines.
- Use safety glasses when starting or running engines.
- Do not run the engine in an area of loose gravel or sand, as the propeller may throw such material in your face or eyes.
- Keep your face and body as well as all spectators away from the plane of rotation of the propeller as you start and run the engine.
- Keep items such as these away from the prop: loose clothing, shirt sleeves, ties, scarfs, long hair or loose objects (pencils, screw drivers) that may fall out of shirt or jacket pockets into the prop.
- Use a “chicken stick” device or electric starter, following the instructions supplied with the starter or stick. Make certain the glow plug clip or connector is secure so that it will not pop off or otherwise get into the running propeller.
- Make all engine adjustments from **behind** the rotating prop.
- The engine gets hot! Do not touch it during or after operation. Make sure fuel lines are in good condition so fuel is not leaked onto a hot engine, causing a fire.
- To stop the engine, cut off the fuel supply by closing off the fuel line or follow the engine manufacturer’s recommendations. Do not use hands, fingers or any body part to try to stop the engine. Do not throw anything into the prop of a running engine.

AMA SAFETY CODE (EXCERPT)

Read and abide by the following Academy of Model Aeronautics Official Safety Code:

General

1. I will not fly my model aircraft in competition or in the presence of spectators until it has been proven to be airworthy by having been previously successfully flight tested.
2. I will not fly my model aircraft higher than approximately 400 feet within 3 miles of an airport without notifying the airport operator. I will give right of way to, and avoid flying in the proximity of full scale aircraft. Where necessary an observer shall be utilized to supervise flying to avoid having models fly in the proximity of full scale aircraft.

3. Where established, I will abide by the safety rules for the flying site I use, and I will not willfully and deliberately fly my models in a careless, reckless and/or dangerous manner.

(Read the complete Code for additional requirements)

Radio Control

1. I will have completed a successful radio equipment ground range check before the first flight of a new or repaired model.
2. I will not fly my model aircraft in the presence of spectators until I become a qualified flier, unless assisted by an experienced helper.
3. I will perform my initial turn after takeoff away from the pit or spectator areas, unless beyond my control.

FLYING

The **J-3 CUB** is a great-looking scale airplane **and** a great-flying sport airplane that, true to its full-size counterpart, is surprisingly aerobatic. It does **not** have the self-recovery characteristics of a primary trainer. Therefore, you must either have mastered the basics of R/C flying or seek the assistance of a competent R/C pilot to help you with your first flights.

NOTE: We encourage you to fly this airplane only with the cowl attached, because the cowl streamlines the airframe and results in better flying characteristics.

Takeoff

TAKEOFF: Do a low speed taxi test before your first takeoff. If the plane does not track straight when the rudder is in neutral, check the alignment of the main gear and the tailgear. If necessary adjust the wires with pliers. **Don’t adjust the ground steering with the rudder trim or the rudder trim will be off in flight!** Although the **J-3 CUB** has good low speed characteristics, you should always build up as much speed as your runway will permit before lifting off, as this will give you a safety margin in case of a “flame-out”. The tail will come up off the ground very quickly, but allow the plane to remain on the ground until it gains plenty of airspeed. Climb out gradually and let it gain some airspeed before hunting for the clouds. For safety, always remember to make your first turn away from the pit area.

Flying

We recommend that you take it easy with your **J-3 CUB** for the first several flights and gradually “get acquainted” with its flying characteristics as your engine gets fully broken-in. Work on trimming the airplane for straight and level flight with the transmitter trims at neutral, adjusting the nylon clevises after each flight, as necessary. Also, take note of the responsiveness of the elevator, ailerons and rudder, and adjust their throws to your preference. Add and practice one maneuver at a time, learning how it behaves in each one. You may notice some “sluggishness” in the way your J-3 Cub handles at low speeds with the regular wing. This is normal and should be taken into consideration when flying “low and slow”. Your Cub is capable of performing an impressive array of maneuvers. However, you can expect some roll coupling with rudder when attempting knife edge maneuvers. **Full-throttle snap rolls are not recommended**, due to the extremely high stresses they place on the structure.

Landing

Because the J-3 Cub has a light wing loading and a high lift airfoil, it really floats when the throttle is reduced. You will usually find it hard to get the plane down on the ground without pulling the throttle to a very slow idle. A little practice is all it takes to make 1 or 3-point landings look easy.

CAUTION

(THIS APPLIES TO ALL R/C AIRPLANES)

If, while flying, you notice any unusual sounds, such as a low-pitched “buzz”, this may be an indication of control surface “flutter”. Because flutter can quickly destroy components of your airplane, any time you detect flutter you must **immediately** cut the throttle and land the airplane! Check all servo grommets for deterioration (this will indicate which surface fluttered), and make sure all pushrod linkages are slop-free. If it fluttered once, it will probably flutter again under similar circumstances unless you can eliminate the slop or flexing in the linkages. Here are some things which can result in flutter: excessive hinge gap; not mounting control horns solidly; sloppy fit of clevis pin in horn; elasticity present in flexible plastic pushrods; side-play of pushrod in guide tube caused by tight bends; sloppy fit of L-bend in servo arm; insufficient glue used when gluing in the elevator joiner wire or aileron torque rod; excessive flexing of aileron, caused by using too soft balsa aileron; excessive “play” or “backlash” in servo gears; and insecure servo mounting.

Have a ball!

But always stay in control and fly in a safe manner.

GOOD LUCK AND GREAT FLYING!

Two-View Diagram

*Use this drawing for planning
your trim scheme.*

