

Chipmunk 400

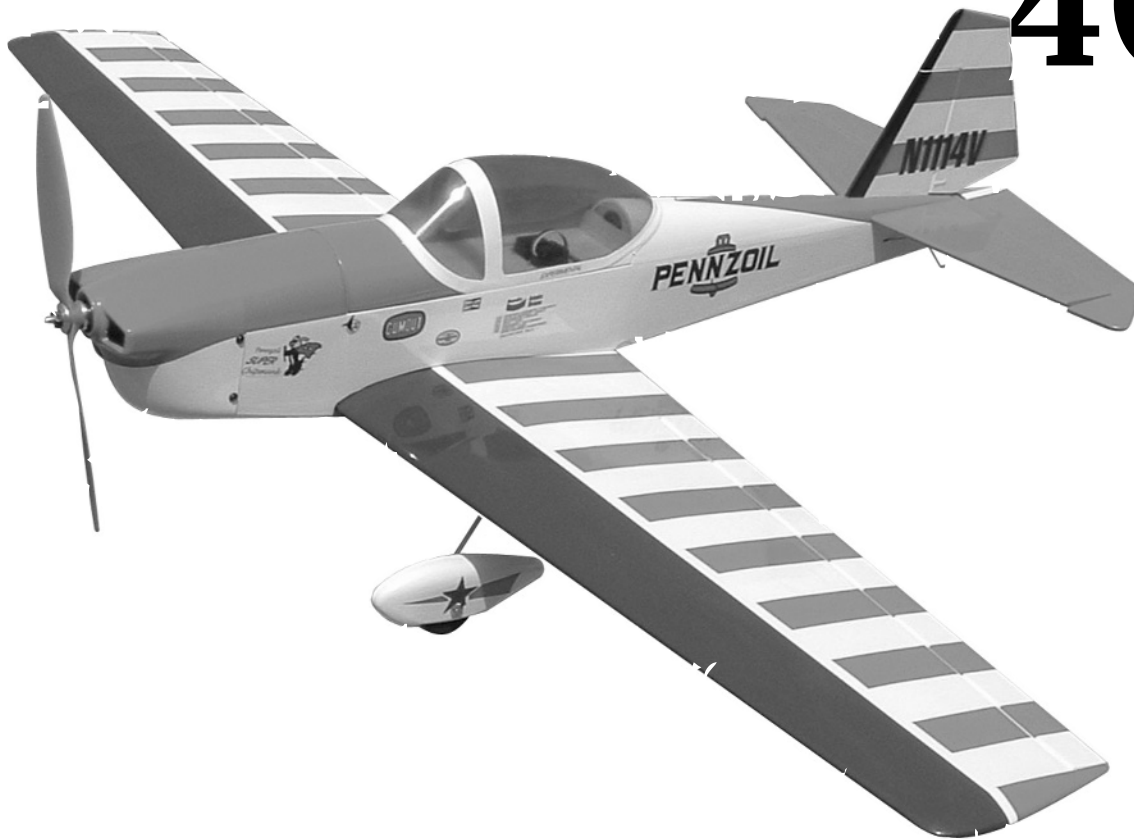

WARNING

A radio-controlled model is not a toy and is not intended for persons under 16 years old. Keep this kit out of the reach of younger children, as it contains parts that could be dangerous. A radio-controlled model is capable of causing serious bodily injury and property damage. It is the buyer's responsibility to assemble this aircraft correctly and to properly install the motor, radio, and all other equipment. Test and fly the finished model only in the presence and with the assistance of another experienced R/C flyer. The model must always be operated and flown using great care and common sense, as well as in accordance with the Safety Code of the Academy of Model Aeronautics (5151 Memorial Drive, Muncie, IN 47302, 1-800-435-9262). We suggest you join the AMA and become properly insured prior to flying this model. Also, consult with the AMA or your local hobby dealer to find an experienced instructor in your area. Per the Federal Communications Commission, you are required to use only those radio frequencies specified "for Model Aircraft."

LIMITED WARRANTY

Carl Goldberg Products, Ltd. has inspected and certified the components of this aircraft. The company urges the buyer to perform his own inspection, prior to assembly, and to immediately request a replacement of any parts he believes to be defective for their intended use. The company warrants replacement of any such components, provided the buyer requests such replacement within a period of 10 days from the date of purchase and provided the defective part is returned, if so requested by the company.

No other warranty, expressed or implied, is made by the company with respect to this kit. The buyer acknowledges and understands that it is his responsibility to carefully assemble the finished flying model airplane and to fly it safely. The buyer hereby assumes full responsibility for the risk and all liability for personal or property damage or injury arising out of the buyer's use of the components of this kit.

CARL GOLDBERG PRODUCTS, LTD.

USING THIS INSTRUCTION MANUAL

Before you begin assembling your **Chipmunk 400 ARF**, take some time to read through this entire instruction book. It is designed to take you step-by-step through the process and to give you added information on motor and radio selection and set-up, balancing your aircraft, and flying your model. The time you spend will speed the assembly process and help you avoid problems.

PREPARING FOR ASSEMBLY

You will need a work area of approximately 24 x 48" which has been covered to protect it from adhesive, as well as cuts and other damage. Many people cover their work area with a sheet of dry wall (sheet rock) and/or waxed paper to prevent CA Glue and Epoxy from ruining the work surface.

CONSTRUCTION TIPS

IMPORTANT: ALWAYS READ A FEW STEPS AHEAD. This will alert you to coming instructions and will help you plan accordingly.

Using the Parts Identification section, familiarize yourself with the various items included in your kit box.

Do not hesitate to ask questions. Your local hobby dealer and area flyers will most likely be happy to help, as they want you to have a successful flying experience.

ADHESIVES & GLUING TECHNIQUES

CA adhesives are specially formulated to firmly glue the plywood, hardwood, and balsa used in your model and to withstand the vibration and stresses of high performance flight. However, there are times, such as when you are installing the stabilizer and fin on the fuselage and want more set-up time for careful alignment and positioning, then you should use epoxy. Occasionally, you also will want to use thin CA, which "wicks" into the surrounding areas. Aliphatic resin glue or similar water-based glues can also be used, but they will add to the assembly time because they dry so much more slowly than CA glue. Remember, when ever using any CA, you must be careful to read instructions thoroughly, as you will have only seconds for positioning of parts. Be sure to trial fit parts together before gluing. Also, never use watery THIN type CA glue for gluing plywood and hardwood parts. Thin CA's do not adequately bond these areas.

CAUTION

Some people may experience an allergic reaction when exposed to fumes from CA glue or epoxy. As with paints, thinners, and solvents, it is always important to use glues only where there is adequate ventilation to carry fumes away. A fan is recommended. Also, special care must be taken when using CA, as it will bond skin as well as other surfaces. Before using any CA, carefully read all label precautions. When using CA, protective eye-wear and care in keeping the glue away from the face is highly recommended. If CA does happen to get into the eye, hold lid open and flush with water only. Seek immediate medical attention.

COVERING

The Chipmunk 400 ARF is covered in a polyester film chosen for its beauty, toughness, and ease of application and repair. It is not uncommon for ARF's to develop a few wrinkles in transit. If this is true of your model, the situation is easily corrected. Before you begin putting the pieces together, run around the edge of the seams first then over the surface of each section with an iron (either specially designed for airplane use or the more cumbersome household iron). Apply the heat (set at about 350° F), following along with a soft cloth and pressing down on the covering as you go around. This will more firmly set the covering adhesive into the wood and keep your aircraft covering tight and smooth in the future. Once you have ironed the seams stay away from them with the heat or the covering will slide when you try to shrink the middle. If this happens the wrinkles will not come out of the covering.

One of the great advantages of polyester film is that it can be applied over itself without causing gas bubbles. This allows you to repair your aircraft, as well as to customize it in a number of ways. If, due to a flight mishap, you get a hole or similar covering damage, simply trim away the ragged edges and then apply a patch, following the directions that come with your covering , which is available at your hobby dealer.

The Chipmunk 400 covering can be closely matched using

Oracover Flame Red

Oracover White

Oracover Midnight Blue

ITEMS NEEDED TO COMPLETE THIS AIRCRAFT

- 1 4 CHANNEL RADIO WITH 4 MICRO SERVO. (WE USED 4 CHANNEL **FUTABA** RADIO WITH S3108 SERVO AND **GREAT PLANES** ELECTRIFLY RECEIVER W/O SPEED CONTROL)
- 1 6" SERVO "Y" HARNESS
- 2 6" SERVO EXTENSIONS
- 1 ELECTRONIC SPEED CONTROL (WE USED A **CASTLE CREATIONS** PHOENIX 25 BRUSHLESS SPEED CONTROL)
- 1 3 CELL LI-PO BATTERY (**GREAT PLANES** ELECTRIFLY 1500)
- 1 **ULTRAFly** BRUSHLESS MOTOR A/30/29 WITH 3.89 GEAR RATIO
- 1 **GREAT PLANES** ELECTRIFLY PROP ADAPTER 3MM APC LONG
- 1 **APC** PROPELLER 9 X4.7 SLO FLYER
- 1 CA ACCELERATOR
- 1 1 OZ. BOTTLE CA MEDIUM GLUE
- 1 1/2 OZ. BOTTLE CA THIN GLUE
- 1 5 MINUET EPOXY
- 1 1/4" FOAM RUBBER
- 1 #2 X 1/4" SHEET METAL SCREW FOR MOTOR(MIGHT BE REQUIRED FOR SOME MOTOR INSTALLATIONS)

TOOLS AND SUPPLIES FOR ASSEMBLY.

- MODELING OR UTILITY KNIFE
- WORK SURFACE (24" X48")
- SMALL STANDARD & PHILLIPS SCREW-DRIVERS
- MASKING TAPE
- NEEDLE NOSE PLIERS
- 24" RULER
- FLEXIBLE STRAIGHT-EDGE
- 30-60-90° x 6" TRIANGLE
- SOFT PENCIL
- A FEW STRAIGHT OR "T" PINS
- WIRE CUTTER (DYKES)
- OPTIONAL HEAT GUN/COVERING IRON
- ACID BRUSH
- 5 FT. LENGTH OF STRING

Caution:

Before starting, carefully go over all high stress areas (Wing bolt mounting blocks, Firewall,etc.) with an epoxy or wood glue to confirm all areas are well glued.

Wing

JOINING THE WING



1. Collect the following items:
 - (1) Right wing
 - (1) Left wing
 - (1) Wing joiners
 - (2) 5mm x 17 dowel
 - A book or block of wood

NOTE: If the covering on your wing has loosened in transit, refer to the covering section of the INTRODUCTION before continuing.

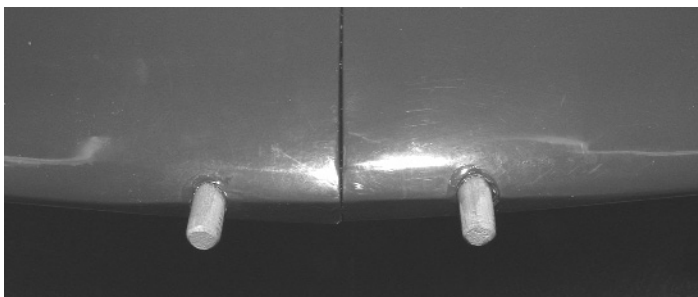

2. Insert the wing joiner with the angle cut facing up, into the joiner pockets in both wing halves. The joiners should fit easily in the pockets and the wing halves should meet in the middle, with the wing dihedral forming a broad "V".
 - Trial fit the wing dowel in the hole, as shown above. When satisfied with the fit of the dowel and the joiners, remove them from the wing pockets.
3. Working on a protected surface, and with a paper towel handy for cleaning fingers, **THOROUGHLY** mix 1-2 large (soup) spoons each from bottle A and bottle B of Epoxy. (Use equal amount of each part and mix with a stick in a plastic or paper cup, or on a sheet of waxed paper.)

- Spread epoxy on the joiner
 - Put additional epoxy in the joiner pockets and in the dowel hole and spread a thin layer of epoxy along one side of the entire center joint area. **Immediately proceed to the next step.**
4. Working rapidly, so that the epoxy does not set before you are finished, slide the wing joiner into one wing pocket.
 - Slide the dowels into the dowel holes. Then slide the wing halves together until they are touching.

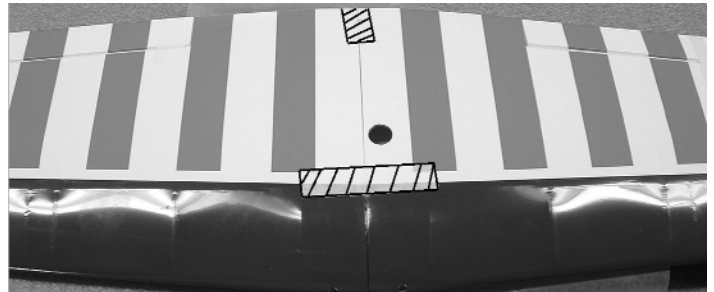

5. With masking tape, tape the wing halves together at the trailing edge and close to the leading edge, as shown. This will help keep the wing from twisting.
 - Place additional tape at several locations across the center seam of the wing, so that the halves stay firmly together while the epoxy sets.

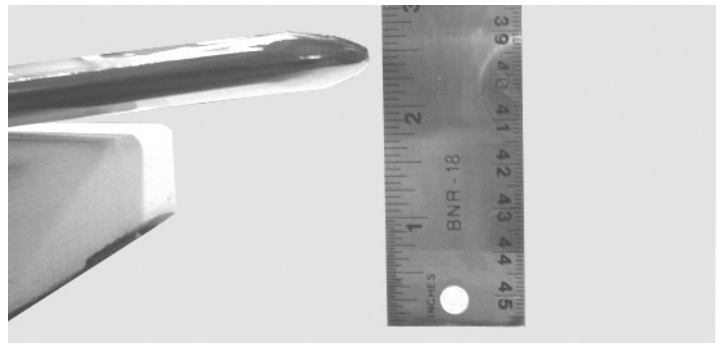
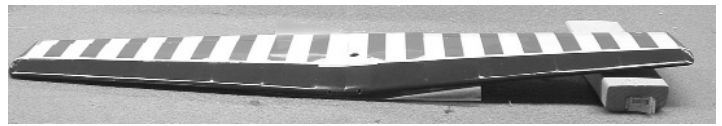

NOTE: When one wing half is flat on the table, the wing dihedral will force the other side of the wing up about 2-1/2" off the table. Place a book or a block of wood under the high side to support the wing and keep the halves in proper position. Caution: Do not distort the wing by blocking it too high or too low, and do not touch the assembly until the epoxy dries.

Installing Ailerons

1. Collect the following parts:
 - (1) Wing
 - (2) Ailerons (Left & Right)
 - (6) Mini CA hinges

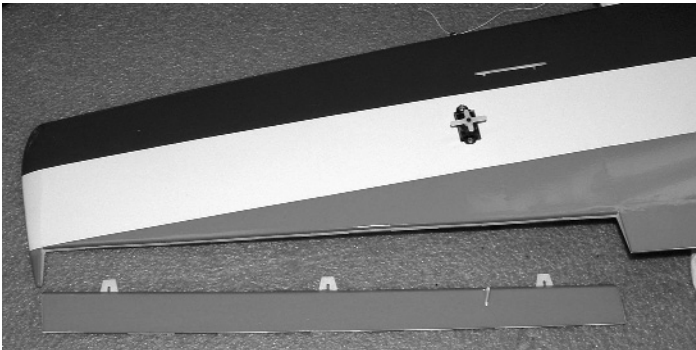

1. Locate the pre-cut aileron hinge slots in both sides of the wing. Using a hobby knife (#11 blade), slide the blade into each slot to make sure it is cleanly cut.
 - Repeat this process with the ailerons, making sure all hinge slots are clean.

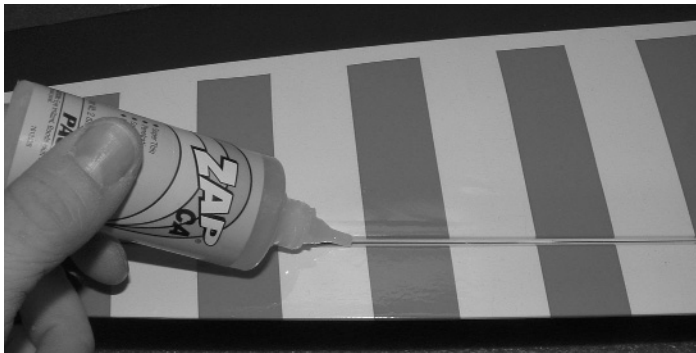

2. Find the control horn slot near one end of the aileron.
 - Align the slot in the aileron with the servo hole in the wing.
 - Insert the mini CA hinges half way into the wing and the ailerons. (Use a pin inserted into the middle of the hinge to help keep the hinge in the middle.)
 - Make sure that the aileron is tight against the wing and even with the wing tip.
 - Using thin CA glue, place one drop on all hinges top and bottom.

Aileron Servo Extensions

1. Gather the following items:
 - (2) 6" Extension wires
 - (1) Wing
 - (2) Servos
 - (1) Electrical tape

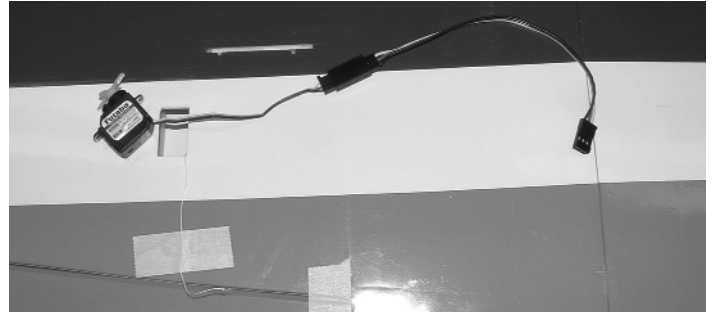

2. Plug one 6" extension wire into one servo.

IMPORTANT! To ensure that any connections located inside the wing will not come loose, either when the wires are pulled, or during flying, always tape them securely together with electrical tape.

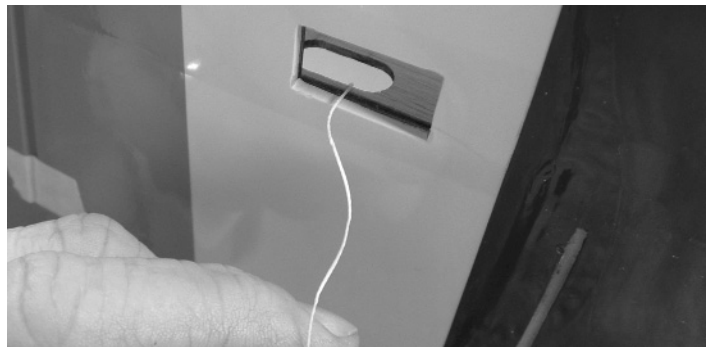

3. Tie the wheel collar to the end of the string.
 - Insert the wheel collar through the servo opening in the wing.
 - Allow the wheel collar to fall through the wing till it can be pulled out through the hole in the center of the wing.

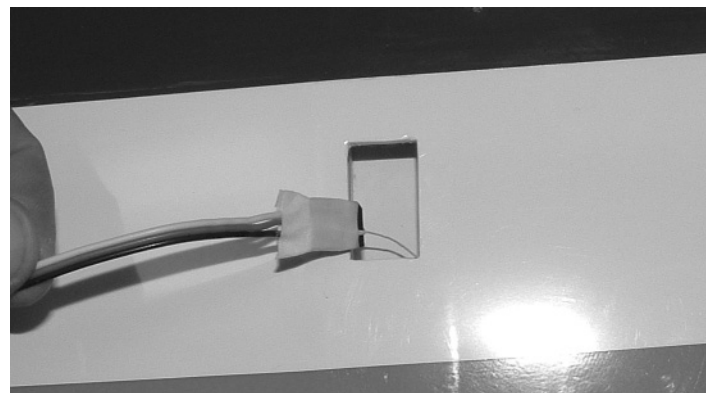

4. Tie or tape the other end of the string to the servo extension.

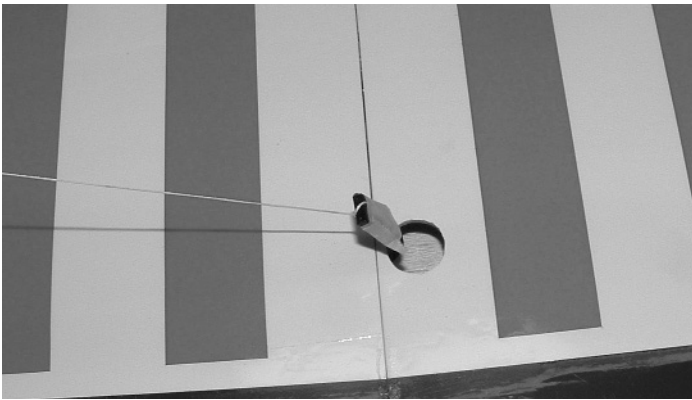

- Push the extension in the servo hole, **SLOWLY** pull until the end of the 6" extension comes out of the hole in the center of the wing.
 - Tape the extension securely to the wing, so that it will not slide back in while you are working.
 - Mount the aileron servo using the hardware provided by the radio manufacture.
5. Repeat steps 2 thru 4 for the other aileron servo.

Aileron Control Horns

1. Collect the following parts:
- (1) Wing
 - (2) Control Horns
 - (2) EZ connectors with screws and nylon nuts.
 - (2) Pushrod Wires



2. Remove the covering on the aileron where the control horn sits.
- Using CA glue, attach the control horn to the aileron.

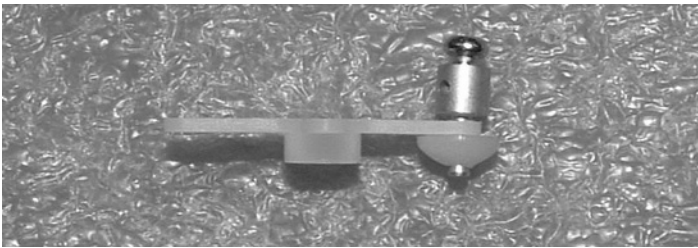

4. Find the small aileron pushrod wire, and place a "z" in one end.
- Connect the pushrod connector to the servo arm.
 - Put the "Z" bend in to the top hole of the control horn.
 - Slide the pushrod wire through the connector on the servo arm and mount the arm on to the servo.
 - Tighten the set screw onto the pushrod.
5. Repeat for the other aileron pushrod.

Fuselage Hatch

1. Collect the following parts:
- (1) Fuselage

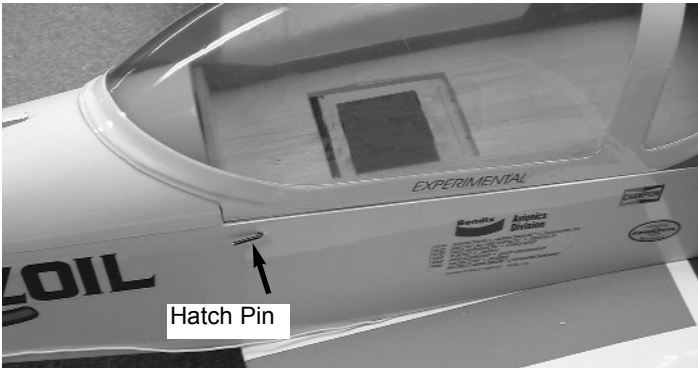

2. Pull Out on the hatch pin.
- Lift up on the rear of the canopy.

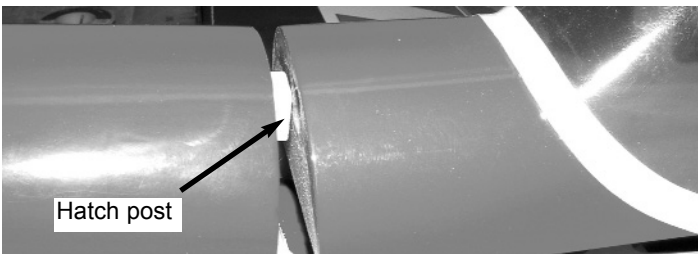

3. Remove the hatch off the front hatch post.

Stabilizer

1. Collect the following parts:
 - (1) Fuselage
 - (1) Stabilizer & Elevator
 - (1) wing
 - (1) 4-40 x 1/2" Socket Head Bolt
 - (1) Wooden Washer covered in red

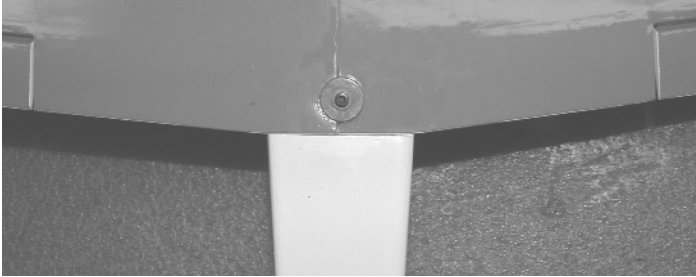

2. Locate the hole in the center of the wing for the wing bolt. Remove the covering over the hole.
 - Mount the wing to the fuselage using the bolt and wooden washer.
 - Make an outline of where the wooden washer rest on the wing.
 - Remove the covering on the wing where the wooden washer will rest.
 - Glue the wooden washer to the wing.

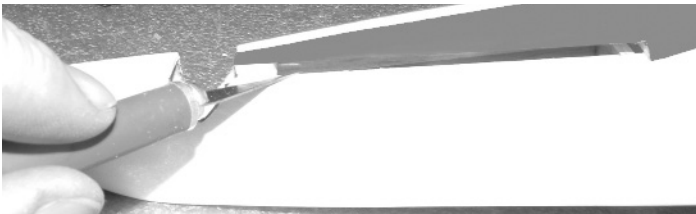

2. Remove the balsa wood plug at the rear of the fuselage where the stabilizer mounts.

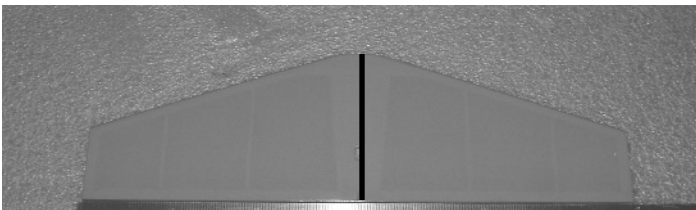

3. Find the center of the stabilizer, by measuring the length of the trailing edge where the elevator hinge line is located.
 - Stand the stabilizer up on its edge and using a right triangle draw a center line up from the trailing edge to the leading edge.
 - Find the center of the fuselage in front of where the stabilizer sits.
 - Place the stabilizer on the fuselage using the marks you just made.

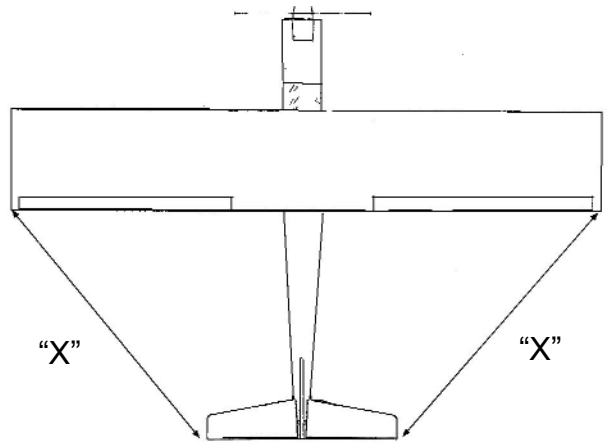

4. Measure from the end of the wing to the tip of the stab. This measurement should be the same for both sides.
 - Mark the stabilizer where it rest on the fuselage
 - Remove the covering where the stab will be glued to the fuselage.

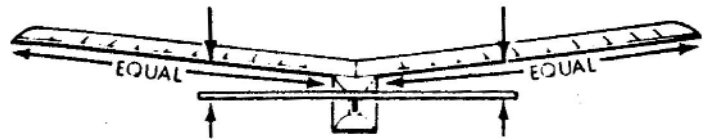

- Look down the length of the fuselage and check that the stabilizer is parallel to the wing. If it is not then shim the low side till they are parallel.
- When satisfied then glue the stabilizer in place using 5 minuet epoxy. Make sure the stabilizer remains both perpendicular and parallel to the wing and fuselage while the epoxy dries.

Elevator Installation

1. Collect the following parts:
 - (1) Fuselage With Stabilizer
 - (2) Elevator
 - (4) Mini CA Hinges
 - (1) Nylon Control Horn
 - (1) Long Pushrod Wire

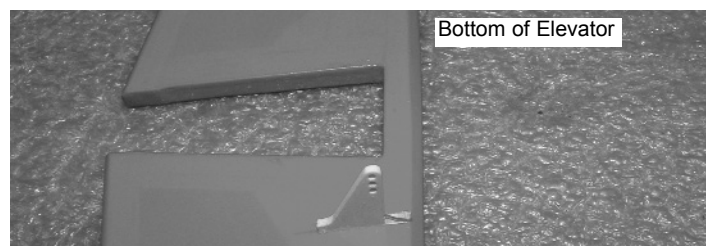

2. Locate the slot in one side of the elevators near the center.
 - Remove the covering over the slot.

- Glue the Nylon control horn into the slot making sure that the elevator is placed on the work bench as shown in the previous photo.



3. Insert the mini hinges into the slots in the elevator.
- Take the long wire pushrod and insert the "Z" bend end into the outer hole of the control horn.
- Insert the wire into the hole in the side of the fuselage.
- Push the elevator forward and insert the hinges into the stabilizer. (use pins to keep the hinges centered)
- Glue the hinges in place same as you did the aileron.

Fin & Rudder Installation

1. Collect the following parts:
 - (1) Fuselage With Stabilizer
 - (2) Fin & Rudder
 - (2) Mini CA Hinges
 - (1) Nylon Control Horn
 - (1) Long Pushrod Wire

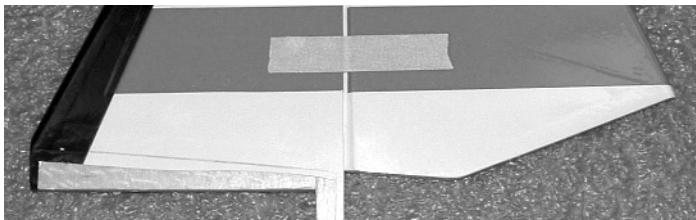

3. Insert the fin into the fuselage slot.
- Mark where the fuselage meets the fin.
- Remove the fin from the fuselage.
- Carefully cut the covering off the fin where the fin will be glued to the fuselage.

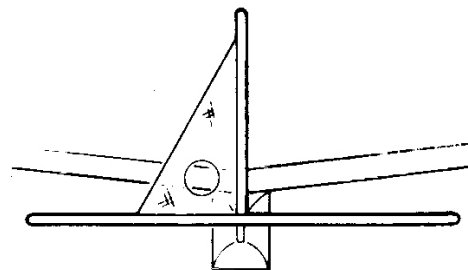

- Remove the rudder from the fin and glue the fin to the fuselage making sure to keep the fin perpendicular to the stabilizer.

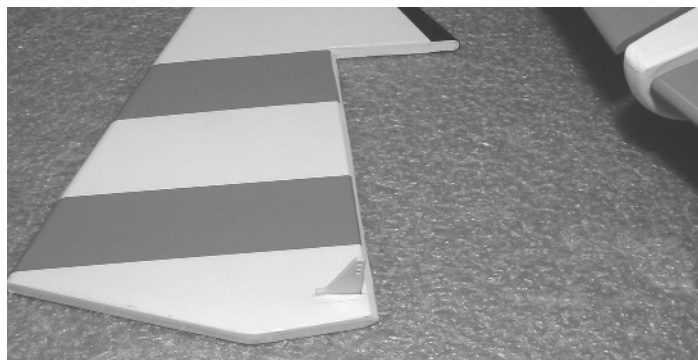

2. Locate the slot in the rudder near the bottom.
- Remove the covering over the slot.
- Glue the Nylon control horn into the slot making sure that the rudder is placed on the work bench as shown above.

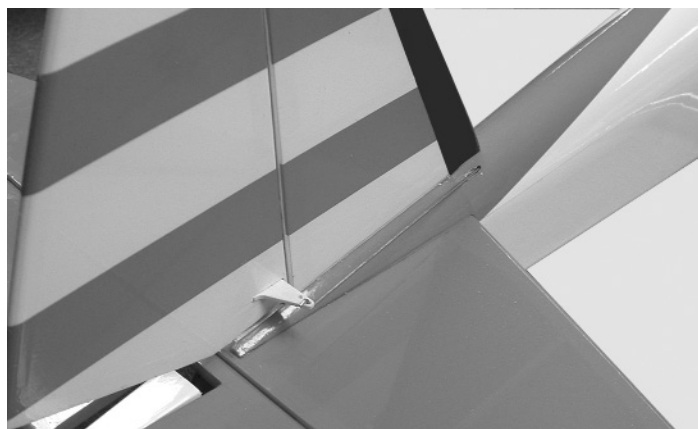

3. Insert the mini hinges into the slots in the rudder.
- Take the long wire pushrod and insert the "Z" bend end into the outer of the control horn.
- Insert the wire into the hole in the top of the fuselage next to the fin.
- Push the rudder forward and insert the hinges into the fin. (use pins to keep the hinges centered)
- Glue the hinges in place.

Landing Gear

1. Collect the following parts:

- (1) wing
- (2) Main Landing Gear Wire
- (4) 2mm x 6 Sheet Metal Screw

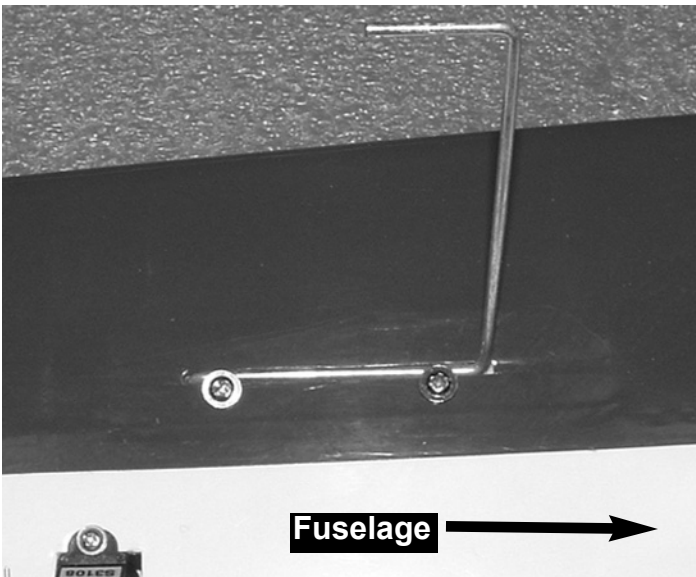

2. Remove any covering over the landing gear slot.
 - Insert the short end of the main landing gear wire into the hole.
 - Locate the two holes next to the landing gear slot.
 - Screw the landing gear into place using two 2mm x 6 Sheet Metal Screws.

Wheel Pants

1. Collect the following parts:

- (1) wing
- (2) Wheel Pants
- (2) Wheel Collars with set screws
- (4) 2mm x 3mm Sheet Metal Screw
- (2) Landing gear strap
- (2) Wheels

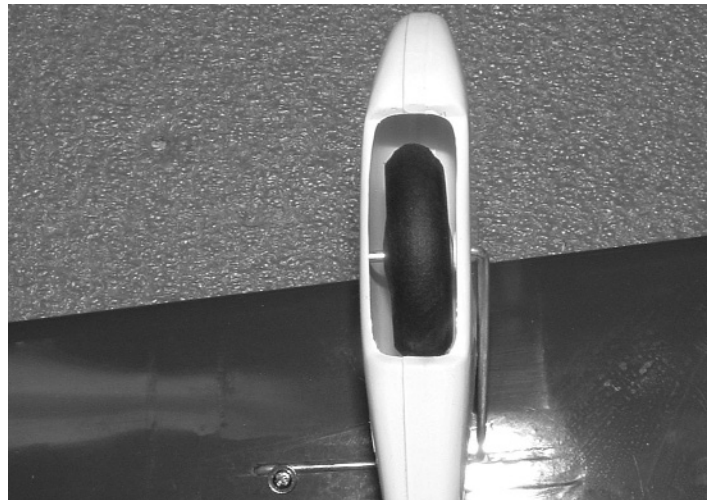
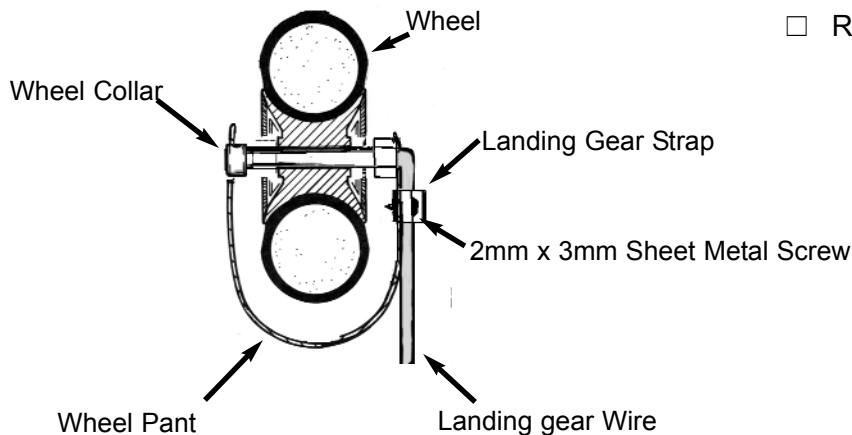

2. Place the wire through the back side of the wheel pants.
 - Insert the wheel into the wheel pant.
 - Push the landing gear wire through the wheel and out the other side of the wheel pant.
 - Insert the wheel collar on the end of the landing gear wire.
 - While **slightly** squeezing the wheel pant tighten the wheel collar onto the landing gear wire.

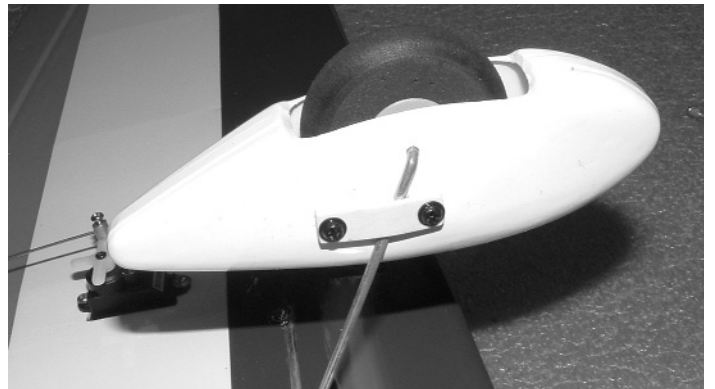

3. Place the landing gear strap onto the landing gear wire so that the slot in the strap fits over the wire.
 - Screw the strap to the wheel pant using the 2mm x 3 sheet metal screws.
 - Repeat steps 2 & 3 for the other wheel pant.

Tail Wire

1. Collect the following parts:
 - (1) Fuselage
 - (1) Tail Skid Wire
 - (1) 2mm x 3mm Sheet Metal Screw

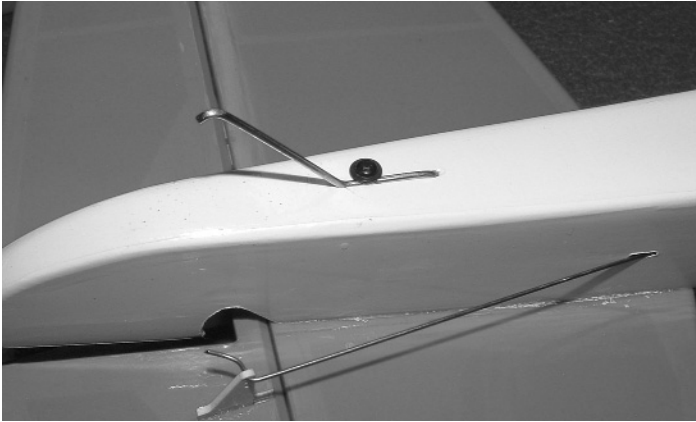

2. Insert the end of the tail skid wire into the fuselage.
 - Screw the wire to the fuselage using the 2mm x 3mm Sheet Metal Screw.

Installing Motor & ESC

1. Collect the following parts:
 - (1) Fuselage
 - (1) Motor with Gear Drive (Not Included)
 - (1) Electronic Speed Control (Not Included)
 - (1) Screw for motor installation (Not Included)

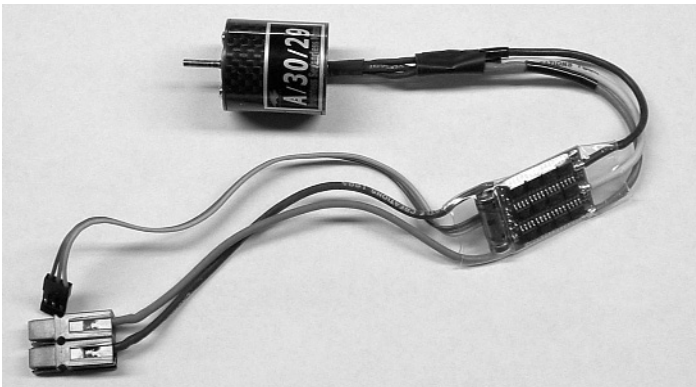

Note:

Read the instructions that come with your motor and speed control for proper wiring. Your Motor and Speed Control might be different than shown.

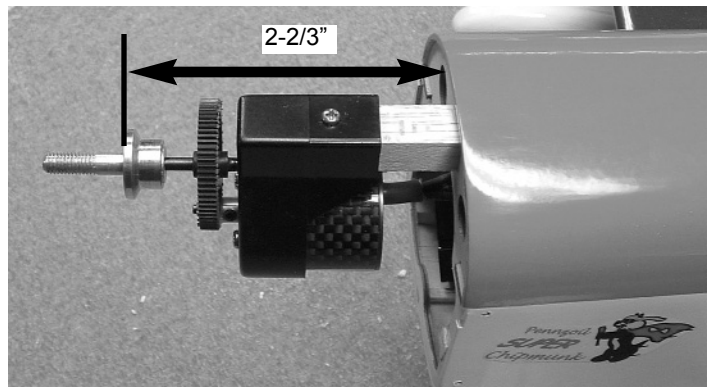

2. We have assembled the motor and gear drive that was provided with the Ultrafly system by the manufactures instructions.
 - Slide the gear drive onto the motor stick till the rear of the prop drive is 2-3/4 away from the firewall.
 - Screw the gear drive to the motor stick.

Caution:

Do Not install the propeller at this time. Electric motors can start turning at any time during radio installation. This can cause damage to the plane or bodily harm.

Installing Cowl

1. Collect the following parts:
 - (1) Fuselage
 - (1) Cowl
 - (4) #2mm x 5 Screws

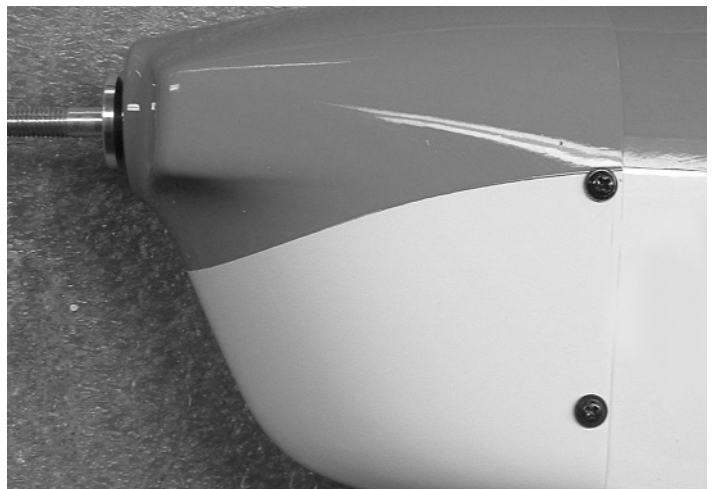

2. Center the prop shaft in the opening of the cowl.
 - Screw the cowl to the side of the fuselage using the #2mm x 5 screws.

Caution:

Do not over tighten the screws. Use CA glue in the screw holes of the fuselage to strengthen the wood.

Radio Installation

- Collect the following parts:
 - (1) Fuselage
 - (2) Micro Servos with Hardware (Not Included)
 - (1) Micro Receiver (Not Included)
 - (1) Servo "Y" Harness (Not Included)
 - (2) Mini- Pushrod Connectors

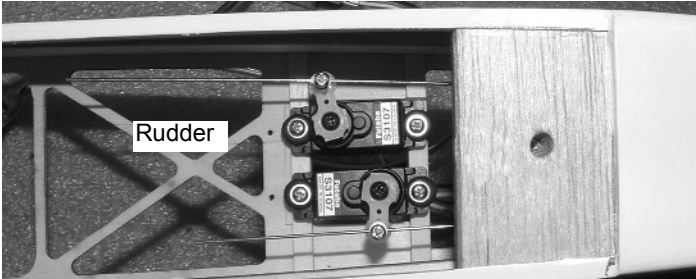

- Mount the elevator and rudder servo as shown above.
 - Attach the EZ connectors to the servo arms the same way you did the aileron servos.
 - Insert the pushrod wires through the EZ connectors and mount the two servo arms to the top of the servos.
 - Cut off the excess pushrod wire.



- Plug the elevator and rudder servos into your receiver.
 - Attach the "Y" harness to the receiver.
 - Plug in the speed control.
 - Cut foam and wrap around the receiver.

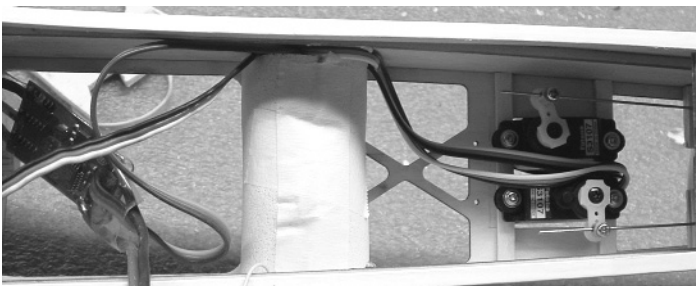

- Put the receiver wrapped in foam in front of the servos.

Battery Installation

- Collect the following parts:
 - (1) Fuselage
 - (1) Wing
 - (1) 4-40 x 3/4 Socket head bolt
 - (1) 3 cell Li-Po Battery



- Mount the wing to the fuselage.
 - Look down through the fuselage hatch and make sure all the radio wires are not pinched between the fuselage and the wing.



- Insert foam into the front battery compartment.
- Slide the Li-Po battery into the front compartment.

Control Set Up

Turn on your transmitter and plug in the receiver battery. Center all the control surfaces (rudder, elevator & aileron). If required by your speed control this is the time to program it for your use.

Control Travel

Aileron up / down 1/2"
Elevator up / down 3/4"
Rudder Right / Left 1"

Propeller



Install the prop adapter and your propeller at this time. We used a 9 x 4.7 APC prop for our motor, battery and speed control setup.

Caution:
The propeller can start turning any time the receiver battery is plugged in.

Decal Locations



- Using glass cleaner and a soft cloth, clean the model surface thoroughly before applying decals.
- Cut the decal sheets apart in sections, as needed.
- Peel the backing off the decal and apply the decal to the plane.

Balancing

Your model should balance 2-1/2" back from the leading edge of the wing next to the fuselage.