

# Stearman PT-17

## Balsawood Scale Airplane

### Instruction Manual

**SCG35**  
**ARF**

#### PRE-FLIGHT CHECKS

- Check/adjust servo centering, in order to adjust the control surface better.
- Double-check the spinning direction of motor at first usage, and sure it's suitable for your model.
- Set the center of gravity (CG) at the position that manual already marked out. If necessary, add weight to the nose or tail to ensure the best flight performance.
- Double-check the inside of the fuselage, make sure all the equipments are correctly connected; Check the heat-shrink covering material's surface, Make certain all screws, bolts, cabin and canopy remain secure.
- Take great care when connecting/disconnecting the battery, pls replace the battery immediately once found low voltage or damage to battery.
- The way the internal devices of the fuselage are connected will be related to your transmitter-receiver device. For those transmitter-receiver devices with more functions, you can simplify the connection of the internal devices of the fuselage. Check your device for details to see if it meets the features you need.
- When the power system and transmitter-receiver device are paired for the first time, you may need to set the maximum stroke of the throttle. Please set it yourself.

#### SAFETY PRECAUTIONS

- **This product should not be considered a toy, but rather a complicated and sophisticated flying model. Your safety depends on how you use and fly it, If not correctly operated, could cause injury to you or your family members. Children must be accompanied by an adult at all times if operating this product. Not suitable for children under the age of 14. THIS IS NOT A TOY.**
- Do not fly around some restricted location like airports, military bases, residential areas, etc.
- You will need to range check the transmitter to be sure you are not experiencing any interference.
- Always turn on the receiver last after turning on the transmitter and shut off the receiver first before turning off the transmitter.
- If you are only a beginner to the radio control model flying, do not attempt to fly your model without any assistance or advice from advanced expert fliers.
- Keep relevant items out of reach of children.
- This product has been flight tested to meet or exceed our rigid performance and reliability standards in normal use,if you plan to perform any high-stress flying, you are solely responsible for taking any and all necessary steps to control movement range and reinforce the body strength.
- This product may include some fiberglass and carbon-fiber reinforced plastic parts,which may cause eye and skin discomfort,pls wear the goggles or dust-proof clothes when needed.
- Due to air traffic safety control, the products you receive may not have the glue that appears in the list. Please understand and purchase the glue you need at your local stationery store.



#### Historical Background

The Stearman PT-17 is a biplane formerly used as a military trainer aircraft, of which at least 10,626 were built in the United States during the 1930s and 1940s. Widely known as the Stearman, Boeing Stearman or Kaydet, it served as a primary trainer for the United States Army Air Forces, the United States Navy (as the NS and N2S), and with the Royal Canadian Air Force as the Kaydet throughout World War II.

#### Specification

Wingspan:1600mm  
Fuselage Length:1200mm  
Flying weight:≈4KG

#### Suggested Equipment

Oil engine: 2-stroke 16cc-20cc Gasoline  
2-stroke 90-120 class Methanol  
(Suggest oil engine: NGH-GT-17)  
Prop: 14-15 inch

Electric motor: Motor : MO3520 600-900KV  
BATT : 4S-6S 5000-6000mAh  
ESC : 80A 4-6S  
Prop : 14 inch

Servo: 37g\*4pcs  
Y wire 1pcs  
30cm extended wire 2pcs

#### Tools Needed



Photos shown here just for reference, the product you received maybe slightly differ from the photos due to continuous improvement on products.



A:Fuselage B1-2:Upper & Lower Wing C:Horizontal wing D:Vertical wing E:Wing joint F1-2:Brackets  
G1:Front landing gear decoration G2:Rear tail wheel decoration H1-2:Landing Gear I:Rear tail wheel  
J:Scale engine K:Scale dashboard L:Sticker M:Parts & Screws

★ **Assembly symbol guide**

	Ensure free rotation		Use medium CA		Use thin CA		Use a pencil
	Push tightly		Use hobby knife with		Fully Tighten		Apply Oil
	Repeat multiple times		Apply threadlock		Assemble right and left		Use epoxy adhesive

**01 Assemble the Landing Gear**

01-1

01-2

01-3

01-4

01-5

Self-tapping screw M1.5x10mm

**02 Assemble the Tail Wing and Tail Wheel**

02-1

02-2

Lubricating oil

Apply oil to the joint of needle hinge (to prevent glue from sticking).



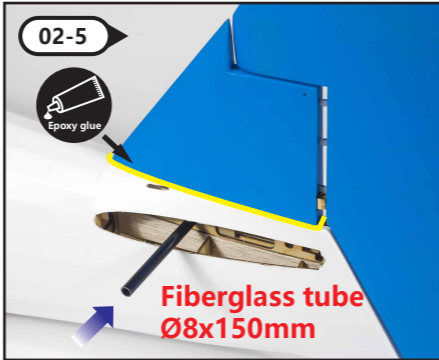
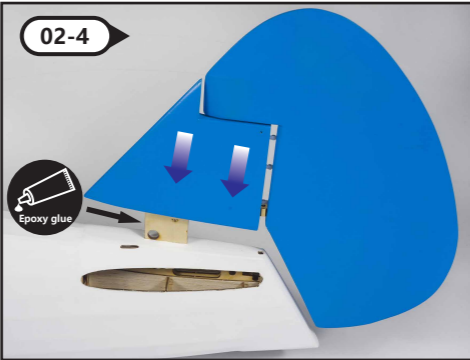
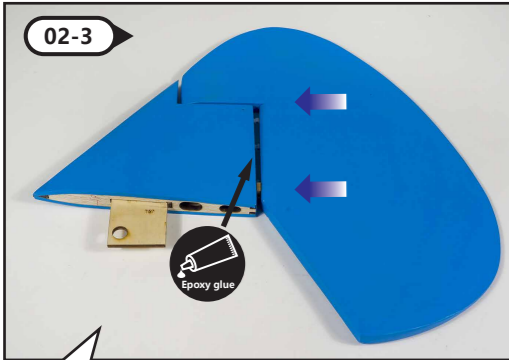

Before installing and fixing the needle hinge, make sure the rudder surface can swing freely.

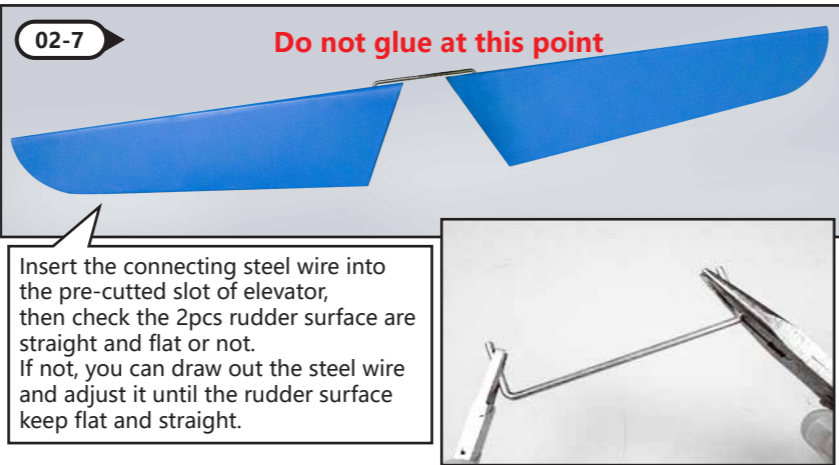
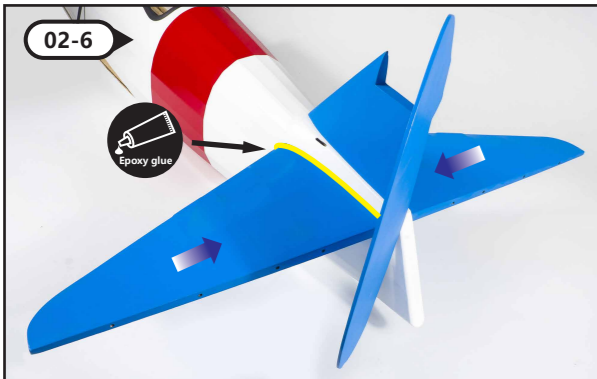

Do not glue at this point  
Insert the connecting steel wire into the pre-cut slot of elevator, then check the 2pcs rudder surface are straight and flat or not. If not, you can draw out the steel wire and adjust it until the rudder surface keep flat and straight.

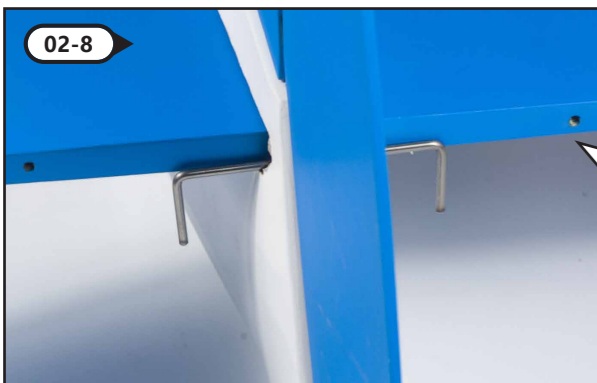

After the adjustment in the previous step, remove the steel wire and insert it into the tail of the fuselage as shown in the left picture.

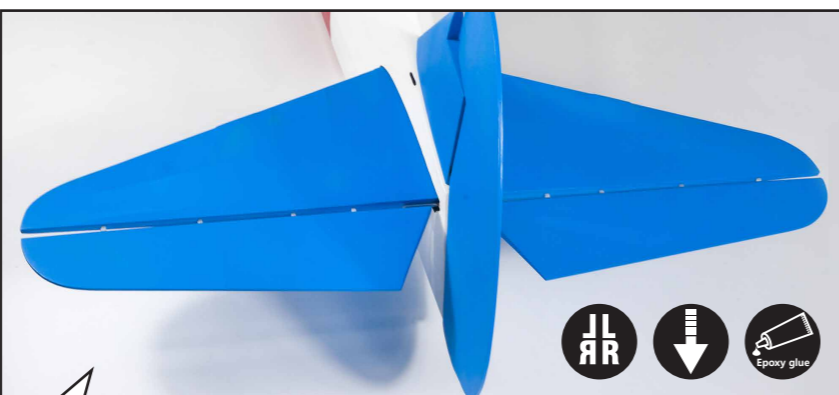

Lubricating oil  
Apply oil to the joint of needle hinge (to prevent glue from sticking).

Insert the needle hinges into the horizontal tail wing, glue elevator to the tail wing and fix with epoxy adhesive. Keep the rudder surface swinging freely when sticking. A small amount of lubricating oil is placed at the moving point of the connecting rod to prevent it from being stuck.

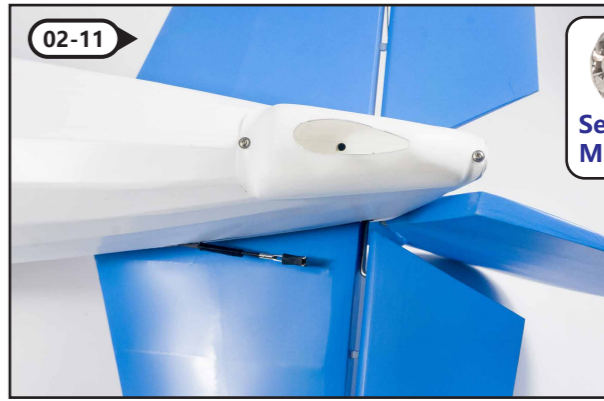
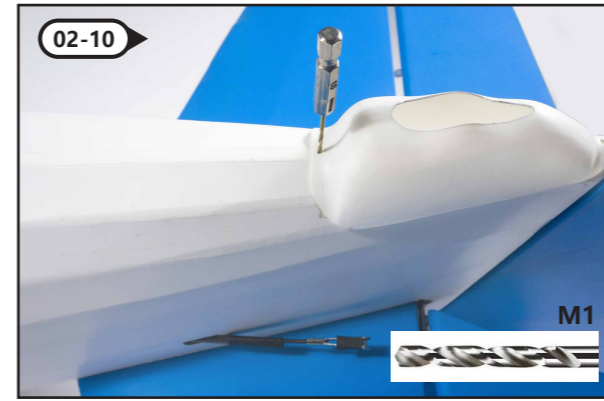

Self-tapping screw M1.5x10mm

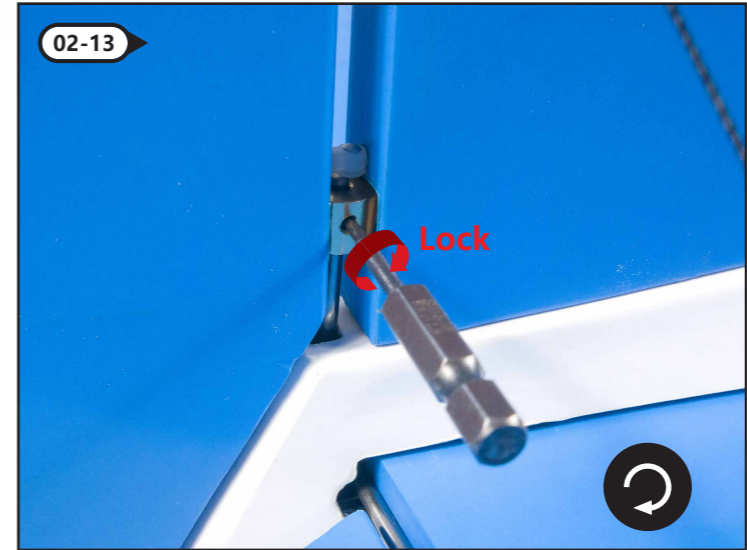

### 03 Assemble the Wing



Apply oil to the joint of needle hinge (to prevent glue from sticking).

Remove the servo cover on the wing and install the servo as shown in the figure. The servo is fixed with small wooden blocks, which are stuck on the cover plate with CA glue.

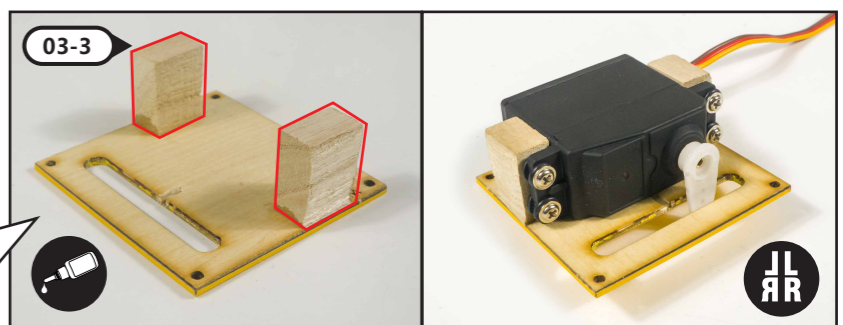



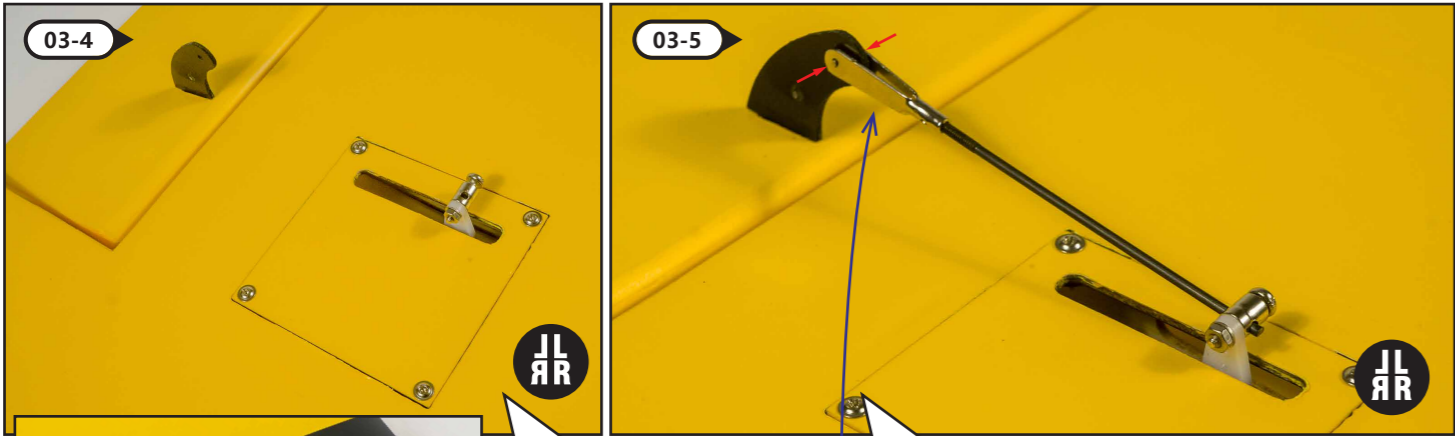

Install the servo cover back into the wing and lock it with self tapping screws. Insert the servo wire into the wing and exits from the side of the wing.

Install the rudder horn in the reserve slot of the aileron, and install the EZ-connector onto the servo arm. Clamp one end of the connecting rod to the rudder horn and insert the other end into the EZ-connector and lock it.

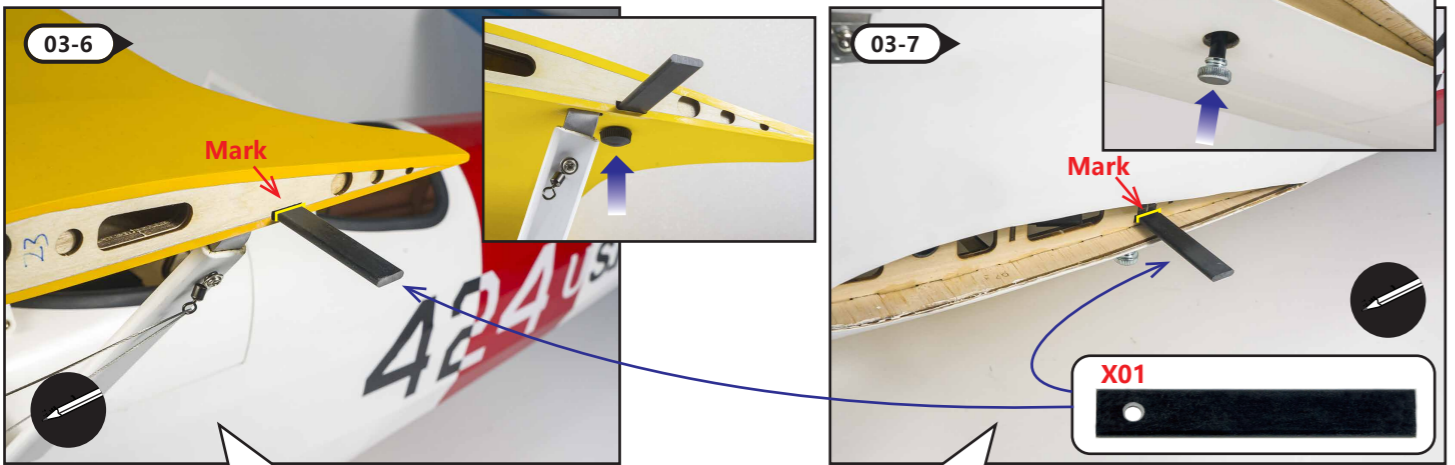

Assemble "X01" on the fuselage, fasten with screw as picture shown. Then mark along the edge. Take out after finish marking.

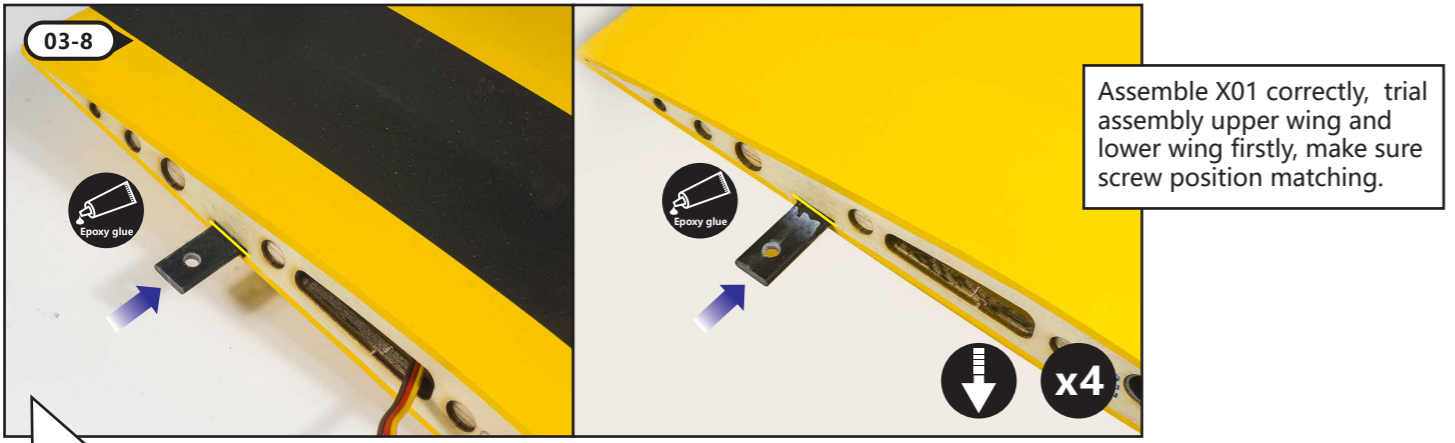

Assemble "X01" on the wing which marked on step 03-6 and 03-7, according to above picture, the marked position keeps aligned with the leading edge of wing, glue with epoxy adhesive after adjustment.



Insert the carbon piece X02 in the reserve slot of upper and lower wing, and glue with epoxy adhesive.

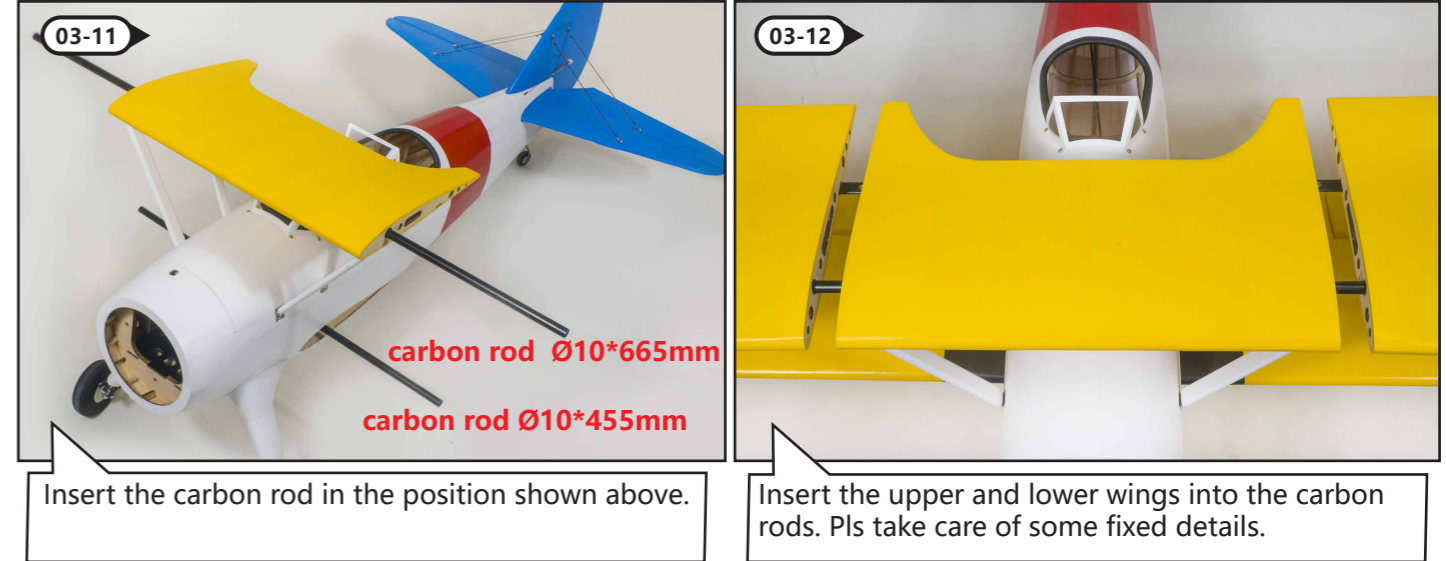
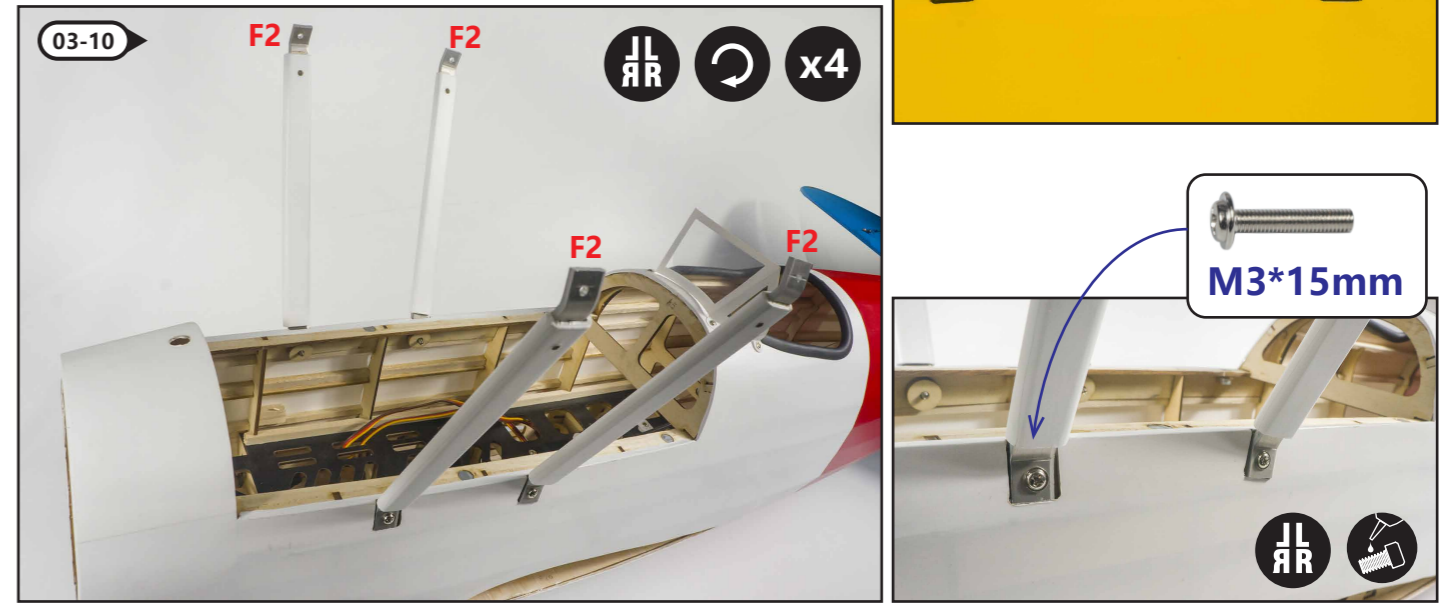

Insert the carbon rod in the position shown above.

Insert the upper and lower wings into the carbon rods. Pls take care of some fixed details.



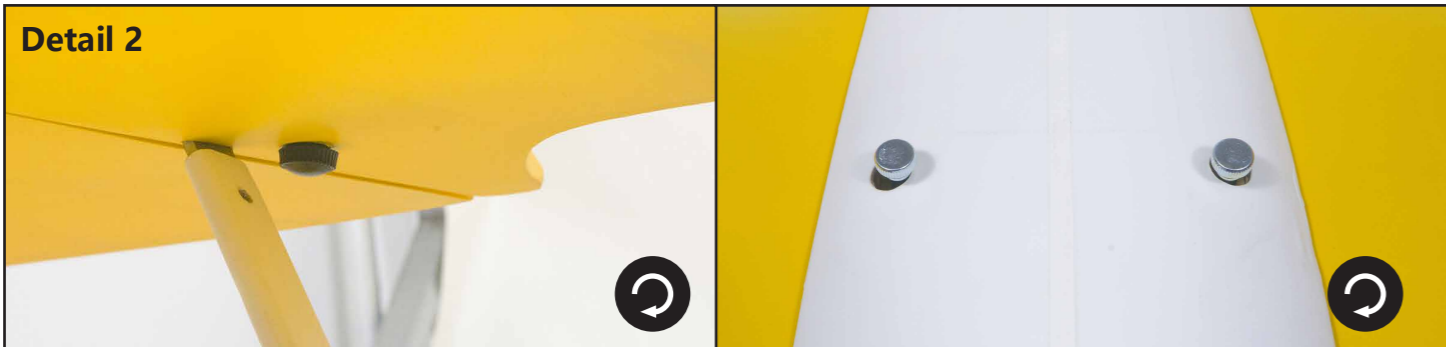
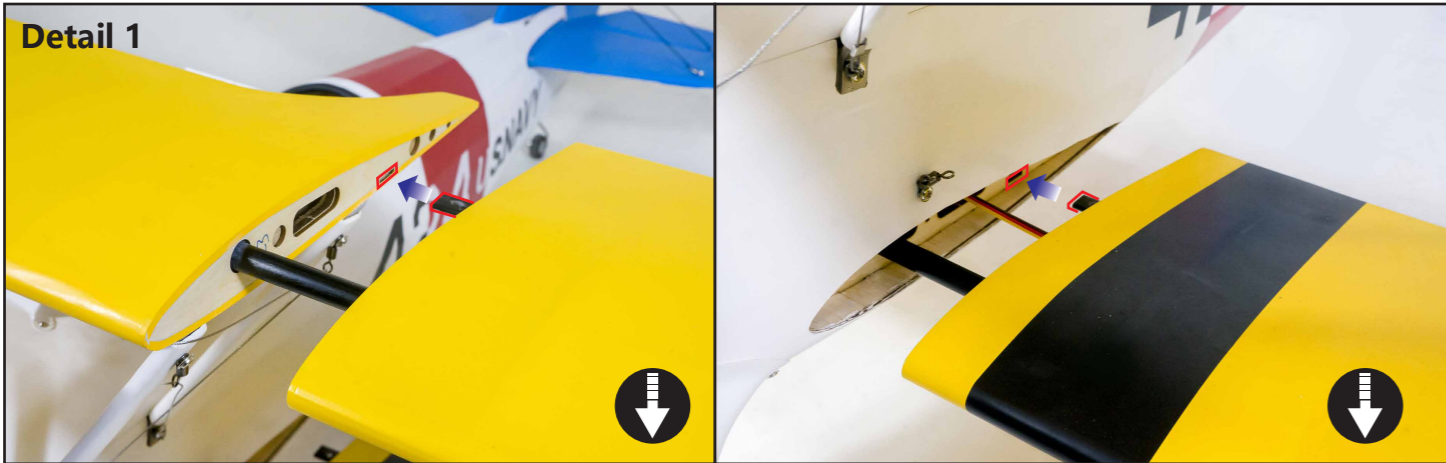

Insert the wings into the fuselage and tighten the screws to secure.

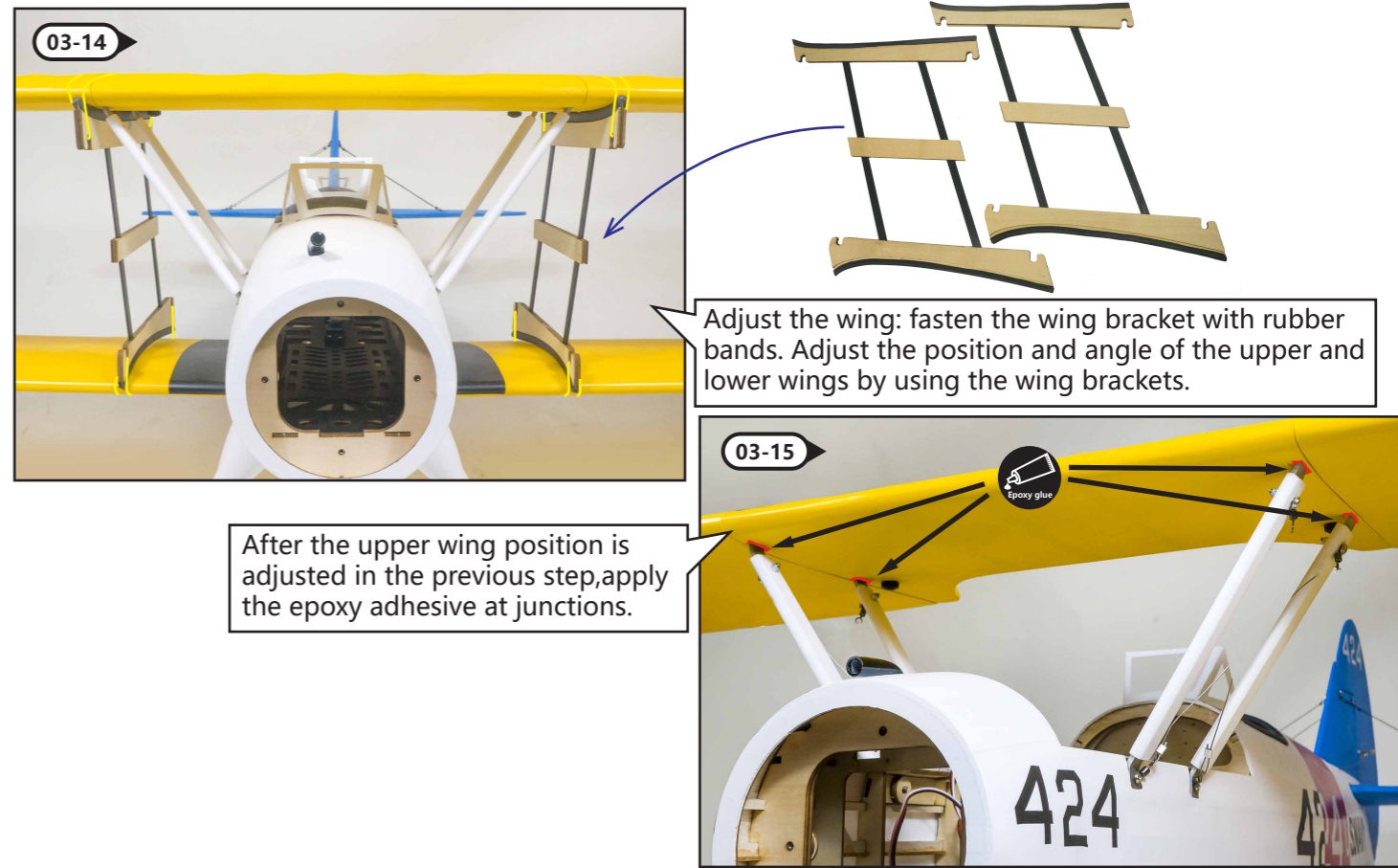
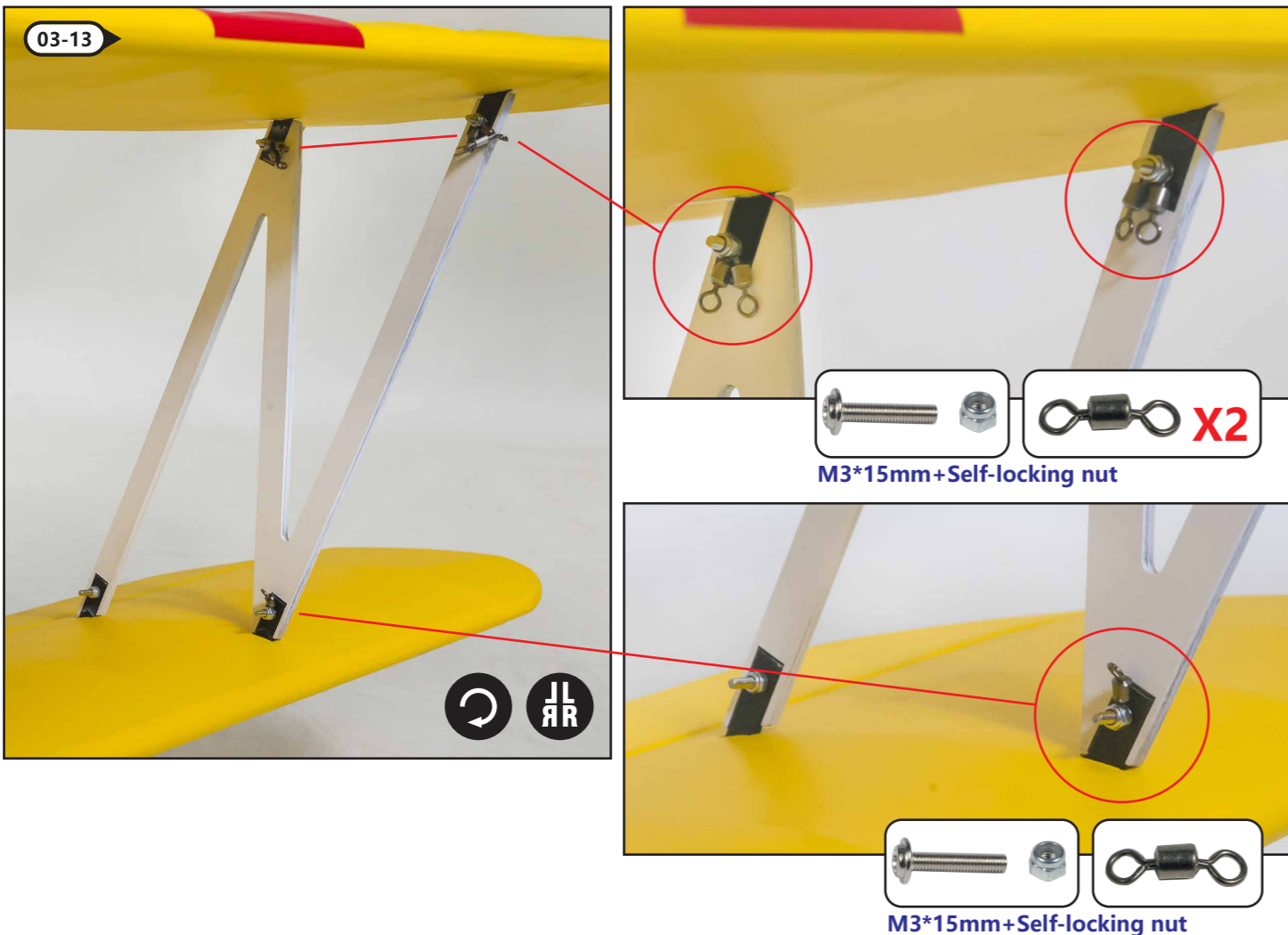

**04 Install the rudder steering gear and connecting rod**

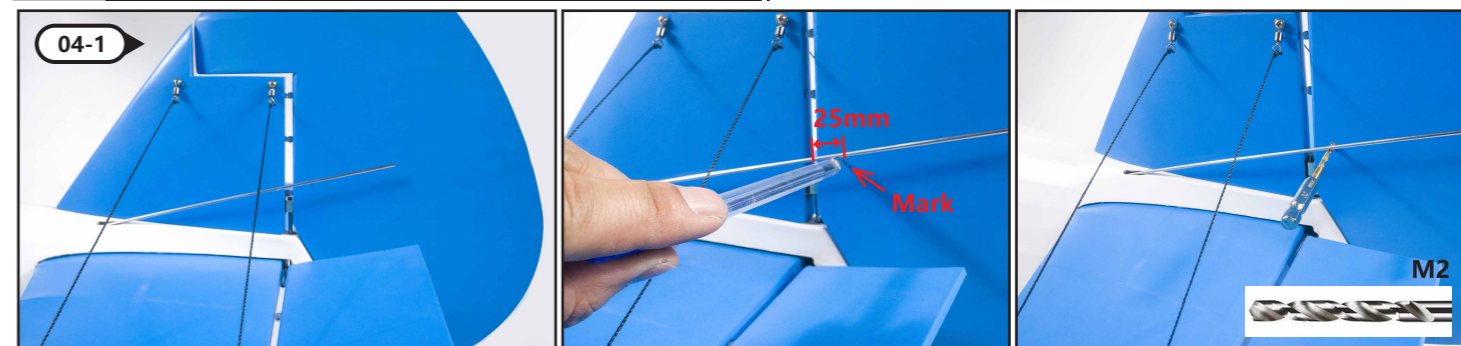

Insert a steel wire into the fuselage and extend to the steering gear position. Then referring to the position where the wire is exposed, a mark is made on the rudder surface with a pen for the vertical rudder and a hole is drilled at the mark position

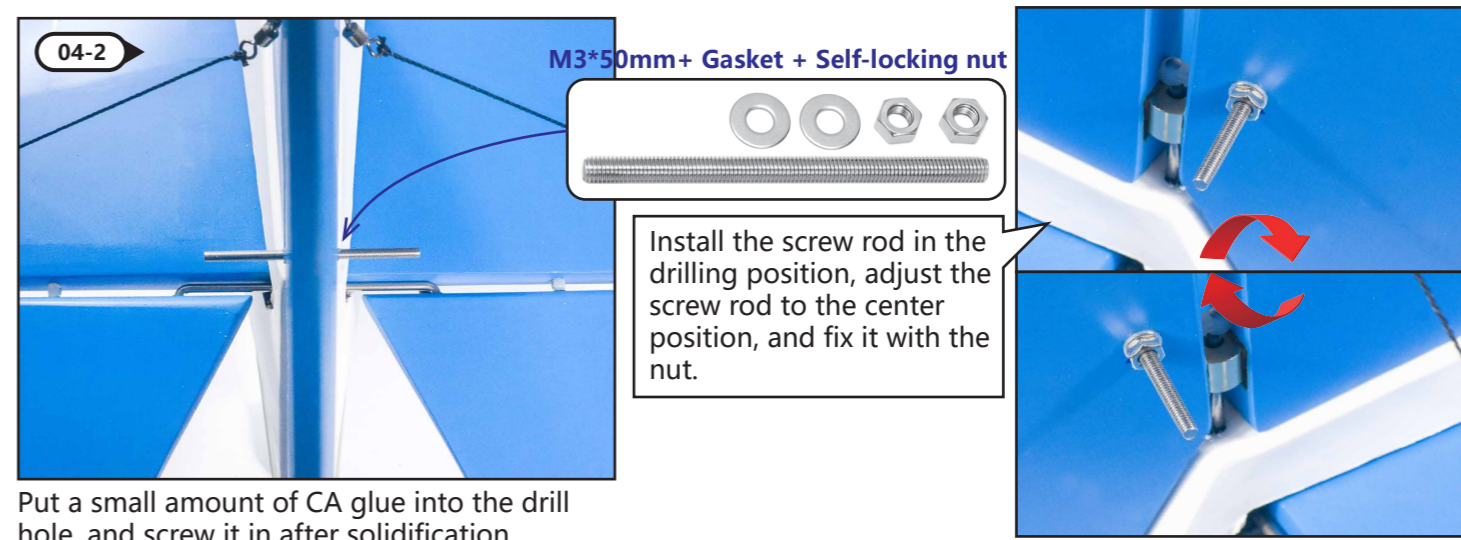

Put a small amount of CA glue into the drill hole, and screw it in after solidification.





Insert the elevator connecting rod into the fuselage and extend it to the steering gear. Mark the elevator on the other end with a pen according to the position above. Drill a hole at the mark position and install the screw.



Install two servos inside the fuselage as shown on the left.

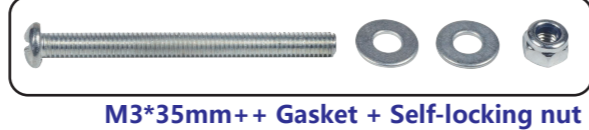

Install servo arm and EZ-connector on a servo near the airplane head, and fix one end of connecting rod reserved in the fuselage to the EZ-connector.

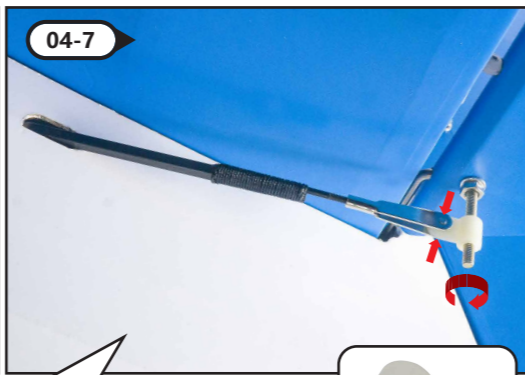

The other end of connecting rod is fixed as shown in the figure above.

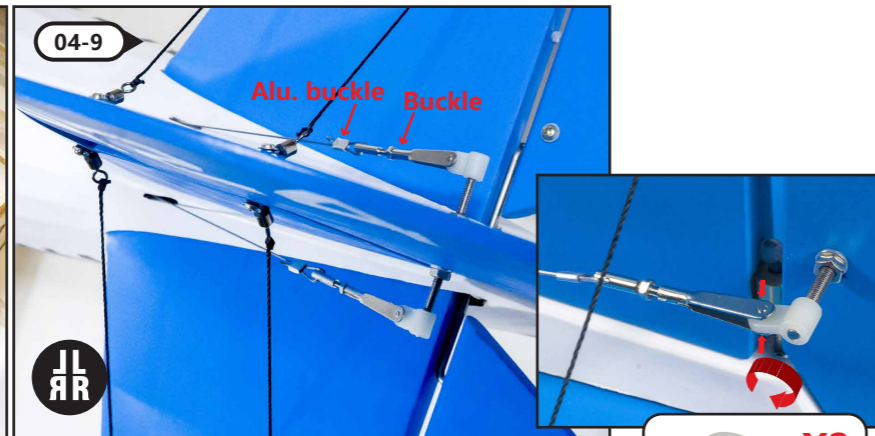
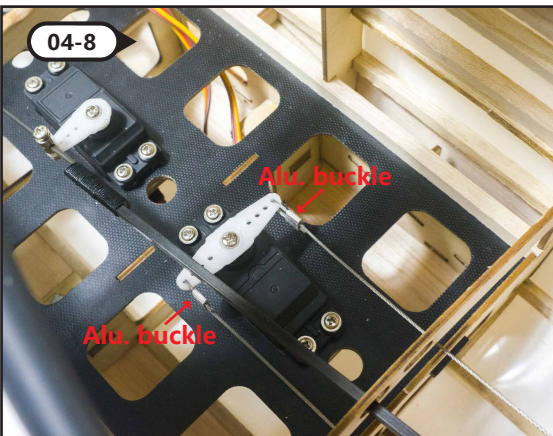

Install the "-" shape servo arm on the other servo, and install the steel wires on both ends. The wire is derived from the reserved hole at the rear of the fuselage, and then connected with the rudder. (Refer to figure 04-9 for connection)



05 Install the wiring cable



Check the two small blocks inside the fuselage and drill a hole on each from the outside.

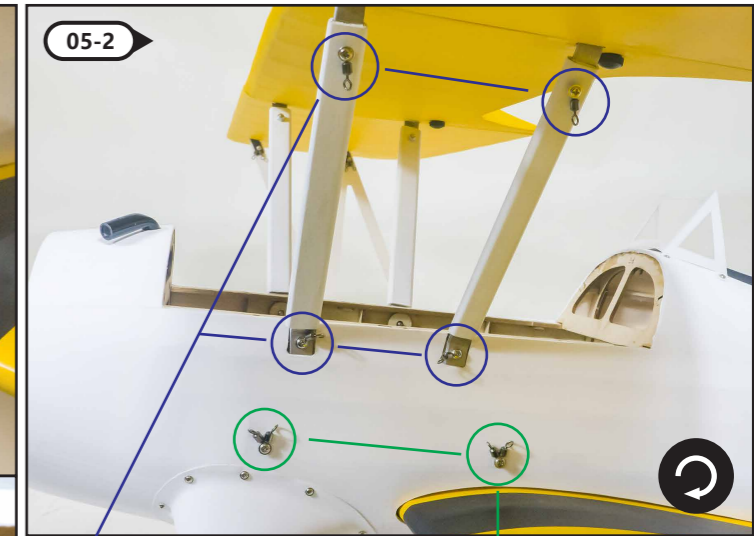

1. Put a small amount of CA glue into the drill hole, and fix the connecting ring by self-tapping screw after get dried.

2. Install the connecting rings at positions marked in blue.

Display the wiring for wing

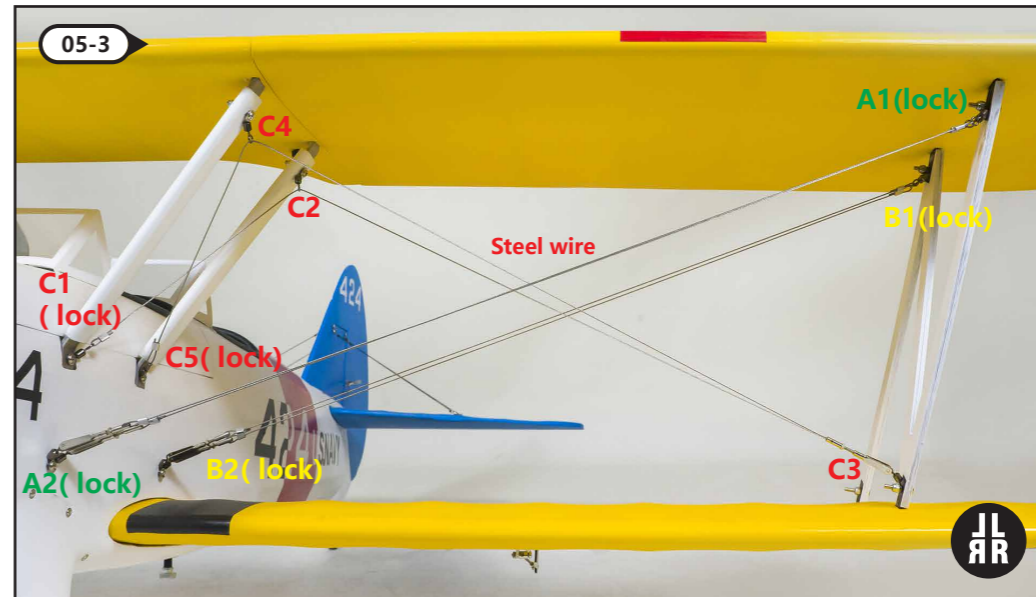

There are totally five wiring cables for this PT-17, pls identify them by color and proceed the wiring by numerical order.

Pay attention to details when installing.

A1→A2 two wiring  
B1→B2 two wiring  
C1→C2→C3→C4→C5



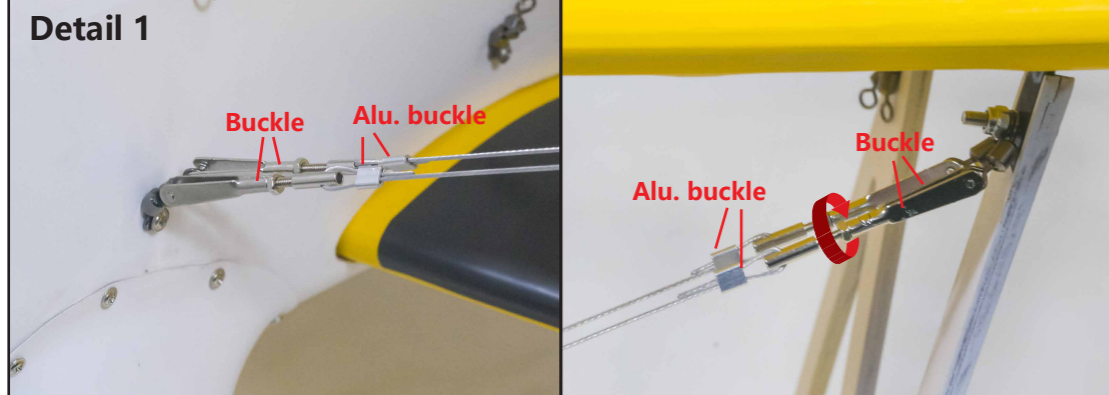

Display the wiring for tail wing

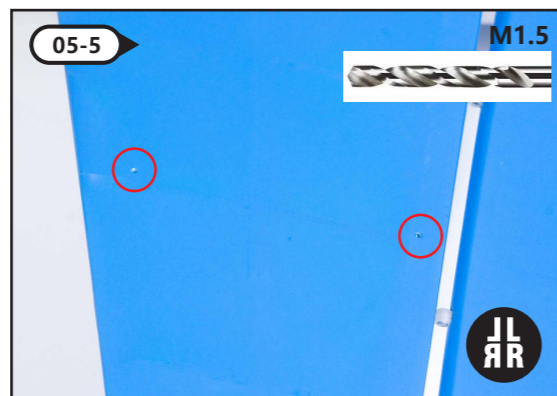
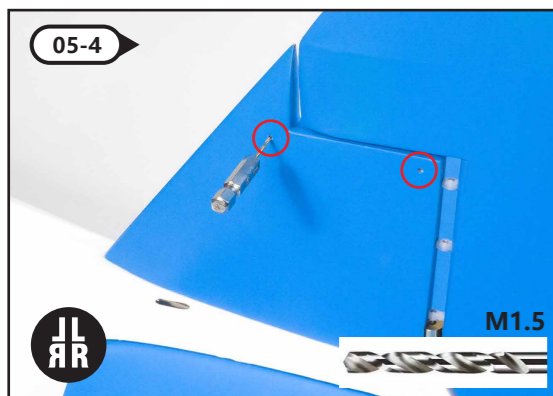

Drill two holes at the mark positions of the horizontal tail as shown above and put a small amount of CA glue into the drill hole.

Drill two holes at the mark positions of the vertical tail as shown above and put a small amount of CA glue into the drill hole.

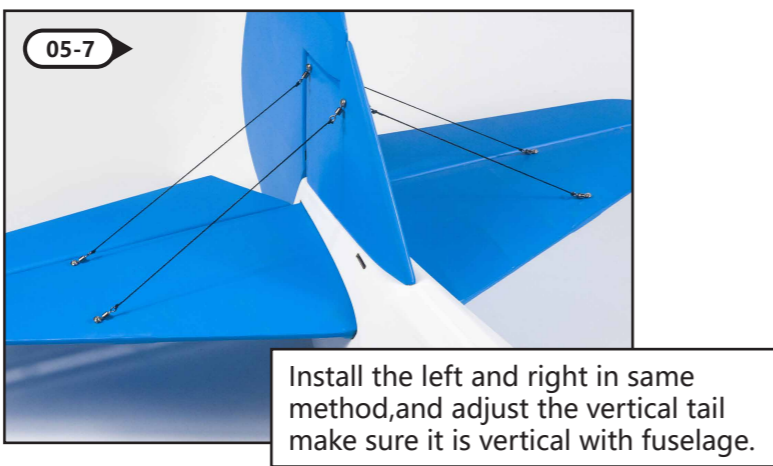
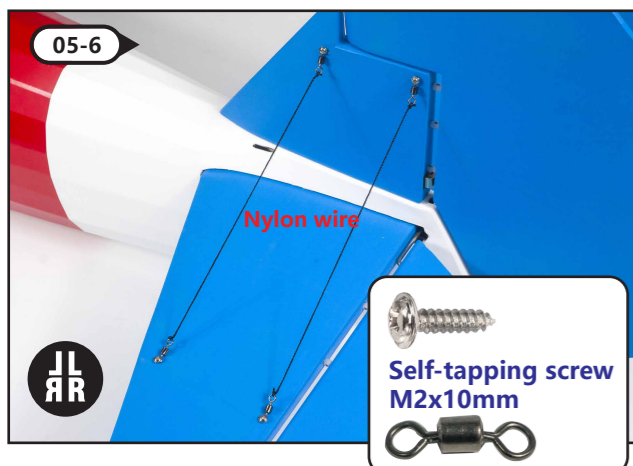

06 Install the engine and scale parts

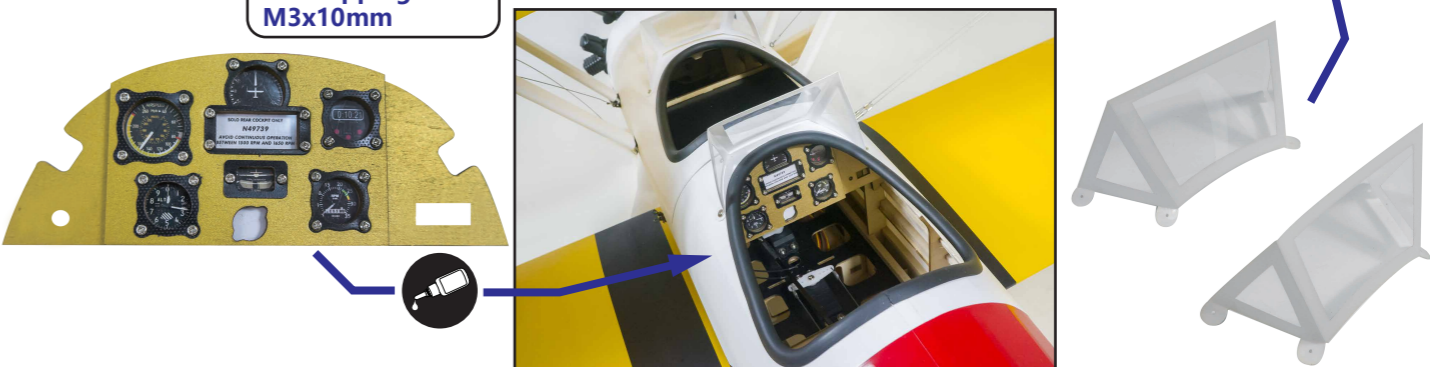
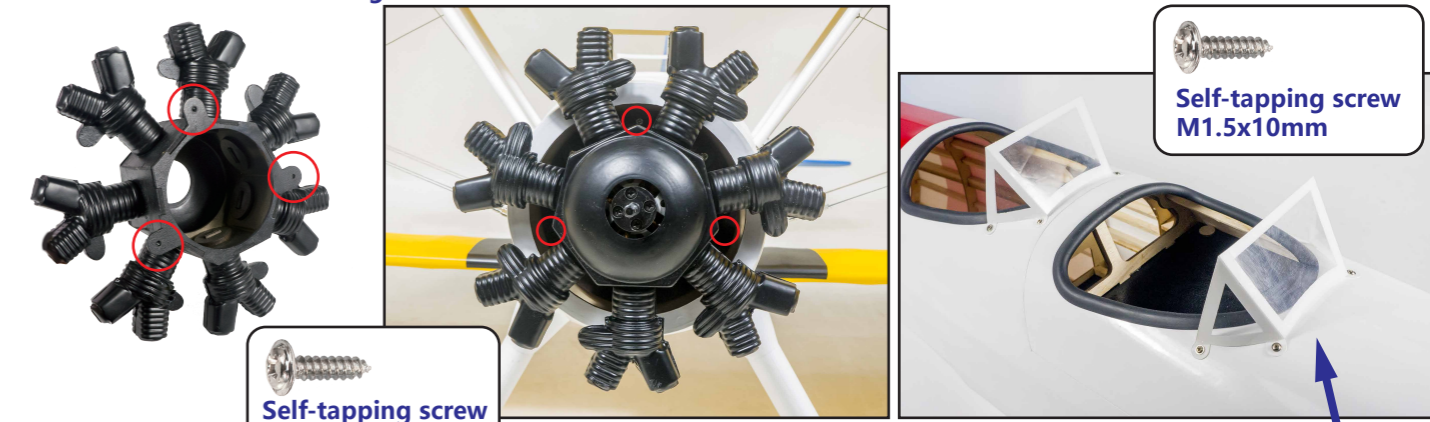
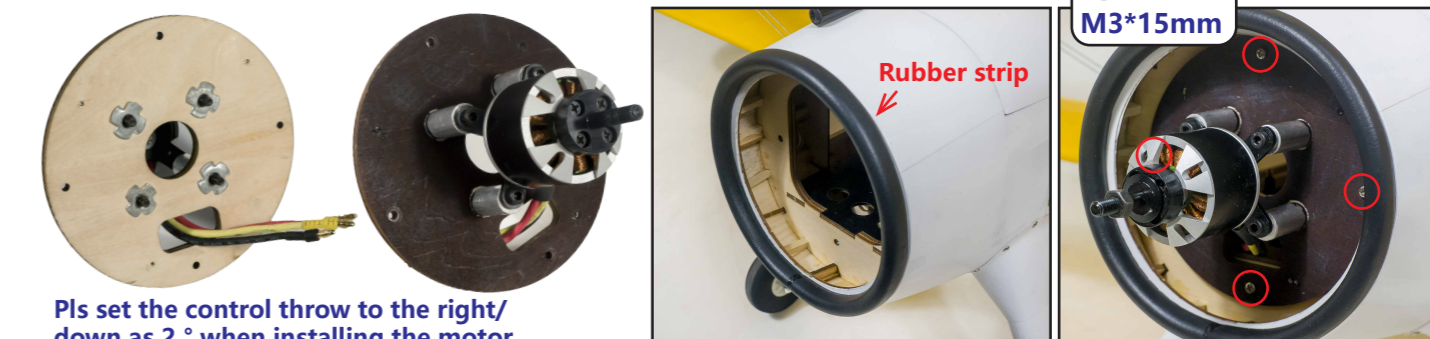

07 Set and Adjust

Display the C.G

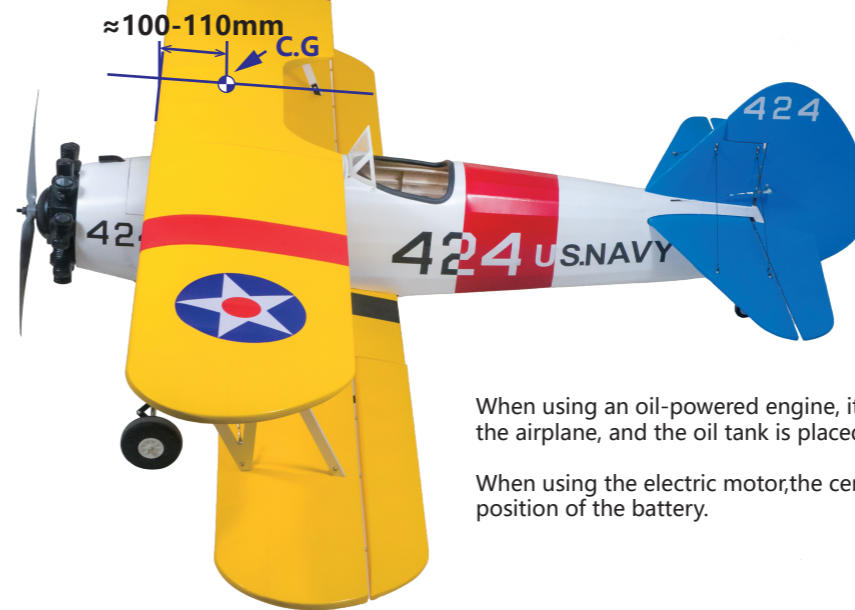

When using an oil-powered engine, it may be necessary to counterweight the head of the airplane, and the oil tank is placed at the center of gravity.

When using the electric motor, the center of gravity can be adjusted by adjusting the position of the battery.



# Stearman PT-17 Instruction Manual

Usually, the control throws set as below:

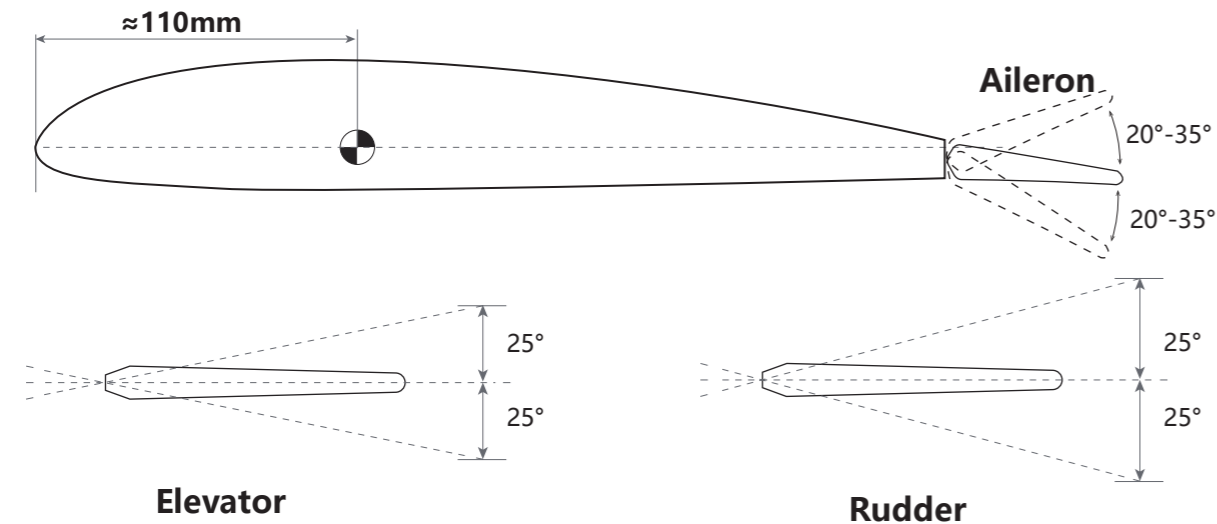

	Elevator	Rudder
Normal Flying		3D Flying only support some models
Aileron	± (15°-30°)	±40° or larger
Elevator	±15°	±40° or larger
Rudder	±15°	±40° or larger
Flap	take-off 15°-20°	Landing 20°-40°

Some special models will have V-tails, flaps, leading edge wings, etc., which can be used as a reference for conventional flight angles. If you do not confirm and there is no experienced person to guide you, we recommend that you first test at a small angle to confirm that your settings are correct.

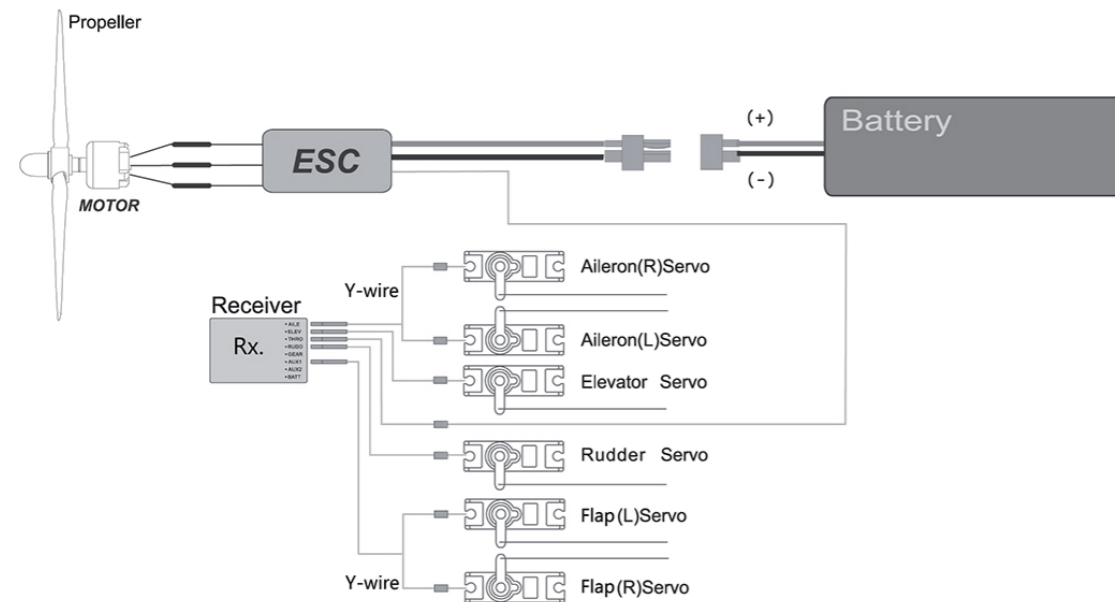

- Note 1: If you need motor reversed rotation, please exchange discretionary two wires in three motor wires.
- Note 2: Before power on, please confirm the transmitter joystick on the position of **minimum throttle**.
- Note 3: Usually, **when you use the ESC at the first time**, you need to confirm the max limit of the throttle before normal start.
- Note 4: Different receivers with different meaning, usually CH1=Aileron CH2=Elevator CH3=Throttle CH4= Rudder CH5=Landing Gear CH6=AUX1 CH7=AUX2...
- About the channel of steering and flap wing, you can connect according to your own way.
- Note 5: Before servo installation, please set up "back to centre point after power on" in advance.

## Control Directions Tests

	Transmitter Command	Aircraft Reaction
Elevator	Lifting rod down	
	Lifting rod up	
Aileron	Steering rod to the right	
	Steering rod to the left	
Rudder	Direction rod to the right	
	Direction rod to the left	