

BLADE[®]

TR:O 180 CFX



**Instruction Manual
Bedienungsanleitung
Manuel d'utilisation
Manuale di Istruzioni**

BNF[®]
BASIC

AS3X[®]

NOTICE

All instructions, warranties and other collateral documents are subject to change at the sole discretion of Horizon Hobby, LLC. For up-to-date product literature, visit horizonhobby.com and click on the support tab for this product.

Meaning of Special Language

The following terms are used throughout the product literature to indicate various levels of potential harm when operating this product:

NOTICE: Procedures, which if not properly followed, create a possibility of physical property damage AND a little or no possibility of injury.

CAUTION: Procedures, which if not properly followed, create the probability of physical property damage AND a possibility of serious injury.

WARNING: Procedures, which if not properly followed, create the probability of property damage, collateral damage, and serious injury OR create a high probability of superficial injury.



WARNING: Read the ENTIRE instruction manual to become familiar with the features of the product before operating. Failure to operate the product correctly can result in damage to the product, personal property and cause serious injury.

This is a sophisticated hobby product. It must be operated with caution and common sense and requires some basic mechanical ability. Failure to operate this Product in a safe and responsible manner could result in injury or damage to the product or other property. This product is not intended for use by children without direct adult supervision. Do not use with incompatible components or alter this product in any way outside of the instructions provided by Horizon Hobby, LLC. This manual contains instructions for safety, operation and maintenance. It is essential to read and follow all the instructions and warnings in the manual, prior to assembly, setup or use, in order to operate correctly and avoid damage or serious injury.

Age Recommendation: Not for children under 14 years. This is not a toy.

Safety Precautions and Warnings

- Always keep a safe distance in all directions around your model to avoid collisions or injury. This model is controlled by a radio signal subject to interference from many sources outside your control. Interference can cause momentary loss of control.
- Always operate your model in open spaces away from full-size vehicles, traffic and people.
- Always carefully follow the directions and warnings for this and any optional support equipment (chargers, rechargeable battery packs, etc.).
- Always keep all chemicals, small parts and anything electrical out of the reach of children.
- Always avoid water exposure to all equipment not specifically designed and protected for this purpose. Moisture causes damage to electronics.
- Never place any portion of the model in your mouth as it could cause serious injury or even death.
- Never operate your model with low transmitter batteries.
- Always keep aircraft in sight and under control.
- Always move the throttle fully down at rotor strike.
- Always use fully charged batteries.
- Always keep transmitter powered on while aircraft is powered.
- Always remove batteries before disassembly.
- Always keep moving parts clean.
- Always keep parts dry.
- Always let parts cool after use before touching.
- Always remove batteries after use.
- Never operate aircraft with damaged wiring.
- Never touch moving parts.



WARNING AGAINST COUNTERFEIT PRODUCTS: If you ever need to replace a Spektrum component found in a Horizon Hobby product, always purchase from Horizon Hobby, LLC or a Horizon Hobby authorized dealer to ensure authentic high-quality Spektrum product. Horizon Hobby, LLC disclaims all support and warranty with regards, but not limited to, compatibility and performance of counterfeit products or products claiming compatibility with DSM or Spektrum technology.

BLADE® TRIO 180 CFX

Table of Contents

First Flight Preparation.....	4	Saving the Gain Adjustments	13
Flying Checklist	4	Blade Trio 180 CFX Servo Adjustment	13
Transmitter Setup	4	Entering Servo Adjustment Mode	13
Installing the Flight Battery	6	Adjusting the Servo Neutral Position	14
Transmitter and Receiver Binding.....	7	Swashplate Leveling	14
Throttle Hold	7	Saving the Servo Adjustments.....	14
Control Tests.....	7	Blade 180 CFX Troubleshooting Guide.....	15
Blade Trio 180 CFX Pre-Flight Checklist	9	Exploded View	16
Flying the Blade Trio 180 CFX.....	9	Replacement Parts.....	17
Low Voltage Cutoff (LVC)	10	Optional Parts	17
Gyro Gain Adjustment	10	Limited Warranty	17
Post-Flight Inspections and Maintenance	10	Warranty and Service Contact Information	19
Advanced Settings.....	11	FCC Information.....	19
Gain Parameters	11	IC Information.....	19
Entering Gain Adjustment Mode.....	12	Compliance Information for the European Union.....	19
Adjusting the Gain Values.....	12		

Specifications

Length	13.4 in (340mm)	Tail Rotor Diameter	3.6 in (90.5mm)
Height	5.1 in (130mm)	Flying Weight	7.7 oz (220 g)
Main Rotor Diameter	14.2 in (360mm)		

Box Contents

- Blade® Trio 180 CFX

Required Items

- DSM2®/DSMX® compatible transmitter
- 450mAh 3S 11.1V 30C Li-Po Battery
- 3S LiPo compatible battery charger

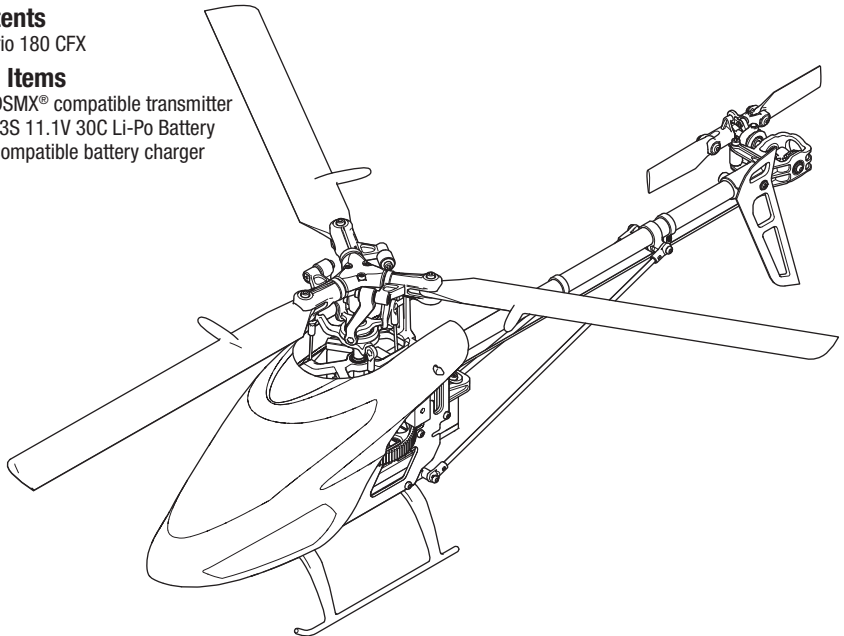

To receive product updates, special offers and more, register your product at www.bladehelis.com.

Main Rotor Installation

Install the main rotor blades as shown using 3, 1.5 mm socket head screws provided.

Do not overtighten the screws in the blade grips. The screws should be just tight enough so some friction is felt when you move the blades, but still loose enough for the blades to move easily.



CAUTION: Do not use thread locking compound on the screws or grips. Thread locking compound will degrade the blade grip material and could cause a failure of the grip.

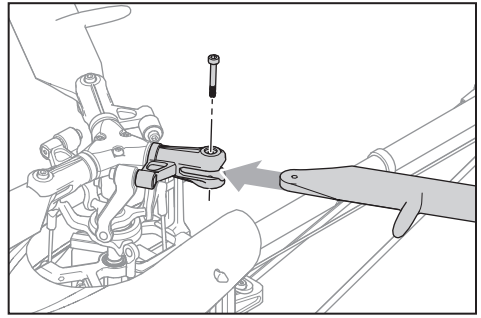

First Flight Preparation

- Remove and inspect contents
- Begin charging the flight battery
- Install the flight battery in the helicopter (once it has been fully charged)
- Program your computer transmitter
- Bind your transmitter
- Familiarize yourself with the controls
- Find a suitable area for flying

Flying Checklist

- Always turn the transmitter on first**
- Plug the flight battery into the lead from the ESC
- Allow the receiver and ESC to initialize and arm properly
- Fly the model
- Land the model
- Unplug the flight battery from the ESC
- Always turn the transmitter off last**

Transmitter Setup

Program your transmitter before attempting to bind or fly the helicopter. Transmitter programming values are shown below for the *Spektrum* DX6i, DX7s, DX8, DX7 (Gen2), DX8 (Gen2), DX9, DX18 and DX20.

The files for models using *Spektrum*™ transmitters with *AirWare*™ software are also available for download online in the Spektrum Community.

Please refer to your transmitter manual for more information on programming throttle hold and normal flight mode.

DX6i

SETUP LIST		ADJUST LIST										
Model Type		TRAVEL ADJ				D/R & Expo						
HELI		Channel	Travel			Chan	Sw Pos	D/R	Expo			
		THRO	100/100			AILE	0	100	+25			
		AILE	100/100				1	75	+25			
Swash Type		ELEV	100/100			ELEV	0	100	+25			
1 servo 90		RUDD	100/100				1	75	+25			
REVERSE		GYRO	100/100			RUDD	0	100	+25			
Channel	Direction	PITC	100/100				1	75	+25			
THRO	N	Throttle Curve										
AILE	N	Switch Pos (F Mode)	Pos 1	Pos 2	Pos 3	Pos 4	Pos 5	GYRO				
ELEV	N	NORM	0	25	25	25	25	100	RATE	SW-F.MODE		
RUDD	N	STUNT	100	100	100	100	100	100	0	50%	NORM	0
GYRO	N	HOLD	0	0	0	0	0	0	1	50%	STUNT	1
PITC	R	Pitch Curve										
D/R COMBI		Switch Pos (F Mode)	Pos 1	Pos 2	Pos 3	Pos 4	Pos 5					
D/R SW	AILE	NORM	30	40	50	75	100					
Timer		STUNT	0	25	50	75	100					
Down Timer	3:00	HOLD	0	25	50	75	100					
Switch	THR CUT											
Modulation Type												
AUTO DSMX-ENABLE												

DX7s, DX8

SYSTEM SETUP	
Model Type	
HELI	
Swash Type	
1 servo Normal	
F-Mode Setup	
Flight Mode	F Mode
Hold	Hold
SW Select	
Trainer	AUX 2
F Mode	Gear
Gyro	INH
Mix	INH
Hold	INH
Knob	INH
Frame Rate	
11ms	
DSMX	

FUNCTION LIST												
Servo Setup												
Chan	Travel	Reverse	Chan	Travel	Reverse							
THR	100/110	Normal	GER	100/100	Normal							
AIL	100/100	Normal	PIT	100/100	Normal							
ELE	100/100	Normal	AX2	100/100	Normal							
RUD	100/100	Normal										
D/R & Expo					Throttle Curve							
Chan	Switch Pos (Ail D/R)		D/R	Expo	Switch Pos (F Mode)							
	DX7s	DX8			Pt 1	Pt 2	Pt 3	Pt 4	Pt 5			
AILE	0	0	100/100	0	N	N	0	25	25	25	25	
	1	1	85/85	0	1	1	75	75	75	75	75	
	1	2	85/85	0	1	2	100	100	100	100	100	
ELEV	0	0	100/100	0	HOLD	HOLD	0	0	0	0	0	
	1	1	85/85	0								
	1	2	85/85	0								
RUDD	0	0	100/100	0								
	1	1	85/85	0								
	1	2	85/85	0								
Gyro					Pitch Curve							
Normal					Switch Pos (F Mode)	DX7s	DX8	Pt 1	Pt 2	Pt 3	Pt 4	Pt 5
Stunt 1	75%				N	N	30	40	50	75	100	
Hold	75%				1	1	0	25	50	75	100	
Channel	Gear				1	2	0	25	50	75	100	
SW	F Mode				HOLD	HOLD	0	25	50	75	100	
Timer												
Mode						Count Down						
Time						3:00 Tone						
Start						Throttle Out						
Over						25%						

DX6, DX6e, DX7 (Gen 2), DX8 (Gen 2), DX9, DX18, DX20

SETUP LIST	
Model Type	
HELI	
Swash Type	
Normal	
F-Mode Setup	
Switch 1	Switch B
Switch 2	Inhibit
Hold Switch	Switch H
Channel Assign	
Channel Input Config	
1 Throttle	
2 Aileron	
3 Elevator	
4 Rudder	
5 Gear	Switch B
6 Aux 1	
Frame Rate	
11ms	
DSMX	

FUNCTION LIST										
Servo Setup										
Chan	Travel	Reverse	Chan	Travel	Reverse					
THR	100/110	Normal	GER	100/100	Normal					
AIL	100/100	Normal	PIT	100/100	Normal					
ELE	100/100	Normal	AX2	100/100	Normal					
RUD	100/100	Normal								
D/R & Expo					Pitch Curve					
Chan	Switch (F) Pos			D/R	Expo	Switch (B) Pos				
	DX6	DX7, 8, 9, 18, 20				Pt 1	Pt 2	Pt 3	Pt 4	Pt 5
AILE	0	0	100/100	0	N	30	40	50	75	100
	1	1	85/85	0	1	0	25	50	75	100
	1	2	85/85	0	2	0	25	50	75	100
ELEV	0	0	100/100	0	HOLD	0	25	50	75	100
	1	1	85/85	0						
	1	2	85/85	0						
RUDD	0	0	100/100	0						
	1	1	85/85	0						
	1	2	85/85	0						
Throttle Curve					Gyro					
Switch (B) Pos	Pt 1	Pt 2	Pt 3	Pt 4	Pt 5	Pos 0	75%			
N	0	25	25	25	25	Pos 1	75%			
1	75	75	75	75	75	Pos 2	75%			
2	100	100	100	100	100	Channel	Gear			
HOLD	0	0	0	0	0	SW	B			
Timer										
Mode						Count Down				
Time						3:00				
Start						Throttle Out				
Over						25%				
One Time						Inhibit				

Installing the Flight Battery

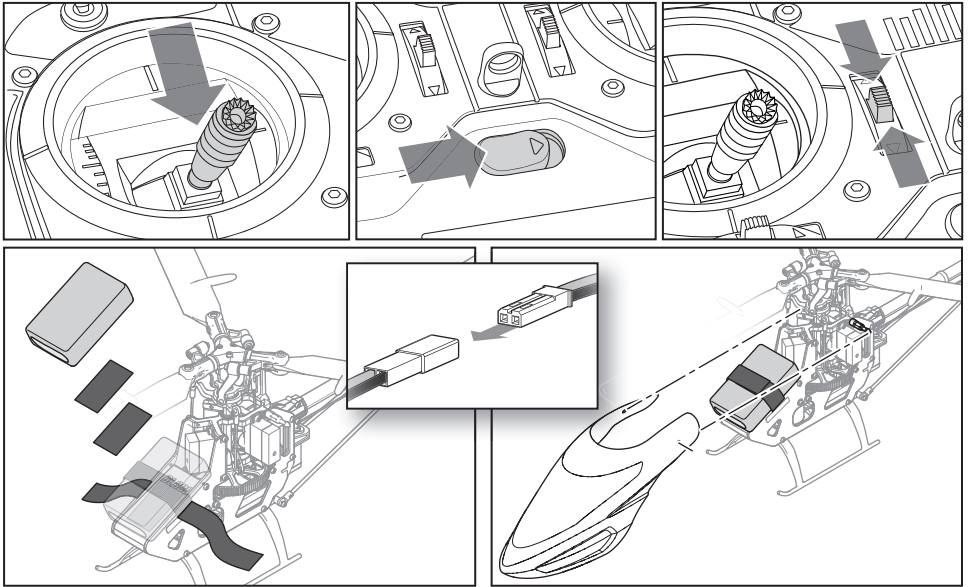

1. Lower the throttle.
2. Power on the transmitter.
3. Center the throttle trim.
4. To allow the ESC to arm and to keep rotors from initiating at startup, turn on throttle hold and normal flight mode before connecting the flight battery.
5. Attach hook material to the helicopter frame and loop material to the battery.
6. Install the flight battery on the helicopter frame. Secure the flight battery with a hook and loop strap. Connect the battery cable to the ESC.

CAUTION: Always keep the power lead positioned AWAY from the elevator servo. Failure to do so could cause the lead to get caught and will result in crash causing property damage and injury.

CAUTION: Make sure the flight battery does not come in contact with the motor. Failure to do so will cause the motor, ESC and battery to overheat, resulting in crash, causing property damage and injury.

7. Do not move the helicopter until the receiver initializes. The LED on the receiver glows solid when the helicopter is initialized.
8. The helicopter motor will emit 2 tones, indicating the ESC is armed.



CAUTION: Always disconnect the Li-Po battery from the aircraft receiver when not flying to avoid over-discharging the battery. Batteries discharged to a voltage lower than the lowest approved voltage may become damaged, resulting in loss of performance and potential fire when batteries are charged.

Transmitter and Receiver Binding

Binding is the process of programming the receiver to recognize the GUID (Globally Unique Identifier) code of a single specific transmitter. You need to 'bind' your chosen

Spektrum™ DSM2/DSMX technology equipped aircraft transmitter to the receiver for proper operation.

Binding Procedure

1. Disconnect the flight battery from the helicopter.
2. Refer to the Transmitter Setup Table to correctly set up your transmitter.
3. Lower the throttle and throttle trim to the lowest position.
4. Power off the transmitter and move all switches to the 0 position.
5. Install the bind plug in the bind port extension.
6. Connect the flight battery to the ESC. The receiver LED flashes, indicating it is in bind mode.
7. Put the transmitter into bind mode while powering on the transmitter.
8. Release the bind button/switch after 2–3 seconds. The helicopter is bound when the LED on the receiver turns solid.
9. Disconnect the flight battery and remove the bind plug. Store the bind plug in a convenient place.

NOTICE: Remove the bind plug to prevent the system from entering bind mode the next time the power is turned on.

If you encounter problems, obey binding instructions and refer to transmitter troubleshooting guide for other instructions. If needed, contact the appropriate Horizon Product Support office. For a list of compatible DSM transmitters, please visit www.bindnfly.com.

Throttle Hold

Throttle hold only turns off the motor on an electric helicopter. You must maintain pitch and direction control.

The blades will spin if throttle hold is OFF. For safety, turn throttle hold ON any time you need to touch the helicopter or check the direction controls.

Throttle hold is also used to turn off the motor if the helicopter is out of control, in danger of crashing, or both.

Please refer to your transmitter manual for more information on programming throttle hold.

Control Tests

Test the controls prior to the first flight to ensure the servos, linkages and parts operate correctly. Turn on Throttle Hold when doing the control tests.

Elevator

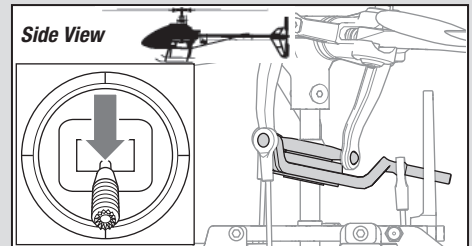
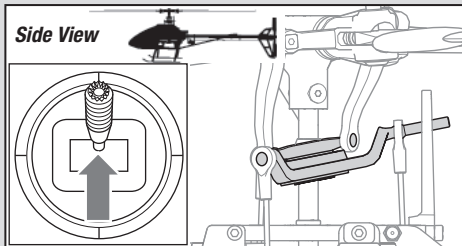

Aileron

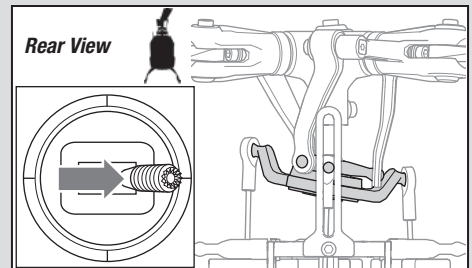
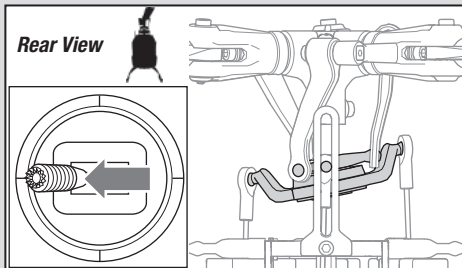

Rudder

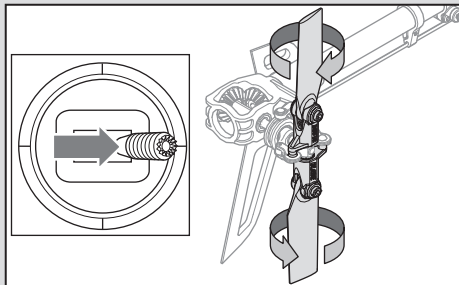
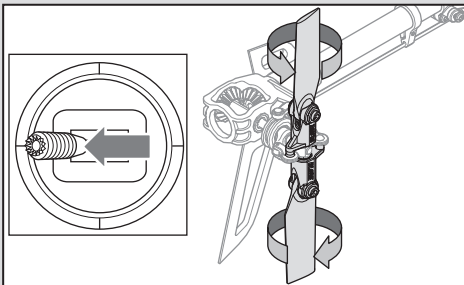

Collective Pitch

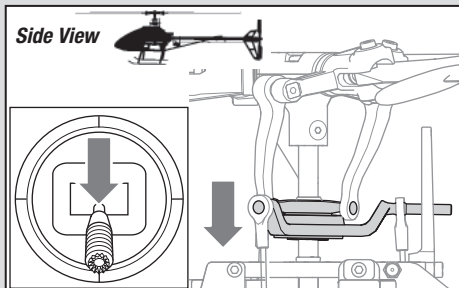
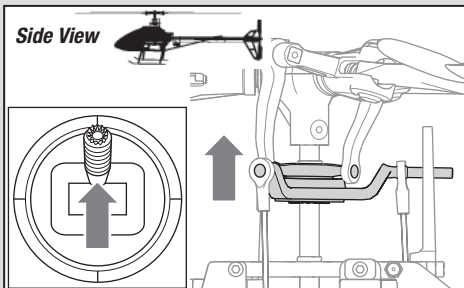

Motor Control Test

Place the helicopter outdoors on a clean, flat and level surface (concrete or asphalt) free of obstructions. Always stay clear of moving rotor blades.

1. The motor beeps twice when the helicopter's ESC arms properly. Before you continue, confirm that TH HOLD is ON.



WARNING: The motor will spin when throttle is increased while TH HOLD is OFF.

2. Check the swashplate directions to ensure they are moving in the correct direction. Please refer to the diagrams above for reference.



WARNING: Stay at least 30 feet (10 meters) away from the helicopter when the motor is running. Do not attempt to fly the helicopter at this time.

3. Set the transmitter to normal flight mode. Ensure the throttle is lowered completely. Turn throttle hold off at this time. Slowly increase the throttle until the blades begin to spin. The main blades spin clockwise when viewing the helicopter from the top. The tail rotor blades spin counterclockwise when viewing the helicopter from the right-hand side.

NOTICE: If the main rotor blades are spinning counterclockwise, reduce the throttle to low immediately. Turn throttle hold on. Disconnect the battery from the helicopter and reverse any two motor wire connections to the ESC and repeat the motor control test.

Blade Trio 180 CFX Pre-Flight Checklist

- Check all screws to ensure that they are tight
- Check main and tail blades to ensure they are not damaged
- Check all links to make sure they move freely, but do not pop off easily
- Check that flight battery and transmitter battery are fully charged
- Check all wires to ensure that they are not cut, pinched, or chafed and are properly secured
- Check all wire connections
- Check gears to make sure no teeth are missing
- Do a complete control test
- Check that the servos are functioning properly
- Check to make sure the flight battery is properly secured
- Check to make sure the receiver is properly secured

Flying the Blade Trio 180 CFX

Consult local laws and ordinances before choosing a location to fly your aircraft.

Select a large, open area away from people and objects. Your first flights should be outdoors in low-wind conditions. Always stay at least 30 feet (10 meters) away from the helicopter when it is flying.

The Blade 180 CFX is intended to be flown outdoors or inside a large gymnasium.

Takeoff

Increase the throttle to quickly establish a hover at least 24" (0.6 meter) high, outside of ground effect.



CAUTION: Do not give any aileron, elevator or rudder commands before takeoff or the helicopter may crash during takeoff.

Flying

The helicopter lifts off the ground when the rotor head reaches a suitable speed. Establish a low-level hover outside of ground effect to verify proper operation of your helicopter. You must not set any trim; the flybarless design of the Blade 180 CFX renders trim unnecessary. Setting trim or sub-trim can cause an unwanted drift or rotation of the helicopter.

First flights should be performed in normal mode and low cyclic and rudder dual rates until you are familiar with the flying manner of the Blade 180 CFX. Discover the rates that fit your flying style.



CAUTION: Always try to fly the helicopter with your back to the sun and the wind to prevent loss of flight control.

Landing

Establish a low level hover. Gently lower the throttle until the helicopter lands. Do not give any aileron, elevator or rudder commands when the helicopter touches down.

Flight Modes

Normal Mode: This mode has a low head speed and limited negative collective pitch available. It should be used for takeoff, landing and very mild upright flight. Never attempt to fly inverted in Normal Mode.

Stunt 1 Mode: This mode has a constant moderate head speed and full range of rotor collective pitch available.

Stunt 2 Mode: This mode has a constant high head speed and full range of rotor collective pitch available.

DX6i and DX7s users: Your transmitter is limited to 2 flight modes. The transmitter setup table values show how to program your transmitter for Normal Mode and Stunt 2 Mode as your available flight modes. If you would prefer Stunt 1 Mode over Stunt 2 Mode, change the STUNT values of the Throttle Curve to 85%.

When the helicopter is in stunt mode:

- The rotor head speed is constant.
- The main rotor will increase negative pitch as the throttle/collective stick is moved from the middle stick position to the low stick position. Negative pitch allows the helicopter to fly upside down and perform aerobatics.

Change between stunt and normal modes in a hover with the throttle near the hovering stick position.

The helicopter may go up or down when you change between modes due to the difference in the throttle and pitch curves.

If the cyclic control is too slow or too fast, adjust the transmitter dual rates, expo or throttle curve to fit your liking.

For advanced AS3X settings please go to Bladeheli.com and refer to the 180 CFX page.

Low Voltage Cutoff (LVC)

Once the battery reaches 9V under load, the ESC will continuously lower power supplied to the motor until complete shutdown occurs. This helps prevent over-discharge of the Li-Po battery. Land immediately once the ESC activates LVC. Continuing to fly after LVC can damage the battery, cause a crash or both. Crash damage and batteries damaged due to over-discharge are not covered under warranty.

Repeatedly flying the helicopter until LVC activates will damage the helicopter battery.

Disconnect and remove the Li-Po battery from the aircraft after use to prevent trickle discharge. During storage, make sure the battery charge does not fall below 3V per cell.

Gyro Gain Adjustment

If the tail wags or oscillates, lower the gain on the gyro. On your transmitter's gyro menu, decrease the gyro gain values a small amount until the helicopter is stable within a particular flight mode.

If the tail is drifting while hovering, increase the gain on the gyro. On your transmitter, increase the gyro gain values a small amount at a time until the tail starts to wag/oscillate. Afterwards, reduce the gain until the tail stops wagging/oscillating within a particular flight mode.

Post-Flight Inspections and Maintenance

Ball Links	Make sure the plastic ball link holds the control ball, but is not tight (binding) on the ball. When a link is too loose on the ball, it can separate from the ball during flight and cause a crash. Replace worn ball links before they fail.
Cleaning	Make sure the battery is not connected before cleaning. Remove dust and debris with a soft brush or a dry lint-free cloth.
Bearings	Replace bearings when they become notchy (sticky in places when turning) or draggy.
Wiring	Make sure the wiring does not contact moving parts. Replace damaged wiring and loose connectors.
Fasteners	Make sure there are no loose screws, other fasteners or connectors. Do not over tighten metal screws in plastic parts. Tighten screw so parts are mated together, then turn screw only 1/8th of a turn more.
Rotors	Make sure there is no damage to rotor blades and other parts which move at high speed. Damage to these parts includes cracks, burrs, chips or scratches. Replace damaged parts before flying.
Gyro	Make sure the receiver is securely attached to the frame. Replace the double-sided tape when necessary. The helicopter will crash if the receiver separates from the helicopter frame.

Advanced Settings

The 180 CFX default settings are appropriate for most users. We recommend flying with the default parameters before making any adjustments.



WARNING: To ensure your safety, always disconnect the motor wires from the ESC before performing the following steps. After you have completed the adjustments, reconnect the motor wires to the ESC before attempting to fly the model.

Before accessing the Gain Parameter Adjustment or Servo Adjustment, you must assign channel 7 (AUX2) to the bind switch on the transmitter.

Transmitter	Channel Input Configuration	Reversing Setup
DX6, DX6i, DX6e	No setup required	
DX7s, DX7 (G2), DX8, DX8 (G2), DX9, DX18, DX20	7(AUX2): Switch I	AX2 = Reverse

Gain Parameters

1. Cyclic P Gain Adjustment (Default 100%)

Higher gain will result in greater stability. Setting the gain too high may result in random twitches if your model has an excessive level of vibration. High frequency oscillations may also occur if the gain is set too high.

Lower gain will result in less stability. Too low of a value may result in a less stable model particularly outdoors in winds.

If you are located at a higher altitude or in a warmer climate, higher gains may be beneficial—the opposite is true for lower altitude or colder climates.

2. Cyclic I Gain Adjustment (Default 100%)

Higher gain will result in the model remaining still, but may cause low frequency oscillations if increased too far.

Lower gain will result in the model drifting slowly.

If you are located at a higher altitude or in a warmer climate, higher gains may be beneficial—the opposite is true for lower altitude or colder climates.

3. Cyclic D Gain Adjustment (Default 100%)

Higher gain will improve the response rate of your inputs. If the gain is raised too much, high frequency oscillations may occur.

Lower gain will slow down the response to inputs.

4. Cyclic Response (Default 100%)

Higher cyclic response will result in a more aggressive cyclic response.

Lower cyclic response will result in a less aggressive cyclic response.

5. Tailrotor P Gain Adjustment (Default 100%)

Higher gain will result in greater stability. Setting the gain too high may result in random twitches if your model has an excessive level of vibration. High frequency oscillations may also occur if the gain is set too high.

Lower gain may result in a decrease in stability. Too low of a value may result in a less stable model particularly outdoors in winds.

If you are located at a higher altitude or in a warmer climate, higher gains may be beneficial—the opposite is true for lower altitude or colder climates.

6. Tailrotor I Gain Adjustment (Default 100%)

Higher gain results in the tail remaining still. If the gain is raised too far, low speed oscillations may occur.

Lower gain will result in the tail drifting in flight over time.

If you are located at a higher altitude or in a warmer climate, higher gains may be beneficial—the opposite is true for lower altitude or colder climates.

7. Tailrotor D Gain Adjustment (Default 100%)

Higher gain will improve the response rate to your inputs. If raised too far, high frequency oscillations may occur.

Lower gain will slow down the response to inputs, but will not have an effect on stability.

Entering Gain Adjustment Mode

DX6, DX6e and DX6i Users:

1. Lower the throttle stick to the lowest position.
2. Power ON the transmitter.
3. Install the flight battery on the helicopter frame, securing it with the hook and loop strap.
4. Connect the battery connector to the ESC.
5. Before initialization is complete, move and hold both transmitter sticks to the bottom right corner as shown.

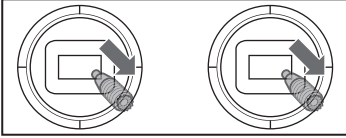

6. When the servos move, you have entered Gain Adjustment Mode.
7. Release the sticks and proceed to Adjusting the Gain Values to make any desired changes.

DX7s, DX7 (G2), DX8, DX8 (G2), DX9, DX18 and DX20 Users:

1. Lower the throttle stick to the lowest position.
2. Power ON the transmitter.
3. Install the flight battery on the helicopter frame, securing it with the hook and loop strap.
4. Connect the battery connector to the ESC.
5. Place the helicopter on a flat surface and leave it still until the orange receiver LED glows solid, indicating initialization is complete.
6. Move and hold both transmitter sticks to the bottom right corner as shown.

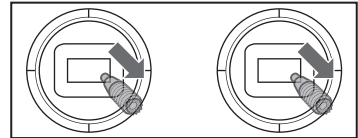

7. Press and hold the bind/panic switch until the swash servos move.
8. Release the sticks and the bind/panic switch. The model is now in Gain Adjustment Mode.
9. Proceed to Adjusting the Gain Values to make any desired changes.

Adjusting the Gain Values

If you are using a Spektrum™ telemetry-enabled transmitter, the gain adjustments can be viewed on the Flight Log screen. Refer to your transmitter instructions to locate this screen. The gain parameter currently selected will flash

on the transmitter screen. If you are not using a Spektrum telemetry-enabled transmitter, the parameter and gain values are indicated by the position of the swashplate on the helicopter.

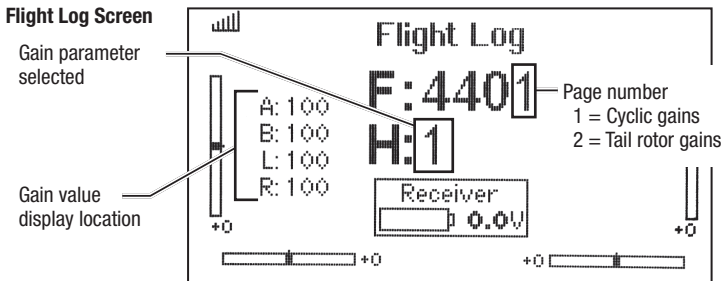

Once you have entered Gain Adjustment Mode, you can move the cyclic stick right and left to select the gain parameter you would like to adjust. Moving the stick right will select the next parameter. Moving the stick left will select the previous parameter.

The selected gain parameter is indicated on the Flight Log screen and by the lean of the swashplate on the roll axis.

Parameter #	Display location	Swash Position	Page #
1	A	100% to the Left	1
2	B	50% to the Left	1
3	L	25% to the Left	1
4	R	Swashplate Level	1
5	A	25% to the Right	2
6	B	50% to the Right	2
7	L	100% to the Right	2

The current gain value for the selected parameter is indicated on the Flight Log screen and by the angle of the swashplate (forward or backward) as shown in the table below.

Swash Position	Gain Value
Full backward	0%
50% backward	50%
Level forward and backward	100%
50% forward	150%
Full forward	200%

Move the cyclic stick forward or backward to adjust the gain value. Moving the stick *forward* will increase the gain value. Moving the stick *backward* will decrease the gain value.

It is always best to adjust one gain at a time. Make small adjustments (5% or less) and test fly the model to evaluate the adjustments that were made.

If you would like to reset the current gain value to the default value of 100%, move and hold the rudder stick full right for 1 second. The swash will level on the pitch axis, indicating a 100% gain setting.

Saving the Gain Adjustments

DX6, DX6e and DX6i Users:

1. Lower the throttle stick to the lowest position and release the sticks.
2. Move the tail rotor stick to the left and hold until the servos move.
3. Release the tail rotor stick to save the gain adjustments.
4. Reconnect the main drive motor to the ESC. Your model is now ready for flight.

DX7s, DX7 (G2), DX8, DX8 (G2), DX9, DX18 and DX20 Users:

1. Lower the throttle stick to the lowest position and release the sticks.
2. Press and hold switch I until the swash servos move.
3. Release switch I to save the gain adjustments.
4. Reconnect the main drive motor to the ESC. Your model is now ready for flight.

Blade Trio 180 CFX Servo Adjustment

Your Blade 180 CFX was setup at the factory and test flown. The servo adjustment steps are usually only necessary in special circumstances, such as after a crash or if a servo or linkage is replaced.



WARNING: To ensure your safety, always disconnect the motor wires from the ESC before performing the following steps. After you have completed the adjustments, reconnect the motor wires to the ESC before attempting to fly the model.

Entering Servo Adjustment Mode

DX6, DX6e and DX6i Users:

1. Lower the throttle stick to the lowest position.
2. Power ON the transmitter.
3. Install the flight battery on the helicopter frame, securing it with the hook and loop strap.
4. Connect the battery connector to the ESC.
5. Before initialization is complete, hold the left stick to the bottom left corner and the right stick to the bottom right corner as shown.

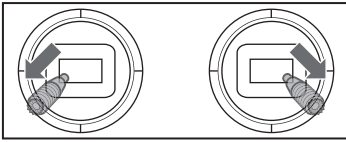

6. When the swashplate servos move, you have entered Servo Adjustment Mode.
7. Release the sticks and proceed to Adjusting the Servo Neutral Position to make any desired changes.

DX7s, DX7 (G2), DX8, DX8 (G2), DX9, DX18 and DX20 Users:

1. Lower the throttle stick to the lowest position.
2. Power ON the transmitter.
3. Install the flight battery on the helicopter frame, securing it with the hook and loop strap.
4. Connect the battery connector to the ESC.
5. Place the helicopter on a flat surface and leave it still until the orange receiver LED glows solid, indicating initialization is complete.
6. Hold the left stick to the bottom left corner and the right stick to the bottom right corner as shown.

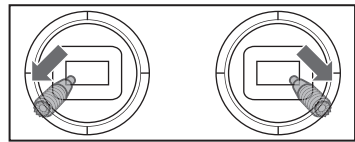

7. Hold the bind/panic switch until the swash servos move.
8. Release the sticks and the bind/panic switch. The model is now in Servo Adjustment Mode.
9. Proceed to Adjusting the Servo Neutral Position to make any desired changes.

Adjusting the Servo Neutral Position

With the model in Servo Adjustment Mode, the control stick and gyro inputs are disabled and the servos are held in the neutral position. Check the position of the servo arms to see if they are perpendicular to the servos.

- If the arms are perpendicular to the servos, no adjustment is necessary.
Exit Servo Adjustment Mode.
- If one or more servo arm is not perpendicular to the servos, continue the servo adjustment process.

While watching the swashplate servos, apply right cyclic and release. One of the servos will jump, indicating which servo is selected. Press right cyclic and release until the servo that needs to be adjusted is selected.

Swashplate Leveling

Before saving your adjustments and exiting servo adjustment mode, verify the swashplate is level and both main rotor blades are at 0 degrees.

If they are not, make linkage adjustments as necessary.

Saving the Servo Adjustments

DX6, DX6e and DX6i Users:

1. Lower the throttle stick to the lowest position and release the sticks.
2. Move the tail rotor stick to the left and hold until the servos move.
3. Release the tail rotor stick to save the servo adjustments.
4. Reconnect the main drive motor to the ESC. Your model is now ready for flight.

Once the servo you wish to adjust is selected, move the cyclic stick forward or backward to adjust the servo neutral position in the desired direction.

If you would like to reset the current servo to the default neutral position, hold the rudder stick full right for 1 second.

The range of adjustment is limited. If you are unable to adjust the servo arm to be perpendicular to the servo, you must reset the servo to the default neutral position, remove the servo arm and place it back onto the servo as close to perpendicular as possible. You may then adjust the servo neutral position using the forward/backward cyclic stick.

DX7s, DX7 (G2), DX8, DX8 (G2), DX9, DX18 and DX20 Users:

1. Lower the throttle stick to the lowest position and release the sticks.
2. Press and hold switch I until the swash servos move.
3. Release switch I to save the servo adjustments.
4. Reconnect the main drive motor to the ESC. Your model is now ready for flight.

All of the settings are stored internally, so your adjustments will be maintained each time you initialize the model.

Blade 180 CFX Troubleshooting Guide

Problem	Possible Cause	Solution
Helicopter will not bind to the transmitter (during binding)	Low flight battery or transmitter battery voltage	Fully charge or replace the flight battery and/or transmitter batteries
	The receiver is not in bind mode	Make sure the bind plug is connected to the receiver bind port extension
	Transmitter is not in bind mode	Refer to your transmitter's instruction manual for binding instructions
	Transmitter too close to the helicopter during the binding process	Power off the transmitter. Move the transmitter to a larger distance from the helicopter. Disconnect and reconnect the flight battery to the helicopter and follow binding instructions
Helicopter will not link to the transmitter (after binding)	Helicopter is bound to a different model memory (ModelMatch™ radios only)	Disconnect the flight battery. Select the correct model memory on the transmitter. Reconnect the flight battery
	Flight battery/Transmitter battery charge is too low	Replace or recharge batteries
The receiver will not initialize	The helicopter was moved during initialization	Lay the helicopter on its side during initialization if windy
	The transmitter is powered off	Power on the transmitter
	Controls are not centered	Center elevator, aileron and rudder controls. Make sure the throttle is at idle
Helicopter will not respond to the throttle but responds to other controls	Throttle not at idle and/or throttle trim is too high	Lower the throttle stick and throttle trim to the lowest settings
	The transmitter flight mode is not in normal mode	Set the flight mode to normal mode
	Throttle hold is on	Make sure throttle hold is off
	The motor is not connected to the ESC or the motor wires are damaged	Connect the motor wires to the ESC and check motor wires for damage
	Flight battery charge is too low	Replace or recharge flight battery
	Throttle channel is reversed	Power down helicopter. Reverse the throttle channel on the transmitter
Helicopter power is lacking	Flight battery has low voltage	Fully charge the flight battery
	Flight battery is old or damaged	Replace the flight battery
	Flight battery cells are unbalanced	Fully charge the flight battery, allowing the charger time to balance the cells
	Excessive current is being drawn through the BEC	Check all servos and the helicopter motor for damage
Helicopter will not lift off	Main rotor head is not spinning in the correct direction	Make sure the main rotor head is spinning clockwise. Refer to motor control test
	Transmitter settings are not correct	Check throttle and pitch curve settings
	Flight battery has low voltage	Fully charge the flight battery
	Main rotor blades are installed backwards	Install the main rotor blades with the thicker side as the leading edge
The helicopter tail spins out of control	Rudder control and/or sensor direction reversed	Make sure the rudder control and the rudder sensor are operating in the correct direction
	Tail servo is damaged	Check the rudder servo for damage and replace if necessary
	Inadequate control arm throw	Check the rudder control arm for adequate travel and adjust if necessary
The helicopter wobbles in flight	Head speed is too low	Increase the helicopter's head speed via your transmitter settings and/or using a freshly charged flight pack
	Dampers are worn	Replace the main rotor head dampers

Exploded View

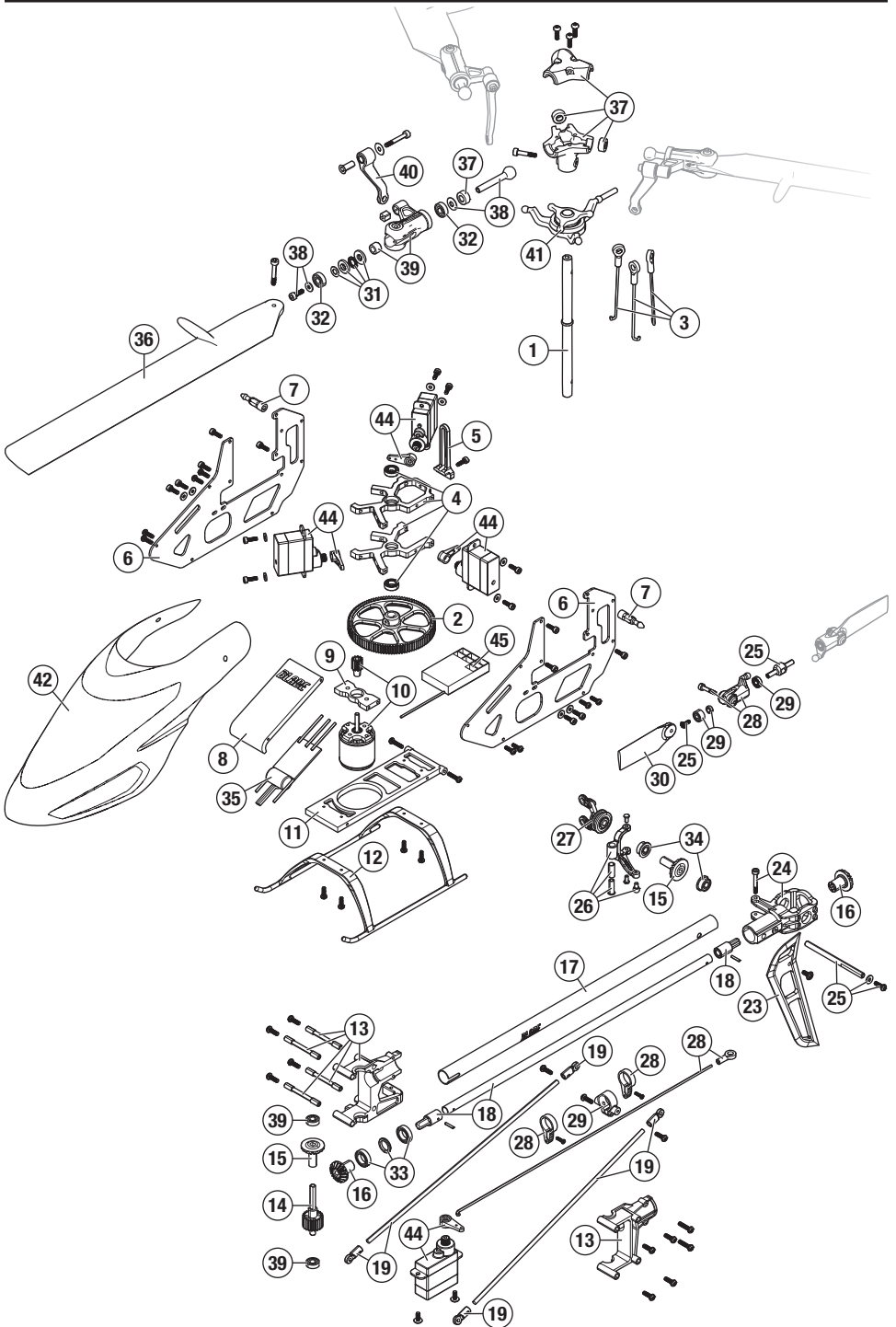

Replacement Parts

#	Part #	Description
1	BLH3407	Main Shaft Set: 180 CFX
2	BLH3408	Main Gear: 180 CFX
3	BLH3410	Servo Control Linkage Set: 180 CFX
4	BLH3411	Main Bearing Block Set: 180 CFX
5	BLH3412	Anti-Rotation Bracket: 180 CFX
6	BLH3413	Carbon Fiber Main Frame: 180 CFX
7	BLH3414	Body Post Set: 180 CFX
8	BLH3415	Battery Tray: 180 CFX
9	BLH3416	Motor Mount: 180 CFX
10	BLH3417	Brushless Main Motor: 180 CFX
11	BLH3418	Bottom Plate: 180 CFX
12	BLH3419	Landing Gear: 180 CFX
13	BLH3420	Front Tail Boom Case: 180 CFX
14	BLH3421	Tail Pinion Gear/Shaft: 180 CFX
15	BLH3422	Bevel Gear: 180 CFX
16	BLH3423	Torque Tube Gear: 180 CFX
17	BLH3424	Tail Boom (2): 180 CFX
18	BLH3425	Torque Tube (2): 180 CFX
19	BLH3426	Boom Support Set: 180 CFX
20	BLH3427	Tail Pushrod (2): 180 CFX
21	BLH3428	Tail Pushrod Guide Set: 180 CFX
22	BLH3429	Tail Boom Clamp: 180 CFX
23	BLH3430	Vertical Fin: 180 CFX

#	Part #	Description
24	BLH3431	Tail Case Set: 180 CFX
25	BLH3432	Tail Shaft and Hub: 180 CFX
26	BLH3433	Tail Pitch Bellcrank: 180 CFX
27	BLH3434	Tail Pitch Slider: 180 CFX
28	BLH3435	Tail Grip Set: 180 CFX
29	BLH3436	Tail Grip Bearing Set: 180 CFX
30	BLH3437	Tail Blade Set: 180 CFX
31	BLH3438	2.5x6x2.8mm Thrust Bearing: 180 CFX
32	BLH3439	2.5x6x1.8mm Radial Bearing: 180 CFX
33	BLH3440	5x8x2mm Radial Bearing: 180 CFX
34	BLH3441	2.5x6x2.6 Flanged Bearing: 180 CFX
35	BLH3442	Castle Creations 15A Blade ESC
36	BLH3751	150mm Main Blades (3): Trio 180 CFX
37	BLH3752	3-Blade Head Block: Trio 180 CFX
38	BLH3753	Feathering Spindle Set (3): Trio 180 CFX
39	BLH3754	Main Blade Grips (3): Trio 180 CFX
40	BLH3755	Flybarless Follower Arms (3): Trio 180 CFX
41	BLH3756	Swashplate: Trio 180 CFX
42	BLH3758	Stock Canopy: Trio 180 CFX
43	EFLRDS76TJ	7.6g Sub-Micro Digital Tail Servo JST
44	SPMSH2065	7.6g Sub-Micro Digital Metal Gear Servo JST
45	BLH3759	Blade Replacement Receiver: Trio 180

Optional Parts

Part #	Description
EFLB4503SJ30	450mAh 3S 11.1V 30C LiPo, 18AWG JST
BLH3402C	Carbon Fiber Main Blades: 180 CFX
BLH3409	Stock Canopy: 180 CFX
BLH3409A	Option Canopy: 180 CFX
BLH3431A	Aluminum Tail Case Set: 180 CFX
BLH3433A	Aluminum Tail Pitch Bellcrank: 180 CFX
BLH3434A	Tail Pitch Slider Aluminum: 180 CFX
DYNC2005	Prophet Sport Li-Po 35W AC Charger

Part #	Description
	DX6i DSMX 6-Channel Transmitter Only
	DX6 DSMX 6-Channel Transmitter Only
	DX7s DSMX 7-Channel Transmitter Only
	DX8 DSMX 8-Channel Transmitter Only
	DX9 DSMX 9-Channel Transmitter Only
	DX18 DSMX 18-Channel Transmitter Only
	DX20 DSMX 20-Channel Transmitter Only

Limited Warranty

What This Warranty Covers

Horizon Hobby, LLC, (Horizon) warrants to the original purchaser that the product purchased (the "Product") will be free from defects in materials and workmanship at the date of purchase.

What is Not Covered

This warranty is not transferable and does not cover (i) cosmetic damage, (ii) damage due to acts of God, accident, misuse, abuse, negligence, commercial use, or due to improper use, installation, operation or maintenance, (iii) modification of or to any part of the Product, (iv) attempted service by anyone other than a Horizon Hobby authorized service center, (v) Product not purchased from an authorized Horizon dealer, (vi) Product not compliant with applicable technical regulations, or (vii) use that violates any applicable laws, rules, or regulations.

OTHER THAN THE EXPRESS WARRANTY ABOVE, HORIZON MAKES NO OTHER WARRANTY OR REPRESENTATION, AND HEREBY DISCLAIMS ANY AND ALL IMPLIED WARRANTIES, INCLUDING, WITHOUT LIMITATION, THE IMPLIED WARRANTIES OF NON-INFRINGEMENT, MERCHANTABILITY AND FITNESS FOR A PARTICULAR PURPOSE. THE PURCHASER ACKNOWLEDGES THAT THEY ALONE HAVE DETERMINED THAT THE PRODUCT WILL SUITABLY MEET THE REQUIREMENTS OF THE PURCHASER'S INTENDED USE.

Purchaser's Remedy

Horizon's sole obligation and purchaser's sole and exclusive remedy shall be that Horizon will, at its option, either (i) service, or (ii) replace, any Product determined by Horizon to be defective. Horizon reserves the right to inspect any

and all Product(s) involved in a warranty claim. Service or replacement decisions are at the sole discretion of Horizon. Proof of purchase is required for all warranty claims. SERVICE OR REPLACEMENT AS PROVIDED UNDER THIS WARRANTY IS THE PURCHASER'S SOLE AND EXCLUSIVE REMEDY.

Limitation of Liability

HORIZON SHALL NOT BE LIABLE FOR SPECIAL, INDIRECT, INCIDENTAL OR CONSEQUENTIAL DAMAGES, LOSS OF PROFITS OR PRODUCTION OR COMMERCIAL LOSS IN ANY WAY, REGARDLESS OF WHETHER SUCH CLAIM IS BASED IN CONTRACT, WARRANTY, TORT, NEGLIGENCE, STRICT LIABILITY OR ANY OTHER THEORY OF LIABILITY, EVEN IF HORIZON HAS BEEN ADVISED OF THE POSSIBILITY OF SUCH DAMAGES. Further, in no event shall the liability of Horizon exceed the individual price of the Product on which liability is asserted. As Horizon has no control over use, setup, final assembly, modification or misuse, no liability shall be assumed nor accepted for any resulting damage or injury. By the act of use, setup or assembly, the user accepts all resulting liability. If you as the purchaser or user are not prepared to accept the liability associated with the use of the Product, purchaser is advised to return the Product immediately in new and unused condition to the place of purchase.

Law

These terms are governed by Illinois law (without regard to conflict of law principals). This warranty gives you specific legal rights, and you may also have other rights which vary from state to state. Horizon reserves the right to change or modify this warranty at any time without notice.

WARRANTY SERVICES

Questions, Assistance, and Services

Your local hobby store and/or place of purchase cannot provide warranty support or service. Once assembly, setup or use of the Product has been started, you must contact your local distributor or Horizon directly. This will enable Horizon to better answer your questions and service you in the event that you may need any assistance. For questions or assistance, please visit our website at www.horizonhobby.com, submit a Product Support Inquiry, or call the toll free telephone number referenced in the Warranty and Service Contact Information section to speak with a Product Support representative.

Inspection or Services

If this Product needs to be inspected or serviced and is compliant in the country you live and use the Product in, please use the Horizon Online Service Request submission process found on our website or call Horizon to obtain a Return Merchandise Authorization (RMA) number. Pack the Product securely using a shipping carton. Please note that original boxes may be included, but are not designed to

withstand the rigors of shipping without additional protection. Ship via a carrier that provides tracking and insurance for lost or damaged parcels, as Horizon is not responsible for merchandise until it arrives and is accepted at our facility. An Online Service Request is available at http://www.horizonhobby.com/content/_service-center_render-service-center. If you do not have internet access, please contact Horizon Product Support to obtain a RMA number along with instructions for submitting your product for service. When calling Horizon, you will be asked to provide your complete name, street address, email address and phone number where you can be reached during business hours. When sending product into Horizon, please include your RMA number, a list of the included items, and a brief summary of the problem. A copy of your original sales receipt must be included for warranty consideration. Be sure your name, address, and RMA number are clearly written on the outside of the shipping carton.

NOTICE: Do not ship Li-Po batteries to Horizon. If you have any issue with a Li-Po battery, please contact the appropriate Horizon Product Support office.

Warranty Requirements

For Warranty consideration, you must include your original sales receipt verifying the proof-of-purchase date. Provided warranty conditions have been met, your Product will be serviced or replaced free of charge. Service or replacement decisions are at the sole discretion of Horizon.

Non-Warranty Service

Should your service not be covered by warranty, service will be completed and payment will be required without notification or estimate of the expense unless the expense exceeds 50% of the retail purchase cost. By submitting the item for service you are agreeing to payment of the service without notification. Service estimates are available upon request. You must include this request with your item submitted for service. Non-warranty service estimates will be billed a minimum of ½ hour of labor. In addition you will be billed for return freight. Horizon accepts money orders and cashier's checks, as well as Visa, MasterCard, American Express, and Discover cards. By submitting any item to Horizon for service, you are agreeing to Horizon's Terms and Conditions found on our website http://www.horizonhobby.com/content/_service-center_render-service-center.

ATTENTION: Horizon service is limited to Product compliant in the country of use and ownership. If received, a non-compliant Product will not be serviced. Further, the sender will be responsible for arranging return shipment of the un-serviced Product, through a carrier of the sender's choice and at the sender's expense. Horizon will hold non-compliant Product for a period of 60 days from notification, after which it will be discarded. 10/15

Warranty and Service Contact Information

Country of Purchase	Horizon Hobby	Contact Information	Address
United States of America	Horizon Service Center (Repairs and Repair Requests)	servicecenter.horizonhobby.com/ RequestForm/	4105 Fieldstone Rd Champaign, Illinois, 61822 USA
	Horizon Product Support (Product Technical Assistance)	productsupport@horizonhobby.com 877-504-0233	
	Sales	websales@horizonhobby.com 800-338-4639	
European Union	Horizon Technischer Service	service@horizonhobby.de	Hanskampring 9 D 22885 Barsbüttel, Germany
	Sales: Horizon Hobby GmbH	+49 (0) 4121 2655 100	

FCC Information

This equipment has been tested and found to comply with the limits for Part 15 of the FCC rules. These limits are designed to provide reasonable protection against harmful interference in a residential installation. This equipment generates uses and can radiate radio frequency energy and, if not installed and used in accordance with the instructions, may cause harmful interference to radio communications. However, there is no guarantee that interference will not occur in a particular installation. If this equipment does cause harmful interference to radio or television reception, which can be determined by turning the equipment off and on, the user is encouraged to try to correct the interference by one or more of the following measures:

- Reorient or relocate the receiving antenna.
- Increase the separation between the equipment and receiver.
- Connect the equipment to an outlet on a circuit different from that to which the receiver is connected.

This device complies with part 15 of the FCC rules. Operation is subject to the following two conditions: (1) This device may not cause harmful interference, and (2) this device must accept any interference received, including interference that may cause undesired operation.

NOTICE: Modifications to this product will void the user's authority to operate this equipment.

IC Information

This device complies with Industry Canada licence-exempt RSS standard(s). Operation is subject to the following two conditions:

- (1) this device may not cause interference, and (2) this device must accept any interference, including interference that may cause undesired operation of the device."

Compliance Information for the European Union



EU Compliance Statement: BLH3750

Horizon Hobby, LLC hereby declares that this product is in compliance with the essential requirements and other relevant provisions of the RED Directive.

A copy of the EU Declaration of Conformity is available online at:
<http://www.horizonhobby.com/content/support-render-compliance>.

Instructions for disposal of WEEE by users in the European Union



This product must not be disposed of with other waste. Instead, it is the user's responsibility to dispose of their waste equipment by handing it over to a designated collections point for the recycling of waste electrical and electronic equipment. The separate collection and recycling of your waste equipment at the time of disposal will help to conserve natural resources and make sure that it is recycled in a manner that protects human health and the environment. For more information about where you can drop off your waste equipment for recycling, please contact your local city office, your household waste disposal service or where you purchased the product.



©2017 Horizon Hobby, LLC.

Blade, E-flite, Prophet, AS3X, DSM, DSM2, DSMX, AirWare, ModelMatch, BNF, the BNF logo and the Horizon Hobby logo are trademarks or registered trademarks of Horizon Hobby, LLC. The Spektrum trademark is used with permission of Bachmann Industries, Inc.

All other trademarks, service marks or logos are property of their respective owners.

Patents pending.

Created 11/16

51452

BLH3750