

# **RC8** :: *Instruction Manual*

**80900: RC8 Factory Built**  
**80905: RC8 Ready-To-Run (RTR)**



**:: For RC8 FT Factory Built  
start on page 34.**

## **1/8th Scale Nitro Powered 4WD Racing Buggy**

**:: Introduction**

Thank you for purchasing this Team Associated product. This manual contains instructions and tips for building and maintaining your new RC8. Please take a moment to read through it and familiarize yourself with these steps. For the Factory Team Factory Built RC8, please start on Page 34.

**:: RC8 Features****:: Factory Team**

- Nyloc wheel nuts
- Factory Blue titanium turnbuckles
- True-Lock kingpin system
- Heavy duty CVA's with captured pins
- Factory Team threaded, hard-coated shock bodies with 4mm gold shock shafts and rubber boots
- Factory Team 4mm low-profile woven carbon fiber shock towers
- Woven carbon fiber steering rack
- Woven carbon fiber radio tray
- Sealed radio box
- Thread-through antenna mount
- Durable 10mm thick suspension arms
- Rubber CVA boots
- Fully adjustable pre-drilled screw mounted wing
- Strong anti-wobble wheels
- Anti-foaming fuel tank
- Low-profile, elliptical, high-flow two-stage air filter

**:: Ready-To-Run**

- Aluminum wheel nuts
- Tough, steel turnbuckles
- True-Lock kingpin system
- Heavy duty CVA's with captured pins
- Hard coated shock bodies with 4mm shock shafts and rubber boots
- Durable, molded radio tray & antenna mount
- Sealed radio box
- 3mm aluminum front/rear shock towers
- Durable 10mm thick suspension arms
- Rubber CVA boots
- Fully adjustable pre-drilled screw mounted wing
- Strong anti-wobble wheels
- Anti-foaming fuel tank
- Low-profile, elliptical, high-flow two-stage air filter

**:: Additional****:: Factory Team**

Your RC8 Buggy comes assembled with all the Factory Team hopups installed. However, there are some items you will need to complete your kit:

- .21 Class Rear Exhaust Engine
- 2 Channel Radio Set - FM/PCM recommended.
- 4.8v-6.0v Receiver Battery Pack (RC8 will accept either flat or hump pack, AE Part #614 Flat, 615 Hump)
- Muffler, Joining Pack or Manifold & Spring
- AA-Size Batteries for Transmitter
- Model Car Fuel (30% Nitro recommended)
- Fuel Bottle (AE Part #1749)
- Glow Starter (AE Part #1738)
- Starter Box (AE Part #1750)
- 1/8th Scale Buggy Tires
- Cyanoacrylic glue (AE Part #1597)
- Thread Locking Compound (AE Pt#1596)
- Silicone Shock Fluid (Refer to Parts List)
- Lexan Specific Spray Paint
- Lexan Scissors (AE Pt#1737)
- Reamer/Hole Punch
- Hex Wrenches (AE Part #1541)
- Hobby Knife
- Needle Nose Pliers
- Wire Cutters

**:: Ready-To-Run**

Your RC8 RTR Buggy comes factory assembled including radio gear. However, there are some items you will need to complete your kit:

- AA-Size Batteries for Transmitter (x8)
- AA-Size Batteries for the onboard electronics (x4) (or a 4.8v-6.0v Receiver Battery Pack, 3x2 pack recommended, AE Part #614 Flat, 615 Hump)
- D-Size Battery for Glow Starter (x1)
- 6-Cell Sub-C Size Battery Pack for Pro-Start Starting Gun
- Charger for Battery Pack
- Model Car Fuel (20%-30% Nitro recommended)



## :: Front and Rear Differentials

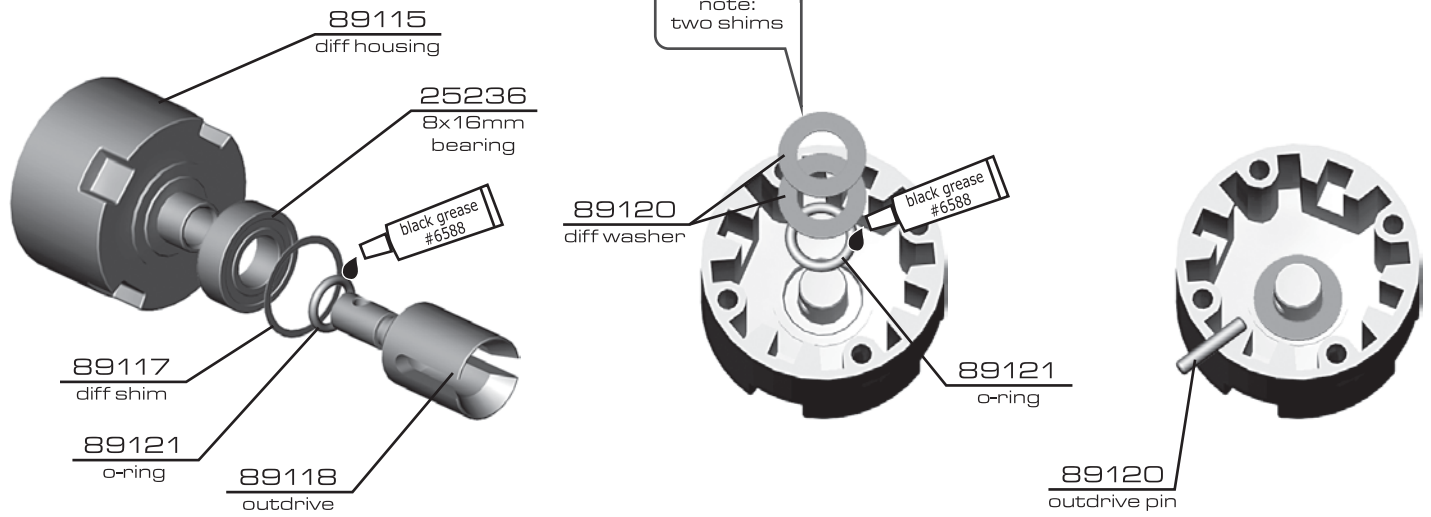

## :: Front and Rear Differentials (cont.)



## :: Front and Rear Differentials (cont.)

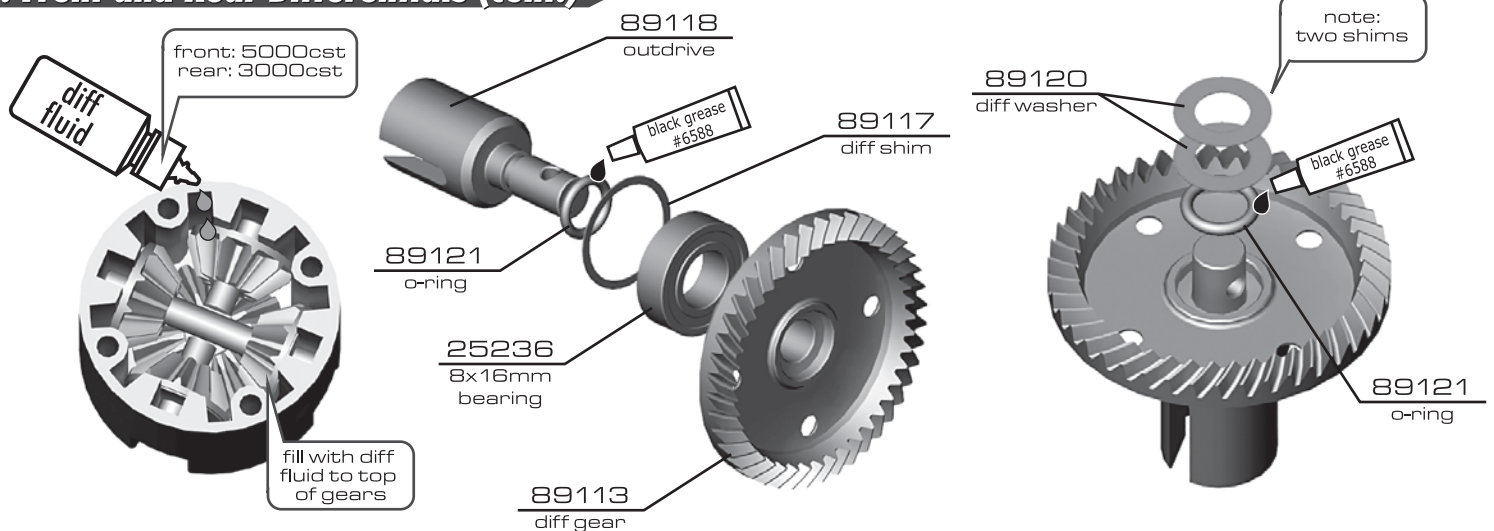



## :: Front and Rear Differentials (cont.)

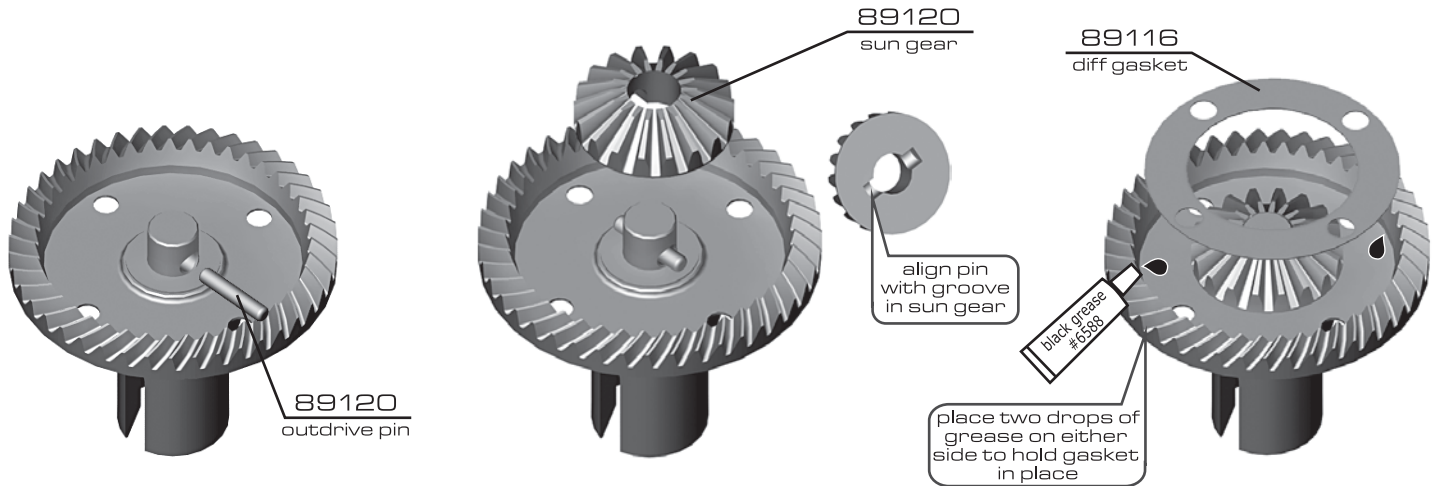

## :: Front and Rear Differentials (cont.)

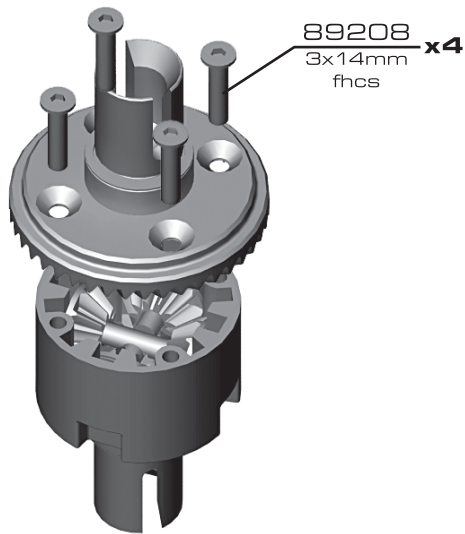

## :: Center Differential

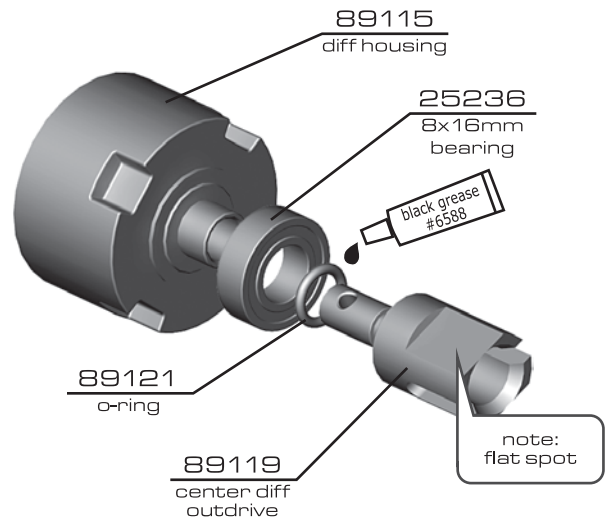

## :: Center Differential (cont.)





## :: Center Differential (cont.)



89120 spider gear assembly

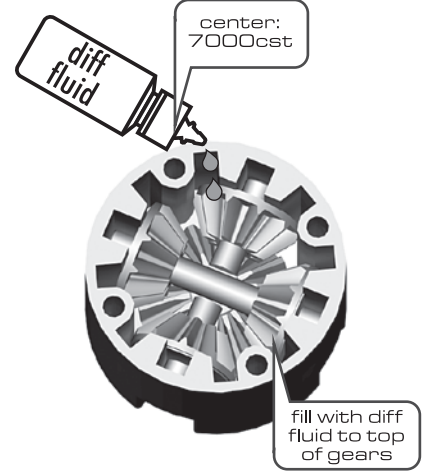
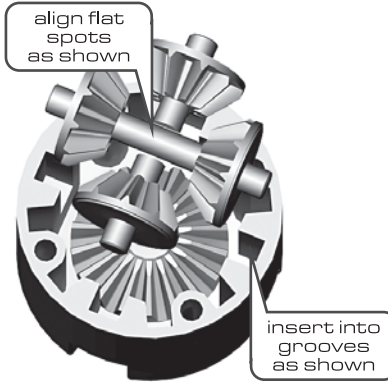

## :: Center Differential (cont.)

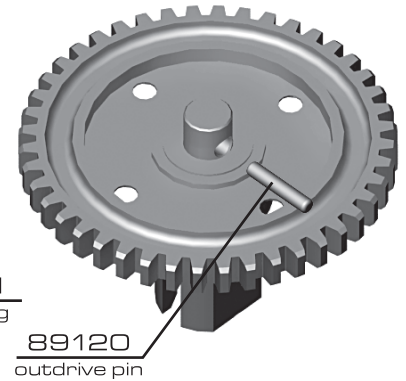
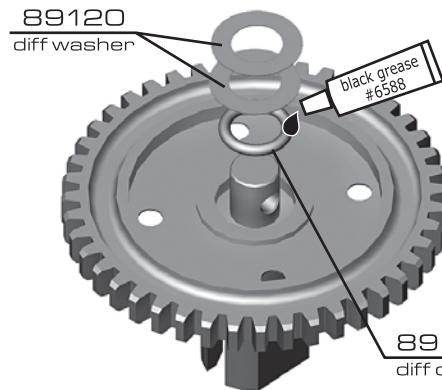
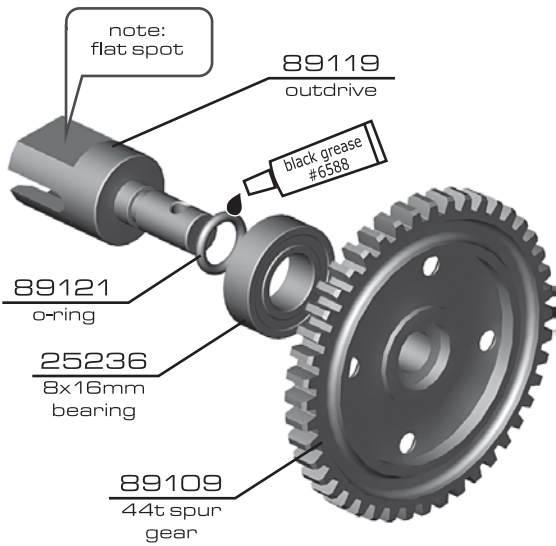

## :: Center Differential (cont.)

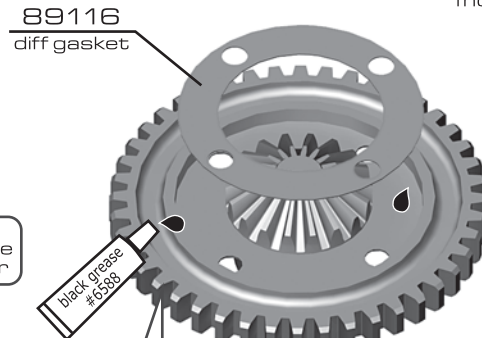
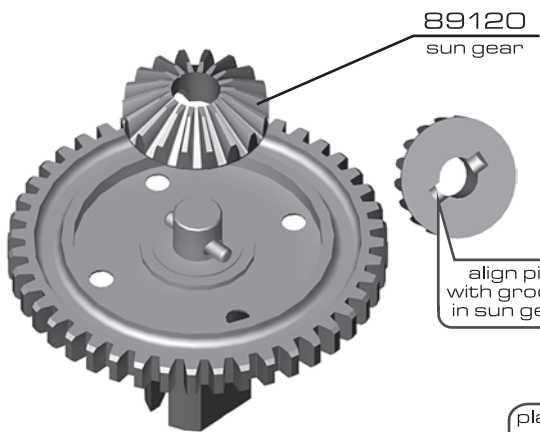

place two drops of grease on either side to hold gasket in place

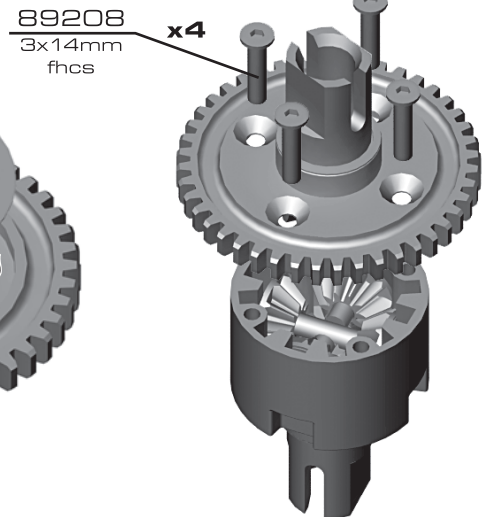

**:: Chassis Braces**

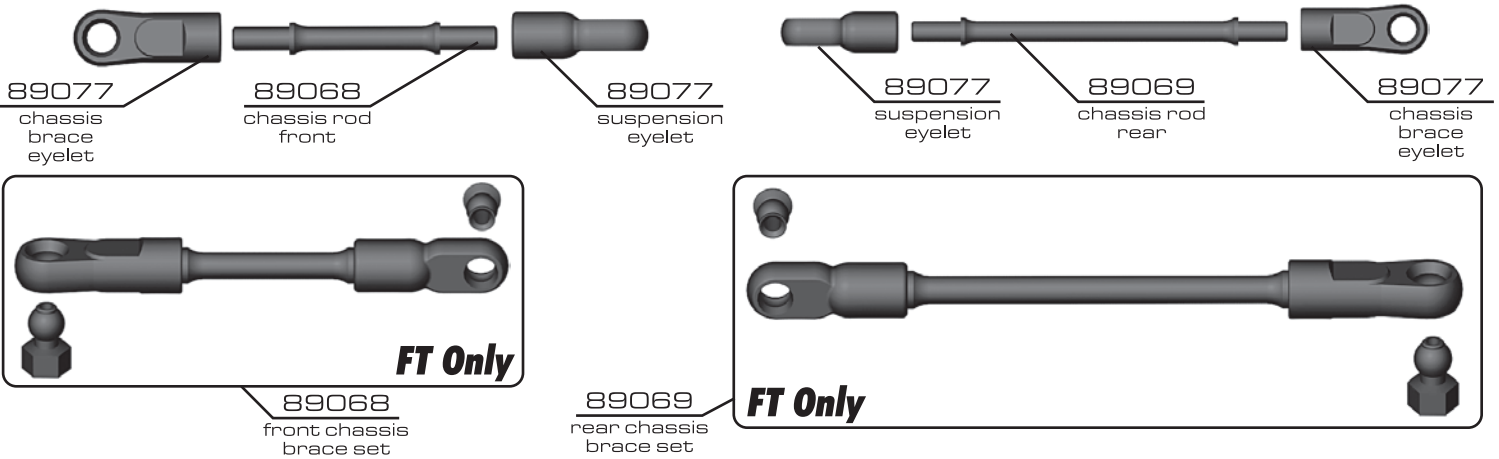

**:: Steering Turnbuckles**

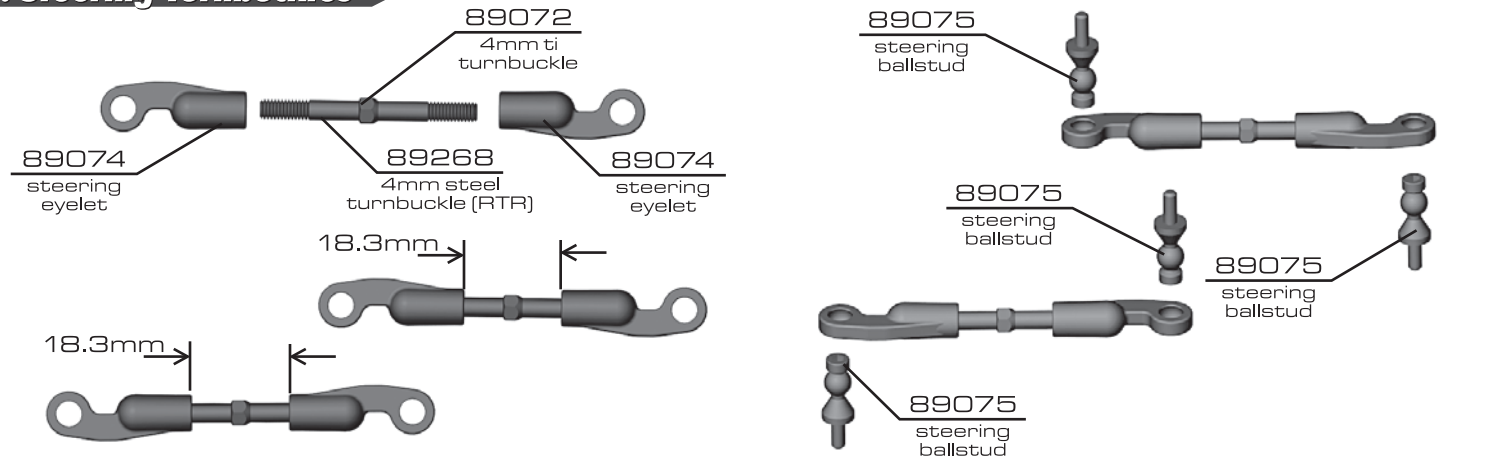

**:: Servo Turnbuckle**



**:: Camber Turnbuckles**

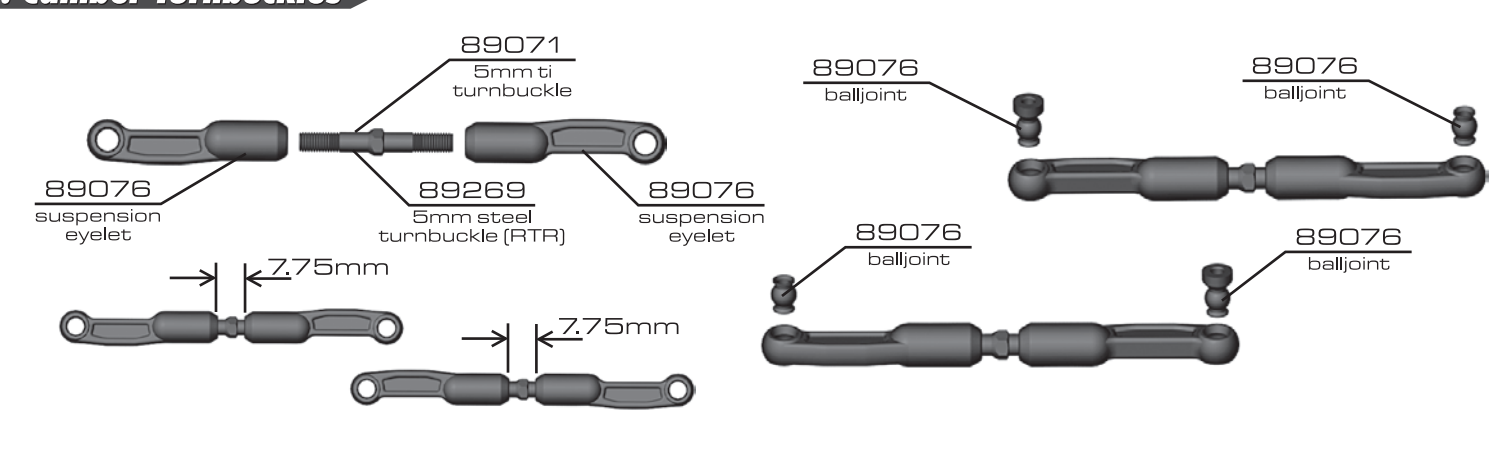

## :: Shocks

FT threaded shown

- 89215 piston locknut
- 1.6mm shock piston
- 89055 shock piston set (1.4, 1.5, 1.6mm)
- 89260 shock shaft front (RTR)
- 89053 shock shaft gold, front (FT)
- 89054 shock shaft gold, rear (FT)
- 89261 shock shaft rear (RTR)
- 89052 shock body front (FT)
- 89051 shock body rear (FT)
- 89263 shock body front (RTR)
- 89264 shock body rear (RTR)
- 89066 shock o-rings
- 89064 shock rebuild kit

shock fluid

1 drop on threads

## :: Shocks (cont.)

- 89058 shock boot front
- 89059 shock boot rear
- fit boot into groove
- tighten eyelet to line on shaft
- 89065 shock rod eyelet
- 89065 shock rod eyelet ball
- 89063 shock bladder

shock fluid

fill to top with shock oil  
front: 50wt #5432  
rear: 40wt #5423

## :: Shocks (cont.)

### Bladder installation

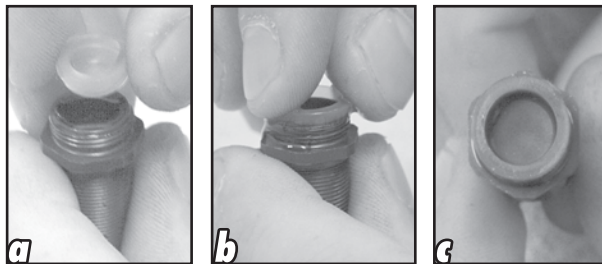

With the shaft fully extended, place bladder onto the top of the shock body (a), displacing the extra fluid (b). Make sure there are no air bubbles under the bladder (c). If there are, gently lift one side of the bladder to allow air bubbles to escape.

- 89061 shock cap retainer
- 89061 shock cap
- 89262 molded shock cap
- 89057 threaded shock collar o-ring
- 89057 threaded shock collar

shock fluid

1 drop

RTR



**:: Shocks (cont.)**

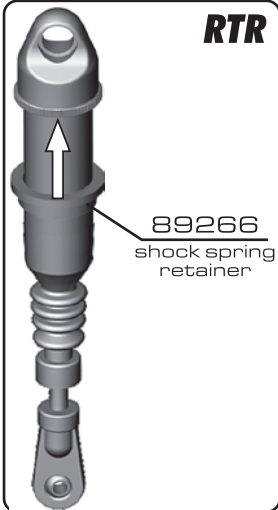

**RTR**

**89266**  
shock spring  
retainer

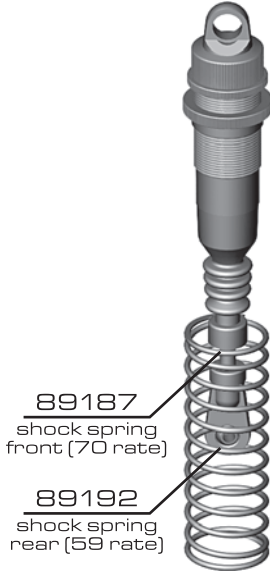

**89187**  
shock spring  
front (70 rate)

**89192**  
shock spring  
rear (59 rate)

front: 5.3mm  
rear: 6.4mm

-slide boot over  
shock eyelet  
  
-install spring  
cup over boot  
and eyelet

**89062**  
spring cup

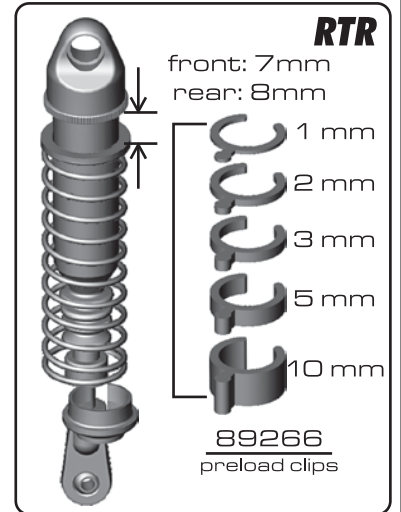

**RTR**

front: 7mm  
rear: 8mm

1 mm  
2 mm  
3 mm  
5 mm  
10 mm

**89266**  
preload clips

**:: Steering**

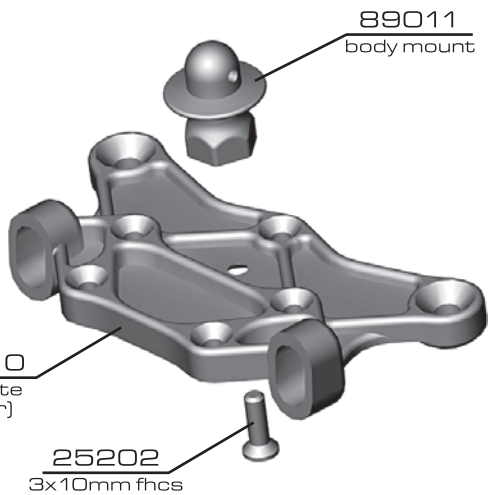

**89011**  
body mount

**89010**  
top plate  
(upper)

**25202**  
3x10mm fhcs

**89039**  
hinge pin  
bushing  
(1 dot)

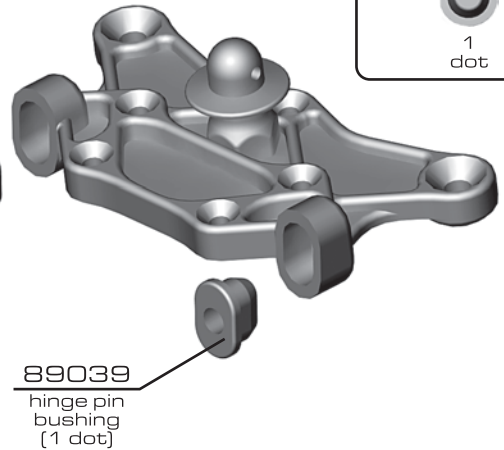

**89039**  
hinge pin  
bushing  
(1 dot)

hinge pin bushings



1  
dot

**:: Steering (cont.)**

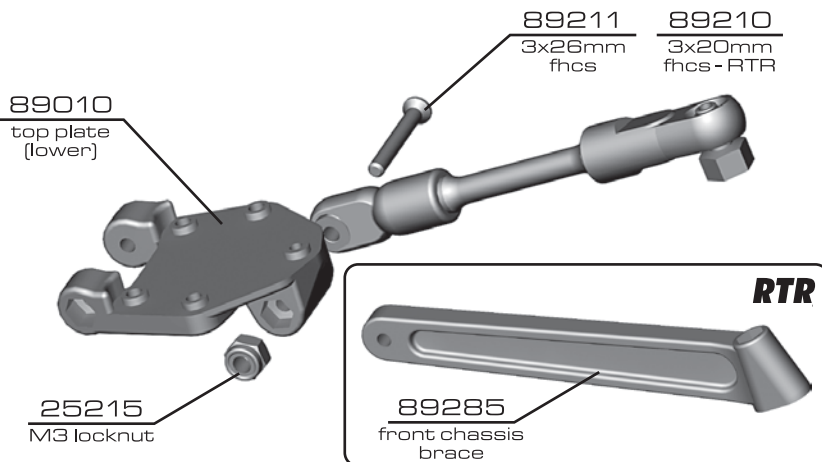

**89010**  
top plate  
(lower)

**25215**  
M3 locknut

**89211**  
3x26mm  
fhcs

**89210**  
3x20mm  
fhcs -RTR

**RTR**

**89285**  
front chassis  
brace

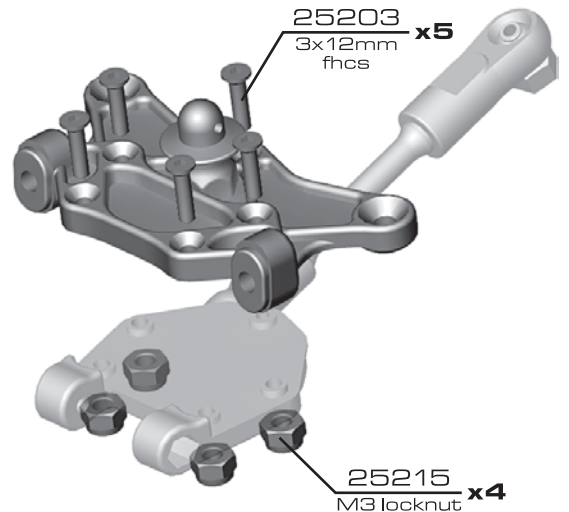

**25203**  
3x12mm  
fhcs **x5**

**25215**  
M3 locknut **x4**

## :: Steering (cont.)

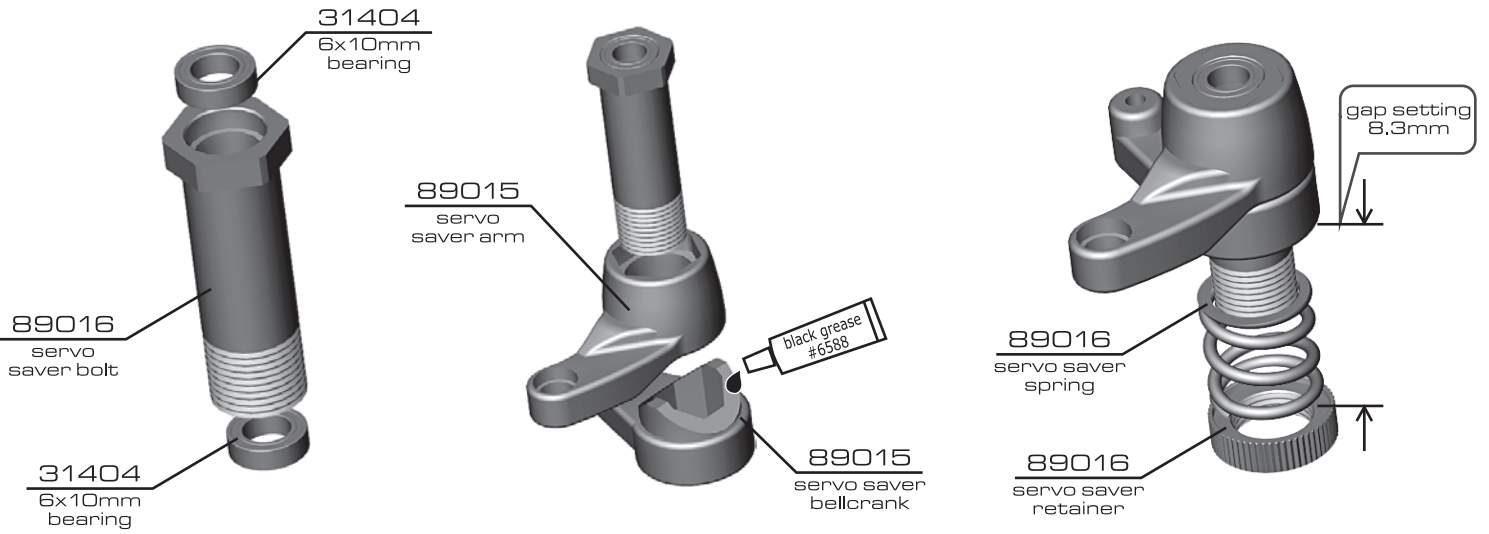

## :: Steering (cont.)

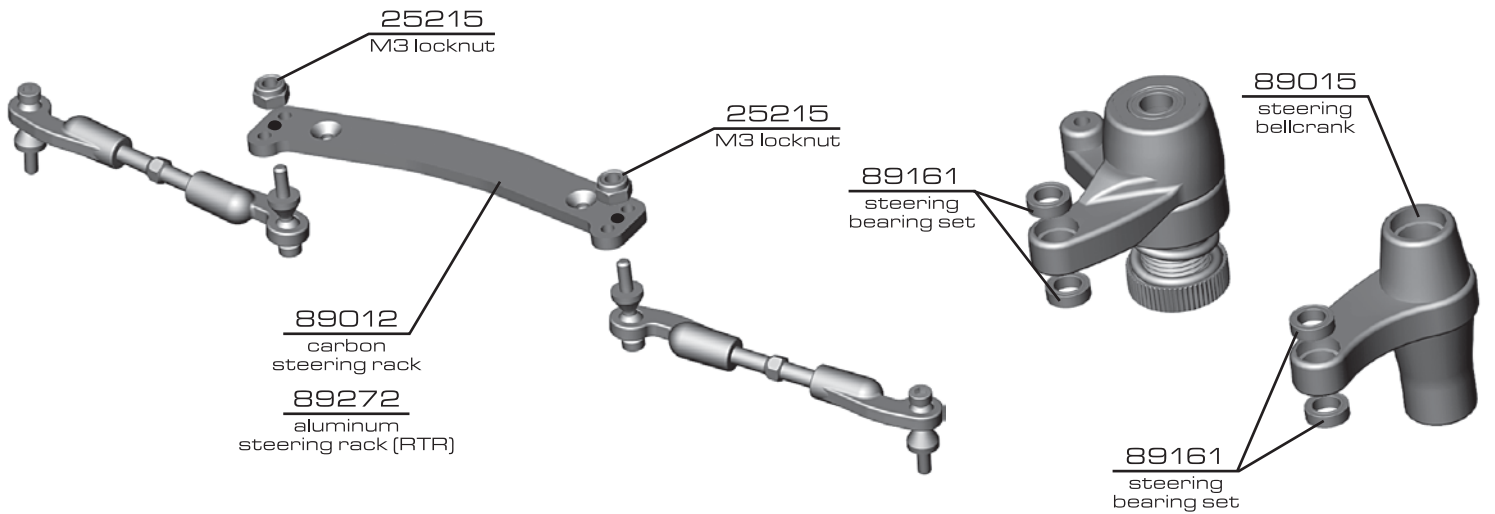

## :: Steering (cont.)

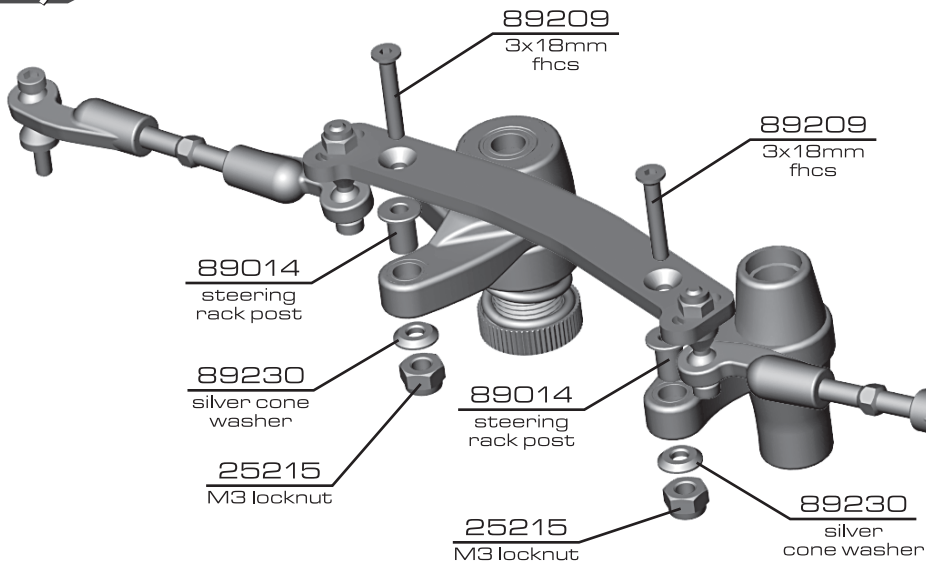

**:: Steering (cont.)**

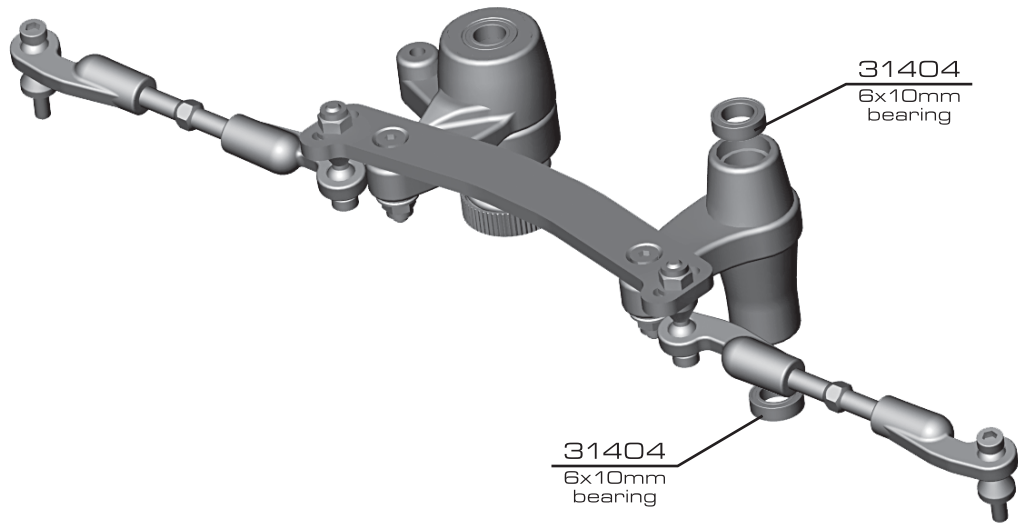

**:: Steering (cont.)**

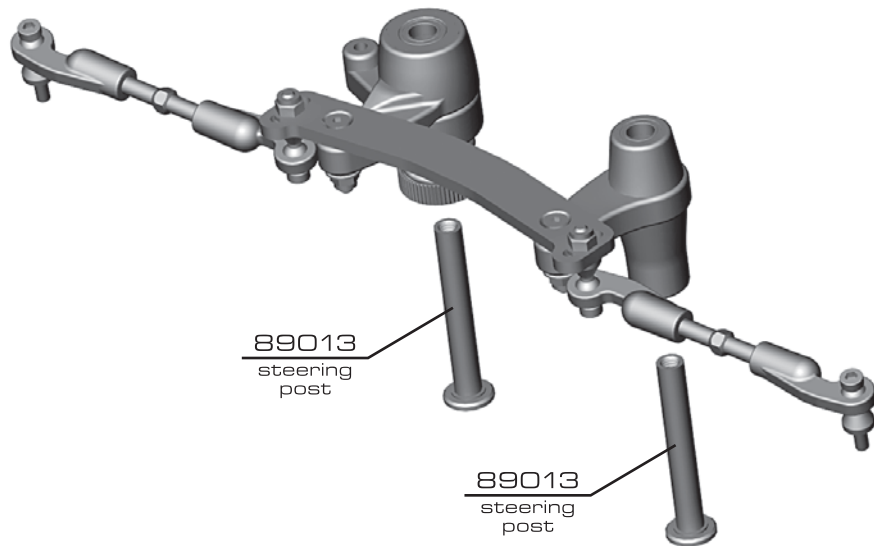

**:: Steering (cont.)**

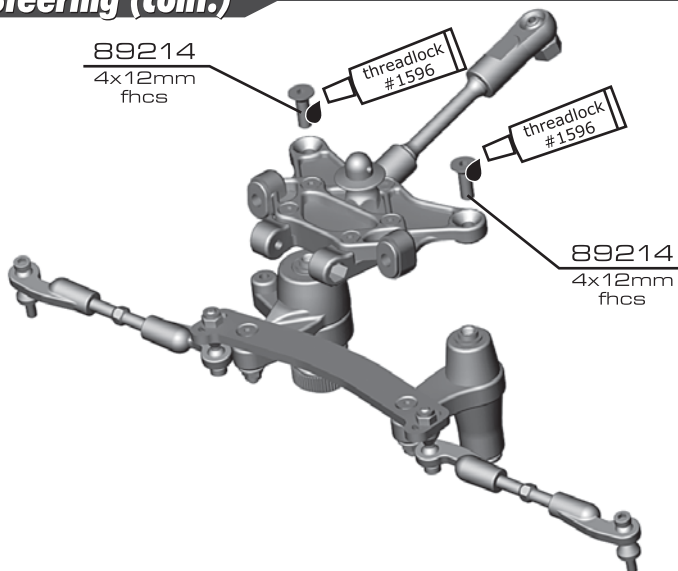

**:: Front Gearbox**

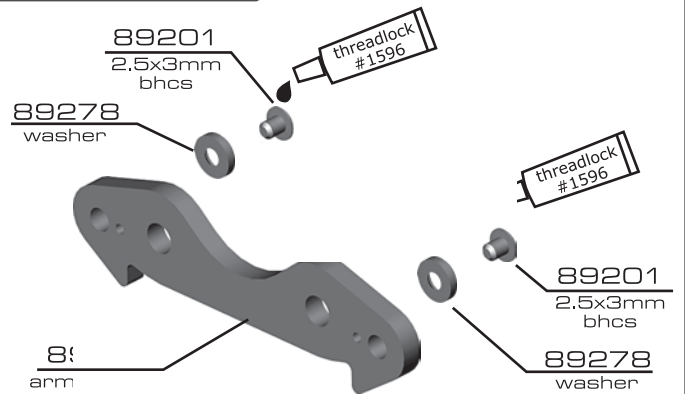



## :: Front Gearbox (cont.)

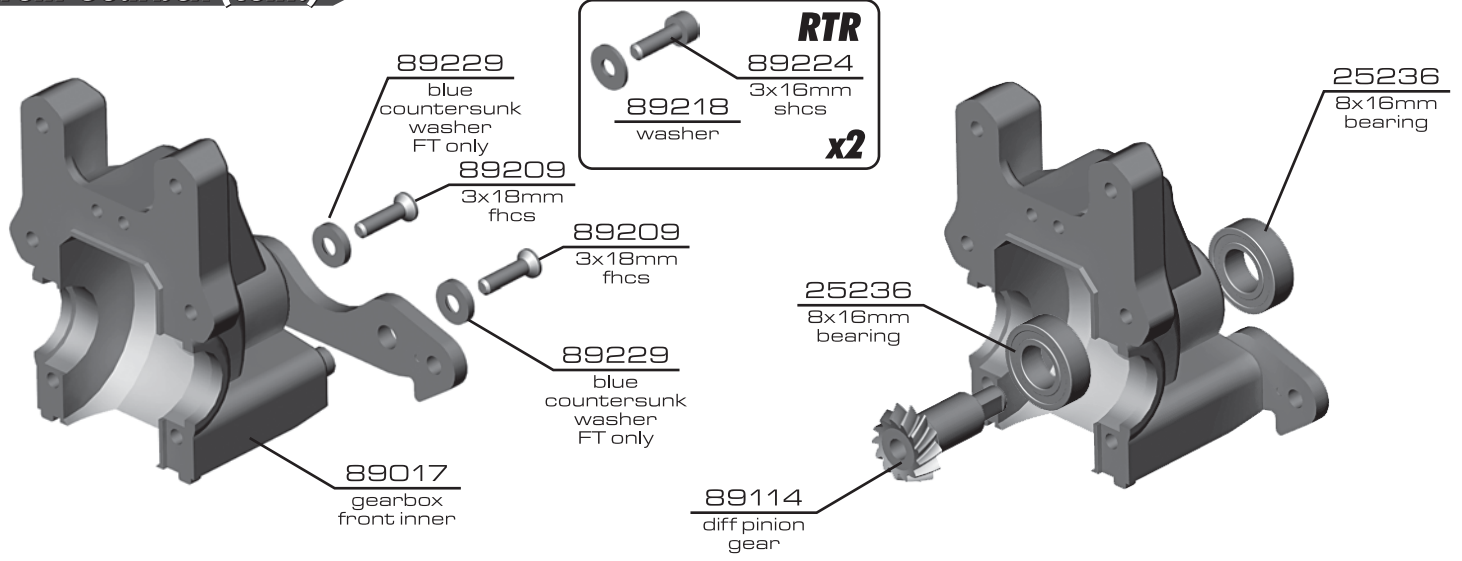

## :: Front Gearbox (cont.)

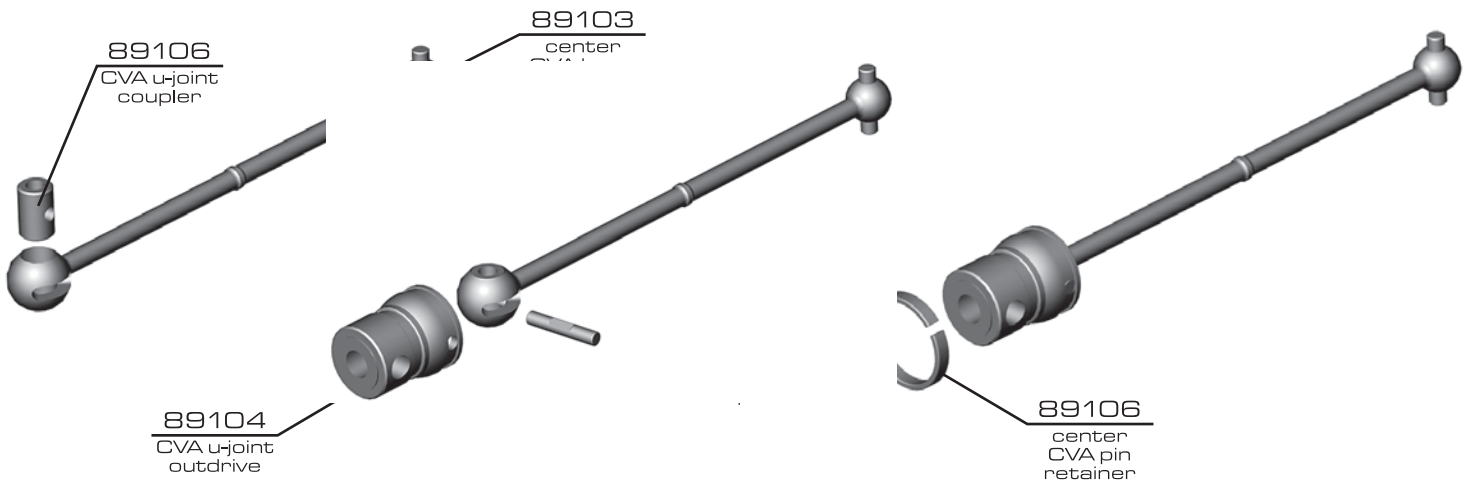

## :: Front Gearbox (cont.)

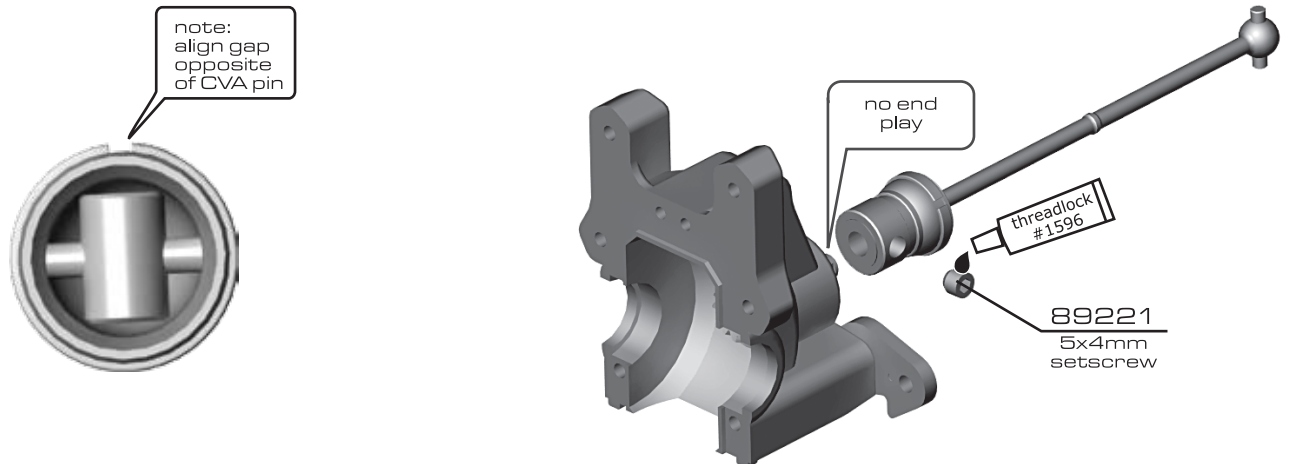

:: Front Gearbox (cont.)

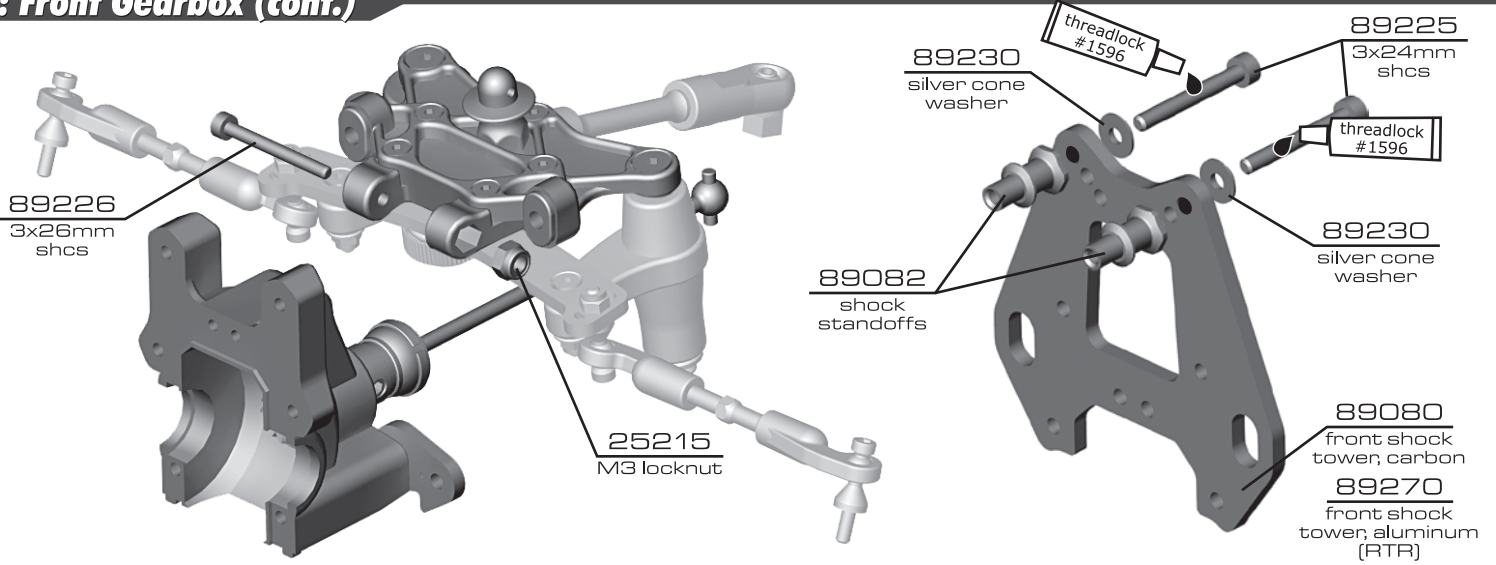

:: Front Gearbox (cont.)

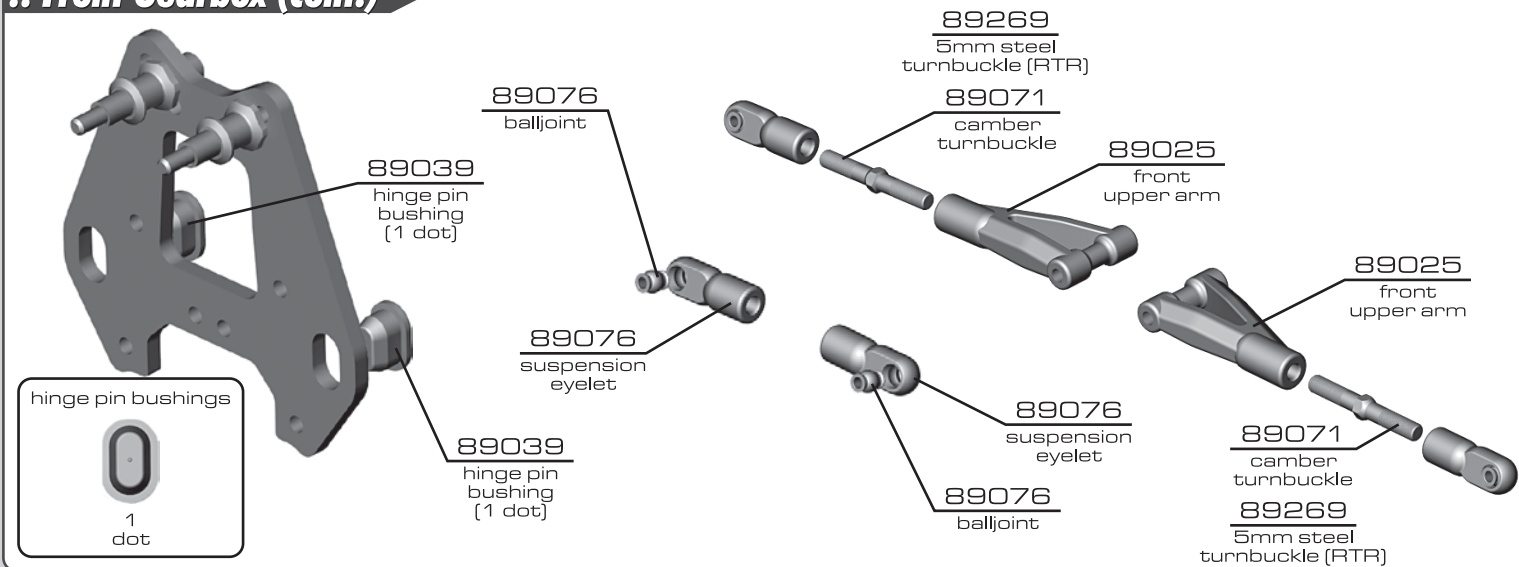

:: Front Gearbox (cont.)

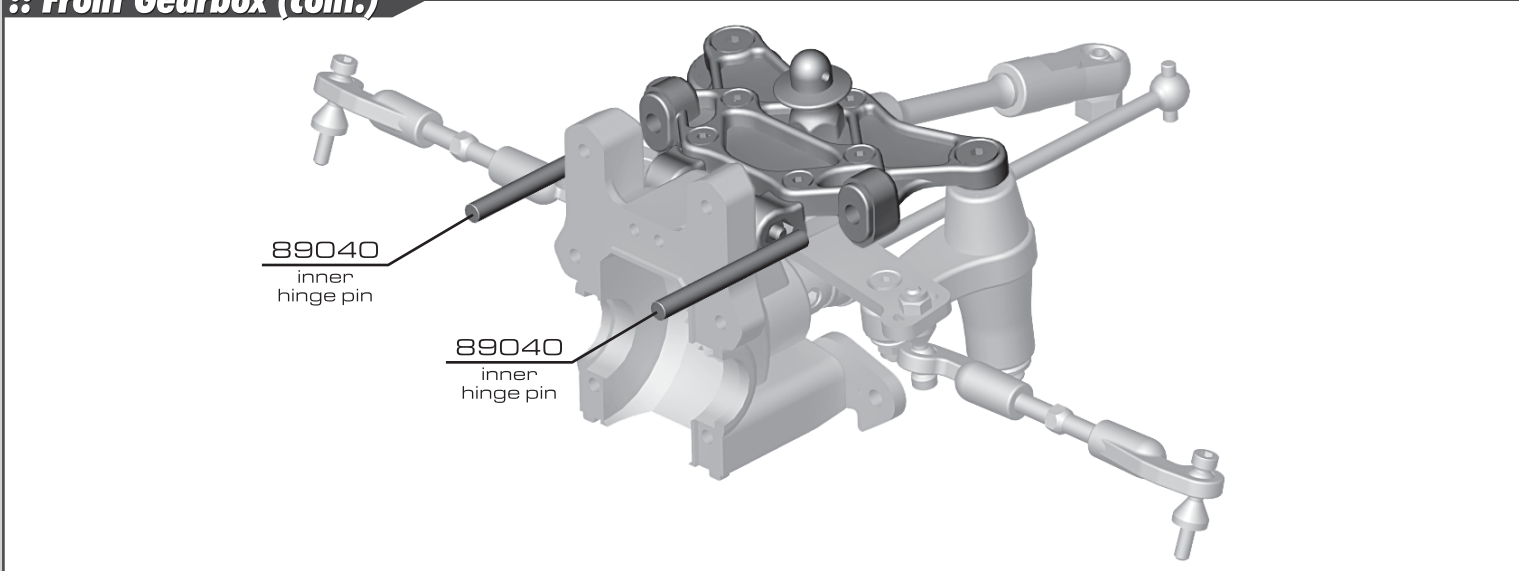

## :: Front Gearbox (cont.)

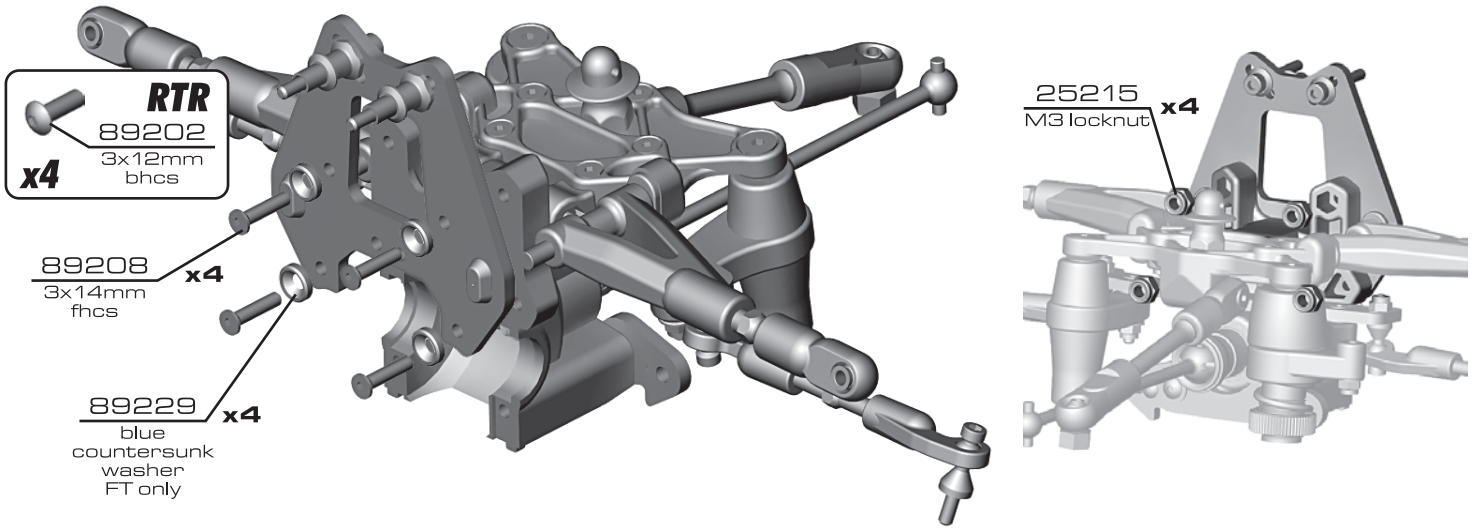

## :: Front Gearbox (cont.)

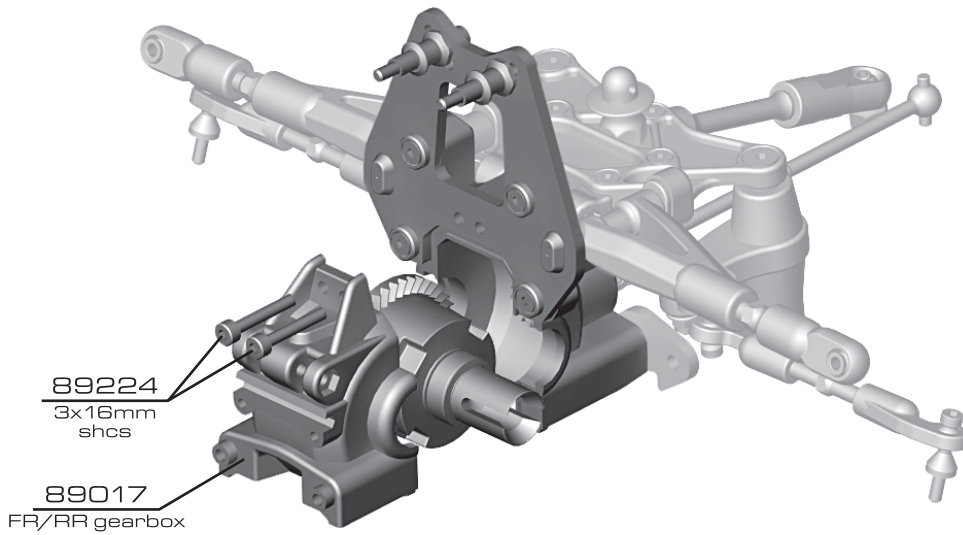

## :: Front Gearbox (cont.)

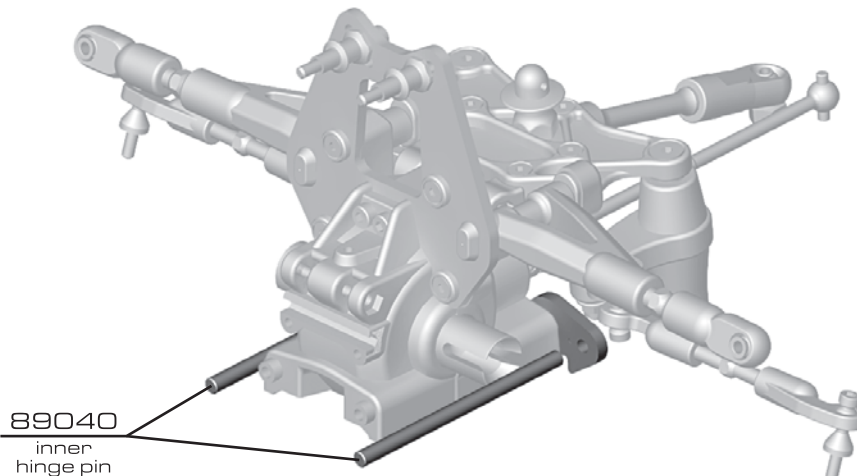



:: Suspension

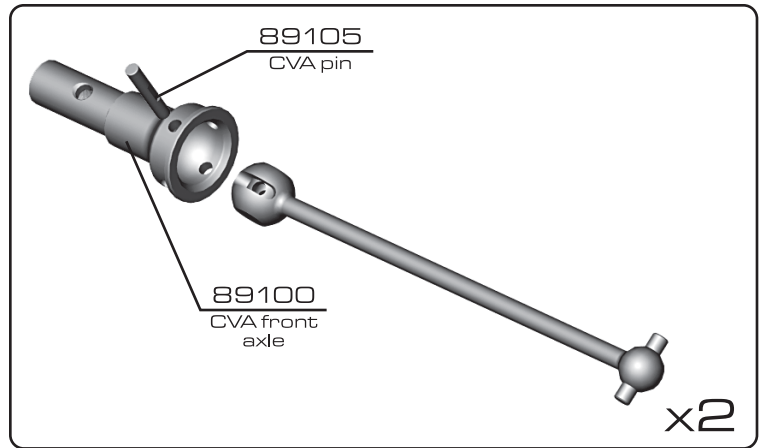
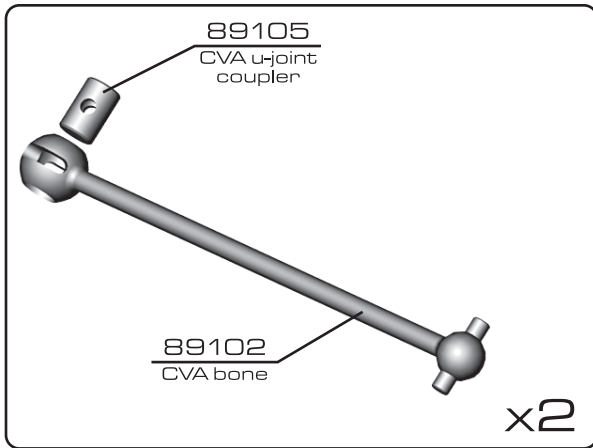

:: Suspension (cont.)

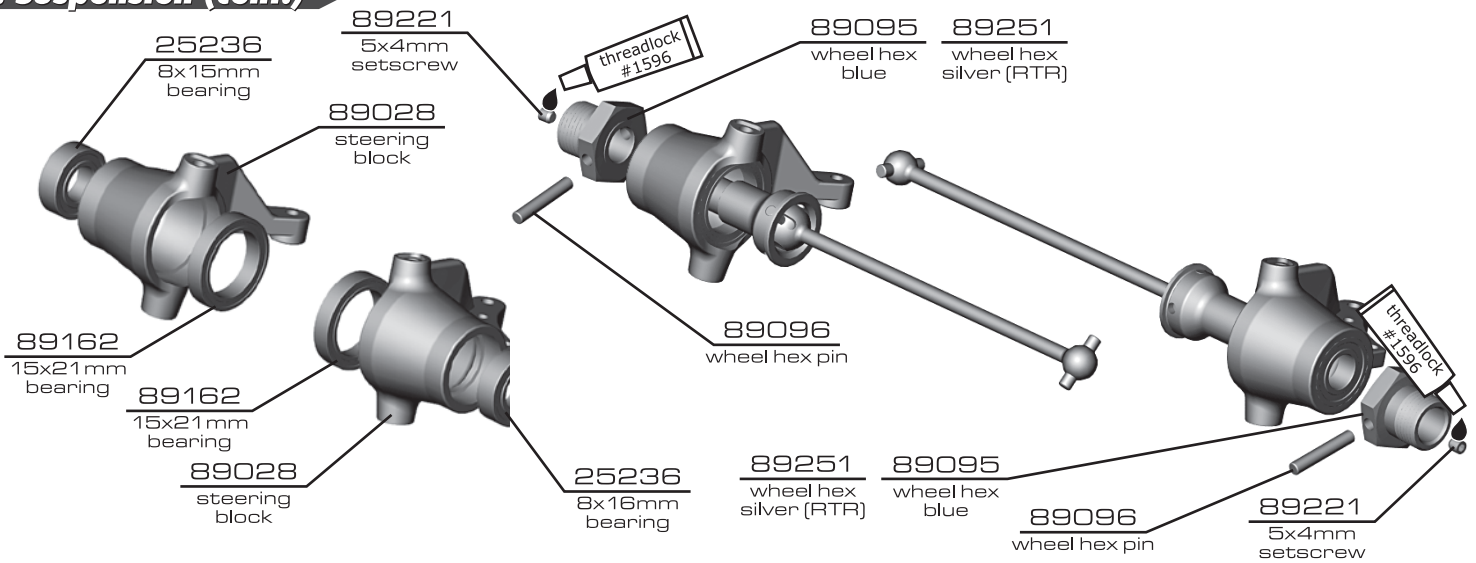

:: Suspension (cont.)

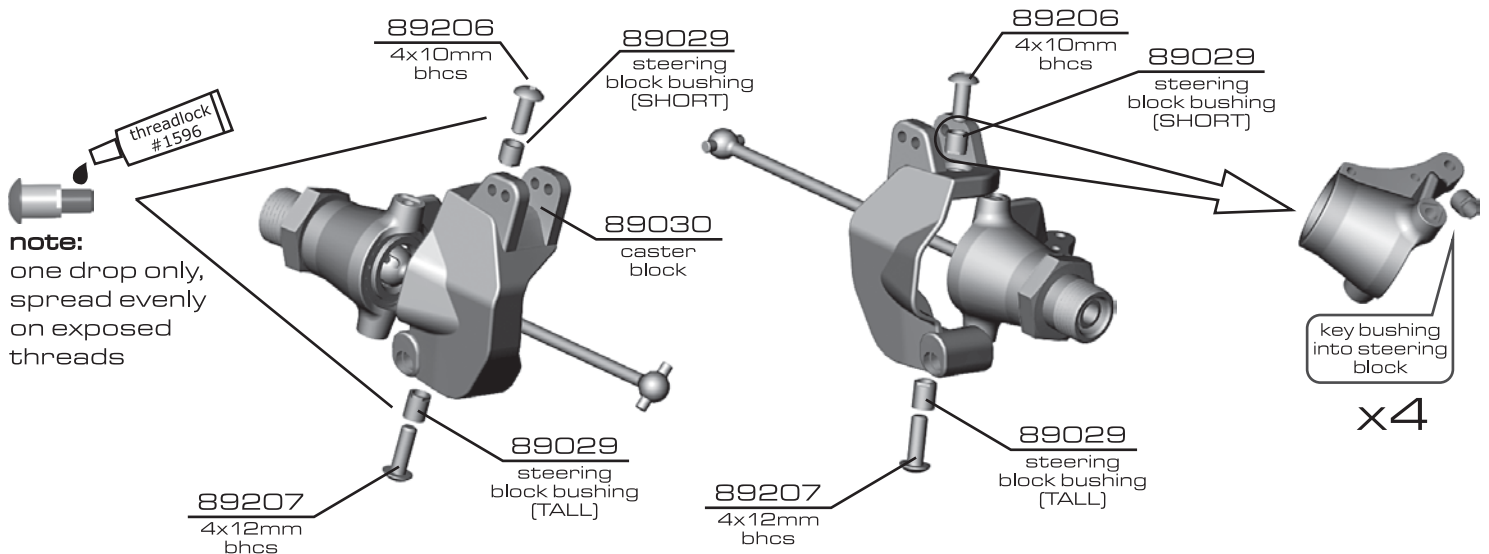

## :: Suspension (cont.)

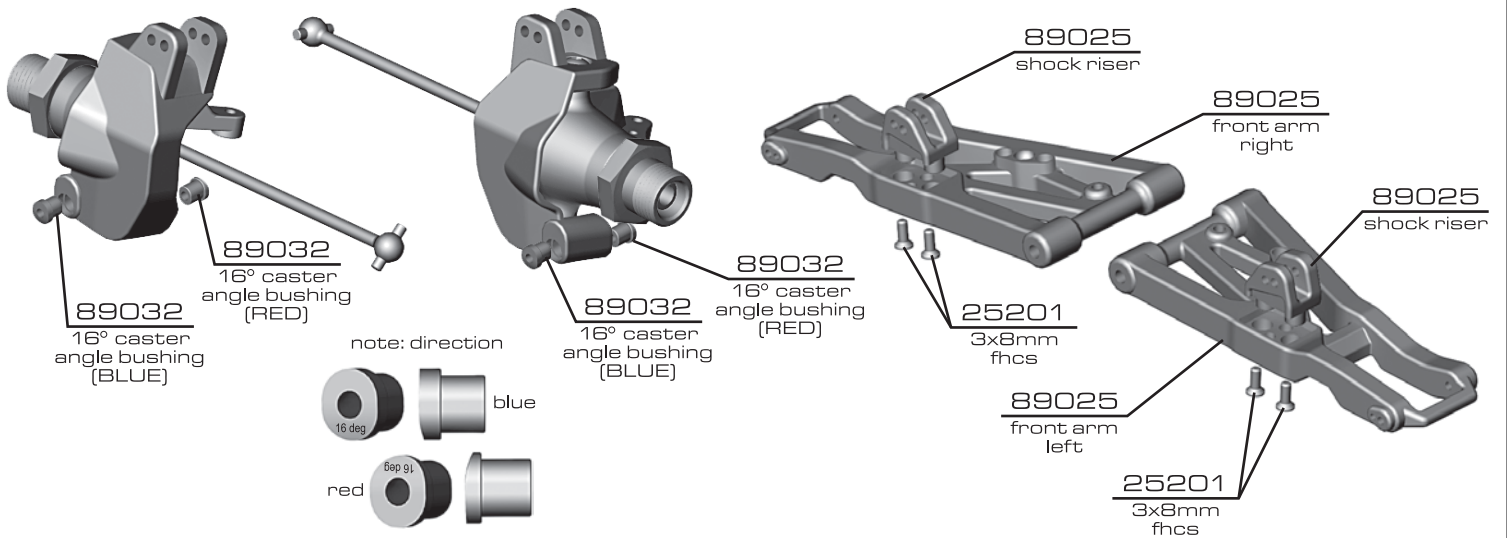

## :: Suspension (cont.)

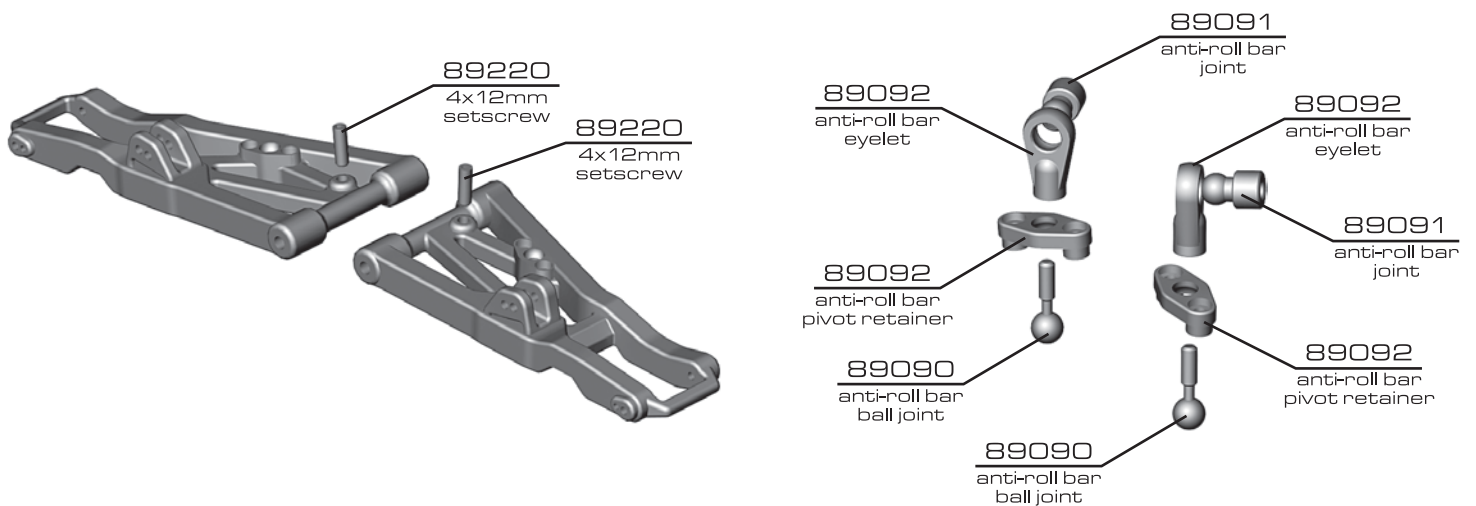

## :: Suspension (cont.)

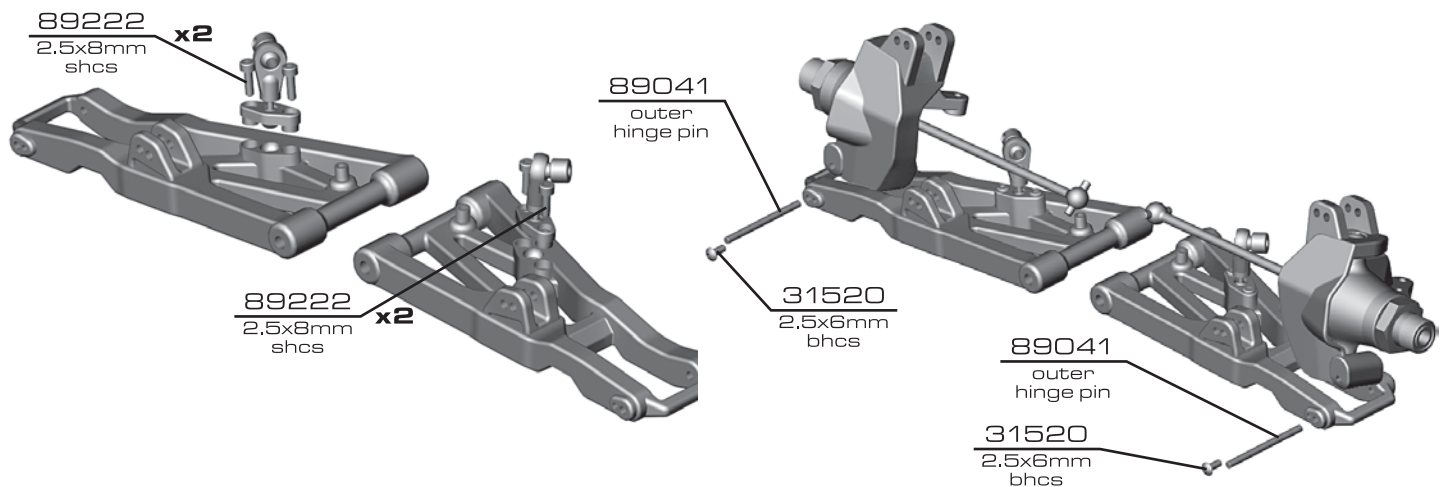

:: Suspension (cont.)

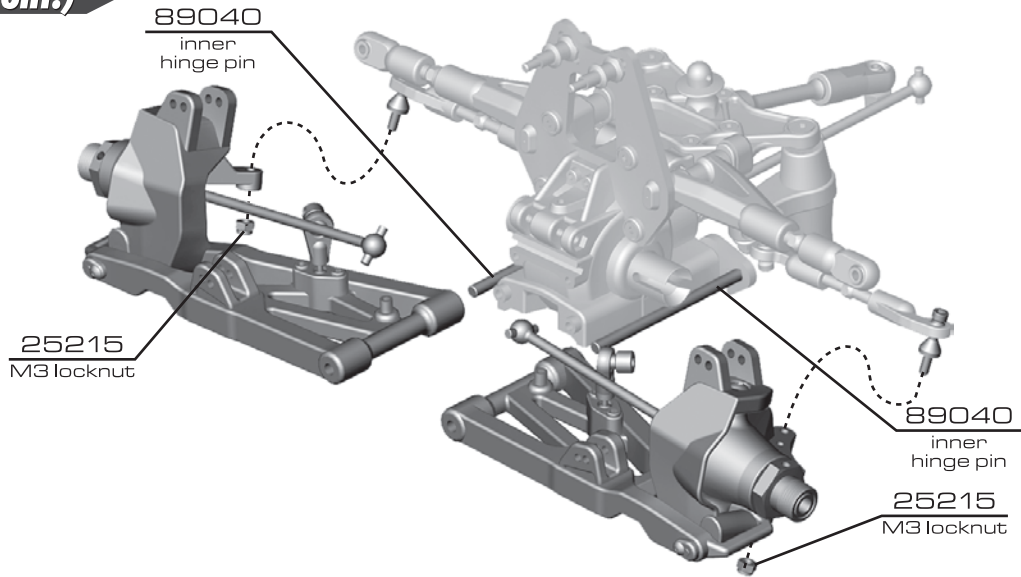

:: Suspension (cont.)

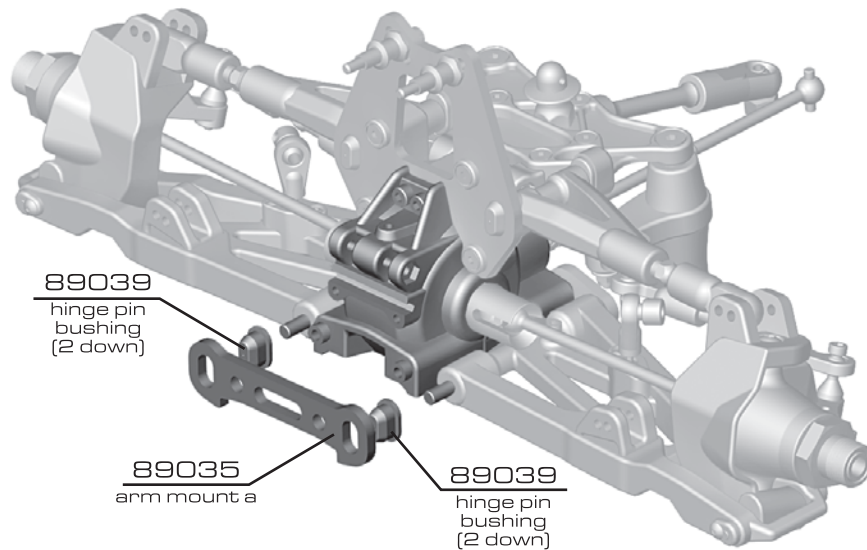

hinge pin bushings



2  
down

:: Suspension (cont.)

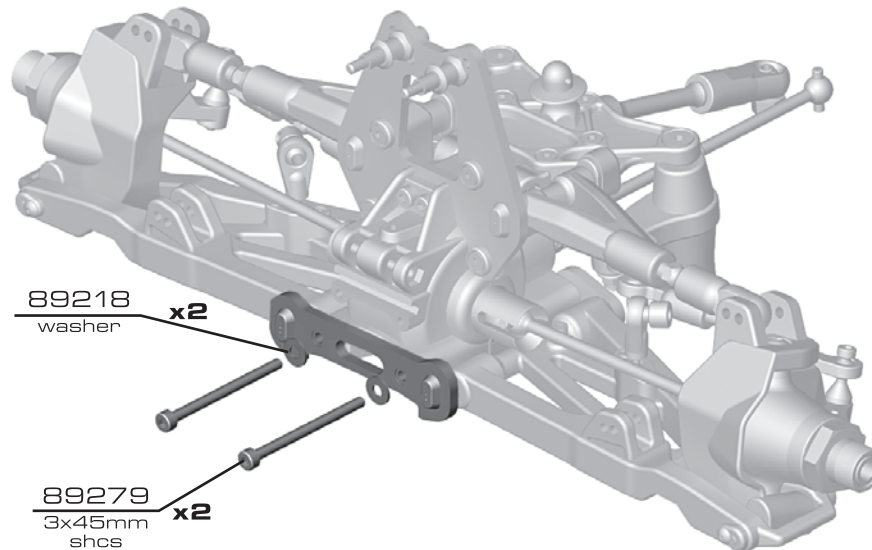



## :: Suspension (cont.)

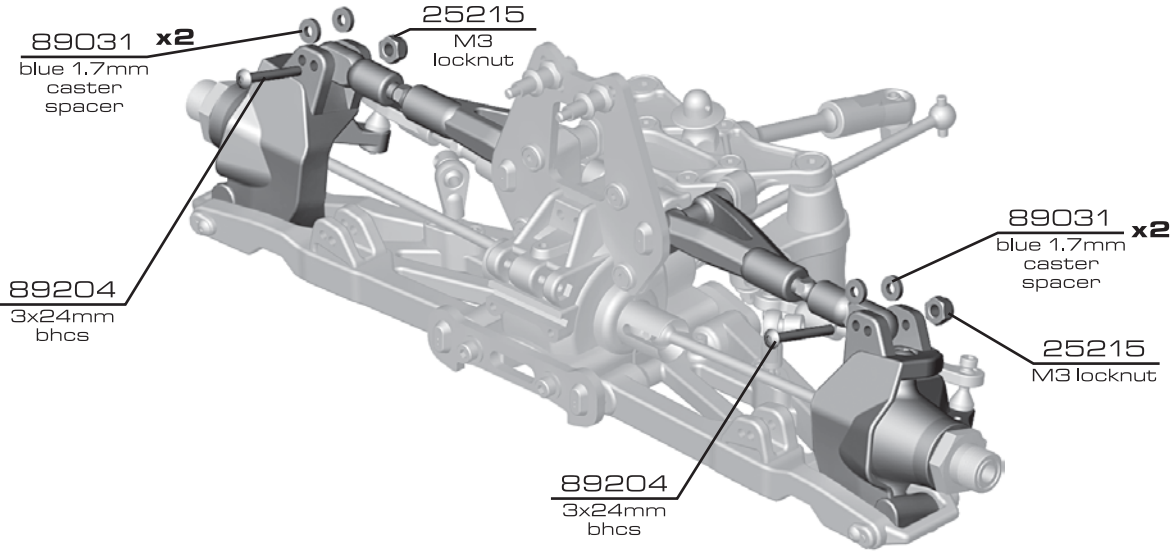

## :: Suspension (cont.)

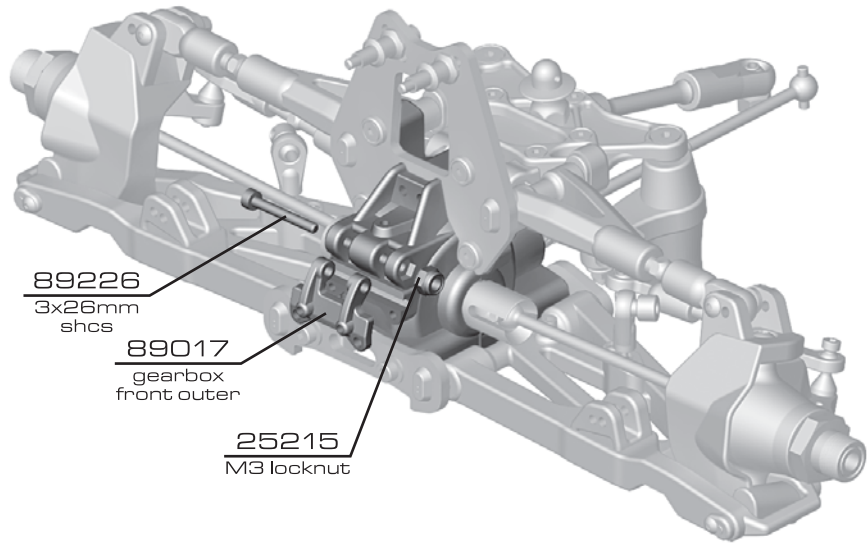

## :: Suspension (cont.)

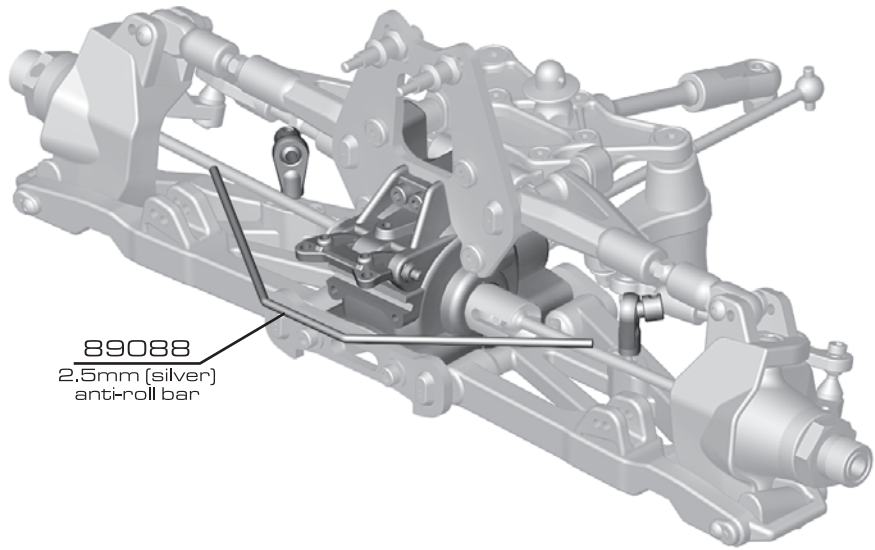

**:: Suspension (cont.)**

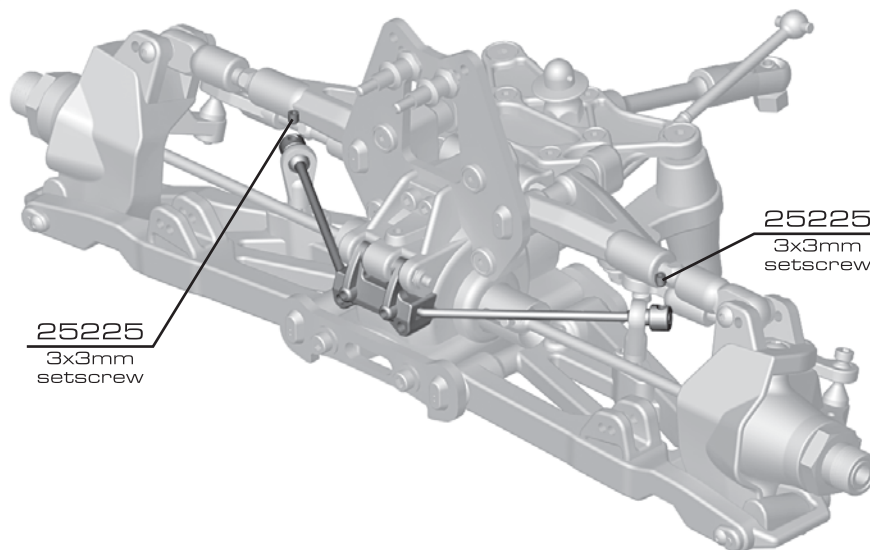

**:: Suspension (cont.)**

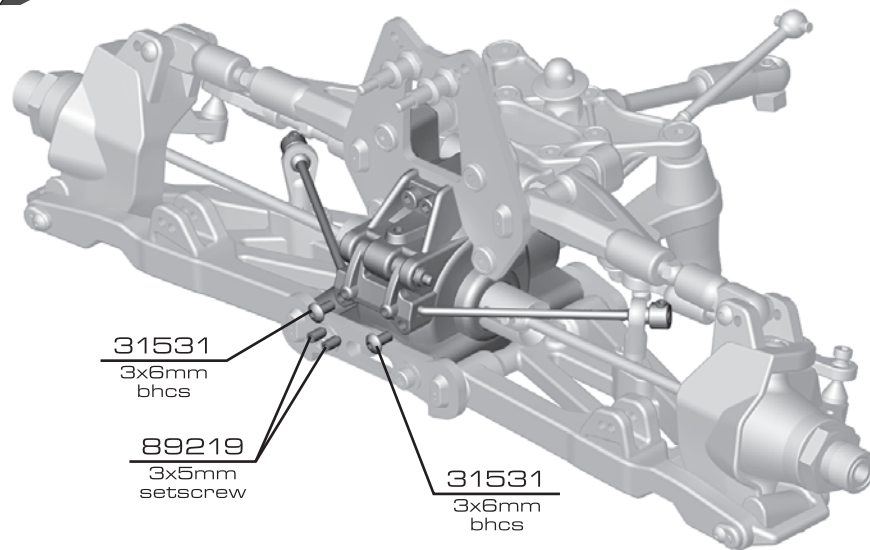

**:: Suspension (cont.)**

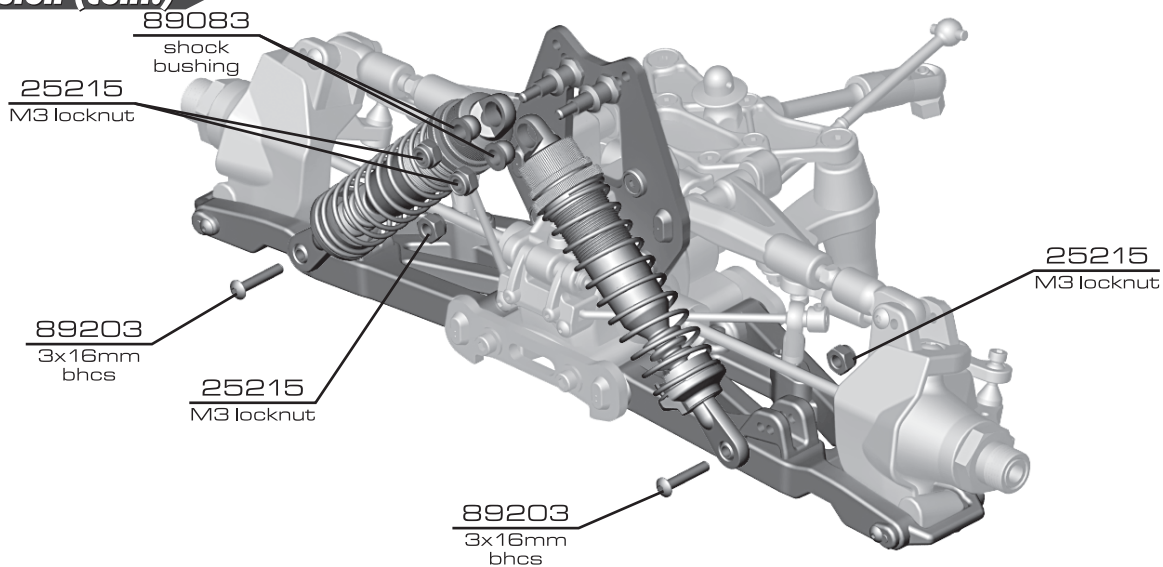

## :: Center Diff

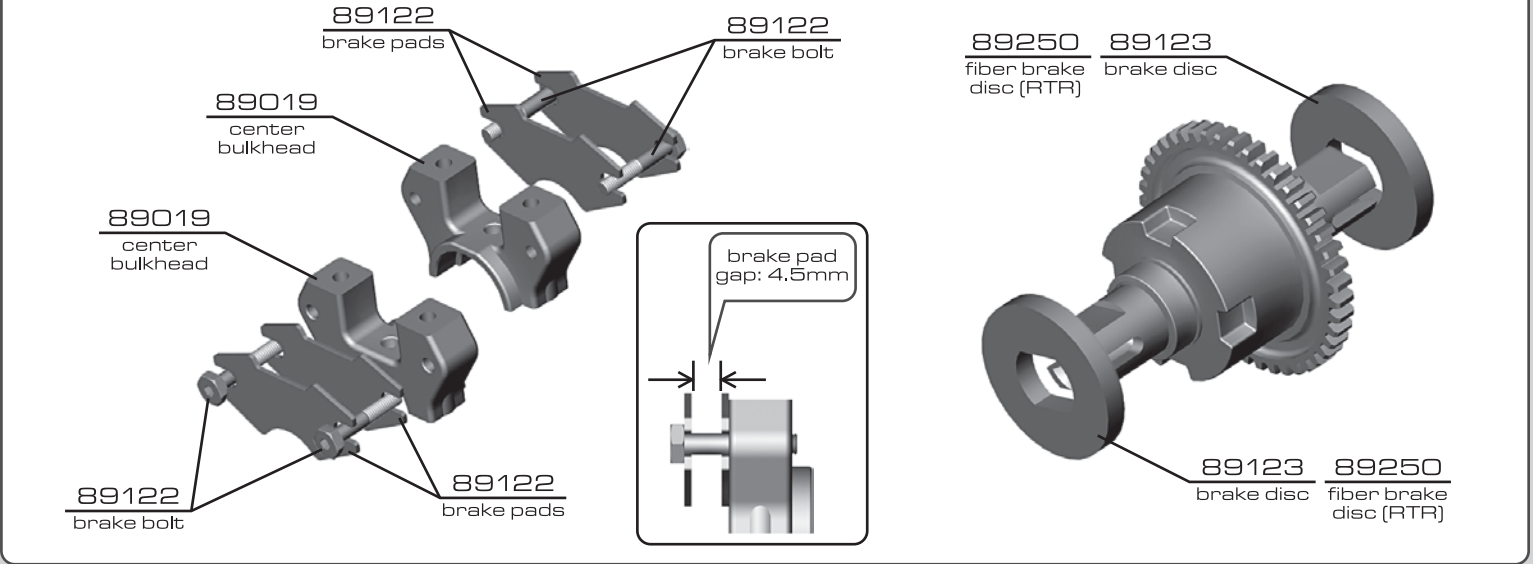

## :: Center Diff (cont.)

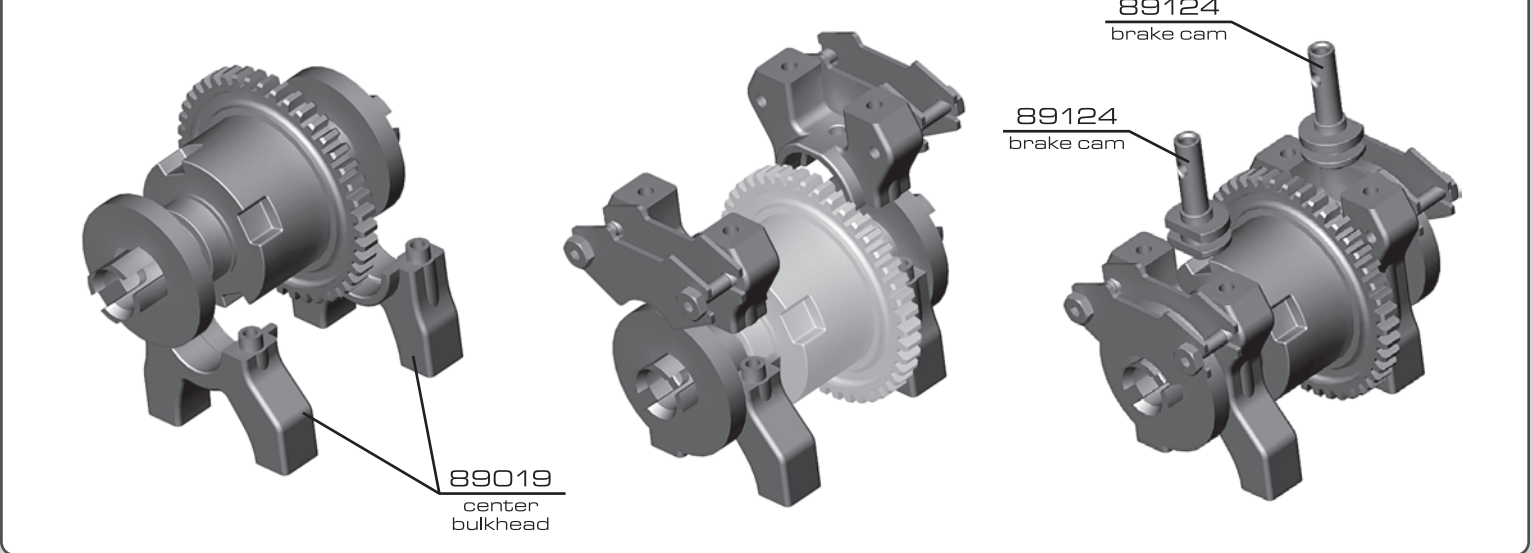

## :: Center Diff (cont.)

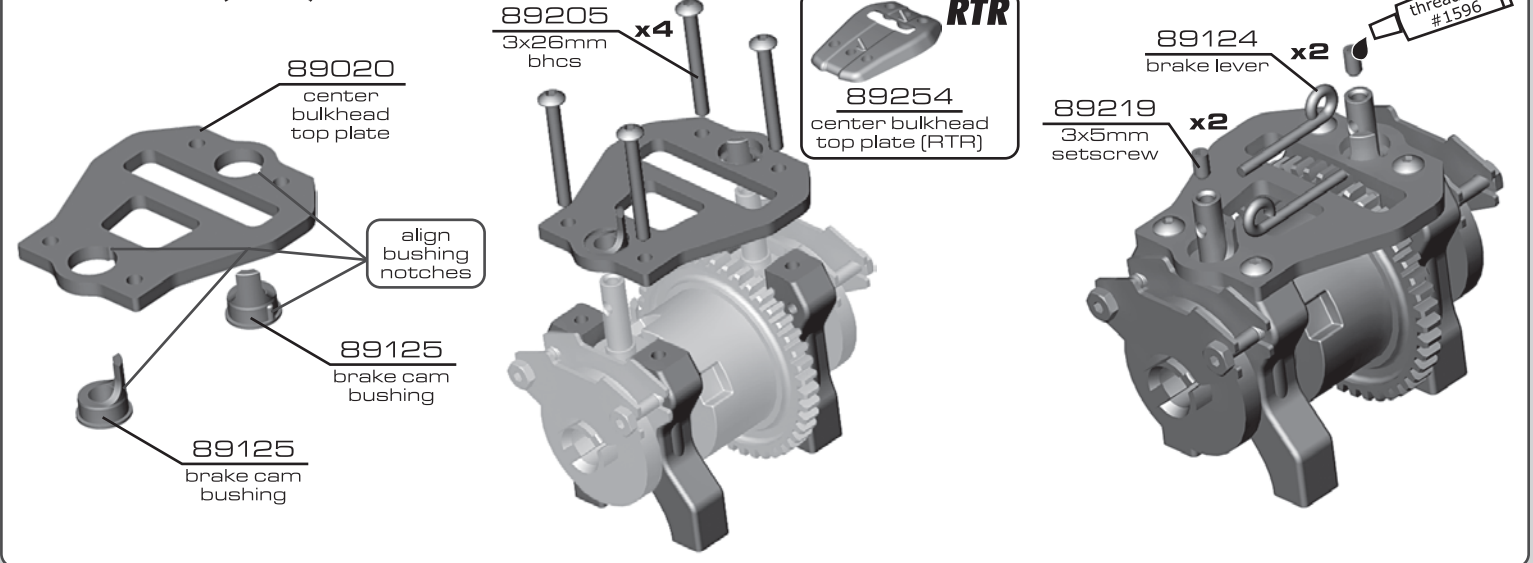

:: Rear Gearbox

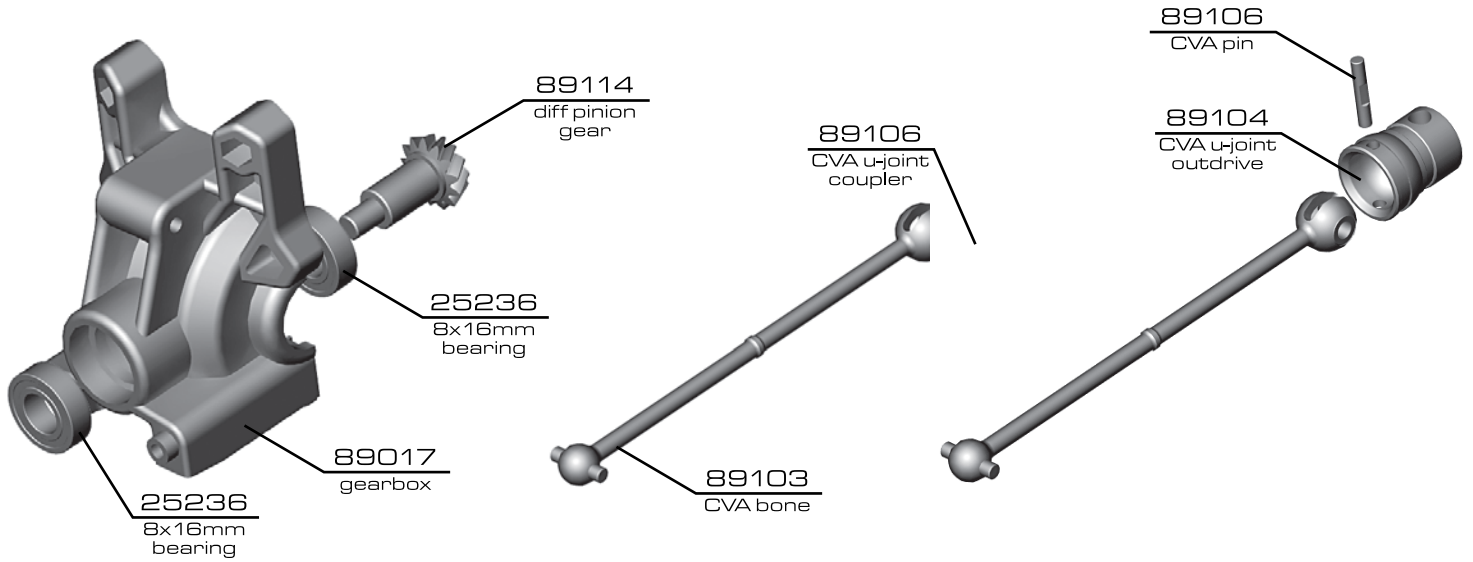

:: Rear Gearbox (cont.)

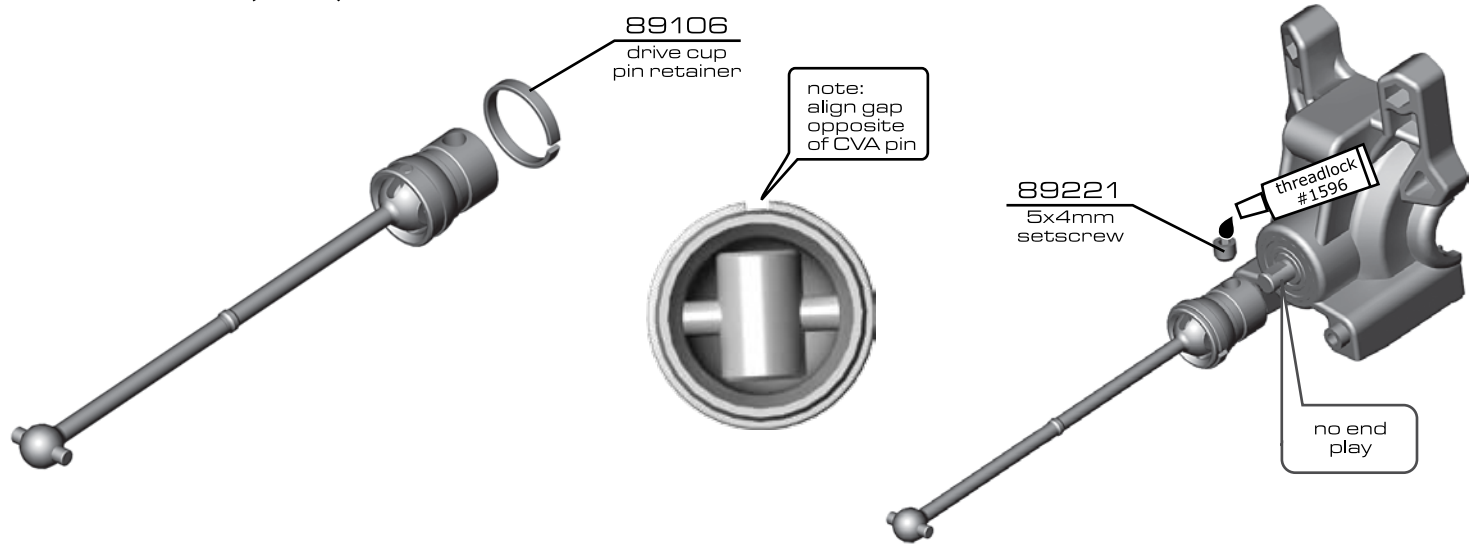

:: Rear Gearbox (cont.)

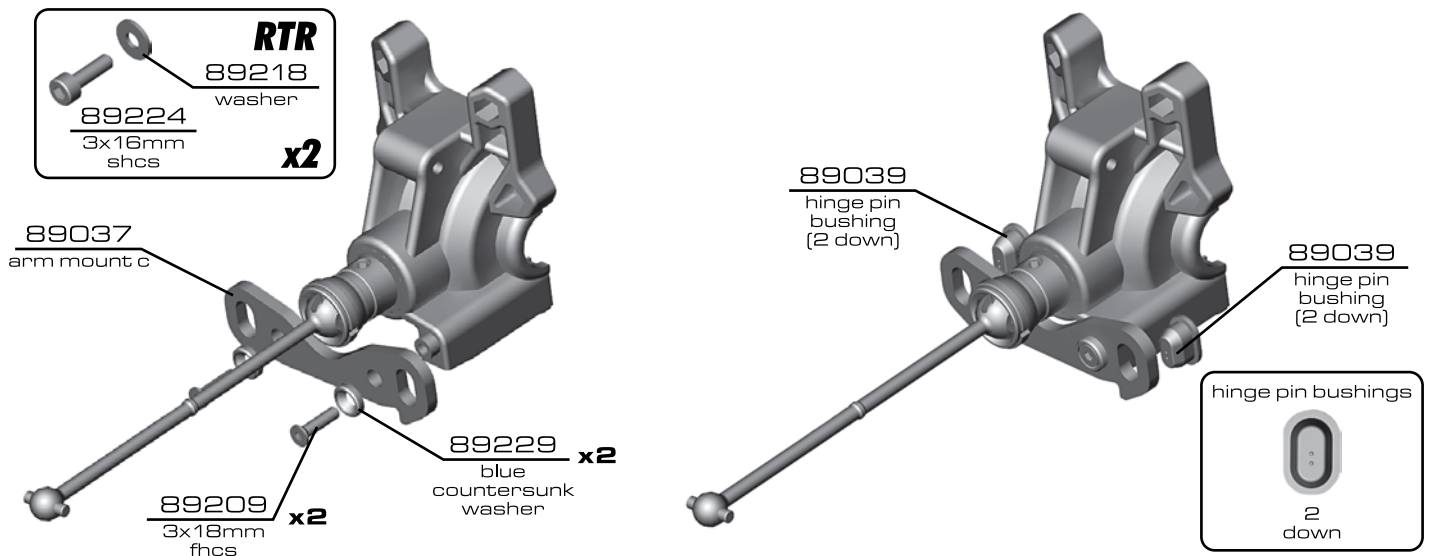



## :: Rear Gearbox (cont.)

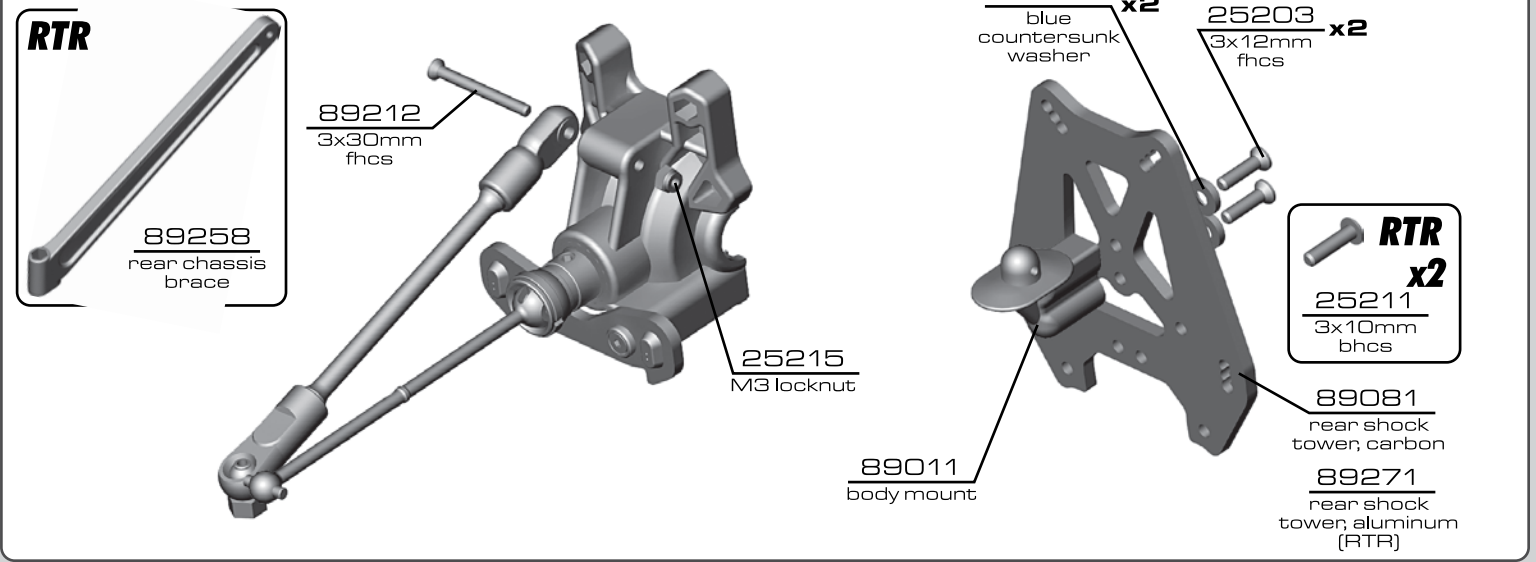

## :: Rear Gearbox (cont.)

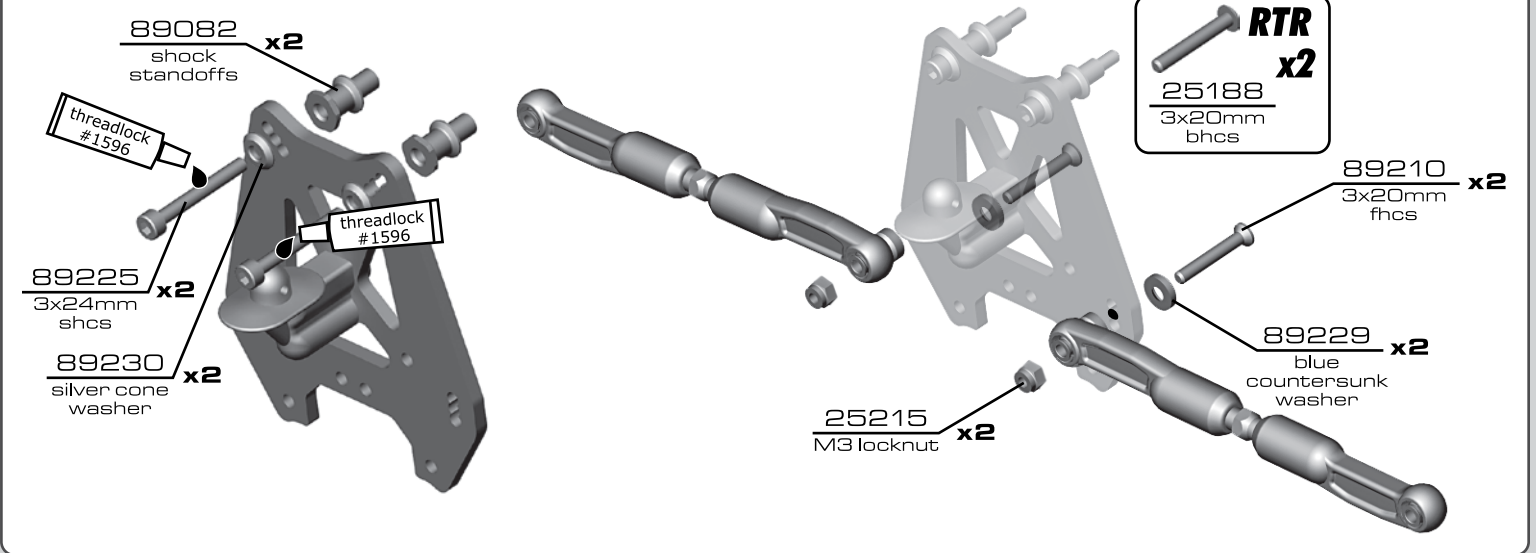

## :: Rear Gearbox (cont.)

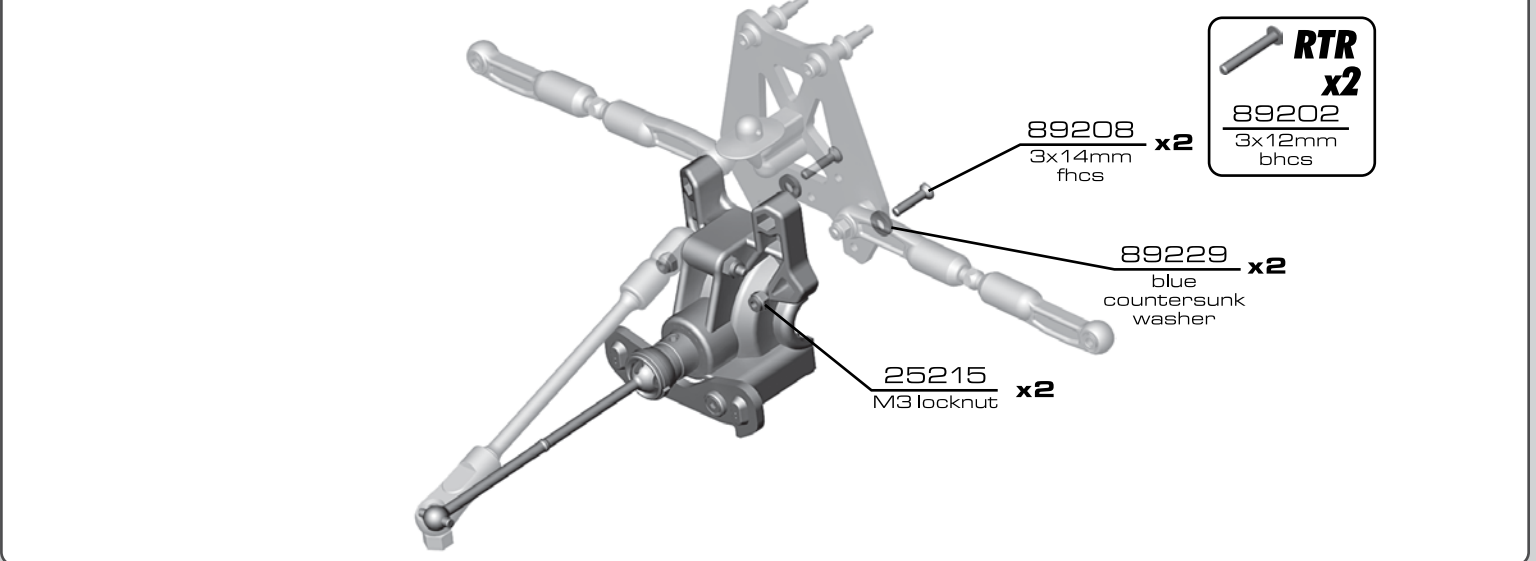

**:: Rear Gearbox (cont.)**

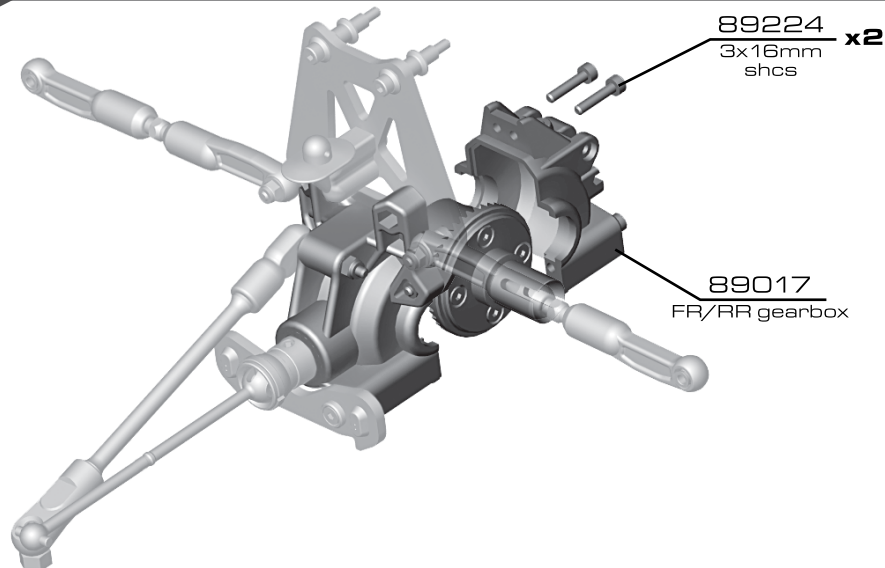

**:: Suspension**

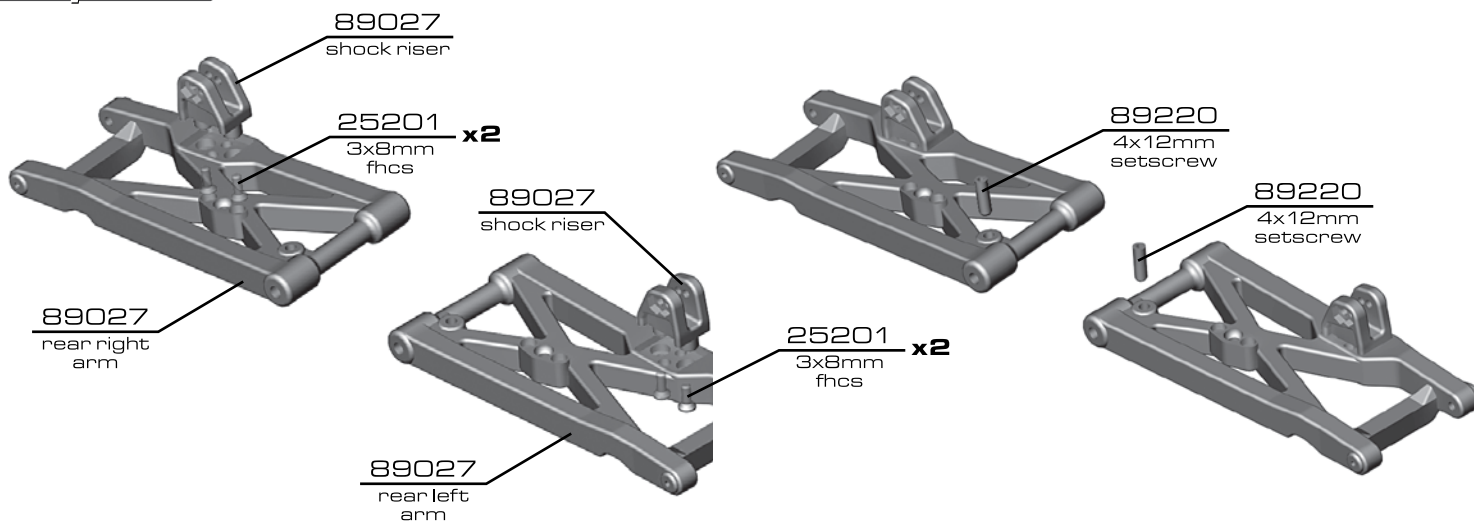

**:: Suspension (cont.)**

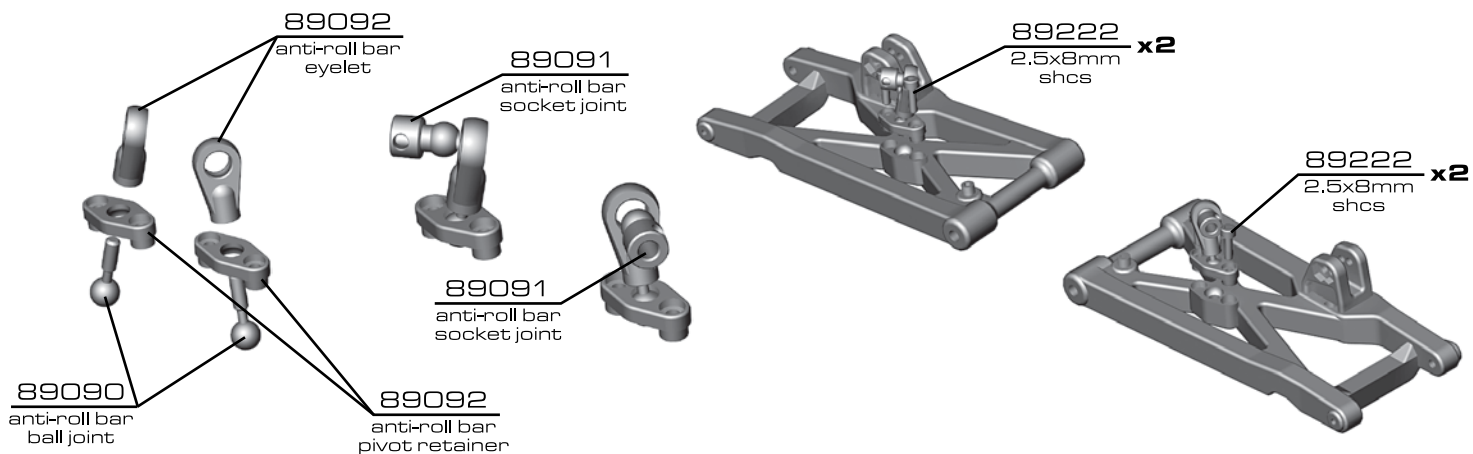

## :: Suspension (cont.)

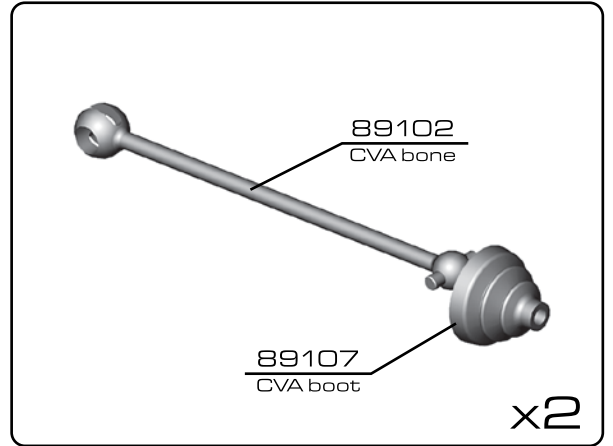
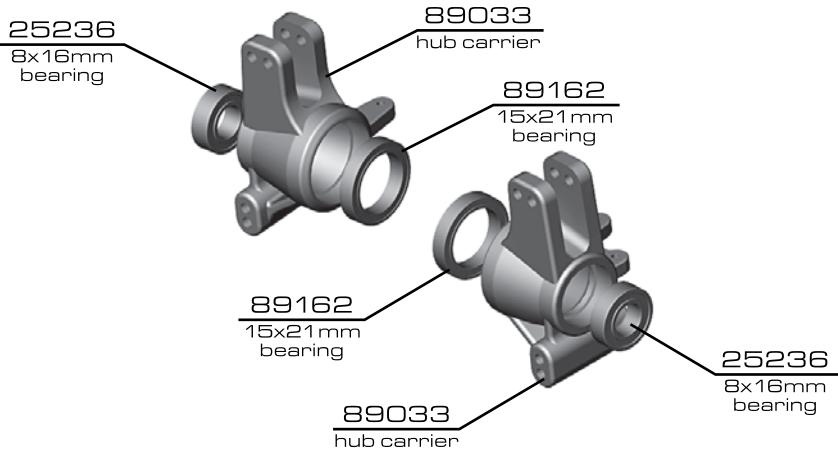

## :: Suspension (cont.)

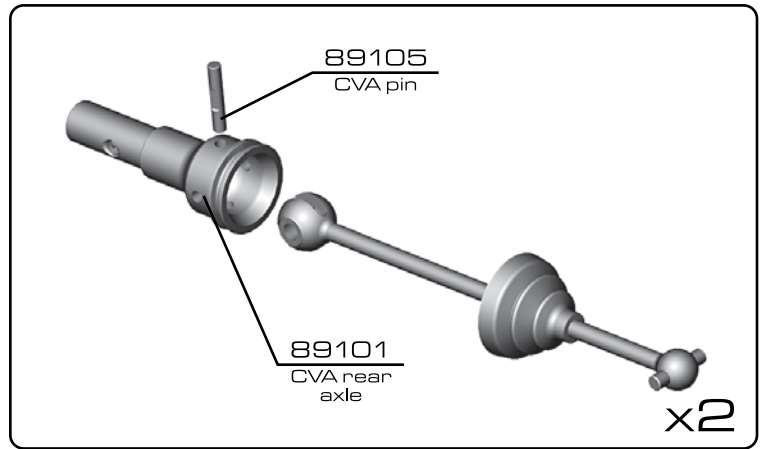
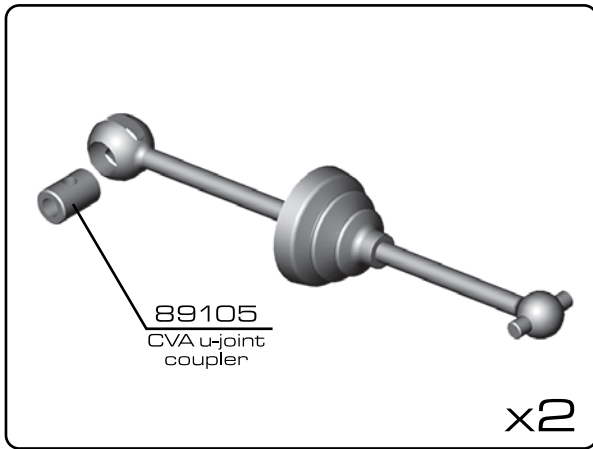

## :: Suspension (cont.)

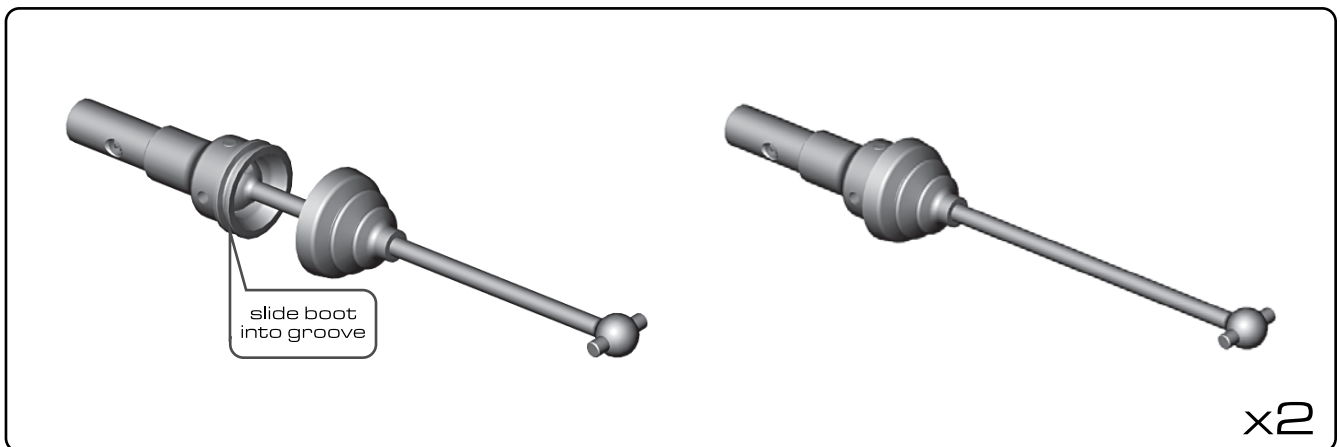

**:: Suspension (cont.)**

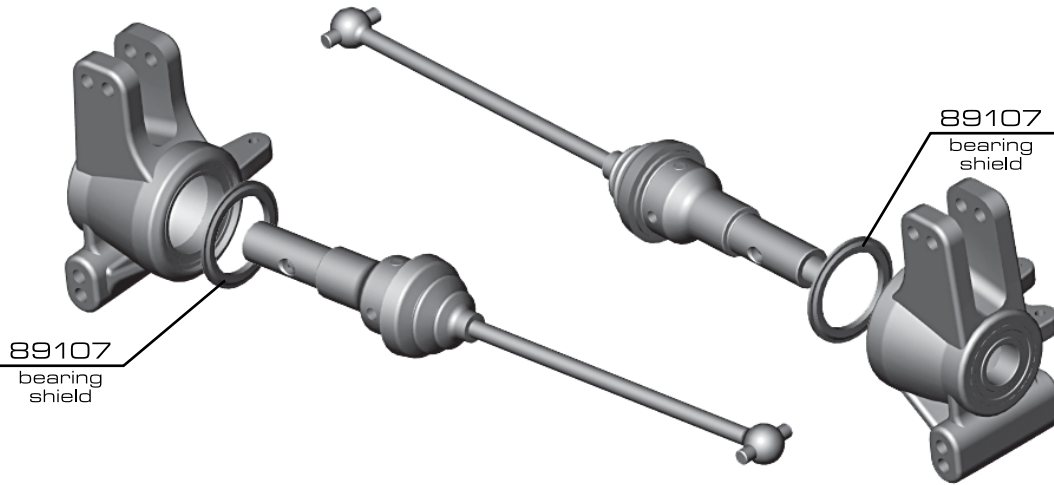

**:: Suspension (cont.)**

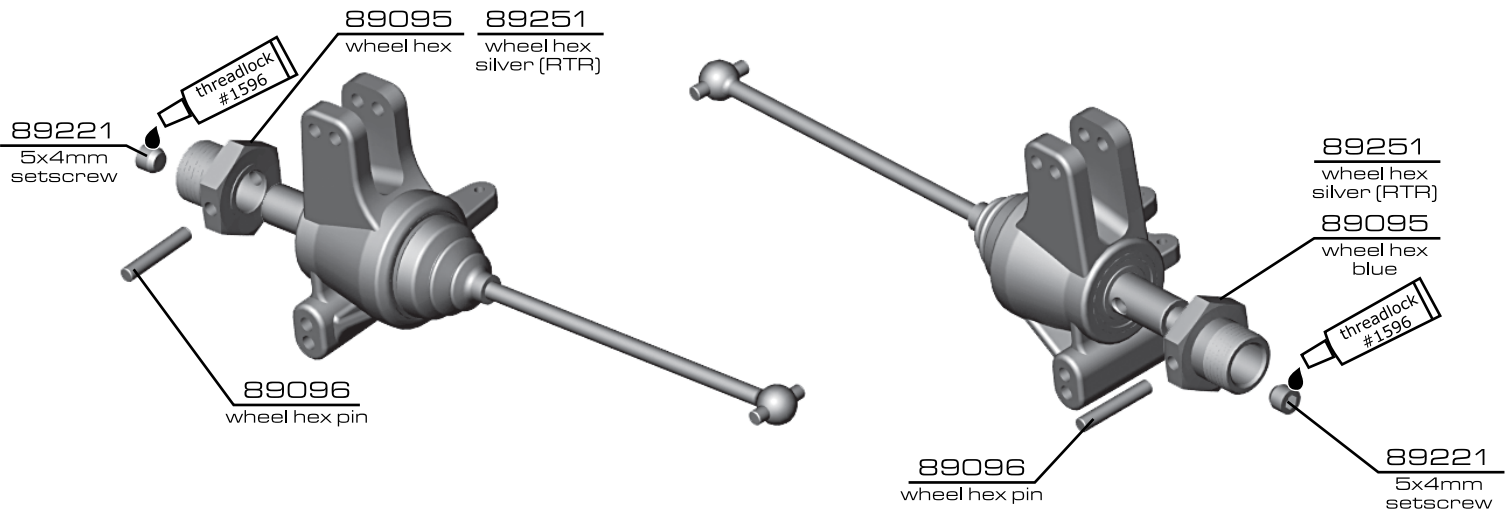

**:: Suspension (cont.)**

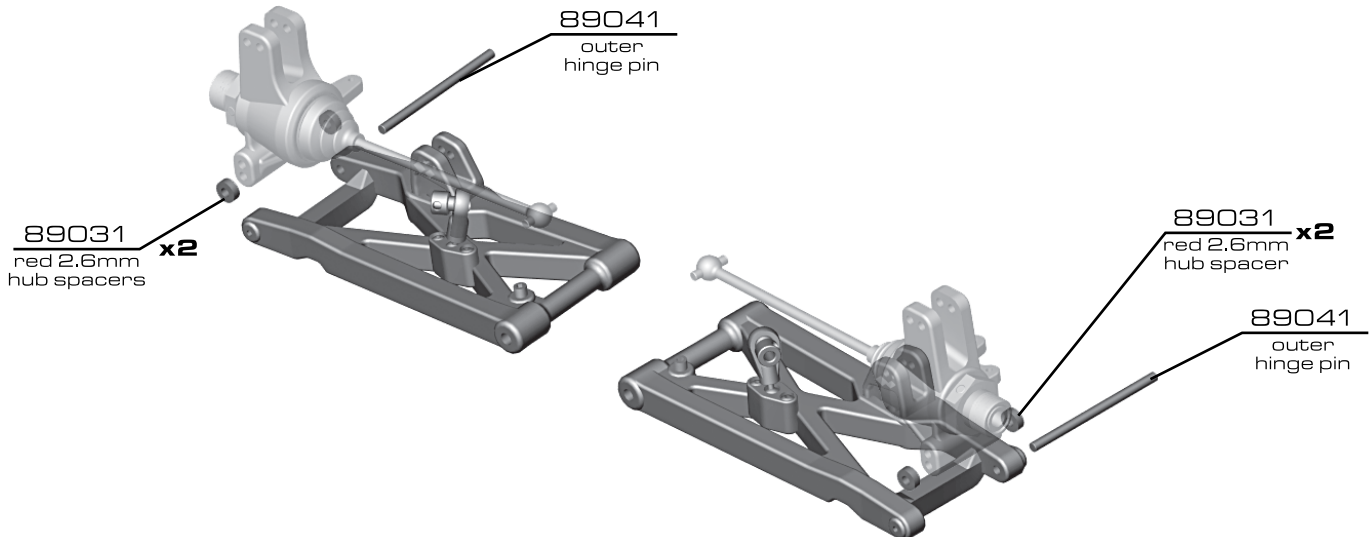



## :: Suspension (cont.)

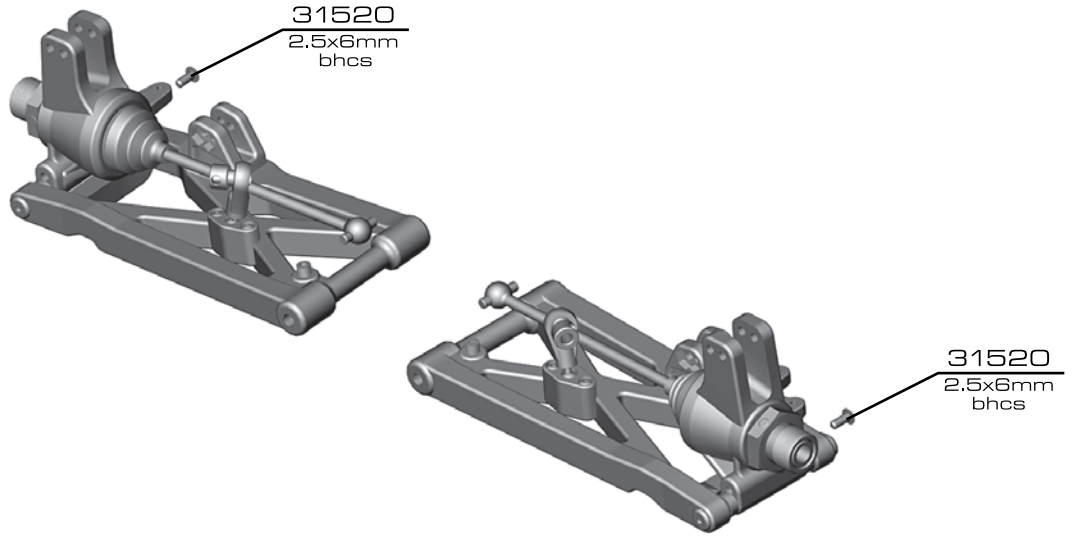

## :: Suspension (cont.)

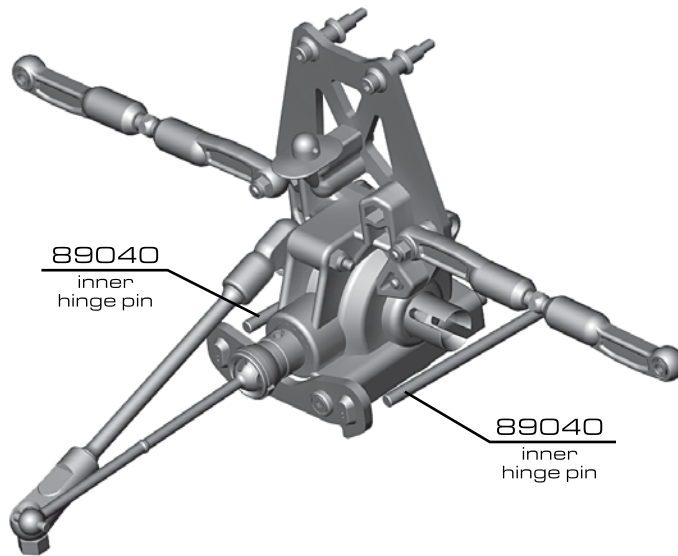

## :: Suspension (cont.)

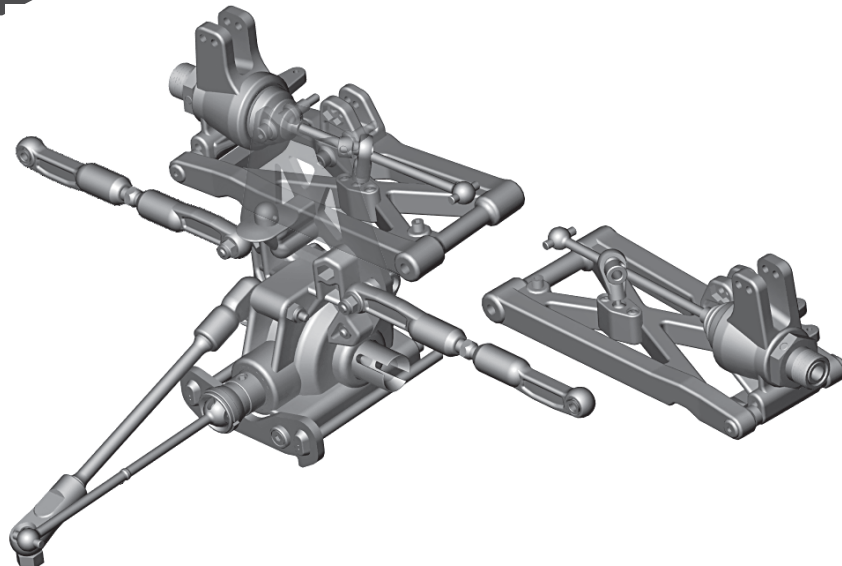

:: Suspension (cont.)

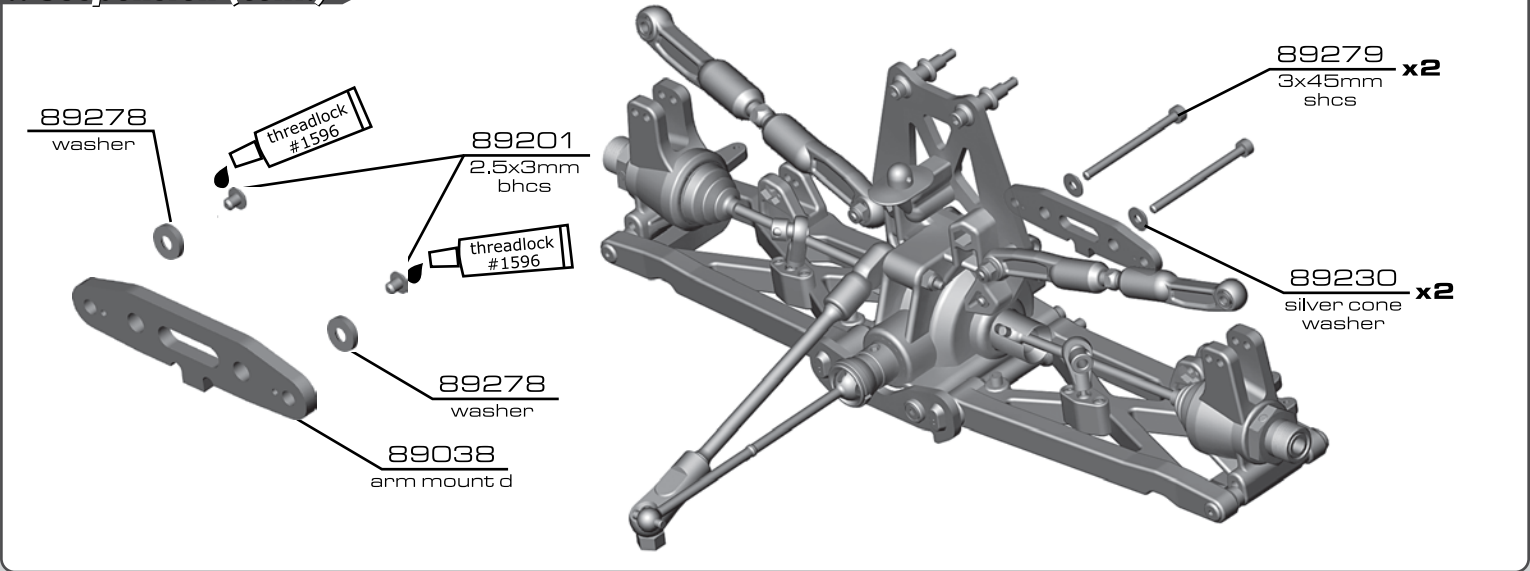

:: Suspension (cont.)

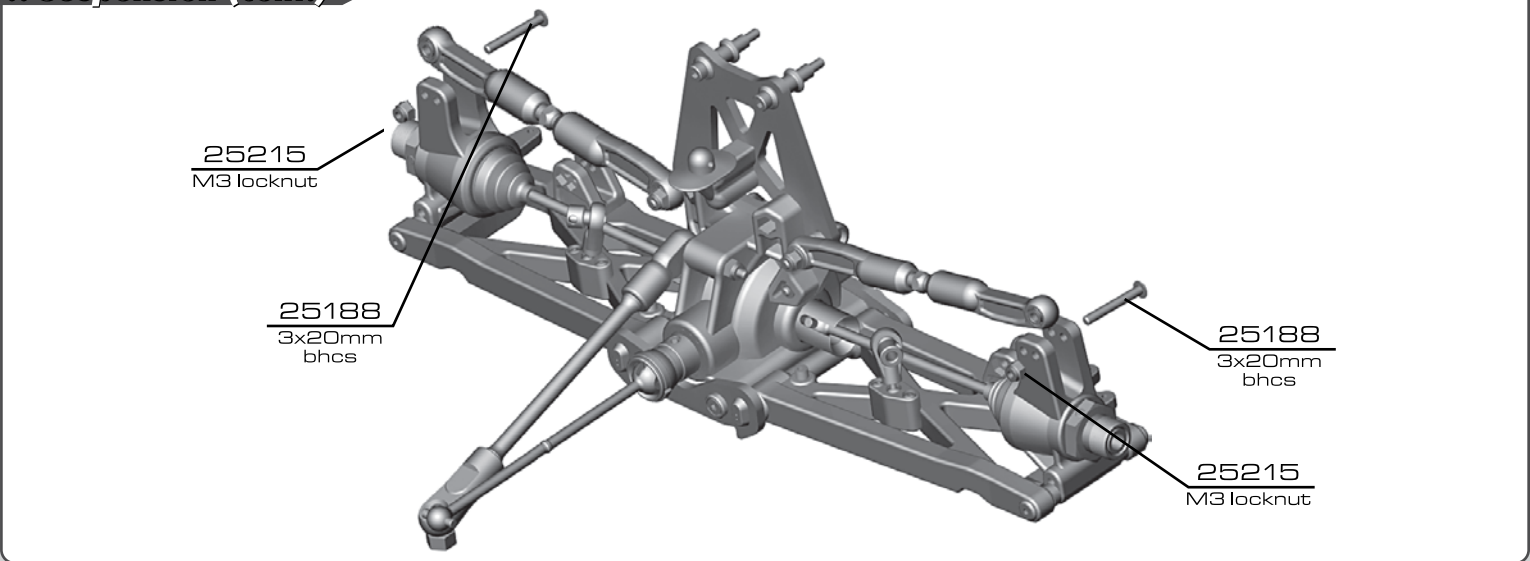

:: Suspension (cont.)

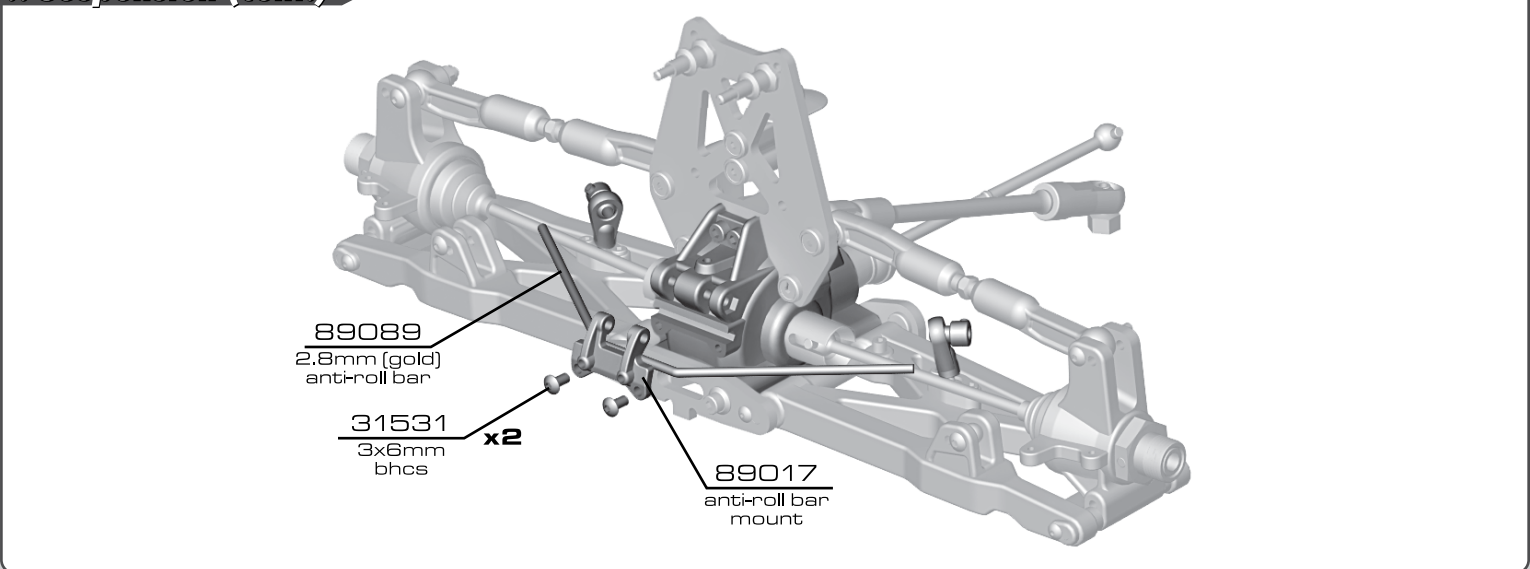

## :: Suspension (cont.)

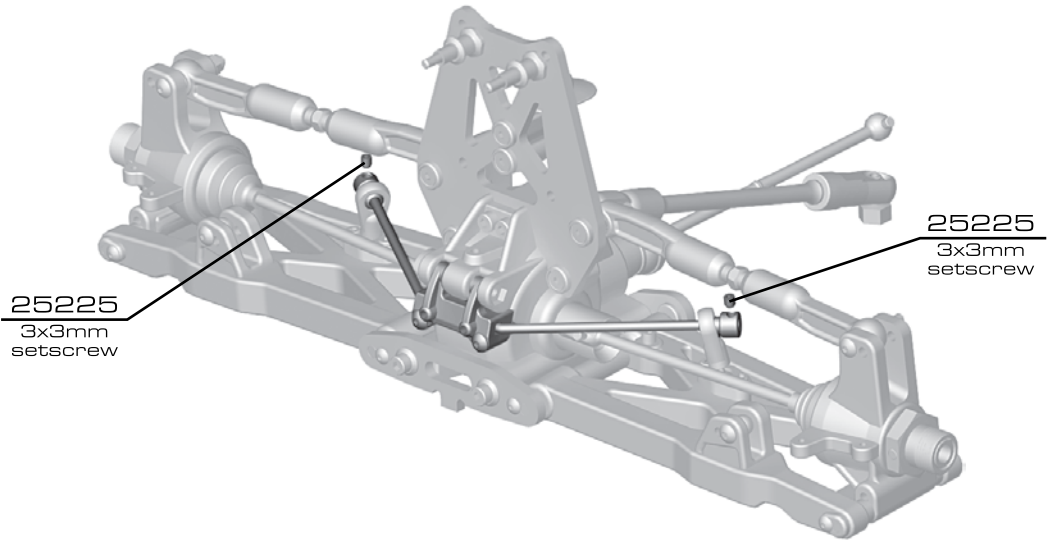

## :: Suspension (cont.)

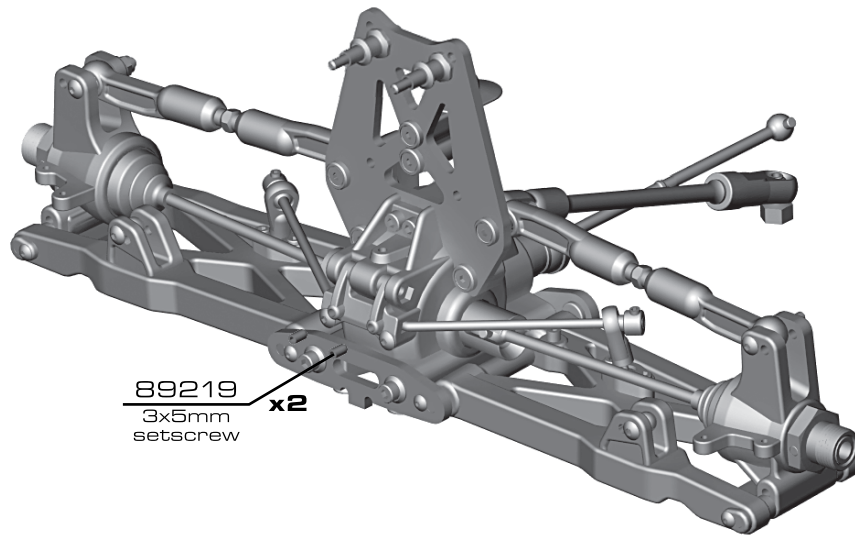

## :: Suspension (cont.)

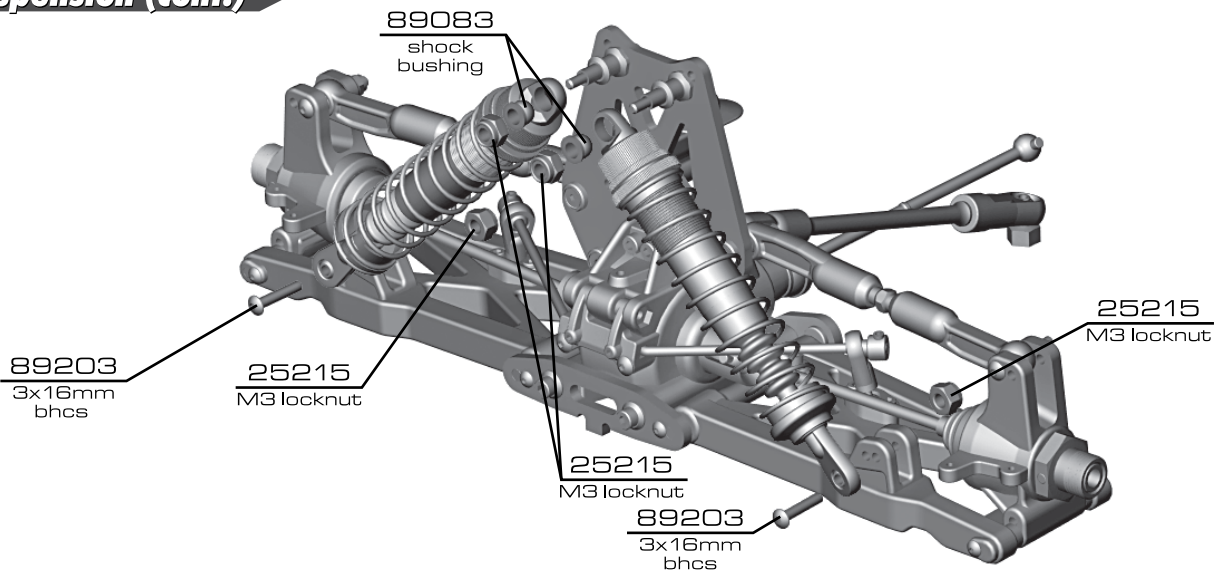

:: Wing

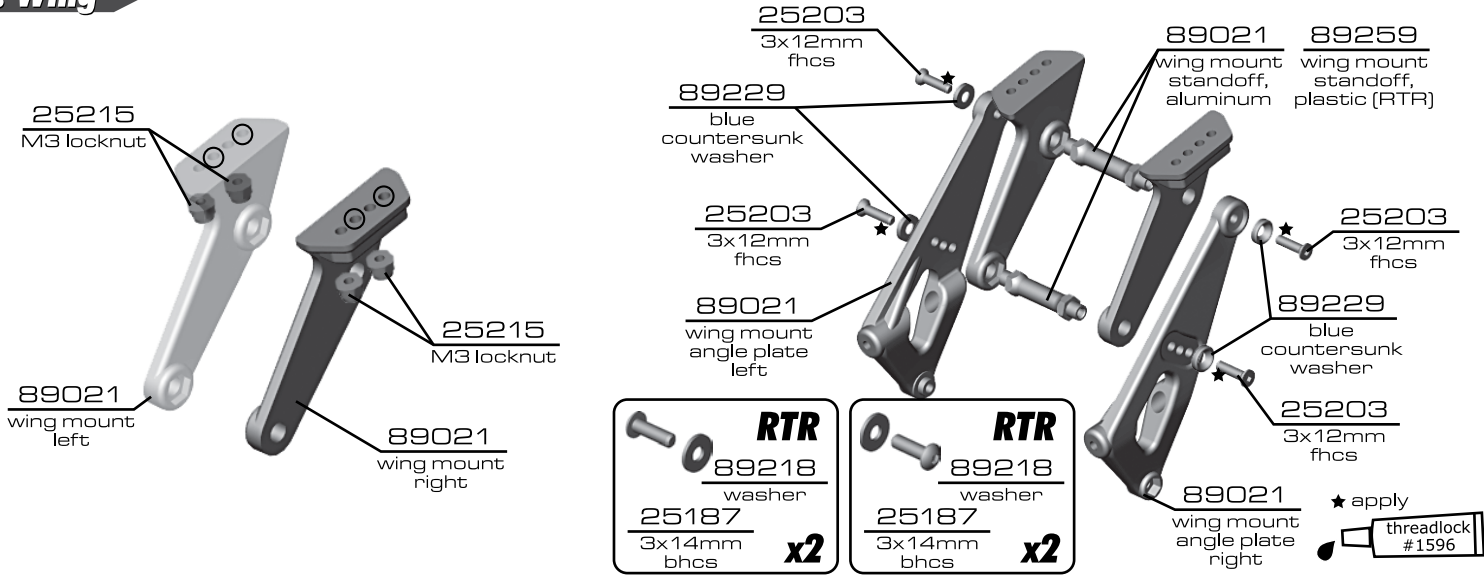

:: Wing (cont.)

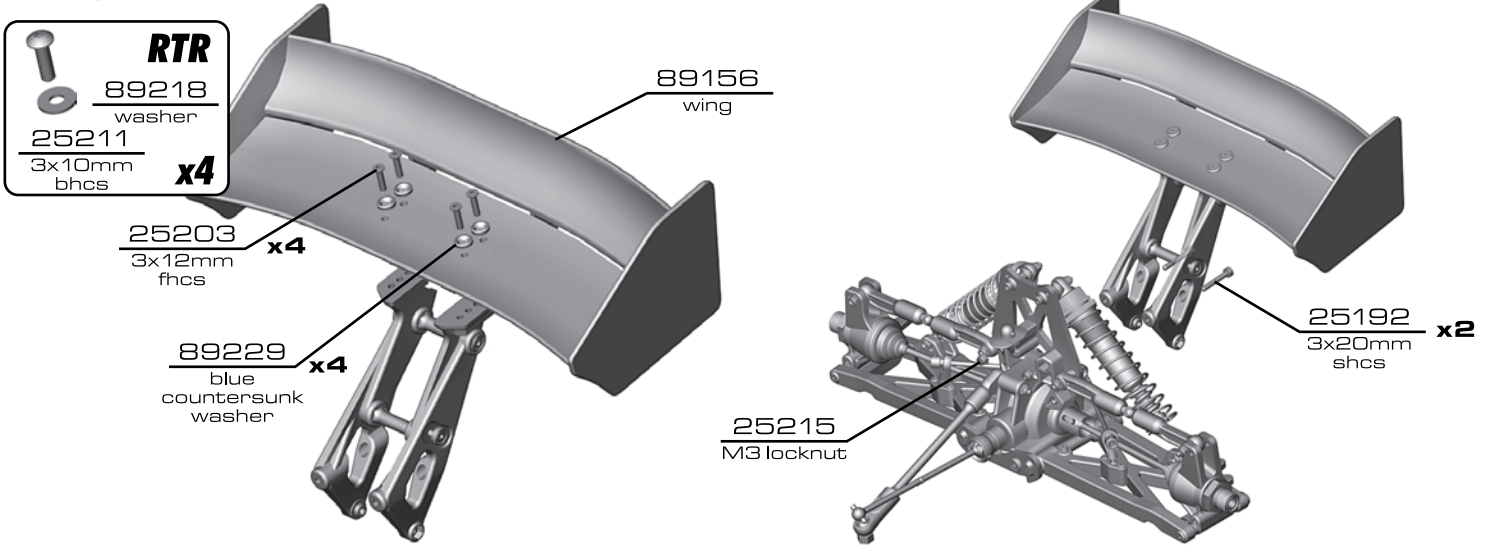

:: Wing (cont.)

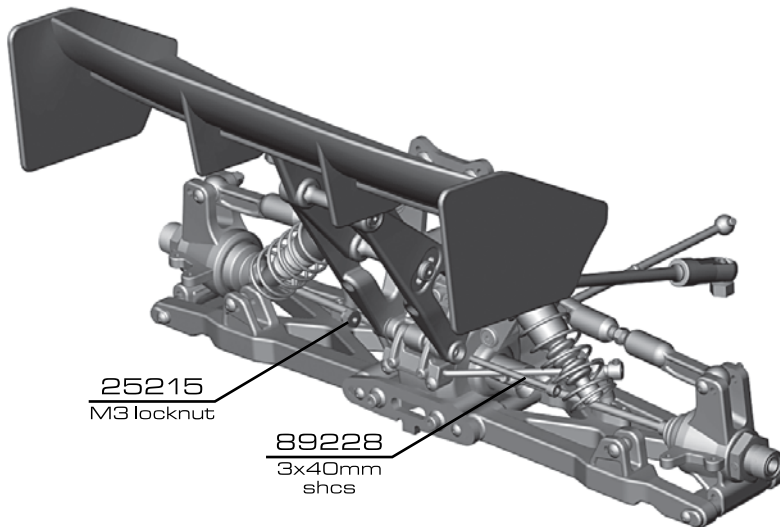



## :: Chassis Assembly

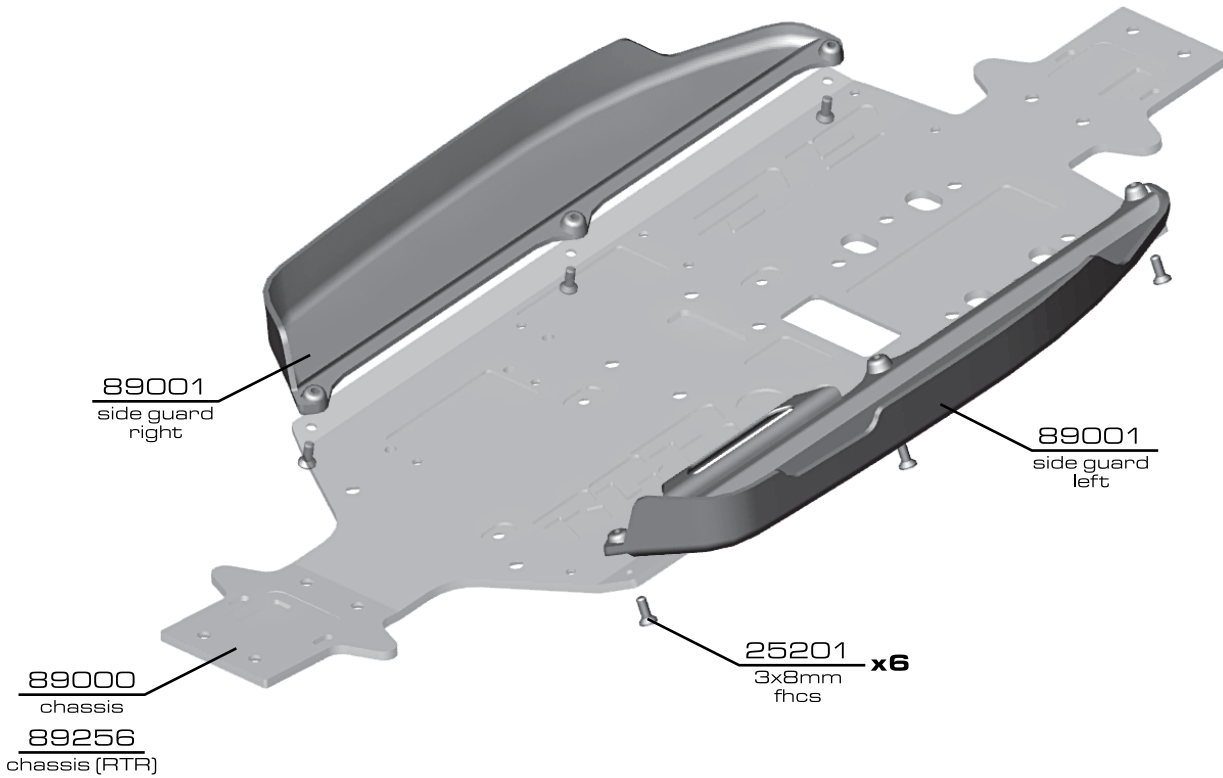

## :: Chassis Assembly (cont.)

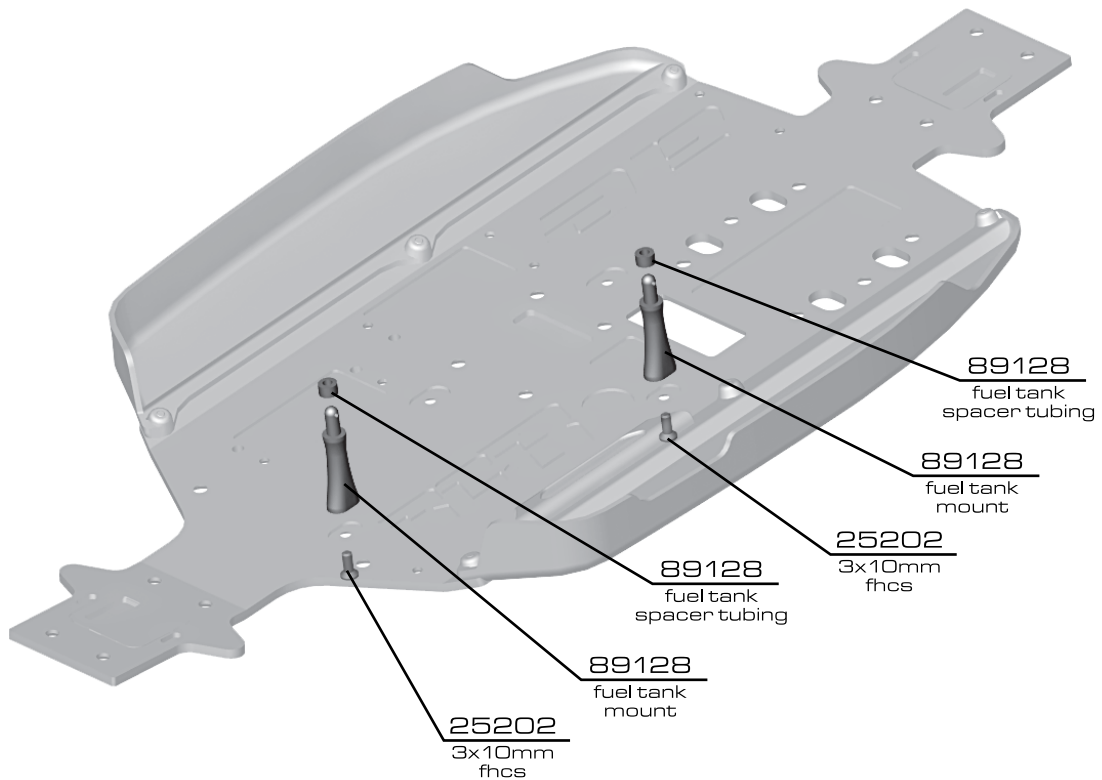

:: Chassis Assembly (cont.)

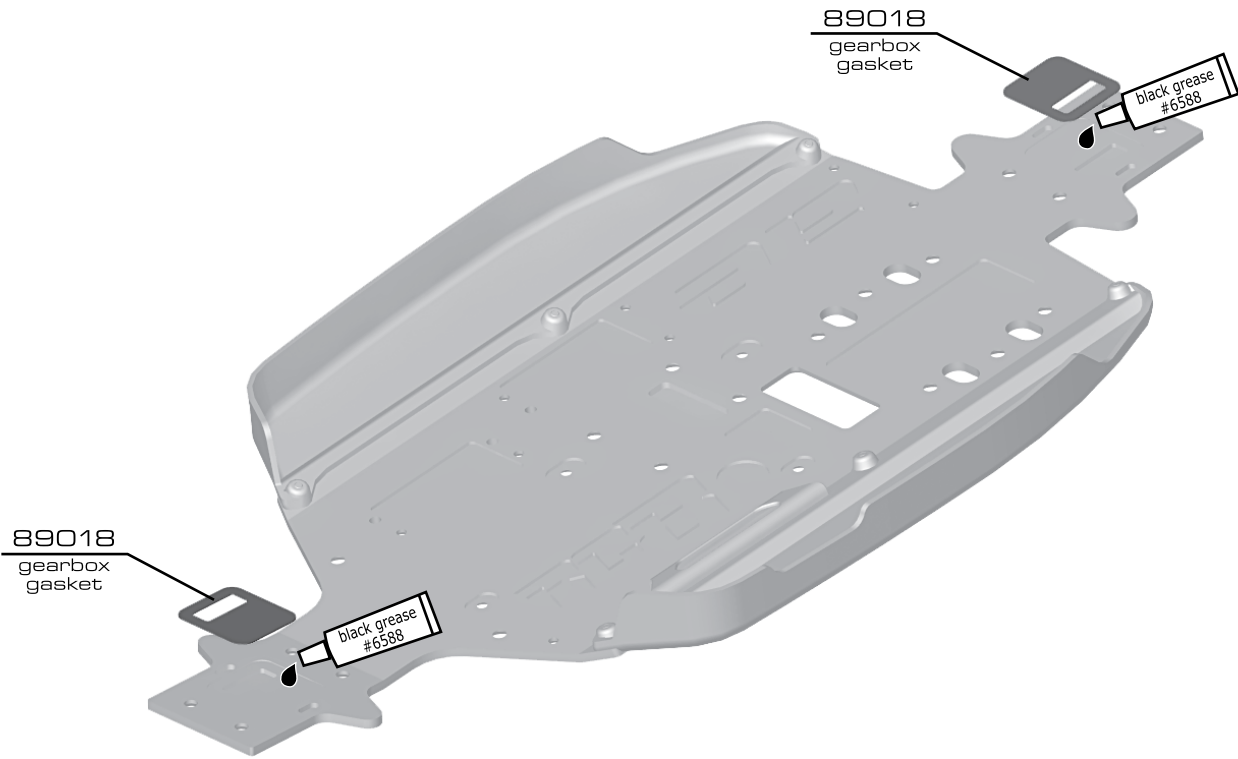

:: Front End Assembly

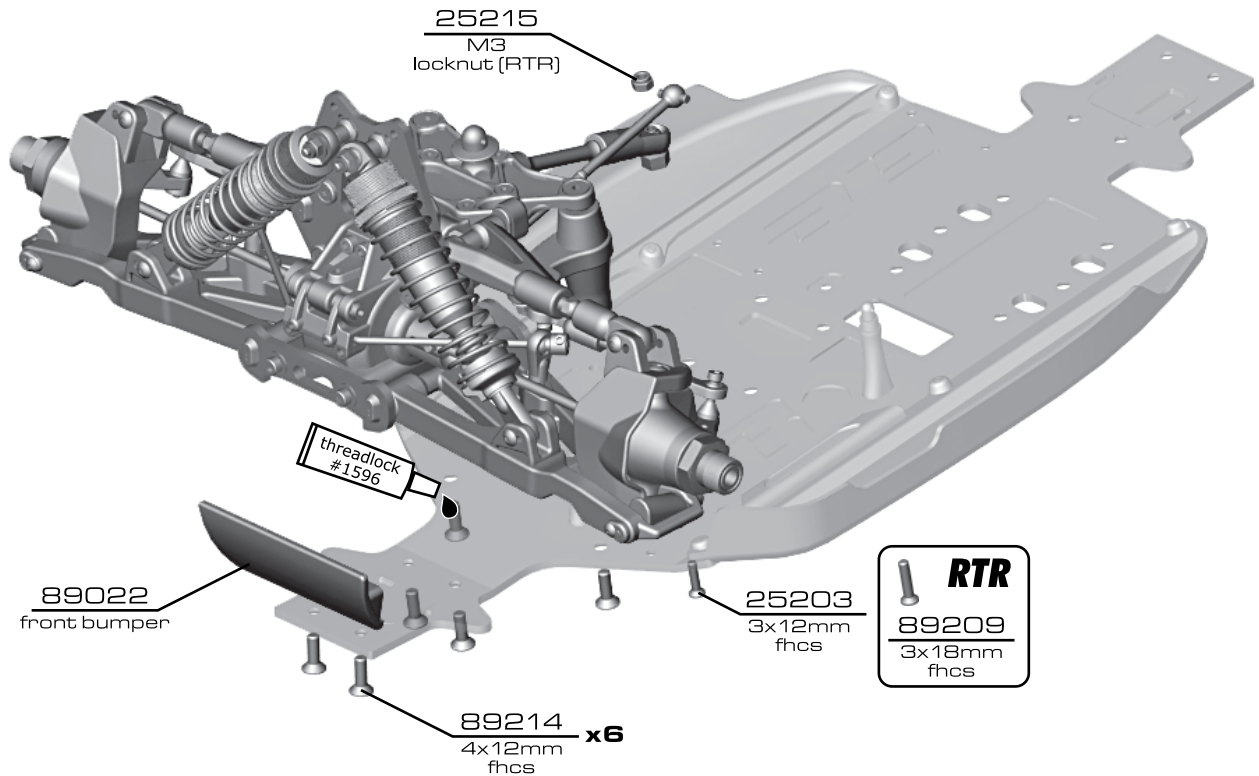

## :: Center Diff Assembly

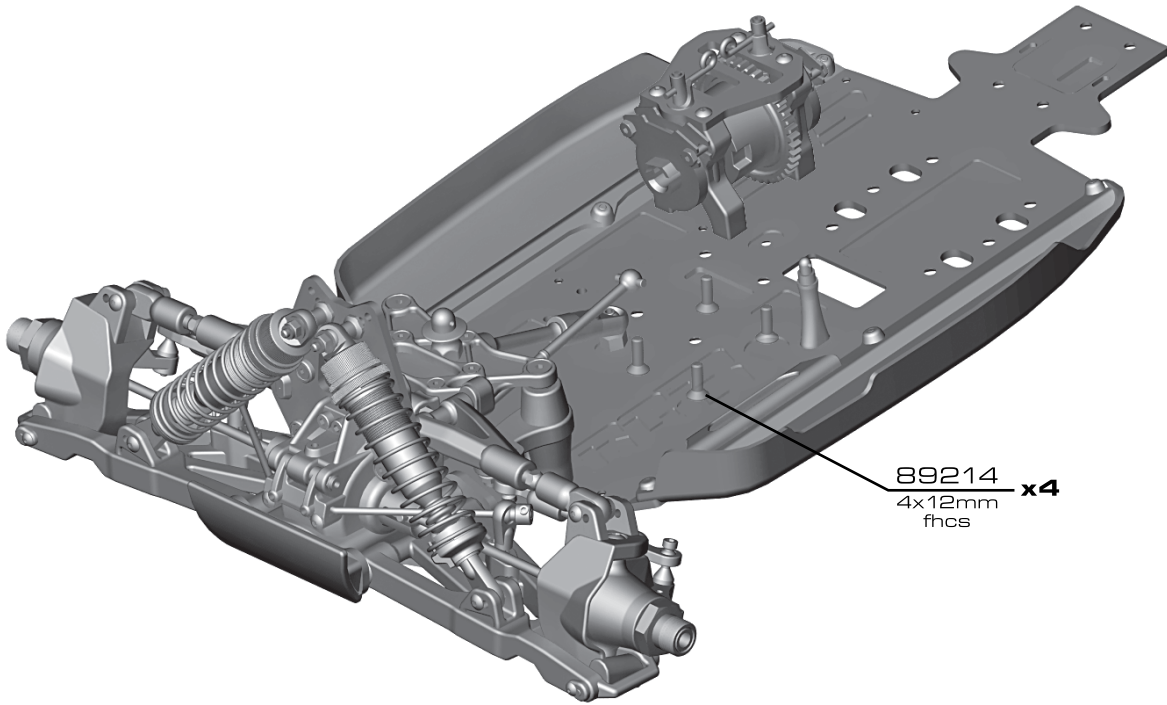

## :: Rear End Assembly

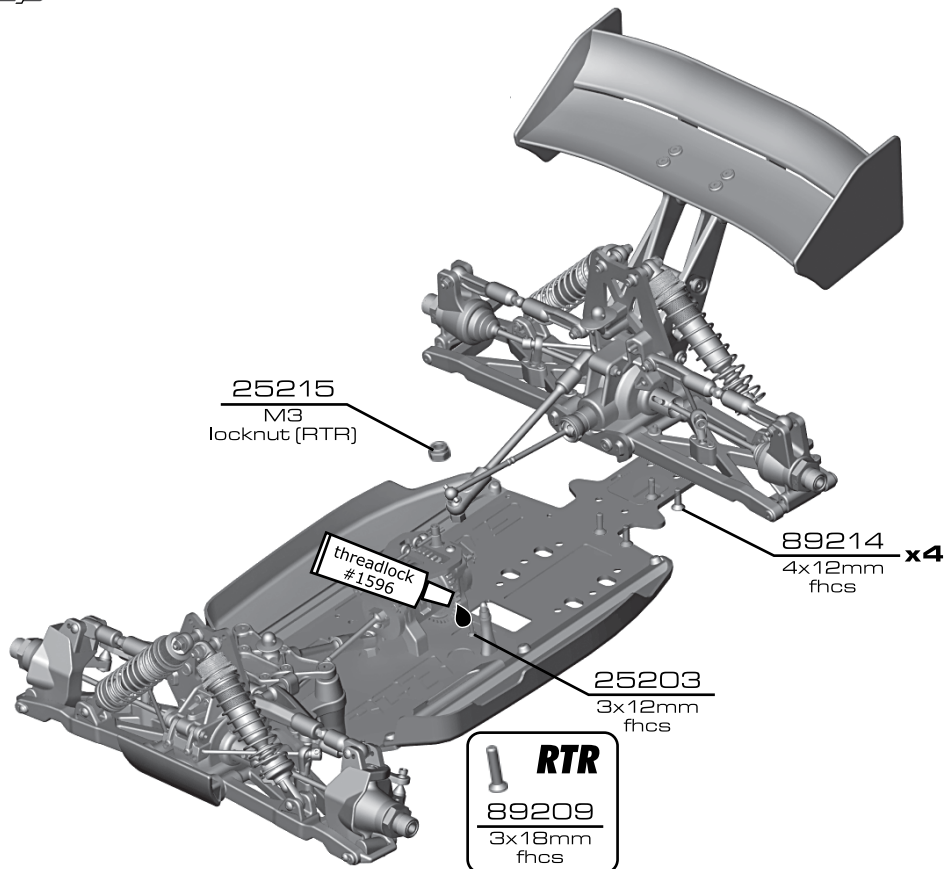

:: Fuel Tank Assembly

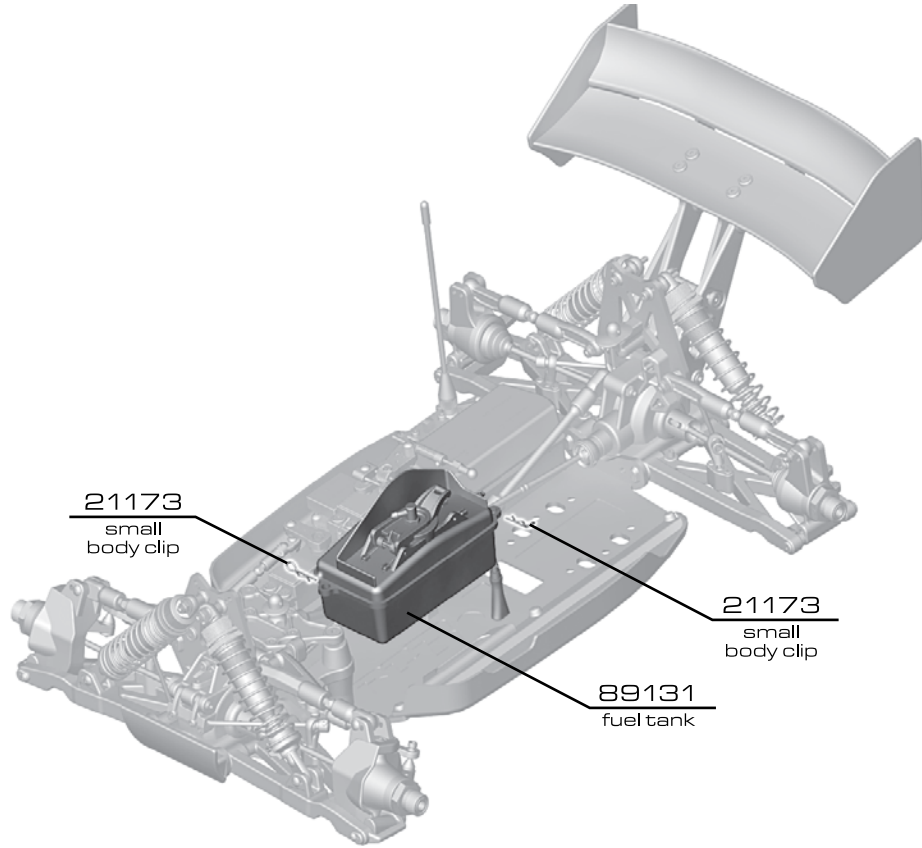

:: Exhaust Pipe Hanger

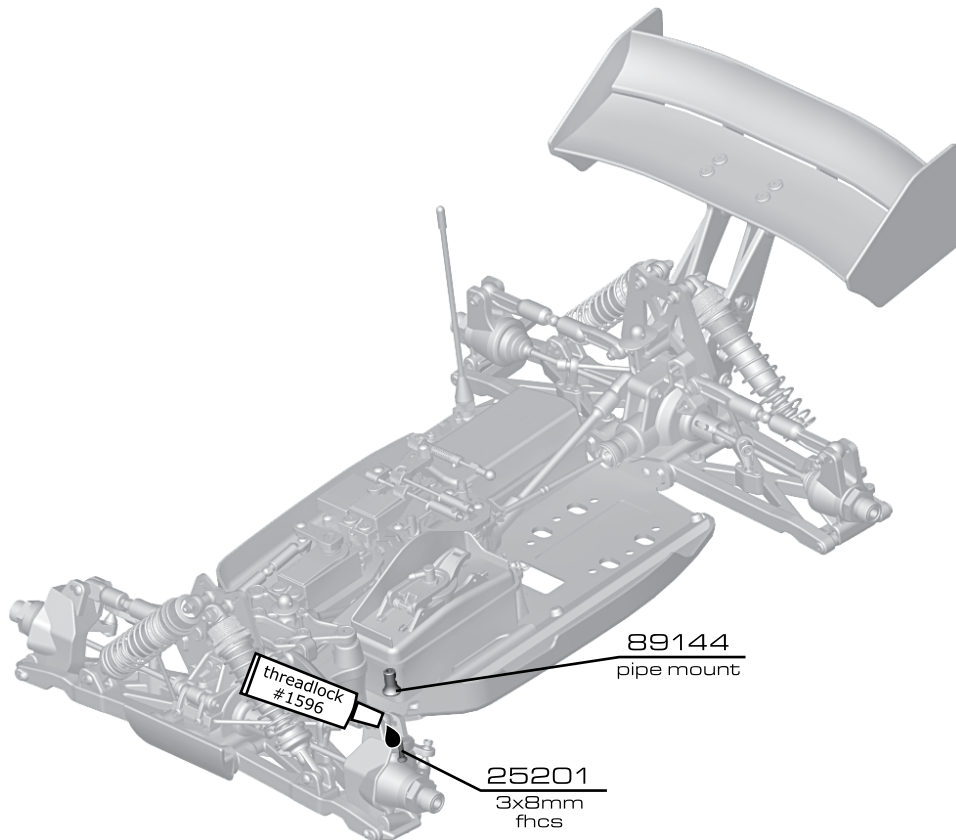



## :: Exhaust Pipe Hanger (cont.)

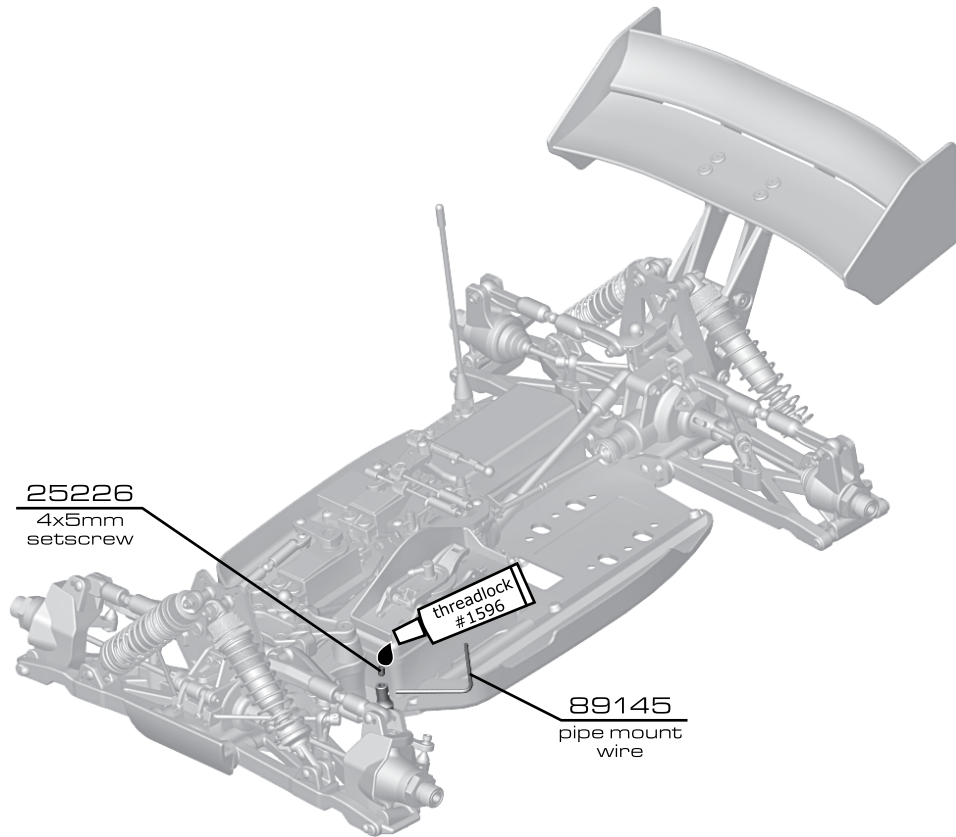

## :: Engine Assembly

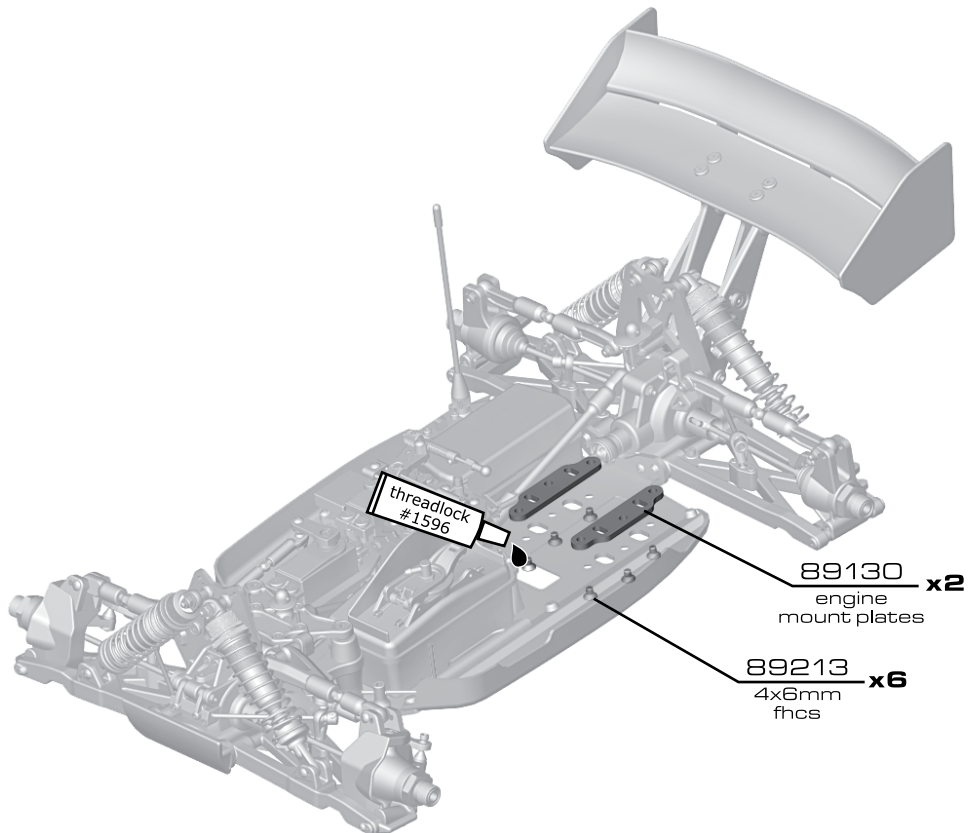

**:: Radio Tray**

**Bag 34-1**

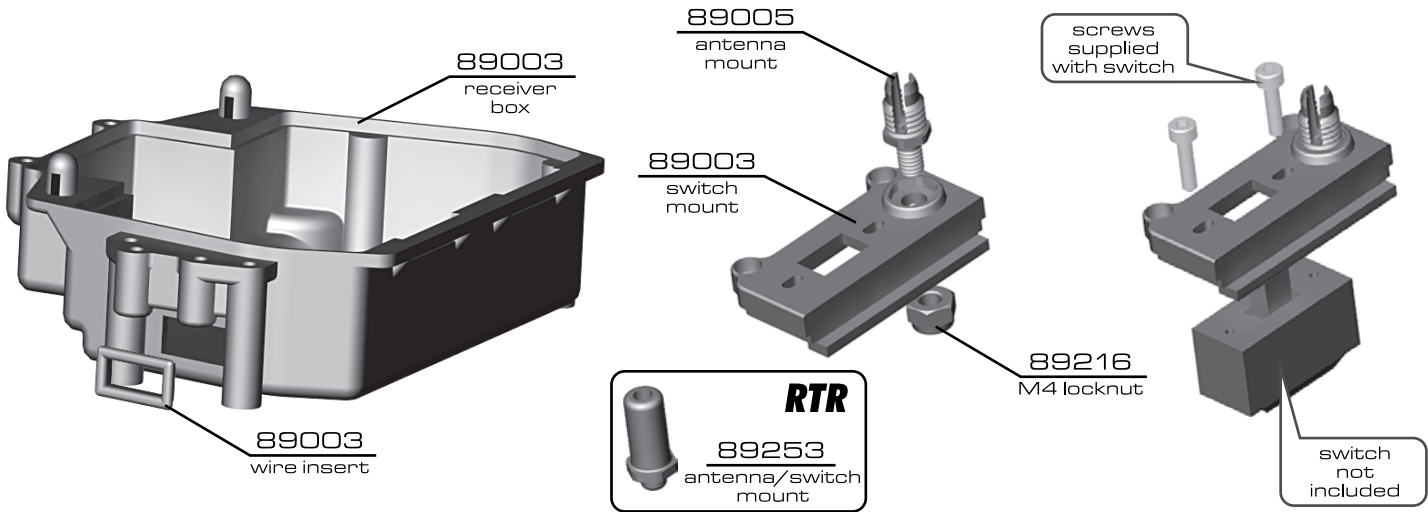

**:: Radio Tray (cont.)**

**Bag 34-2**

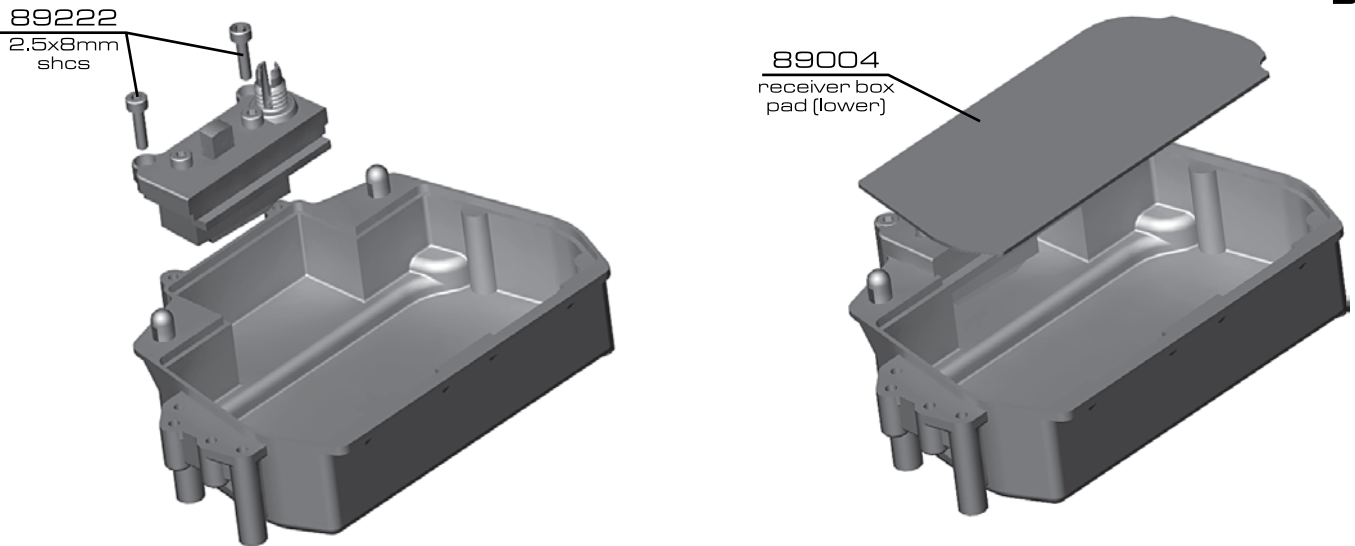

**:: Radio Tray (cont.)**

**Bag 34-3**

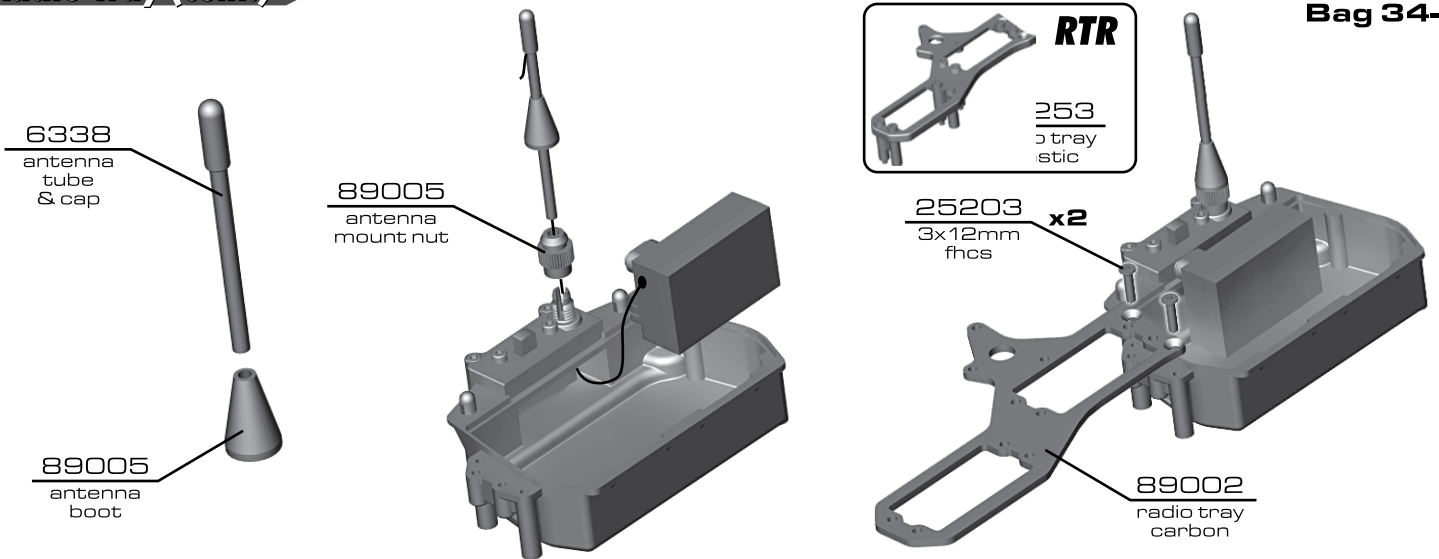

## :: Radio Tray (cont.)

**Bag 35-1**

**25187 RTR**  
3x14mm bhcs

**89218**  
washer **x8**

- 89209** 3x18mm fhcs **x4**
- 89229** blue countersunk washers **x4**
- 89006** servo spacers (1 thin, 1 thick)
- 89006** servo mount **x2**
- 89229** blue countersunk washers
- 89209** 3x18mm fhcs
- 89006** servo spacers (1 thin, 1 thick)
- 89006** servo mount

## :: Radio Tray (cont.)

**Bag 35-2**

**A - Airtronics**  
**F - Futaba**  
**H - Hitec**  
**J - JR**  
printed here

- 2308** 3x18mm bhcs
- 89007** steering servo horn
- 89007** servo horn ring
- 25215** M3 locknut
- 25201** 3x8mm fhcs
- 89007** servo cone washer

**▲ NOTE:** enlarge holes in servo horn.

## :: Radio Tray (cont.)

**Bag 35-3**

**A - Airtronics**  
**F - Futaba**  
**H - Hitec**  
**J - JR**  
printed here

**note:** when adjusting linkage it may be necessary to change hole location for correct alignment with carburetor

- 89203\*** 3x16mm bhcs
- 89202\*** 3x12mm bhcs
- 89126** throttle pivot
- 89126** bias brake block
- 89008** throttle servo horn
- 25215** M3 locknut
- 89008** servo horn ring
- 89126** M3 setscrew
- 89126** brake bias collar
- 89126** brake link

**▲ NOTE:** enlarge holes in servo horn.

**\* NOTE:** do not tighten completely - must pivot freely.

:: Radio Tray (cont.)

Bag 36-1

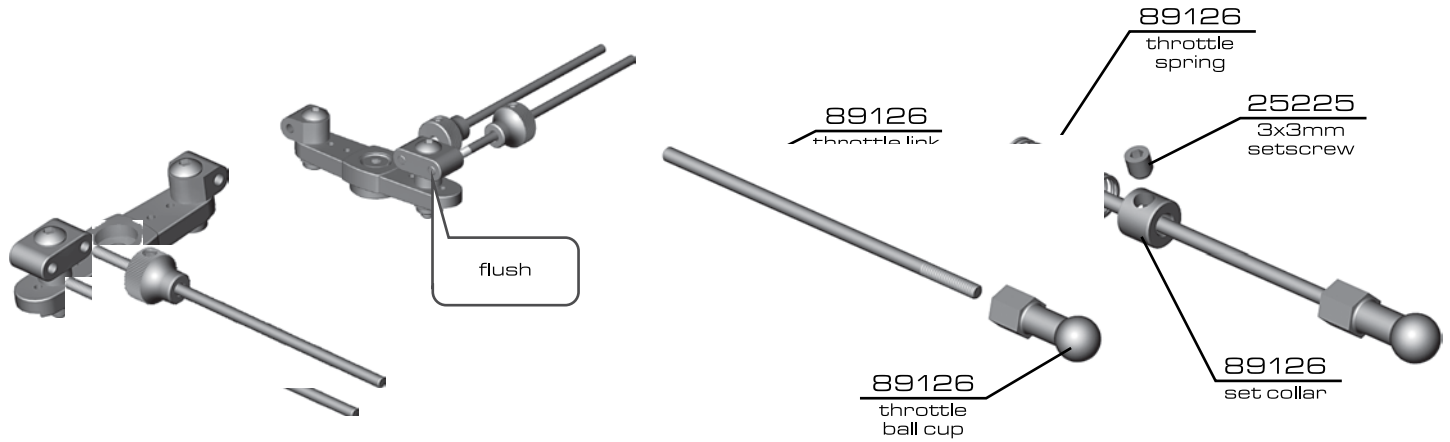

:: Radio Tray (cont.)

Bag 36-2

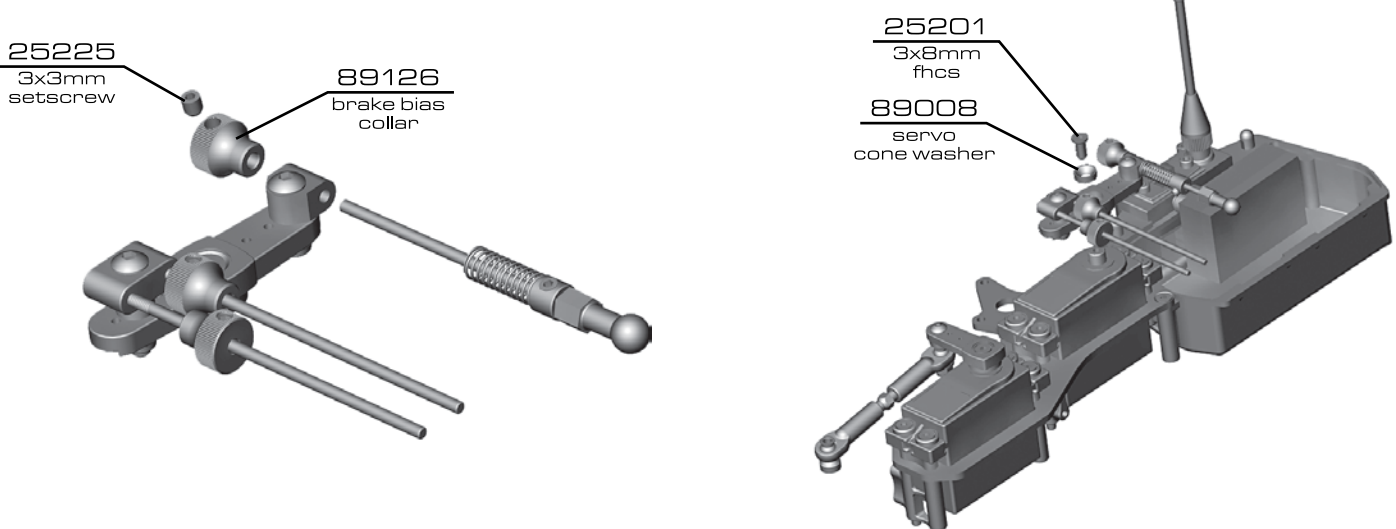

:: Radio Tray (cont.)

receiver pack configurations

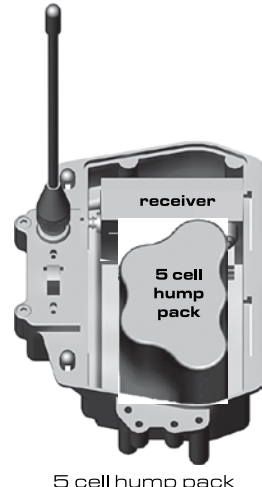
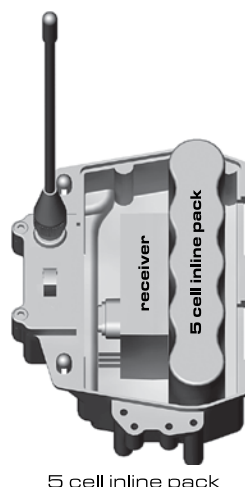
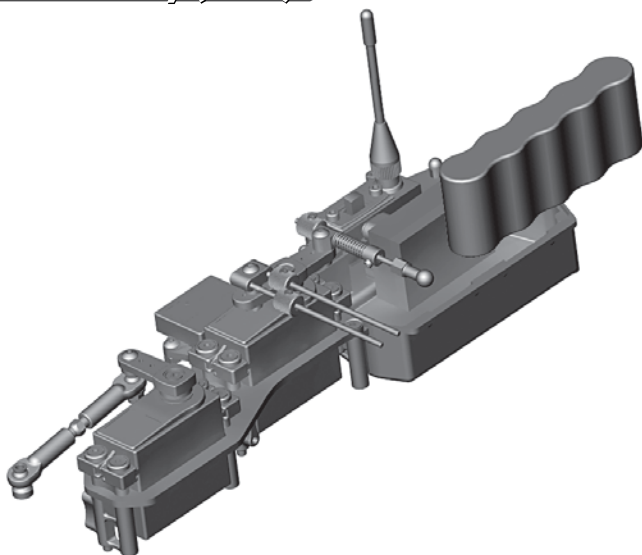

4 cell AA pack

5 cell inline pack

5 cell hump pack



## :: Radio Tray (cont.)

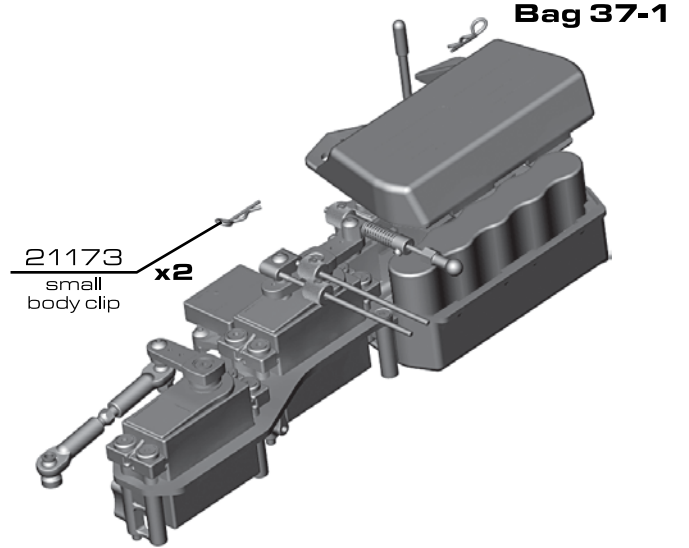
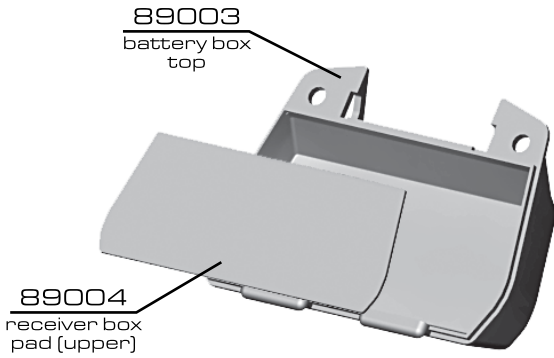

## :: Engine

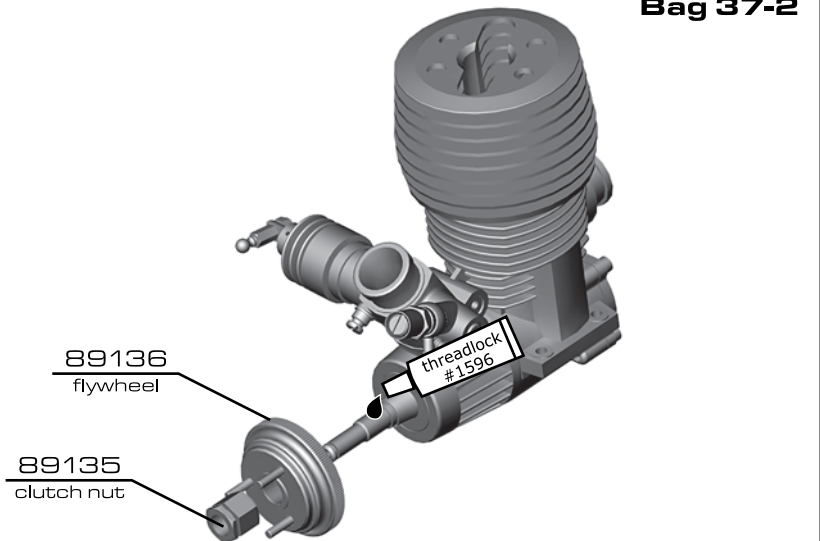
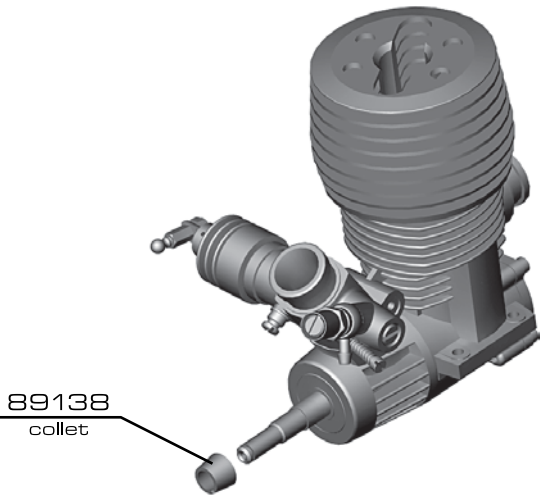

## :: Engine (cont.)

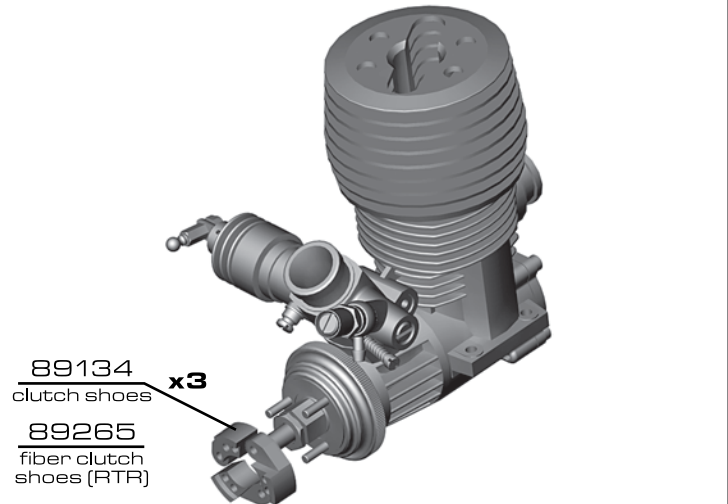
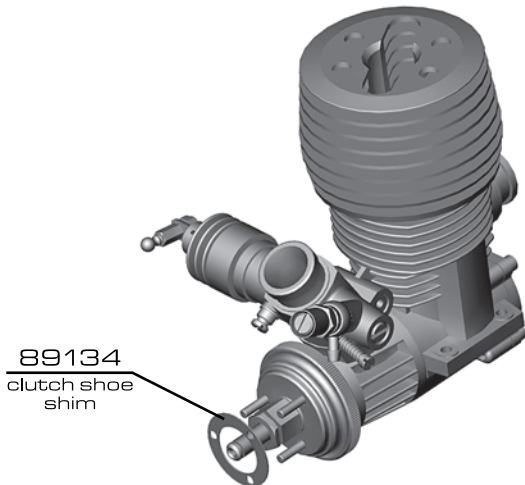

:: Engine (cont.)

Bag 38-1

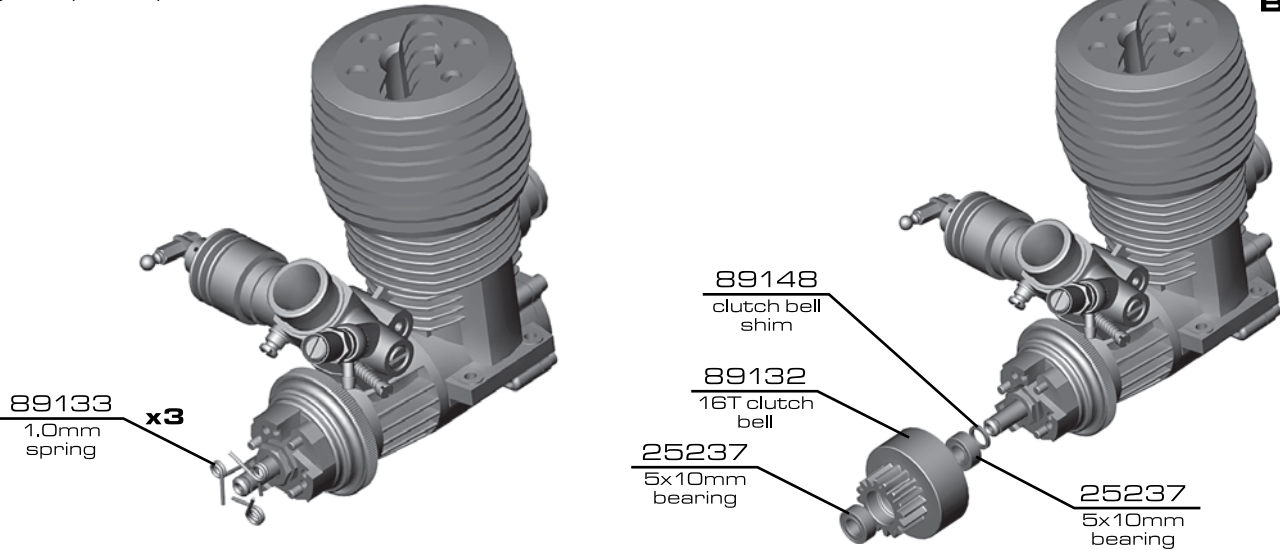

:: Engine (cont.)

Bag 38-2

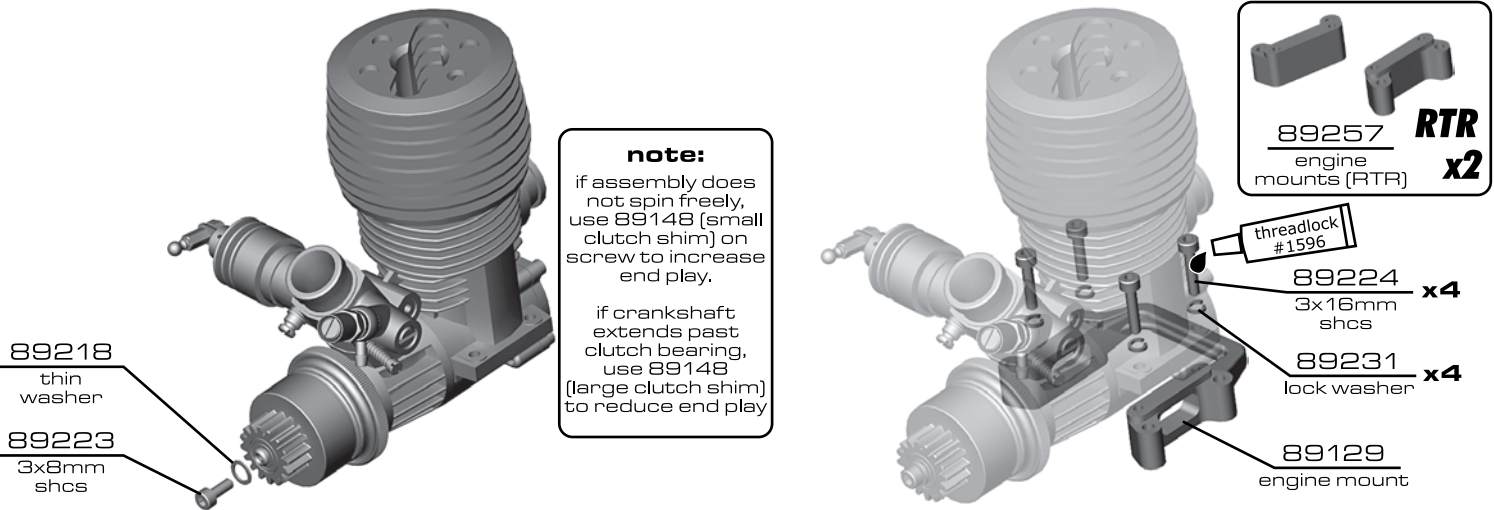

:: Engine (cont.)

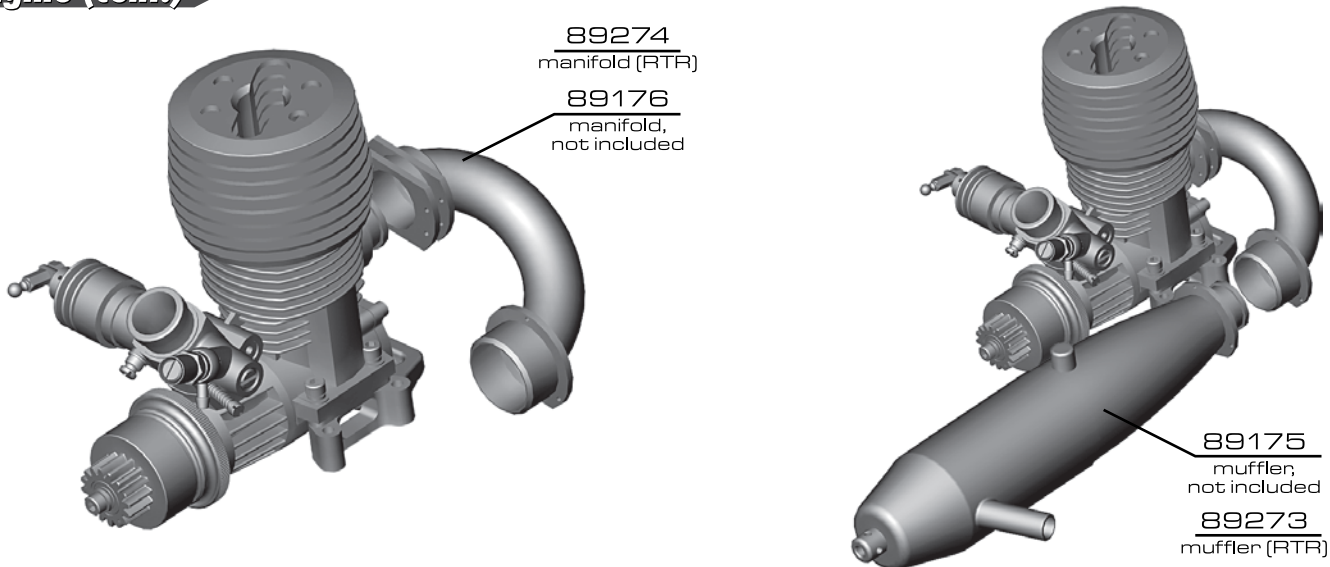

## :: Radio Tray Assembly

Bag 39-1

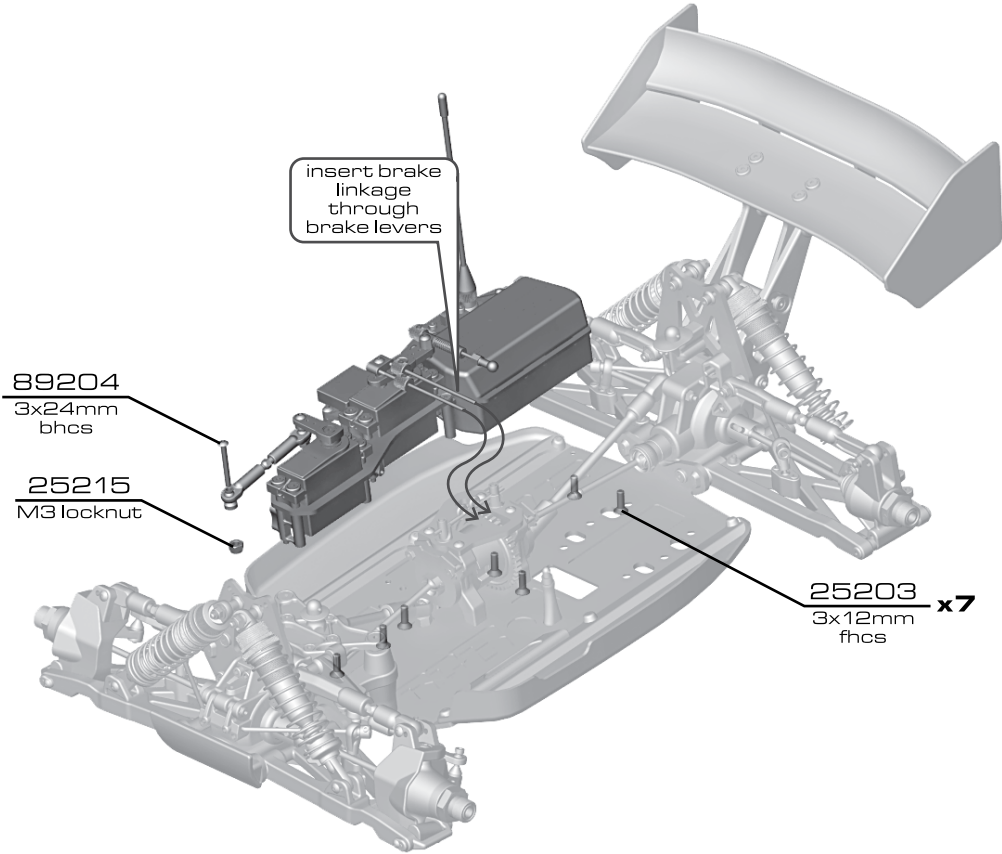

## :: Radio Tray Assembly (cont.)

Bag 39-2

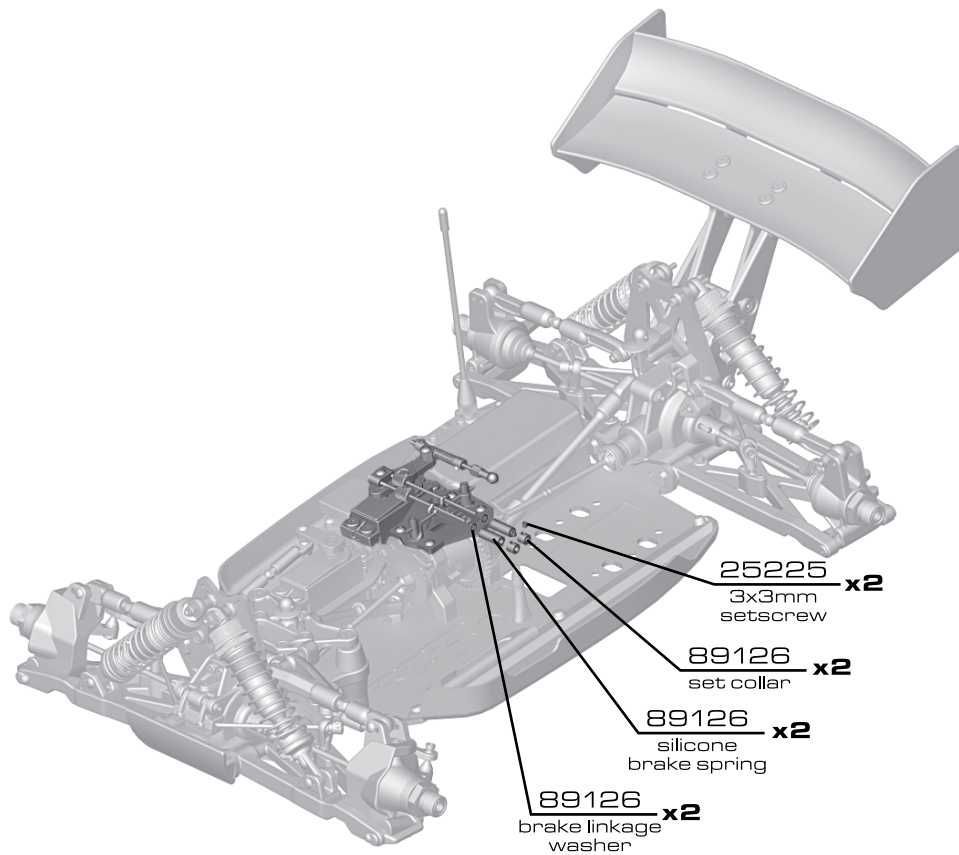



**:: Engine Assembly**

Bag 40-1

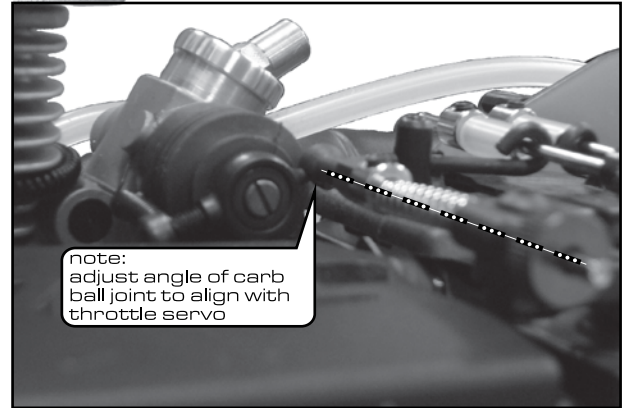
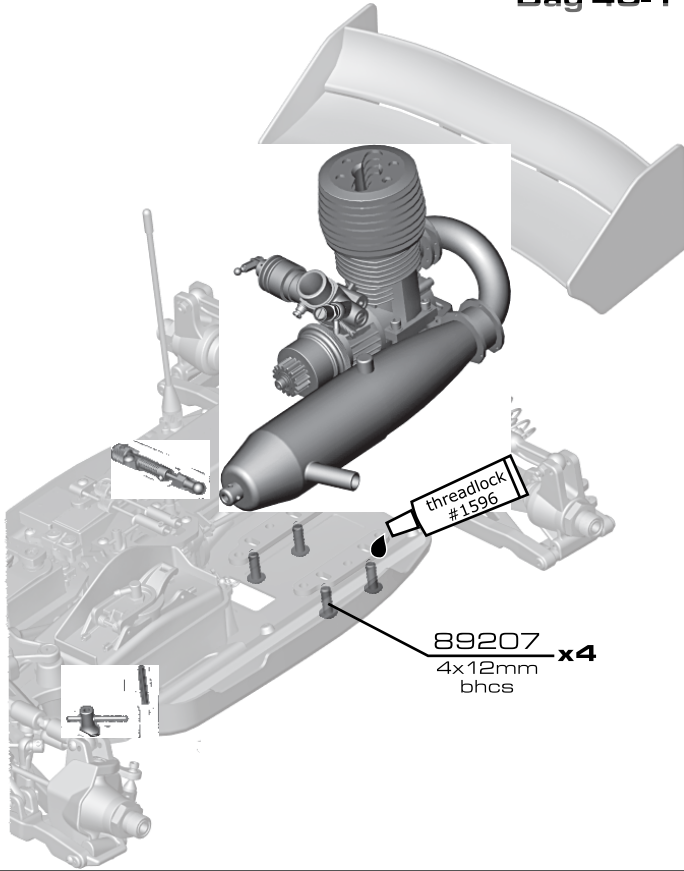

**:: Linkage Adjustment**

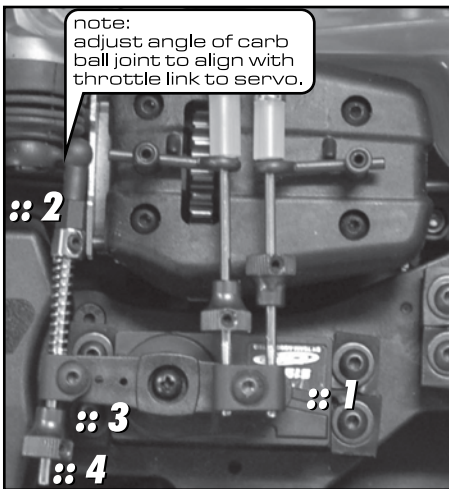

- 1: turn on transmitter and car; adjust servo horn until position is parallel with centerline at neutral.
- 2: set pre-load on spring so that throttle will close.
- 3: set .05mm gap on throttle collar.
- 4: trim off excess rod.

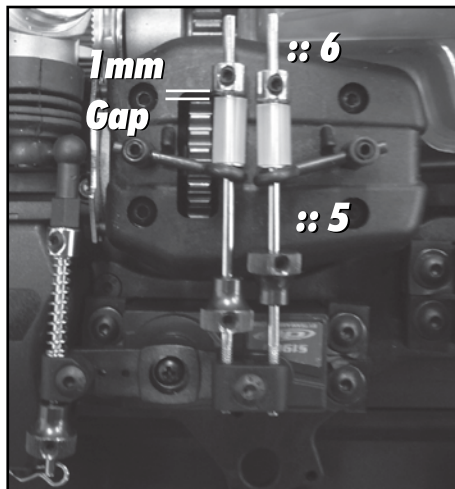

- 5: pull cams to engage brakes. set collar (with brakes engaged) to have 1 mm gap between tubing and collar; remember: transmitter is still on during this step.
- 6: trim off excess brake link wire.

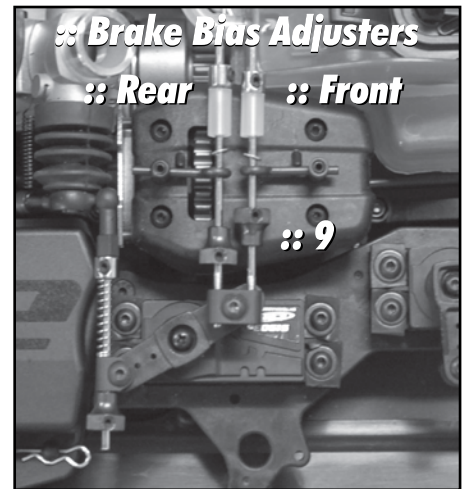

- 7: set throttle EPA max. apply full throttle on transmitter and set EPA so that the carb is full open. be careful not to over-extend the carb.
- 8: set max brake EPA at 30% as a starting point.
- 9: brake bias adjusters: thread the adjuster into the mount to achieve stronger brakes on that end of the car.

**!DO NOT START ENGINE FOR THIS STEP!**



## :: Filter Assembly

Bag 41-1

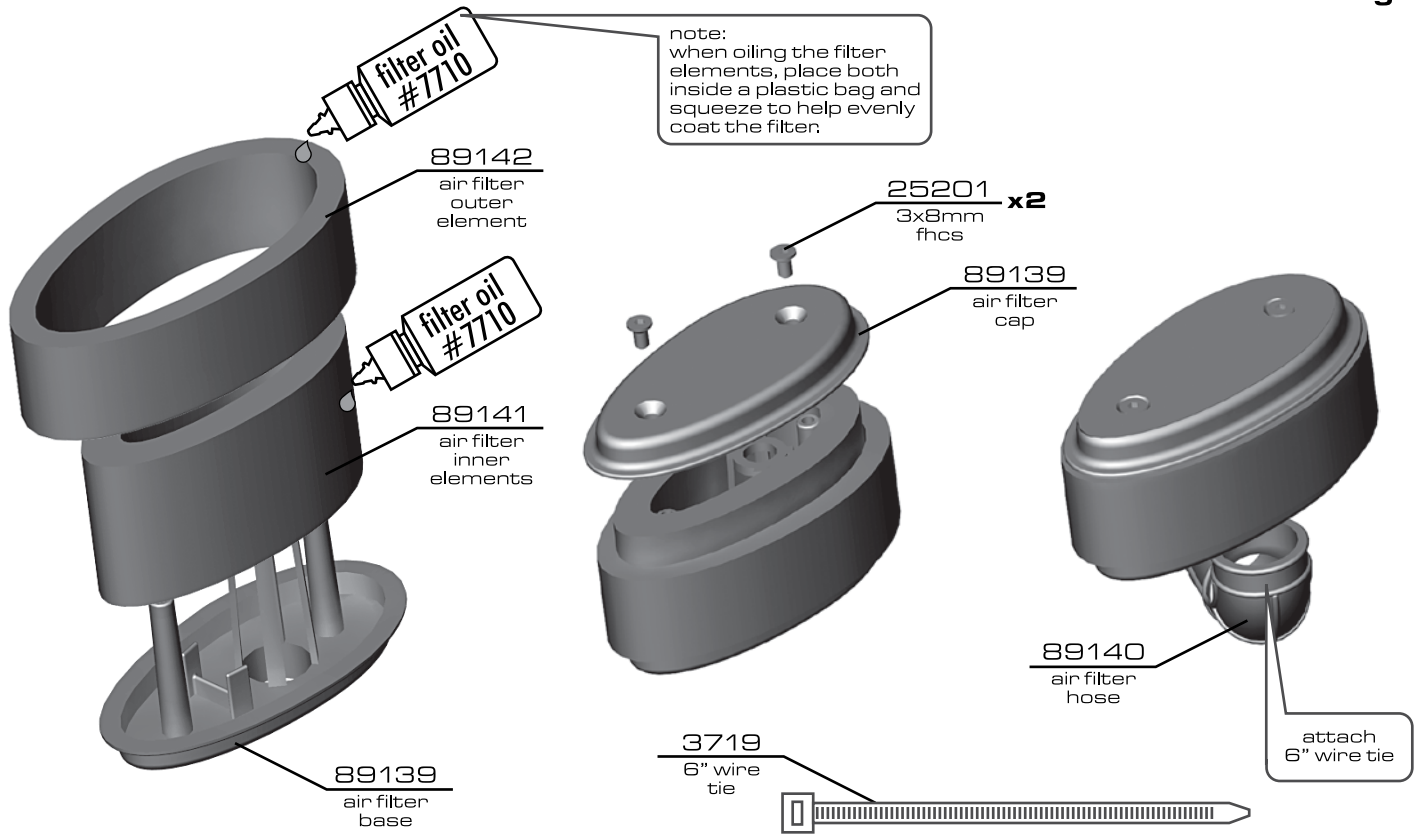

## :: Filter Assembly (cont.)

Bag 41-1

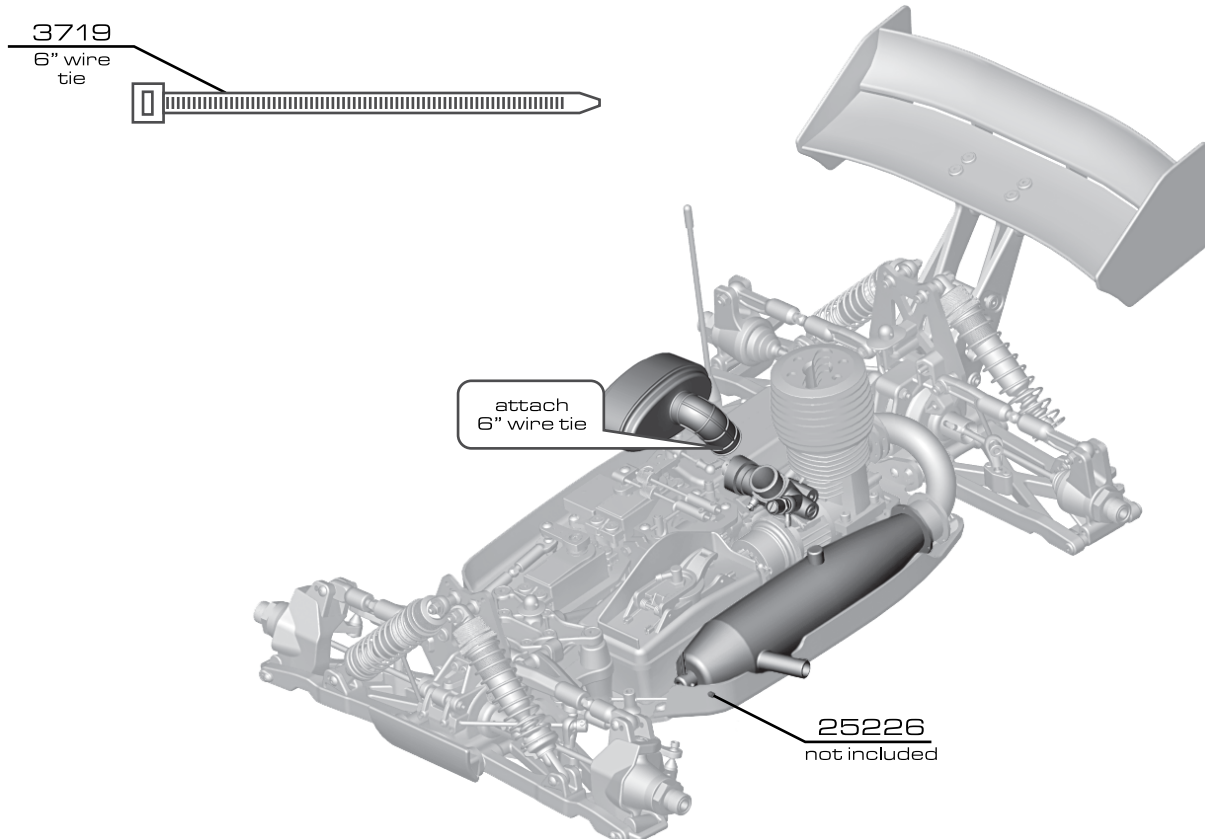

:: Fuel Line

—————  
pressure line  
from fuel tank lid to  
exhaust pipe nipple

.....  
fuel line  
from fuel tank to  
carburetor

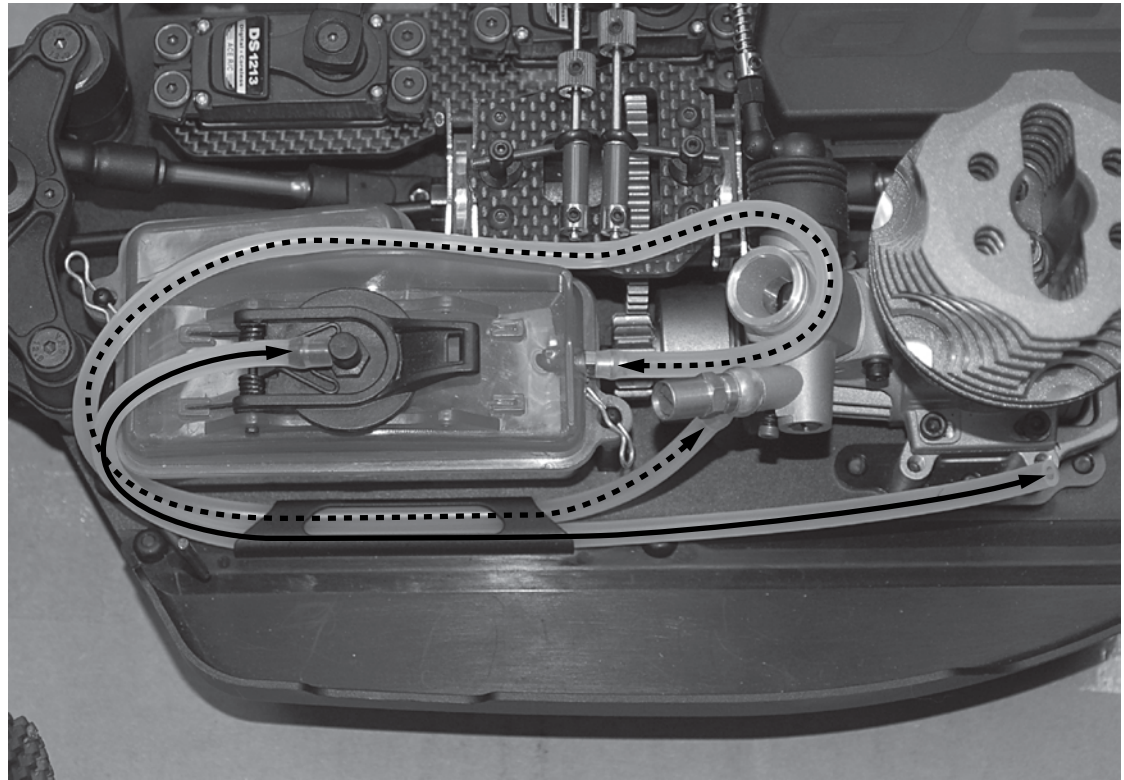

:: Tire Assembly

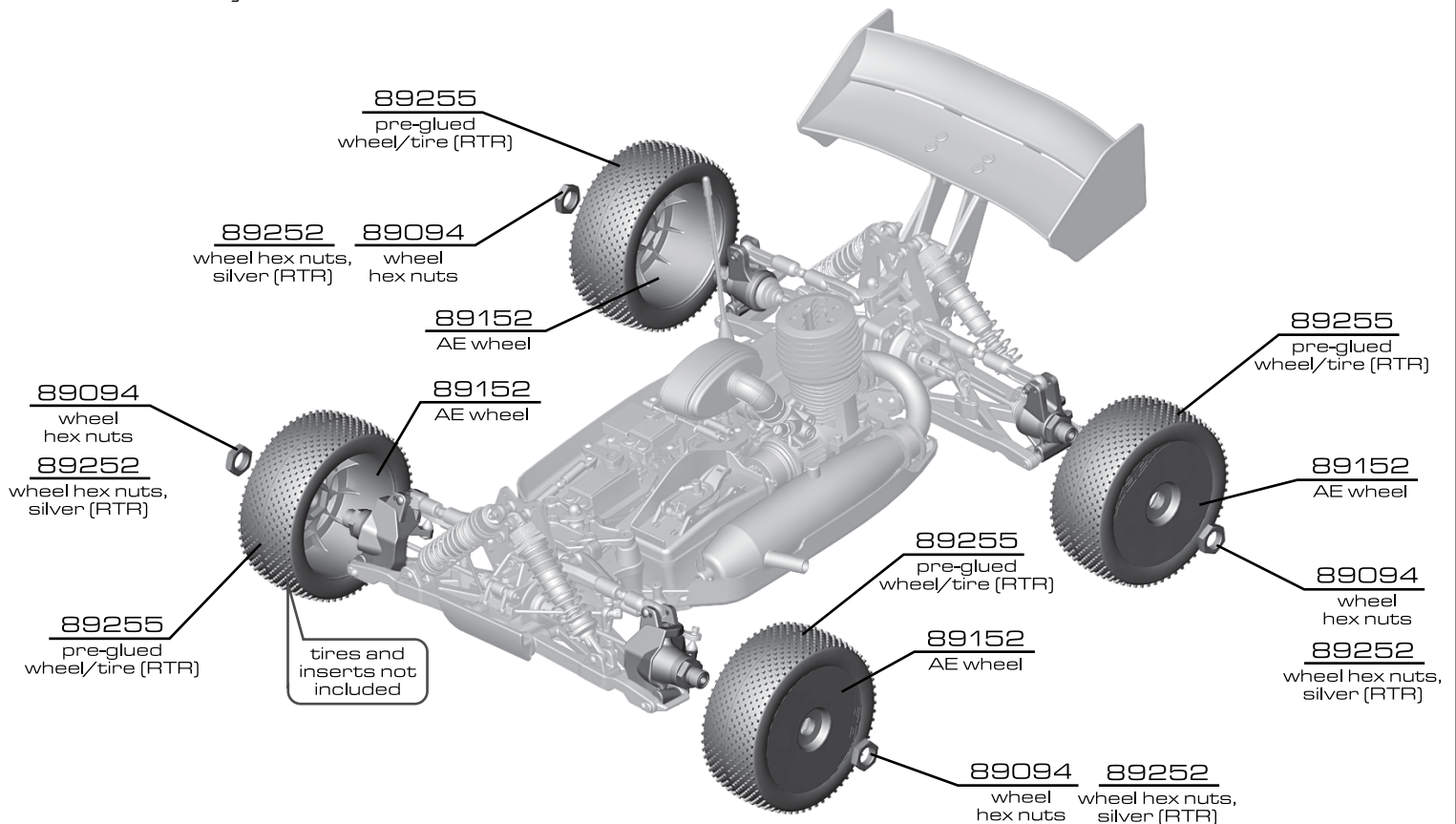

## :: Body Assembly

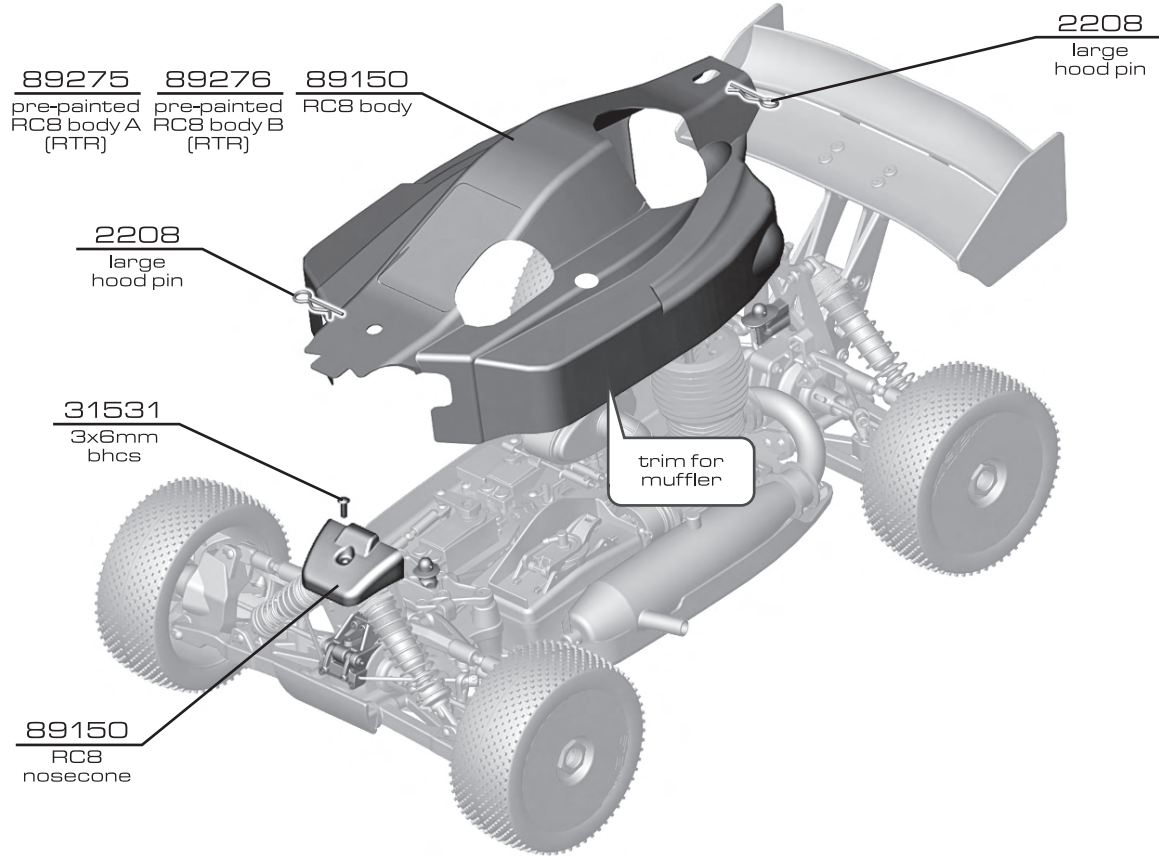

## :: Building Tips

### Tires:

The tires need to be glued to the wheels using any fast-curing cyanoacrylate glue (CA) [AE Pt# 1597]. This is available at your local hobby shop. Make sure to clean the mounting surface of the tire with alcohol for best adhesion

### Gear Mesh:

To correctly set your gear mesh, follow the steps below:

1. Loosen engine mount screws so you can slide your engine and mount.
2. Slide engine and mount until the clutchbell gear comes in contact with the spur gear. Tighten engine mount screws. Hold the spur gear in place and 'rock' the clutchbell gear. There should be a little 'free-play' between the gears.
3. If you have a small amount of 'free-play', continue building your RC8. If not, go back to Step 1.

### Receiver Pack:

Your RC8 does not come with a receiver pack. It is recommended that you use a 5-cell 1000mah pack (minimum) in either stick [AE Pt #614] or hump [AE Pt#615] pack configuration (your RC8 will accept either). Charge your pack per the battery manufacturer's instructions. This will need to be done before you can setup up your RC8.

### Engine Tuning:

Follow the manufacturers instructions to correctly tune your engine. You will need to adjust the fuel mixture according to altitude, weather, etc.

### Body (Factory Team only):

Your RC8 comes with a clear lexan body. You will need to prep the body before you can paint it. Wash the inside thoroughly with warm water and liquid detergent. Dry using a clean, soft, lint-free cloth. Use the supplied window masks to cover the windows from the **INSIDE** (RC cars get painted from the inside). Using high quality tape, apply to create a design to the inside of the body. Spray (either can or airbrush) the paint to the inside of the body (**NOTE: use ONLY paint that is recommended for use with lexan (polycarbonate) plastics. If you don't, you will destroy the plastic body!!!!**).

After painting, cut the body along the trim lines. Make sure to cut holes for the engine head, body mounts, antenna, fuel tank lid, top end adjustment needle and muffler outlet



**:: Tuning****Gearing:**

Recommended Gearing: 16-44

For larger outdoor tracks the Team will typically go up to a 17 tooth clutchbell.

**Differential Fluid:**

Standard differential fluid setup: Front= 5,000 CST; Center= 7,000 CST; Rear= 3,000 CST.

**Front Differential:**

Use the standard setup for most cases, but for higher grip tracks try 7,000 or 10,000 CST for less low speed steering and better acceleration out of turns.

**Center Differential:**

Use the standard setup for most cases, but for higher grip tracks try thicker oil (7,000 or 10,000 CST) for harder acceleration out of turns. For bumpy or low grip tracks, try lighter oil (5,000 or 3,000 CST). The most popular settings are 5000 and 7000 CST.

**Rear Differential:** The most popular settings are 3000 and 5000 CST. The thicker oil will rotate less in the turns and accelerate straight on power.

**Caster:**

The supplied caster block inserts are 16 degrees. Standard kickup is 7 degrees for a total caster of 23 degrees. You can reduce caster to 14 degrees for smoother steering (also adjust upper caster spacing with both shims in front the ball joint) and up to 18 degrees for more steering (also adjust upper caster spacing with both shims behind of the ball joint).

**Front Upper Pivot Insert:**

The standard insert is the middle location (1 dot). Going up (2 UP, 3UP - 1 mm each) will give more middle and exit steering. Going down (2 DOWN, 3 DOWN) will reduce steering.

**Front Caster Block Location:**

The standard inner location will work the best for most tracks. Going to the longer link will give more mid to exit steering, but can make the car less stable in bumps and exiting turns.

**Steering Rack Location:**

The standard middle location will work the best for most tracks. Going to the back hole will give the car more aggressive steering, especially off-power at low speed. Going to the front hole will give more steering, especially noticeable on power through faster sweeping turns.

**Front Camber:**

A good starting camber setting is -2 degrees. Positive camber, where the top of the tire is leaning out, is typically not recommended.

**Front Toe-In:**

Zero degree toe-in (tires pointing straight forward) is a good starting setting. You can increase turn in by adding a little toe-out (front of tires point slightly out). Front toe in is not a typical tuning adjustment used by The Team.

**Front Ride Height:**

The front ride height setting you should use most often is with 5.3 mm pre-load on the threaded collars (or about 27-29 mm of gap between the chassis bottom and ground). The front arms should look above level and the driveshafts level from the front view. As a starting point, set the front end so that the chassis is level from the side view. Check the ride height by lifting up the entire car about 8-12 inches off the bench and drop it. After the suspension "settles" into place, then raise or lower the adjustment collars as necessary.



**:: Tuning (cont.)****Anti-squat:**

Anti-squat denotes the angle of the rear arms relative to the ground. The kit setting is 2 degrees, and you can also run 1 degree by changing to 3 DOWN insert in front of the rear gearbox. Run the 1 dot insert to get 3 degrees of anti-squat.

---

**Rear Camber Link Length & Vertical Adjustment:**

On the RC8 you can change the length of the camber link on the hub, or adjust the inboard location on the tower.

The kit setting is the best compromise of cornering grip and acceleration. From the kit setting, lowering the tower location will square up more and slide more predictably.

Lengthening the camber link on the hub will give the feeling of more rear traction but may be less predictable when it breaks loose.

---

**Rear Hub Spacing:**

You have 3 options for rear hub spacing, FWD, MIDDLE, & BACK. The kit setting provides a good balance of rear traction and steering, and will be used most often. Moving the hubs FWD will give more rear traction for low grip tracks. You can use the hubs BACK on high grip tracks. Also, you can replace the included shims to get intermediate settings.

---

**Rear Camber:**

A good starting camber setting is -2 degrees. Use the included # 1719 camber gauge to set your camber. Adding a small amount of positive camber, where the top of the tire is leaning out, will tend to improve straight-line acceleration on loose tracks.

---

**Rear Ride Height:**

The rear ride height setting you should use most often is with 6.4 mm pre-load on the threaded collars (or about 27-29 mm of gap between the chassis bottom and ground). The rear arms should look level or slightly above from the rear view. As a starting point, set the front end so that the chassis is level from the side view. Check the ride height by lifting up the entire car about 8-12 inches off the bench and drop it. After the suspension "settles" into place, then raise or lower the adjustment collars as necessary.

---

**Setup Sheets:**

Most often, the best way to get your car handling right is to go to our web site [www.rc10.com](http://www.rc10.com) and click on the links to Setup Sheets, then RC8 setups. Our team of professional drivers help develop these setups at National events. Also, most drivers have a "base" setup that they use as a starting point for every event. Try running some of our base setups OR look for track conditions and tires that are similar to your local track and mimic that setup. Remember, each adjustment has a purpose, so copy everything from the setup sheet and then make adjustments based on the recommendations in here and in our online tuning guide at <http://www.rc10.com/rc/tuning>.

## Setup Sheet for Team Associated's RC8

Rev. 2

### :: Front Suspension

anti-roll bar:  
 2.2 - black  
 2.5 - silver  
 2.8 - gold

kickup bushing  
 # 2  
 up  down

steering rack:  
 back  
 mid  
 front

hinge pin bushing  
 # 1  
 up  down

camber: -2 °  
 caster: 16 °  
 toe: 0 °  
 ride height: 27 mm

### :: Rear Suspension

anti-roll bar:  
 2.2 - black  
 2.5 - silver  
 2.8 - gold

anti-squat bushing  
 # 2  
 up  down

wheelbase:  
 long  
 medium  
 short

camber: -2 °  
 ride height: 27 mm

### :: Front Shocks

spring: 70 rate      piston: 1.6  
 shock fluid: 50 wt.      length: full 108mm

### :: Rear Shocks

spring: 59 rate      piston: 1.6  
 shock fluid: 40 wt.      length: full 125mm

### :: Differentials

front fluid: 5000cst  
 center fluid: 7000cst  
 rear fluid: 3000cst

### :: Wing

location:  forward  back  
 angle:  low  med.  high  
 type: standard

### :: Notes

### :: Engine

engine: \_\_\_\_\_ restrictor: \_\_\_\_\_  
 muffler: \_\_\_\_\_ temp: \_\_\_\_\_  
 glow plug: \_\_\_\_\_  
 fuel: 30% recommended

### :: Gearing/Clutch

gearing: 16/44  
 clutch shoes: standard  
 clutch spring:  .9mm  1.0mm  1.1mm  
 other: \_\_\_\_\_

### :: Front Tires

tire: \_\_\_\_\_  
 compound: \_\_\_\_\_  
 insert: \_\_\_\_\_  
 wheel: \_\_\_\_\_

### :: Rear Tires

tire: \_\_\_\_\_  
 compound: \_\_\_\_\_  
 insert: \_\_\_\_\_  
 wheel: \_\_\_\_\_

### :: Race and Vehicle Comments







qualify: \_\_\_\_\_ main: \_\_\_\_\_ finish: \_\_\_\_\_ tq:   
 comments: \_\_\_\_\_  
 \_\_\_\_\_  
 \_\_\_\_\_  
 \_\_\_\_\_

### :: Track Info







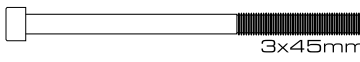

smooth:  bumpy:  blue groove:   
 traction:  high  med.  low  
 soft dirt:  grass:  clay:  wet:   
 dusty:  other: \_\_\_\_\_  
 \_\_\_\_\_  
 \_\_\_\_\_

## :: Hardware - 1:1





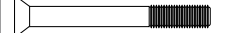

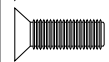





### cap head (shcs)

	2.5x8mm (89222)
	3x8mm (89223)
	3x10mm (25620)
	3x16mm (89224)
	3x20mm (25192)
	3x24mm (89225)
	3x26mm (89226)
	3x45mm (89279)

### flat head (fhcs)

	3x8mm (25201)
	3x10mm (25202)
	3x12mm (25203)
	3x14mm (89208)
	3x18mm (89209)
	3x20mm (89210)
	3x26mm (89211)
	3x30mm (89212)
	4x6mm (89213)
	4x12mm (89214)



### button head (bhcs)

	2.5x3mm (89201)
	2.5x6mm (31520)
	3x6mm (31531)
	3x10mm (25211)
	3x12mm (89202)
	3x14mm (25187)
	3x16mm (89203)
	3x18mm (2308)
	3x20mm (25188)
	3x24mm (89204)
	3x26mm (89205)
	4x10mm (89206)
	4x12mm (89207)

### setscrews

	3x3mm (25225)
	3x5mm (89219)
	4x3mm (89106)
	4x5mm (25226)
	4x12mm (89220)
	5x4mm (89221)

### ball bearings

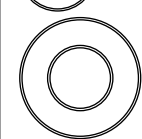
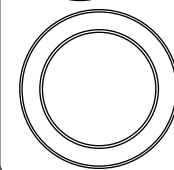
	steering bearing (89161)
	5x10mm (25237)
	6x10mm (31404)
	8x16mm (25236)
	15x21mm (89162)

### nuts (lock/plain)

	m3 locknut (25215)
	m4 locknut (89216)

### shims & washers

	thin washer (89218)
	clutch bell shims (89148)
	diff washer (89120)
	diff shim (89117)

### notes

**Setup Sheet for Team Associated's RC8**

**Rev. 2**

**:: Front Suspension**

anti-roll bar:  
 2.2 - black  
 2.5 - silver  
 2.8 - gold

kickup bushing  
 # \_\_\_\_\_  
 up  down

steering rack:  
 back  
 mid  
 front

hinge pin bushing  
 # \_\_\_\_\_  
 up  down

camber: \_\_\_\_\_  
 BA

caster: \_\_\_\_\_

toe: \_\_\_\_\_

ride height: \_\_\_\_\_ mm

**:: Rear Suspension**

anti-roll bar:  
 2.2 - black  
 2.5 - silver  
 2.8 - gold

anti-squat bushing  
 # \_\_\_\_\_  
 up  down

wheelbase:  
 long  
 medium  
 short

camber: \_\_\_\_\_  
 BA

ride height: \_\_\_\_\_ mm

**:: Front Shocks**

spring: \_\_\_\_\_ piston: \_\_\_\_\_  
 shock fluid: \_\_\_\_\_ length: \_\_\_\_\_

**:: Rear Shocks**

spring: \_\_\_\_\_ piston: \_\_\_\_\_  
 shock fluid: \_\_\_\_\_ length: \_\_\_\_\_

**:: Differentials**

front fluid: \_\_\_\_\_  
 center fluid: \_\_\_\_\_  
 rear fluid: \_\_\_\_\_

**:: Wing**

location:  forward  back  
 angle:  low  med.  high  
 type: \_\_\_\_\_

**:: Notes**

\_\_\_\_\_  
 \_\_\_\_\_  
 \_\_\_\_\_

**:: Engine**

engine: \_\_\_\_\_ restrictor: \_\_\_\_\_  
 muffler: \_\_\_\_\_ temp: \_\_\_\_\_  
 glow plug: \_\_\_\_\_  
 fuel: \_\_\_\_\_

**:: Gearing/Clutch**

gearing: \_\_\_\_\_  
 clutch shoes: \_\_\_\_\_  
 clutch spring:  .9mm  1.0mm  1.1mm  
 other: \_\_\_\_\_

**:: Front Tires**

tire: \_\_\_\_\_  
 compound: \_\_\_\_\_  
 insert: \_\_\_\_\_  
 wheel: \_\_\_\_\_

**:: Rear Tires**

tire: \_\_\_\_\_  
 compound: \_\_\_\_\_  
 insert: \_\_\_\_\_  
 wheel: \_\_\_\_\_

**:: Race and Vehicle Comments**

qualify: \_\_\_\_\_ main: \_\_\_\_\_ finish: \_\_\_\_\_ tq:   
 comments: \_\_\_\_\_  
 \_\_\_\_\_  
 \_\_\_\_\_  
 \_\_\_\_\_

**:: Track Info**

smooth:  bumpy:  blue groove:   
 traction:  high  med.  low  
 soft dirt:  grass:  clay:  wet:   
 dusty:  other: \_\_\_\_\_  
 \_\_\_\_\_  
 \_\_\_\_\_