

# UL-1 **SUPERIOR**

**WARNING:**

- Never attempt to swim after a stalled R/C boat.
- Never operate your R/C boat while standing in the water.
- Never operate your R/C boat in the presence of swimmers.
- Always use a Personal Flotation Device (PFD) when boarding and operating your retrieval craft, i.e. Jon boat or duck boat.  
NOTE: Because of the sharp running hardware included with this R/C boat, we do not recommend a rubber blow up raft.
- R/C boat running hardware is very sharp. Be very careful when working on and around the metal parts.
- While the motor is running pay close attention to the propeller. Do not come in contact with the propeller at any time the engine is running or serious injury will result.
- AquaCraft products are to be used by ages 14 and over.



**CAUTION:** The performance of this RC boat is not for the faint of heart! Out of the box speeds can reach 40 MPH. Your full attention must be maintained while operating this product.

## ITEMS INCLUDED



UL-1 Hull, Canopy, Cowl, Vertical Wings (Installed)  
Transmitter, Manual, Boat Stand

## WARRANTY

AquaCraft will warrant your UL-1 Superior for 90 days after the purchase from defects in materials or workmanship of original manufacture. AquaCraft, at their option, will repair or replace at no charge, the incorrectly made part. This warranty does not cover damage caused by crash, abuse, misuse, alteration or accident. To return your boat for repairs you need to provide proof of purchase. Your store receipt or product invoice will suffice. IN NO EVENT SHALL THE PURCHASER BE ENTITLED TO ANY INCIDENTAL, SPECIAL, INDIRECT OR CONSEQUENTIAL DAMAGES, WHETHER RESULTING FROM THE USE, MISUSE OR INABILITY TO USE THE PRODUCT OR FROM DEFECTS IN THE PRODUCT. This warranty gives you specific legal rights and you may also have other rights, which vary from state to state. (Outside USA and Canada, contact local importer for warranty information.)

Hobby Services  
3002 N. Apollo Drive, Suite 1  
Champaign, Illinois 61822  
Attn: Service Department  
Phone: (217) 398-0007  
9:00 am - 5:00 pm Central Time M-F  
E-mail: [hobbyservices@hobbico.com](mailto:hobbyservices@hobbico.com)

### **STANDARD REPAIR SERVICE**

After the 90-day warranty has run out, you can still have your UL-1 Superior repaired for a service fee by the experts at AquaCraft. To speed up the repair process, please follow these four simple steps:

**Important Note:** For standard repair service you must specify whether you wish the charges to be billed COD or if you wish to be notified of the charges so you can send a check.

1. Please return the ENTIRE system, boat and radio.
2. Make sure batteries are removed from the transmitter.
3. Send written instructions which include a list of all items returned, a THOROUGH explanation of the problem or problems of the service needed. Be sure to include your return address and daytime phone number. If you have access to e-mail please provide us with your e-mail address to help speed communication.
4. Send to the address above.

## INTRODUCTION

Thank you for purchasing the AquaCraft™ UL-1 Superior! We want the time you spend with your new R/C boat to be fun and successful so please fully read the manual. If for any reason you think this R/C model is not for you, return it to your local hobby dealer immediately. Your hobby dealer cannot accept returns on any model after final assembly or after your boat has been operated.

## SAFETY PRECAUTIONS

- **Never, ever, attempt to swim after a stalled R/C boat. Do not get in the water for any reason to retrieve your boat. To aid you in retrieving a stalled R/C boat, set up a fishing reel with a tennis ball tied to the end of the line. Or better yet, get yourself a small boat so you can row out and pick up your R/C boat. Remember to use a PFD any time you enter your retrieval craft.**
- AquaCraft products are to be used by ages 14 and over.
- Do not touch the propeller anytime the motor is spinning. Pay equally close attention to items such as loose clothing, shirtsleeves, ties, scarves, long hair or anything that may become entangled in the spinning prop. If your fingers, hands, etc. come in contact with the spinning propeller, you may be severely injured.
- The speed and mass of this boat can inflict property damage and severe personal injury if a collision occurs. Never run this boat in the presence of swimmers or where the possibility of collision with people or property exists.
- This boat is controlled by radio signals, which are susceptible to possible interference.
- If your UL-1 should happen to stall, water currents will slowly carry it to shore. The bad news is that the boat could be carried to the opposite shore. When surveying areas to run your model, keep variables in mind such as wind direction, size of the lake, etc. It is not advisable to run R/C boats on any free-flowing bodies of water such as creeks or rivers.

## FEATURES & SPECIFICATIONS

### UL-1 SUPERIOR FEATURES:

- Realistic looks and modern UL (Unlimited Light) style details.
- Lightweight painted fiberglass and ABS construction.
- Tactic 2.4GHz radio system.
- New AquaCraft 36-56-2030KV 6 pole motor.
- 60AMP water cooled ESC with 12 Volt stutter bump warning system and 11.6volt battery cut off.
- Center "drop tub" interior.
- Direct water contact aluminum motor cooling jacket.
- Special GrimRacer 2mm thick aluminum turn fin.
- Black anodized aluminum hardware.
- FE Racing inspired waterproof tape down hatch system.
- Magnetic cowl locking system.
- Break away vertical fins.
- Heavy duty steering pushrod.

### UL-1 SUPERIOR SPECIFICATIONS:

Hull Length: 27" (685mm)  
Overall Length: 29-1/4" (744mm)  
Width: 14-1/4" (360mm)  
Overall Height: 6-3/4" (170mm)  
Weight (Less Batteries): 4lbs, 1oz  
Weight RTR (with two 3200 LiPo): 4lbs, 14oz

### MOTOR SPECIFICATIONS:

Diameter: 36mm  
Length: 56mm  
Shaft Length: 15mm  
OA Length: 71mm  
Shaft Size: 5mm  
Weight: 212g including connectors  
Input Voltage: 7-18.5V  
Max. Constant Current: 50A  
Max. Surge Current: 80A/five seconds  
No Load Current: 5.0A  
kV Rating: 2030 rpm/V

### ESC SPECIFICATIONS:

Length: 3.25" (83mm)  
Width: 1.5" (38mm)  
Height: 5/16" (17mm)  
Weight: 3.8oz (109grams)  
Wire Gauge: 14g  
Battery Connectors: Male Ultra Deans Plugs (2)  
Motor Connectors: 4mm gold plated bullet connectors (3)  
Input Voltage: 12-14 NiMH  
4 cells LiPo  
8-20V input w/o BEC)  
Output Current: 60A continuous maximum  
(72A surge maximum)  
Max Output Power: 720 watts  
On-resistance: 0.003 ohms  
Operating frequency: 8kHz  
BEC: 5.2V/2A  
Stutter Bump Voltage: 12V  
Low Voltage Cutoff: 11.6V  
Thermal Cutoff: 110°C  
Timing Angle: 10°

## MANUAL SPECIFICATION AND DESCRIPTION CHANGES

All pictures, descriptions, and specifications found in this instruction manual are subject to change without notice. AquaCraft maintains no responsibility for inadvertent errors in this manual.

## ITEMS NEEDED TO COMPLETE YOUR UL-1 SUPERIOR

- GPMP0622 Great Planes® ElectriFly™ LiPo 7.4V 3200mAh 20C Power
- GPMM3152 Great Planes ElectriFly Triton™ Jr DC Computer Charger
- GPMM3160 Great Planes ElectriFly Equinox™ LiPo Cell Balancer 1-5
- AQUB9514 AquaCraft GrimRacer Pro Radio Box Tape
- AQUB9500 AquaCraft GrimRacer Speed Grease
- Four "AA" Batteries (Transmitter)

## OPTIONAL ITEMS

NOTE: Your UL-1 Superior requires the batteries be less than 6" [155mm] long. Keep this in mind as you shop for batteries for your UL-1.

- FPWP0337 FlightPower LiPo 7.4V 3300mAh 25C EVO25-33002S Balance
- FPWP0350 FlightPower LiPo 7.4V 4900mAh 25C EVO25-49002S Balance
- GPMM3015 Great Planes PolyCharge™ 4 DC 4 Output LiPo Charger
- GPMM3153 Great Planes Electrifly Triton2™ DC Computer Charger

## HOW TO SELECT THE PROPER BATTERY

One of the very special features of this model boat is its ability to properly and safely use the latest in LiPo battery technology. Your boat will be lighter, faster and handle better using this style of battery. If you do choose to use NiMH battery packs in your UL-1 Superior you will experience a decrease in overall performance.

**WARNING: Please read and heed all warning information that comes with your LiPo batteries.**

Your UL-1 is designed to use two 7.4V LiPo packs. A 7.4 volt LiPo battery pack is typically called a 2S pack, 2S meaning two cells in series. Our UL-1 is designed to use two 2S packs. The ESC connects the two 2S packs into a total of 4S or four (4) cells in series for a total voltage supply of 14.8V.

**IMPORTANT:** You are going to need to purchase batteries that will be able to supply at least 60 amps average. If you multiply the mAh (capacity) of the battery by the C (current) rating you can determine the duration amperage the battery.

It's easy. Here's how. Lets do a sample calculation based on the Great Planes Electrifly 7.4V 3200mah 20C LiPo battery (GPMP0622). 3200mAh is really 3.2 milliamps hour (mAh) so,  $3.2 \times 20$  (20 is our C rating on the pack) = 64 amps.

We have up to 64 usable amps average for the duration of our run. Most LiPo batteries will allow the amps (current) to spike above this rating but only for very short periods of time. **DO NOT USE A BATTERY PACK THAT CAN NOT DELIVER THE MINIMUM REQUIRED AMPERAGE.**

Also note that the ESC in your UL-1 is rated at 60AMPs. This is **ULTIMATELY** the AMP rating you **DO NOT** want to exceed regardless of the current rating of the packs. The ESC will handle amperage spikes up in the 70amp range but if operated continually at or above the recommended rating you will damage the ESC. Your UL-1 Superior Hydroplane (in stock configuration) safely draws under the ESC current rating. With higher pitch or oversize propellers your motor and batteries can surpass the rating of the ESC and the ESC can be damaged. **We do not recommend using more than 18 volts in your UL-1 Superior.**

### STORAGE AND SAFETY REGARDING LIPOS:

It's a good idea to charge and store LiPo batteries in a safe area or container. **NEVER** leave your LiPo batteries unattended while charging. A metal surplus ammo box makes a great storage and charge container. A LiPo sack also works quite well.

If you have a bad crash and the battery has seen a hard impact, set it on the ground and let it sit for 20 minutes before charging it and placing it back in your safe storage container.

For best performance and safety, never discharge your LiPos to below 2.9V per cell. Always use a balancer when charging and store your packs fully charged.

If your LiPos sit charged for a long time you might find that running this charge out can cause the stutter warning system to kick in during the first minute or so of the run. It's a good idea to cycle your batteries the day before to reach maximum power from the batteries.

## EXTRA SUPPLIES

As with any hobby, it is a good idea to assemble a useful collection of tools and accessories to bring along when you head to the pond. Here are some items you will want to keep handy.

- Extra "AA" Batteries
- Spare prop
- Hobby knife
- Metric Allen Key
- Metric nut drivers
- Servo tape
- Extra hook and loop
- First-Aid kit
- Standard and phillips head screwdrivers
- WD-40 or other water displacing fluid
- Cooler with plenty of ice and water
- Rubber boots
- Paper Towels
- Spray-On Cleaner
- Sunglasses
- Sun block
- Folding table
- Lawn chair
- Canopy or shelter

## COOLING CHECK

Check the cooling system to make sure water can flow through it. You can do this by running water through the cooling system to check for leaks. **It is not uncommon to get a small amount of water in your boat during a run.** The stuffing tube typically allows a small amount of water to enter the boat. If you are finding larger amounts of water in the boat than normal, make sure to re-check the cooling system.



3. Install the provided hook and loop onto your LiPo batteries.

## FINAL ASSEMBLY



1. Slide the cover off the bottom of the transmitter.



2. Install the batteries following the diagram in the bottom of the battery tray.



*Tactic TTX-240*

- 1 ON/OFF Push Button Switch
- 2 Power Light
- 3 Steering Wheel
- 4 Antenna
- 5 Steering Reverse Switch
- 6 Steering Center Knob
- 7 Throttle Center Knob
- 8 Throttle Reverse Switch
- 9 Steering Travel Adjustment Knob
- 10 Throttle Trigger

## START UP

1. Turn on the transmitter, taking note that the power light is illuminated on the transmitter.
2. Stand clear of the propeller and plug each of the main power batteries into the ESC.
3. At this time you will hear one beep. To arm the ESC squeeze the throttle trigger and hold until you hear one more beep. Release the throttle trigger and you will hear three more. Your boat is now ready to operate.

### Review:

Plug in the packs	→	One (1) beep
Squeeze the trigger and hold	→	One (1) beep
Release the trigger	→	Three (3) beeps
Ready to operate		

4. Now is a good time to check the rotation of the prop. Very quickly jab the throttle trigger and check the rotation direction of the motor. It should spin the propeller counterclockwise. If the motor spins the wrong way, simply switch any two of the three wires between the motor and ESC. **WARNING: DO NOT hold the throttle down for more than one or two seconds to check the motor direction or you might risk damaging the motor.**

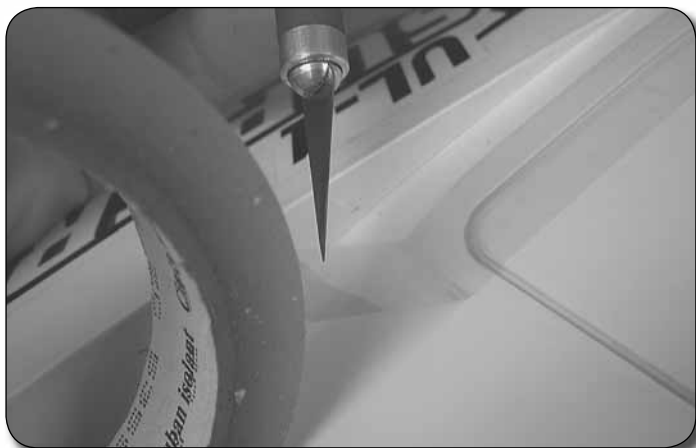

5. Tape the cowl in place carefully, making sure you press it securely down. Make sure you use a good quality hatch tape like GrimRacer Pro Radio Box Tape. Other radio box tapes can leave sticky adhesive that can be hard to remove.

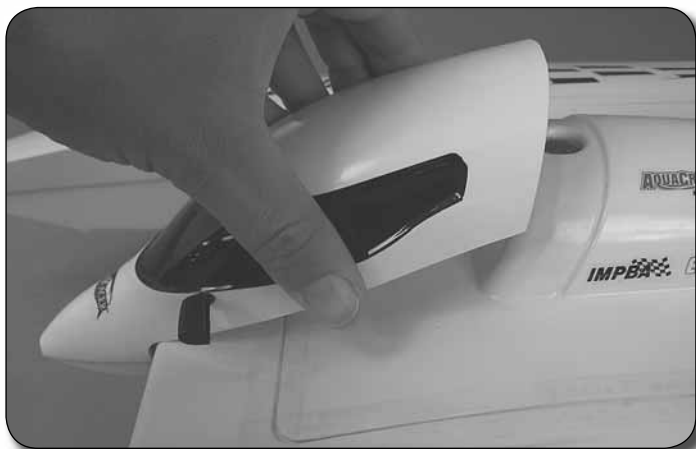

6. Snap the forward canopy in place. Your UL-1 is ready to dominate the water.

## LAUNCHING THE UL-1



You can set the boat still in the water and hit the throttle or hand launch it. The boat is designed to leave using either method. When using the still method, you are going to have to be quite aggressive with the throttle to get the boat on plane but once on step you can back off. Having said this, if you operate your boat at "less than full power" for the full duration of the run, you might likely experience an ESC failure. The extra voltage the batteries deliver is being managed by the ESC and can cause the ESC to get hot enough to fail. When doing a hand launch toss the boat in the water with a forward motion. As the boat hits the water, apply throttle.

Its also good to note that ANY weeds, duck feathers or other obstructions that could get hung up on the running hardware can and will affect the performance of your UL-1. Any extra drag can cause your power system to overheat and do a thermal shut down or possibly fail. It is best to operate your UL-1 in water that is weed free and clear of all obstructions. If your ESC "thermals" in a short time, it will cool and you will be able to re-arm the ESC.

## MAINTENANCE

### SIMPLE MAINTENANCE TIPS:

- After each run remove the drain plug from the transom and drain any water that might have entered the hull.
- Allow the electrics to cool after each run.
- Check your prop for nicks or damage after each run.
- Lightly re-grease the drive cable every 6 or 7 runs.
- After running for the day remove the drive cable and wipe away any water. Lightly re-grease the drive cable and re-install in the boat.
- Spray WD-40 or some other water displacer through the cooling system to prevent any oxidization of the metal parts.
- Clean the exterior of the boat and leave the canopy and cowl off overnight to allow any water to evaporate that might be in the center tub.
- At your earliest convenience re-charge your LiPo batteries and store them in a safe storage container.

## RE-GREASING THE DRIVE SHAFT:



1. You are going to need one 10mm open end wrench and one 12mm open end wrench and some grease.

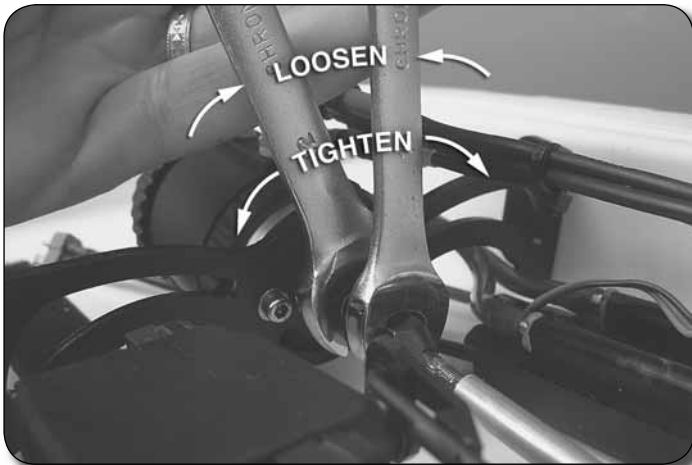

2. To loosen the cable coupler hold the 12mm wrench still and turn the 10mm wrench counterclockwise. To tighten turn the 10mm wrench clockwise.

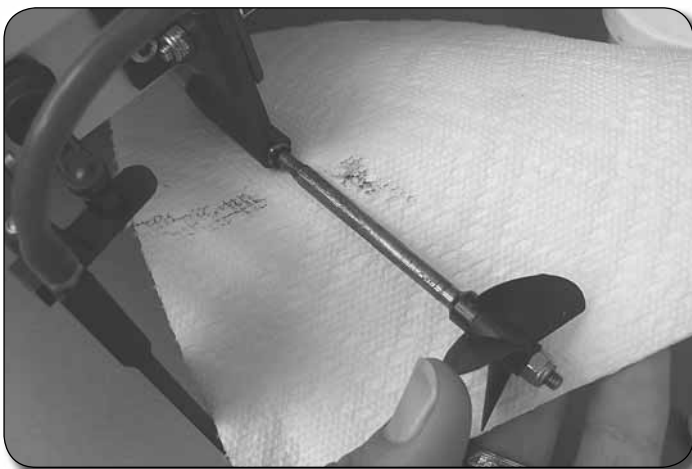

3. Slide the shaft out from the back of the boat and re-grease. Reinstall and retighten the cable.

## TUNING TIPS

**STRUT** – The strut on your UL-1 can be adjusted up and down as well as tilted. To adjust the strut you are going to need to loosen the 4mm bolt that holds the strut in position. When making a strut adjustments you only need to move it a small amount at a time.

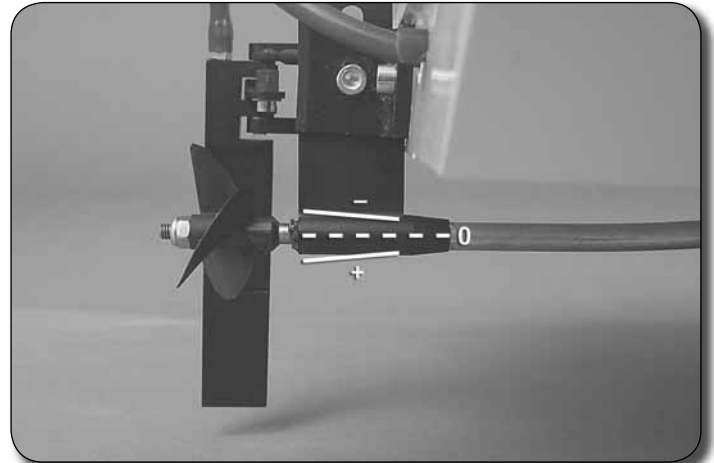

Lowering the strut helps stabilize the boat by lowering the nose of the boat. However, doing so can slow the boat down. Raising the strut has the opposite effect. Tilting the strut is helpful to tune the hull to a particular propeller. If your prop is causing the back of the boat to hop up and down (unhook) try removing or lessening the drive angle. If the boat seems pinned (stuck to the water in the back) try adding some drive angle. I like to adjust the strut to the point the back of the boat just starts to hop and then move the strut back just a small amount to stop it.

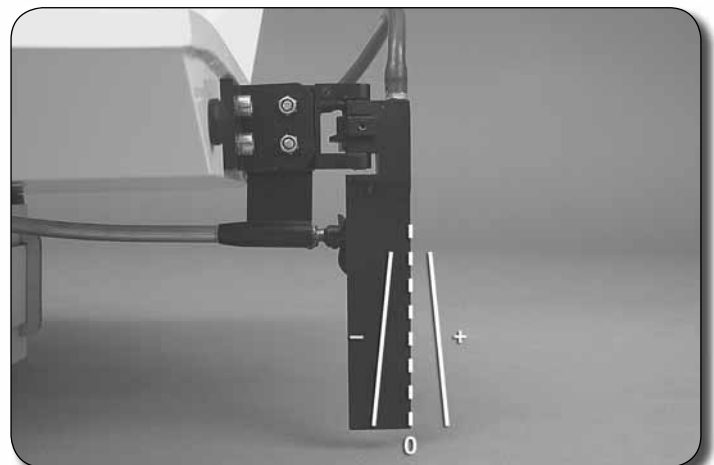

**RUDDER** – You can tilt the rudder fore and aft to change the way the boat handles. The more you tuck the rudder under the boat (negative angle), the tighter the boat runs on the water. Tilting it back (positive angle) causes the back of the boat to run looser. You don't want to overdo it so just work within the amount of movement provided by the bolts. Also the more you tilt the rudder back the less aggressive the steering becomes.

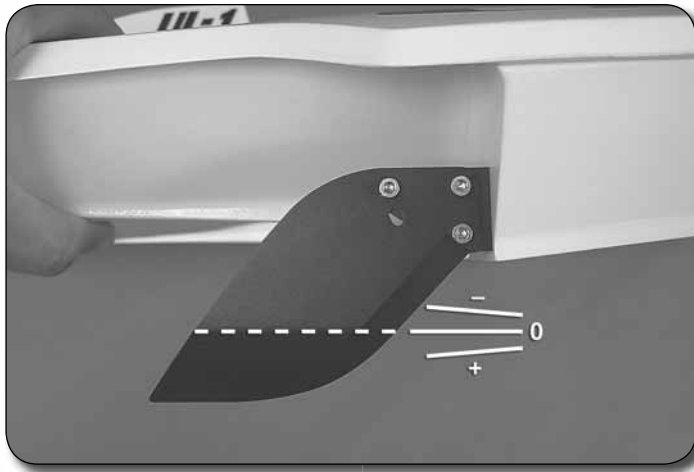

**TURN FIN** – The turn fin is what holds the boat in the corners at speed. The turn fin can also be tilted back and forth to change the way the boat handles. Tilting the fin up (positive) causes the boat to run tighter on the water and tilting it down (negative) causes it to run looser.

**FIBERGLASS** – Like the other parts of the boat you can gain some performance by working the bottom of the boat. You can flat sand the sponson bottoms dead flat to gain more speed as well as roughen the surface to release any surface tension the smooth paint causes. We like to flat sand the bottom of the sponsons and then scuff them with a red scratch pad. The scratched surface keeps the water from clinging to the smooth, painted surface, allowing more boat speed. It's a great tuning secret.

**PROPELLER** – The propeller is the most important part of your boat. It is responsible for the thrust, traction, acceleration, speed and handling of your UL-1. Your UL-1 Superior can use both low and high lifting propellers as well as others. When you are testing your boat, you are going to want to use a prop that allows you the longest runtime and best speed. This propeller might or might not be the one you use when you are racing. Remember a Fast Electric RC boat race only takes a few minutes so the prop you might use for racing could be too hard on your electric components for general operation. During normal operation you are likely to run the boat much longer so be careful not to over prop your boat. To check to see if a prop is too much load for your electronics run the boat for one minute. Bring it in and check the temperatures of both the ESC and the motor. If they are hot or you cannot hold your finger on either part for more than 5 seconds, you are over propped.

#### **AQUACRAFT GRIMRACER PERFORMANCE PROPS FOR THE UL-1 SUPERIOR**

- AQUB9720 40x52/3 Metal Prop (3-Blade)
- AQUB9755 L38x55 Metal Prop
- AQUB9760 L40x57/3 Metal Prop (3-Blade)



## **RACING**



#### **GET ON THE CLOCK AND MILLING ON THE COURSE:**

Getting on the clock is a term we use to get our boats ready for the start of the race. In RC boat racing we use rolling starts and part of the fun is milling the boat, or the time we spend getting on the clock. Timing is everything and your boat has to be dependable enough to mill well and go fast enough to win the race.

The start of an FE RC boat race is typically broken down into three sections. Total clock time is 60 seconds and broken down into the following: Preparation time, 60 to 30 seconds. This is what we call "get ready" time and lasts for 30 seconds. Next is launch time, 30 to 11 seconds. This is the time when boats are launched and must be up and running. Last is "No Launch" time, 10 to 0 seconds. Boat cannot be launched after this time. This is also the point where the boats are milling, picking lanes and ready for the start.

#### **DRIVING A LANE:**

In RC boat racing our boats race around an oval course. A lane is the distance outside the buoys that is approximately the width of our boat. If there is a boat around yours, you have to hold your lane as you are driving next to it. If you are clear of any other boats, you can choose to run your boat in any lane you like. Depending on the boat setup some boats run faster on an inner or outer lane.

#### **PASSING:**

Passing another boat properly takes preparation and power. If you are in an outside lane and the boat you want to overtake is to your inside, you're going to have to give that boat some room before overtaking the lane. Make sure you have AT LEAST 3 boat lengths before overtaking that boat's lane. Truth is it's best to have doubled that distance to avoid drawing an infraction. It is best to stay with the lead boat and hunt out his or her weaknesses on the racecourse. If they have a habit of going wide off buoy 6, take note. If you get the chance, sneak in behind them and try to overtake them on the inside. Remember, if you race your opponent cleanly, they will likely return the favor as you are now inside their boat.



## NATIONAL ORGANIZATIONS:

The below organizations have rules for racing model boats like your UL-1 Superior.

**International Model Power Boat Association (IMPBA)**  
[www.impba.net](http://www.impba.net)

**North American Model Boat Association (NAMBA)**  
[www.namba.com](http://www.namba.com)

## ORDERING REPLACEMENT PARTS

To order replacement parts for the AquaCraft UL-1 Superior use the order numbers in the replacement parts list that follows. Replacement parts can be purchased from your local hobby shop or by mail order. If you need assistance locating a dealer to purchase parts, visit [www.hobbico.com](http://www.hobbico.com) and click on "Where to buy". If you are missing parts, contact Hobbico Product Support at:

Phone: 217-398-8970

Fax: 217-398-7721

E-mail: [productsupport@hobbico.com](mailto:productsupport@hobbico.com)

AQUB6227 .... Nose Canopy  
AQUB6999 .... Hatch  
AQUB6431 .... Exhaust Headers L&R  
AQUB9300 .... Vertical Fins Yellow  
AQUB9301 .... Vertical Fins Orange  
AQUB9302 .... Vertical Fins Red  
AQUB9303 .... Vertical Fins White  
AQUB8650 .... Rearview Mirrors  
AQUB7869 .... Teflon .150" Cable Liner 10"  
AQUB7106 .... Boat Stand  
AQUB6302 .... Decals  
AQUB8729 .... Rudder Tiller Arm  
AQUB7873 .... Flex Drive .150" Cable  
AQUB9539 .... Hydro Turn Fin 2mm CNC Black  
AQUB8730 .... Rudder Mounting Bracket  
AQUB8731 .... Rudder Blade  
AQUB6950 .... Strut Assembly  
AQUB8780 .... Steering Rod Assembly  
AQUB7895 .... Motor Mount  
AQUB7896 .... Motor Screws  
AQUB8781 .... Steering Servo Mount  
AQUB9540 .... Water Cooling Jacket 36mm Dia.  
AQUB9760 .... 40 x 57/3 Lifter prop  
AQUG7001 .... 36-56-2030 6-Pole Marine Motor  
AQUM7011 .... 60-Amp WC/WP LiPo ESC  
TACJ2400 ..... Tactic TTX240 2.4 Transmitter  
TACL2400 ..... TR-324 Tactic 2.4 Receiver

## GRIMRACER™ Precision Prop Balancer

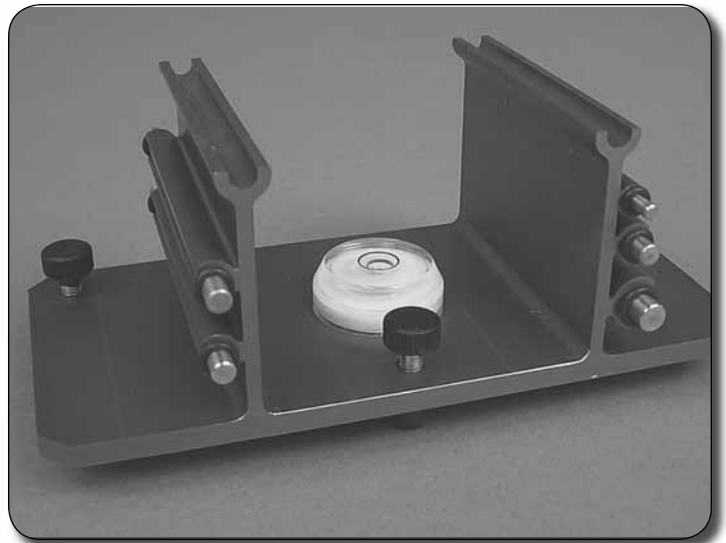

To maximize performance — and minimize damage to on-board electronics and parts — balance your props with the GrimRacer Precision Prop Balancer. It's easy to use. Three thumb screws provide perfect level adjustment, and a precise bubble level is built into the one-piece extruded aluminum base. The balancer includes balancing shafts for 1/8" (3.2 mm), 3/16" (4.8 mm) and 1/4" (6.4 mm) bore prop hubs. Propeller not included. **AQUB9575**



### GrimRacer™ Pro Radio Box Tape

Like champion racer Michael "Grimracer" Zaborowski, use this 3/4" wide, clear electrical 3M tape to seal your boat's radio box water-tight. **AQUB9514**



# V51™

*Assemble a competition-class wood tunnel hull in just 6-8 hours!*



**Hull Length:** 28 in (711 mm)

**Beam:** 11 in (280 mm)

**Height:** 5.25 in (130 mm)

**Ready-to-Run Weight:** 4 lb (1814 g)

**Requires:** 2+ channel radio with one high-torque standard servo and one mini servo, .21 cu in (3.5 cc) outboard engine

The kit form of this Mike "Grimracer" Zaborowski design took the first of its 10 titles at the 2000 IMPBA Internats. Now, you can enjoy the same title-taking performance (and top-drawer construction features) in an ARR. The built-up wood sponsons and wood-over-foam center hull section are both warp-resistant, and finished in a high-gloss clearcoat. GrimRacer performance hardware (from stainless steel pull-pull cables to the cowl thumbscrews) is evident throughout, and the fuel tank (which holds 8 fl. oz.) was "Grim" designed specifically for .21 tunnel hulls. Wanna make racing against you a "grim" prospect for your competitors? Then get yours now! **AQUB0006**



### **GrimRacer™ Speed Grease™ Cable Lube**

This waterproof blue lubricant — with specially formulated, "non sling" properties — reduces friction and wear on the cable and direct drive systems in electric and nitro boats. **AQUB9500**

# AQUACRAFT

Models



*Take a romp through the swamp!*



**Length:** 30 in (770 mm)

**Beam:** 11.25 in (285 mm)

**Height:** 14 in (355 mm)

**Weight:** 6 lb 5 oz (2.86 kg)

**Includes:** SuperTigre® G34 engine w/exhaust, Tactic™  
2-channel 27MHz radio

**Requires:** 10-15% nitro aircraft glow fuel, glow igniter, fuel  
bottle, electric starter, 12V battery, 12 "AA" batteries

When you see an airboat, isn't your first thought "Wow! Wouldn't that be a blast to drive?" Well, now's your (complete, ready-to-run and easy to operate) chance to find out. Living by a pond or lake isn't required; you can run it on ice, snow or even wet grass. Molded-in strakes on the painted fiberglass hull keep you in control, even at high speeds. Power comes from a SuperTigre® G-34 airplane engine and an APC™ 9x6 pusher prop, which are safely enclosed in a realistic welded steel cage. Huge fiberglass air rudders give you the power for both subtle course corrections and wide, sweeping skid turns. A 2-channel Tactic™ radio for control rounds out a package that also includes a set up DVD, detailed driver and passenger seats and a display/carrying stand. **AQUB29\*\***

# AQUACRAFT

Models

